



The Professional Lighting

for Photo, Video, Cine & Theatrical

SourceBook

Section 1

Introduction to Lighting

Whether you are lighting a stage or set, shooting still or video, using film, tape or solid-state media, proper lighting is essential to produce professional results. We are able to see because light reflects off the subject we look at. Regardless of the type of camera you shoot with, without light, your subject will not be recorded. Color, contrast, shape, and texture are just some of the attributes that are revealed through the effective use of light.

When you first consider purchasing lights, the choices can be overwhelming. The Lighting SourceBook is here to help you. This introduction will give you a basic understanding of lighting fundamentals that will enable you to make intelligent choices. The B&H Lighting SourceBook is divided into sections categorized by lighting fixture type. Each fixture type will be explained in detail at the beginning of its section.

INTRODUCTION TO LIGHTING

What Is Light?

Essentially, light is made up of wave-particles called photons. Visible light falls in the Electromagnetic Spectrum, between approximately 400 and 700 nanometers (1 nanometer=one billionth of a meter). White light consists of all visible colors combined. The color of visible light changes in respect to its wavelength. Red, being the longest wavelength and violet, the shortest. A rainbow or light passing through a prism demonstrates white light being separated into its component colors.

The Electromagnetic Spectrum

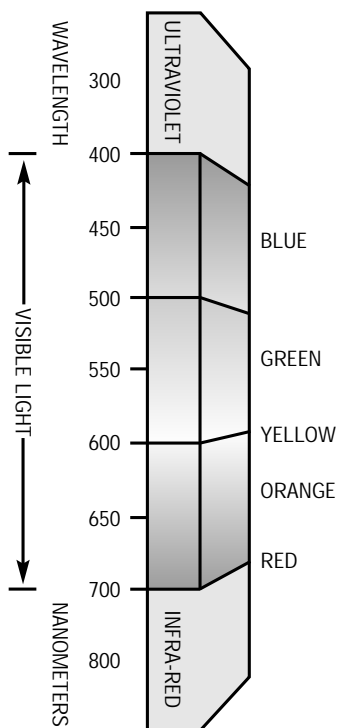

Light Measurement

There are many ways to measure the quantity and quality of light. Of course, a unit of measure is essential. Don't be

intimidated by the technical jargon. Unless you're a physicist, odds are you will not be familiar with all terms listed, nor do you have to be. A good light meter will provide you with all the information you need. You may see light specifications described in one of the following terms:

Candela

The candela (abbreviation, cd) is the standard unit of luminous intensity in the International System of Units. Originally, luminous intensity was measured in terms of units called candles. This was based on the approximate amount of light emitted by a candle flame. Late in the 20th century, the current definition and terminology was adopted to allow for consistent and repeatable measurements of light. The term candela also refers to candle power, 1 candela = 1 candlepower.

Candela is formally defined as the magnitude of an electromagnetic field, in a specified direction, that has a power level of 1/683 watt (1.46×10^{-3} W) per steradian at a frequency of 540 terahertz (540 THz or 5.40×10^{14} Hz).

Foot-candle

The Foot-candle is the measurement of light output in candela per square foot. The Foot-candle is used frequently to quantify the amount of light present in a given area. In the B&H SourceBook, many of the lights will list the photometric data next to the light. The unit the light is measured by is in foot-candles. The photometric data will enable you to compare the performance of

the products you may be interested in.

The Foot-candle is a standard reference unit used to measure the illuminance on a surface that is everywhere one foot from a uniform point source of light of one candle and equal to one lumen per square foot.

Foot Lambert

The Foot Lambert is a unit of luminance equal to the luminance of a perfectly diffusing surface that emits or reflects one lumen per square foot.

Lux

Lux is a unit of illumination equal to the direct illumination on a surface that is everywhere one meter from a uniform point source of one candle intensity or equal to one lumen per square meter.

Lux is a term commonly used to show the minimum amount of light needed for a video camera to function. Many video cameras are so sensitive, that they require small amounts of light to function properly, and are referred to as "low Lux cameras".

One lux is the equivalent of 1.46 milliwatt (1.46×10^{-3} W) of radiant electromagnetic (EM) power at a frequency of 540 terahertz (540THz or 5.40×10^{14} Hz), impinging at a right angle on a surface whose area is one square meter. A frequency of 540 THz corresponds to a wavelength of about 555 nanometers (nm), which is in the middle of the visible-light spectrum.

Lumen

A unit of luminous flux equal to the light emitted in a unit solid angle by a uniform point source of one candle intensity.

NOTE: The most commonly

used terms used in lighting are the foot-candle, and lux.

Watt Second

This standard is used to measure the total power potential of electronic flash power packs. One watt second is a measurement of stored energy equal to one joule per second.

Many factors affect the actual light reaching the subject and must therefore be considered. The flash systems power pack simply stores the energy in capacitors that, when triggered, release this energy through the flash tube. Different flashes of similar energy storage capacity will produce different amounts and qualities of light.

Choosing equipment solely on its watt second rating will not give a true representation of its light producing capability. The quality and optimization of the design of the flash tube and reflectors contribute significantly to a system's overall performance.

It is impossible to accurately assess the quantity and quality of a system until the stored energy in its capacitors are converted to usable light in the flash tube and focused by the reflector on the subject. The narrower the angle and the more polished the reflector, the more light will be directed toward the subject.

When comparing products you must take into account variations in manufacturers specs. Reflector angle, reflector finish, flash tube color temperature, flash to subject distance, ISO etc., must all be equal before comparing specs.

Guide Number

Electronic flash units with fixed reflectors are usually rated with a guide number for a specific ISO (usually ISO 100). The guide number is used to calculate the lens f/stop setting for a good flash exposure when both the ISO rating of the film and the distance from the flash to the subject are known.

To determine the f/stop needed, divide the **guide number** by the distance. To determine the distance that can be illuminated, divide the **guide number** by the f/stop.

When working with guide numbers, be sure to use the same units of measurement in your calculations (meters or feet) as specified by the guide number.

Inverse Square Law

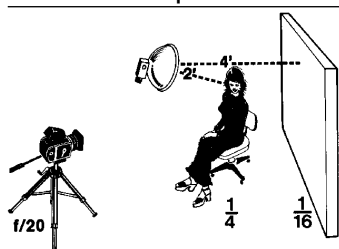

2 f/stops less illumination on background than on subject

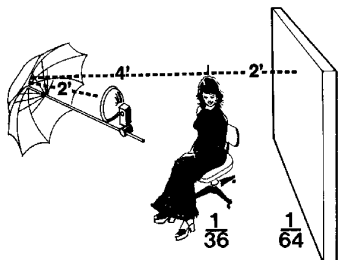

6' from light to subject
8' from light to background
less than 1 f/stop

Illustrations courtesy of Norman Enterprises, Inc.

Inverse Square Law

This is an important law that governs light intensity as a function of distance. The law states that the quantity of light is inversely proportional to the square of its distance.

Examples: A light is placed 1 foot away from the subject. If the distance is doubled to two feet, the square of its distance is (2²) or 2x2=4. The inverse of 4 is 1/4. Therefore, the quantity of light at 2 feet from the subject is 1/4 the amount of light at 1 foot. If the light is moved to a distance of 8 feet, the square of its distance is (8²) or 8x8=64. The inverse of 64 is 1/64. The quantity of light at 8 feet from the subject is 1/64 the amount of light.

Factors Effecting Exposure

Shutter Speed

A camera's shutter speed setting determines the time period light is allowed to strike the film or image sensor. The shutter speed number is calibrated in fractions of a second. The larger the number, the shorter the exposure. 1 equals 1 second, 2 is 1/2 second, 4 is 1/4 second and so on. Each increment represents half the exposure time of the previous setting.

Higher shutter speeds stop movement, whereas slower shutter speeds will cause a blurring effect when shooting fast moving subjects.

F-stop

F-stops, also known as apertures, or lens openings control the amount of light passing through a lens at any

Aperture Setting

↑	F1
↑	F1.4
↑	F2
↑	F2.8
↑	F4
↑	F5.6
↑	F8
↑	F11
↑	F16
↑	F22
↑	F32
↑	F45
↑	F64
↑	F90
↑	F128

MORE LIGHT

LESS LIGHT

Shutter Setting

↑	1
↑	2
↑	4
↑	8
↑	16
↑	30
↑	60
↑	125
↑	250
↑	500
↑	1000
↑	2000
↑	4000

MORE LIGHT

LESS LIGHT

given time. They are expressed as a specific size of an opening in the diaphragm (iris) of a lens in proportion to its focal length. F-stops exist in still, film, digital, and video cameras.

The higher the F number, the smaller the opening. Each consecutive higher number lets in half the amount of light of the preceding number. The lower the number, the larger the opening. Each consecutive lower number lets in twice the amount of light of the preceding number.

The lens aperture also controls depth of field. Depth of field is the distance range that appears to be in focus in front of and behind the film plane. As the aperture increases, (smaller F number), the depth of field decreases. This would be ideal if you want the subject in focus and the rest of the elements in the photo-

graph out of focus so that the viewer's eyes are immediately drawn to it. As the aperture decreases, (higher F number), the depth of field increases, giving you the ability to control the range of foreground and background focus.

ISO

ISO is an international standard to indicate the relative sensitivity of film to light, also called film speed. Film speed is expressed as an ISO number or an exposure index (EI). ISO ratings have replaced earlier ASA and DIN standards.

The higher the ISO number, the more sensitive or faster the film. The lower the ISO number, the less sensitive or slower the film. Film with a relatively high ISO rating requires less light for proper exposure than a lower ISO rated film.

Example: film with a speed of ISO 100 is slower than a film with a speed of ISO 200 and requires twice as much light to record the same exposure.

Many cameras automatically set the film speed by reading a code on the film cassette. Film speed must be set on exposure meters to obtain the correct exposure readings.

The ISO prefix and the older ASA speeds are numerically the same. For example, if the speed of a film were ISO (ASA) 200, you would set 200 on the ISO (ASA) dial of your camera or meter.

Exposure Meters

A good meter is essential in order to arrive at and maintain consistent exposure. Even if you choose to shoot with

available light, a meter will help in controlling the detail and contrast of your images. Your exposure will be accurate, and you will save time in post-production. A bonus is consistency that adds professionalism to your work that will surely be noticed by your clients. An other advantage of using a hand held meter is the ability to achieve repeatable effects when you wish. You can choose your depth of field, lighting ratio and produce high quality results every time you record an image.

Incident Light Versus Reflected Light

Light radiates from its source, whether it is the sun or an artificial source, such as an incandescent light. Light reflects off the subject and enters our eyes so that we are able to see it. The reason we see black as black and white as white is that white surfaces reflect all the visible spectrum, whereas black surfaces absorb most of the light making it appear dark to our eyes.

Incident light is light that travels from the source to the subject and is measured before reflecting off the subject. Light reflected off the subject is called reflected light.

Most camera metering systems measure reflected light. The camera measures the light after it has already reflected off the subject. Spot meters are used at the camera position to measure small areas of light reflected off the subject.

Most handheld meters feature both incident and reflected light measurement. The

advantage of an incident meter is the fact that it measures the quantity of light from the source, regardless of the tonal range of the subject.

Incident Measurement

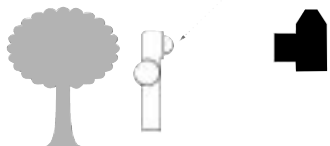

Incident Reading

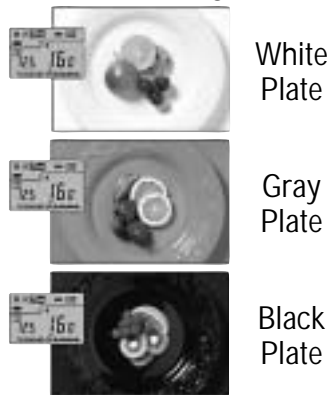

Illustrations courtesy of Mamiya America Corp. Sekonic Professional Division.

Example:
Two subjects a man in a white suit, and a man in a black suit are sitting next to one another on a park bench. It's a bright sunny day, not a cloud in the sky. The same amount of sunlight is illuminating both subjects equally; therefore the exposure should be the same for both subjects.

The reflective metering system in most cameras tries to average the exposure to an 18% (medium) gray. If you were to fill the camera frame entirely with the man wearing the black suit, the camera's meter will try to lighten the exposure, in order to arrive at the

18% gray value. On the other hand, if you were to fill the camera frame entirely with the man wearing the white suit, the camera's meter will try to darken the exposure, to once again arrive at the 18% (medium) gray value.

Even when the light source is the same, the different reflective values of blacks and whites, will cause the exposure to vary substantially with a reflective metering system, resulting in inaccurate readings.

Reflected Measurement

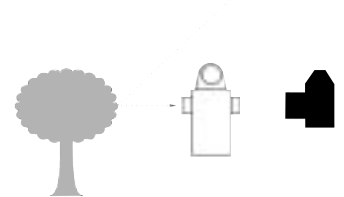

Reflected Reading

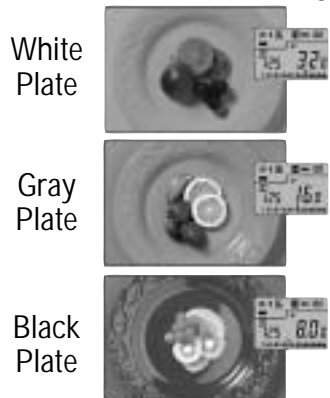

Illustrations courtesy of Mamiya America Corp. Sekonic Professional Division.

With an incident light meter, the light source has not changed so the exposure will be exactly the same for the man in white and the man in black. The tonal values in the blacks and whites will be reproduced accurately.

If you are working with a handheld spot meter, you would have a very precise angle of light measurement as small as one degree. This gives you greater accuracy in choosing the specific tone the light reflects off, to arrive at your exposure.

Gray Card

An 18% gray card is used when you want to achieve proper exposure without having an incident meter. Since the camera's meter is trying to arrive at an average 18% in the first place, if you fill your camera frame with the gray card in front of your subject, the camera's meter will give you the proper exposure for this card, thereby producing an average exposure that should be quite accurate.

Light Fixture Types (Luminaires)

There are many different lighting fixtures that change the quality of the light that is generated by the lamp inside. In the B&H SourceBook, you will see a majority of the different popular types used today. We have defined a few of them for you so you'll get a good idea of what each of them does.

In addition to the sun, light can be created many different ways.

Lamps

Incandescent Lamps

An incandescent light bulb works by heating a solid filament so intensely that the filament's thermal radiation includes large amounts of visible light.

INTRODUCTION TO LIGHTING

LIGHTING

Fluorescent Lamps

A fluorescent tube contains mercury vapor that is ionized by an electrical current flowing through the tube, which is then transformed into visible light by striking fluorescent phosphors that coat the inner surface of the tube.

Gas Discharge Lamps

A gas discharge lamp is a lamp often filled with high-pressure mercury, sodium vapor, xenon or even neon that is excited by an electrical charge to produce visible light with specific color characteristics.

The typical electronic flash tube is constructed from glass or quartz and comes in a variety of shapes. The tube is filled with the inert gas xenon. Electrodes are attached to each end of the tube. Applying a high voltage pulse to the "trigger" electrode on the tubes surface, ionizes the xenon gas in the flash tube. This makes it conductive and permits the tube to discharge the stored energy held in capacitors in a fraction of second, producing a powerful burst of light.

Fixtures

Fresnel

Fresnels are identifiable by the glass lens with the concentric circles on the front of the fixture.

Fresnels are true focusing lights due to the fact that the lamp and reflector move in unison. Fresnel

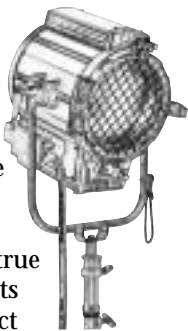

lights provide an even beam with good shadow definition. Fresnels are some of the most popular lights used in film and television production around the globe

Open Face

A general term for a luminaire that does not use a lens. They sometimes may be provided with a safety glass or a wire mesh. Generally they cast a fairly wide beam. They are excellent lights if you are going to diffuse them through a silk, softbox, or bounce them off a reflective panel. They tend to be a little lighter in weight and less expensive than Fresnels.

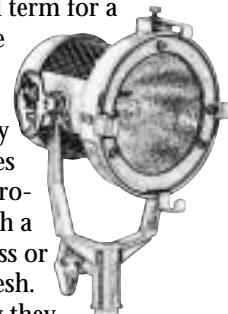

Par

A generally lightweight luminaire that uses a PAR (Parabolic Aluminized Reflector) lamp. The light beam characteristics depend upon the type of lamp used. These types of luminaires are used frequently in stage and theatre productions.

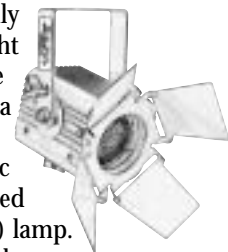

Broadlight

A wide-angle floodlight. Used to direct a large amount of light at a relatively large area.



Softlight

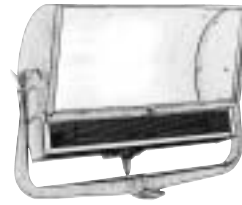

A softlight is an indirect lighting source in which the light bounces off an internal reflector to produce soft light with soft shadow edges.

Ellipsoidal

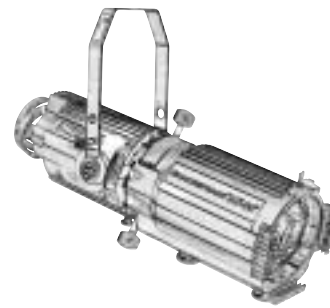

These fixtures are usually classified as spotlights. They usually throw a controlled narrow beam with a sharp edge with strong shadow definition.

Cyc light



A fixture designed to provide an even wash of light on cycloramas (a curved curtain or wall used as a background of a stage set to suggest unlimited space) and backdrops. The cyc light can also be used as a multi-purpose flood or fill light for stage and studio lighting applications.

Controlling Light

After covering the quantity of light and where it comes from, we need to discuss how we are going to change the quality of light in order to achieve optimum results.

Light coming from a point source will be very specular (undiffused - hard shadows) in nature. There are different ways to diffuse (make light softer - soften shadows) light to make it softer.

A rule regarding the quality of light is: the larger the light source and the closer it is to the subject, the softer the light will be. Bouncing light off an umbrella for example, makes the light source change from the size of the bulb to the size of the umbrella, making it bigger and diffusing the light. Similar effects are achieved by bouncing light off a wall or other large surface.

You can also pass light through a diffusion gel, a large diffusion panel, or a softbox. In each case the light source is now the size of that modifier, in turn making it larger. The modifier scatters the light so that it comes from all directions filling in all the surface angles of the subject thereby reducing the contrast significantly.

Light Modifiers

There are many ways to modify the light reaching the subject. They include umbrellas, reflectors, light banks, soft boxes, filters, diffusers, grids, baffles etc. Creative lighting has almost no limits, thanks to

INTRODUCTION TO LIGHTING

the diversity of products available. The appropriate section of the B&H SourceBook will go into greater detail describing the full range of light modifying tools to help you achieve just about any lighting effect you desire.

Light and Color

We use a term called "Light Balancing" to describe how warm or cool the light is (usually referred to in degrees Kelvin). The other term is "Color Correction" which deals more with pure color. In order to achieve accurate color results, you must have the light balanced and color corrected.

Light Balancing

Color temperature is measured in degrees Kelvin. The color temperature of light is measured by taking a black body radiator (an object or system which absorbs all incident radiation upon it and re-radiates that energy back out). When the black body radiator is heated to a certain temperature, it starts to glow orange. As more heat is applied, the temperature increases, getting bluer (less orange), more towards white light and eventually when the black body radiator gets to the upper heat levels, it becomes even more blue, until it won't change anymore. This color is then compared to various light sources, and assigned the temperature of the black body radiator when heated to that color. The following list displays some common light sources with their average color temperatures.

The chart illustrates, when the Kelvin temperature increases, light becomes cooler, bluer. Conversely, as Kelvin temperature decreases, light becomes warmer, more orange. This explains why, daylight film (balanced at 5500k) that is exposed indoors with an incandescent light source (3000k), will produce photographs that appear orange.

Kelvin Temperatures for Common Light Sources

Source	Degrees (in °K)
Clear blue sky	10,000-15,000
Overcast sky	6000-8000
Sunlight, noon	
high altitude	6500
Sunlight average	5400-6000
Electronic flash	5400-5600
On-camera flash	5400-6000
Daylight blue	
flood lamps	4800
Studio photo floods	3400
Studio tungsten bulbs	3200 or 3400
Studio quartz bulbs	3200 or 3400
Household lighting	2500-3000
200w bulb	2980
100w bulb	2900
75w bulb	2820
60w bulb	2800
40w bulb	2650
Single candle	1200-1500

To balance the light for this situation, we can either put a blue gel on the light to remove the orange, or attach a blue filter to the camera lens.

In summary, light balancing deals with the warm or cool aspect of the light (color temperature). With this knowledge an overcast day can be made to look sunny or a sunset can be made to look like midday, simply by choosing the appropriate color filter.

See the chart of Light Balancing filters and their shift in degrees Kelvin.

Warming Filters

For The Camera	Shift (°Kelvin)
85	5500k - 3200k
85 C	5500k - 3800k
81 C/D	5500k - 4500k
81 A/B	5500k - 4900k

Cooling Filters

For The Camera	Shift (°Kelvin)
80 A	3200k - 5500k
80 C/D	3200k - 4100k
82 A/B	3200k - 3500k

The advantage of digital image creation, video or still, is that you are able to white balance or correct the color temperature electronically.

Color Correction

If you have ever taken a picture of someone with daylight film in a room lit by fluorescent lights, you will have noticed that your photos have a green cast to them. Light-balancing filters will only make this color cast warmer or cooler. The only way to eliminate a color cast is to use the opposite or complimentary color of that cast to neutralize it. In this case, a magenta (the opposite of green) filter of the same intensity of the green shift is used to cancel the green effect.

Additive and Subtractive Primary Colors

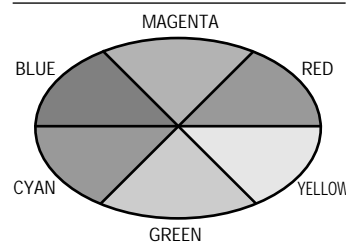

The color wheel illustrates how complimentary colors work. Note on each side of the color wheel is the opposite or complimentary color. For instance if the light source is green, add magenta filtration to correct it. If blue, add yellow to correct it. And if red, add cyan to correct it.

The easiest and most accurate way to determine which filter to use to correct your color balance is to use a color meter.

Digital image capture facilitates color correction through the use of image editing computer software. Naturally, starting with the right color balance, saves time.

Lighting Placement and Definitions

Key Light

The principal or main light source that defines the overall look and the mood of the subject

Fill Light

If you place a light source at a 45-degree angle from the camera position and slightly above the subject, you will create a shadow on the other side of the subject. The function of the fill light is to reduce this shadow creating a flatter more balanced exposure on both sides of the subject.

Background Light

These lights are directed at the background to add a sense of separation between the subject and background.

INTRODUCTION TO LIGHTING

Back Light (Separator Light)

Back lights are directed towards the subject from behind, adding separation between the subject and background. These lights tend to give a fringe of light that surrounds the subject. Back lights are also used to highlight a subject's hair.

Rim Light

This light is usually used for lighting objects instead of people.

Kicker

The kicker is used to light the side of a subject usually from a low angle located behind and towards the side of the subject.

Three Point Lighting

The traditional starting point to light a subject is three-point lighting. Basically, one light is located at 45 degrees to the camera, this is the main or key light. The fill light is positioned 45 degrees to the camera on the other side, and the backlight is placed on a boom just slightly behind and above the subject's head.

The diagram illustrates the basic positioning of three-point lighting.

Three-point lighting is only the starting point, but by no means must you light your subjects in this manner. It is always good to start with a proven method to get the feel of things. Once you feel comfortable with the results you are getting, you can become more creative with your lighting set ups. The beautiful thing about lighting is that you can see your results as you set up your lights.

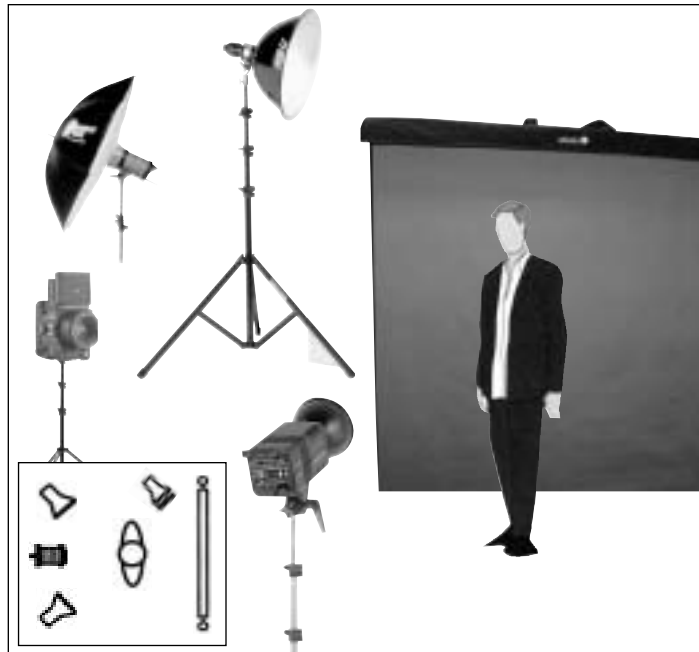

Most strobes also include modeling lights to provide a preview of your lighting effects. The main thing to concentrate on is exposure and controlling the lighting ratio of the different luminaires.

Lighting Ratios

Ratios are commonly used to express the difference between the amounts of light on one side of the subject and the other. This ratio is usually expressed in numerical form starting with the key light in proportion to the fill light.

For example:

If a ratio is 1:1, it means that the fill light is the same intensity as the main light.

RATIO TABLE - F-STOPS

KEY	FILL	RATIO
F11	F11	1:1
F11	F8	2:1
F11	F5.6	4:1
F11	F4	8:1
F11	F2.8	16:1
F11	F2	32:1

This type of lighting will produce a very flat light that is very clean without much drama. If the ratio is 2:1, the key light will give you twice the amount of light as the fill, creating a slight shadow on the fill side of the subject. This is one of the most commonly used ratios.

When in doubt, start with a 2:1 ratio to see how it looks on your subject. If the ratio were 4:1 you would have a main light with four times the amount of light as the fill, creating a greater shadow on the fill side of the subject.

As you increase the ratio between your key and fill lights, you will be adding more shape, and produce more dramatic results.

Caution

Before you continue to the rest of the B&H SourceBook, there are a few points about safety that need to be addressed.

Bulbs should never be touched by bare skin. Grease from skin can cause the glass to weaken. This weakening may lead to shortened lamp life and/or explosion. Bulbs should be handled with paper, plastic, or cloth to avoid contact with skin.

Almost all light fixtures provide some kind of protective screen or glass to cover the front part of the fixture. It is rare for lamps to explode. However, in the instance that one does, there will be red-hot shards of glass flying through the air after what sounds like a gunshot. The safety features are there for your protection. It is well advised that you use them.

Whenever a fixture is mounted from above, a safety cable is an inexpensive way to insure safety. If the light were to come loose from its mount, the safety cable will support the weight of the fixture, preventing injury until the problem can be fixed.

When lighting is used in public places, seek advice from a qualified gaffer or other lighting professional. This is a great way to make sure all local electrical and safety codes are complied with.

Conclusion

As you continue through the B&H SourceBook, you will find more in depth information to help you become a lighting expert. Each section is packed with helpful guides and lighting instruction, so make sure you review the B&H SourceBook from cover to cover.