





The **PROSUMER** Video

SourceBook

Section 2

Camcorder Accessories

LCD Monitors and Accessories.....	122
Power and Lighting.....	123-127
Camcorder Filters.....	128-129
Camcorder Lenses	130-141
Camcorder Support.....	142-157
Audio for Video	158-178
Camcorder Bags	179-185
Underwater Housings	186-195

VARIZOOM

VZ-TFT SERIES

ACCESSORIES

122

Active Matrix LCD Video Monitors

VariZoom's VZ-TFT series monitors serve two purposes. First, they function as an external video display, allowing you to step back from the camera while recording (no more bending over to peek through a tiny viewfinder). Second, combined with a tripod-mounted camera and a VariZoom lens controller, they can emulate a studio-style rig costing thousands of dollars. Used on a hand-held camera, a VZ-TFT monitor lets you walk around with ease while accurately framing shots. Additionally, it is a highly compact and affordable alternative to bringing a conventional CRT video monitor into the field for video playback. Use them to review footage on an airplane or any other small space. Mounted on or near the camera, they provide instant playback of footage for small groups. For those who want audio monitoring and playback, the VZ-TFT-4 has a built-in speaker.



- ◆ Large, bright active matrix display has wide viewing angle
- ◆ TFT Technology means no blurring/strobing of the video image as commonly found on conventional Dual-Scan displays
- ◆ Controls to adjust color, and brightness
- ◆ Optional swivel-mount threads into monitor's bottom side, attaches to camera accessory shoe position at any angle
- ◆ Clean body style on all four sides of the VZ-TFT allows use of the optional VZ-HD-56 sun hood.

VZ-TFT SERIES PRICING

VZ-TFT-4 4" TFT Monitor with A/V cables and power supply	199.95
VZ-TFT-CB4 Same as above plus case, straps and VZ-702M Li-ion battery kit	274.95
VZ-TFT-4 4" TFT 'PAL' Monitor with A/V cables and power supply.....	209.95
VZ-TFT-CB4P Same as above plus case, straps and VZ-702M Li-ion battery kit ..	284.95
VZ-TFT 5.6" TFT Monitor (NTSC/PAL with video cable and power supply)	274.95
VZ-TFT-CB Same as above plus case, straps and VZ-702M Li-ion battery kit.....	329.95
VZ-TFT- Same as above plus swivel shoe camera mount and VZ-HD-56 hoodt	349.95

EXTENDED PROTECTION PLAN

COVERS ALL PARTS AND LABOR PAST MANUFACTURER'S WARRANTY

B&H Photo-Video offers the Mack warranty – an extension of the manufacturer's normal warranty on the equipment for an additional period of up to four years. Your video equipment will be guaranteed to operate properly according to manufacturer's specifications or it will be repaired at no charge to you (this includes parts and labor and head replacement when necessary).

DV Camcorders

2 Year Extended Warranty

for camcorders valued to \$999.99	\$44.95
for camcorders valued \$1000.00 to \$1499.99	\$69.95
for camcorders valued \$1500.00 to \$1999.99	\$84.95
for camcorders valued \$2000.00 to \$3499.99	\$99.95
for camcorders valued \$3500.00 to \$4999.99	\$129.95
for camcorders valued \$5000.00 to \$8000.00	\$189.95

4 Year Extended Warranty

for camcorders valued to \$999.99	\$59.95
for camcorders valued \$1000.00 to \$1499.99	\$99.95
for camcorders valued \$1500.00 to \$1999.99	\$124.95
for camcorders valued \$2000.00 to \$3499.99	\$149.95
for camcorders valued \$3500.00 to \$4999.99	\$169.95

Dropped, misused, water, sand, or impact damaged equipment not covered.



ONE HOUR FREE PARKING
AT 349 W. 34th STREET (with purchase of \$100 or more)

POWER 2000

LITHIUM-ION BATTERIES

i-CUFF Camera Eyecup

Made from water-proof, breathable, washable, and lightweight high-tech fabric, the i-Cuff fits almost all camcorders. Its Velcro tightening strap enables individualized positioning and personalized fit.



- ◆ Contoured wrap-around design
 - ◆ Ultrasuede HP chamois offers the ultimate in comfort—especially during long shoots.
 - ◆ Works fabulously with or without glasses
 - ◆ Superior light-blocking
 - ◆ Fits most pro/semi-pro video/film cameras
- i-Cuff DV:** for viewfinders smaller than the Canon XL-1s**34.95**
- i-Cuff Pro:** for larger viewfinders like the XL-1s and Panasonic DVX100A**49.95**

HOODMAN LCD Hood

Never miss a shot indoors or outdoors because the lighting is too strong. With a Hoodman on your camcorder's LCD you will have glare-free outdoor viewing of all the action. Lightweight and durably constructed, they fit all Sony, JVC, Canon and Panasonic camcorders. Attaches with elastic strap or velcro. Four sizes to fit any camcorder:



- H-180** fits 1.5-1.8" LCD monitors**97.95**
- H-200** fits 2.0- to 2.5" LCD monitors....**14.95**
- H-300** fits 3" LCD monitors.....**17.95**
- H-400** fits 4" LCD monitors.....**19.95**

Power 2000 Batteries and Accessories

Vidpro has a 50-year history of manufacturing superior quality and reliable batteries and accessories for the video industry. Power 2000 batteries are meticulously crafted and assembled using the highest quality components in state-of-the-art facilities. The batteries use only top-grade matched cells and are triple tested under the most stringent standards. This assures you of long-lasting and unsurpassed performance. All Power 2000 Li-ion Batteries have a two-year warranty.

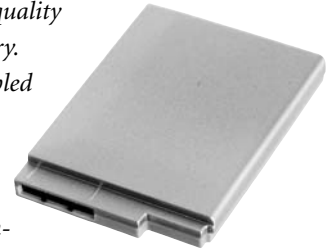

Replacement Lithium-Ion (Li-ion) Batteries for Sony

- | | |
|---|---|
| ACD-601L: Replaces NP-F550L (2000 mAh)..... 39.95 | QP-7400: AC/DC Fast Charger for ACD-600/700 series batteries 34.95 |
| ACD-602L: Replaces NP-F750L (4000 mAh)..... 49.95 | ACD-690: Replaces NP-FF70 (1500 mAh) 69.95 |
| ACD-607L: Replaces NP-F960L (6000 mAh)..... 59.95 | QP-103: AC/DC Fast Charger for ACD-690 39.95 |
| ACD-701: Replaces NP-FM50 (1800 mAh) 34.95 | DAC-SONY: AC Adapter for Sony cameras using NP-F or NP-QM batteries 29.95 |
| ACD-702: Replaces NP-QM71D (3600 mAh) ... 59.95 | |
| ACD-703: Replaces NP-QM91 (5400 mAh) 69.95 | |

Canon Replacement Lithium-Ion (Li-ion) Batteries

- | | |
|---|---|
| ACD-605: Replaces BP-915 (2000 mAh) 29.95 | QP-8200: AC/DC Fast Charger for above 29.95 |
| ACD-606: Replaces BP-930 (4000 mAh)..... 49.95 | ACD-674: Replaces BP-511 (1500 mAh) 34.95 |
| ACD-625: Replaces BP-945 (6000 mAh) 59.95 | ACD-675: Replaces BP-522 (3000 mAh)..... 49.95 |
| | ACD-685: Replaces BP-535 (4500 mAh) 69.95 |
| | QP-7600: AC/DC Fast Charger for above 39.95 |
| | ACD-676: Replaces BP-408 (1000 mAh) 39.95 |
| | ACD-677: Replaces BP-412 (2000 mAh) 39.95 |
| | ACD-678: Replaces BP-422 (3000 mAh) 59.95 |
| | QP-8300: AC/DC Fast Charger for above 29.95 |
| | ACD-693: Replaces BP-2L12 (1500 mAh) 49.95 |
| | QP-9100: AC/DC Fast Charger for ACD-693 .. 39.95 |



Panasonic Replacement Lithium Ion (Li-ion) Batteries

- | | |
|--|--|
| ACD-628: Replaces CGR-D08 (1200 mAh) 34.95 | ACD-697: Replaces CGR-DU07(800 mAh) 39.95 |
| ACD-629: Replaces CGR-D16 (2400 mAh) 39.95 | ACD-695: Replaces CGA-DU14 (1600 mAh) .. 59.95 |
| ACD-682: Replaces CGR-D28 (3000 mAh) 59.95 | ACD-696: Replaces CGA-DU21 (2400 mAh) .. 79.95 |
| QP-8700: AC/DC Fast Charger (for the above batteries)..... 29.95 | QP-107: AC-DC Rapid Charger (for the above batteries)..... 29.95 |

JVC Replacement Lithium Ion (Li-ion) Batteries

- | | |
|---|---|
| ACD-668: Replaces BN-V408U (1200 mAh) .. 34.95 | ACD-684: Replaces BN-V114. (2000 mAh) 59.95 |
| ACD-669: Replaces BN-V416U (2000 mAh) ... 39.95 | ACD-620: Replaces BN-V507U (1200 mAh) ... 39.95 |
| ACD-670: Replaces BN-V428U (3200 mAh) ... 59.95 | ACD-621: Replaces BN-V514 (2400 mAh) 54.95 |
| QP-8600: AC-DC Rapid Charger (for the above batteries)..... 29.95 | QP-8400: AC-DC Rapid Charger (for the above batteries)..... 29.95 |
| ACD-683: Replaces BN-V107 (1000 mAh)..... 49.95 | |

BESCOR

POWER & LIGHTING

ACCESSORIES

124

20 & 40-watt Switchable Light with Compact Battery

A neat little light set up ideal for general purpose lighting. Runs for 35 minutes at 40 watts and 75 minutes at 20 watts on the supplied 6v rechargeable lead acid battery. Battery recharges in 8 hours with BC-665 overnight charger. Two slide switches are located on the light for easy control. Two barn doors and universal shoe mount also included.

KLK-624 light with battery, charger and two 20 watt bulbs69.95

KLK-624D same as above plus adds a diffusion filter to reduce unwanted glare 79.95



PT-104 12-Volt Battery Tester

Digital read out with LED range indicator. Swivel display head. Accurate to within 1/10 volt. Use Y-21 to hook up in-line with your 12v battery14.95

NMH-54 Compact Clip-on 12v NiMH Battery Packs

A memory and maintenance-free NiMH (Nickel Metal Hydride) battery, the NMH-54 uses environmentally-friendly Panasonic cells for consistently long run times over the life of the battery.

The ultimate answer in lightweight comfort, the NMH54 "Sidekick" is also available in a 4-pin XLR version, making it ideal for the MPL-635 and MPL-645 lights.

◆ Size: 3.9 x 3 x 1.7"

◆ Weight: 1.2 lbs.

◆ Capacity: 4.5 amp hours

◆ Charge Time: 14 hours

◆ Run Time:

@ 10w: 5+ hours

@ 50w: 1 hour

@ 100w: 30 minutes

NMH-54139.95

NMH-54XLR149.95



12-VOLT SLIM LINE BATTERIES

SLM-5 12v Slim Line Battery Packs

One of the smallest and most lightweight batteries, it can power a 50 watt light for almost an hour.

Mounts on your waist via a military clip mounted on the backside.

Weight: 3.2 pounds.

Dimensions: 4.7" x 4" x 2".

Capacity: 4.2ah 50 WH

Includes: Automatic Shut-Off Charger

SLM-5ATM with cigarette lighter socket79.95

SLM-5XLRATM with 4-pin XLR connector99.95



SLM-10/18 12v Slim Line Battery Belts

These easy-to-wear batteries are very comfortable, yet supply long lasting power. High rate Panasonic Starved Electrolyte cells, the same used in the 14v series, are used in the SLM series.

Includes the ATM-PRB Automatic Shut-Off Charger. The charger is rated at 1 amp with LED indicator.



SLM-10ATM with cigarette lighter socket159.95

SLM-10XLRATM with 4-pin XLR connector179.95

SLM-18ATM with cigarette lighter socket239.95

SLM-18XLRATM with 4-pin XLR connector249.95

Model	Size	Weight	Capacity	Charge Time	Run Time		
					at 100W	at 50W	at 10W
SLM-5ATM	4.7" x 4" x 2"	3.2 lbs.	4.3 amp hours	5 hours	35 min	50 min	5 hours
SLM-10ATM	2" x 2" x 26"	7.3 lbs.	8.6 amp hours	10 hrs.	1 hour	2 hours	10 hours
SLM-18ATM	4" x 4" x 26"	14 lbs.	17.2 amp hours	19 hours	2 hours	4 hours	25 hours



www.bhphotovideo.com

BESCOR

POWER & LIGHTING

NMH-90

Lightweight 12v NiMH Battery Belt for Lighting and Camera Power



A memory and maintenance-free NiMH (Nickel Metal Hydride) battery belt, the NMH-90 uses environmentally-friendly Panasonic cells for consistently long run times over the life of the battery. The ultimate answer in lightweight comfort, the NMH-90 is both low-profiled and comfortably lightweight. Also available in XLR version with a 4-pin XLR on a 6' multiflex lead as well as cigarette socket (dual output) making it ideal for the MPL-635 and MPL-645 lights. It weighs 4 lbs., powers a 100 w light for 50 minutes, and a 50 w light for 2 hours. It charges in 8 hours.

NMH-90.....259.95 NMH-90XLR269.95

Portable-Series Portable 12v Shoulder Battery Packs

Bescor's Portable 12v Battery Packs are ideal for powering lights, camcorders, phones, computers, power tools or any device that will run from an automobile cigarette lighter. There are five portable shoulder battery packs including: the Half-Pint, the Mainstream, the ECO Pack, and the Excalibur. Each one includes a cigarette lighter output, an overnight charger, and each can be charged up to 1500 times.



	MM-7 Mainstream	MM-9 12v Pack	BES-015 ECO Pack	BES-018 12v Pack
AMPS	7.2	9 amps	14 amps	18 amps
Battery Type	Lead Acid	Lead Acid	Lead Acid	Lead Acid
Weight	5 lbs.	5.8 lbs.	10 lbs.	12 lbs.
Dimensions (W x H x D)	6.5 x 4.5 x 2.5"	7.4 x 6 x 2"	9 x 6.5 x 2.5"	8 x 6 x 2.8"
Run-Time @10w	6 hrs.	9 hrs.	13 hrs.	18 hrs.
Run-Time @50w	1 hr.	1.8 hrs.	2½ hrs.	4 hrs.
Run-Time @100w	1/2 hr.	45 min.	1¼ hrs.	1.8 hrs.
Charge Time	15 hrs.	18 hrs.	15 hrs.	18 hrs.
PRICES:	49.95	64.95	89.95	109.95



PRB-Series Professional 12v Battery Belt

Similar to the 12v Shoulder Packs series (above), Bescor's PRB-series provides premium power for heavy-duty draw applications like lighting. Each belt has a cigarette lighter output and is available with XLR output as well. Each belt also includes an overnight charger and can be charged up to 600 times.

	PRB-7	PRB-9	PRB-12	PRB-15	PRB-154	PRB-20
AMPS	7,200	9amps	12 amps	14,400	14,400	20,000
Weight	5 lbs.	6 lbs.	8.5 lbs.	11 lbs.	11 lbs.	16 lbs.
Dimensions (W x H x D)	4 x 13 x 1.25"	4" x 6" x 2.5"	4.5" x 13" x 2"	4.5 x 13 x 2.5"	4.5 x 26 x 1.25"	4.5 x 26 x 2"
Run-Time @10w	6 hrs.	9 hrs	14 hrs.	13 hrs.	13 hrs.	20 hrs.
Run-Time @50w	1 hr.	1.8 hrs.	2.4 hrs.	2-1/2 hrs.	2-1/2 hrs.	4 hrs.
Run-Time @100w	1/2 hr..	50 min.	1.2 hrs.	1-1/4 hrs.	1-1/4 hrs.	2 hrs.
Charge Time	15 hrs.	11 hrs.	13 hrs.	15 hrs.	15 hrs.	20 hrs.
Price (with XLR, add \$20)	74.95	64.95	89.95	99.95	129.95	149.95

ACCESSORIES

125

BESCOR

MPL-635/MPL-645

ACCESSORIES

126

Luxmen Studio Broadcast DC Lights

The MPL-635 and MPL-645 are contemporary-styled lights that include an intergrated universal shoe mount adapter and improved topside venting. They include a 5600°K dichroic filter for perfect daylight illumination. The hinged filter can be flipped down for normal 3200°K lighting and it also makes bulb replacement a snap. They include a 4-leaf barn door set that is completely adjustable and 6' coiled power cable with 4-pin XLR connector.

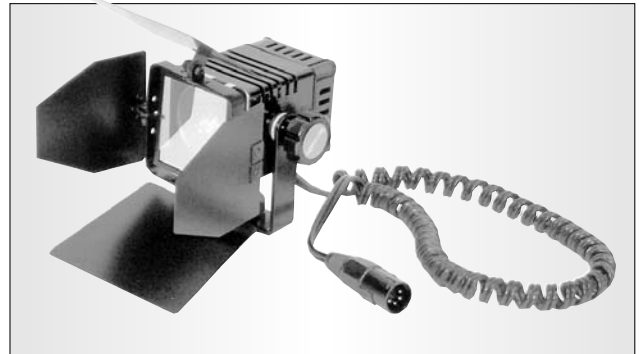

◆ To satisfy most lighting conditions, the MPL-635 includes 2 bulbs, a 100 watt (FCR), and a 50 watt (BRL). An optional 35 watt bulb (JC12V35) is also available.

◆ For even more versatility, the MPL-645 adds a variable control that lets you adjust the light from 0 all the way to 50 watts. This also lets you conserve battery power by lowering your lights wattage requirement. A high pulse circuit helps maintain the bulb's color temperature.

MPL-635 Battery and Light Combo Kits

MK-7 MPL-635 Light and MM-7XLR Battery.....	194.95
MK-12 MPL-635 Light and PRB-12XLR Battery.....	239.95
MK-7ATM MPL-635 Light and MM-7XLRATM Battery	224.95
MK-12ATM MPL-635 Light and PRB-12XLRATM Battery.....	259.95
MK-54 MPL-635 Light and NMH54XLR Battery.....	269.95
MK-10ATM MPL-635 Light and SLM10XLRATM Battery	299.95

MPL-645 Battery and Light Combo Kits

AK-7 MPL-645 Light and MM-7XLR Battery	234.95
AK-12 MPL-645 Light and PRB-12XLR Battery.....	279.95
AK-7ATM MPL-645 Light and MM-7XLRATM Battery	264.95
AK-12ATM MPL-635 Light and PRB-12XLRATM Battery	299.95
AK-54 MPL-635 Light and NMH54XLR Battery.....	309.95
AK-10ATM MPL-635 Light and SLM10XLRATM Battery	359.95

A/C and D/C Lighting with Soft Diffuser

- ◆ Compact precision molded light
- ◆ Twin vertical barn doors
- ◆ Soft Diffuser Filter

- ◆ Universal shoe mount
- ◆ Surface mounted on/off switch
- ◆ 6' coil cord with 120v AC plug

VS-100AC Includes 100 watt A/C bulb.....39.95

VS-100 Includes DC adaptor and 100 watt 12v D/C bulb.....39.95

VS-150AC Includes 150 watt A/C bulb.....42.95

VS-50 Includes DC adaptor and 50 watt 12v D/C bulb39.95

VS-65 Includes 100 watt A/C bulb, 50 watt D/C bulb and adaptor.....49.95

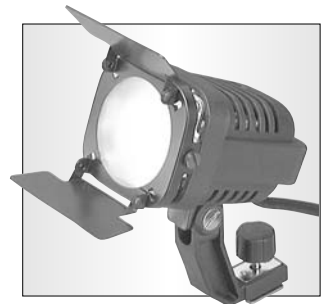

A/C and D/C Commercial Flood Light

- ◆ Front housing snaps off easily for quick bulb changes
- ◆ Adjustable 4-way barn doors
- ◆ Glass heat shield

- ◆ Surface mounted on/off switch
- ◆ Excellent for ceiling bounce lighting
- ◆ 6' straight cord with 120v AC plug

VL-203: Includes DC adapter and 12v 35w DC bulb54.95

VL-205AC: 100 watt AC and 50 watt 12v DC combo light. Includes - AC bulb - DC adapter - DC bulb69.95

VL-205: Includes DC adapter and 12v 50 watt DC bulb59.95

VL-210: Includes DC adapter and 12v 100 watt DC bulb62.95

VL-210AC: 100 watt AC and 100 watt 12v DC combo light. Includes - AC bulb - DC adapter - DC bulb74.95



EQUIPMENT LEASING AVAILABLE

MPL-325

Vima Compact 12v DC Light

This light has all the features you would expect from a more expensive light—but at half the price. The reflector's diameter has been increased 20% but the light itself measures only 3 x 3 x 3". The front housing has 4 adjustable barn doors and removes easily with two tightening screws. Includes a 5600°K dichroic filter for perfect daylight illumination. To satisfy most lighting conditions, you can select from either a 35-, 50- or 100-watt bulb. The power cable is a 6' coiled cord with 120v AC plug end.



- MPL-325J:**
MPL-325 Light with 35-watt bulb and 12v DC Adapter plug.....**109.00**
- MPL-325B:**
MPL-325 Light with 50-watt bulb and 12v DC Adapter plug.....**104.00**
- MPL-325F:**
MPL-325 Light with 100-watt bulb and 12v DC Adapter plug....**109.00**

- MPL-325BAC:**
MPL-325 Light with 50-watt bulb, 12v DC Adapter plug, and 100-watt 120v AC bulb**119.00**
- MPL-325AC1:** MPL-325 Light with 100-watt 120v AC bulb**104.00**
- MPL-325AC2:**
MPL-325 Light with 150-watt 120v AC bulb**109.00**

Self-Contained Lighting Solutions



KLK-35



KLK-10



KLK-3

KLK-35/KL-36

20-watt Lights with On-board Battery Pack

Consisting of the compact VL-30 20-watt light, the lightweight (14 oz.) KLK-35 accepts BP-975XT rechargeable nicad batteries which mount on the light and powers it for up to 22 minutes. Includes 20-watt bulb, BP-975XT battery and 7-hour battery charger**39.95**

The KLK-36 is the same as above except it uses the rechargeable BP-98NMH (Nickel Metal Hydride) battery which mounts on the light and powers it for up to 60 minutes. Includes 20-watt bulb, BP-98NMH battery and 14-hour overnight battery charger**64.95**

KLK-10/KL-20

Compact 10- and 20-watt Lights with Integrated Battery

The KLK-10 is a compact and lightweight 7.4 oz. 10-watt light that has a 900 mAh 6v NiMH internal fit battery that allows it to run for up to 30 minutes. Includes a 10-watt halogen bulb and 4-hour charger**34.95**

The KLK-20 is the same as above except it comes with a 20-watt bulb which runs for up to 15 minutes on a charge. Also includes 4-hour charger**39.95**

KLK-3

3-watt Miniature Light with Rechargeable AAA Batteries

2.5" tall and weighing only 2.3 oz., the KLK-3 runs for up to 30 minutes on two rechargeable 800 mAh NiMH AAA batteries. Includes 3-watt bulb, 2 AAA rechargeable NiMH batteries and 4-hour charger**19.95**

TIFFEN

VIDEO FILTERS

Founded in 1938, Tiffen is the worlds leading manufacturer of glass filters for Still, Video and Motion Picture/Television photography. Tiffen filters are the choice of movie and television producers around the world, and they are the only filter manufacturer honored with two Academy Awards for Technical Achievement, and an Emmy for Engineering Excellence. Tiffen filters are also unique in that they surpass U.S. Military standards and are used by NASA for space photography.



Tiffen filters are made by a unique laminate process developed and patented by Tiffen. The process is a result of two sheets of clear optical glass "fused" together with the use of a special bonding material, which incorporates an exact amount of color. Application of color in this manner is extremely controllable and is not affected by thickness of glass. The inner layer is extremely thin and has a similar refractive index as glass, thus producing similar optical properties as solid glass.

UV Protector Filters

Best lens protection against scratches, dust, dirt, moisture and fingerprints while reducing unwanted ultra-violet light.

Circular Polarizing Filters

Create dramatic color for high visual impact. Darken blue skies, saturate colors, reduce glare and reflections from water or glass by using a Tiffen rotating polarizer. Simply look through your viewfinder as you rotate the filter and stop when you see the desired effect.

Fluorescent FL-D Filters

Improve color and skin tones by eliminating the harsh green cast created by fluorescent light.

Soft/FX Filters

Make people look their best. Soft/FX #3 filters do a powerful job of diminishing fine details, smoothing out wrinkles and blemishes - yet the overall appearance remains sharp, even the eyes. They are also available in other densities. Ideal for people pictures.

812 Filters

Create flattering portraits through improved skin tones. 812 filters are warm tone filters designed to enhance skin tones without substantially affecting other colors in your scene. Ideal when using video lights, the 812 produces skin tones that are less pale and more attractive.

Contrast Filters

Create the look of film on video. Contrast filters reduce the harsh look of high contrast video, giving it more of the look of film. Available in several densities and two types. e.g. Low Contrast Medium #3 lightens shadow areas using the light in the scene.

Neutral Density Filters

Eliminate overly bright, washed out images. Neutral Density filters reduce the amount of light entering your lens without affecting contrast or color. ND.6 will reduce amount of light by 2 f-stops. They are also available in other densities which enable you to create properly exposed images regardless of setting or location.

Filter Size:	30	30.5	37	43	46	49	52	58
UV Protector:	9.25	9.25	9.25	9.25	9.25	9.25	9.25	12.80
Circular Polarizer:	-	34.95	34.95	34.95	34.95	34.95	34.95	36.95
812:	11.25	11.25	11.25	11.25	11.25	11.25	11.25	12.50
Fluorescent FLD:	14.50	14.50	14.50	14.50	14.50	14.50	14.50	18.15
Low contrast #3:	27.95	27.95	27.95	27.95	27.95	27.95	27.95	34.95
Neutral density .6:	11.25	11.25	11.25	11.25	11.25	11.25	11.25	12.45
Soft FX #3:	-	-	30.95	30.95	30.95	30.95	30.95	39.50
Star Effect 4pt, 2mm:	-	-	19.50	19.50	19.50	19.50	19.50	23.50

HOYA/B+W

VIDEO FILTERS

Hoya manufactures a full line of filters for video and photo. The difference between Hoya and other manufacturers is that Hoya filters have one layer of anti-reflective coating applied to each surface of the glass. Other manufacturers' filters are bare glass, and bare glass can reflect as much as 9% of the light hitting it. This greatly increases the risks of flare and ghosting.

Each Hoya filter is the result of research, know-how and complete precision facilities backed by full quality control. Before production starts, controls are first programmed into a computer. Then the finest materials are carefully mixed by an automatic V-blender for absolute uniformity. After being melted with highly sophisticated equipment, this material is then precision molded with automatic direct pressing equipment. The pressed blanks are next slowly and continuously cooled to remove strain, and are then polished by high-speed, double-surface polishing machines that assure precise surface quality.

Next is the coating process which improves the filter's light transmission ability. And the transmission characteristics are checked by Spectro-Phometer, after which an ultrasonic cleaner removes all foreign matter from the surface. Only after passing all of Hoya's quality tests are the filters assembled, finished and made ready for shipment throughout the world.



ACCESSORIES

129

Filter Size:	30	30.5	37	43	46	49	52	58
UV Haze:	-	-	19.95	19.95	19.95	9.95	9.95	11.95
Circular Polarizer:	-	-	-	-	28.95	29.95	29.95	34.50
Fluorescent FLD:	-	-	-	-	14.95	14.95	14.95	17.95
Neutral Density ND 4x:	-	-	-	20.95	14.95	14.95	14.95	17.95
Soft A	-	-	-	-	-	25.50	25.50	28.50
Soft B	-	-	-	-	-	25.50	25.50	28.50
Star 6/8	-	-	-	-	-	20.95	20.95	23.95

B+W Filters



Today, filters are an integral part of the multifaceted photographic process. They can alter light to create desired moods, give colors a new vibrancy, enhance contrast, balance light to film, and make visible that which is invisible to the eye. Special effect filters become creative tools which allow full expression of the photographer's imagination.

Filters fulfill the diverse needs of the most demanding professional photographers and meet the high standards of still-photography, video and precision technology. B&W filters use German Schott optical glass and brass mounting rings.

B&W, a division of of Schneider Optics, benefits the photographer and videographer with a half century of experience in the high quality filter manufacturing field.

Filter Size:	30	30.5	37	43	46	49	52	58
UV Haze:	24.95	24.95	24.95	24.95	19.50	15.50	17.50	19.50
Circular Polarizer:	-	67.10	81.40	75.90	70.50	59.50	59.95	59.50
Fluorescent FLD (499)	-	36.95	46.20	37.40	29.95	29.75	34.25	38.50
Neutral Density .6 (102)	-	20.90	24.20	20.90	19.95	17.50	18.75	20.95
Soft Image	-	-	-	23.10	22.00	18.75	25.50	27.50
Cross Screen 4x	-	-	-	38.50	35.25	33.00	30.95	38.50
Cross Screen 6x	-	-	-	38.50	35.25	33.00	30.95	38.50
Cross Screen 8x	-	-	-	38.50	35.25	33.00	30.95	38.50

ORDER & INFO. (212) 444-5010 • FAX: (212) 239-7770 (800) 947-7008
1-800-947-5525 • www.bhphotovideo.com



KENKO

CAMCORDER LENSES

ACCESSORIES

130

Wide Angle and Telephoto Video Lenses

The smaller size and higher resolution of today's camcorders demand the highest quality optics. Part of the THK family (Tokina, Hoya, Kenko), Kenko incorporates optical technology and manufacturing techniques from two giants of the photo industry—Tokina lenses and Hoya filters—to deliver that quality. So when you purchase a Kenko lens, you can be assured it was made with the most advanced design and fabrication technologies available today. All Kenko lenses are manufactured to precise standards and have been subject to stringent quality control inspections throughout the manufacturing process.



STANDARD SERIES

Made with all glass optics and either metal or polycarbonate barrel material, the Standard Series is designed to give you quality optics for your video camera at the lowest possible price.



KUW-042

The KUW-042 widens the camera's angle of view by multiplying the focal length of the digital/video camera by 0.42 times, which more than doubles the angle of view of the camera. Ideal for landscape video taping or recording in situations where a little curvature of field, or fish-eye effect, is desirable.

KUW-04259.95

SGW-05

Economical, compact and light weight, the SGW-05 (0.5x wide) uses all glass optics and all aluminum lens barrels for quality at an excellent price. Designed as a companion lens to the SGT-20 telephoto, it will double your field of view

KGW-0534.95

SGW-043

This extremely small wide-angle lens packs a large punch when it comes to widening a camera's angle of view. It's a semi-fisheye lens, meaning there is noticeable curvature of field (linear distortion) which people making recordings of extreme sports are looking for.

SGW-04349.95

SGT-20

The light weight SGT-20 (2x telephoto) lens uses all glass optics and all aluminum lens barrels for quality at an excellent price. Designed to be the companion to the SGW-05 wide angle lens, it will double your optical zoom allowing you to bring distant subjects closer without using the camcorder's digital zoom which greatly lowers image sharpness.

KGT-2043.95

	KUW-042	SGW-043	SGW-05	SGT-20	KNW-038
Magnification	0.42x	0.43x	0.5x	2.0x	0.38x
Lens Construction	3E/3G	3E/3G	2E/2G	2E/2G	3E/3G
Mount Thread	46mm	37mm	37mm	37mm	58mm
Adapter Rings included	none	none	none	none	none
Front Filter Thread	none	none	46 mm	46 mm	67 mm
Length	2"	1.4"	1.25"	1.2"	1.8"
Weight	4.9 oz.	4.1 oz.	2.5 oz.	2 oz. (54g)	7 oz. (140g)



ONE HOUR FREE PARKING
AT 349 W. 34th STREET (with purchase of \$100 or more)

KENKO

CAMCORDER LENSES

ACCESSORIES

131

KNW-038

KNW-038 can more than double your camera's widest zoom setting, get more than twice as much area in your video. Get much more of the room in interior shots, capture more of the view in scenic shots. The KNW-038 uses optical glass elements for great picture quality. This lens has a 52mm mount.



KNW-03879.95

KRW-075

This 0.75x wide lens is a hi-grade, wide-angle converter that attaches easily and directly to any camcorder with 58mm filter thread. A stepping ring allows this lens to work DV camcorders having 52mm filter threads. It increases the angle of view by 33%, allowing the video digital camera to take in far more of a scene than normal. This lens is especially suitable for shooting interiors and large groups84.95



KVC-20

A telephoto converter magnifies the focal length of the camera to bring everything closer. The KVC-20 increases the focal length of your camcorder's lens by 2X, bringing things twice as close, throughout the zoom range.

KVC-2064.95



KNT-20

This 2x telephoto lens features all glass optics that are coated to reduce reflections and flare. Elements are housed in an all-metal barrel that will stand up to years of use. The 52mm mount thread makes it well suited to bigger-sized camcorders, but it can be used with smaller ones when used with the appropriate step-up ring79.95



KVC-05

The KVC-05 widens the angle of view by multiplying the focal length of the video camera by 0.5 times. This will double the angle of view, making it an excellent lens for group or wedding videotaping.

KVC-0564.95



KUT-500

A telephoto converter brings everything closer without using the camera's digital zoom feature which "pixelates" the image, making it less sharp. The 5x telephoto extends the focal length of camcorder by five times. Should be used at the upper end of the camera's optical zoom. If used at the wide-angle end, severe vignetting will occur114.95



MD205s



This economical two-lens set is made up of the MD-05W 0.5x wide-angle lens and MD-20T 2.0x telephoto lens. The wide-angle lens allows you to get twice as much in your picture while the telephoto lens can bring distance subjects twice as close as the camera's zoom. Both use high quality optical glass elements and all-metal lens barrels for year of excellent quality video. The two lenses have 37mm mount thread and include 30.5mm and 30mm step-down rings. Silver finished aluminum barrels and high quality glass optics that are coated to guard against reflections and flare.

	KRW-075	KNT-20	KVC-20	KVC-05	KUT-500
Magnification	0.75x	2x	2.0x	0.5x	5x
Lens Construction	2E/2G	3E/3G	3E/3G	3E/3G	8E/5G
Mount Thread	58mm	52mm	clip-on mount ring w/46mm		37mm
Adapter Rings include	none	none	49mm/52mm	49mm/52mm	49mm/52mm
Front Filter Thread	67mm	67mm	none	none	none
Length	1.2"	1.7"	1.7"	2"	4"
Weight	4.9 oz.	6 oz.	5.3 oz.	5.1 oz.	3.8 oz. (105g)

ORDER & INFO. (212) 444-5010 • FAX: (212) 239-7770 (800) 947-7008
1-800-947-5525 • www.bhphotovideo.com



KENKO

CAMCORDER LENSES

PRO SERIES

Designed for the advanced amateur or freelancer, or aspiring documentary videographer, the Kenko PRO series feature all multi-coated glass optics, durable all aluminum lens barrels including metal mount threads and front filter treads. This series encompasses lenses for the Sony DCR-VX2100 and Canon GL-2.

ACCESSORIES

132



K UW-042 PRO

The K UW-042 PRO wide-angle conversion lens is designed for higher resolution DV camcorders. It widens the angle of view by multiplying the focal length of the video camera by 0.42X. This greatly increases the angle of view, making it ideal for group or wedding videotaping.....**89.95**

KRT-20 PRO

A 2.0x telephoto lens for full-sized digital video cameras. The KRT-20 PRO uses multi-coated optical glass for a sharp picture. A lightweight aluminum barrel makes the lens convenient to carry but able to hold up to frequent use.....**49.95**

SGT-20 PRO

The 2.0x telephoto magnification brings things in twice as close as your camera's normal zoom! A super quality telephoto lens for compact video and digital video cameras having a 37mm mount thread. The SGT-20 PRO has crystal clear optical glass elements, which are multicoated to reduce the chance of image ruining reflections.....**84.95**

VC-200 PRO

A tele converter brings everything closer. The VC-200 PRO telephoto extends the focal length of your camcorder's lens 2X, bringing things twice as close, throughout the zoom range.....**129.95**

KAT-300 PRO

A super telephoto 3.0x lens designed for today's ultra-compact digital video cameras. Its high quality glass optics are coated to reduce reflections and yield improve video image. All metal lens barrels insure years for precise performance.**99.95**

	K UW-042 PRO	KRT-20 PRO	SGT-20 PRO	VC-200 PRO	KAT-300 PRO
Magnification	0.42x	0.5x	2x	2x	3x
Lens Construction	3E/3G	5E/4G	3E/3G	3E/3G	3E/3G
Mount Thread	46mm	58mm	37mm	49mm	30.5mm
Adapter Rings include	none	none	none	none	28mm/30mm
Front Filter Thread	none	none	52mm	none	none
Length	1.8"	2.7"	1.5"	2.7"	2.0"
Weight	5.0 oz.	10.0 oz.	3.1 oz.	7.7 oz.	4.1 oz.



CAMCORDER LENSES

PRO SERIES

Designed for the advanced amateur or freelancer, or aspiring documentary videographer, the Kenko PRO series feature all multi-coated glass optics, durable all aluminum lens barrels including metal mount threads and front filter treads. This series encompasses lenses for the Sony DCR-VX2100 and Canon GL-2.

SGW-05 PRO

Kenko SGW-05 Pro wide-angle video conversion lens is designed to be used with compact digital/video cameras that have higher resolution recording ability such as DV formats. The SGW-05 Pro widens the angle of view by multiplying the focal length of the video camera by 0.5 times. This doubles the angle of view, making it an excellent lens for group or wedding videotaping.

This lens features multicoated optical glass lens elements. This reduces the possibility of flare and ghosting caused by light reflecting off the surfaces of the elements and reflecting back into the camera. The inner barrels have a matte-black finish to further reduce the chance of any internal reflections. All barrels and filter threads are made of molded and precision-milled aluminum for long life and lightweight.

KNW-05 PRO II

This top-quality 0.5x wide-angle video conversion lens is designed for cameras with higher resolution recording ability such as DV camcorders. This lens' high quality will match the optical performance of higher resolution formats. It has a wide, 52mm front filter thread for the addition of protective, color correction, special effects filters, or a wide-angle lens hood. All barrels and filter threads are made of molded and precision-milled aluminum for long life and lightweight.

KRW-065 PRO II

This top-quality 0.65x wide lens is a professional-grade, wide-angle converter that when attached, increases the angle of view by 70%, allowing the camera to take in far more of a scene than normal. Even with this wide angle of view, the KRW-065 PRO II has very little barrel distortion, so this lens is especially suitable for shooting interiors and large groups.

The KRW-065 PRO II attaches easily and directly to any camcorder with 58mm filter thread like the Canon GL-2 and Sony DCR-VX2100. A Kenko stepping ring allows this lens to work perfectly with digital video cameras having 52mm filter threads. All barrels and filter threads are made of molded and precision-milled aluminum for long life and lightweight.



	SGW-05 PRO	KNW-05 PRO II	KRW-065 PRO II
Magnification	0.5x	0.5x	0.65
Lens Construction	2E/2G	3E/3G	3E/3G
Mount Thread	37mm	52mm	58mm
Adapter Rings include	none	none	none
Front Filter Thread	55mm	3.4" (85mm)	82mm
Length	1.25"	2.1"	2.1"
Weight	2.5 oz.	8.8 oz.	11.8 oz.

CENTURY OPTICS

DIGITAL SERIES

ACCESSORIES

134

Lens Accessories for Camcorders with 27-37mm Lens Fronts

Pros and advanced amateurs alike are discovering the convenience and capabilities of today's ultra-compact DV camcorders. Yet their adaptability to a wide range of difficult shooting situations is limited by the need for wide options in situations from extreme sports to crowded circumstances. Miniscule yet serious, Century's accessories extend the capabilities of these ultra-compact camcorders without straining your back or your back pocket. Unlike other adapters, these are high-quality optics with the quality you expect from Century. From high-performance glass coatings to durable alloy housings, they are built to the demanding expectations of pros. And pros are finding these cameras useful in difficult shooting circumstances where a full-size camera is impractical for getting that difficult shot.

Designed for the Sony DCR-PC Series, DCR-TRV950 and DSR-PDX10, Canon Elura, Optura and ZR series, and other DV camcorders with 27-37mm lens fronts, these add-ons lenses attach directly to the front of 37mm threaded camcorders, or attach via the supplied 27mm, 30mm & 30.5mm step-up rings. Optional 28mm & 34mm adapter rings are available as well.



FEATURES

3x Mark II Ultra Fisheye Adapter ***Extreme wide angle with barrel distortion***

The new Mark II version is smaller and lighter, yet packs more eye-popping distortion coupled with improved edge-to-edge resolution for outstanding performance.

The new design also features a unique contoured housing which acts as a shade and protects the front element, without adding weight or bulk. Available in popular bayonet and screw in mounts.

The .3X Mark II Ultra Fisheye Adapter offers an extreme fisheye effect and a high degree of barrel distortion. It exaggerates depth by pulling nearby objects closer and causing distant objects to recede into the background. On the Canon Elura, it yields a horizontal viewing angle of 130° (180°, measured diagonally).

With small digital cameras and the Century Fisheye, capturing extreme action shots is dramatic and practical. With its almost total depth of field and unmistakable style, this adapter is a must for action sports shooters.



.55X Wide Angle Adapter ***45% wider with partial zooming***

The .55X Wide Angle Adapter offers a lightweight single-element design that allows you to go substantially wider without noticeable distortion.

This adapter nearly doubles the angle of view and it allows close focusing — right up to the lens front — on many camcorders. When this adapter is attached, angle of view is increased by 45%. Although technically a fixed wide angle adapter, the ability of many cameras to autofocus in macro mode allows this adapter to partially zoom at the wide angle end of the lens.



.65X HR Wide Angle Converter ***High resolution with full zoom capability***



A professional high resolution converter for camcorders with 37mm front threads like Sony DCR-PDX10 and TRV950. To get a wideangle of view with complete zoom-through capabilities, shooters can simply add the .65X HR Wide Angle Converter to the camera lens front, realizing about 35% wider angle of view across the zoom range, wide angle, telephoto, or anywhere in between.

Century offers creative solutions for all your DV camera needs. From wide angle adapters to diopters, fisheyes to matteboxes, they have attachments that will help you get the shot you're looking for. All of their attachments are designed and manufactured to the highest possible standard of quality, using only the best components.



www.bhphotovideo.com

CENTURY OPTICS

DIGITAL SERIES

16:9 Widescreen Adapter

16:9 image without pixel loss

The promise of widescreen video is here — but it wasn't for DV shooters using their in-camera DV widescreen switching. That's because most switchable DV camcorders work by effectively masking the top and bottom of the chip —utilizing only 75% of the original scan lines — resulting in lost resolution and lost angle of view!



- ◆ Some switchable camcorders work by effectively masking the top and bottom of the chip, utilizing only 75% of the original scan lines which results in resolution loss. The anamorphic Wide Screen Adapter instead squeezes the 16:9 image onto the 4:3 chip, utilizing every pixel—for a higher resolution image. When viewed on a 16:9 monitor, the resulting image automatically spreads out to fill the frame.
- ◆ In-camera switching from 4:3 to 16:9 works by cropping into the existing frame (top and bottom), so the resulting widescreen view simply isn't very wide. But Century's anamorphic attachment can reach wider than the lens alone for a considerably more widescreen angle of view. The attachment is used with the camera in 4:3 mode. The resulting images appears vertically stretched in the viewfinder or on a 4:3 monitor. Yet when displayed on a 16:9 monitor, the image automatically spreads out to fill the frame
- ◆ The 16:9 Widescreen Adapter permits partial zoom range on most camcorders

+2.5 Achromatic Diopter

Macro Zoom Attachment

For maximum magnification and image clarity, this Macro Zoom Attachment gives your lenses more close-up range, while preserving zoom capabilities. The +2.5 Achromatic Diopter is essential whenever you need to focus tightly on a small object in tabletop, miniature, and flat field videography. Integral 37mm threads make it easy to connect to the front of your small diameter video zoom. Step-up rings are available to adapt to lens fronts from 27 to 37mm.



- ◆ Common single element diopters permit focusing at close camera-to-subject distances at the expense of image clarity. Instead, this Achromatic Diopters features two highly corrected glass elements which minimize chromatic aberration and distortion.
- ◆ Reduced working distance offers a range of shooting possibilities. Exceptionally crisp videography of small objects like jewelry or computer chips becomes possible.
- ◆ A variety of industrial applications are also made simpler, including remote, high-magnification visual inspection of hard-to-reach objects and manufacturing processes.

ACCESSORIES

135

Digital Series Lenses

	Description	Focal Length	Aperture	Horiz. Angle of View	Effect on Zoom Range	Price
DS-55WA-37	.55x Wide Angle Adapter	Orig. lens x .55	No Light Loss	45% wider than orig	Partial zoom capability	\$79.95
DS-HR65-37	.65x Wide Angle Converter	Orig. lens x .65	No Light Loss	35% wider than orig	Full zoom capability	\$209.95
DS-FEWA-37	.3x Ultra Fisheye Adapter	Orig. lens x .3	No Light Loss	130° horiz/180° vert	Partial zoom capability	\$299.95
DS-1609-37	16:9 Widescreen Converter	Orig. lens x 7	No Light Loss	30% wider than orig	Full zoom capability	\$319.95
DS-HR20-37	Hi Resolution 2x Converter	Orig. lens x2	No Light Loss	—	Partial zoom capability	Call

New! Manual Focus System for the Panasonic AG-DVX100 and AG-DVX100A

A precision manual focus system for the AG-DVX100 or DVX100A, this smart accessory features a user-markable white Delrin focus scale and witness mark that facilitates accurate and repeatable focusing. The unit simply clamp mounts over the 4.5-45mm lens' existing focus scales. There is no lens modification required. The effective lock-out mechanism limits the lens' focus range to 3' to infinity with hard limit stops. Also includes and industry-standard pitch follow-focus gear to facilitate integration with popular professional cine-style follow-focus systems.



ORDER & INFO. (212) 444-5010 • FAX: (212) 239-7770 (800) 947-7008
1-800-947-5525 • www.bhphotovideo.com



CENTURY OPTICS

DIGITAL SERIES

ACCESSORIES

136

Lenses for Standard-Size DV Camcorders

The Digital Series is a family of high quality lenses designed for use on digital camcorders with smaller lens front diameters, like the Canon GL-1/2, JVC GY-DV300/GY-HD1, Sony DCR-TRV900, DCR-VX2000/2100, and the pro versions DSR-PD100/150/170. Also the DSR-200, DSR-200A, DSR-250. The lenses easily attach to the front of these camera's non-interchangeable lenses via bayonet-style mount. Just disengage the factory lens shade, and with a quick twist, the lenses are locked on ready for action. 43-58mm step-up rings to accommodate smaller front lens diameters are also available.



FEATURES

.55X Wide Angle Adapter

45% wider with partial zooming

Here's a low-cost, high-quality wide angle solution. The .55X WA offers a single-element design of negligible size and weight. This adapter nearly doubles the angle of view and it allows close focusing – right up to the lens front – on many camcorders. When this adapter is attached, angle of view is increased by 45%. Although technically a fixed wide angle adapter, the ability of many cameras to autofocus in macro mode allows this adapter to partially zoom at the wide angle end of the lens.

.55x Reversible Wide-Angle Adapter

Wide Angle Adapter & Fisheye in one

The .55x Reversible Wide-Angle Adapter is a dual purpose lens accessory. When attached to the lens front in one direction, the .55x performs like Century's other high quality wide-angle adapters, offering a significantly wider angle of view, with minimal distortion. When you want to go "wow-em" wide with a fisheye effect, simply remove the .55x optical element, flip it around, and thread it on the other way. Voila! It becomes a fisheye adapter. Oriented this way, the .55x provides a wider angle pronounced barrel distortion.

2x Tele-Converter

The 2X Tele-Converter is a front-mounting accessory that provides greater telephoto reach. Available in popular bayonet and 58mm screw mount, the 2X Tele-Converter instantly shifts the focal length range in the telephoto direction. Unlike typical rear-mounted telephoto extenders, the Century Tele Converter provides doubling of the indicated focal length (through the higher end of the zoom range) without light loss, along with front-mounting convenience.

.65x Lightweight Wide-Angle Converter

35% wider with full zoom capability



A tool for capturing a wider angle of view while maintaining full zoom capabilities.

The .65x Wide-Angle Converter attaches to the front of your zoom lens for 35% more coverage when set to wide-angle, telephoto, or anywhere in between. Available in popular bayonet and 58mm screw mount.

3x Ultra Fisheye Adapter MKII

Extreme wide angle with barrel distortion

Available in popular bayonet and 58mm screw mount, this high-performance optic features dramatically improved optics and a lens-saving front shade/protector assembly.

The .3X Ultra Fisheye Adapter offers an extreme fisheye effect and a high degree of barrel distortion. It exaggerates depth by pulling nearby objects closer and causing distant objects to recede into the background. On the Canon GL-2 for example, the .3X Ultra Fisheye Adapter yields a horizontal viewing angle of 125° (180°, measured diagonally). The 35mm focal length equivalent is 13mm.

With small digital cameras and the Fisheye, capturing extreme action shots is dramatic and practical. With its almost total depth of field and unmistakable style, this adapter is a must for action sports shooters.



EQUIPMENT LEASING AVAILABLE

CENTURY OPTICS

DIGITAL SERIES

16:9 Widescreen Adapter for Professional Mini DV Cameras



The promise of widescreen video is here — but it wasn't for DV shooters using their in-camera DV widescreen switching. That's because most switchable DV camcorders work by effectively masking the top and bottom of the chip — utilizing only 75% of the original scan lines—resulting in lost resolution and lost angle of view! In-camera switching from 4:3 to 16:9 works by cropping into the existing frame (top & bottom), so

the resulting widescreen view is only as wide as the 4:3 image. Century's adapter can reach to a full 33% wider angle of view, delivering true widescreen.

- ◆ Some switchable camcorders work by effectively masking the top and bottom of the chip, utilizing only 75% of the original scan lines which results in resolution loss. The anamorphic Wide Screen Adapter instead squeezes the 16:9 image onto the 4:3 chip, utilizing every pixel—for a higher resolution image. When viewed on a 16:9 monitor, the resulting image automatically spreads out to fill the frame.
- ◆ In-camera switching from 4:3 to 16:9 works by cropping into the existing frame (top and bottom), so the resulting widescreen view simply isn't very wide. But Century's anamorphic attachment can reach wider than the lens alone for a considerably more widescreen angle of view. The attachment is used with the camera in 4:3 mode. The resulting images appears vertically stretched in the viewfinder or on a 4:3 monitor. Yet when displayed on a 16:9 monitor, the image automatically spreads out to fill the frame
- ◆ Available in popular bayonet and 58mm screw mount, the Century 16:9 Widescreen Adapter allows for partial zooming — one-half to two-thirds of the range (from wide toward telephoto) depending on available light.

1.33X Anamorphic Focusable Converter for Professional Mini DV Cameras

Capture 16:9 images with 4:3 cameras without sacrificing resolution. A focusable anamorphic attachment squeezes the 16:9 image onto the high resolution camera chip. The innovative focusing design allows use of the camera lens' full telephoto range. The new front-mounted attachment also reaches wider than the lens alone for a considerably more widescreen angle of view. Now also available for Canon XL1S with 16X manual lens.

DS-WS131249



Achromatic Diopters (Macro Zoom Attachments) for 58mm Lenses (+2.0, +4.0, +7.0)

For maximum magnification and image clarity, these Macro Zoom Attachments give your lenses more close-up range, while preserving zoom capabilities. Available in +2.0, +4.0, and +7.0 magnifications, Century Achromatic Diopters are essential whenever you need to focus tightly on a small object in tabletop, miniature, and flat field videography. Integral 58mm threads make it easy to connect the diopters to the front of your small diameter video zoom. Two or more diopters can be stacked on the front of the lens for even more magnification. Step-up rings are available to adapt the Macro Zoom Attachments to lens fronts smaller than 58mm.

Edge-to-Edge Sharpness:

Common single element diopters permit focusing at close camera-to-subject distances at the expense of image clarity. Instead, Achromatic Diopters feature two highly corrected glass elements which minimize chromatic aberration and distortion.

Dramatically Shorter MOD:

An Achromatic Diopter is essential whenever it is necessary to focus tightly on a small subject with a long lens - in tabletop, miniature and flat field photography.



A Closer Look:

Reduced working distance offers a range of shooting possibilities. Exceptionally crisp videography of small objects like jewelry or computer chips is now possible. A variety of industrial applications are made simpler, including remote, high-magnification visual inspection of hard-to-reach objects and manufacturing processes. For example, a camera and lens equipped with an Achromatic Diopter might be used to get an extremely accurate close-up view of signatures moving through a printing press.

CENTURY OPTICS

PRO DV SERIES

ACCESSORIES

138

Lenses for Canon XL-1s and Panasonic AG-DVX100A

Century's Pro DV Series offers quality professional lens accessories designed to help you go wider, reach further, and move in closer than the lens alone allows. Century's superb optics provide the finest professional images. These state-of-the-art accessories minimize chromatic aberrations and unwanted distortion & produces images that are ultra sharp edge-to-edge.

Mounting and removing accessories is quick and easy. Pro DV adapters and converters interface directly with the bayonet mount at the front of the lens, locking & unlocking with a simple twist. There's no threading and no jamming.



Fisheye Adapter



When you're shooting for an exaggerated point of view, twist on the Pro DV Series Fisheye Adapter. The Fisheye gets you a wider view with pronounced barrel distortion and no vignetting.

The fisheye exaggerates depth, pulling nearby objects closer, and causing distant objects to recede into the background. A fixed adapter, the Fisheye doesn't allow for zooming — but you'll want to stay at the wide end of the range anyway, for the most pronounced effect.

On the DVX-100 this non-zoom-thru add-on provides approximately 2.3mm focal length, 92° horizontal angle of view and weighs only 7.6 oz.

Century makes the Fisheye adapter for Canon's 16X lenses and another for 3X lenses. Starting with the already wide angle 3:1 makes for even more impressive coverage. So while the 16X version offers an approximate effective focal length of 2.7mm (an 85° angle of view), the Fisheye at Canon's 3X lens achieves an approximate effective focal length of just 1.5mm (a 116° angle of view).

.6X Wide Angle Adapter

Ideal for shooting situations in which zooming isn't needed. The .6X attaches to the front of your video zoom lens for 40% wider angle of view and minimal distortion.

On the DVX-100's 10x lens it allows partial zooming up to mid-range while in Auto Focus (loses focus beyond 5X). The resulting focal length is 2.7-13.5mm with a 84-21° horizontal angle of view).

On the XL-1/XL-1s it allows partial zooming up to 8X while in Auto Focus (loses focus beyond 8X). The resulting focal length is 3.3-26mm with a 72°-10.33° horizontal angle of view).

.7X Wide Angle Converter

Century's .7X Wide Angle Converter attaches quickly to the front of your zoom, offering a 30% wider angle of view and full zoom-thru capabilities.

The converter slips onto the front of the XL-1/XL-1s 16X zoom with a one-handed twist resulting in an effective focal length nearly as wide as the Canon 3x (within half a millimeter) and zooms six times as far. It shifts the focal length range from 5.5-88mm to 3.85-61.6mm — with no appreciable light loss.

On the DVX100's 10:1 zoom the .7X shifts the focal length range from 4.5-45mm to 3.1-31.5mm — with no appreciable light loss.

1.6X Tele-Converter

Add the 1.6X Tele-Converter to the front of your zoom lens to shift its focal range in the telephoto direction. The perfect tool when it's inconvenient, dangerous, or even impossible to move as close to the subject as you'd like.

On the XL-1/XL-1s, the 1.6X converter alters your zoom's focal length range from 5.5-88mm to 56-140mm — with no appreciable light loss.

On the AG-DVX100/AG-DVX100A the 1.6X converter alters your zoom's focal length range from 4.5-45mm to 36-72mm — with no appreciable light loss.

The 1.6x is specially effective in "run-and-gun" shooting situations because it attaches quickly to the front of the existing lens on the AG-DVX100/AG-DVX100A; attaches more quickly than rear-mount tele-extenders, and doesn't require exposure of the XL1's delicate electronics.

Need even more telephoto range? Add the Century 1.6X Tele-Converter to the front of your lens and Canon's 1.6X Tele-Extender to the rear, for the widest possible range —17.6-225mm, with no vignetting.



www.bhphotovideo.com

CENTURY OPTICS

DIGITAL and PRO DV SERIES

Digital Series Lenses — What they do for you

		Description	Focal Length	Aperture	Horiz. Angle of View	35mm Equivalent	Zoom
Results using the Canon GL-1/GL-2	DS-55WA-GL	.55X Wide Angle Adapter	2.3-23mm	f/1.6	77°-9.2°	22-220mm	Partial
	DS-65CV-GL	.65X Wide Angle Converter	2.7-54.5mm	f/1.6-f/2.9	67.5°-3.8°	26-523mm	Full
	DS-FEWA-GL	.3X Ultra Fisheye Adapter	1.26mm	f/1.6	125°	12mm	Partial
	DS-1609-GL	16:9 Widescreen Adapter	4.7-37.5mm	f/1.6	54°-7.3°	35.2-281.2mm	Partial
	DS-20TC-GL	2X Tele-Converter	56-168mm	f/1.6-f/2.9	3.7°-1.3°	537-1612mm	Partial
Using Sony DCR-VX2000, DCR-VX2100, DSR-PD150, DSR-PD170, DSR-250	DS-55WA-SB	.55X Wide Angle Adapter	3.3-19.8mm	f/1.6	72°-13.8°	24.8-148.5mm	Partial
	DS-65CV-SB	.65X Wide Angle Converter	3.9-46.8mm	f/1.6-f/2.4	63.2°-5.9°	29.25-351mm	Full
	DS-FEWA-SB	.3X Ultra Fisheye Adapter	1.8mm	f/1.6	125°	13.5mm	Partial
	DS-1609-SB	16:9 Widescreen Adapter	4.7-37.5mm	f/1.6	54°-7.3°	35.2-281.2mm	Partial
	DS-20TC-SB	2X Tele-Converter	72-144mm	f/1.6-f/2.4	3.8°-1.9°	540-1080mm	Partial
Using Sony DCR-VX1000, DSR-200, DSR-200A	DS-55WA-00	.55X Rev. Wide Angle Adapter	3.25mm	f/1.6	73° WA, 92° Fisheye	24.2mm	Partial
	DS-65CV-00	.65X Wide Angle Converter	3.8-38mm	f/1.6	64°-10°	28.6-286mm	Full
	DS-FEWA-00	.3X Ultra Fisheye Adapter	1.77mm	f/1.6	125°	14mm	Partial
	DS-1609-00	16:9 Widescreen Adapter	5.1-25mm	f/1.6	50.4°-11°	38.4-192mm	Partial
	DS-20TC-00	2X Tele-Converter	39-118mm	f/1.6	7.4°-2.3°	290-880mm	Partial
Using Canon XL-1 & XL-1s with 16x IS zoom lens	VS-06WA-XL2	.6X Wide Angle Adapter	3.3-26mm	f/1.6-f/2.6	72°-10.33°	24-188mm	Partial
	VS-07CV-XL	.7X Wide Angle Converter	3.85-61.6mm	f/1.6-f/2.6	64°-4.5°	28-458mm	Full
	VS-FEWA-XL	Fisheye	Approx. 2.7mm	f/1.6-f/2.6	85°	19mm	Fixed
	VS-16TC-XL	1.6X Tele-Converter	56-140mm	f/1.6-f/2.6	4.54°-1.57°	404-1010mm	Partial
	VS-16TC-XL	1.6X Tele-Converter and Canon 1.6X Tele-Extender	17.6-225mm	f/2.56-f/4.1	15.3°-1.13°	127-1625mm	Full
Using Canon XL-1 and XL-1s with manual 16x lens	VS-06WA-MXL	.6X Wide Angle Adapter	3.24-26mm	f/1.6-f/2.6	72°-10.33°	24-188mm	Fixed
	VS-07CV-MXL	.7X Wide Angle Converter	3.8-60.5mm	f/1.6-f/2.6	64°-4.5°	28-458mm	Full
	VS-FEWA-MXL	Fisheye	Approx. 2.7mm	f/1.6-f/2.6	85°	19mm	Fixed
	VS-16TC-MXL	1.6X Tele-Converter	56-138.3mm	f/1.6-f/2.6	4.54°-1.57°	404-1010mm	Partial
	VS-16TC-MXL	1.6X Tele-Converter and Canon 1.6X Tele-Extender	17.6-222mm	f/2.56-f/4.1	15.3°-1.13°	127-1625mm	Full
Using Panasonic AG-DVX100 or AG-DVX100A	VS-06WA-DVX	.6X Wide Angle Adapter	2.7-13.5mm	f/1.6	84°-21°	20-100mm	Partial
	VS-07CV-DVX	.7X Wide Angle Converter	3.1-31.5mm	f/1.6	75°-9°	23.5-238mm	Full
	VS-FEWA-DVX	Fisheye Adapter	2.3mm	f/1.6	92°	17mm	Partial
	VS-FE3X-DVX	.3X Ultra Fisheye Adapter	1.4mm	f/1.6	130°	14mm	Partial
	VS-16TC-DVX	1.6X Tele-Converter	36-72mm	f/1.6	7.5°-3.8°	280-560mm	Partial

58 mm Threaded Accessories

Using Sony DCR-TRV900, DSR-PD100A, JVC GY-HD1 & GY-DV300	DS-55WA-58	.55X Rev. Wide Angle Adapter	Orig. lens x .55	No light loss	45% wider than orig	Partial
	DS-65CV-58	.65X Wide Angle Converter	Orig. lens x .65	No light loss	35% wider than orig	Full
	DS-FEWA-58	.3X Ultra Fisheye Adapter	Orig. lens x .3	No light loss	125° horiz/180° vert	Partial
	DS-1609-58	16:9 Widescreen Adapter	Orig. lens x .7	No light loss	30% wider than orig	Partial
	DS-20TC-58	2X Tele-Converter	Orig. lens x .2	No light loss	N/A	Partial

*These camera models require a 52-58mm Step-up Ring. Request a FA-5258-00 at time of order.

ORDER & INFO. (212) 444-5010 • FAX: (212) 239-7770 (800) 947-7008
1-800-947-5525 • www.bhphotovideo.com



CENTURY OPTICS

LCD MAGNIFIER

ACCESSORIES

140



Ideal Tools for Viewing LCD Screens

An exciting accessory for DV cameras, the LCD Magnifier alleviates many of the problems associated with today's LCD screens. The LCD Magnifier slips over existing flip-out 2.5" diagonal LCD screens on the Sony DSR-PD150/170, DCR-VX2000/VX2100, Canon GL-1 & GL-2, JVC GY-DV300 and similar camcorders. Offering 1.8-2X magnification, it incorporates superior quality multi-layer coated glass elements for minimized refraction and crisp viewing even in bright sunlight. Weighing just 2 oz. it readily slides on and off in seconds. Comes in a handsome leatherette pouch.

- ◆ For those who have trouble figuring out what it is that we're looking at on those tiny LCD screens, the LCD Magnifier is the perfect solution. A factor of 1.8-2x magnification will let you see everything you need to from a comfortable distance. No more having to get right up against the screen to frame your shot.
- ◆ You don't always want to be looking through the eye-piece while you're shooting. That's why you got a camera with an LCD in the first place! But you know that with the small low resolution screens of many popular consumer cameras, finding focus or even just seeing the image can be next to impossible.
- ◆ The larger image of the LCD Magnifier, its anti-reflective coating, and a 2-inch "neck" combine to give you a larger, clearer view of the LCD free from glare and reflections even in bright sunlight.
- ◆ Sturdily constructed out of polystyrene that will stand up to rigorous use, the LCD Magnifier is designed for ease of use and optimum effectiveness. It has two parts: a mount/sunshade assembly that slips onto the LCD screen and a detachable housing for the magnification optic. The housing is secured by two thumbscrews and can be moved up and down to adjust magnification level or removed completely, allowing it to function as an exceptional sunshade whose 2-inch depth blocks out most of the sun's rays.

DS-LCDM-00: LCD Magnifier for 2.5" flip-out LCD**169.95**

DS-LCWS-00: LCD Widescreen Converter for 2.5" flip-out LCD monitors when using the Century 16:9 Widescreen Adapter**199.95**

DIGITAL SERIES SUNSHADE/FILTER HOLDERS

Protect your Camera Lens, Enhance your Creativity

There's more to Century's family of light control solutions. Century's rectangular Sunshade/Filter holders are designed for use on the Canon GL-1/GL-2, Sony DSR-PD150/170, DCR-VX2000, DCR-VX2100 and similar size camcorders. They easily slip onto the front of any Century DV product (except for the fisheye) and are secured by tightening a single lock screw. Available in two versions, depending on your needs and budget.



DS-FA82: This affordable rectangular Digital Series Sunshade/Filterholder slips onto most lenses and Century accessories; accepts one 82mm screw-in filter**159.95**

DS-FH44-00: This rectangular Sunshade/Filterholder holds one or two 4" x 4" glass filters. Perfect for precise control with grads and soft-focus filters.....**339.95**

VS-FH44-00: Rectangular Sunshade/Filterholder for Pro DV accessories (0.6x Wide Angle Adapter and 0.7x Wide Angle Converter for Canon XL-1/XL-1s); holds one or two 4" x 4" glass filters**339.95**

DS-RPOL-44: Schneider rotating 4x4 Tru-Polarizer for use in the DS-FH44-00 and VS-FH44-00**199.95**

FA-5880-00: 58mm to 80mm step-up shade adapter (required when using non-Century lenses).....**34.95**

Sunshade/Filterholder fits some Pro DV lenses. Accepts one 4.5" drop-in filter.

VS-FA90-00: Sunshade/Filterholder 4.5", 90mm**159.95**

VS-FA95-00: Sunshade/Filterholder 4.5", 95mm**159.95**

VS-FA00-00: Sunshade/Filterholder 4.5", 105mm**189.95**



CENTURY OPTICS

DV MATTE BOX

Light Filtration and Management System

Packed with features that protect your camera and enhance your creativity, the Century DV Matte Box mounts directly to most DV cameras — only a soft rubber lens ring contacts your lens barrel, so you don't have to worry about your lens during the bumps and grinds of capturing exciting footage. Precision engineered and manufactured with the finest materials, the Century DV Matte Box comes fully equipped with everything needed for typical operation, plus accessories for special applications.

The well designed camera mounting system is easily adjusted to fit both vertical and horizontal requirements of your camera body and lenses. Best of all, the Century DV Matte Box is ideal for use with your Century DV accessories (except Fisheye) up to 95mm in diameter. The system comes with 6 rubber lens rings to fit most cameras.



ACCESSORIES

141



- ◆ Patented, movable eyebrows provide extra flare reduction; adjustable to the zoom position of the operating lens.
- ◆ An accessory shoe for fast and simple attachment of a light or microphone holder.
- ◆ Cine-style rails provide solid, quick adjusting support.
- ◆ Rotating filter stages accept holders for 4" x 4" filters; perfect for polarizers and effects filters.
- ◆ Soft rubber lens rings keep light from entering the rear of the Matte Box. Five sizes to fit virtually any lens are included.

DV Matte Box 4x4 (12mm Rod) Systems

DS-MB44-00:

With two 4x4 holders, 12mm rods and matte box support. Off-lens mounting for universal fit and lens safety, adjustable eyebrow. Fits the Canon GL-1/GL-2 and XL-1/XL-1s, Sony DCR-TRV900/950, DCR-VX2000/VX-2100, DSR-PD100A/150/170 and DSR-PDX10.....**699.00**

DS-MB44-DVX:

With two each 4x4 holders, 12mm rods and matte box support. Off-lens mounting for universal fit and lens safety, adjustable eyebrow. Exclusively for the Panasonic DVX-100 and DVX-100A.....**769.00**

DS-MBFF-00: French Flag.....**799.00**

DS-MBTS-00: Tripod Spacer.....**49.95**

DV Matte Box 4x4 (15mm Rod) Systems

DS-MB44-S0:

With two 4x4 holders, heavy duty 15mm rods and matte box support. Off-lens mounting for universal fit and lens safety, adjustable eyebrow. For the Sony DSR-250/300/500 and JVC DV-5000U.....**899.00**

DS-MB44-JV:

Same as above, for the JVC DV-500.....**999.00**

DS-MB44-XL:

Same as above, for the XL-1/XL-1s.....**999.00**

DS-MB44-D15:

Same as above, for the DVX-100/DVX-100A.....**1099.00**

DS-MBFF-00: French Flag.....**79.95**

ORDER & INFO. (212) 444-5010 • FAX: (212) 239-7770 (800) 947-7008
1-800-947-5525 • www.bhphotovideo.com



VIDEO INNOVATORS

S-800

Camcorder Shoulder Rest

Now you can hold your camcorder steady with less fatigue and enjoy the mobility it was designed for when "shooting on-the-shoulder".

Available in three styles, there is a S800 Shoulder Rest model to help you produce smooth, professional looking videos.

The S-800 Standard can be used with most Hi8, Digital8

and DV camcorders, while the PRO model is the same, plus offers

an extra-wide shoulder cushion. The S-800 Super-Pro's camera

platform is hinged from the shoulder cushion, so it can be moved laterally for different eyepieces, and a pivot-hinge, mounted

in a 3" long slot for length adjustments. With the mounting screw in a 31/2" slot, the S-800 Super Pro has a total adjustment of 6 1/2", accommodating almost any Hi8, Digital8 and DV camcorder.



S-800 Standard (103)

- ◆ Handle design lets you use your other hand for further steadying, while giving you control of all camera functions.
- ◆ Use with either hand and either shoulder
- ◆ Adjustable for proper eyepiece spacing
- ◆ Threaded hole for direct tripod mounting
- ◆ Thick foam rubber shoulder padding
- ◆ Black urethane finish and welded construction for long lasting beauty.

S-800 Standard.....44.95

S-800 Pro (106)

- ◆ The S-800 Pro has all the features of the S-800 Standard, plus it offers a 3" wide shoulder cushion with more supple padding. The extra-wide cushion provides maximum comfort and stability for longer shoots. Simulated leather cushion gives it a more professional appearance.
- ◆ Includes an accessory bar to accommodate an LCD monitor or video light.

S-800 Pro69.95

S-800 Super-Pro (125)

- ◆ The shoulder cushion features a contour that conforms more comfortably to the slope of the shoulder - it is thinner on the inside and thicker on the outside.
- ◆ Can accommodate two accessories, such as LCD monitor or video light.
- ◆ Folds to less than 12" for easy storage.
- ◆ Adjustable length of 6 1/2" and lateral adjustment of over 90°.

S-800 Super-Pro.....84.95



\$24⁹⁵

TS-1000 Camcorder Table Stand

The TS-1000 is a table stand that provides a safe, stable platform for your camcorder while playing, editing or dubbing. The TS-1000 attaches to your camcorder in seconds and easily folds out of the way when not in use. Its large platform securely holds all sizes of camcorders weighing up to 5 lbs.

- ◆ Made of solid aluminum construction, the TS-1000 supports camcorders up to 5 lbs.
- ◆ Makes it easier to connect cables and keeps them out of the way.
- ◆ Snaps open and attaches in seconds. Folds up and locks flat when not in use.

CH-1000 Camcorder Handle

Designed for small Digital8 and DV camcorders, the CH-1000 provides a solid, comfortable grip while stabilizing the camera for skillful taping. Attaching in seconds, the CH-1000 can be used with either hand and makes taping easier, less fatiguing.

- ◆ Specially designed handle bracket locks in three positions:
 - Locks straight down for camcorders having sports viewfinders.
 - Locks at a 45° angle for taping with direct eye-to-viewfinder contact
 - Locks flat for easy storage and carrying in a camera bag



\$26⁹⁵

- ◆ Small and lightweight, it can be left on all the time. Measures 5" long by 1 1/2" in diameter.
- ◆ Molded foam rubber handle provides all-day comfort



For Any Inquiries Regarding Your Order, Call Our Customer Service:
 (800) 221-5743 • (212) 239-7765 • FAX: (800) 947-2215 • (212) 239-7549

MIGHTY WONDERCAM

CAMERA SUPPORT

Classic

Need to steady your shot? Or need a place to mount accessories like mics, lights, radios? The Mighty Wondercam Classic is a unique shoulder pod system for small camcorders that has been used by Discovery Channel, PBS, CBS News, schools, and wedding and event videographers around the world.

A rugged, comfortable, lightweight aluminum shoulder pod, the Classic has five axes of adjustment, to comfortably fit most camcorders and camera people. And it has seven mounting points for accessories such as external mics, batteries and radio receivers. The rotating, cushioned handgrip comes with a removable stainless-steel foot. Mounts easily to a tripod and weighs just 2.5 pounds (1.1kg).

And if you need extra support with the Classic, just add the optional Ab Pad. A virtual belly brace, the Ab Pad is an adjustable, machined-aluminum pole that attaches to the nose of the Classic.

CLASSIC.....179.95 With Ab Pad.....239.95



Mini-Rover

A unique compact, lightweight and sturdy all-metal "L-shaped" bracket, the Mini-Rover is ideal for mounting accessories such as mikes or lights in the shoe above the cushioned handgrip. The versatile padded camera platform has anti-twist pins to keep the camera stable, plus standard tripod mounting holes.

MINI-ROVER.....49.95

Rover

Tired of dangling cables and pockets crammed with accessories? In one compact package, the Rover brings a unique flexibility to DV camcorders and greatly expands your audio capability. The box beneath the camera holds a radio mic receiver, while the arm provides a mounting shoe for an external ambient mic. The box also mounts to a tripod or monopod. Built entirely of machined aluminum, the Rover is light (1lb.), comfortable to use and extremely versatile.

ROVER.....179.95



Ultimate Rover

Same as the Rover, the Ultimate Rover adds a built-in Beachtek DXA dual XLR adapter to give you precise control over two balanced audio inputs (switchable between mike and line level) and individual channel pots. Using the optional Roverlink XLR-XLR cable, you'll wield a powerful video production tool in a rig not much larger than the camera itself—with better handling. Built entirely of machined aluminum, the Ultimate Rover is light, comfortable to use and extremely versatile.

ULTIMATE ROVER.....369.95

Mighty WonderCam Accessories

ROVERPOD:

Lightweight monopod, extends from 20 to 60".....69.95



AUXBOX:

Auxiliary box mounts below Rover or the Ultimate Rover, so you can add a radio mike or a battery.....79.95

ROVERSTOCK:

Shoulder brace for extra support when shooting with the Ultimate Rover.....19.95

SCREWIT:

1/4-inch to standard 5/8" thread adapter, mounts to top of either Rover.....7.95

ROVERLINK:

18-inch XLR-XLR cable.....22.95

GUERRILLA BOOK:

3x3 gel swatches to help fine-tune white balance settings.....14.95

VARIMOUNT:

Adapter for attaching Varizoom grip handles directly to the Mighty WonderCam Classic.....19.95

VARIZOOM

VZ-LSP



Professional Shoulder Support System

One of the biggest drawbacks of DV camcorders is their lack of a proper shoulder mount. With the VariZoom VZ-LSP this problem is a thing of the past. The VZ-LSP is the ultimate shoulder brace, providing no less than ten adjustable fittings for an endless variety of shooting configurations—while eliminating arm fatigue caused while holding the camera and support system. Shoot fatigue free all day with camcorders up to 8 lbs. with cameras such as the Canon XL-1s on your shoulder.

Separating this brace from its competitors is the fully ab support (included), giving you three points of contact with the brace (hand, shoulder and body) for maximum camera support and control. The camera mounting platform can be positioned exactly as desired, raising the viewfinder right to your eye.

Precision crafted from machined aluminum, the VZ-LSP is tough,

lightweight and built to last. And it can be customized by adding a VariZoom VZ-PG-L, VZ-Pro-L or StealthZoom lens controller giving you the perfect combination for getting the best looking video with comfortable hand-held shooting.

FEATURES

- ◆ The VZ-LSP insures a stable shooting platform by providing three points of body contact: shoulder, hand and abdomen.
- ◆ The VZ-LSP can be configured with or without the ergonomical abdomen pad depending on shooter preference.
- ◆ Precision-machined from sturdy, light-weight aluminum, offers extended periods of hand-held shooting with maximum comfort.
- ◆ Ab Support clutch is machined from metal with serrations for secure clamping
- ◆ Adjustable pivoting shoulder pad can fit all body types; allows position to change depending on users and varying situations; allows for maximum comfort.
- ◆ Attach your camcorder to the shoulder brace camera platform using the camera's tripod mounting receiver with the included knurled screw. Then position the camera platform (forward, back, up or down) so that the viewfinder or LCD monitor meets the eye comfortably.
- ◆ Folds up for portability
- ◆ Designed specifically for popular "prosumer" camcorders which are smaller than traditional shoulder-mount cameras, including the Sony DCR-VX-2000, DCR-VX2100, DSR-250, DCR-TRV900/TRV950 and Canon GL-1/GL-2 and XL-1/XL-1s.
- ◆ Ten adjustments for best fit and control, including:
 - **Shoulder Brace:** up & down
 - **Top Bar:** swing left & right
 - **Top Bar:** slide up & down
 - **Top Bar:** tilt up & down
 - **Cam Mount:** up/down forward/backward
 - **Ab Support:** clutches at any angle
 - **Ab Support:** telescopes in & out
 - **Ab Support:** plate tilts up & down

VZ-1 Shooter

- ◆ Built in 'Kickstands' for stability
- ◆ Designed to be customized to your shape
- ◆ Works with all DV Camcorders
- ◆ Includes the Varizoom VZ-PGB Bracket Grip Bracket. An innovative right-angle bracket the VZ-PGB attaches to the mounting clamp on the VZ-Pro-L controller, and converts it into a convenient pistol-grip handle for DV camcorders. Hand-held shooting becomes much easier and more comfortable, while providing precise zoom and focus control.....79.95



EQUIPMENT LEASING AVAILABLE

VARIZOOM

STEALTHPOD

High Quality Monopod for Compact DV Camcorders

VariZoom's StealthPod allows for unbelievably smooth jitter free shots like that of similar more expensive steady systems. Videographers can now sit on a bench and wait for a shot with the telescoping pod adjusted at eye level and the bottom resting on the ground. Be relaxed and ready for the next shot, whatever it might be. When "the shot" comes, quickly adjust the telescopic leg to length and hurry in with no shaking or mic noise, which has plagued videographers for years. When used with the VariZoom StealthZoom, you get a high quality monopod and control of your camcorder!

- ◆ The StealthPod is a super sleek pod designed specifically for the popular "prosumer" one-piece Digital8 and DV camcorders, including the Sony DCR-VX2000/VX-2100, DCR-TRV900/TRV950, DSR-PD-150/170, PC-109/330; and Canon's GL-1/2, Optura and Elura series. It is designed to aid in getting that steady, shake-free shot that everyone wants!
- ◆ The StealthPod can be used to balance and steady a small to medium size camcorder by adjusting the telescoping leg. The leg can be extended from 23" to over 5½'. quick enough to get that rock solid shot at a moments notice.
- ◆ To connect, just screw the supplied quick release plate to the bottom of your camcorder, slide the plate on top of the StealthPod's docking station and it locks in place, thats it!



ACCESSORIES

145

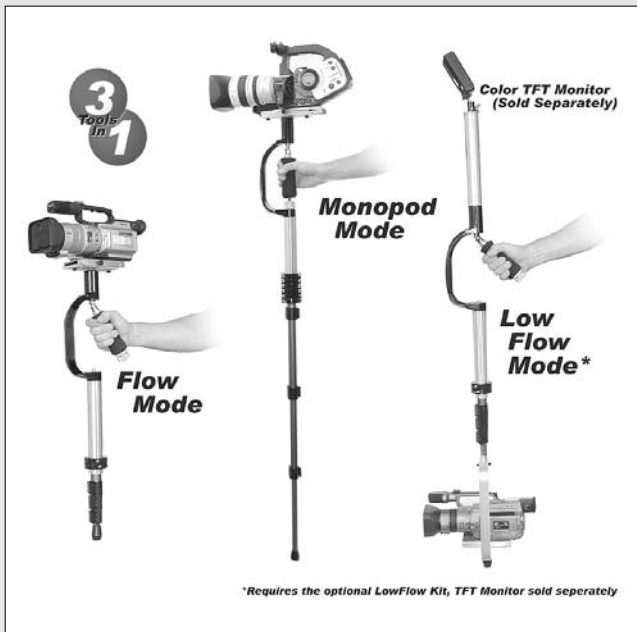

FLOWPOD

The Ideal Stabilizer — Three Tools in One!

A uniquely styled device, the FlowPod is the most versatile piece of support gear on the market. Designed to work perfectly with or without a VariZoom control, the FlowPod merges the popular StealthPod monopod with a new patent-pending stabilizing system. The key is the patent-pending locking pivoting foam handle grip. This unique multi-purpose handle features a telescoping pin that can either be locked in-line for use as a monopod or unlocked to allow free floating action shots. The slim design allows for ease of use in the tightest of shooting situations. But the FlowPod's versatility does not stop there. There is also an optional LowMode kit allowing for low mode shots that until now have only been available in rigs costing thousands.

For too long, users of stabilizing devices have had to balance their stablizer while holding it, causing unnecessary fatigue and poor balance. To solve this problem, the FlowPod is equipped with the VZ-FPB balancing plate and clamp. Now, FlowPod users can easily and accurately balance their FlowPod without the need to purchase extra accessories.

- VZ-FP: Includes the FlowPod with the VZ-FPB Balancing Plate and Clamp.....374.95
 VZ-FPC: Same as above plus it adds a custom carrying caseCall
 VZ-FPK: Same as above plus it includes the LowMode Kit.....Call

ORDER & INFO. (212) 444-5010 • FAX: (212) 239-7770 (800) 947-7008
1-800-947-5525 • www.bhphotovideo.com



VARIZOOM

VZ-PRO-L/VZ-PG-L

Remote Zoom & Focus Controllers for LANC-equipped Camcorders

A true variable speed and manual focus controller, the VZ-Pro-L and VZ-PG-L use the Control-L (LANC) terminal to control any Sony or Canon DV camcorder. The combination zoom rocker and speed control dial allows you to vary speeds in a single movement — smoothly from a slow crawl to fast and then slow again. Users can “set and forget” any single speed zoom as well as manually ramp up and down the speeds while zooming. The VZ-Pro-L will allow full control over all speeds of any camera it is connected. Also features manual focus control, a “wake-up from standby” switch, a recording light indicator, and a universal tripod/crane mounting clamp. Ideal for use with VariZoom’s VZ-LSP and VZ-1 shoulder support systems. The VZ-PG-L is the same as the VZ-Pro-L but with a body style to accommodate users with smaller hands.



FEATURES

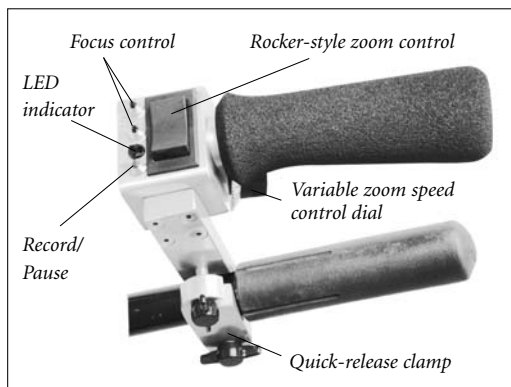

- ◆ The VZ-Pro-L and VZ-PG-L send zoom and focus commands through the camcorder’s built-in LANC protocol, which is standard in all Canon and Sony Digital8 and DV camcorders on the market today.
- ◆ Precision variable-speed control over camera zooms. Ramp up from slow to fast and then slower again in a single move.
- ◆ Push-button manual focus is conveniently at your fingertips so you can precisely adjust the focal plane within a shot.
- ◆ Wake-up from standby mode: when the camera automatically powers down into sleep mode, you can push a button on the VZ-Pro-L and VZ-PG-L and be ready to shoot immediately.
- ◆ LED light indicates recording, low battery power, tape out and other signals.

- ◆ The VZ-Pro-L and VZ-PG-L are compact remote lens controllers designed specifically for today’s popular “prosumer” one-piece DV camcorders, including the Sony DCR-VX-2000/VX2100, DSR-200/250, DSR-PD100A/PD150/PD170, DCR-TRV900/TRV950 and Canon GL-1/GL-2, XL-1/XL-1s, Optura and Elura (with docking station).
- ◆ 40” LANC cable is built in to the unit
- ◆ Tripod handle configuration with rubberized foam grip for maximum operator comfort.
- ◆ Heavy-duty clamping system allows operator exceptional control over tripod and camera functions simultaneously with one hand.
- ◆ Precision machined from high grade aluminum with a beautiful brushed finish.
- ◆ Run your camcorder without having to touch it. No more undesired noise from fingers bumping the mic and lens, etc.
- ◆ To connect, just plug the controller cable into your camcorder’s Control-L (LANC) jack. That’s all there is to it! Does not require any modification or alteration to your camera. Use them hand-held, or clamp the controller to your tripod pan handle.

Zoom and Focus Controls

VZ-Pro-L: Professional control for DV camcorders with LANC jack.....	349.95
VZ-PG-L: Pistol grip professional control for DV camcorders with LANC jack	359.95
VZ-Stealth: Economical miniature control for DV camcorders with LANC jack.....	259.95
VZ-StealthLX: Full-featured control for DV camcorders with LANC jack	219.95
VZ-Rock: Full-featured variable rocker control for DV camcorders with LANC jack ..	319.95
VZ-Rock-DVX: Full-featured variable rocker control for Panasonic AG-DVC30, AG-DVC80, DVX100/DVX100A.....	269.95
VZ-Stealth-DVX: Full-featured variable rocker control for Panasonic for AG-DVC30, AG-DVC80, DVX100/DVX100A	189.95



VARIZOOM

STEALTHZOOM

Compact Zoom & Focus Controllers for LANC-equipped Camcorders

A high quality yet economical alternative to VariZoom's Pro-L and PG-L professional line of controls, the StealthZoom is a "must have control" for all videographers when low price and/or small size is a factor. The StealthZoom is an affordable and versatile controller. It's lightweight and compact size with a thumb-style rocker throttle on top allow this controller to fit nearly anywhere and on nearly any device such as stabilizers, monopods, and even on the handle of the camera itself.



The StealthZoom allows for slow crawls to medium high speeds but will not do the fastest zooms on some 3-CCD camcorders. Great for small to large hands. It is easy for anyone to use and has all the necessary functions for control.

- ◆ Unique variable speed zoom thumb control lets you maintain the slowest crawl or gradually ramp up speed and then decrease speed gradually all in one smooth motion! Because your thumb never leaves the speed control you have quick response time and smooth actions to zoom in/out, faster/slower. Simply push forward to zoom in (telephoto) and pull back to zoom out (wide). No shaking the camera or time lost fumbling to find the right button to zoom in or zoom out.
- ◆ The intuitive rocker focus control provides you with smooth ergonomic control. Place your thumb in center of the rocker and move thumb forward to focus near or shift your thumb back to focus far. This is the only rocker control of it's kind that doesn't share the rocker for both zoom and focus. Separate controls for zoom and focus is essential for quick active response times. No time will be lost switching back and forth with a shared control.
- ◆ A low profile record button avoids accidental activation
- ◆ LED indicates recording, low battery, tape out and other signals.
- ◆ 40" LANC cable is built in to the unit
- ◆ Power-On from Stand-by mode: when the camera automatically powers down into sleep mode, you can push a button on the StealthZoom and be ready to shoot immediately.

StealthLX Step-up Features

All the features of the StealthZoom, the StealthLX adds an autofocus button, shuttle search control and on-screen data control.

- ◆ Shuttle search control lets you surf through your tape with Frame Forward (F+) and Frame Reverse (F-) shuttle buttons. Press this button once and it surfs through your tape one frame at a time. Or, jog through your tape by pressing and holding the button down.
- ◆ On-Screen Data button (DATA) turns the on-screen data in your viewfinder on and off. Works much like your "display" button on your camcorder.
- ◆ Auto Focus button (A) turns your focus control from autofocus to manual and back again (not available on all camera models)

VZ-Rock Similar to the StealthLX, the VZ-Rock has a precision-machined, industrial strength, all aluminum rocker and body (not plastic) which makes it more expensive to manufacture. Ideal for tripod use, the VZ-Rock utilizes a wide rear-mounted rocker that allows for a wide zoom 'swing' which enables you to easily control all zoom speeds in the camera. The VZ-Rock will allow full control over all zoom speeds of any camera it is connected. Great for small to large hands, allows for easy, friendly control over all functions. Also available for Panasonic DV camcorders



Same as StealthLX Except: Unique variable speed Rocker Zoom thumb control allows user to maintain the slowest crawl or gradually ramp up speed and then decrease speed gradually all in one smooth motion! Because your thumb never leaves the speed control you have quick response time and smooth actions to zoom in, zoom out, zoom faster or zoom slower. Simply push to the left of rocker to zoom out (wide) or to the right to zoom in (telephoto). No shaking the camera or time lost fumbling to find the right button to zoom in or zoom out.

CAMERA SUPPORT

STEADICAM JR

The 'Personal' Steadicam

The invention that won Academy and Emmy awards for technical achievement is available for your camcorder. Incorporating the same techniques for isolation, spreading camera mass and manipulating the center of gravity as the professional Steadicams, the JR works with small DV camcorders to yield images that are just as smooth and jitter-free. Produce smooth, hand-held moving shots with image steadiness never before achieved—even while walking, running or riding.

- ◆ Three-axis gimbal reduces rotary jarring. The gimbal, located at the top of the handle, is the most sophisticated engineering in the JR, intercepting unwanted rotation before it reaches the camera.
- ◆ Spreads the weight of the camera, increasing the resistance of the rig to unwanted tilt and roll and pulling the center of gravity into your hands
- ◆ Folding up the bottom arm and folding out a "Whale's Tail" (a small, "Y"-shaped piece of metal) converts it into a shoulder mount. If both arms are folded flat, the JR attaches to a tripod with standard screws. In all positions, the LCD monitor is still useable.
- ◆ With the larger rigs, taking a shot that needs a tripod means removing the camera from the Steadicam. The JR however, doesn't have to be removed to get those shots.
- ◆ Available with or without a specially treated 3.5" LCD monitor that minimize reflections, freeing your eyes from the camera viewfinder.



- ◆ Folds and stores in a layer 2" high beneath your camcorder. Weighs 2 lbs.

Steadicam JR (w/o LCD monitor)449.95

Steadicam JRM (with LCD monitor)699.95

Steadicam JRM Kit (includes Steadicam JRM, carrying case and "Obie Light")749.95

STICKY POD

Sticky Pod is a go anywhere, stick-to-almost-anything camera mount that can go over 110 MPH on the outside of a car and still take outstanding videos. The Sticky Pod can replace any tripod or monopod, and will stick to any car, truck, boat, plane or motorcycle. The industrial grade suction cups are soft, yet conform to almost any curved surface, and absorb much of the vibration, which makes for clear and stable video. There are no messy glues or residue. Simply push it onto a clean surface, tether and go. Not only can it stick to any glass, metal or plastic, but it works great on a fence, on a tree or on top of a rock. The base is constructed from a high grade heavy aluminum and the steel black camera base is fastened with steel rivets. Even the extensions and knuckles are solid aluminum. The camera mount knuckle rotates a full 360° and tilts side-to-side a total of 210°. A short tether is also included to secure your camera nearby.

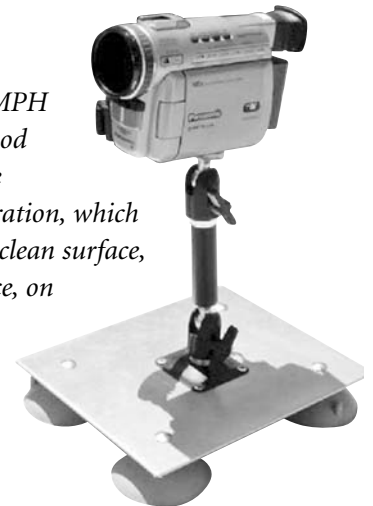

Original Sticky Pod

Heavy duty full throttle action. Video at just about any speed and be sure to apply plenty of G-loads because there's no stopping this one.

- ◆ Knuckle
- ◆ 3" Solid aluminum extension
- ◆ Short camera tether
- ◆ Rubber cushion for knuckle
- ◆ Computer video instructions

My Sticky Pod

- ◆ Same as Original Sticky Pod, but with a smaller triangular base

Sticky Pod Pro Pak

All the benefits of the Original and no compromises. This is the setup the pros are buying

- ◆ 2- Knuckles
- ◆ 3" Solid aluminum extension post
- ◆ 6" Solid aluminum extension post
- ◆ Long camera tether
- ◆ Short camera tether
- ◆ 2- Rubber cushions for knuckles
- ◆ Suction cup with mounting bolt
- ◆ Computer video instructions



ONE HOUR FREE PARKING

AT 349 W. 34th STREET (with purchase of \$100 or more)

GLIDECAM

2000 PRO / 4000 PRO

Camera Stabilization Systems

Imagine a world in balance. Imagine smoothness, freedom and grace. With the Glidecam 2000 PRO and 4000 Pro your camcorder floats, always balanced, isolated from your hand's undesirable motions. Now you are free to move with your camera – panning, tilting, booming or running – without any camera instability or shake. Lightweight, hand-held camcorder stabilizing systems they allow you to shoot incredibly smooth and graceful shots, even while running up and down stairs or traveling over rugged terrain. And when it comes to normal shooting, like walking or moving the camera slowly around someone, the results are equally magical. Shot after shot, move after move, they deliver beautifully smooth and professional results. No more need for a tripod or a Dolly — now all you need is your imagination!

- ◆ The 2000 Pro is 14" tall and supports any camcorder weighing up to 6 pounds. The 4000 Pro is 18" tall and supports any camcorder weighing from 4-10 pounds.
- ◆ Easy to set up and balance, they allow unrestricted booming and 360° panning.
- ◆ Offset handle grip is attached to a free-floating precision Gimbal, allowing hand movement up and down and side to side, thereby isolating unwanted hand interference from the camera. The up and down movement alleviates the bouncing pogo-type action associated with other systems whose handles can't move up and down.
- ◆ You can shoot upside-down, sideways, low near the ground, overhead and angled, as in a Dutch shot.
- ◆ The system's free floating, precision gimbal includes integrally shielded bearings, two of which are housed in the unique Offset Handlegrip. These precision bearings create the super-smooth and pivotable connection between your arm and the unit's Central Support Post.
- ◆ The counterweights on the Base Platform can be quickly attached or adjusted while the system is resting in an upright position on its base.
- ◆ The camera platform moves back and forth and side to side, allowing quick adjustment of your camera's horizontal balance. Camera's vertical balance is adjusted by varying the amount of counterweight disks on the base platform.
- ◆ Camera mounting platform (x-y motion table) measures 4" x 6" on the 2000 and 5.25" x 8" on the 4000. The 2000 has 1/4" mounting holes, the 4000 1/4" and 3/8" in the head plate for camera mounting.
- ◆ For remote viewing, an optional LCD monitor can be attached to the mounting holes on the base platform.

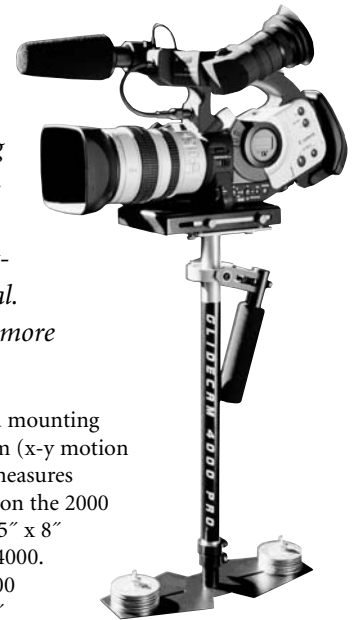

2000 PRO	299.95
4000 PRO	389.95

ACCESSORIES

149

GLIDECAM ACCESSORIES

Body-Pod

A lightweight rigid support system which when used with either the 2000 or 4000 Pro, allows all the weight of the system to be supported by your body, allowing you to shoot in cushioned comfort for indefinite periods of time. By taking the stabilizers weight out of your hands and arms and putting it on your waist and shoulders, stress and fatigue are virtually eliminated. The Body-Pod allows you to quickly slide the handle of either the 2000 or 4000 on and off its rigid support, so you can quickly switch back and forth between hand-held stabilization shooting and body mounted shooting. Since the support of the Body-Pod is rigid and for the most part inflexible, it will not absorb and smooth out camera movements as well as a stabilizer which is being held in just your hands. However, shooting with stabilizer attached to the Body-Pod will still yield results that are far better than unbalanced, hand-held shooting.

Body Pod169.95



Forearm Support Brace

Distribute the weight of the system over your entire forearm. The weight of the system is supported evenly by Glidecam's exclusive and unique, exoskeletal forearm support brace. The brace not only provides you with cushioned comfort while shooting, but also eliminates torque, which would otherwise cause stress on your wrist. With the forearm brace, the Glidecam system becomes an extension of the human body for smooth and natural shooting.

Forearm Support Brace149.95



ORDER & INFO. (212) 444-5010 • FAX: (212) 239-7770 (800) 947-7008
1-800-947-5525 • www.bhphotovideo.com



HOLLYWOOD LITE

VS-1

ACCESSORIES

150

Handheld Stabilizer for Camcorders up to 4 lbs.

With the VS-1 you can shoot video while walking, running, going up and down the stairs or travelling on uneven terrain. Whether shooting industrials, documentaries, commercials, weddings, news, or feature motion pictures, the VS-1 will bring the fluidity and grace you always wanted—elevating your footage to a whole new creative level. The most maneuverable and robust handheld stabilizer of its kind, the VS-1 is specially designed to bring an extra touch of magic to your DV camcorder (up to 4 lbs). Extremely affordable, the VS-1 will easily fit into your budget and quickly become one of your most valuable tools.

- ◆ The platform (stage) is precision-manufactured so you can quickly and easily adjust the side/side and the fore/aft.
- ◆ Unique base allows you to retract the legs, which in turn enables you to use it as a tripod.
- ◆ Patented gimbal allows you to rotate and tilt the VS-1 using just your finger tips.
- ◆ Systems are manufactured with the weights at the base for counter balance. You can add, adjust or remove depending on your needs. Extra weights are provided for convenience.



- ◆ Manufactured from aircraft aluminum, the VS-1 will last a lifetime.

Hollywood Lite Stabilizers are primarily designed to eliminate all unwanted motions as you're working with all types of moving shots. These professional stabilizers allow you to, walk, run, go up and down stairs and even travel on all uneven terrains. "Video Artists" can easily and affordably stabilize their videos while taking their footage to a whole new creative dimension. Whether you're shooting industrials, documentaries, commercials, weddings, news, or feature motion pictures, a Hollywood Lite system will bring the fluidity and grace you always wanted.

ULTRA-LITE

Handheld Stabilizer for Camcorders up to 7 lbs

With a higher weight capacity and longer upward or downward range than the VS-1, the Ultra-Lite is still easy-to-use, yet will capture those perfect video shots with ease and perfection. The Ultra-Lite is capable of comfortably holding any camcorder weighing up to 7 lbs. Yet you can hold it in your hand while walking and running and still get the smoothness you desire for your videos.



- ◆ Quickly and easily mount and dismount your camera using the Quick-release feature. The best part is, once you balance your camera, you'll never have to balance again!
- ◆ Expandable post allows you to adjust the weight capacity. (No tools necessary).
- ◆ Single-hand use Gimbal allows rotating and tilting in just about any direction and still gives a sense of floating. Rotating the camera to view your image is a lot smoother.
- ◆ Counter-balance is achieved by rotating the weight at the bottom of the system. The 6.5 ounce weight will allow you to balance the Ultra-Lite with the touch of a knob, allowing for side to side and for/aft movement.
- ◆ Light enough to carry, yet sturdy enough for a camera up to 7 lbs. Achieving your perfect video has never been easier in a hand-held system.



- ◆ No tools are required to assemble the Ultra-Lite. Screw in the expandable post to the lower strut, and do the same with the counter weight. Screw in the quick release plate onto your camera, and lock it onto the Ultra-Lite and you're all done



For Any Inquiries Regarding Your Order, Call Our Customer Service:
(800) 221-5743 • (212) 239-7765 • FAX: (800) 947-2215 • (212) 239-7549

HOLLYWOOD LITE

G.T. SERIES

Fully Supported Stabilizers with Vest, Arm and Monitor

These state-of-the-art stabilizers are the most solid and robust of it's kind. Made out of lightweight, T6 aluminum, all parts are machined to precise dimensions to ensure dynamic balance of the sled, fluid motion of the arm, and a snug fit of the vest. The dynamically balanced sled is fully adjustable and comes with a 5" TFT, color LCD monitor. It's easy tilt makes viewing more convenient. An expandable post and sliding gimbal gives you many configurations on the height you desire for you camera. With the G.T. Series, Hollywood Lite now offers the most affordable and versatile line of stabilizers in the world. This system comes with all the accessories you need to dramatically improve your video shoots.



ACCESSORIES

151

The Arm: The arm is a single articulated, double spring loaded. Depending on the weight of your camera, you can adjust the capacity with a thumb screw located on the front of the arm. All parts are black anodized. Has two chrome plated springs. Easy swing from left to right hand users. Interchangeable post link for different heights.

The Vest: This is the portion of the system that distributes the weight to the operators body and can be adjusted to fit a wide range of operators. It is comfortable, lightweight and fully padded (high endurance closed FVA padding and light weight aluminum). The vest distributes the weight evenly across your shoulders, back, and hips. Quick release buckles allows the vest to be removed in seconds.

The Sled: The Sled is the most important section of the balancing phase. The lower section (monitor and battery) are the counter weights from the stage and the your camera, separated with a free floating precision three axis gimbal. With the help of 6 precision bearings, you can tilt, rotate or swing your camera in any direction needed. This sub assembly can be moved up or down depending on the weight of your camera. The precision aluminium stage features fine tune side/side and fore/aft adjustments for horizontal balance, and 24" expandable post for vertical balance.

Complete System:

Every G.T. Series is completely enclosed in a Black Cordora case on wheels, with the following items: Padded vest, single articulated arm, dynamically balanced sled, 5" LCD, TFT monitor, battery, battery charger, video cable, allen wrench, dovetail plate, instruction manual, and an easy to follow video tap, and a 6 months warranty card.

The G.T. from 3 to 6 pound cameras, (VX1000, GL1, etc.).....**Call**

The G.T.X. from 6 to 11 pound cameras, (Canon XL-1, etc.).....**Call**

and the G.T.S. from 11 to 15 pound cameras. (JVC 500, etc.).....**Call**

The rechargeable 12v battery (included with system) powers the included 5" color LCD monitor for about 3 hours. For better balancing and to obtain dynamic balance, the battery can be moved in and out with a thumb screw which is located under the sled. NP-1 and Anton Bauer battery mounts are available.

LOW RIDER

The Low-Rider stabilizer is for the videographer who is striving for that low-to-the-ground video shot, especially on the moving things, such as snakes, reptiles or insects, animals or even crawling babies! Capture the beauty of flowers and foliage, or snow covered grass. Movement close to the ground has never been easier than this. You can follow those crawling creatures in motion while achieving the smoothness in your video at the same time.

You simply mount your camera inside the low-mode cage and hold onto the grip. The monitor gimbal on the top is also adjustable for easy viewing. All wires are hidden inside the post and can be easily changed or replaced if a larger monitor is needed. The Low-Rider is available with or without the 5" LCD monitor and battery.

- Accessories included with each G.T Series:**
- Dovetail plate to mount your camera onto.
- Lenmar battery and charger.
- Video cable, allen wrench, light stand post.
- This complete system comes in a black cordora suit case on wheels.

The optional Low Mode bracket allows you to shoot at ground level and still remain as stable as if you were on a moving tripod.

VELBON

VIDEOMATE 404/504/507/607

Lightweight and compact, the Videomate 404 and 504 feature a unique 3-way panhead ideal for use with compact Digital8 and DV camcorders. The Videomate 507 and 607 are more full-featured with a deluxe fluid panhead.

Videomate 404

- ◆ 3-way panhead (PH-349Q) features a sure-grip pan/tilt control handle positioned on the left side for more positive panhead control.
- ◆ The right-tilting camera platform offers vertical as well as horizontal composition.
- ◆ Geared center column with preset friction control system for quick and easy vertical camera or camcorder positioning.
- ◆ Panhead incorporates a large 2-position quick-release camera platform with retractable camcorder alignment pin.
- ◆ Quick side-lever leg locks for easy leg adjustments and non-slip rubber tipped feet.
- ◆ Radial leg braces for maximum stability and easy setup.

504 Step-up Features

- ◆ Leveling bubble for more precise tripod leveling.

V507 Step-up Features

- ◆ Deluxe 2-way fluid panhead is designed for fluid smooth pans and tilts. Position the sure-grip control handle in any one of four positions for maximum camcorder control.
- ◆ Panhead features an "Auto-Lock" system for the quick-release camera platform with retractable camcorder alignment pin.
- ◆ Steel ground spikes with adjustable rubber feet for no-slip setups

607 Step-up Features

- ◆ Deluxe 2-way fluid panhead incorporates separate pan and tilt tension knobs for smooth pans and tilts.



Videomate 404.....	33.95
Videomate 504.....	44.95
Videomate 507.....	59.95
Videomate 607.....	69.95

	Max. Height	Folded Length	Tubular Legs	Weight
Videomate 404	57"	21.6"	20mm	2.7 lbs.
Videomate 504	59.5"	22.8"	23mm	3.3 lbs.
Videomate 507	60.6"	24.4"	23mm	3.8 lbs.
Videomate 607	64.3"	26.5"	27mm	4.5 lbs.

DAVIS & SANFORD

ProVista Tripod with FM18 Fluid Head

The ProVista is a rugged tripod with all the key features that serious amateurs and working professionals demand. It's perfect for the classroom also. Metal-alloy construction stands up to the most demanding use, without being heavy or bulky. Plus, there's the FM18 fluid head and unbeatable Davis & Sanford 10-year warranty.

- ◆ Handles DV and all camcorders up to 25 lbs.
- ◆ FM18 fluid head ensures satin-smooth pan and tilt action
- ◆ 3-section tripod, double-strut top section for stability
- ◆ Geared 11" center post with 3/8-16 mounting stud
- ◆ Air-cushioned center post prevents rundown
- ◆ Rubber-sleeved metal leg locks; for fast setup, locks open/close with 1/2 twist
- ◆ Rubber/spike balljoint feet grab any surface
- ◆ Center brace with lock adds extra stability
- ◆ Includes padded carrying bag



- ◆ Minimum/Max Height: 31/64", 31" folded, weighs 7 lbs.
- ProVista Tripod/FM18 Fluid Head.....229.95



EQUIPMENT LEASING AVAILABLE

TILTALL/SACHTLER

VIDEO TRIPODS

Tiltall

Professional Tripods with 3-Way Pan-Head

Includes what is probably the most unique panhead ever designed. The multi-position panhead tilts 90° to the left, 45° to the right, 90° forward and 45° backward. The center post rotates a full 360°. The tripod is complemented with all metal locking knobs, pan handles and all terrain legs featuring both rubber and spiked feet. You also get the bonus of one leg that screw off and become a full length monopod. Available in black, silver and gold.



- ◆ 53"/60" maximum height (70" with center post extended)
- ◆ 20"/30" folded up • Weighs 3/6 lbs.

Tiltall Black.....	109.95
Tiltall Silver	99.95
Tiltall Gold.....	119.95
Tiltall JR Black.....	99.95
Tiltall JR Silver	89.95

IMPACT

Favorit III #820

- ◆ 3-section, 3-way fluid head with bubble level
- ◆ 23mm square channel legged tripod with radial leg braces, rubber spiked feet
- ◆ Geared elevator with friction; fast lever lock; center brace with lockable collar, spiked legs with rubber feet
- ◆ Tension adjustment locking geared center column with quick release camera platform
- ◆ Maximum height: 59", 23.5" folded, weighs 3.2 lbs.
- ◆ Covered with a 5-year warranty



\$54⁹⁵

Sachtler DV-1

Designed for today's small DV camcorders, the DV-1 system delivers complete flexibility, ease of operation and allows creativity without restrictions.

DV-1 Fluid Head features:

- ◆ Frictionless leak proof fluid damping with one level of drag, for perfect pictures while panning, without jerks and vibrations. Operates without friction from -40°F to +140°F
- ◆ Quick Release/Automatic Locking System for quick set up.
- ◆ Sliding camera mount and plate with a 3.5" sliding range, makes a fast balancing system and ensures perfect balance across the horizontal plane. Most importantly, once adjusted, the settings cannot be lost.
- ◆ Dynamic counterbalancing prevents the camera from inadvertently tipping, and ensures that it is positioned securely at any tilt angle.



- ◆ Vibrationless vertical / horizontal brakes
- ◆ Built-in leveling bubble

DA-75L Tripod features:

- ◆ Dural aluminum construction with 16mm tube diameter
- ◆ 75mm / 3" bowl base
- ◆ Single extension design
- ◆ Weighs 9.9 lbs.
- ◆ Maximum height of 54.3" (not including head)
- ◆ Supports up to 4.4 lbs.

DV-1 Aluminum Tripod System: DV-1 Fluid Head, DA-75L 1-Stage Tripod, On-Ground Spreader and Petrol PTB-3 Soft Bag**599.95**

BESCOR

MP-101

Motorized Pan Hand for Camcorders (up to 6 lb.)

Fastens between any tripod head and camcorder. Two motors allow independent smooth remote adjustment of vertical and horizontal panning motion. Auto Pan Mode, allows continuous horizontal panning motion.



- ◆ Switch selector for either a 30, 60 or 90° movement.
- ◆ Maximum horizontal angle ±90°, maximum vertical angle ±15°.
- ◆ Runs on 4 AA batteries or optional PS-260 AC power supply
- ◆ Panning speed adjustable via the supplied remote control.
- ◆ Measures 5.75 x 4.5 x 4" (WxHxD). Weighs 27 oz.

MP-101 Pan Hand**89.95**

ACCESSORIES

153

SLIK

VIDEO TRIPODS

U Series Tripods

Designed for use with today's lightweight camcorders, Slik's U Series combine modern design with ultra-smooth controls. They have a distinctive looking, dual-tone titanium finish with rounded contours and oversized leg locks for quick, responsive leveling adjustments. The fluid effect panheads assure you of professional looking videos without annoying jumps and jitters. They give you the necessary stability for consistent focusing and the sharpest video images.



U 6600

- ◆ 3-way video/photo fluid effect panhead with locking handle
- ◆ Oversize, single-action leg locks
- ◆ Extends to a comfortable 56.3"
- ◆ Rubber leg tips for non-skid stability indoors or outdoors
- ◆ Geared center column with tension adjustment
- ◆ Torsion resisting leg braces

U 8000

Same as the U 6600 Plus —

- ◆ Dual-purpose quick-release platform
- ◆ Extends to 59"
- ◆ Geared center column with tension adjustment and locking collar

U 9000

Same as the U 8000 Plus —

- ◆ Built-in bubble level
- ◆ Two-way rubber or spike leg tips for non-skid stability

LIBEC

LS-35 Video Tripod

Supplied with the H-35 fluid head, the LS-35 provides smooth pans and tilts, with no backlash or bumps, and rapid secure camera counterbalance, with -80° to +90° tilt angle.

Also includes the T-57 aluminum single-stage tripod, offering superb strength and stability, with precisely spaced fastening to prevent tripod pinching when closing system.



H-35 Fluid Head:

- 75mm claw ball
- Quick release plate • Weighs 11 lbs.

T-57 Tripod Legs

- Aluminum alloy construction • Single extension design
- Maximum height of 57.2" (not including head)
- Positive locking leg knob, for fast accurate setups stability, and comes complete with carrying case and shoulder strap.

SLIK TRIPODS

	U 6600	U 8000	U 9000	504QFII	505QF
Weight	2 lb. 7 oz.	3 lb. 5 oz.	3 lb. 8 oz.	5 lb. 11oz.	8 lb.
Maximum Height	56.3"	59"	59"	60.6"	64.5"
Minimum Height	21"	22"	22"	18.5"	20.5"
Center Column Extended	11"	12"	12"	10.4"	7"
Length Folded	22.9"	23.2"	23.2"	27.4"	29.5"
Leg Sections	3	3	3	3	3
Load Capacity	3 lb. 5 oz.	4 lb. 6 oz.	4 lb. 6 oz.	11 lb.	11 lb.
Catalog #	617060	617800	617900	615504	617505
Price	\$29.95	\$39.95	\$44.95	\$119.95	\$169.95



VIDEO TRIPODS

504QF II

Video tripod for use with compact and full-size camcorders

- ◆ Video panhead with extra long, adjustable control handle that provides ultra-smooth fluid effect
- ◆ Separate vertical control with locking knob permits tripod use with 35mm camera
- ◆ Professional, black anodized finish for years of use
- ◆ Omni-directional quick release with video indexing pin for instant camcorder mounting or removal
- ◆ "Lift-n-lock" center column for fast setups
- ◆ D-shaped closed leg extension design provides maximum strength with "Zero Twist"
- ◆ Rubber leg tips for traction outdoors and protection to surfaces when setup indoors
- ◆ Maximum height 60.6"



615-504.....119.95

505QF

- ◆ Ultra heavy-duty construction to handle the weight and size of both compact and full-size camcorders.
- ◆ Specially designed positive-action fluid head has separate pan and tilt control locks so you can follow the action and set up for a shot in an instant.
- ◆ Pan head handle adjusts for individual comfort and control.
- ◆ Built-in bubble level assures accurate balancing.
- ◆ Quick release camera shoe lets you set and remove your camcorder easily.
- ◆ Precise geared elevation control and center column tension control to compensate for different camera weights.
- ◆ Center leg braces which lock and tubular leg design provide maximum stability, while rubber leg tips add traction.
- ◆ Maximum height 64.5"



617-900.....169.95

E-Z POD JR

This unique tripod was specifically created to be compatible with today's popular, lightweight camcorders. Weighing just over a pound, it's deal for sports events and for travel. So compact when folded, just 20 1/4", you can take it anywhere. Ready to set up? The quick release, rubber padded platform is perfect for instant camera mounting and removal. Panheads adjust for desired tilt movement to let you keep up with the action. The sturdy, 5 section, rigid tubular leg extends to a full 63". And set up and fold down are made easy with self-aligning, single action, speed release locks. For comfort, there's a soft leather grip, and a convenient wrist strap.



617-200.....39.95

SLIM POD

Sturdy, tubular leg design with single-action speed release leg locks for maximum rigidity and fast set-up. Four leg sections give you true eye-level operation. An adjustable panhead provides vertical tilt and horizontal panning action.

618-724.....24.95

E-Z POD

With its retracting video indexing pin, rubberized quick release camera platform and unique floating height adjustment, the EZ-Pod gives you easy, precise, push button, eye-level camera height control, as well as fast mounting of your camcorder. Maximum operating height is 62 1/4", and it folds down to a compact 18 1/2". Additional features include an adjustable tilt movement and single-action, speed-release leg locks for fast set-up and fold-down.



- ◆ Modern design is both functional and aesthetically pleasing
- ◆ A unique anti-gravity adjustment system gives you easy, precise camera height setting.
- ◆ Designed for use with most camcorders, the E-Z Pod has a quick release, rubber padded platform for instant camera mounting and removing.
- ◆ When the four rigid tubular leg sections are fully extended, the maximum operating height is 62 1/4". EZ-Pod holds down to a compact 18 1/2".

617-400.....49.95

BOGEN/MANFROTTO

VIDEO TRIPODS

3405 Junior Tripod and Head

Lightweight and compact, this 4-section tripod provides a stable platform for rock steady shots. The legs are constructed of sturdy multifaceted tubular aluminum featuring quick acting twist lock adjustment. The shoulder of the tripod is made of cast aluminum to increase rigidity and the 12.5" center column is reversible for low angle shots. The integrated 3-way head is also made of cast aluminum and features a quick release plate. Pan and tilt movements are extremely smooth.



Now you can afford to support your camera in style. Designed with the needs of cameramen, industrial and educational film makers in mind, Bogen video tripods incorporate many features found only in equipment costing much more. They are truly professional performers that do not sacrifice innovative engineering or dependability for low cost. Now you can be confident knowing that every movement of your camcorder will be smooth, steady and shake-free.

3001N

Lightweight, compact and sturdy, this tripod is ideal for camcorders, especially when you're on the move. It features 4-position leg angle settings (26°, 45°, 75°, 87°) for ease of leveling. A low-angle adapter is built into the center column for ground level shots. A variable height, reversible center column with innovative three-faceted design eliminates column rotation. Adjustable 3-section telescopic legs come with sure grip wing knob locks for secure locking.

3001D

Same as 3001N plus speedy setup coupled with added security when it's quick-action, lever-type legs lock into position.

3001PRO

This tripod has an easily removed center column that can be used horizontally or vertically. The column converts to an arm in seconds, providing tabletop and overhead camera positions that are impossible with standard tripods. Also includes a built-in spirit level.

3011N

Lightweight, sturdy and portable, this up-to-date basic tripod is one of the easiest to handle. Offers a long reversible center column for extra high adjustment with an innovative three faceted design that eliminates the problem of column rotation. Also features a one position leg spread, and leg collars with double wing locking knob.

3021N

One of Bogen's most popular and versatile tripods, the 3021N is lightweight and portable enough to take in the field, yet strong enough for the latest generation of DV camcorders like the DCR-VX2100.

- ◆ Rapid action lever leg locks with just 45° movement
- ◆ Variable height, reversible center column with innovative three-faceted design that eliminates column rotation.
- ◆ Low-angle adapter for ground level shots
- ◆ 4-position leg angle settings (26°, 45°, 75°, 90°) allow you to go from 68.8" to only 3.1" from ground level
- ◆ Quick-action, lever-type leg locks for fast setup and added security

	3001N	3001D	3001PRO	3011N	3021N
Closed Length	20½"	20¼"	22"	24"	24"
Minimum Height	12¼"	6¼"	8¼"	22"	3.1"
Maximum Height	46½"	45¼"	46-3/4"	54"	51.9"
Max. Height with Ext. Center Column	53¼"	57"	57"	71"	68.8"
Weight	3.74 lb.	3.83 lb.	4.2 lb.	4.8 lb.	5 lb.
Maximum Load Capacity	11 lbs.	11 lb.	11 lb.	13.2 lb.	13.2 lb.
Spirit Level	—	—	Yes	—	—
Three-Faceted Center Column	Yes	Yes	Yes	Yes	Yes
Center Column as Horizontal Arm	—	—	Yes	—	—
Low-Angle Adapter	Yes	Yes	Yes	—	Yes
Leg Locks	Screw knob	Lever	Lever	Screw knob	Lever
Leg Angle Settings	4	4	4	4	4
Feet	rubber	rubber	rubber	rubber	rubber



BOGEN/MANFROTTO

VIDEO TRIPODS

3126

MICRO FLUID HEAD

The smooth movement of the 3126 Micro fluid head (only 2 1/4 lbs. including an adjustable handle) will amaze you. It is perfect for just about any of the new lightweight cameras. It pans a full 360° smoothly and can be tilted up or down 90°. Has pan and tilt locks, a continuous-ly adjustable positioning slot for best camera balance and is designed so that the handle can be on either the left or right side.

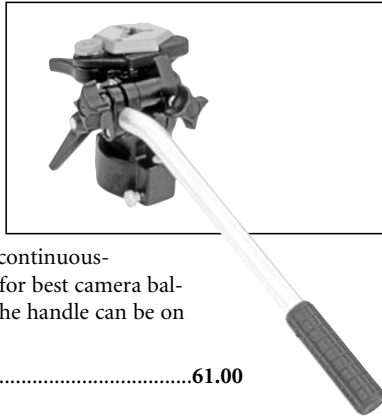

312661.00

700RC2

MINI VIDEO HEAD

The 700RC2 is a compact and lightweight 2-movement head designed to support the latest digital video equipment. The



700RC2 has a fixed length pan bar with a soft handle and separate locking mechanisms for 360° pan and +90°/-75° tilt. It comes equipped with a quick-release video plate system with VHS pin and secondary safety catch. Smooth and constant movements on both axis are assured by a fixed system of fluid cartridges with this video head.

700RC2 with RC2 Rapid Connect70.50

521

Basic Remote Control for Sony and Canon

Built onto a small clamp, the 521 controls Sony and Canon camcorder functions including Power On/Standby, Record/Stop, zoom and focus—via Control-L (LANC). The Zoom wheel direction can also be reversed. Easily mounts to a huge range of supports, such as pipes, bars, tubes, and flat surfaces. The 521 is supplied with a 9.8" coiled cord cable (extendable to 19.7").

522C LANC Camcorder Remote Control

Transfer the DV control to the panhandle and minimize the vibration associated with zooming in and out by hand with the 522C LANC Remote Control. This versatile command center puts the essential controls for most Mini DV cameras, such as focus, record, zoom, backlight, and fader, right at your fingertips. Now, you can operate both camera movement and recording controls with the same hand — without having to worry about how to reach the camera buttons, follow the subject, and keep movements smooth all at the same time.



Functions include switching between on and standby mode, starting and stopping recording, zooming (using a professional variable speed zoom wheel for finer control), manual focusing or switching to auto focus, accounting for backlit subjects, fading in or out and taking a still photograph. It has a LED power indicator and comes supplied with a 35" connecting cable. Fitted to a standard pan bar for quick and easy fitting to the 501. Also available with a pan bar and fitting suitable for the 700RC2 and 3130 video heads (522A)

3130

QR MICRO FLUID HEAD

This smooth action head is ideal for cameras up to 83/4 lbs. Includes an adjustable handle that can be positioned on either left or right, and it features a quick-release plate that allows you to change cameras or detach the camera with the flip of a lever. Pans 360°. Can be tilted up or down 90° and has Pan and Tilt locks.

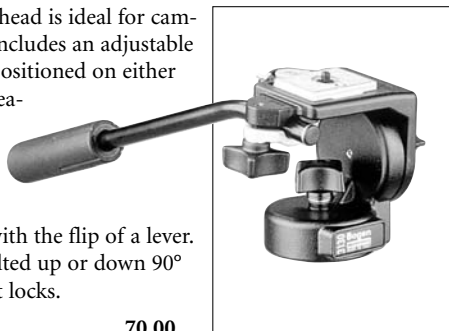

313070.00

3433

501 PRO VIDEO HEAD

Supporting payloads up to 13.2 lbs., the 501 offers the best price and performance for a head of this size. Light but positive fluid movement provides exceptionally smooth control through



360° Pan and +90 to -60° Tilt. It also has Teflon friction adjustment to increase drag, and separate Pan and Tilt locks. Pan bar can be located left or right, an optional second pan bar can also be used.

3433 (501)135.00

SONY

CAMCORDER MICROPHONES

ACCESSORIES

158

ECM-MS908C Stereo Camcorder Mic

Ideal for advanced amateur use, the stereo capability of the ECM-MS908C takes full advantage of the two-channel sound tracks on many of today's top Digital8 and DV camcorders.

- ◆ Video camera shoe attachment fits beautifully on most camcorders
- ◆ Extension arm holds the ECM-908C away from the camcorder body, reducing the transmission of mechanical noise
- ◆ Compact design for easy portability
- ◆ One-point stereo design -a single mic for stereo recording-is like having two microphones in one
- ◆ Oxygen-Free Copper (OFC) Litz cord for minimum loss, minimum noise
- ◆ L-shaped stereo mini-plug fits portable recorders
- ◆ Mid/Side (MS) capsules for natural stereo panorama; the mid capsule picks up monophonic sound while the side capsule picks up left/right difference sound; subtracting and adding the two capsule signals yield separate. Left and right channels-also permit electronic adjustment of pickup angle
- ◆ Mid/Side switch lets you select the "spread" between left and right channels by camera zoom, environment and shooting situations; choose 90° for close-ups and noisy environments; 120° for wide shots and quieter environments



- ◆ Gold-plated plug for maximum conductivity, minimum noise
- ◆ Triangular shape fits comfortably in the hand
- ◆ Supplied accessories include windscreen, microphone holder with camera shoe, extension arm and pouch

ECM-MS908C89.95

WCS-999

Wireless Mic System

Record voices up to 150' away depending on conditions.

Ideal for capturing family members

on vacation, at recitals, birthdays and weddings.



- ◆ Supplied lavalier mic is tiny and unobtrusive, clips onto shirt or tie
- ◆ Built-in windscreen reduces wind noise
- ◆ Electret condenser design for high quality and small size
- ◆ Omni-directional mic pattern picks up sound from all directions
- ◆ Pocket-sized wireless transmitter is easy to hide, clips onto clothing for unobtrusive use
- ◆ Three transmission channels enable you to choose another channel if you have interference
- ◆ Earphone to monitor what's being recorded

WCS-99999.95

ECM-S930C

Stereo Microphone

A high quality stereo mic with wide frequency response and dynamic range, the ECM-S930C is ideal for today's DV camcorders.



- ◆ One-point stereo pickup with separate capsules for left side and right side pickup, allows overlapping voices to be reproduced.
- ◆ Directional angle switch (90/120°) lets you change directivity characteristics according to the recording environment and source. 90° position when the source is a fixed location, 120° when sources are in a wide area.

- ◆ Ideal for recording parties, stage productions, business meetings
- ◆ OFC Litz mic cord and gold-plated plug for maximum conductivity, minimum noise
- ◆ L-Shaped stereo mini-plug allows for versatile connections

ECM-S930C109.95

ECM-Z37C Uni-Directional Microphone



- ◆ Super uni-directional pickup sharply focuses on sound directly in front of the microphone and eliminates extraneous sound.s
- ◆ Phase-Tube Noise Reduction System further reduces sound pickup from the side and rear to help avoid noise interference.

- ◆ Revolving shoe adaptor lets you change tapes, while keeping the mic on the camera
- ◆ OFC Litz mic cord and gold-plated plug for maximum conductivity, minimum noise
- ◆ 2-way power supply, supplied with pouch, extension arm and windscreen

ECM-Z37C109.95



EQUIPMENT LEASING AVAILABLE

CAMCORDER MICROPHONES

ECM-MS957

One-Point Stereo Mic

Incorporating a sensitive electret condenser mic, a rotating mid-capsule and Mid/Side switch, the ECM-MS957 is designed for high-quality instrument recording. Also ideal for use with field recorders, it also features a wide frequency response, superb dynamic range, and an XLR connector.



- ◆ Mid/Side (MS) capsules for natural stereo panorama; the Mid capsule picks up monophonic sound while the Side capsule picks up left/right difference sound; subtracting and adding the two capsule signals yield separate.
- ◆ The mid-capsule rotates to adjust the stereo pick-up pattern for the widest range of recording situations.
- ◆ Mid/Side (MS) switch selects pickup angle between left and right channel; choose 90° for a single voice or instrument or 120° to pick up many voices and instruments, arranged across the stage
- ◆ XLR connector for secure and reliable, low-noise connection
- ◆ Supplied accessories include detachable cable, stand, holder, windscreen and carrying case

ECM-MS957194.95

ECM-MSD1

Electret Condenser Microphone

A small stereo microphone that can be used on models equipped with external mic terminals. Offering dedicated audio mode selection featuring wide area pickup for



groups or narrow pick up for individuals, this mic is ideal for use during weddings, reunions and parties.

- ◆ Equipped with MS system for even more realistic sounds
- ◆ Super quality audio sensitivity
- ◆ User-selectable audio coverage: Select 90° for concentrating on a single speaker, or 120° for picking up ground conversation.

ECM-MSD179.95

ECM-T6

Tie-Clip Lavalier Mic

One-piece mic with clip makes recording inconspicuous and more natural. Lavalier design allows hands-free recording.



- ◆ Unique power On/Off switch
- ◆ 100 hour battery life with optional CR2025 lithium battery
- ◆ L-shaped mini-plug fits portable recorders

ECM-T614.95

ECM-C10/ECM-CS10/ECM-C115

Clip-Style Omni-Directional Mics

Clip style omni-directional microphones with integrated stand, these mics are ideal for recording meetings and lectures.



- ◆ Lavalier styling with supplied clip to attach to clothing; permits convenient, hands-free recording
 - ◆ Small, inconspicuous format makes the recording process more natural and less obtrusive
 - ◆ Omni-directional pattern picks up voices from all directions
 - ◆ Oxygen-free copper litz cord for minimal noise and signal loss
 - ◆ Gold-plated L-shaped mini-plug for maximum conductivity and minimum noise, fits portable recorders
 - ◆ 2-way power supply: plug-in power with select Sony portable recorders; battery power for use with all other recorders
- ECM-C10 Omni-directional mono microphoneCall
 ECM-CS10 Omni-directional stereo microphoneCall
 ECM-C115 Omni-directional mono microphone with windscreen.....Call

ECM-F01 Boundary Effect Mic

Compact and credit-card sized, the ECM-F01 has an omni-directional pick-up and flat design that makes it ideal for recording meetings and lectures in a conference or seminar room.



- ◆ Flat mic with Boundary Effect design enhances voice recording and reduces background noise when placed on a flat surface. Makes voices clearer than surrounding noise
- ◆ Credit-card size makes recording more natural and less obtrusive
- ◆ Mid-boost switch selectively makes the voice frequencies louder if the speaker far from the microphone
- ◆ Omni-directional pattern picks up voices from all directions

ECM-F0154.95

SONY/SHURE

LAVALIER MICROPHONES



SONY ECM-44B

Omni-directional Electret Condenser Lavalier Mic

The ECM-44B makes the exceptional quality of Sony's electret condenser mics available for budget conscious productions, and a variety of sound reinforcement requirements, such as lectures and demonstrations. Measuring 8.5 x 14.5mm, it delivers clean, bright, yet natural reproduction. Complete with in-line battery for 2-way powering (battery or 48v phantom power). Operates on a single AA battery for over 5000 hours. Supplied with urethane windscreen and clip.

SONY ECM-77B

Omni-directional Condenser Lavalier Microphone

At only 1/4" x 1/2", and a mere 0.04 oz. the ECM-77B is microscopic. Increased mechanical impedance using a metal vaporized, fine ceramic backplate provides exceptional 40Hz to 20 kHz frequency response. Combined with advanced techniques for sealing the capsule, it delivers sound that is audibly superior and more pleasing than any other lavalier mic. Ideal for TV broadcasting and stage applications where the mic must be inconspicuous, the ECM-77B enables unobtrusive miking and minimizes glare.



SHURE MX-183/184/185

Lavalier Microphones

Three wired lavalier microphones from Shure, no larger than a paper clip. Optional interchangeable mic cartridges let you tailor the microphones to any audio environment. The mics attach to the supplied power supply with the Shure Tini Q-G connector. When the power supply is removed, the mics can be used with any Shure wireless transmitters. Well suited for all levels of location video work, recording and live applications.

- ◆ Condenser lavalier microphones
- ◆ Frequency Response 60 - 20 kHz
- ◆ Includes both a pivoting single and dual microphone tie clip
- ◆ Black, snap-fit foam windscreen
- ◆ Interchangeable cartridges for omni-directional, cardioid and super-cardioid polar patterns

- ◆ Available with belt-clip phantom power only preamp and MX1BP battery/phantom power preamp
- ◆ Attached 4' cable with Tini Q-G connector



- MX183:**
Omni-directional condenser lavalier, belt-clip preamp, rotatable tie clip, dual tie clip, snap-fit windscreen.....**167.50**
- MX184:**
Super-cardioid version of above**186.50**
- MX185:**
Cardioid version of above**179.95**

- MX183BP:**
Omni-directional condenser lavalier microphone with 4' attached cable, MX1BP preamplifier.....**179.95**
- MX184BP:**
Super-cardioid version of above**194.95**
- MX185BP:**
Cardioid version of above**192.50**

SHURE SM93

Miniature Lavalier Mic

An economical, sub-miniature omni-directional lavalier condenser mic designed for use in speech applications. Despite its small size, the SM93 mic element provides full, clear sound comparable to much larger mics. Its smooth frequency response is specially tailored for chest-worn microphone operation, while controlled low-frequency rolloff reduces clothing and room noise. Runs on 11-52v DC phantom power.



- ◆ Ideal size for film/video/TV, theater, broadcasting and sound reinforcement
 - ◆ Preamp assembly with XLR connectors can be pocketed, strapped to the body, or clipped to belt or waistband
 - ◆ Supplied mounting hardware includes a sew-on mounting bracket, a mounting block with attached tie bar, and an acoustic windscreen to minimize wind noise
- SM93****146.50**



AUDIO TECHNICA

AT803B/AT831B/AT831R

Miniature Condenser Microphones

Designed to be worn on the clothing of performers, Audio-Technica's miniature condenser microphones provide excellent yet unobtrusive sound pickup. Their mic element is enclosed in a rugged housing with low-reflectance finish and internal construction minimizes handling and clothing noise. The wide-range capability of these mics ensure clean, accurate reproduction with high intelligibility for lecturers, singers, stage and TV performers, as well as musical instruments.



AT803b

Omnidirectional Condenser Microphone

The AT803b provides excellent yet unobtrusive sound pickup. The wide-range capability of the AT803b ensures clean, accurate reproduction with high intelligibility for lecturers, singers, stage and TV performers.

- ◆ Powered by AA battery (up to 1200 hours) or 9-52v phantom power
- ◆ 6' (1.8 m) cable is provided between the mic and power module
- ◆ A built-in 3-position switch on the power module allows selection of off, on/flat response, or on/low-roll-off
- ◆ Includes AT8417 clothing clip, AT8116 windscreen and carrying case

AT831b/AT831R

Cardioid Condenser Microphone

Cardioid versions of the AT803b, the miniature AT831b and AT831R (phantom power only) are designed for hands-free applications in sound reinforcement systems, and for use by musicians, especially for pickup of acoustic guitar. Cardioid pattern provides improved gain before feedback. Close-up voice and instrument pickup are crisp and clean, yet full sounding. Suppression of background noise is significantly better than that of full-size microphones. Same features and accessories as the AT803b plus they add the AT8444 guitar adapter.

AT899

Subminiature Omnidirectional Condenser Mic

Designed for high-quality, unobtrusive operation, the AT899 provides maximum intelligibility and clean, accurate reproduction for vocalists, lecturers, stage and television talent, and houses of worship.



- ◆ A mere 5mm in diameter the AT899 is ideal for applications requiring minimum visibility. The omni element is enclosed in a rugged, low-profile housing to minimize handling and wind noise.
- ◆ Supplied accessory kit includes single and double mounts, clothing clip, viper clip, magnetic clip, two open-pore foam windscreens, and two metal mesh element covers to protect the condenser element from moisture, makeup, and other contaminants. Also includes a convenient carrying case to hold the microphone and accessories.

AT899: Wired model with TA3F connection to the supplied AT8537 battery/phantom power module. The module features battery/phantom power operation, low-frequency roll-off switch, and an XLR3M connector supplying a low-impedance balanced output.....199.95

TRAM TR50

Lavalier Microphone



The TR50 is a miniature professional electret-condenser microphone designed to provide high sound quality with low, or even no-visibility. The tiny omni capsule features minimum sound coloration and is therefore easily combined with boom-mics during post production. A variety of accessories makes mounting the mic on or under clothing easy and reliable. The TR50 is available with the TR79 power supply for direct connection to a mixer, or with any of a large range of connectors for direct connection to virtually any wireless transmitter including Sennheiser, Lectrosonic and many more.

TR50 with XLR Connector

Includes Cable Holder (CH), Clip On Holder (COH), Tie Bar (TB), Windscreen (WS), Carrying Case (CC), Tape Down (TD), Tie Tack (TT).....294.95

AUDIO TECHNICA

AT815B

ACCESSORIES

162



Shotgun Condenser Microphone

The 18" AT815b is a wide-range condenser mic with a line + gradient polar pattern specifically designed to provide the narrow acceptance angle desirable for long distance sound pickup. Ideal for use in professional recording, broadcasting, film/ TV/video production, high-quality sound reinforcement and other demanding applications requiring excellent sound rejection from the sides and rear.

- ◆ Rugged housing with a low-reflectance matte satin nickel finish
- ◆ Powered by a single AA battery or 9-52v DC phantom power
- ◆ Recessed switch lets you choose either flat or a bass roll-off of 180 Hz at 12dB/octave
- ◆ Includes AA battery, foam windscreen, mic stand adapter with 5/8"-27 threads, and a compartment carrying case

AT897

Short Shotgun Condenser Microphone

The AT897 is a short condenser shotgun microphone. Unobtrusive length of 11" ensures that the microphone remains out of the frame when mounted on compact camcorders. The mic's narrow pick up pattern is desirable for capturing audio signals at long range. Excellent off-axis sound rejection minimizes noise and ambiance, emphasizing the desired signal. A wide frequency response provides accurate sound reproduction of signals registering at various frequencies. A low-cut frequency switch eliminates noise and hum registering at the low frequency range. Operates on a single AA battery or 11- 52v phantom power.

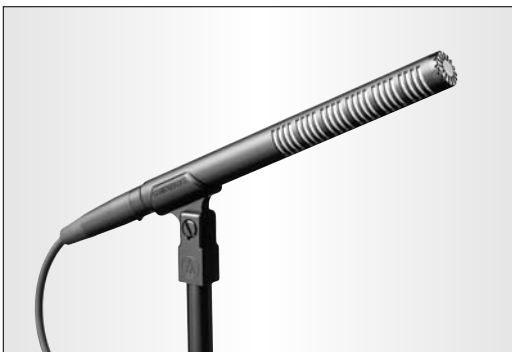

AT-4073a

Shotgun Condenser Microphone

The AT4073a is a transformerless line + gradient condenser microphone designed to meet the critical long-distance pickup demands of broadcasting, film/TV sound, professional recording and theater sound reinforcement. It features a broad-band, linear on-axis frequency response, with maximum rejection of sounds from their sides and the rear. It's lack of sound coloration on- and off-axis makes it particularly suited for miking dynamic action in film/TV audio as well as in "spot" miking techniques in the music studio or theater.

- ◆ Provides extremely high output and a noise floor that is hardly measurable, much less audible. Use it with confidence in distant miking applications and with digital recording systems.
- ◆ Exceptionally resistant to mechanical or handling noise. An integral 150 Hz hi-pass filter is available to "roll-off" the low-frequency response, thereby attenuating unwanted low-frequency ambient noise (such as air conditioning). The switch is recessed to prevent accidental activation. Powered with any remote "phantom" or "simplex" power source supplying from 11 to 52v DC.
- ◆ Through an advanced design, both the diaphragm and the side ports are exposed to the same acoustic environment. This makes it less sensitive to wind noise or the "encounter" noise of panning action. And there is a marked reduction in proximity effect. Recordings made at varying distances remain more consistent in response, making both production and editing quicker, easier and less costly.
- ◆ Sets a new standards in small size and light weight. Overall length is 9.13" and at 4 oz. adds practically no noticeable weight to the end of a fish pole or the top of a minicam.



For Any Inquiries Regarding Your Order, Call Our Customer Service:
(800) 221-5743 • (212) 239-7765 • FAX: (800) 947-2215 • (212) 239-7549

SGM-2X



\$219⁹⁵

Professional Shotgun Microphone

Designed for pro-sound and broadcast applications, the SGM-2X comes with two barrels, an omni (8.11" long) or, by adding the extension barrel, a supercardioid (15.75" long). Either configuration provides a sensitive (-50dB), low-noise, wide bandwidth signal (40Hz - 20kHz) through its balanced, low-impedance XLR output. Comes complete with an integrated shock-mount, both camera shoe-mount and mic stand-mount, and two foam windscreens.

- ◆ 2 barrels - an 8 1/4" omni and extension barrel - make it a 15 3/4" supercardioid
- ◆ Balanced low impedance (680 ohm) XLR output
- ◆ Integrated shockmount attaches to camera shoe or mic stand
- ◆ Plugs into the 41XT transmitter to make a wireless shotgun mic
- ◆ Switchable low-cut filter
- ◆ Runs 1000 hours on a single AAA battery

SGM-1X • SGM-X

Following up on the success of the SGM-2X, Azden offers two shorter versions—the SGM-1X and SGM-X—specifically designed for today's smaller DV camcorders.

- ◆ Ideal for the Canon GL-2, Sony DCR-VX2100 and other similar type camcorders, the 8.5" SGM-X is a complete system, including windscreen, shoe-mount holder and mini cable. Has a mini output.
- ◆ At 11.75" the SGM-1X is designed for camcorders like the Canon XL-1s and Sony PD-170. It features an XLR output and comes supplied with Azden's unique shockmount holder with integrated shoe mount.

SGM-1X.....149.95

SGM-X.....129.95



SONY ECM-672

Shotgun Microphone

Compact and lightweight, the 12" ECM-672 is a high-performance, electret condenser

supercardioid shotgun microphone designed for use on camcorders like the Sony DSR-PD170.

Tailor-made for ENG applications, it also offers versatility in applications such as interviews, sound reinforcement and speech. Superb controlled directivity assures rejection of ambient and camera noise, while the supplied windscreen reduces wind noise and provides pop protection during extra close miking.

- ◆ 2-position low-cut switch further contributes to the mic's low noise level and emphasizes desired sound sources by eliminating boominess in the low range.
- ◆ Powered by 12-48v DC power supply or via AA battery (up to 3000 hours of operation).
- ◆ Includes a windscreen



SANKEN CS-1

Short Shotgun Mic

Sharp directivity delivers targeted sound while eliminating background noise. Measuring only 7" in length,

the CS-1 is ideal for mounting on video and film cameras, and with a weight of only 3.5 ounces, it is also easy to maneuver on boom poles. Utilizing Sanken's original square condenser capsule, the CS-1 has a flat frequency response beyond 20 kHz and accepts sound levels up to 137 dB. Includes windscreen and case; shockmount is optional.



SENNHEISER

ME66/ME67

ACCESSORIES

164

Modular Electret Condenser Microphones

The ME66 and ME67 are modular condenser microphones that combine with the K6 power supply to bring a system of uncompromised studio quality sound and ruggedness to the broadcast and field recording markets. The K6 is the backend of the multimike system and accommodates a balanced, low impedance 3-pin XLR output connector. The modular design of the K6 power supply allows you to quickly convert from the ME66 and ME67 as well as four other microphone capsules simply by unscrewing the current capsule from the K6 and replacing it with another.

K6 Powering Module



The heart of the system, the K6 Module supplies power to any capsule in the series. It can run for 150 hours on a single AA battery, or can be used with 12 to 48v phantom power (AA battery doesn't drain while phantom-powering). The K6 features an on/off switch with LED battery status indicator; and a bass roll-off switch which will compensate for proximity effect in close miking, or for wind rumble in field recording.

K6 Series/K6 Series Pro Windscreens

Standard foam windscreens reduce wind and popping noise.

- MZW-66**
for ME-66, Grey **36.95**
- MZW-67**
for ME-67, Grey..... **42.95**

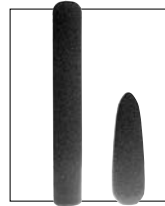

Black velour coated foam windscreens offer even greater protection for reducing wind and popping noise.

- MZW-66PRO**
for ME-66.....**64.95**
- MZW-67PRO**
for ME-67.....**96.50**

ME-66

Short Shotgun Capsule

The ME66 offers classic Sennheiser shotgun mic sound, extremely high sensitivity and very low-self-noise, resulting in unprecedented 'reach' characteristics for a mic that can be powered by AA batteries. Smooth frequency response (50Hz - 20kHz \pm 2.5 dB) provides for neutral, uncolored sound in the low- and mid-range frequencies and a gentle boost in high frequencies, for increased intelligibility. Great for interviews in crowded situations and as a camera microphone for ENG.



ME-67

Long Shotgun Capsule

The ME-67 is a long shotgun mic capsule whose extremely directional design brings distant sound sources into close range, with the extremely tight focus of the on-axis signal. As with the ME66, its frequency response (40Hz - 20kHz \pm 2.5 dB) is optimized for a natural presentation, with good articulation of high frequencies. High sensitivity and low self-noise, make the ME67 outstanding in difficult acoustic environments.



WINDTECH Shotgun Windscreens

High quality replacement windscreens for shotgun mics, they prevent unwanted wind, breath and pop noises. They also protect you microphone from dirt moisture and impact damage. Made from acoustical hypo-allergenic SonicFoam, they are washable, long lasting and keep their original shape.

- SG-1:** For mics up to a .75" diameter x 7.5" long (Audio Technica 4073a, Sennheiser ME66, MKH416).....**24.95**
- SG-2:** For mics up to a .75" diameter x 11.5" long (Audio Technica 4071a, Sennheiser ME67, ME80)**29.95**
- SG-60:** For mics up to a 1" diameter x 6" long (Sennheiser MKH60, Sony ECM-672)**24.95**
- SG-200:** For mics up to a .1" diameter x 4.75" long (most on-camera shotgun mics)**19.95**

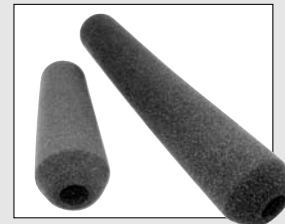

PSC Universal Shock Mounts



Designed to provide stable and noise-free handling for a wide variety of microphones, these shock mounts are constructed of lightweight aircraft aluminum and have a non-reflective black anodize finish. The two suspension bands are custom-made and provide a high degree of isolation from handling noise.

Used by ENG, film/video and TV sound recordists, change mics simply by pulling one out and pressing in another without fear of damaging the stock suspension assembly.

(Optional adapters allow installation inside Rycote Windshields). Available in 3" and 6" sizes, they accept mics up to 1.25" in diameter, while 3/8" x 16 threads allow use with any boompole.

- 3" USCM**.....**54.95**
- 6" USCM**.....**59.95**



EQUIPMENT LEASING AVAILABLE

MIC ACCESSORIES

RYCOTE

Mini Windjammers

Mini Windjammers are designed to improve the performance of camcorders with on board microphones and are to be positioned over a foam windscreen.



Medium Mini Windjammer: For mics up to 1.5" diameter x 2.5" length (GL-2, GY-DV300U) **48.00**

Special 90: For mics 2" diameter x 3.5" length (AT AT822/825, EV RE50)**50.00**

Special 60:
For mics 2" diameter x 2.75" length (DCR-VX2100)**50.00**

Special 130: For mics 2" diameter by 5" length (ECM-MS957, DSR-PD170)**55.00**

Special 155: For mics 2" diameter by 6.25" length (XL-1s)**55.00**

Softie Windshields



Windshield and shock mount with wind attenuation comparable to a standard Rycote windshield, Rycote's Softie windshields consist of an acoustic foam base covered with a specially designed synthetic fur. The shock mount has its own bracket and can be used as a pistol grip or boom mounted. Available in 12, 18, 24, 29 and 32cm lengths with three diameters to fit almost any mic.

Softie fronts, without the pistol grip and shock-mount, are also available for use with camera-mounted microphones.

Blimp System

Modular Suspension:

Lightweight suspension with a high precision modular frame. Includes pistol grip and boom adapter. Available in three sizes to fit a wide range of mics

Windshield (Requires Modular Suspension):

Lightweight and durable, the windshield provides up to 25dB exterior wind attenuation without unnecessary high frequency roll-off. Twist and turn locking end caps are rattle free and secure. Slide-on / slide-off system for easy removal of mic and suspension

Windjammers (Requires Windshield):

Specially designed materials with virtually no adverse effects on sound level or quality. Provides an extra 10 - 12dB protection over a standard windshield. Sizes available to fit all windshields



Multi Mount



A modified Softie Mount with a female 3/8" threaded brass insert suitable for stand and pole mounting. An integral accessory shoe allows for camera hot-shoe mounting. Isolates your camera-mounted mic from vibration.

LIGHTWAVE AUDIO

Miniscreens

Miniscreen: Fabric/mesh slip-on windscreens for film and video applications. The patented dead air space design with a small slip on screen provides superior wind protection over standard windscreens (20dB or more) and a sweetened mid-range that delivers enhanced dialog clarity.

Mini Windmaster: Deep pile 1" fur zipped cover for the miniscreen provides maximum wind blocking

MiniSock: Miniscreen zipped cover that affords high wind protection while maintaining sound transparency.



Equalizer



Low cost version of the Lightwave Miniscreen, the Equalizer features the same hollow shell interior and fabric mesh design and front and rear mic gripping disk system. The outer construction is made with a 25mm length ultra fine synthetic fur as is used to make the Miniscreen covers. Delivers excellent dialog recording in all ENG and EFP applications, with superlative wind protection - even under extreme wind conditions.

When purchasing either a Miniscreen (MS), Mini Windmaster (MWM), MiniSock (MSC) or Equalizer (EQ) just add the 3-digit code that references your microphone:

102 - for Canon XL-1s

104 - for Sony DSR-PD150, AT-4073

106 - for Azden SGM-1X, Sennheiser ME66, MKH-416, MKH-60

107 - for Azden SGM-2X, AT-835B

Minimounts

Minimounts are low profile and lightweight microphone mounts available for a variety of mounting applications. They hold any light to medium weight microphone in the 19mm to 30mm diameter range using a screw down arm clamp that allows fast changeover between mics. Isolation design allows the microphone float without 'flopping' around. Modular design allows the mic isolation assembly to be detached and adapted to any of the available lower section mounts.



Available Minimount Systems

MM-USC - Fitted with universal shoe carriage for camcorders with a hot shoe attachment.

MM-BSC - for mic boom. Fitted with swivel assembly carriage with 3/8" threaded base.

MM-XL - for the Canon XL-1 or Sony cameras with a round 27mm mic mount/clamp.

MM-25 - for use on camcorders that have 25mm diameter microphone clamps.

MM-PGC - with pistol grip handle for hand-held use

MICROPHONES

HANDHELD MICROPHONES

AT804 Omnidirectional Dynamic Mic

Designed for demanding sound pickup situations, Audio Technica's hardened-steel grille and die-cast case make the AT804 ideal for field applications where rugged construction is essential. Omnidirectional pattern picks up sound equally from all directions. So when close-up miking, the mic won't accentuate bass frequencies due to proximity effect. The omnidirectional pattern is also ideal for distant miking where the reproduction of ambient environments is desired.



- ◆ Rugged die-cast housing with a low-reflectance finish
- ◆ A protective hardened-steel screen reduces wind noise and plosives
- ◆ Internal shock mounting reduces handling and cable noise.
- ◆ Includes a snap-in stand adapter with 5/8"-27 threads and a soft protective pouch are included

EV 635A Dynamic Omnidirectional Mic

Probably the most popular and well-known ENG/EFP microphone in the world, the Electro-Voice 635A has survived being dropped, run over, thrown and even being shot while on location for film, TV and radio remotes. The 635A's uniform frequency response (80Hz-13kHz) is specially shaped for up-close vocals. Also available in black (635A/B) and with a Neodymium element (635ND-B).

635A • 635A/B

- ◆ Completely pop-free performance
- ◆ Four-stage pop and dust filter
- ◆ Internal effective shock absorber
- ◆ Includes stand adapter

635N/DB

- ◆ N/DYM element offers higher output
- ◆ Acoustalloy diaphragm material for very smooth response over a wide frequency range
- ◆ Integral windscreen and blast filter



EV RE50/B • RE50N/D Omnidirectional Dynamic Mics

Electro-Voice's RE50/B and RE50N/D are specially shock-isolated, omnidirectional, dynamic microphones created for the most exacting professional applications. Incorporating advanced shock-mounting techniques, they are designed particularly for hand-held broadcast and sound reinforcement use. Handling and clothing noise, even cord shock are isolated from the mic element so that mechanical induced noise is greatly reduced.

- ◆ No muddy lows when used near lips
- ◆ Acoustalloy diaphragm for very smooth response over a wide frequency range
- ◆ Dyna-Damp for extremely effective handling noise isolation
- ◆ Four-stage pop filter prevents dust from reaching the diaphragm
- ◆ RE50/B's attractive, non-reflecting, semi-gloss black finish is ideal for on-camera use
- ◆ Integral windscreen and blast filter for excellent protection from wind noise, excessive sibilance, and "popping"
- ◆ They include a stand adapter, vinyl carrying pouch and hard shell case

Sennheiser MD46 Handheld Dynamic ENG/EFP Microphone

Unlike omni mics that pick up everything equally, including background noise, the Sennheiser MD46 is a cardioid interview mic with studio quality that focuses on the subject, increasing clarity. In addition, Sennheiser put a double layer in the sound inlet basket to reduce the tendency for the mic to emphasize plosives, enabling the MD46 to highlight the desired sound (optional windscreen is still available though, if needed).

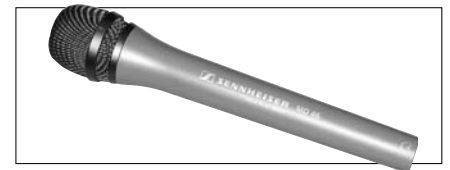

- ◆ Traditional long handle, wind attenuation and off-axis rejection
- ◆ With low handling and wind noise, and the ability to eliminate vocal popping, it is the ideal interview tool for ENG work.
- ◆ Extended high-frequency response of 40Hz-18 kHz, warm lows, and a clean midrange allows use in a pinch as an announcer or guest mic in remotes, studios or interview turrets.



ONE HOUR FREE PARKING
AT 349 W. 34th STREET (with purchase of \$100 or more)

MIC ACCESSORIES

BOOM POLES

Lightwave GT-10

5-Section High Grade Aluminum Boom Pole

- ◆ Easy to grip locking mechanism with a 1.5" long aluminum collar
 - ◆ Weighs 30 oz.
 - ◆ Minimum length 30", Maximum length: 9' 8"
 - ◆ Industry-standard 3/8" threaded tip
 - ◆ Powder coated soft-feel handle, and anodized tubing
 - ◆ High quality coil cable with matte black urethane insulation terminated by Neutrik gold pinned connectors
- GT-10 without mic cable.....155.00
GT-10C with internal coiled mic cable.....245.00



K-Tek Avalon KE-100

5-Section Carbon Fiber Boom Pole

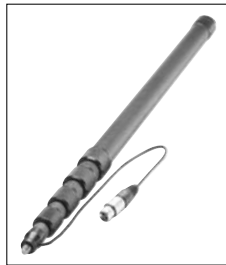

- ◆ Five section carbon fiber boom pole (uncabled) designed for ENG/EFP production
- ◆ Collapses to minimum length of 2' 2" and extends to a maximum length of 8' 9"
- ◆ Available internally wired with coiled cord (KE-100CC)

K-Tek K-102

5-Section Boom Pole

- ◆ Hybrid composite, high density graphite fiber selected for maximum strength and minimum weight.
 - ◆ Collapses to minimum length of 2' 2" and extends to a maximum length of 8' 9"
 - ◆ Ideal for ENG and documentary work.
 - ◆ Unique pole top with cable retaining slots and a replaceable stainless steel threaded mounting stud.
- K-102CC Factory wired with coil cord and female XLR (Bottom Connector)
K-102CCR Factory wired with coil cord and female XLR (Side Connector)
K-102FTS Factory wired with straight cable and male and female XLRs



Gitzo

Aluminum and Carbon Fiber Fish (Boom) Poles

Three carbon fiber and four aluminum microphone poles available in various lengths, designed for the location sound and audio recordist. The carbon poles use ultra lightweight, high modulus carbon fiber tubing that is very thin-walled without compromising their load capacity. The aluminum poles are made from stress-proof, high tempered aluminum alloys with black anodized finish. Telescopic extensions lock into place with a convenient twist-lock system, allowing simple and efficient setting of the required boom length. Complete with unique 1/4" - 3/8" reversible mounting screw, port hole for microphone cabling at both ends and soft rubber hand grip. Gitzo's commitment to fine European craftsmanship ensures smooth gliding movement with minimum bow when poles are fully extended.



ALUMINUM BOOM POLES

	Sections	Max. Ext	Min. Ext.	Weight	Max. Load	Price
G555	2	30.25"	55"	.75 lbs.	5 lbs.	74.00
G556	3	30.75"	79"	1 lb	1.0	87.00
G557	4	30.75"	103.75"	1.5 lbs.	1.5	120.00
G7680	6	31"	150"	2.25 lbs.	5 lbs.	188.50

CARBON FIBER BOOM POLES

G556C	3	83.4"	31.9"	0.79 lbs.	4.4 lbs.	149.95
G557C	4	108.2"	32.7"	1.15 lbs.	8.8 lbs.	179.95
G7680C	6	151.1"	33"	1.98 lbs.	4.4 lbs.	239.95

BOOM POLE ACCESSORIES

REMOTE AUDIO Universal Pistol Grip

Universal hand grip that adapts to any standard microphone suspension, the foam padded handle comes with a 3/8" threaded adapter (boom pole standard) and is also threaded at the base so it can attach it to a boom pole. Made from machined Delrin, stainless steel, and expanded polyurethane to provide significant additional shock isolation, it allows you to hand-hold a PSC mount, Audio-Technica AT8415 etc., with increased isolation.



BOOMMATE Boom Pole Holders

Boom pole holders attach to Avenger/Mathews grip heads and conveniently mount boom-poles to lighting or C-stands. This allows hands-free use of boom poles which are particularly useful in a single man operation or where microphone placement will remain stationary.

BOBPH.....64.95

GBBPH.....29.95

AZDEN

PRO SERIES

ACCESSORIES

168

VHF Wireless Mic Systems

The Azden Pro Series brings you high performance VHF wireless at a price you can afford. Built around a two-channel design that allows selection of the frequency that provides the cleanest signal — for reliable RF performance up to 250 feet away. They all feature two switchable frequencies — 169.445 and 170.245 MHz for a range of 250 feet, high performance VHF transmitters and receivers incorporating SMD (surface mount device) technology. The compact receivers connect to the camera's external mic jack with the attached mini cable and attach to the camera with a supplied shoe mount or Velcro, and have LED indicators for battery condition, transmit and receive operation.

COMPLETE SYSTEMS

WHX-PRO Handheld Mic System



- ◆ Completely self-contained VHF wireless handheld microphone/transmitter.
- ◆ Has two switchable frequencies for selecting the cleanest sound.
- ◆ Delivers crystal-clear sound at a range of more than 200 feet.
- ◆ On/off switch with standby position for quiet switching.
- ◆ Includes shoe mount and

Velcro for mounting the receiver to the camera, and an earphone for monitoring.

- ◆ Both microphone and receiver have LEDs for operating verification.

WHX-Pro.....149.95

WLX-PRO Lavalier Mic System



- ◆ Compact, lightweight, transmitter clips to subject's belt.
- ◆ Sensitive electret condenser lavalier mic with attached tie clip.
- ◆ Two switchable frequencies for selecting the cleanest sound.
- ◆ Delivers crystal-clear sound at a range of more than 200 feet.
- ◆ Receiver includes shoe

mount and Velcro for mounting to the camera, and an earphone for monitoring.

WLX-Pro.....134.95

CAM-3 Miniature Mic Mixer

This miniature 3-channel microphone-mixer allows you to add and mix sound from three microphone sources simultaneously.

Only 3¼ x 1¼ x 2¼", it weighs only 3 ounces, uses no batteries, and attaches to the camcorder or the hand strap



CAM-3 Mixer.....44.95

WMS-PRO Two Mic System

- ◆ Complete wireless mic system with two microphones (one lavalier, one handheld)
- ◆ Delivers crystal-clear sound at a range of more than 200 feet
- ◆ Two switchable frequencies for selecting the cleanest sound
- ◆ Miniature transmitter attaches to a belt or fits into a pocket
- ◆ Receiver includes belt-clip, Velcro, shoe mount for added versatility.



WMS-Pro.....143.95



AZDEN

PRO SERIES

COMPONENTS (RECEIVERS)

The incredible success of the "PRO" Series among videographers has prompted Azden to add 2 new frequencies, 171.105 and 171.845 to the most popular models, WR-22-PRO, and WDR-PRO receivers and the associated WL/T-PRO, WM/T-PRO, and the WX/T-PRO transmitters. These new frequencies will not interfere with Azden's long-established 169.445 and 170.245 MHz frequencies. (When ordering the new frequencies, specify "S" models.

WR22-PRO Discrete 2-Channel VHF Receiver

- ◆ Unique VHF receiver allows use of two wireless microphones simultaneously.
- ◆ Captures the voices of two people at the same time, with each on a separate channel.
- ◆ Each transmitter can be from 10 to more than 250 feet from the WR22-PRO receiver.
- ◆ Smaller than a pack of cigarettes, the WR22-PRO mounts on a camera with supplied shoe mount or Velcro.
- ◆ Operates on 9 volt battery and can be powered (with optional adapters) by 12 volt DC or 120 volt AC.



WR22-Pro154.95

WDR-PRO On-Camera True-Diversity Receiver

A VHF, true diversity receiver that incorporates two complete 2-channel receivers inside the case and two separate antennas to eliminate dropouts and help you create the highest quality audio. Both receivers are set to the same frequency, and the WDR-PRO's circuitry selects the receiver receiving the stronger signal from the microphone and accepts this signal. The LEDs on the WDR-PRO turn from red to green as one receiver, and then the other receives a stronger signal. Unlike the WR22-PRO, you can only use one microphone at a time.



- ◆ Diversity circuit avoids sudden dropouts and loss of signal.
- ◆ Compatible with all Azden "PRO" series microphones.
- ◆ Two selectable VHF frequencies.
- ◆ Range of over 300 feet.
- ◆ Attaches to your camera with supplied shoe mount or Velcro.
- ◆ Balanced output.
- ◆ 9-volt battery or 12-volt DC operation.

WDR-PRO169.95

COMPONENTS (TRANSMITTERS)

WM/T-PRO Handheld Mic/Transmitter

Same self-contained, handheld microphone as used in the WHX-PRO, it can also be used with WLX-PRO, WDR-PRO or WR22-PRO receivers.....104.95



WL/T-PRO Beltpack Transmitter

Same lapel microphone and beltpack transmitter as used in the WLX-PRO, it can also be used with WHX-PRO, WR22-PRO, or WDR-PRO receivers.....77.95

WX/T-PRO XLR Plug-in Wireless Transmitter

The WX/T-PRO converts any dynamic microphone with an XLR connector to wireless operation when combined with the WR-22 PRO or WDR-PRO receiver. Adjustable audio level accommodates a variety of microphones. Superb frequency response allow the true sound of your mic to come through. Power on/off, audio mute and status LED complete the full array of on-board controls needed for operational ease. It has a sleek ergonomic design in a durable ABS housing, and can operate for up to 10 hours on a single AA battery



WX/T-PRO119.95

AZDEN

100LT SYSTEM

ACCESSORIES

170

Event Series UHF Wireless Mic System

This system is the standard of price/performance for entry level on-camera UHF. Consisting of the 100UPR Receiver and the 10BT Transmitter, the Event Series 100LT system is small, lightweight and has 63 user-selectable (794-806MHz) crystal-controlled and PLL synthesized channels.

The 100UPR receiver features twin-antennas, a 3.5mm -58dB balanced mic level output jack, a 3.5mm monitor output jack (with level control), a recessed On/Off switch, a Power On/ Signal Received LED and channel selectors to set the desired frequency. Using crystal-control and PLL synthesis, the 100UPR operates for over 8 hours on a single 9v battery. CCwith mounting Velcro and a 3.5mm to 3.5mm output cable (Azden's MX-1 3.5mm - to - XLR cable is optional).

The 10BT body-pack transmitter comes with Azden's EX-503 omni-directional lapel mic and a metal belt-clip. In addition to the 3.5mm mic input jack, the transmitter has a Power On switch with an associated LED, a separate Standby switch for audio muting and a set of channel selector switches. Runs over 8 hours on a single 9v battery.



LECTROSONICS 100 SERIES

Camera Mountable Wideband UHF Synthesized Systems

Ideal for corporate and event videography, the Lectrosonics 100 System is designed for field production with compact DV camcorders or portable mixers. The system offers 256 selectable UHF frequencies to alleviate interference problems.

The tiny UCR100 receiver provides an adjustable output from -50dBv to 0dBv to match mic or line level requirements. Each transmitter offers a full 100mW of output power to deliver a fail-safe system with an exceptional operating range, free from dropouts. The audio processing includes the Lectrosonics exclusive dual-band compander, which lowers distortion and improves the signal to noise ratio over conventional companders. Machined aluminum housings, door and panel provides the ruggedness required to withstand the rigors of daily use.



UCR100 Receiver

- Output level control
- High sensitivity for extended range
- Unbalanced 1/8" output

UM100 Belt-pack Transmitter

- Over 30dB input limiting range
- TA5F 5-pin locking audio input
- Dual LEDs for accurate gain adjustment
- Variable low frequency roll-off
- Slim, spring-wire contoured belt clip

UHF400 Plug-on Transmitter

- 5, 15 and 48v phantom power
- DSP based pilot-tone signal isolator
- Digital hybrid synthesized UHF transmitter



AUDIO TECHNICA

U100 SERIES

UHF Multi-Channel Wireless Mic System

UHF camera mountable with a rock-solid RF design and rugged metal construction, the U100 system is available with either a body-pack or plug-on transmitter. Each system features the ATW-R100 true diversity receiver and operates in the channel 57 to 59 TV range avoiding upcoming DTV stations in the channel 67 to 69 range. The ATW-U101 system includes the ATW-T101 body-pack transmitter with standard Switchcraft TA5F input connector that is compatible with several lavalier and headworn mics. The ATW-U102 system includes the ATW-T102 XLR plug-on transmitter compatible with all dynamic and most self powered microphones.



ACCESSORIES

171

System Features:

- ◆ 100 Phase Lock Looped (PLL) -synthesized channels selectable via switches on receiver and transmitter
- ◆ Frequency-agility allows operation in both analog and DTV operating environments
- ◆ Operates in the less crowded 728.125 - 740.500 MHz UHF frequency band or TV channels 57-59
- ◆ 300' operating range typical
- ◆ 100 Hz to 15 kHz frequency response
- ◆ Hinged battery doors on receiver and transmitters

ATW-R100 Receiver

- ◆ True diversity operation automatically selects the better signal from two independent receivers, reducing dropouts
- ◆ LEDs indicate A or B antenna status, AF peak, and power status
- ◆ XLR balanced output with level control
- ◆ Removable antennas (BNC) connectors
- ◆ Operates on two internal 9 v batteries (for approx 6 hours) or on external 12 v DC
- ◆ Headphone jack with volume control
- ◆ Helical filter design improves rejection of unwanted signals
- ◆ Measures 3.35 x 4.53 x 1.42" (WHD) and weighs 12.0 oz.

ATW-T101 Beltpack Transmitter

- ◆ Features industry-standard Switchcraft 5-pin mic input connector
- ◆ Runs on a single 9V battery with approximately 8-10 hours battery life
- ◆ Measures 2.52 x 3.78 x 0.91" (WHD) and weighs 5 oz.

ATW-T102 Plug-on Transmitter

- ◆ 3-pin XLR-type input connector compatible with all dynamic and most self powered mics
- ◆ Runs on a single 9 volt battery with approximately 7-9 hours battery life
- ◆ Measure 1.57 x 4.32 x 1.57" (WHD) and weighs 6.2 oz.

U100 Wireless Systems

ATWU101

Includes ATW101 beltpack transmitter and ATW-R100 receiver (no mic)

ATWU101830

Includes ATW101 transmitter, AT831cT5 lavalier mic and ATW-R100 receiver

ATWU101831

Includes ATW101 transmitter, MT830cT5 lavalier mic and ATW-R100 receiver

ATWU102

Includes ATW102 plug-on transmitter and ATW-R100 receiver

U100 Components

ATWT101 Beltpack transmitter

ATWT102 Plug-on transmitter

ATW-R100 True Diversity receiver

AT831cT5

Miniature cardioid lavalier mic

MT830cT5

Subminiature omni-directional condenser lavalier mic

MT830cT5TH

"Theater" model (same as above except in beige)

ORDER & INFO. (212) 444-5010 • FAX: (212) 239-7770 (800) 947-7008
1-800-947-5525 • www.bhphotovideo.com



PR81/PT81

UHF Camera Mountable Lavalier System

Featuring the PR81 Receiver, PT81 Body Pack Transmitter and C417L Microphone, this UHF system is ideal for any lavalier miking application. A multi-channel system (up to 20 channels simultaneously), it features SAW (Surface Acoustic Wave) filters and 15 selectable frequencies to ensure interference-free operation. An intelligent battery management system monitors the transmitter battery voltage and computes residual capacity. A pilot tone system transmits battery data to the receiver and to control the Tone Code Squelch and Auto muting functions.

The PT81 bodypack's transmission characteristics include a 10 mW output and via signal companding, a dynamic range greater than 100 dB is attained at the receiver's output. Audio bandwidth extends from 50 Hz to 20 kHz. Through diversity reception, their performance is uniform over a wide range—up to 330'. Ideal for vocals, instruments and speech in theaters, conference centers, small sound systems, places of worship, and A/V productions.



FEATURES

PT 81 Bodypack Transmitter



- ◆ Miniature bodypack transmitter with rugged plastic case and mini XLR input
- ◆ Extended audio bandwidth makes them perfect for use with guitar and bass
- ◆ Works with AGK's C417/419/420/444L, CK77L, and MKG/L instrument cable
- ◆ 15 selectable carrier frequencies make it easy to set up multi-channel systems and avoid interference frequencies.
- ◆ Pilot tone for battery status data transmission
- ◆ Controls include frequency selector, on/off and mute switches, input level control, audio overload, battery status indicators
- ◆ Security covers for controls prevents unintentional readjustment.
- ◆ Uses one 1.5 V AA or rechargeable battery to keep operating costs low
- ◆ Intelligent battery management system computes transmitter battery capacity
- ◆ DC/DC converter maintains constant transmission quality throughout battery life

PR 81 Bodypack Receiver

The PR 81 UHF camera mount receiver offers unbeatable performance for the price. This portable miniature receiver with its rugged plastic case and mini-XLR output has been primarily designed for use in video and TV camera mount applications. However, the portable receiver can also be used as a distribution system for multiple language translations, in houses of worship, conferences and guided tours.

- ◆ Miniature bodypack receiver with rugged plastic case and mini XLR output
- ◆ 15 selectable carrier frequencies make it easy to set up multi-channel systems and avoid interference frequencies
- ◆ Microprocessor controlled "Four Level Diversity" antenna management system for reliable reception with no dropouts
- ◆ Clear status display including RF and audio levels, diversity, and mute indicators
- ◆ Fixed line level and adjustable headphones outputs on mini XLR connector
- ◆ Battery status indicator
- ◆ Volume control for headphones output
- ◆ Security covers protect the channel selector, squelch control, and on/off switch from unintentional readjustment
- ◆ Complete with versatile camera mount kit and belt clip
- ◆ An optional camera power adapter allows the receiver to be powered from the camera
- ◆ Uses AA alkaline or rechargeable batteries
- ◆ Designed for use with WWMS 81 handheld and body-pack transmitters

PR81/PT81 Lavalier System Includes:

- | | | |
|--------------------|--|-------------------------|
| ◆ Camera Mount Kit | ◆ Mini-XLR to XLR Audio Connecting Cable (Receiver Output to Camera Audio Input) | ◆ Miniature Screwdriver |
| ◆ Belt Clip | | ◆ Dry Batteries |
| ◆ Clothing Clip | | ◆ One Year Warranty |

SENNHEISER

EVOLUTION WIRELESS 100 G2

1,440-Channel UHF Wireless System

Simply the most affordable way to get professional-caliber UHF wireless, the amazing G2 Series offers four switchable presets (reprogrammable to any of the 1440 available frequencies) for even more flexibility a true diversity receiver for stable, high-quality transmission, and high-quality metal construction that can stand up to the rigors of life on the road. The bodypack transmitters and mobile receivers are 30% smaller than their predecessors and include a scan function that automatically searches for free channels, as well as an intuitive user menu and large backlit displays. A pilot tone squelch ensures that the transmitter microphone can be switched on and off without noise, The (adjustable) squelch can be deactivated in order to guarantee compatibility with the first evolution wireless generation. The bodypack transmitters and mobile receivers are powered by two AA-size cells to ensure a longer operating time and stable RF performance. In addition, a powerful rechargeable battery pack, the BA 2015, is now available for the hand-held transmitter, the bodypack transmitter, the plug-on transmitter and the mobile receiver.



ACCESSORIES

173

FEATURES

- ◆ System operates using switchable UHF frequency technology—previously available only on systems costing several thousand dollars. 1,440 digitally synthesized frequencies are instantly selectable in 25 kHz increments, so it's easy to pick a wireless channel that's free of interference.
- ◆ A choice of four preset frequencies saves you much time when operating several channels simultaneously on stage.
- ◆ A pilot tone squelch ensures that the transmitter microphone can be switched on and off without noise. The (adjustable) squelch can be deactivated in order to guarantee compatibility with the first evolution wireless generation.
- ◆ Unique HDX compander technology delivers crystal-clear sound. A noise suppression system, HDX compander optimizes the mic's dynamic range while minimizing unwanted modulation and transmission noise. The result is powerful, dynamic sound quality, equal to a good wired mic.
- ◆ Easy-to-read LED and LCD displays and user-friendly functions, with a logical approach to operations. Frequency, channels, sensitivity and other parameters can be viewed and adjusted in an instant. All components offer this same operating system.
- ◆ Automatic frequency scan feature searches for available frequencies
- ◆ User-friendly display on the mount receiver allows you to quickly read off all the important transmission parameters.
- ◆ Lock function avoids accidental changing of settings
- ◆ Mute function for the transmitter
- ◆ Designed to take hard knocks, transmitters and receiver are protected by a rugged metal housing
- ◆ High RF output power for absolutely reliable transmission and extended range
- ◆ Transmitters and receiver are powered by two AA batteries to ensure a longer operating time and stable RF performance. A rechargeable battery pack is also available.
- ◆ Low battery consumption allows longer performances, and all transmitters feature a flashing low battery warning LED.
- ◆ Wide range of accessories are available to adapt the system to any requirement

EW100-ENG G2 Kit:

Camera Mountable UHF Wireless Lavalier and Plug-on Bundle

The EW 100-ENG G2 system is ideal for video recording in the most varied recording situations. The ME 2 clip-on microphone is virtually invisible. The extremely small SK 100 G2 bodypack transmitter and the SKP 100 G2 plug-on transmitter as well as the EK 100 G2 camera receiver feature nine frequency banks with four directly accessible presets each – ready for immediate use.

System Includes:

- EK 100 G2 portable receiver
- SK 100 G2 bodypack transmitter
- ME 2 omni-directional clip-on mic
- SKP 100 G2 plug-on transmitter
- CL 1 jack cable
- CL 100 XLR cable
- Camera shoe adaptor
- 6 AA batteries

ORDER & INFO. (212) 444-5010 • FAX: (212) 239-7770 (800) 947-7008
1-800-947-5525 • www.bhphotovideo.com



SAMSON

SERIES ONE MICRO



UHF On-Camera Micro Diversity Wireless Microphone System

With a compact, lightweight, and streamlined design, Samson's UHF Series One Micro system is ideal for professional videography. It offers great performance along with a host of smart, practical features. Up to six systems can be used simultaneously. Designed for camera mounting, there are a wide variety of lavalier, handheld and headset microphones to suit any application from video deposition and wedding videography to corporate and broadcast video. The UM-1 Receiver features a balanced-XLR output.

FEATURES

UH-1 Handheld Transmitter



- ◆ Battery compartment conceals On/Off switch and an audio input trim pot, controlled with a supplied plastic screwdriver lets you optimize audio level performance when using different microphone elements
- ◆ 14-hour typical battery life and three multi-color LEDs indicate relative battery power (low, medium and high)
- ◆ External audio On/Off switch allows the audio signal to be muted without inducing a thud or popping sound when disabling the transmitter

UT1L Beltpack Transmitters

- ◆ A number of lavalier and headset microphones can be connected to the beltpack transmitters using a 3-pin Switchcraft mini-XLR jack
- ◆ Permanently attached pig tail antenna on the body-packs maximize RF transmission
- ◆ Beltpack transmitters have a belt clip that can be rotated to any desired position or removed

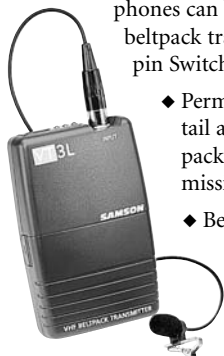

UM-1 On-Camera Receiver

- ◆ Houses two discrete receiver circuits while a processor decides which of the two receiver circuits has the better signal
- ◆ Offers 1/8" stereo headphone output with level control
- ◆ A/B LEDs indicate whether the left or the right receiver channel is currently in use
- ◆ 3 multi-color LEDs (low, medium and high) are switchable to indicate either battery power or RF signal strength and can be disabled to conserve battery power
- ◆ Peak LED indicator lights up red when approaching clipping which can cause audible distortion
- ◆ Battery compartment houses the on/off switch and a Variable Squelch control (with plastic screwdriver) that sets the maximum system range before drop out
- ◆ Both antenna mountings allow full rotation for flexibility in placement and can be folded inward for transporting
- ◆ Attaches to camera using supplied velcro
- ◆ DC input can accept voltage between 6-13v from a video camera
- ◆ Has a balanced-XLR output (as well as an unbalanced mini).Includes output cable
- ◆ Runs 12 hours on a single 9v battery

UM-1 Lavalier Systems

UT-1L Beltpack Transmitter, UM-1 Receiver, Balanced mini XLR-to-XLR output cable, Mic Clip and Carrying Case

UM-L350 With Audio Technica MT350.....	299.95
UM-L831 With Audio Technica AT831 lavalier mic.....	329.95
UM-L44 With Sony ECM-44 lavalier mic.....	369.95
UM-L77 With Sony ECM-77 lavalier mic.....	519.95

UM-1 Handheld Systems

UH-1 Handheld Transmitter with UM-1 Receiver, Balanced mini XLR-to-standard XLR Cable and Carrying Case

UM-HHQ With Samson QMic mic capsule	289.95
---	--------



EQUIPMENT LEASING AVAILABLE

SAMSON

MICRO 32



32-Channel UHF On-Camera Micro Diversity Wireless Mic Systems

UHF Micro 32 is a versatile frequency-selectable diversity system offering the highest level of performance for broadcast ENG/field work, corporate video and professional videographers. This remarkable system features 32 channels in both the receiver and transmitter. Sophisticated Diversity circuitry ensures optimum RF performance. The system features sophisticated SAW (Surface Acoustic Wave) filters in the receiver that focuses exclusively on the incoming signal to maximize reception and transmission quality. PLL-synthesized VCO circuitry in the transmitters reduces RF interference from spurious emissions in multi-user applications. The "system of choice" for demanding video professionals.

ACCESSORIES

175

FEATURES

System

- ◆ Three bands of operation (low, medium and high), with 32 different available channels per band, all operating UHF bandwidth. Up to six Micro 32 systems (each tuned to a different frequency within the same band) can be used in the same location without interference
- ◆ Uses SAW (Surface Acoustic Wave) filters like the one used in high-end television receivers for extremely precise and stable tuning. Ensures that the receiver focuses only on the incoming signal, not extraneous noise or overlapping signals.
- ◆ True Diversity technology maximizes active range (up to 300 feet) and reduces potential interference problems through automatic switching between two independent receivers
- ◆ Channel and group selectors
- ◆ Optimized for use in videography applications, the Micro 32 system is highly customizable, combining a UHF "walkaround" receiver with your choice of belt-pack or handheld microphone transmitters, as well as headset systems
- ◆ Built-in companding noise reduction in all components for crystal-clear sound with minimal background noise and hiss
- ◆ 3-year limited warranty

Transmitters

- ◆ Turning off the audio signal while leaving the carrier signal on, allows audio to be muted without "pop" or "thumps"
- ◆ Convenient three-segment multi-color battery strength LED meter for monitoring remaining power in the installed battery
- ◆ They run on 9-volt batteries for 8 hours
- ◆ Controls include Power On/Off switch, Audio Frequency Level adjustment, and Group/Channel selectors for 32 channels
- ◆ Compact "beeper-sized" belt-pack transmitter (4 ounces with a 9-volt battery installed)

T32 Systems

Including Transmitter, UM32 Receiver, Balanced mini XLR-to-XLR output cable, Mic Clip and Carrying Case



UM-32 Receiver with T32 Body Pack Transmitter and AT MT350 Lavalier Mic.....	349.95
UM-32 Receiver with T32 Body Pack Transmitter and AT MT831 Lavalier Mic.....	399.95
UM-32 Receiver with T32 Body Pack Transmitter and Sony ECM-44 Lavalier Mic	449.95
UM-32 Receiver with T32 Body Pack Transmitter and Sony ECM-77 Lavalier Mic	599.95
UM-32 Receiver with H32 Handheld Transmitter and Samson Q Mic Capsule	389.95

M32 Receiver

Includes a pair of tuned antennas and provides balanced and unbalanced outputs (with a three-position output level switch) and a headphone monitor output with adjustable level. Also includes an audio peak LED, dual receiver indicators, and an RF strength meter. Using the supplied velcro strip, the compact, lightweight M32 receiver easily attaches to any video camera.

ORDER & INFO. (212) 444-5010 • FAX: (212) 239-7770 (800) 947-7008
1-800-947-5525 • www.bhphotovideo.com



SONY

UWP SERIES

ACCESSORIES

176

Low-Cost UHF Synthesized Wireless Microphone System

Although low-cost wireless systems has proliferated dramatically in recent years, they usually lack in transmission stability and have noise problems that are overlooked. The ideal solution for budget-conscious users seeking rock-solid transmission, the UWP Series incorporates sophisticated wireless technologies from Sony's top-of-the-line UHF Series including PLL-synthesized system, space-diversity reception and a tone squelch function. Whether for low-cost ENG, EFP or PA systems, the UWP Series delivers the convenience of non-compromised wireless microphone operation at a very affordable price.

The UWP Series consists of five core elements — a lavalier/bodypack transmitter, a wireless handheld mic, a portable tuner, a half-rack-size tuner, and a tuner module. These are available in six turnkey packages, each comprising a microphone, transmitter and tuner, for a ready-to-go system straight out of the box. Each package has been carefully compiled to address almost any application—from video production and A/V presentations, to live performance and electronic news gathering.



FEATURES

- ◆ PLL Synthesized System used in the transmitters and tuners, achieves solid transmission and reception by using a stable carrier signal to avoid interference with other frequency channels and to allow the selection of a preferred channel from multiple frequencies (188 selectable frequencies).
- ◆ True Diversity Reception System—used in all UWP tuners – reduces signal dropout to a minimum. Achieves stable reception by using dual-antenna inputs/reception circuits that receive signals over two different paths and automatically select the stronger RF signal for output.
- ◆ The antennas of the portable and half-rack-size tuners each allow for angle adjustments, which helps to further eliminate signal dropout.
- ◆ Tone Squelch Circuitry prevents the output of unwanted signals or noise from other signal transmissions in the air, as well as the RF noise and popping noise that occur when the transmitter is powered on or off.
- ◆ Allows simultaneous operation of up to 16 wireless mics. Optimum combinations of practically tested, intermodulation-free frequencies (stored in the UWP tuners) simplifies the task of system setup.

Lavalier Microphone and Bodypack Transmitter

- ◆ Compact and light-weight design
- ◆ Includes belt clip
- ◆ 3.5mm, 3-pole mini-jack input connector with lock mechanism
- ◆ Supplied lavalier electret condenser mic with windscreen and mic clip



Bodypack and Handheld Transmitter Both Feature

- ◆ LCD screen displays the operating channel number and its frequency in MHz, attenuator level, RF-output level (High/Low), audio-input and RF-output status, transmitter-battery status and accumulated operating time
- ◆ Six hours operation on two AA batteries
- ◆ Selectable RF-output level: 5 mW for simultaneous multi-channel operation: 30 mW for long-distance transmission
- ◆ Attenuator function allows adjustment of the mic-input level to suit each user's voice

Handheld Microphone



- ◆ Uni-directional, dynamic mic capsule
- ◆ Internal antenna design
- ◆ Supplied with a microphone holder and a screw adapter



UWP SERIES

Portable Tuner (Receiver)

- ◆ LCD screen shows operating channel number and its frequency in MHz, audio-output status, RF-input level, tuner-battery status and operating time.
- ◆ Runs for six hours on two AA batteries
- ◆ Stereo mini jack with volume control
- ◆ Angle-adjustable antennas eliminate signal dropout and allow mounting position flexibility on a camcorder.
- ◆ Supplied shoe-mount adapter enables easy mounting on camcorders. Also includes mic stand adapter, screw adapter, mic cable and belt clip.
- ◆ Space diversity reception system for stable RF reception
- ◆ RF squelch function virtually eliminates ambient noise and unwanted signals from other wireless microphone systems



UWP-C1 Lavalier System

Suitable for a wide range of applications, from news gathering and interviews to talk shows and conferences. Includes a lavalier mic supplied with a windscreen and mic holder clip, a bodypack transmitter supplied with a belt clip, and a portable tuner

The tuner includes mic stand adapter, screw adapter, shoe-mount adapter for mounting on a camcorder and mic cable (3-pole mini plug/XLR-type)



UWP-C2 Handheld System

Suitable for news gathering and for use in PA systems. Consists of a handheld microphone supplied with mic holder and screw adapter and portable tuner

The tuner includes mic stand adapter, screw adapter, shoe-mount adapter for mounting on a camcorder and mic cable (3-pole mini plug/XLR-type)



BEACHTEK DXA-4

Dual XLR Adapter for DV Camcorders

The DXA-4 offers an easy, reliable way to hook up professional audio gear to your DV camcorder — and with it, all the benefits of using balanced audio for superb sound every time. Record from two sources at the same time. Each input is recorded on a separate audio track, making it possible for you to mix both channels during editing. You can even feed a time code signal into one input and audio into the other. Available for Sony DCR-VX2000/2100, TRV Series, Canon GL-1/GL-2 and XL-1/XL-1s.

- ◆ Two channels let you record two sources on separate tracks for post audio mixing. Both channels have their own mic/line level switch and trim potentiometers for flexibility and complete control
- ◆ Securely mounts underneath camcorder, eliminating cable strain
- ◆ Has a threaded hole for mounting on a tripod plate
- ◆ Rugged all metal case provides complete shielding from noise.
- ◆ Made with Neutrik XLR connectors and transformers for dependability

DXA-6: Now, an XLR adapter and phantom power unit in one compact device. Has all the great features of the DXA-4 with the addition of 48v phantom power on both channels. Works with any stereo camcorder.

SIGN VIDEO XLR-PRO

Passive Dual XLR Adapter/Mini Mixer

The XLR-Pro is a Dual XLR adapter that lets you feed professional audio to any camcorder that provides an audio 1/8" input jack. This allows you to use professional mics, tap into PA systems and mixers, and use long run, balanced audio cables — all with complete confidence. Special circuitry ensures that the XLR-Pro will work with any camera.

- ◆ Each of the inputs offer a choice of XLR and 1/8" mic/line switchable inputs with volume controls
- ◆ Connects to your camcorder via an 1/8" stereo mini plug with a 13" cable
- ◆ A stereo/mono output switch lets you record from one mic to both channels
- ◆ Securely mounts under your camera, for either hand held or tripod operation, or can be easily clipped onto your belt
- ◆ Unique ground switch lets you select the quietest ground for any camera
- ◆ 5.25 x 2.75 x 1.25" and weighs 13.5 oz.



FIELD MIXERS

AZDEN FMX-2

2-Channel Stereo Field Mixer



A portable, all-metal 2-channel low-noise field mixer, the ultra-compact (5 x 3.75 x 1.6" WxDxH) and lightweight (8 oz.)

FMX-2 runs on a single 9v

battery for up to 12 hours making it almost a requirement for any videographer's camera bag.

- ◆ Two balanced XLR mic/line switchable outputs plus a stereo mini-jack output for high-quality DV cameras.
- ◆ One mic can be mixed to both outputs as well as either single output while two mics can be mixed to either single output or mixed together to both outputs.
- ◆ Two balanced XLR inputs with individual level controls
- ◆ Twin "Peak" level input indicators, "Monitor" output (stereo or mono) with level control and a Power On/Off/Low Battery LED indicator.
- ◆ Can be attached directly to a camera with provided velcro or belt-worn using the included 3-position belt clip

WENDT X2

2-Channel Stereo Field Mixer



Ideal for audio mixing for film, documentaries, ENG or virtually any application requiring a portable mixer, the X2 features a compact and lightweight, but durable body

built to withstand the rigors of road use.

- ◆ Dual XLR balanced mic inputs delivering high audio levels while minimizing noise, and dual XLR balanced outputs that are switchable between microphone and line level output signal.
- ◆ Each channel features individually switchable phantom power, capable of sending 48V or 12T power to condenser microphones.
- ◆ Mic inputs also feature 0dB, 10dB and 20dB attenuation and gain switches, allowing further control over condenser microphones with high gain and dynamic microphones that require more.
- ◆ An additional stereo, 3.5mm mini jack output jack provides a secondary mic level output feed to camcorders, portable recorders, etc.
- ◆ The X2 is powered via 6 AA alkaline batteries for up to a 12 hours.
- ◆ Built in Slate Microphone and Test Tone Oscillator provides all the tools needed for meter and tape calibration.

SOUND DEVICES MixPRE

2-Channel Compact Field Mixer



Designed for remote or field mixing in video, film, broadcast or professional recording applications, the compact and lightweight

MixPre boasts an impressive feature set starting with 2 transformer balanced

XLR microphone inputs and stereo (L/R) XLR outputs. Separate stereo tape output and tape return input are provided, both feature 1/8" (3.5mm) mini stereo jacks.

- ◆ Mic inputs with L/C/R panning, 48v or 15v phantom power, 6dB per octave HPF @ 80 or 160 Hz and sunlight-readable LED meters
- ◆ Maximum of 66 dB of gain per input
- ◆ "Unclippable" input peak limiters with adjustable limiter threshold (per input) and dual mono or linked stereo limiter operation
- ◆ High-power headphone monitoring
- ◆ Operates on two AA batteries or external 5 to 17v DC powering
- ◆ High-strength, extruded aluminum chassis with protective metal end panels
- ◆ All-metal connectors solidly connected to chassis

SOUND DEVICES 302

3-Channel Compact Field Mixer

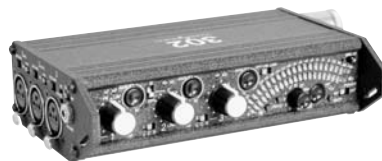

The 302 is a compact, professional audio mixer designed to meet the demands of film, ENG / EFP and broadcast

applications. It has three transformer-

balanced mic or line level XLR inputs with continuously adjustable input trim, L/C/R panning 2-position HPF, and phantom power (48V or 12V) or "T" powering per channel

- ◆ Stereo (L/R) balanced XLR outputs (mic or line level switchable)
- ◆ Limiters on inputs and outputs
- ◆ Solo (PFL) channel monitoring, sunlight-viewable LED meters
- ◆ Active-balanced line/tape/mic level outputs on XLR connectors; tape level output on TA3 locking connectors
- ◆ Return input for monitoring
- ◆ Powered by three AA batteries or external 5-18 v DC
- ◆ Sunlight-viewable LED meters with software selected ballistics
- ◆ On-board MS stereo matrix
- ◆ Push pots for setup features to keep the front panel clutter-free



FIELD MIXERS

SHURE FP24

Portable 2-Channel Stereo Preamp and Mixer

The FP-24 is a studio-quality, two-channel, portable stereo mic mixer, designed for active use in demanding broadcast environments. Features like assignable L-C-R inputs, built-in slate microphone, 1kHz tone oscillator, and headphone monitoring combined with compact and rugged mechanical and electrical construction, make this mixer ideal for any application.

- ◆ Two transformer-balanced microphone inputs with left, center, and right position mixing capabilities
- ◆ Unique 7-segment peak output meters, with three selectable levels of LED brightness—readable even in direct sunlight
- ◆ High current balanced output drivers provide signal integrity over long cable runs
- ◆ Headphone preamplifier enables monitoring of program audio or external tape return
- ◆ “Unclippable” input peak limiters with adjustable threshold (each input)
- ◆ Selectable 15v and 48v phantom power
- ◆ Switchable low-cut filters with 80 and 160 Hz corner frequencies, 6dB per octave



- ◆ Powered with two AA alkaline batteries for 11-12 hours) or 4-14v DC power (PS20)

PSC (Professional Sound Corporation)

DV PROMIX 3 3-Channel DV Mixer



Designed for today's demanding video shoots, the DV PROMIX 3 is a portable, battery-operated, robust three-channel mixer that provides very high quality audio in a compact, lightweight package.

- ◆ Accepts line level and dynamic mic signals and 48v condenser mics.
- ◆ Each input has a switchable low cut filter to reduce wind noise and is equipped with a channel assignment switch.
- ◆ Inputs and outputs are line or microphone level switchable
- ◆ Output limiters ensure you won't overload the cameras audio inputs, while the tape return function gives you confidence that the audio has been fed to the camera.
- ◆ Operates on two 9v alkaline batteries.

M3 3-Channel ENG Audio Mixer

A cost effective, flexible portable mixer that combines rugged construction, high quality componentry, and ease of use in a compact package, the M3 is perfect for ENG and EFP applications, digital and desktop recording and editing.



- ◆ Three transformer-balanced XLR inputs (with switchable “T”, Dynamic or 48v phantom powering) and outputs for pristine audio. Inputs and outputs are mic/line switchable and have a 3-way input pad: Dynamic 0dB Pad, Condenser -15dB Pad, and Line Level -50dB Pad.
- ◆ Includes two 10-pin connectors for use with Beta snake cables (mic or line switchable) to connect two cameras, and two Auxiliary outputs for RF feeds (mic or line switchable). Also provides audio signal and tape return signal flow for monitoring.
- ◆ Ganging input and output connectors let you use two M3 mixers tied together.
- ◆ Channels 3 and 4 can be linked for stereo recording using 2 mics in either M-S or X-Y configurations. The “Gang” switch links inputs 3 and 4 and both input levels are then controlled by Pot 4.
- ◆ “Separate” and “Ganged” switches allow independent or linked operation of both limiters.
- ◆ LCD peak meters emulate the peak reading attributes found in Betacam cameras. This ensures meters accuracy no matter how the mixer and camera are connected.
- ◆ Low cut filters eliminate low frequency noise and rumble.
- ◆ Built in slate microphone for recording notes and information related to editing.
- ◆ Headphone monitoring selections include Stereo, left or right to both ears, Mono, Pre Fade Listen of channels 1,2 and 3 and MS Stereo, and tape returns from two cameras.
- ◆ A handy boom-pole remote control attaches to any boom pole. This allows sound engineers to adjust recording level without reaching for the mixer.

FIELD MIXERS

ROLLS MX-124 ProMix IV 4-Channel Stereo Mixer

The MX124 is a lightweight, compact, four channel mic mixer featuring 3-pin XLR inputs and transformer balanced XLR stereo (L/R) outputs. Located on the side are four 18v DC phantom power switches and four low-cut filter switches. Individually switchable phantom power supplies allows the flexibility to use dynamic and condenser mics simultaneously and low-cut filter switches eliminate hum, rumble and noise associated with wind and proximity effect.



- The front panel has level and pan controls for each channel.
- 1/4" TRS phone and 1/8" (3.5mm) mini outputs can be used to feed headphones or as alternative stereo outputs.
- Runs on two 9v batteries for complete portability

ROLLS MX-442 4-Channel Field Mixer

A price/performance breakthrough, the MX-442 features four XLR balanced inputs with 48v phantom power, trim controls, 20 dB pad and Lo-Cut switches. Each input has trim and volume controls, and a pan control for adjusting the signal placement in the stereo field. Large VU level meters may be switched to monitor the R/L channel outputs (mono/stereo), monitor signal, or battery condition. It has two oscillators, one 20Hz tone with the Slate Mic, and a 400Hz tone for sound check and setup. An internally adjustable limiter with adjustable threshold is also included. The MX-442 is powered via 12v DC or by two 9v batteries (for up to 20 hours) and is housed in a lightweight aluminum chassis.



- 1/4" stereo headphone output with level control
- Battery test switch and indication on meters

VERSA-FLEX Professional Audio Harness

Carry your portable mixer or recorder with greater ease, comfort and accessibility using this over the shoulder harness. Room for mixer/recorder with additional clips for carrying extra equipment and cables. Wide shoulder pads provides better weight distribution. Weather proof durable construction. Compatible Porta-Brace, Kata, Petrol cases.



REMOTE AUDIO HN-7506 High Noise Environment Headset Monitor

Uses Sony MDR-7506 drivers with special baffling to provide extreme isolation from high noise environments such as helicopters, raceways, rock concerts, etc. Also adds a high degree of protection from hearing damage while giving the user the familiar sound of the industry standard Sony headphones.



PSC ALPHAMix 4-Channel ENG Mixer

AlphaMix offers four switchable mic/line inputs, 12T or 48v phantom power, low noise pre-amps with continuously variable gain trims, active low cut filters, balanced line level outputs per input channel, pre-fader-listens and simple three LED meters per input channel.



It uses NP-1 style batteries and is equipped with selectable low battery monitoring. In addition, it has four Hirose 4-pin power output connectors that allow it to power up to four wireless receivers. And unlike other external battery distribution boxes, each of the power outputs is individually filtered for quiet wireless operation.

The AlphaMix can feed and monitor audio returns from two cameras. It utilizes a custom-made peak reading LCD meter that emulates most of today's cameras. For further convenience, it has a boom pole mounted remote control that can be used to control the gain of the first input channel, thus allowing you to boom with both hands.

SOUND DEVICES 442 4-Channel Field Mixer

Designed for film, TV news, documentary, radio, effects recording, and music production,



the 442 sets new standards for functionality, size, and performance for portable audio mixers. It features 4 balanced XLR mic/line switchable inputs with variable input trim, pan and HPF; selectable 48v or 15v phantom or "12T" microphone powering per channel.

- ◆ Balanced line/tape/mic level output on XLR connectors and Hirose connector
- ◆ Peak limiters per channel, PFL monitoring in headphones
- ◆ On-board MS stereo matrix, Sunlight-viewable LED meters
- ◆ Direct outputs and balanced line or tape level output on TA3 locking connectors
- ◆ 1/8" stereo tape level and 1/8" mono mic level outputs
- ◆ 2 return inputs for monitoring two-camera productions
- ◆ Push pots for setup features to keep the front panel clutter-free
- ◆ Powered by 4 AA batteries or external 5 - 18 v DC



For Any Inquiries Regarding Your Order, Call Our Customer Service:
(800) 221-5743 • (212) 239-7765 • FAX: (800) 947-2215 • (212) 239-7549

MARANTZ

FIELD RECORDERS

PMD-101/201/221/222/430

Portable Cassette Recorders

The world standard for field recording, the PMD line is also the value leader. They all feature RCA line input/outputs, 1/4" headphone jack, built-in speaker, pause control, audible cue and review, tape counter, full auto shut-off and low battery indicator. Used professionally by journalists, law enforcement agencies, aural historians and musicians.



- ◆ Record limiter and Automatic Level Control (ALC) are great in news gathering. Connect a mic, press record, and get the story while the recorder takes care of levels.
- ◆ They run up to 7½ hours on three 'D' cell batteries, or up to 5½ hours with the optional RB430 rechargeable battery.
- ◆ Built-in electret condenser microphone is a great back-up in a pinch
- ◆ Modular telephone jack lets you record phone interviews and gives you the ability to play back over a telephone line as well.
- ◆ Mic attenuation is adjustable in three settings from 0 to -20dB
- ◆ 3-position noise control switch, (flat, low-cut, or low-and-high cut.
- ◆ All except the PMD-430 have 1/2 speed playback/record capability. 1/2 speed recording is great for churches, because 90 minutes can be recorded on a single side—no interrupting your recording to flip the tape over. Line inputs make it easy to use and connect to your existing sound system.

PMD-670

CompactFlash Recorder

The PMD-670 is a rugged and reliable digital portable audio recorder that records digital audio data directly to a single CompactFlash memory card. Ideal for in-the-field recordings. The ability to archive to various formats allows this unit to interface with a variety of equipment, be it analog, digital or a PC based system.



- Unbalanced RCA inputs/outputs along with a pair of XLR mic/line inputs are complimented by a S/PDIF I/O on RCA coaxial connectors.
- A switchable band or high-pass filter helps reduce ambient noise.
- Comes with a two-second pre-record buffer, a silent skip mode and has a built in microphone and speaker.
- Records to compact flash media that is immune to shocks and large temperature fluctuations
- Manual record with limiter or auto record level control

CDR-300

Portable Desktop CD Recorder

Designed for stand-alone portable recording, the CDR-300 is a professional CD recorder that offers the functionality of a professional tape recorder—while recording directly to blank CD-R/RW media.



Once finalized, recorded discs will play back in virtually any CD player.

To record, simply place the compact and lightweight CDR300 on a table-top, power it up via 120v AC or 12v DC power and record live using either the internal mic or external microphones that attach to stereo XLR or 1/4" mic/line inputs.

Because it has a built-in preamp, an external mixer or mic preamp is not required. A built-in speaker or headphone jack conveniently allows recordings to be monitored. High and low EQ and high and band pass filtering can be independently adjusted for each mic/line input in the preset menu. 48v phantom power is available for condenser microphones. The CDR-300 also provides manual or automatic level control, limiter, and digital level meters.

FOSTEX FR-2

CompactFlash Recorder

Designed specifically for location sound recording, broadcast and sound effects acquisition, TV and radio docu-



mentary, and in fact any application where high quality audio recording is required, the Fostex FR-2 sets a new price performance ratio in the compact portable two track recorder market.

Flexibility is the keyword with the FR-2. Recording industry-standard Broadcast Wav Files (BWF) to either PCMCIA 1.8" hard drives or Type II Compact Flash cards, the FR-2 brings many features from Fostex's experience as a long-term leader in digital location recording such as a 10 second pre-record buffer, battery power, on-board limiter, and phantom powered balanced mic inputs. Of particular note is the file per take system with scene and auto take naming which was developed on the industry acclaimed PD-6 & DV40.

Specific 'firsts' on the FR-2 include the ability to record up to 24-bit 192KHz, making it the first choice where the highest quality sound effects acquisition is required; and the optional timecode card which has a fully-featured reader/generator, including 23.976, and external word/video references, making it an ideal basic production or location back-up recorder.

HEADPHONES

SONY MDR-7502

Designed for a broad range of applications, for general sound monitoring in the studio or the field. The rugged MDR-7502 is a high quality, low-cost alternative to consumer headphones.



- ◆ 60Hz~16kHz frequency response
- ◆ 30mm driver unit delivers clear, high quality sound reproduction.
- ◆ Closed-ear design for comfort and reduction of external noise interference.
- ◆ Gold connectors and OFC cord for reliable and stable signal connection and transmission end with 1/4" and 1/8" stereo uni-match plug

SONY MDR-7506

With low impedance, the closed ear MDR-7506 does an outstanding job of cutting down background noise while providing plenty of volume in the studio or field. Ideal for use with camcorders or other equipment with less than powerful amplification.



MDR-7506 Step-up Features:

- ◆ 15Hz to 18kHz frequency response
- ◆ Rugged design for proven reliability in the toughest situations
- ◆ 40mm driver unit for clear, high quality sound reproduction
- ◆ Folding construction for compactness when storing away

SOUND DEVICES HX-3 *Portable Headphone Amplifier*



The HX-3 is a portable, stereo headphone amplifier designed for critical audio monitoring. The audiophile-quality headphone amp is ideal for adding headphone feeds from balanced or unbalanced, line level sources. Each headphone control has its own level control, peak LED, and 1/4" output connector. With its extended bandwidth and high drive capability, the HX-3 can drive headphones of various impedances to high levels with very low distortion, important for monitoring in high SPL environments. It is powered by 2AA batteries or external DC.

Audio Technica ATH-D40FS / ATH-M40FS

AT's Precision Studiophones deliver premium performance, long-lasting reliability and comfort for specialized uses. Built for power and precision with large 40mm diameter drivers, neodymium magnets and CCAW voice coils, they deliver 1600 mW of power handling and very high SPL capability while maintaining exceptional clarity and accuracy. They have adjustable padded headbands and sturdy, ultra-flexible strain-relief cables made of OFC litz wire, with convenient one-side exit.



Circumaural earpieces provide maximum isolation, and can be rotated 180° to permit one-ear monitoring. The ATH-D40fs features an enhanced bottom-end response (from about 20Hz to 500Hz), making it ideal for use with predominantly low-frequency sound sources such as bass instruments and drums. The ATH-M40fs is designed specifically for professional monitoring/mixing, with a flat, extended low-frequency response to 5Hz that ensures accurate sound reproduction.

Sennheiser HD 280 Pro

Designed to exceed the demands of the professional environment, the closed, circumaural HD280 boasts extremely robust construction combined with extensive features that meet the requirements of today's most demanding applications. The unique collapsible design combined with swiveling ear cups, offers maximum flexibility in any application.



- ◆ Accurate, linear sound reproduction for critical monitoring applications
- ◆ Optimum impedance ensures universal compatibility
- ◆ Collapsible, rotating earcups
- ◆ Up to 32 dB of ambient noise attenuation
- ◆ Neodymium magnets for high max. SPL
- ◆ Single-sided, coiled cable with 3.5mm mini jack with locking 1/4" adapter
- ◆ Rugged construction with user-replaceable parts

TAPES/BAGS

PORTABRACE

ACCESSORIES

183

Mini DV Video Tapes

Panasonic

DVM without Chip

60 minute Single.....	3.99
10-Pack.....	3.69 ea. 50-Pack.....3.29 ea.
80 minute Single.....	7.49
10-Pack.....	6.99 ea. 50-Pack.....6.49 ea.

60 Minute DVM -EL with Chip Single.....	9.99 10-Pack.....9.49 ea.
---	---------------------------

Panasonic Pro

AYDVM-PQ

33 min. single...5.29	10-Pack ..4.29 ea.
63 min. single...5.99	10-Pack ..4.99 ea.
83 min. single...9.99	10-Pack ..8.99 ea.

AYDVM-MQ

63 min. single...6.99	10-Pack.....6.49 ea.
83 min. single..11.99	10-Pack...10.99 ea.



Sony

DVM-PR without Chip

30 min. single..3.99	10-Pack....3.79 ea.
60 minute single	4.49
10-Pack.....	4.29 50-Pack....3.99 ea.
80 min. single..8.99	10-Pack....8.49 ea.

DVM-EX without Chip

60 min. single..7.49	10-Pack....7.29 ea.
----------------------	---------------------

DVM-EXM with Chip

60 minute single.....	12.49
60 minute 10-Pack.....	11.99 ea.

Mini-DV Camera Cases

Mini-DV Cameras Cases are made for a variety of cameras. They are customized to accommodate the exact size of your camera, each with special removable pouches and comfortable suede shoulder strap. Also provided are specific camera cradles to hold most cameras, pouches with special features, and/or soft pouches padded to hold delicate parts such as lenses. The cradle is adjustable to fit your camera, giving it a secure home allowing any remaining space for accessories. The CS-DV2 and CS-DV3 have a cradle and removable padded pouch for extra batteries and tapes. The pouch can be used in the case, as a pocket, or used as a shoulder bag. The CS-DV4 comes with a cradle and two zippered stuff sacks. The CS-DV-1 comes with cradle only.



DV Organizers

The DV Organizer provides an extra level of protection and storage options previously unavailable in the case market. Storage space for compact camera, shotgun mic, lavalier mics, receivers, connectors, cables, small tools, extra batteries and tapes are handled easily with a variety of camera cradles, dividers, and pockets thoughtfully arranged to make the DV Organizer the ideal case for compact field production. Easily accommodates matte box and filters if needed.

DVO-2/CR3 Canon GL-2.....	Call
DVO-2/CR4 Panasonic DVX-100,100A, DVC-80.....	Call
DVO-2/CR3 Sony DSR-PD170, 150, DCR-VX2100, VX2000.....	Call

Mini-DV Rain Slicker

The Mini-DV Rain Slicker is custom fitted to each camera model. Flaps, vinyl windows and zippered openings provide optimum ease of operation. Cameras with fold-out video screens are shrouded with a black fabric hood that makes viewing LCD monitors easier on bright sunny days.

Mini-DV Rain Slicker works with tripod or in the hand held mode. It is made from a newly designed Cordura fabric that withstands extremes in temperatures and provides excellent rain protection.



Hip Pack

The HIP PACK can be used either in the belly position or fanny position. It has a re-enforced interior main compartment and a wide quick release waist belt. The main compartment will hold tapes and batteries or small cameras. Extra front and top pockets hold small items. There is a pocket for your keys on the waist belt. Comes with a Porta Brace water bottle.

ORDER & INFO. (212) 444-5010 • FAX: (212) 239-7770 (800) 947-7008
1-800-947-5525 • www.bhphotovideo.com



LOWEPRO

EDIT COLLECTION

ACCESSORIES

184

The Edit Collection of digital video and miniDV camera bags is designed to safely and easily transport nearly every digital video camera available on the market today. They offer tremendous storage options in a light compact size, providing a truly functional and durable storage and transport system for digital video cameras and accessories.

They all feature a front pocket with interior mesh organizer and visibility window for easy access to batteries and other accessories, a reverse-zipper, a padded handle with a comfort-grip, and padded Tricot lining that protects LCD screens from scratches and dust.

Edit 120:
Holds a digital camcorder plus accessories. 6.5 x 3.25 x 5.25" (WDH)**19.95**

Edit 140:
Slightly larger than the Edit 120. Dimensions are 8.75 x 4.5 x 4.5" (WDH)**24.95**

Edit 140+:
Similar to the above bags, with a 8 1/4 x 5 x 2" detachable SlipLock compartment to store additional cords and accessories. 8.75 x 4.5 x 4.5H" (WDH)**29.95**

Edit 160:
Sophisticated, full-featured bag for digital video cameras with room to spare for accessories or a still camera. 9.5 x 4.5 x 6" (WDH)**29.95**



NOVA SHOULDER BAGS



Nova Micro AW: The smallest of the Nova Series can be carried on the non-slip shoulder strap, by the padded handle or add the optional Belt & Buckle and use it as a belt pack. An OverLap Zipper gives your gear extra protection and there is an outer accessory pocket and belt loops. Holds a super-compact digital video camera. 5 x 3.5 x 6" (WDH). Available in Black, Navy Blue, Forest Green, Grey, or Red.....**24.95**

Nova Mini AW: For days when you want to travel light. Accessory pockets stow the extras, while the OverLap Zipper offers extra protection. Carrying options include a non-slip shoulder strap, a padded handle and belt loops for your belt or an optional Belt & Buckle. Holds a digital camcorder. It's dimensions are 6.5 x 3.5 x 6.5" (WxDxH), it is available in Black, Navy Blue, Forest Green, Grey and Red.....**27.95**

Nova 1 AW: A very compact bag for those who like a smaller system. Features include an OverLap Zipper for 360° protection, No Drop Pocket for filter changes, interior and exterior pockets, a padded, contoured shoulder strap, padded handle and belt loops. Dimensions are 7.75 x 4 x 6.5" (WDH)**32.95**

Nova 2 AW: This small, redesigned light bag loves to travel. The Nova 2 AW has hi-tech materials; and an all-weather cover to protect gear from the elements, dust and torrential rain. It has a customizable interior; OverLap Zipper; NoDrop Pocket for film and filter changes; many inner and outer pockets; a curved, pressed-foam shoulder strap; belt loops; and padded handle. 8.5 x 4.25 x 7.75" (WxDxH)**38.95**

Nova 3 AW: The Nova 3 AW has a sleek new look and an All Weather Cover to help guard your gear. Movable dividers adjust the interior for your equipment. Film and accessories go in the inner and outer mesh pockets, security pocket and front NoDrop Pocket. Includes an OverLap Zipper; rugged metal hardware; a curved, pressed-foam shoulder strap; and padded handle. Size : 9 x 6 x 7.5" (WxDxH)**43.95**

Nova 4 AW: The perfect travel bag with adjustable dividers that customize the interior for your system. It features an All Weather Cover; a curved, pressed-foam shoulder strap; an OverLap Zipper; a NoDrop Pocket; padded handle; belt loops; tough metal hardware; inner and outer mesh pockets; and back security pocket. 11 1/2 x 6 x 7 3/4" (WDH).....**54.95**

Nova 5 AW: This lightweight shoulder bag features an All Weather Cover for really bad weather and dust, a sleek exterior and a curved, pressed-foam shoulder strap. An OverLap Zipper offers extra protection; a NoDrop Pocket delivers safer film and filter changes. Size: 14 x 6 x 8.5" (WxDxH).....**64.95**



For Any Inquiries Regarding Your Order, Call Our Customer Service:
(800) 221-5743 • (212) 239-7765 • FAX: (800) 947-2215 • (212) 239-7549

LOWEPRO

SHOULDER BAGS

ACCESSORIES

185

The Portable Studio Series shoulder bag collection features pro-quality shoulder bags that are created from water-resistant 1200D ballistic TXP and 2000D ballistic nylon fabric. They have an OverLap Zipper; an All Weather Cover for rough weather and dust; extensive pockets; a thickly padded shoulder strap and padded leather handle, and attachment loops for optional SlipLock accessories.

Commercial AW DV: A large, pro-quality shoulder bag with two detachable Pro AW Side Pockets, a thickly padded shoulder strap, padded leather handle and Belt & Buckle. The totally flexible, modular interior lets you stow bodies and most-used lens horizontally or vertically — or flip the divider for a different layout. It accepts a digital video camcorder (up to a Canon XR1S) with lens attached, 2 extra lenses and peripherals. Dimensions are 19 x 12.5 x 11" (WDH).....**188.95**

Compact AW DV: A hardworking shoulder bag that includes lots of inner and outer pockets and two removable Pro AW Side Pockets. It can hold a digital video camcorder (up to a Canon GL-2), batteries and peripherals. Interior size is 13 x 7.75 x 8" (WDH)**141.95**



D-RES SHOULDER BAGS

D-Res 240 AW

A convertible beltback/shoulder bag to carry on its removable shoulder strap or on the hide-away, quick-release waistbelt. Designed for all your electronic toys; you can expand your carrying capacity with optional SlipLock add-ons. The front compartment has movable dividers to organize your gear, and there's a handheld PC compartment and special pockets for memory cards and batteries. An All Weather Cover protects your gear from rain, snow, dust and sand. It holds a digital camera; PDA; cell phone, memory cards and 4 AA batteries. The interior front compartment is 10 x 2.5 x 6.5", the notebook compartment is 10 x 1.5 x 6.5"**45.95**



D-Res 240 AW

D-Res 220 AW

An intelligent solution designed with movable dividers and an All Weather Cover to carry a compact digital video camera system. There is also space for a PDA, a PC card in its case, 4 AA batteries; memory cards or MiniDV tapes; small accessories, and a cell phone. Carry it on the removable shoulder strap or fasten to any SlipLock base product or belt. The interior front compartment is 6 x 2.5 x 6.5", and the back compartment is 6 x 1.25 x 6.5**26.95**



D-Res 220 AW

D-Res 40 AW

A versatile bag for many digital still or video cameras, including those with unconventional shapes. Designed to be carried on the shoulder strap or attached to your belt, the bag has inner pockets for memory cards and tapes. A movable divider customizes the interior for your system. Features a patented All Weather Cover, padded handle and quick-release shoulder strap. Attachment tabs fasten to your belt or any SlipLock base product. It can hold a digital still or video camera, plus memory cards, batteries or CD/DVD player and accessories. Its interior size is 7 x 5 x 6"**32.95**

D-Res 50 AW

A wider, deeper bag that accommodates larger digital cameras and digital video cameras and unusual shapes. An adjustable divider allows you to customize the D-Res 50 AW for your system. There's a laminated mesh pocket, padded handle and a patented All Weather Cover for protection against dust, rain and sand. Carry it on the quick-release shoulder strap and use the belt loops to attach it to your belt for additional stability. It holds most digital still or video camera systems, MiniDV tapes, CompactFlash memory cards or SmartMedia cards in cases, and accessories. Its interior size is 9 x 5 x 6"**34.95**

ORDER & INFO. (212) 444-5010 • FAX: (212) 239-7770 (800) 947-7008
1-800-947-5525 • www.bhphotovideo.com



TAMRAC

VIDEO BAGS

ACCESSORIES

186

5201

Explorer 1

The Explorer 1 is designed to hold most popular compact camcorders. This compact shoulder bag quickly converts to a comfortable hip pack by removing the BioCurve padded shoulder strap and unsnapping the hidden Tuck-A-Way hip belt. The main compartment features Tamrac's Dual Foam Technology that combines closed-cell foam to provide maximum shock protection with open-cell foam for vibration dampening and a custom fit. Inside the total coverage top is an accessory pocket for lens cleaning paper. The front pocket has paraphernalia pockets and features the Memory & Battery Management System that uses red flags to identify available memory cards and batteries. You can add Tamrac accessories using the attachment slots for their Strap Accessory System (S.A.S) and Modular Accessory System (M.A.S.) products to customize this easy-to-use, compact carrying system.

• Internal Dimensions: 8½ x 4 x 6½" (WDH) • Weight: 1 lb. 8 oz. • Colors: Black, Blue, Green



5382

Double Decker 2 Camcorder/Camera Bag

This compact double decker is perfect for a digital camera or compact camcorder and accessories. In the top compartment, a foam-padded divider protects and provides a custom fit to equipment. The lower compartment is also foam padded and can be separated from the upper compartment to store an AC adapter, cords and other accessories that are not required during the day's activity. A front zippered pocket features the Memory & Battery Management System that uses red flags to identify available memory cards and batteries from ones that are used up.

- Top compartment internal dimensions: 5 x 3 x 5" (WxDxH)
- Bottom compartment internal dimensions: 5 x 4½ x 1½" (WxDxH)
- Weight: 13 • Color: Black

5285

Video-Photo 5 Double Decker Camcorder/Camera Bag

This is a very full-featured bag for camcorders up to 9¾" long. The top compartment is fully foam-padded with an adjustable foam-padded divider and a Windowpane-Mesh accessory pocket. A front zippered pocket provides more room for accessories. In back a Tuck-A-Way hip belt quickly converts the shoulder bag into a comfortable hip pack for hands-free action. The lower compartment is also foam-padded and can be separated from the upper compartment to store accessories that are not required during the day's activity.

- Top Compartment Internal Dimensions: 9¾ x 4¾ x 5¾" • Weight: 1 lb. 9 oz.
- Bottom Compartment Internal Dimensions: 9¾ x 4½ x 2" • Colors: Black

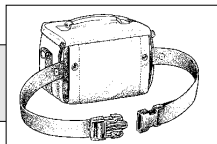

Models 5201 and 5285 feature the Tuck-A-Way hip belt for hands-free carrying convenience



www.bhphotovideo.com

TAMRAC

VIDEO BAGS

Digital Series

Tamrac's Digital Series offers unparalleled protection, features and functional design. Total coverage tops provide quick access and complete rain coverage. Because DV camcorders are mechanically fragile and electronically sensitive, Tamrac uses exclusive Dual-Foam Technology that combines closed-cell foam for maximum shock protection with open-cell foam for vibration dampening and a custom fit. The front pockets have Universal Memory and Battery Management Pockets inside to secure memory cards and batteries. Each bag is constructed of ultra-strong, waterproofed ballistic nylon and lined with smooth nylon that doesn't collect dust or create lint.

5696 Digital 6 Video/Photo Bag



Dual Foam Technology combines closed-cell foam to provide maximum shock protection with open-cell foam for vibration dampening and a custom fit. Features a Speed Flap top for quick access, a zipper-closing Speed Pocket on the lid and a Windowpane-Mesh pocket inside the top for filters and lens caps. A front accessory pocket with inside secures various types of memory cards and batteries. A special fitted pocket holds extra memory cards. In addition to the EasyGrip carrying handle,

the Digital 6 has an adjustable, removable shoulder strap and belt loop to carry it hands-free on a belt.

- Internal Dimensions: 5 $\frac{1}{2}$ x 3 $\frac{1}{2}$ x 5 $\frac{1}{2}$ " (WxDxH)
- Weight: 11 oz. • Colors: Black, Blue, Steel Gray

5697 Digital 7 Video/Photo Bag

The main compartment has an adjustable, foam-padded divider and has Dual Foam Technology for vibration dampening and a custom fit. A Windowpane-Mesh accessory pocket in the top holds filters or cleaning materials. The front zippered pocket has paraphernalia pockets to hold tapes, a phone or notepad, and also features two Universal Memory & Battery Pockets for memory cards and batteries. In addition to the EasyGrip carrying handle, the Digital 7 has an adjustable shoulder strap and belt loops to carry it hands-free on a belt.



- Internal Dimensions: 8 x 3 x 5 $\frac{1}{2}$ " (WxDxH)
- Weight: 1 lb. • Color: Black

5698 Digital 8 Video/Photo Bag



The main compartment has two adjustable, foam-padded dividers and has Dual Foam Technology that combines closed-cell foam to provide maximum shock protection with open-cell foam for vibration dampening and a custom fit. A Windowpane-Mesh accessory pocket in the top holds filters or cleaning materials. The front zippered pocket contains paraphernalia pockets to hold tapes, cords and a small notepad, and also features two

pockets to secure memory cards and batteries. In addition to the EasyGrip carrying handle, the Digital 8 has an adjustable shoulder strap and belt loops to carry it hands-free on a belt.

- Internal Dimensions: 9 x 3 $\frac{1}{2}$ x 5 $\frac{1}{2}$ " (WxDxH)
- Weight: 1 lb. 2 oz. • Color: Black

5685 Digital Double Decker

Specially designed divider system accommodates a wide range of camcorders, extra lenses, batteries and other accessories. The lower compartment can be separated from the bag and is an ideal place to store chargers and adapters. Windowpane-Mesh accessory pocket in the top. Front zippered pocket contains paraphernalia pockets, and two pockets to secure memory cards and batteries. In addition to EasyGrip handle, it has an adjustable shoulder strap and belt loops to carry it hands-free on a belt.



- Top compartment internal dimensions: 9 $\frac{1}{2}$ x 4 $\frac{1}{4}$ x 5" (WxDxH)
- Bottom compartment internal dimensions: 9 $\frac{1}{2}$ x 4 x 2" (WxDxH)
- Weight: 1 lb. 10 oz. • Color: Black

TAMRAC

VIDEO BAGS

Tamrac's commitment to providing the ultimate in function, materials and craftsmanship is evident throughout their video bag line. Constructed of Cordura nylon that has been weather-proofed with two urethane coatings, each bag is padded with dense, closed-cell foam and features an adjustable divider for complete equipment protection. Windowpane-Mesh pockets are featured in the lid of each bag, and all but the 975 feature Tamrac's ZipDrop front pocket, providing storage space for plenty of accessories. A strong plastic platform is found in the bottom of the 972, 973, 974, 975 and 976 for maximum support and protection. The two larger models (974 and 976) have a torsion bar stabilizer in the lid for even weight distribution. All Tamrac camcorder bags have an adjustable shoulder strap and a five year warranty. Tamrac's Tuck-A-Way hip belt, featured on the 972, 974 and 975 quickly converts to a comfortable hip bag for hands-free carrying convenience.

972

Micro Camcorder Convertible Plus

Designed to hold and protect camcorders up to 9½" long in a compact convertible carrying case, the 972 features Padded ABS Plastic platform for added stability and support, adjustable divider for custom fit, and Windowpane-Mesh Pocket inside top for lens paper, caps and accessories. The bag also features Tamrac's Tuck-A-Way hip belt.

• Internal Dimensions: 10 x 4¼ x 5" (WDH) • Weight: 1 lb. 7 oz. • Colors: black, gray, forest green

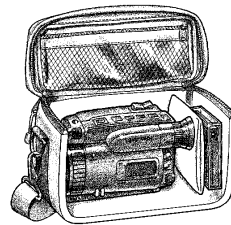

974

Mini Camcorder Convertible

Designed for camcorders up to 12½" long, the 974 gives full protection to your equipment while providing real mobility for the active video enthusiast. This bag features gives ABS Plastic Platform in the bottom for added stability and support, Tamrac's Tuck-A-Way hip belt, Zip Drop Front Pocket with organizer for accessories, Weather flap to protect zipper to main compartment, Windowpane-Mesh Instruction Booklet Pocket inside the top, and Smooth Pack Cloth Back to protect clothes from abrasion.

• Internal dimensions: 12½ x 5 x 6½" (Wx Dx H) • Weight: 1 lb. 15 oz. • Colors: Black

975

Double Decker Camcorder Convertible

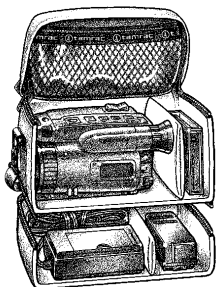

Really two bags that zip together, the 975 allows you to store charger, cords and accessories in a removable, zippered lower compartment. When the lower extra accessory compartment is removed, it creates a lighter bag for camcorders up to 10" long. The main compartment is completely foam padded. The bag features a sturdy carrying handle, Tuck-A-Way hip belt, and a Windowpane-Mesh pocket in the lid for instruction manuals, cables etc. Includes removable, adjustable shoulder strap with non-slip patch.

• Top compartment internal dimensions: 10 x 4½ x 4½" (Wx D x H)
• Bottom compartment internal dimensions: 10 x 4½ x 2" (Wx D x H)
• Weight: 1 lb. 7 oz. Colors: Black



TAMRAC

VIDEO BAGS

976

Medium Camcorder Bag

Designed to hold and protect camcorders up to 14" long, the 976 has a Torsion Bar Stabilizer Strut in the top to evenly distribute weight and ABS Plastic Platform in the bottom for added stability and support. Features include Windowpane-Mesh instruction booklet pocket inside top, full length zippered back pocket, Zip Drop Front Pocket organizer for accessories, Smooth Pack Cloth Back to protect clothes from abrasion.

- Internal Dimensions: 14¼ x 4½ x 7¼" (WxHxD)
- Weight: 2 lbs. 2 oz. • Color: Black



979

Double Decker Camcorder Convertible

The 979 is specifically designed for transporting camcorders like the DCR-VX2100, Canon GL-2 and others up to 16" in length. To accommodate all the necessary accessories, the 979 has a large, padded front pocket with organizer pockets and a mesh pocket to store cables and cords. Inside, numerous compartments provide storage for additional accessories like batteries, headphones, and extra microphones. A strong plastic platform in the bottom protects equipment.

- Internal Dimensions: 16 x 4½ x 8" • Weight: 3 lbs. 2 oz. • Colors: Black

ACCESSORIES

189

TEK Series Carry-On Camcorder Case

Specifically designed to fit in the overhead compartment of airplanes, the TEK Series is constructed of PowerGrid Cordura and is ideal for camcorders such as the Sony DCR-VX2100, Canon GL-2 and XL-1s. The zipper opening main compartment is completely foam padded and reinforced with plastic armor for equipment protection. There is additional foam-padded armored protection for the viewfinder.

On the front of the cases is a large ZipDrop pocket with internal organizer pockets for accessories, plus a full-length zippered mesh pocket for smaller items. Dual zippered pockets on the back provide convenient storage for documents and accessories. The military spec. black EDP-coated hardware prevents unwanted reflections. The double webbing handles have comfortable leather wraps for carrying comfort and the heavily padded detachable non-slip leather shoulder pad takes the strain out of carrying a heavy load. Heavy-duty YKK coil zippers have convenient zipper pulls for fast action.



2248 Sub Compact Camcorder Case

- ◆ Weight: 5 lbs. 5 oz.
- ◆ Dimensions: 18½ x 6½ x 9¼" (WxDxH)
- ◆ Colors: Black, Forest Green



2249 Sub Compact Camcorder Case Extended

- ◆ Weight: 6 lbs.
- ◆ 22½ x 6½ x 10" (W x D x H)
- ◆ Colors: Black, Forest Green



2250 Compact Carry-On Camcorder Case

- ◆ Weight: 6 lbs. 5 oz.
- ◆ 22½ x 6½ x 10" (W x D x H)
- ◆ Colors: Black, Forest Green

ORDER & INFO. (212) 444-5010 • FAX: (212) 239-7770 (800) 947-7008
1-800-947-5525 • www.bhphotovideo.com



AMPHIBICO

VH-2100

ACCESSORIES

190



Underwater Housing for the Sony DCR-VX2000/2100 or DSR-PD150/170

Designed for professional underwater use, the VH-2100 is an aluminum housing for the DCR-VX2000/2100 and DSR-PD150/170 that allows full use of camcorder functions at depths of 330-ft. The housing features electronic push-button controls and manual controls, provides excellent underwater balance, and has a unique front camera entry design that makes camcorder installation easy.

- ◆ 14 electronic push-button controls including: standby, record, momentary focus, zoom wide/telephoto, iris control, review, screen display, white balance, review Also includes video light intensity controls.
- ◆ Manual controls include focus, iris, Power On/Off, and Standby-Record.
- ◆ Viewfinder features 2X magnification, adjustable focus and is tilted 25° for full-frame viewing through the face mask.
- ◆ Amphibious Dual Hydrophones add dimensional sound to underwater video.
- ◆ Bayonet mounted, fully-coated, 0.55x amphibious wide angle conversion lens is vacuum sealed for maximum anti-fog protection. The lens includes a square lens hood complete with 3 x 4" filter slot.
- ◆ A sensor installed into the lowest part of the housing sets off a flashing red LED on the pistol grip if moisture is detected.
- ◆ Aluminum marine grade housing coated with 2 coats of polyurethane and marine grade brass with stainless steel hardware, that provides corrosion resistance and ideal protection in any environment.
- ◆ Pistol grips are ergonomically designed for cold water gloves or warm water use.
- ◆ Bright green LED located on the right hand pistol grip flashes when camcorder is recording.
- ◆ Includes an internal filter ring to accommodate either color correction filters or diopters for macro work and a #35 external glass 3 x 4" filter. The filters provide true underwater color and heightened contrast for sharper, brighter underwater hues.
- ◆ 2 Auxiliary ports

VH-2100 3250.00

DIVE BUDDY "PLUS"

Housings for Sony DV Camcorders

A compact aluminum housing designed for Sony DV camcorders, the Dive Buddy "Plus" includes a hydrophone, Amphibico's bayonet-mounted wide angle conversion lens, and a moisture sensor, five electronic push button controls which access 11 key camera functions, an internal flip filter for color correction filters or macro diopters, O-ring kit and 2 light shoes.



- ◆ Five electronic push button controls: Record/Standby, Telephoto, Wide Angle, Off and Photo (if supported by the camcorder)
- ◆ Built with marine grade aluminum and marine grade brass with stainless steel hardware that allows full use of camcorder features to depths up to 330'.
- ◆ Toggle between manual to autofocus
- ◆ External hydrophone for accurate underwater sound pick-up
- ◆ Extra wide quality optics (full zoom capability) .55x rectilinear wide angle providing 64° field of view
- ◆ Electronic moisture sensor with a flashing red light that lets you know if any water is leaking into the housing.
- ◆ Flashing green tally light when recording
- ◆ VCR mode: Play, Stop, REW, FF, Pause
- ◆ Rear Viewfinder
- ◆ Auxiliary port
- ◆ Approximate weight: 7.5 lbs (out of water without camera)

Dive Buddy "Plus" for Sony DCR-TRV Series Camcorders 1525.00



EQUIPMENT LEASING AVAILABLE

IKELITE

UNDERWATER SYSTEMS

Video Housings

Ever since scuba began, divers have tried to capture the wonders of the underwater world and bring them to the surface to share with others. While still photography shows beautifully vivid colors and wondrous creatures of the sea, the video camera captures the added dimensions of time and motion. Video can display the unbelievable color changes of an octopus, the eeriness of a slow moving shark in the distance, or the synchronized ballet of a school of bait fish. And with today's ultra-compact, auto-everything camcorders it is easier than ever to capture exciting and memorable underwater footage. Ikelite offers a full range of video housings for Canon, Sony and JVC camcorders. Designed for today's traveling diver, they incorporate a variety of specialized features and most include the dome port, video-eye magnifier, top-handle and quick release base.



ACCESSORIES

191

FEATURES

Easy-to-Use

- ◆ Ikelite housings are a joy to use. Their dependable, easy-to-operate controls are conveniently placed at your fingertips. Camera installation is quick and easy. Housings are sized and weighted for near neutral buoyancy offering stability and superb handling underwater.
- ◆ Ikelite housings operate safely to 60m (200-ft) and have proven to be the safest enclosures money can buy. All housings are sized and weighted for near neutral buoyancy and superb handling underwater.

Easy-To-Use Controls

- ◆ Dependable, easy-to-operate controls are conveniently placed at your fingertips and kept water tight with Quad-Ring seal glands. Ikelite pioneered the quad-ring seal gland and it has proven to be the most reliable method for sealing camera controls in underwater housings.
- ◆ Ikelite's mechanical controls offer several advantages over electronic controls—the leading one being dependability. Thousands of Ikelite controls are in use with a performance record that approaches perfection. Mechanical controls allow the housing to feature more control functions resulting in a wider range of creative possibilities.

Instant Visual Inspection

- ◆ Ikelite Video housings are unique in the industry in that they allow visual inspection of the camcorder, control functions, and all sealing surfaces—offering visual insurance your system is safe.
- ◆ Ikelite offers two types of durable clear housings: clear polycarbonate injection molded housings or clear acrylic tubing shrouded with cast aluminum end caps. Both housings are exceptionally strong and corrosion resistant for trouble-free performance.

External Wide Angle Lenses

- ◆ Many video housings have a threaded port that allows the use of external wide-angle lenses manufactured by Inon and Sea & Sea.

Color Monitor

- ◆ The LCD color monitor on several camcorder models can be viewed underwater. Some monitors can be seen from the rear while others can be viewed thru the side of the housing. The optional External Mirror #9290.95 adheres to the outside of select Ikelite Video Housings allowing larger LCD screens to be viewed from the rear of the housing. Simply peel and stick.

Super-Eye Magnifier

- ◆ A special viewfinder enhancement device, the Super-Eye magnifies the camcorder's viewfinder image allowing you to see exactly what the camera sees—even while wearing a diving mask.

UR/PRO Color Filter

- ◆ The patented UR/Pro color correcting filter enhances the warm reds and oranges that are so easily diminished underwater. The filter secures to the outside of the lens port offering easy installation and removal. Provides quality results with available sunlight underwater to 80' depth.

Removable Handle

- ◆ The bar and handle system is easily removable from the housing to facilitate packing.

Quick-Release Base

- ◆ The quick release base removes instantly for traveling or for attaching a Pro Video-Lite to enhance color. The bar and handle system can also be easily removed from the housing to facilitate packing.

ORDER & INFO. (212) 444-5010 • FAX: (212) 239-7770 (800) 947-7008
1-800-947-5525 • www.bhphotovideo.com



IKELITE

UNDERWATER SYSTEMS

ACCESSORIES

192

IKELITE VIDEO CHART FOR JVC CAMERAS

Model	Type	Controls	Features	Weight	Size (WHD)	Battery
6011.24	Clear Molded with Flat Port	P, S/S, Z FL, PH, MC	Side view LCD Screen W/A option *4 or 5	9 lbs. 4 kg	11 x 8 x 11" 27 x 20 x 28cm	BN-V408 BN-V416
6011.27	Clear Molded with Flat Port	P, S/S, Z FL, PH	Super-Eye; Side view LCD Screen Sony W/A Lens option *5	9 lbs. 4 kg	11 x 8 x 11" 27 x 20 x 28cm	BN-V408 BN-V416
6011.30	Clear Molded with Flat Port	P, S/S, Z FL, PH, MC	Rear view LCD Screen	6 lbs. 3 kg	11 x 8 x 7" 27 x 20 x 16cm	BN-V107 BN-V114
6012.30	Clear Molded with Flat Port	P, S/S, Z, FL, PH	Super-Eye, Side view LCD Screen W/A option *4 or 5	9 lbs. 4 kg	11 x 8 x 9" 27 x 20 x 24cm	BN-V408 BN-V416
6012.32	Clear Molded with Flat Port	P, S/S, Z FL, PH	Super-Eye, Side view LCD Screen W/A option *4 or 5*	9 lbs. 4 kg	11 x 8 x 9" 27 x 20 x 24cm	BN-V408 BN-V41

IKELITE VIDEO CHART FOR SONY CAMERAS

6037.12	Clear	P, S/S, Z, FL, PH, WB	Video-Eye Raynox 0.66x W/A Lens	20 lbs. 9 kg	14 x 14 x 14" 38 x 38 x 37cm	NP-F750 NP-F960
6037.75	Clear-Molded w/ Dome Port	P, S/S, Z FL, PH, MC	Rear view; LCD Screen Sony W/A Lens option	7 lbs. 3 kg	11 x 8 x 8" 27 x 20 x 20cm	NP-FS11 NP-FS31
6037.79	Clear Molded w/ Dome port	P, S/S, Z FL, PH, MC	Rear view LCD Screen Sony W/A Lens option	7 lbs. 3 kg	11x8x8" 27 x 20 x 20cm	NP-FM30 NP-FM70
6037.80	Clear Molded w/ Dome Port	P, S/S Z FL, PH, MC	Rear view LCD Screen Sony W/A Lens option or *5	7 lbs. 3 kg	11 x 8 x 8" 27 x 20 x 20cm	NP-FM30 NP-FM70
6037.81	Clear Molded w/ Dome Port	P, S/S Z FL, PH, MC	Super-Eye Rear view LCD Screen	9 lbs. 4 kg	12 x 9 x 8" 30 x 22 x 19cm	NP-FM50 NP-FM91
6037.84	Clear Molded w/ Flat Port	P, S/S, Z FL, PH, MC	Super-Eye, Rear view LCD Screen W/A option *4 or 5	9 lbs. 4 kg	12 x 9 x 8" 30 x 22 x 20cm	NP-FM50 NP-FM91
6037.90	Clear Molded w/ Dome Port	P, S/S, Z, FL FM, PH, WB	Super-Eye, Rear view LCD Screen Raynox 0.65x W/A Lens	9 lbs. 4 kg	11 x 8 x 11" 27 x 20 x 28cm	NP-F330 NP-F750
6037.95	Clear Molded w/ Flat Port	P, S/S, Z, FL MF, PH, WB	Super-Eye, Rear view LCD Screen Raynox 0.5x W/A Lens	9 lb. 4 kg	11 x 8 x 12" 27 x 20 x 30cm	NP-FM30 NP-FM70
6038.05	Clear Molded w/ Flat Port	P, S/S, Z FL	Super-Eye; Side view LCD Screen W/A option or *5	9 lbs. 4 kg	11 x 8 x 11" 27 x 20 x 28cm	NP-FM50 NP-FM70
6038.29	Clear Molded w/ Flat Port	P, S/S Z FL, PH, MC	Super-Eye; Side view LCD Screen Sony W/A option or *5	9 lbs. 4 kg	11 x 8 x 9" 27 x 20 x 24cm	NP-FM50 NP-FM71

IKELITE VIDEO CHART FOR CANON CAMERAS

6040	Clear Molded w/ Flat Port	P, S/S, Z FL, PH, MC	Super-Eye W/A option or *4 or 5	9 lbs. 4 kg	11 x 8 x 9" 27 x 20 x 23cm	BP-511 BP-522
6042	Clear Cylindrical w/ Flat Port	P, S/S, Z, FL MF, PH, MC WB	Super-Eye Canon Lens required *7	18 lbs. 8 kg	13 x 11 x 14" 33 x 28 x 37cm	BP-915 BP-945

* Optional Raynox 0.65x or 0.7x wide angle lens from Ikelite.

All housings feature:

Dome Port, External Removable UR/Pro Underwater Color Filter, and Quick-Release Base.
Sizes shown include handles and base.

JVC

Camera	Ikelite
DV3000	6011.24
DV700	6011.27
DVP1/3/5/7/8/9	6011.30
DC20/30/40/50/60/70/90	6012.30
DV500	6012.32

SONY

Camera	Ikelite
DSR-PD150	6037.12
DSR-PD170	6037.14
DCR-PC5/6	6037.75
DCR-PC6/8/9/101	6037.79
DCR-PC103/104/105	6037.80
CCD-PC100	6037.81
CCD-PC110	6037.82
DCR-PC115/120	6037.84
DCR-TRV120/520	6037.86
DSR-PD100	6037.90
DSR-PDX10	6037.95
DCR-TRV118/145/250/318	6038.05
DCR-TRV345/350/351/355	6038.05
DSR-PD150	6038.29
DSR-PD170	6038.30

CANON

Camera	Ikelite
MV-500/500i/530i/550i	6040
MV600/600i/630i/650i	6041
DM-GL2/DM-XM2	6042

CONTROLS:

P.....Power	WB.....White Balance
S/S.....Start/Stop	PB.....Playback
Z.....Zoom	ES.....Edit Search
FL.....Focus Lock	SB.....Standby



IKELITE

UNDERWATER VIDEO LIGHTS

Pro Video-Lite Series

The Pro-Video Lite combines remarkably even lighting coverage with a compact design that attaches easily and maintains the exceptional balance of the Ikelite video housing. The light head comes with a 50- or 100-watt primary lamp and features a built-in 20-watt modeling/diving light. A unique 13-volt nicad battery pack snaps underneath any Ikelite housing with the quick-release toggle, replacing the removable housing base. Add a second Lite head for dual intensity choices for different camera-to-subject distances. Combine two packs to double run time. The rotating on/off/on switch mounts to the handle of the camera housing for fingertip operation. Adjustable 12" mounting arm provides the flexibility to aim the light head in a multitude of positions. Convert to the SpD specialty diving light by selecting the SpD head and tank mount.



ACCESSORIES

193

- ◆ Combines exceptionally even lighting coverage with a compact design that attaches easily. Provides easy handling while adding very little weight to the housing underwater.
- ◆ Available with 50- or 100-watt primary video lamps, and includes a separate 20 watt modeling/diving light. The ultra-wide 100° primary light coverage is free of hot-spots.
- ◆ An adjustable 12" mounting arm provides the flexibility to aim the light head in a multitude of positions.
- ◆ Contoured, lightweight (15 oz.) battery pack snaps underneath the housing with a quick-release toggle system, replacing the removable housing base. Mounting the battery underneath provides better handling than a self-contained system on the end of an arm.
- ◆ A switch is mounted in the cord that connects the battery pack and lite head. This switch mounts on the housing handle for convenient finger-tip operation.
- ◆ The pack can power one or two lite heads (a second light head can be added for dual intensity). With optional stacking toggle, two packs can be combined to double the run time.
- ◆ Supplied PRO/SpD Smart Charger provides more complete charging of the batteries, plus offers a trickle maintenance charge, keeping batteries cool for prolonged life. Operating on any input voltage from 90-240 volts AC, the charger can charge the 13v (#1400) nicad battery in 5 hours. The ideal, dependable charger for the traveling diver.

Complete Pro Video-Lite II Systems

Complete systems with lite head, mounting arm, battery pack, PRO/SpD Smart charger, and cable with in-line switch.

50-WATT VERSION

6340.55 50W with USA Charger Plug	439.95
6340.56 50W with European Plug	439.95
6340.57 50W with Australian Plug	439.95

100-WATT VERSION

6340.05 100W with USA Charger Plug	439.95
6340.06 100W with European Plug	439.95
6340.07 100W with Australian Plug	439.95

Pro Video-Lite II Accessories

Complete systems with lite head, mounting arm, battery pack, PRO/SpD Smart charger, and cable with in-line switch.



REPLACEMENT LAMPS

0049.42 20-watt Modeling Lamp	26.95
0049.50 50-watt Primary Lamp	14.95
0049.51 100-watt Primary Lamp	14.95

BATTERY PACK

Stack two battery packs with the stacking toggle and battery connecting cable.

1400 Spare 13v 4.5 Ah NiCad Pack	234.95
1405.06 Battery Cable	35.95
9362 Stacking Toggle	14.95

ORDER & INFO. (212) 444-5010 • FAX: (212) 239-7770 (800) 947-7008
1-800-947-5525 • www.bhphotovideo.com



EWA MARINE

WATERPROOF HOUSINGS

ACCESSORIES

194

On a trip to Disneyland, to Paris or to Yellowstone Park, you can be surprised by rain. Not only sea spray or rain but high humidity – even on a sunny day can kill the electronics of any modern video camcorder. The repair is often impossible or more expensive than the air-tight and waterproof EWA housing. With a practical operating depth of 30 feet; colors of corals and tropical fish turn out brighter than on regular film. EWA makes models to fit hundreds of camcorders. The correct size must be selected specifically for a camcorder model with regular size battery. Camcorder buttons are controlled through the flexible skin from the outside. Autofocus works above water. Underwater, the manual focus setting allows sharp pictures within the operating range.



- ◆ Unlike hard housings which are sealed with sensitive O-rings, require careful maintenance and can leak without warning, EWA Marine's housings require no such rings and their waterproofness is virtually independent of depth. The housings are ultra-sonic welded, UV resistant and feature their own carry strap. All underwater housings are sealed via a triple stainless steel, non-corrosive screw closing rail.
- ◆ EWA Marine flexible housings are extremely easy to maintain. There are no "O"-rings to maintain as found in hard housing that may contain as many as 12-18 rings (a hard housing is only as good as its "O"-ring seals). These rings must be constantly inspected, greased, and many times - replaced. EWA Marine housings only require a quick rinse in fresh water, towel dry, keep them away from sharp objects, and do not allow them to bake in the sun.
- ◆ Although they have a practical operating depth of 30', flexible housings like EWA Marine's can be successfully taken to hundreds of feet with absolutely no damage to the housing. The depth limitation is due to the design of the actual camcorder. For example, water pressure exerted on a flexible housing causes the housing to compress. This compression effects various protruding camera controls such as a shutter button, on/off switch, or zoom button. Those designed with greater protruding controls will be even more adversely effected with "sticking" control buttons in less depths of water. Depth operation is dependent upon the construction of the camera and not the housing.
- ◆ Many of the EWA Marine flexible housings weigh less than two pounds as compared to housings weighing in at 10-20 lbs. They also serve as durable protection above water in rain and snow conditions. Housings fold for easy storage in a camera bag.



FEATURES

- ◆ EWA Marine housings are manufactured from double laminated PVC and have an optical glass port. They are rated to 10 metres (33-ft.) underwater.
- ◆ They are supplied in a handy yellow carry-case which has a water-proof interior and zippered side-pocket.
- ◆ They have a pair of non-corrosive and seawater resistant clamping rails which fit together for perfect sealing. They tighten by means of knurled thumb screw knobs.
- ◆ Straps at the bottom allow weights to be attached for perfect buoyancy underwater.
- ◆ Perfect for snorkeling or shallow diving, sandy, dusty, humid or foul weather conditions these housings will give your camera the best possible protection while being fully operable.

A Partial Listing, there are Dozens of Models to Fit Virtually any Camcorder Ever Made.

VC-PC For most JVC DV Camcorders.....	229.95	VC-XM For Canon GL-1.....	419.95
VC-PC For most Canon Elura and Sony DCR-PCR series.....	229.95	VC-2000 For Canon GL-2, Sony DCR-VX2000.....	449.95
VC-M For most Sony, Canon and Panasonic DV Camcorders.....	279.95	VC-150 For Sony DSR-PD150.....	389.95
VC-MC For Sony DCR-TRV950.....	339.95	VX-L For Canon XL-1/XL-1s.....	849.95



EWA MARINE

WATERPROOF HOUSINGS

Video Rain Capes

A sport capes for all popular video camcorders, they offer complete protection against rain, snow, moisture and dust. Ideal for use on boats and on the beach. Features include oversized glass optical port and mounting bracket (not for underwater usage). Fixed to the lens or fitted into the tripod screw, EWA Marine video capes are a clever alternative and offer reliable protection against the elements.

VC-M For camcorders up to 8" in length	794.95
VC-MC For camcorders 8-11" in length).....	84.95
VC-S Fits camcorders up to 13.5" long, includes bracket	99.95
VCL Fits full-size camcorders up to 17" long, includes positioning bracket	119.95
VC-XL For Canon XL-1	259.95



ACCESSORIES

195

EQUINOX Underwater Housings



Equinox underwater housings incorporate polyvinylchloride, a rugged, long-lasting material for the main body painted in an elaborate 5-step process with Porsche Guards Red for eye-catching beauty. They also feature all stainless steel hardware to prevent corrosion in a salt water environment; manual controls with double x-o-rings for ultimate safety from flooding; clear front and rear faceplates for visibility; safety catches on the face plates to prevent accidental opening underwater; contoured wings with lead handles and aircraft quick-release pins—another safety feature to prevent the loss of expensive video cameras in the event of an underwater emergency; and rubber feet for stability of this housing on the boat deck. With superior workmanship and materials—for dependable, long-lasting use—thousands of divers throughout the world have experienced 100% satisfaction and confidence using Equinox housings.

Housings Feature:

- ◆ Four or five manual controls including: Power on/off, Record start/stop, Zoom in/out, Photo still, White balance (ProPak 8)
- ◆ Clear front and rear faceplates for easy viewing of camera, eyepiece and/or LCD monitor
- ◆ Depth rated to 250 feet
- ◆ Neutral buoyancy
- ◆ Easy installation and removal of camera
- ◆ Color correction filter for salt water
- ◆ Wide angle lens
- ◆ All stainless steel hardware, spare parts kit
- ◆ 3-year Warranty

ProPak 6 Housings \$925.00 ea.

PP6DV951 For the Panasonic PV-DV951	PP6SE20MC For Canon Elura 20
PP6SPC115 For the Sony DCR-PC115	PP6SPC330 For the Sony DCR-PC330
PP6SDVM90U For the JVC GR-DVM90U	PP6TRV950 For the Sony DCR-TRV950
PP6DVD200 For the Sony DCR-DVD200	PP6CZR45 For the Canon ZR-40/45/50
PP6CZR60 For the Canon ZR-60	PP6CZR65 For the Canon ZR-65/70

ProPak 8 Housings \$1249.00 ea.

PP8GL1 For the Canon GL-1	PP8GL2 For the Canon GL-2
PP8VX2000 For Sony DCR-VX2000, PD570	PP8VX2000 For Sony DCR-VX2100, PD170
PP8DVX100 For Panasonic AG-DVX100	

ORDER & INFO. (212) 444-5010 • FAX: (212) 239-7770 (800) 947-7008
1-800-947-5525 • www.bhphotovideo.com



GATES

UNDERWATER HOUSINGS

ACCESSORIES

196

Housings for the Sony DCR-PC101/105/115/120/330

Small in size and big in results, these housings pack into petite luggage spaces, yet enables great images using the camera LCD as the viewfinder. Extremely durable, they are constructed of 'Bulletproof' machined aluminum, black type III 'hard' anodize finish, and sealed with a nickel-acetate process. They have 100% mechanical controls which makes them exceptionally dependable. There are no electronics than can fail in the humid salty air, no push buttons to get stuck and no batteries to worry about. Rated to 450' Gates reliability is a natural element of these tiny travelers. So when diving off in far off locales, they'll be ready when you are— 24 hours a day, 365 days a year— guaranteed for two years.



FEATURES

- ◆ Type II 'hard' anodize finish imparts a robust, military-grade finish on the housings. They will withstand abusive handling, scratches, and impacts – just about anything you can reasonably throw at it and still look great. Nickel Acetate seals the aluminum pores and makes the housing impervious to attack by salt water or other corrosive elements.
- ◆ Reliable fingertip controls are 100% mechanical — no sticky buttons, faulty electronics or dead batteries.
- ◆ LCD window is your big, built-in viewfinder for a clear, no-guesswork view of your shots. No need for extra external monitors to see your images while shooting.



- ◆ Quality optics means clarity, sharpness and no vignetting (cutoff dark corners) to spoil your images.

- ◆ Bayonet Port Mount for quick, easy change between Standard, Wide Angle and wet-connect Multi-Ports
- ◆ Internal Flip Filter provides quick, effortless use of the color correction filter. Blue or Green water versions available.

- ◆ Positive Lock stainless steel latches confirm your housing is sealed and secure.
- ◆ Accommodates all camcorder battery sizes for maximum shooting between re-charges.
- ◆ 2-year renewable warranty on all housings

Port Options

- ◆ Flat Port—Excellent for macro work, this port has a narrow field of view with no optical corrections. Allows full zoom through and use of diopters.
- ◆ Standard Port –1:1 port is optically corrected for underwater use. Allows full zoom through.
- ◆ Multi Port— Gates wet changeable lens system gives you macro to wide angle on the same dive.
- ◆ Fathom Imaging Wide Angle Port – this high resolution, distortion-free port has multiple glass elements for up to 90° field of view.
- ◆ Fathom Imaging Super Wide Angle Port – provides a 110° field of view and full zoom through capability for 1.5" macro.

Specifications

Controls (All Mechanical):

- Mode (On/Off/Mem)
- Record/Standby
- Photo • Zoom
- Auto Focus On/Off
- Internal 'Flip' Color Correction Filter

Dimensions:

7.5 x 6.5 x 7.5" LxHxW (12.5" with handles)

Material:

Machined aluminum, type III 'hard' anodize with nickel acetate seal

Weight: 4.8 lbs

Depth Rating: 450 feet / 137 meters

Batteries: Accepts all Sony batteries up to NP-QM91 and NP-FM91

Warranty: 2 Years



ONE HOUR FREE PARKING

AT 349 W. 34th STREET (with purchase of \$100 or more)

UNDERWATER HOUSINGS

Housings for the Sony DCR-TRV950 and DSR-PDX10

The Gates DCR-TRV950 and DSR-PDX10 housings feature a host of solid professional capabilities including: full auto to complete manual operation, reliable fingertip controls, optional 2.5" External Monitor, and over 6 hours of recording time. The 3-CCD system gives you clear, brilliant colors from the underwater realm like its grander cousins, but in a smaller, compact package. And only with a Gates can you switch from video to capturing full 1.3 Megapixel digital still photos to a Memory Stick.

FEATURES

- ◆ Type II 'hard' anodize finish imparts a robust, military-grade finish on the housings, allowing it to withstand abusive handling, scratches, and impacts – and still look great.
- ◆ Nickel Acetate seals the aluminum pores and makes the housing impervious to salt water or other corrosive elements.
- ◆ Reliable fingertip controls are 100% mechanical — no sticky buttons, faulty electronics or dead batteries.
- ◆ Quality optics means clarity, sharpness and no vignetting to spoil your images.
- ◆ Bayonet Port Mount for quick and easy change between Standard, Wide Angle and wet-connect Multi-Ports. Port options are the same as the compact DCR-PC series (see previous page).
- ◆ Internal Flip Filter provides quick, effortless use of the color correction filter. Blue or Green water versions available.
- ◆ Positive Lock stainless steel latches confirm your housing is sealed and secure.
- ◆ Accommodates all camcorder battery sizes
- ◆ Professional controls include exposure, white balance, shutter speed and manual focus
- ◆ You can switch between Video and "Memory" mode to capture full 1152 x 864 resolution still images on a Memory Stick
- ◆ Optional external 2.5" color monitor gives you a clear, view of your subjects
- ◆ 2-year renewable warranty on all housings



Shown with optional lights and monitor

Housings

Housing for the Sony DCR-PC101, 105, 115, 120, 330 with LCD open, with Standard Port.....	1820.00	Housing for the Sony DCR-TRV950 and DSR-PDX10 with Standard Dome Port.....	2335.00
Same as above except with Wide Angle Dome Port	2162.00	Same as above except with Wide Angle Dome Port	2677.00
Same as above except with Standard and Wide Angle Dome Ports	2278.00	Same as above except with Standard and Wide Angle Dome Ports	2792.00
Same as above except with Gates Multi-Port.....	2925.00	Same as above except with Gates Multi-Port.....	3440.00

Gates Paks

Includes Standard and Wide Angle Ports, NiteRider HID Pro Video Light Pack with battery bracket, Pelican Case with pluck foam liner, Port Cleaner/Polish Kit, Spare O-Ring Kit and Gates Drying Towel

For the Sony DCR-PC101, 105, 115, 120, 330 with LCD open.....	3916.00
For the Sony DCR-TRV950 and DSR-PDX10	4430.00

Specifications

Controls (All Mechanical):

- Mode (Off/Camera/Memory)
- Record/Standby
- Photo • Zoom
- Auto/Manual Focus
- Exposure Dial/Set
- Shutter Speed • Program AE
- White Balance Mode/Set
- Internal 'Flip' Color Correction Filter

Dimensions:

11 x 6 x 6" LxHxW (11.5" with handles)

Material:

Machined aluminum, type III 'hard' anodize with nickel acetate seal

Weight: 7 lbs

Depth Rating: 450 feet / 137 meters

Batteries: Accepts all Sony batteries up to NP-QM91 and NP-FM91

GATES

UNDERWATER HOUSINGS

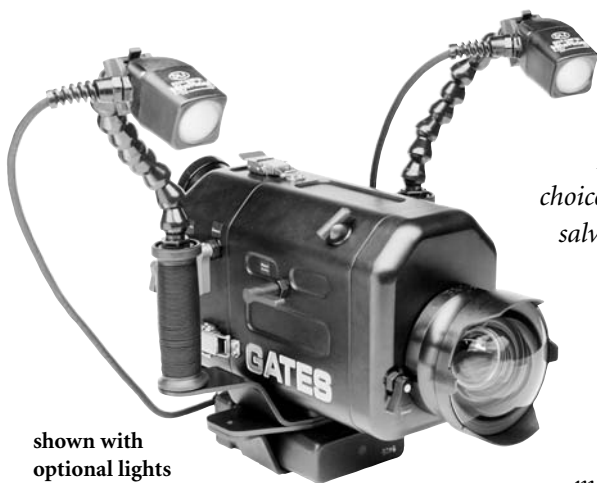

shown with optional lights

Housings for the Sony DCR-VX2000/2100 and DSR-PD150/170

With improved controls, depth rating of 450-feet, and Fathom Imaging high performance optics, these housings continue to be the choice of professional videographers, marine researchers, commercial divers, salvage operators, and the US military. They know it will stand up to their demanding needs day after day, year after year, with proven, reliable results.

Made of "bulletproof" machined-aluminum, anodized and urethane sealed, these housings are the perfect compliment to the DCR-VX2000/2100 and DSR-PD150/170 3-CCD camcorders. Vertically stable, they provide total control of camera functions with reliable mechanical controls, crystal-clear optics, built-in magnified viewfinder, and internal color correction "flip" filter.

FEATURES

- ◆ Type II 'hard' anodize finish gives a robust, military-grade finish on the housing, allowing them to withstand abusive handling, scratches, and impact – and still look great.
- ◆ Nickel Acetate seals the aluminum pores and makes the housing impervious to salt water or other corrosive elements.
- ◆ Reliable fingertip controls are 100% mechanical — no sticky buttons, faulty electronics or dead batteries.
- ◆ Interchangeable ports for quick and easy switching between Flat, Standard and Wide Angle
- ◆ Internal Flip Filter provides quick, effortless use of the color correction filter. Blue or Green water versions available.
- ◆ Positive Lock stainless steel latches confirm your housing is sealed and secure.
- ◆ Accommodates all camcorder battery sizes
- ◆ Reversible handles let you find the best balance and position for your hands on the controls. Handles can be removed for storage and travel.
- ◆ Switch between Video and "Memory" mode to capture full 640 x 480 resolution still images on a Memory Stick
- ◆ Optional external 2.5-inch color monitor gives you a clear, view of your subjects
- ◆ 2-year renewable warranty on all housings

Port Options

- Flat Port—Excellent for macro work, this port has a narrow field of view with no optical corrections. Allows full zoom through and use of diopters.
- Standard Port—This port is available for use with 3rd party lenses like Century Optics' 16:9 Anamorphic Converter.
- Fathom Imaging Wide Angle Port – this high resolution, distortion-free port has multiple glass elements for up to 90° field of view.
- Fathom Imaging Super Wide Angle Port – provides a 110° field of view and full zoom through capability for 1.5" macro.

Housings

Housing with Wide Angle Dome Port.....	2985.00
Housing with Super Wide Angle Lens	6646.00
Housing with Wide Angle Dome Port, NiteRider HID Pro Video Light Pack with battery bracket, Pelican Case with pluck foam liner, Port Cleaner/Polishing Kit, Spare O-Ring Kit, Gates Drying Towel	4623.00
Same as above except with Super Wide Lens	9369.00

Specifications

Controls (All Mechanical):

- Mode (On/Off/Mem)
- Record/Standby
- Photo • Zoom
- Auto Focus On/Off
- Internal 'Flip' Color Correction Filter

Dimensions:

7.5 x 6.5 x 7.5" LxHxW (12.5" with handles)

Material:

Machined aluminum, type III 'hard' anodize with nickel acetate seal

Weight: 4.8 lbs

Depth Rating: 450 feet / 137 meters

Batteries: Accepts all Sony batteries up to NP-QM91 and NP-FM91

Warranty: 2 Years



For Any Inquiries Regarding Your Order, Call Our Customer Service:
(800) 221-5743 • (212) 239-7765 • FAX: (800) 947-2215 • (212) 239-7549

GATES

UNDERWATER HOUSINGS

Housing for the Canon XL-1/XL-1s

Designed specifically for the Canon XL-1 and XL-1s, this housing design includes an external viewfinder and support for both the 3x and 16x lenses. In addition, NTSC and PAL versions are both supported in this housing for true global capability, and a 2.5" color external monitor is included for clear, no guesswork images.

Housing with 3x Lens Port (For Wide Shots, this port is designed specifically for the Canon 3x lens)3950.00

Housing with 16x Lens Port (for close up and macro work, this port supports the Canon 16x lens. The port allows filters and/or diopter elements to be used395.00

Housing with 3x and 16x Lens Ports4150.00

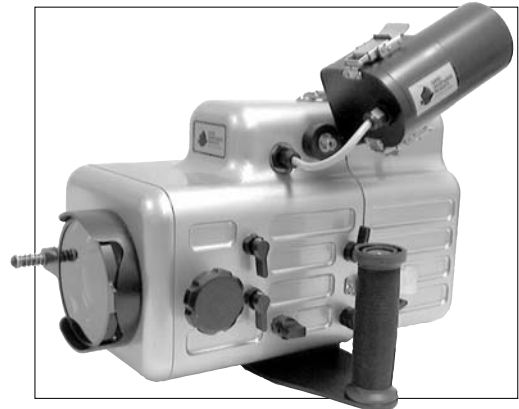

ACCESSORIES

199



Housing for the JVC GR-HD1

Breaking new ground in underwater video, the Gates HD1 housing is the first high definition system designed specifically for the JVC GR-HD1 Hi-Def camcorder. Professionals will appreciate access to key functions like white balance, shutter speed, manual focus and iris. Several optics are available for the HD1, including the WP35 wide angle port designed by Fathom Imaging for high resolution, distortion free images. Of course, Gates reliability is inherent in the HD1, and will serve your demanding needs day after day, year after year, with proven, reliable results.

Optional Underwater Accessories

NiteRider HID Pro

- Dual 10w HID light heads – 20w combined – equivalent to 80w halogen
- 4 Amp-hour NiMH battery pack
- Extended 1.9 hr burn time
- Big 90° beam angle
- Daylight-balanced 6000°K color temperature
- Fast 3.5 hr international smart charger
- Optional battery mounts for Gates and other housings
- Lifetime manufacturers warranty
- Flexible system – reconfigure for hands free dive lights

NiteRider HID Pro Video Light1523.00

NiteRider HID Pro Video Light with Battery Mount Bracket1638.00

EM253 External Monitor

Take the guesswork out of your images with a big 2.5" color active matrix LCD display on the Gates External Monitor. Framing, focus and other settings are easy to see (even in bright sunlight), so your results are easy, too. Available in NTSC or PAL versions.

- ◆ Never accidentally run down your batteries. With the power-on auto sense circuitry, the monitor is on when your camera is on, and automatically off when not in use.
- ◆ Swivel mount allows the monitor to swivel in various directions for best viewing angle
- ◆ "Bulletproof", the monitor is machined from 6061 T6 aluminum, finished in di-chromate anodize and silver urethane.
- ◆ Depth rated to 450 feet, it comes with Gates 2-year warranty.



Submersible Microphone

Capture the sounds of the underwater world – whale song, reef clatter, or your buddy's bubbles – with the submersible microphone. Compatible with Sony DCR-PC101/105/115/120/330/TRV950

ORDER & INFO. (212) 444-5010 • FAX: (212) 239-7770 (800) 947-7008
1-800-947-5525 • www.bhphotovideo.com

