





The Professional Audio

SourceBook

Section 2

Processors

Alesis	198-206
Antares	207-209
Aphex	210-217
ART	218-223
Avalon	224-232
Behringer	233-243
dbx	244-259
Eventide	260-261
Focusrite	262-274
HHB	275
Joemeek	276-281
Lexicon	282-289
Presonus	290-299
Rane	300-315
Samson	316-321
Symetrix	322-325
TC Electronic	326-337
TC Helicon	338-341
TL Audio	342-344
True Systems	345
Waves	346-347
Yamaha	348-351

ALESIS

INEKO

PROCESSORS

198



Stereo Effects Processor

Ineko is a unique table-top, stereo effects processor that doesn't require an engineering degree to operate, or a fat recording contract to afford. A powerful, professional-quality tool designed for music recording, DJ and dance applications, it is exceptionally user friendly with a very intuitive, self-explanatory interface. No complicated menus or difficult to use functions. Just three simple knobs to control 48 dramatic, user-adjustable effects, including reverbs, filters and delays. So simple, even novices can master it right out of the box. With its metallic gun-gray, industrial design and over-the-top sounds, Ineko redefines effects processing by providing top-quality, user-friendly, real-time effects at an unbeatable price.

- ◆ Designed for music recording, DJ and dance applications, as well as recording and live performance, Ineko gives the user the power to control real-time effects via a simple intuitive user interface.
- ◆ The uncomplicated faceplate sports a 6 x 8 LED grid/program display which shows the 48 high-quality reverbs and delays, traditional effects such as chorus, vibrato, flanger, and phasers.
- ◆ Also incorporates an arsenal of unique effects, from sub-harmonic synthesizer, fuzz, vibrowobbel, and formant-filter, to frequency-shifter, band-limiter, decimator and vocoder.
- ◆ Three large dedicated knobs provide direct real-time control over effects parameters – the three available parameters for each effect are written underneath the effect name on the front panel.
- ◆ Effects programs are grouped by category and are easily selected along the matrix using the simple down and across buttons.
- ◆ Bypass button to engage or disengage signal effects during use.
- ◆ 24-bit converters
- ◆ 1/4" stereo inputs and outputs
- ◆ Input trim control with a signal present LED indicator

AKIRA

Programmable Stereo Multi-Effects Processor



The Akira is a multi-effects processor that is ideal for studio, live performance, and sound reinforcement applications. Affordably priced for entry- and mid-level recording enthusiast and musician, the Akira has sounds that set it apart from anything else on the market. In addition, its X, Y, and Z parameter knobs allow real-time, playable control over program parameters, making Akira much more than a "set-and-forget" rack mount signal processor. Akira features 24-bit A-D and D-A conversion, stereo analog I/O on balanced TRS 1/4" jacks, and an internal switching power supply that works on 90-230v AC. There's also MIDI I/O for program changes and continuous controller transmit and receive, for additional real-time control over the effects. Housed in a 19" rack-mount enclosure (1RU) high, Akira has an easy-to-understand interface, making it ideal for its intended audience.

- ◆ Two channel, 24-bit A/D-D/A, 28-bit internal processing, 48kHz sample rate
- ◆ 100 programs - reverbs, delays, pitch mod, filters, and special effects
- ◆ MIDI I/O, balanced 1/4" TRS analog I/O, +4dBu/-10dBV



EQUIPMENT LEASING AVAILABLE



Motion-Controlled Effects Processor

Connect the airFX to any line-level sound source and speaker system. Then move your hand, or any other body part through the invisible 3D sphere formed by Alesis' patented Axyz technology. You can move any direction; up or down, right or left, or in or out, to twist any sound in an infinite number of ways. The slightest movement of your hand tweaks the tones of the AirFX and turns your tunes inside out.

Modify the sound of any audio from CDs, LPs, tape, computer - even live instruments and vocals with 50 high-quality, stunning filters and effects from vinyl to vocoder, flanging, and virtually anything and everything in-between.

airFX and airSynth both feature:

- ◆ Incorporated into the airFX and airSynth space-age domes are four infrared sensors that generate a halo of light over the instrument. Known as the Axyz (pronounced ax-is) system, this revolutionary technology gives you three planes of control over internal effects:
X (left to right), Y (front to back) and Z (up and down). Other effect controllers provide only X/Y coverage.
- ◆ High-quality sounds and effects:
 - airFX: 50 filters and effects, including percussive sounds
 - airSynth: 50 synthesized sounds and sound effects, including percussive and legato noises.
- ◆ They feature a frequency range of 20Hz-20kHz, 24-bit converters and ship with a 9-volt AC power supply.
- ◆ A threaded socket on their base allows you to mount them on a mic stand for ease-of-use in club and studio applications.
- ◆ Incorporating the same futuristic design airSynth can be integrated with airFX in a singular system via stereo RCA inputs and outputs without using an external mixer.
- ◆ Their simple user interface consists of a single knob, which is used to select, engage, bypass, freeze and release a given sound, and an LED that indicates the current program.

AIRSYNTH

Motion-Controlled Effects Processor and Sound Generator

airSynth produces dramatic synthesized sounds and sound effects when you pass your hand over the invisible 3D sphere above it. Alesis' patented Axyz technology lets you control up to five sound variables simultaneously by moving your hand left to right, forward and backward, or up and down over the product, making airSynth easy and intuitive to use. The dramatic sound set and unique user interface make airSynth ideal for use in live performances, DJ applications, music postproduction, and on-air broadcast applications.

And while it employs the same technology and simple user interface, unlike the effects processing airFX, the airSynth is a true sound-generating product that features a broad range of sound effects and synthesized noises providing an altogether different and complimentary range of options. The unique airSynth sound-set includes 50 staccato, percussive, legato continuous pads, drum sounds and sounds that emulate things in nature.



ALESIS

MODFX LINE

PROCESSORS

200

14 Unique Performance Effect Boxes

The ModFX line is a family of performance effects boxes that includes 14 individual units, each one providing a different set of sound effects and signal processing. Of particular interest to musicians, DJs, and recordists is the extremely versatile modulation section on several of the boxes, providing unprecedented control over the sound of the effects, including the ability to sync modulation to incoming music tempo. Every box in the ModFX line digitally processes analog stereo signals and maintains a uniform, friendly, uncomplicated user interface. Keyboardists, guitarists, and any other studio or live performance artists will find the selection and variety of the ModFX line well suited to a wide variety of musical applications.

Each box- designed with internal 28-bit digital processing - allows you to connect to multiple units within the family via the link ports (in and out) located on either side of each box. These links allow the units to pass digital audio, word clock and power between ModFX line family members. Analog I/O is provided via four separate 1/4" unbalanced connectors, and each unit comes with an AC power supply. A fifth 1/4" connector allows an external footswitch to control the Bypass function. Each unit is sized to fit a 1/3 rack space; an optional rack mount adapter is available.

Fidelity X

A "communications simulator" that simulates tape, vinyl, radio, megaphone, telephone, and digital. Features include the 'Year' parameter that defines the "age" or "vintage"; a 'Mono' button that combines the input stereo signal into a mono signal and feeds it through the processor; a 'Quality' knob that controls the fidelity; a 'Drive' knob that adjusts the amount of distortion; the 'Tone' knob which filters the output providing a bass or treble boost; and the 'Mix' knob that adjusts the amount of "wet" (affected) signal compared to the "dry" (unaffected) signal.



Bitrman

Here's an extraordinary effects box comprised of compression, distortion, dual phasing and a fourth selected effect that can either be a comb, decimator, bit reducer, frequency modulator, ring modulator, or frequency shift. The four effects can be configured multiple ways by adjusting the 'Configure' parameter.



PhIngr

Here's a flanger box with an amazing modulation section. All of the modulation waveforms can be beat synchronized to the input music. Some of the features include the 'Type' switch that describes the



type of the flanging effect; the 'Beat Tap' switch that enables the user to control the tempo used in the beat synchronizer; the 'Center' knob that controls the range of the frequencies affected; the 'Rate' knob that controls the speed of the oscillations; and the 'Depth' knob, controlling the amount of modulation.

Vertigo

This world-class Leslie simulator re-creates the vintage sound of the original and can produce great new variations on the classic sound. Vertigo sports Fast, Slow, and Idle buttons to set the speed of the rotating horn simulation. The 'Mix'

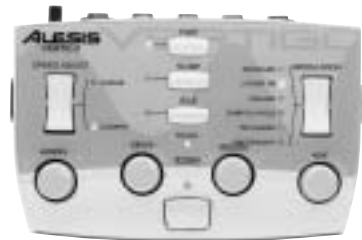

knob will adjust the amount of "wet" signal compared to the "dry" signal.

Ampliton

This unit combines a tremolo with an autopan. The low frequency oscillator (LFO) of both the tremolo and the autopan can be independently set according to your sound desires. The LFO can be set to triangle, square, sample and hold, triggered, and "uncertainty" waveforms. Each LFO can be beat synchronized to the music, and a 'Beat Tap' button enables the user to adjust the tempo.



Nastify

Like its name implies, this is a distortion effect box with attitude and edge. Six different styles of distortion can be selected: Warmth, Fuzz, Distortion, Thick, Chunk, and Stellar. Knobs control drive, tone, and the amount of output gain.



ONE HOUR FREE PARKING

AT 349 W. 34th STREET (with purchase of \$100 or more)

Formantz

Formants are filters that emulate the sounds of speech; Formantz is an advanced filter modeling box that will leave you speechless. The filter can be modulated by either triangle, sample and hold, triggered, "uncertainty", or "pattern" waveforms, and all of the modulation waveforms can be beat synchronized to the input music. The 'Frequency' knob controls the center frequency of the filter; The 'Modify' knob varies the selected 'Type'.



Philtre

Meet the ModFX line's resonant filter. You can select either Low Pass, High Pass, Band Pass, Low Pass Alias or any combination as filter types. Five different modulation waveforms can be selected, each of which can be beat synchronized. The 'Reset Mod' button will reset the phase of the LFO; the 'Steep' button switches between 4- and 6-pole filters.

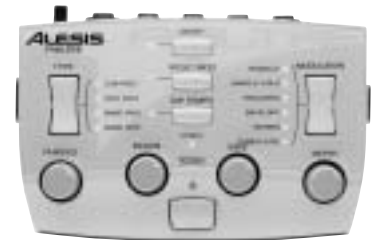

Faze

This is a phasor effect box loaded with features and controls including the 'Type' of phasor that is selected from options including Deep Mono, Dual Mono, Contrary Stereo, Asynchronous Stereo, and Liquid Metal. Five different modulation waveforms



can be selected, each of which can be beat synchronized with the aid of the 'Beat Tap' button.

Smashup

Yes, it's a compressor. The user can select from five different type of compression: Classic, Opto, De-Ess, Pump, and Fat. The 'Threshold' controls the threshold level; The 'Attack' and 'Release' control the attack and release values for the

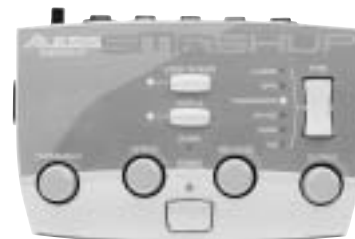

compressor. The 'Output' parameter controls the output gain.

Lymitre

A remarkable two-band limiter with great controls including the 'Look Ahead' switch, enabling a look-ahead peak limiter; the 'sizzle' switch that adds post-limiting brightness; and the 'Crossover' knob that enables the user to set the frequency that separates the two bands.

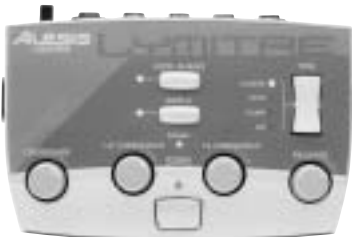

Koruz

What's a family of performance effect products without a chorus effect box? The chorus effect can be modulated by triangle, hyper-triangle, square, sample and hold, "uncertainty", or triggered LFO shapes. The 'Depth' knob controls the amount of modulation.

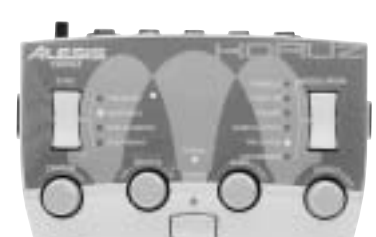

Metavox

This unit is a vocoder where the user can choose four different types of internal synthesizers (Saw, Rectified Saw, Square, And Noise). The synthesizer is modulated by one of five sources (triangle, sample and hold, triggered, "uncertainty", and tracking)



that can all be beat synchronized with the aid of the 'Beat Tap' button. There's also a control that allows for setting the frequency of the internal synthesizer. Another great feature of Metavox is that it also allows an external synthesis source to be input and voice-modulated.

Spectron

This unit adds bass and treble harmonics to a signal. The user can define the frequency and volume of the harmonic generator for the bass and treble synthesizers. Controls can also eliminate the original signal from the output and generate only the synthesized harmonics.



The 'Bass Limiter' provides the user with a means to limit the strength of the bass synthesizer.

ALESIS

MICROVERB 4

Multi-Effects Processor

An easy-to-use, programmable reverb and effects unit, the MicroVerb4 provides a wide variety of great-sounding, easy-



to-use effects for small studios, engineers and performing musicians. The key to MicroVerb 4's power is in its simplicity. It offers 200 programs that include everything from high-quality reverb, delay, chorus and flange to exciting multi-effects and more. To customize your programs, two front panel knobs allow for quick, easy, user-storable edits, or use its MIDI inputs for control over program changes and modulation. You can then save your edited programs in the 100-space user program bank.

PROCESSORS

202

FEATURES

- ◆ 200 programs (100 preset, 100 user-storable) of Reverbs (Hall, Room, Plate), Chorus/Flange, Delay (Mono, Stereo, Ping Pong and Multi-Tap) and Pitch Shift as well as multi-effect and dual mono send algorithms.
- ◆ Each Program has two parameters which can be adjusted via the dedicated Edit A and Edit B controls. Depending on the type of Program selected, these might alter Reverb Decay, Chorus Depth, etc.

PROGRAMS	EFFECT	EDIT A	EDIT B
01 - 09	HALL	DECAY	WET DRY
10 - 19	ROOM	DECAY	WET DRY
20 - 29	PLATE	DECAY	WET DRY
30 - 42	CHORUS/FLANGE	DEPTH	DEPTH
43 - 52	DELAY	TIME	FEEDBACK
53 - 69	PITCH SHIFT	SEM/SHFT L	PITCH/SHFT R
70 - 89	MULTI-EFFECT	DECAY	RATE/TIME
90 - 99	DUAL SEND	DECAY	RATE/TIME

The Parameter Chart shows you what effect type is assigned to various groups of Programs – it also shows the function of the Edit A and Edit B controls

Front Panel

- ◆ Dedicated input and output level controls
- ◆ Mix control adjusts the balance between the dry and wet (effected) signals
- ◆ Dual 4-segment LED input level meters
- ◆ The multi-purpose LED display typically shows the currently selected Program but will also display the MIDI channel or parameter values
- ◆ The rotary Value Encoder is used to select Programs and to change the MIDI channel
- ◆ Bank/MIDI Button lets you quickly change between the Factory and User program banks as well as select a MIDI channel

Inputs and Outputs

- ◆ Left and right unbalanced 1/4" inputs and outputs accommodate four different configurations: Mono In/Out, Mono In/Stereo Out, Stereo In/Out and Dual Mono In/Out
- ◆ MIDI In and Out/Thru connectors allow you to perform several MIDI functions including Program Changes, send/receive Sys-Ex data and realtime control of up to two parameters simultaneously
- ◆ 1/4" stereo phone jack lets you connect one or two momentary footswitches – a single footswitch functions as an effect bypass. Add a second footswitch via insert cable to use as a control switch for tap tempo, or to control Leslie speed (slow/fast) – if the control footswitch is held down and audio is played into the inputs, these impulses will be used to set the delay time.

NANOVERB

Preset Digital Reverb and Effects Processor

The NanoVerb offers 16 of Alesis' best preset effects algorithms in a compact, easy-to-



use and incredibly affordable package. You'll enjoy its lush hall, plate and room reverbs, rich true stereo chorus, flange, delay, rotary speaker emulation and useful multi-effects.

- ◆ 18-bit A/D and D/A converters with a 20-bit internal processor ensure the sonic quality that allows you to use it for any effects application from guitar rigs to studio recording.
- ◆ Power/input and dual-color signal input/clip LEDs
- ◆ Front panel adjust knob allows you to tweak NanoVerb's great-sounding programs until they're just right for your music, while the input/output levels and Mix controls ensure proper effect levels for a wide variety of applications.
- ◆ Stereo 1/4" inputs and outputs
- ◆ Ultra-compact 1/3 rack-space package



Fully Programmable Multi-effects for Live and Studio

The MidiVerb 4 is the perfect effects processor for professional project studios and musicians



who require an affordable solution for fully-programmable, high-fidelity effects. Its excellent effects algorithms produce dense, natural reverb, rich chorus, flange, delay, pitch effects and up to three simultaneous multi-effects. MidiVerb 4's thirty-two effects algorithms give you a complete arsenal of fully programmable effects, many using true stereo parallel processing. You can take advantage of the 256 powerful programs with 128 spaces for user-created effects. With its easy-to-use graphic interface, programming your own effects is a snap. And by using MidiVerb 4's MIDI controller routing and assignable footswitch input, you'll have complete creative control over every aspect of your sound.

FEATURES

Inputs & Outputs

- ◆ Left and right unbalanced 1/4" inputs/outputs with 18-bit A/D and D/A converters and 24-bit internal processing for a 20Hz-20kHz bandwidth and 90dB dynamic range, making it ideal for digital recording.

Effects

- ◆ 256 programs (128 Preset/128 User-storable) include single stereo, multi-effect and dual mono effects configurations based on 32 different algorithms
- ◆ Reverb: Concert Hall, Real Room, Ambience, Plate, Nonlinear
- ◆ Delay (1299 ms of total delay memory): Mono Delay, Stereo Delay, Ping Pong Delay, Multi Tap Delay and a BPM Mono Delay which responds to MIDI clock
- ◆ Pitch: Stereo Chorus, Quad Chorus, Stereo Flange, Stereo Pitch Shifter
- ◆ Special: Auto Pan
- ◆ Double: Real Room+Delay, Real Room+Chorus, Real Room+Flange
- ◆ Dual Mono: Delay/Delay, Chorus/Chorus, Flange/Flange, Pitch/Pitch, Chorus/Delay, Flange/Delay, Pitch/Delay
- ◆ Multi Chain: Delay->Real Room, Chorus->Real Room, Flange->Real Room, Lezlie->Room, Real Room->Flange, Chorus->Delay->Room, Flange->Delay->Room
- ◆ Display is divided into 5 sections: Program Number, Bank (Preset, User), Program Name (up to 8 characters), Configuration (Stereo or Dual effect), Level Meters (Peak-style inputs meters).

Editing

- ◆ Access up to four edit pages per preset – the currently selected page will be indicated in the display by a box around its number
- ◆ Each edit page contains up to four parameters accessed via the A, B, C and D buttons. Currently selected parameter can be adjusted by the value knob.

External Control Functions

- ◆ MIDI controller routing and an assignable 1/4" footswitch input for flexible control on stage
- ◆ Up to two effect parameters, pre-configured in each preset, can also be modulated via MIDI – the modulation range for each parameter can be set

Conveniences

- ◆ Automatic Input Level Sensing— simply press and hold the Input and Output buttons simultaneously for five seconds or longer and the Auto Input function will automatically optimize the input level
- ◆ Once you have accessed Edit mode, if you hold any of the parameter buttons (A, B, C or D) for more than one second, the upper display will provide a detailed description of the selected parameter

PICO VERB

Ultra-affordable Digital Multi-Effects Unit

The PicoVerb is great sounding reverb and effects unit designed for the budget-conscious musician or recording enthusiast. The 16 multi-effects presets include chorus, flange, delay, chorus/reverb, rotary speaker simulator, and more. Super-compact, expertly designed and superbly priced.



- ◆ Perfect for studio and sound reinforcement applications
- ◆ Stereo, 24-bit A/D-D/A, 28-bit internal processing, 48kHz sample rate
- ◆ 16 Presets including Halls, Rooms, Plates, Chorus, Flange, Delay, Lezlie
- ◆ Unbalanced 1/4" analog I/O, -10dBV
- ◆ 1/4" rack wide

ALESIS

CLX-440

PROCESSORS

204

Compressor/Limiter/Expander

The CLX-440 is a full-featured compressor/limiter/expander that combines separate compression and expansion sections for each stereo channel, with "look-ahead" capability, side-chain and "key" functions,



continuously-variable soft/hard knee and peak/RMS controls. Two sets of front-panel meters provide confirmation of input, output, compression and expansion activity. Special algorithms provide a broad range of dynamics options—from gentle to aggressive—to meet the requirements of live sound and studio production. CLX-440 also features a side chain I/O that allows you to insert an external EQ such as the PEQ-450, into the dynamic side chain. A special "look-ahead" function allows dynamic processing to start before the signal is present, by delaying the audio path by approximately one millisecond.

- ◆ Dual stereo architecture allows processing of 2 mono or 2 stereo signals, up to 4 channels of signal processing
- ◆ Sidechain and key inputs and outputs
- ◆ Separate compression and expansion sections for each stereo channel
- ◆ Continuously-variable soft/hard knee and peak/RMS controls
- ◆ Two sets of front-panel meters provide confirmation of input, output, compression and expansion activity

400 SERIES PROCESSORS

Designed for use in studio, live-sound, installation and broadcast applications, the 400 Series signal processing line features a striking industrial design and unique "dual-stereo" processing to provide highly flexible and very powerful sound shaping capabilities for the audio professional. Rather than relying on complex menus and complicated interfaces, each 400 series product is designed to perform a dedicated function extremely well, using the highest quality components and familiar, analog-style controls. Additionally, they feature four-channel "dual-stereo" processing to give users more channels of processing at very affordable prices.

Hidden beneath their aluminum-extruded chassis is a tremendous amount of processing horsepower and a unique routing scheme. Unlike standard 2-channel processing products which traditionally "link" both channels for a simulated stereo operation, the CLX-440 allows two true stereo programs to be processed simultaneously, and the PEQ-450 allows dual-stereo 5-band or "chained" 10-band dual-stereo operation.

Dual-stereo capability is very useful in studio and live sound applications where multiple channels of audio need to be processed simultaneously.

PEQ-450 Dual Stereo Parametric Equalizer



The PEQ-450 is a dual-stereo 5-band, fully parametric equalizer with 20Hz to 20kHz EQ control, +/- 18dB boost/cut controls, continuously-variable Q, high and low shelving, high- and low-pass filters and

input/output metering. The PEQ-450 also includes qualities offered in more expensive parametric equalizers such as high quality pots and switches, separate frequency gain and Q controls for each band, plus high-pass and low-pass filters. The unique "chain" mode allows all 10 bands of EQ to be used in tandem to process two stereo signals simultaneously. An internal power supply and balanced 1/4" TRS input and output jacks complement the impressive features of both two-rack products.

- ◆ Dual 5-band parametric equalizer with frequency, gain, and Q for each band plus high- and low-pass filters and high and low shelving.
- ◆ Up to four channel processing: dual mono, dual stereo or "CHAIN" mode allows 10 bands of EQ to be applied to a stereo signal
- ◆ Two sets of dedicated controls for all EQ functions
- ◆ Front-panel meters indicated input and output activity



For Any Inquiries Regarding Your Order, Call Our Customer Service:
(800) 221-5743 • (212) 239-7765 • FAX: (800) 947-2215 • (212) 239-7549

RMS/Peak Dual Channel Compressor/Limiter with Gate

The 3630 is an affordable single rack space dynamics processor that provides two independent full-featured



channels of compression, limiting and gating, suitable for any application from subtle gain control to in-your-face punch. The compression section features variable Ratio, Threshold, Attack and Release controls as well as switchable RMS and Peak detection circuitry and Hard and Soft knee compression curves. The two fully independent gates feature variable threshold and rate controls to easily silence ambient noise. You can use the 3630 as an independent dual-channel compressor, with separate controls for each channel or push the Link button to strap the left and right channels together for stereo processing. Also features 1/4" inputs and outputs, precise signal metering and a sidechain insert for keying or ducking effects.

FEATURES

- ◆ Two discrete channels with identical controls and I/O provide stereo or dual mono operation – you can use each of the two channels independently, or you can strap both channels together, using the Link button, for stereo operation with both channels being controlled by channel A

Compression

- ◆ Each channel features a Threshold control variable from -40dBu to +20dBu and a Ratio control variable from 1:1 to ∞:1 (limiting)
- ◆ Selectable Peak or RMS response lets you decide whether the sidechain circuit reacts to signal peaks and potential clipping or average signal levels
- ◆ When using the Peak response setting, you are able to adjust the Attack Time from 0.1ms - 200ms and the Release Time from 50ms - 3S – when the RMS response setting is used, attack and release times are program dependent
- ◆ The selectable Knee button provides a choice of the more severe “Hard knee” curve in which compression only kicks in when the input level reaches the threshold or a gentler “Soft knee” curve in which the compression ratio gradually increases up until the input level reaches the threshold
- ◆ Bypass switches make it easy to compare the processed and unprocessed signals

Noise Gate

- ◆ The Threshold control (variable from continuously open to 10dBu) determines the level that a signal needs to exceed before the gate will open
- ◆ The Rate control, variable from 20ms - 2S, determines how long it takes for the gate to fade smoothly from the open to closed setting
- ◆ A pair of LEDs indicate whether the gate is open or closed

Output and Metering

- ◆ An Output level control variable ± 20 dB is available for making up gain that is lost due to compression
- ◆ 12-segment LEDs are provided for gain reduction metering (-1 to -30 dB range)
- ◆ 12-segment LED meters are switchable to show either input or output levels (-30 to +6 dB range)

NANO COMPRESSOR

Stereo Compression Unit
In A One-third
Rackspace Package



- ◆ A single set of controls provides full-featured dynamics processing of left and right channels simultaneously
- ◆ Front-panel controls include Ratio, Threshold, Attack, Release and Output Level as well as a Bypass button
- ◆ Selectable Peak and RMS compression input detection as well as hard and soft knee compression curves
- ◆ Indicators include a 6-segment switchable input/output meter and a 6-segment gain reduction meter
- ◆ Rear panel connections include unbalanced 1/4" stereo inputs and outputs as well as a 1/4" TRS sidechain insert that allows you to interface with other devices for ducking and de-essing

Rear Panel

- ◆ 1/4" unbalanced inputs and outputs are switchable for +4 dBu or -10dBV operation
- ◆ 1/4" TRS side chain I/O enable you to: Insert EQs for frequency-selective dynamics control such as de-essing or, Key (trigger) dynamics control from an external audio source i.e., using a voice-over track to lower the volume of background music (known as ducking)

ALESIS

DEQ-224/DEQ-230

Programmable Dual 1/3-Octave Graphic Digital EQs



Unlike so many EQs on the market today, the DEQ-230

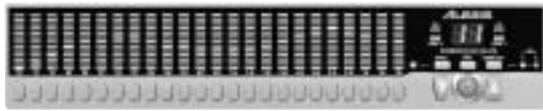

has a friendly, intuitive nature, making it one of the easiest to use, manipulate and control. With a sleek industrial design including over 800 individual LEDs to give a richly detailed view of EQ curves, the DEQ-230 is a clear standout in the world of graphic equalization. Plus its feature set is well suited for profes-

sional studio applications, while its very affordable price also makes it attractive to the recording hobbyist or performing musician. The DEQ-224 delivers the same digital performance and quality as the DEQ-230 in a highly compact package. The DEQ224's half-rack form factor and powerful EQ capabilities make it ideal for professional and home studios with limited rack space, as well as the perfect addition to any gig bag.

DEQ-230

Taking advantage of its internal digital signal processing and unique user interface, the DEQ-230 has the ability to store and recall 25 preset and 25 user-defined curves, as well as a single bypass button that affects both channels simultaneously. Sized to fit a single rack mount chassis, it includes 1/4" unbalanced analog I/O and an external AC power supply.

DEQ224

Easy-to-use and understand interface, with 30 preset EQ and 30 user-recallable EQ curves. Two independent channels of EQ: 24-bands, ± 12 dB resolution. 13-LED resolution of cut/boost per frequency band. Individual Signal and Clip indicators per channel. Analog I/O using 1/4" balanced TRS connectors. Bypass and Channel A-B link controls.

DEQ-230D/DEQ830

Programmable Dual 1/3-Octave Graphic Digital EQs



Based on the extraordinary technology of the popular DEQ-230, these two programmable rackmount EQs give recording engineers and live sound professionals an expanded feature set, enhanced 24-bit sound quality, and more flexible routing options than any other EQ in their class—at breakthrough prices.

DEQ830

The DEQ-830 boasts eight independent programmable 1/3-octave graphic equalizers in an amazingly compact 1U rackmount design. Connections include eight balanced 1/4" TRS analog I/O and eight channels of ADAT Optical digital I/O, making it perfect for a range of modern recording applications. It also features 100 user-customizable EQ programs, 50 template "curves" for rapid setup, and +4dBu/-10dBV switchable operation—allowing a high degree of user customization. Add an ultra-intuitive user interface and MIDI I/O, and the DEQ-830 is everything a high-end programmable EQ should be, without the price tag.

DEQ230D

For those who don't need eight channels of processing, the DEQ-230D is a dual-channel 1/3-octave programmable EQ with expanded I/O and more features than the acclaimed DEQ230, including two channels of fully balanced 1/4" TRS analog I/O, switchable +4dBu/-10dBV operation, S/PDIF input and MIDI I/O for use in a range of stage and studio applications. Additionally, 30 Preset and 30 User programs and an extremely intuitive user interface provide for fast sonic tweaks and various customized settings

Auto-Tune Intonation Processor



Back in 1998, Antares introduced the ATR-1 and made the unlikely claim of “perfect pitch in a box” a solid reality. It corrected the pitch of vocals or solo instruments, in real time, without distortion or artifacts, while preserving all of the expressive nuance of the original performance. Since then, thousands of ATR-1s have found their way into touring racks, live performance rigs, and recording studios of artists and producers like Cher, Everclear, Al Schmitt and many, many more. Preserving the great sound quality and ease of use of the ATR-1, the ATR-1a adds a Bass Mode (for correcting the pitch of low bass range instruments) and the innovative Make Scale From MIDI function which allows the ATR-1a to automatically create a custom target scale for any melody.

FEATURES

The Right Note

A key requirement for effective pitch correction is the ability to accurately specify the right notes to correct to. The ATR-1a gives you a variety of choices to ensure that its output is always what you want. The basic tool for target pitch identification is the Scale:

- ◆ The scale is a list of the notes that the input notes are corrected to
- ◆ Factory Programs are provided for chromatic and standard diatonic scales as well as the ability to use the Scale screen to program custom scales
- ◆ Individual notes can be bypassed. When the input pitch is near a bypassed note, the input is passed through with no correction.
- ◆ For more flexibility, the MIDI Note Mode allows you to specify scales in real time via a MIDI keyboard or sequencer – you can even specify the exact melody via MIDI

Bass Mode

- ◆ In normal mode, pitch is reliably detected down to A0 (55Hz). Turning Bass Mode on lowers the lowest detectable frequency by about one octave to 25Hz (the lowest E string on a bass guitar is approx 41Hz).

Expression and Emotion

Great performance is a lot more than just hitting the right notes. Depending on the style of music, expressive gestures like scoops, bends, vibrato and more can all contribute to the emotional effect.

- ◆ The speed control ensures that the rate of pitch correction (i.e., the speed at which the input pitch is slewed to the target pitch) can be matched to virtually any style of performance.

Program Mode

- ◆ Call up one of 50 individual Programs to control the correction algorithm
- ◆ Each Program consists of a Scale, a Speed setting and Vibrato settings.
- ◆ Programs can be accessed remotely via a foot switch or via MIDI
- ◆ Use Program Mode when a single scale (or maybe two) is all that's required for a particular correction.
- ◆ If you are working in the studio to correct an already recorded track, you might use Program Mode to deal with the track one section at a time, stoping to change Programs between sections.

Use in Live Situations

- ◆ Song Mode lets you follow the most complex harmonic song structures by programming the appropriate series of scales and then stepping through them in performance with a footswitch or MIDI control.
- ◆ Most performance parameters can be controlled with MIDI continuous controllers. Everything can be controlled via SysEx.
- ◆ 20 different songs are provided each of which can be programmed with a series of up to 15 Song Steps. Each Step can contain a Program (with associated scale) or one of a number of navigation controls
- ◆ Each Song also contains its own Speed and Vibrato settings that override those settings in the individual Programs. In this way, an individual Program's scale can be used in any number of songs, each with different Speed and Vibrato settings.

Front & Rear Panel Controls

- ◆ Easy-to-read 20x2 LCD display
- ◆ Six-Segment LED level meters indicate the input signal level in dBs
- ◆ Pitch Change Meter indicates the amount of pitch correction being applied to change the input pitch to the target pitch in real time.
- ◆ Balanced XLR and 1/4" TRS (bal/unbal) inputs and balanced XLR and unbalanced 1/4" TS outputs
- ◆ MIDI In port
- ◆ 1/4" TS (tip-sleeve) footswitch input

How it Works

Uses proprietary digital signal processing algorithms to continuously detect the pitch of a periodic input signal, compare it to a desired target pitch and, if necessary, instantly (no greater than 4 milliseconds) and seamlessly correct it to that target pitch. And with pristine 20-bit data path, 56-bit internal processing and balanced I/O, the only difference between what goes in and what comes out is the intonation. (Dynamic range is 103dB).

ANTARES

AMM-1

Microphone Modeler

Inside this unassuming but stylish 1U rack is contained the spirit of many of the world's most revered micro-



phones. Based on the award-winning technology that made the Antares Microphone Modeler the most talked-about software plug-in of 2000, the AMM-1 lets almost any reasonable quality microphone sound like any of a wide variety of high-end studio mics. From historical classics to modern exotics to a selection of industry-standard workhorses, simply tell the AMM-1 what microphone you are actually using and what microphone you'd like it to sound like. It's really as simple as that. You can even mix and match the bass and treble characteristics of different microphones or add the warmth of classic tube saturation.

FEATURES

- ◆ Proprietary DSP-based acoustic modeling allows any reasonable quality microphone to sound like any of a wide variety of high-end studio mics. Models reproduce the effects of windscreens, low-cut filters, pattern-dependent frequency response and proximity effects.
- ◆ Over 100 mic models are already built in, including an extensive collection of digital models of historical classics, modern exotics, and industry-standard workhorses. You can also add new models by downloading from the Antares web site
- ◆ Create hybrid mics that combine the bass response of one mic with the treble response of another
- ◆ Add a model of classic tube saturation distortion
- ◆ Use during mixdown to change the mic on an already recorded track
- ◆ Incredibly easy to use — simply select the mic you're using and the mic you want it to sound like.

Using patented Spectral Shaping Tool technology, Antares created digital models of a wide variety of microphones, from historical classics to modern exotics, as well as a selection of industry-standard workhorses. Simply tell the AMM-1 what microphone you are actually using and what microphone you'd like it to sound like. It's as simple as that.

With the AMM-1, you can afford to record each track through a model of the specific mic that will best produce that ideal sound you're looking for. Or use it in live performance to get the sound of mics you'd never consider using on stage. You can even use it during mixdown to effectively change the mic on an already recorded track.

Not only do the models reproduce the sonic characteristics that make each microphone unique, but they also give you control of each mic's specific options. Does the mic have a low cut filter? If so, it's in the model. Wind screen on or off? Close or far placement? Each option results in the same sonic effect that it would have with the actual modeled mic. And for that final touch of perfection, you can even add some tasty tube saturation.

Signal Path

Input – For setting the input level of the audio to be processed

Source Mic – For indicating the mic (and the state of its various parameters) that was actually used to record the audio.

Modeled Mic – For selecting the mic (and the state of its various parameters) whose sound you would like to model.

Tube Saturation – For adding a model of analog tube saturation distortion.

Output – For setting the output level of the processed audio. The use of each of the individual controls is covered below.

Rear Panel

- ◆ Balanced XLR and 1/4" TRS line inputs
- ◆ Balanced XLR and unbalanced 1/4" TS line outputs
- ◆ AES/EBU digital I/O is also provided – the output is always active, regardless of the input source (analog or digital)
- ◆ MIDI In connector lets you control the AMM-1 remotely from a MIDI sequencer
- ◆ A 1/4" TS bypass footswitch input is compatible to two types of footswitches; those that are shorted by default and those that are open by default (the ATR-1a will automatically detect which kind of foot switch you have when the unit is powered up).

ANTARES

AVP-1

The following is the list of most of the mics that are included in the AMM-1 ROM. There are many more in the pipeline which will be added as their modeling is completed.

AKG: C12A; C12VR; C414; C414EB; C414B/ULS (Limited Edition Gold, modified by Audio Upgrades and modified by Jim Williams); C535EB; 460B/CK61-ULS; D1; D112; C1000S; D790; D100S; C3000; C4000B; The Tube; Solid Tube

Alesis: AM61

Audio Engineering Associates: R44C

Audio-Technica: ATM-11; ATM-31; AT853Rx; AT3525; AT4047/SV; AT4033a/SM; AT4050; AT4051; AT4055; AT4060

Audix: D4; OM2; OM3-xb; OM5; OM6; CX111; SCX1

B&K: 4007

Behringer: Ultravoice XM8500

Beyerdynamic: M500; M-500 Limited Edition; MC-834

Brauner: VM1; Valvet

CAD: Equitek E100; Equitek E200; Equitek E350; C400S; VSM1; 95Ni

Coles: 4038

Earthworks: Z30x; TC30K; QTC1

ElectroVoice: PL20; N/D357; N-D868; RE55; RE15; RE16

Groove Tubes: MD-1

Lawson: L47MP

Manley Labs: Reference Gold

Marshall: MXL 2001P; MXL 2003

MicroTech: Gefell UMT800

Neumann: U47; U87; U87 70th Anniversary Gold Edition; M147; M149; KM 84; KM184; TLM 103; TLM193; TLM103

Oktava: MC-012; MK-219; MK-319

RCA: BK5A

Rode: NT1; NT2; NTV

Royer: R-121

Sennheiser: MD421; MD441; E609; E835S

Shure: Beta 52; Beta 57A; Beta 58; Beta 87A; Beta 98D/S; SM7A; SM57; SM58; SM81; SM98A; SM98A; KSM32; VP88

Sony: C37P; C48; C800G; C800G(w)

Soundelux: U95S

Tannoy: Large and Small Vintage Ribbons

Telefunken: U-47



The heart of any great song is a great vocal sound. The Vocal Producer combines world-renowned Auto-Tune Pitch Correction with award-winning Microphone Modeler technologies and state-of-the-art vocal processing modules to give you everything you need to create stunning vocal tracks in any musical style. Live or in the studio, the AVP-1 lets you instantly select from a large library of sounds. From gorgeously mellow to seriously twisted, they've included factory presets for a wide variety of vocal styles as well as an interface that makes it easy to create your own signature sounds. (And given the power and flexibility of the AVP-1's processing modules, Antares even included a selection of presets for instrumental and percussion tracks.)

- ◆ **Auto-Tune Real-time Pitch Correction** - Antares's world-renowned Auto-Tune technology lets you correct the pitch of vocals (or solo instruments), in real time, without distortion or artifacts, while preserving all of the expressive nuance of the original performance.
- ◆ **Antares Microphone Modeling** - The TEC Award-winning Microphone Modeler technology lets you give your vocal tracks the characteristics of a variety of high-end studio mics as well as adjust the proximity effect associated with mic distance.
- ◆ **Analog Tube Modeling** - Gives your vocals the warmth of a classic tube preamp.
- ◆ **Variable Knee Compressor** - A state-of-the-art dynamics processor with threshold, ratio, attack and decay controls as well as a continuously variable knee characteristic.
- ◆ **Downward Expanding Gate** - The AVP's gate, with threshold and ratio controls, works independently of the compressor to eliminate noise and breath sounds.
- ◆ **Variable Frequency De-Esser** - The AVP's de-esser tames vocal sibilance with threshold, ratio, attack and decay controls as well as a variable highpass frequency to match any vocal performance.
- ◆ **Flexible Parametric EQ** - You can fine-tune your vocal sound with two independent bands of equalization that let you select from 6dB or 12 dB high or low cut, high or low shelving with variable slope, bandpass, notch and fully parametric peaking.
- ◆ **Automatic Mono or Stereo Double Tracking** - You can automatically mix a doubled track into the AVP's main output or route it to a separate output for post-processing and mixing.
- ◆ **Fully Programmable** - Once you've created the perfect vocal sound for a particular track, every parameter can be saved as a preset for instant recall.
- ◆ **Factory Presets for a Wide Variety of Vocal Styles** - The AVP comes out-of-the-box with an extensive collection of factory presets for a variety of vocal styles. (There is even an included selection of presets for instrumental and percussion tracks.)
- ◆ **MIDI Automation** - Every variable module parameter can be controlled via MIDI continuous controllers for realtime automation.
- ◆ **Really Easy To Use** - No scrolling through endless menus to find the parameter you want. Virtually every major function is only a single button press away.

APHEX

204

PROCESSORS

210

Aural Exciter and Optical Big Bottom

Incorporating Aphex's patented Aural Exciter and Optical Big Bottom,



the 204 enhances detail, clarity and imaging, and adds low-end punch with deeper, more powerful bass to dramatically enhance live, recorded, broadcast and webcast sound.

By extending the harmonics of the audio path, the 204 is able to restore the natural brightness, clarity, and presence that is often lost during analog/digital conversions, processing, or playback through 'less-than-perfect' audio equipment, bringing sound back to life. This makes the 204 ideal for sound recording and mixing, radio and TV, streaming audio, live sound reinforcement, home theater, nightclubs, discos, theme parks and other fixed installations. The Big Bottom with adjustable tune control provides deeper, more powerful bass performance without adding more power amps or loudspeakers and with little or no increase in peak output. There might be many other "enhancers" on the market, but none can match the effectiveness and musicality of the patented processes in the 204— regardless of price.

- ◆ Aural Exciter is scientifically proven to increase intelligibility. It pulls a vocal or an instrument up out of a mix. It punches up an entire mix, even in a noisy or reverberant environment.
- ◆ Two independent, low noise channels
- ◆ Adjustable Tune, Harmonics and Mix Controls. Tunable harmonics enhances the detail and presence of any instrument, voice or even an entire mix.
- ◆ Adjustable Drive, Tune and Mix Controls on Big Bottom
- ◆ Switchable -10dBV/+4dBu operating level
- ◆ Balanced XLR and 1/4" input/output

207 2-Channel Tube Mic/Instrument PreAmp with MicLim



The 207 is an audiophile quality tube mic preamp without the high

cost. In fact, it exceeds the performance of preamps costing many times more. The 207 will reveal the subtlety and power of vintage condensers, ribbons, electrets and popular dynamic mics. Even the world's most respected microphones will sound better. The instrument inputs are also quieter and have more gain than conventional instrument preamps. The MicLim circuitry, previously only available in the flagship 1100 and 1788 mic preamps, makes the 207 virtually crashproof -making it a perfect front end for digital recorders. By combining the best traits of tube and solid state circuitry, the 207 captures a sound that is warmer, fuller and more true to life—whether you are recording, mixing live, broadcasting or webcasting.

MicLim vs. No MicLim

The MicLim is custom designed optical attenuator, located directly on the mic input line that smoothly limits the microphone's output signal according to the MicLim peak detector's control current. Since attenuation comes prior to preamplification, the patented MicLim can increase the Model 207's effective headroom by up to 20dB.

MicLim detects the preamp's output signal and instructs the input attenuator to proportionately reduce the microphone's output level just enough to prevent clipping. MicLim has no effect at all when the preamp's output level is not approaching clipping.

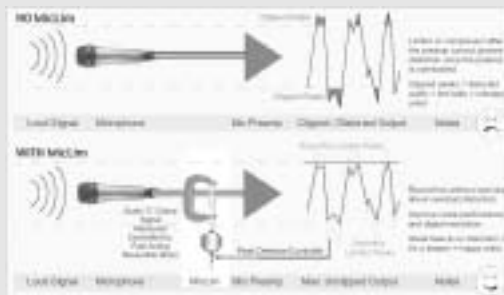

EQUIPMENT LEASING AVAILABLE

320A COMPELLOR

Dual Channel Compressor/Leveler/Limiter

The 320A delivers intelligent compressor action, leveling and peak



limiting simultaneously. This intelligent, versatile and highly affordable processor can be used to solve audio level problems and improve audio signals in the broadcast studio, recording studio, tape duplication house, film dubbing studio and in live sound applications. Patented control circuits include analog computers that continuously analyze the input signal and vary the control characteristics to provide for virtually undetectable operation, regardless of the dynamics of the program. Extremely easy to use, you only need to set the Drive level to generate the desired amount of processing, set the Process Balance control between leveling and compression and adjust the output level for unity gain. The 320A is then ready to provide complete dynamic control - smooth, inaudible compression, increased system gain, desired program density and the freedom from constant "gain riding" - fully automatically! Its unique circuit design actually enhances transient qualities, thus making even heavy processing undetectable.

FEATURES

- ◆ Dual mono or stereo operation.
 - Mono mode offers two completely independent channels of processing to accommodate independent monaural signal feeds.
 - In stereo mode, you can link only the leveling control signals or you can link both the compression and leveling signals.
- ◆ "Invisible" compression characteristics assure tighter dynamics and virtually transparent performance
- ◆ Intuitive front panel metering system displays input/output or gain reduction levels.
- ◆ Intelligent Automated Gain Control (AGC) for consistent program levels
- ◆ All potentiometers are detented for accurate resetting of controls.
- ◆ Operating reference levels are selectable from -10dBV, +4dBu or +8dBu.
- ◆ Leveling Speed (fast/slow) switch is located on the front panel, as is the defeat switch for the peak limiter.
- ◆ An RJ-11 connector on the rear panel facilitates remote relay bypass of the unit.
- ◆ Instantaneous peak limiting for effective system protection (user defeatable)
- ◆ Adaptive control circuits make for fast, simple set-up and no readjustment for varying program dynamics

Frequency Discriminate Leveler (FDL) Circuit

Lab tests and exhaustive research led to the discovery that, under conditions of program leveling, the human ear perceives the onset of low frequency (bass & percussion) transients differently from transients at higher frequencies. This perception, as it turns out, is a direct function of the relative attack time of the leveler. Without FDL, there is a much greater chance that low frequency transients can create an audible "bass pull back" effect. In addition to a potential loss of bass and/or low end "punch", mid and high frequency processing can be negatively impacted. To the listener, the effect can be heard as a perceived loss of bass or even "pumping" at the mid and treble frequency ranges.

FDL eliminates this problem by allowing low frequency transients to trigger a slower attack time on the initial transient. High frequency leveling is still controlled within the attack time determined by the onboard computer. For the listener the benefits are:

- > No more bass pullback effect
- > More bass punch for better music mixes
- > Fast leveling can be used in more applications
- > Reduced audio distortion in the leveling mode

Dynamic level control is easy to attain. Just sit in front of your mixer, with your fingers on all the faders for all of your tracks. Then, when the signal on each track gets louder, immediately pull down that fader. When the music gets softer, instantaneously turn it up. Like we said, easy! Especially if you only have a 24 or 32 channel mix going...

Okay, maybe NOT so easy - unless you own an Aphelex Compellor! Not a compressor or limiter, the Compellor is an incredibly intelligent leveler. It automatically gives you dynamic control over your mix, letting you maintain optimum average levels at all times. Your recordings will sound louder, fatter, fuller and punchier - without sounding squished, squashed, flat or lifeless (the usual compressor artifacts) because the transients still get through, and your mix still has room to breathe.

If you want a more polished, mastered, and overall louder "pro" sound for your recordings, the Compellor is the best answer!

APHEX

622

Logic Assisted Expander/Gate



The choice of professionals in recording, broadcast and sound reinforcement, the 622 incorporates proprietary detection circuitry to provide the most reliable, accurate and stable operation of any gate. And with the ability to increase your dynamics along with lowering the noise floor of your gear, comes the highest quality VCA's to assure that you will never hear a click in your material again! The 622 also offers the highest quality audio path, flexible high "Q" key filters, key headphone outputs on the front panel and remote controlled bypass relays. Whether using it to keep your vocals clean and your bass sounds tight and fat or to control feedback, the 622 is a phenomenal addition to your processing rack!

- ◆ Logic Assisted Gate Circuitry combines sophisticated level detection with logic generated control voltage assuring positive, stable and accurate triggering regardless of attack time
- ◆ VCA 1001 voltage controlled attenuator assures the highest audio quality, speed and freedom from DC control feed through (no clicks regardless of attack time)
- ◆ Switchable parametric key input filters (-24 dB/octave filters with frequency and bandwidth controls)
- ◆ Lowest distortion (0.005% typical) and widest frequency response (5Hz-100kHz)
- ◆ Front headphone jack to monitor key input without disrupting audio output
- ◆ Dedicated downward expander mode allows high resolution of ratio adjustment from 1.2:1 to 10:1.
- ◆ Switchable ducking mode with fully adjustable control of trigger threshold, attack time, hold time, release time, expander ratio, and attenuation range
- ◆ 119 dB dynamic range—suitable for digital and analog recording applications
- ◆ Can be used in all recording and live performance applications
- ◆ Simple and accurate metering system
- ◆ Servo-balanced input and output circuits
- ◆ +4/-10 operation, rear panel selectable
- ◆ Hardwire relay bypass: remote controllable
- ◆ 5-year limited warranty

661

Tube Compressor/Limiter Expressor / Easyrider with Tubessence



This single channel compressor/limiter incorporates three patented Aphex circuits in one rack space: Tubessence, Easyrider and High Frequency Expander. Use the 661 to control dynamics for mixdowns, protect your sound system's loudspeakers from transients and distortion or shape the sound of individual instruments and vocals. Compress dynamic levels without fear of reducing frequency response. What ever type of dynamics control you're looking for, it can be done with the 661.

- ◆ Easyrider is an Auto mode that takes the guess work out of compressing individual instruments and vocals especially in live mixes. WDC (Wave Dependent Compressor) circuit automatically adjusts attack and release times according to the complexity of the program material. It's No-Knee compression curve makes the transition into compression virtually invisible.
- ◆ Tubessence provides that "vintage" tube sound without high heat, bulk, short life, fragility and sonic variability.
- ◆ In the manual mode, the 661 provides the full compliment of compressor adjustments, such as ratio, attack and release, for maximum flexibility. Express yourself and get those "punch", "slap", "fat", "pump", and "squeeze" sounds fast and clean.
- ◆ High Frequency Expander (HFX) decompresses high frequencies, with user-adjustable ratio and corner frequency. Add "life" and "air" to your compressed signals without fear of background noise pumping.
- ◆ Spectral Phase Refractor (SPR) restores clarity and punch to tracks. Bass frequencies are more defined with more apparent power. Higher frequencies gain detail and presence.

Two-Channel Auto Compressor



The 108 is a two channel auto compressor with Easyrider technology for the best sounding, most transparent compression available. Easyrider thinks for you, continuously monitoring the complexity of the program material and instantly adjusting the compression ratio and time constants accordingly—just set and leave it alone! Think of it as having an extra set of hands while you play. Easy to use, simple to set up, the 108 sounds completely transparent on individual voices, instruments and submixes as well as full program material.

- ◆ Rotary speed control varies the range of the WDC release time
- ◆ Dial in the desired amount of compression, up to 20dB available
- ◆ Gain reduction meter with 10 LED steps
- ◆ Channels linkable for stereo operation
- ◆ Switchable -10dBV / +4dBu operation
- ◆ In addition to the world-class ApheX 1001 Class A VCA, ApheX's Easyrider Technology is a combination of two circuits:
 - Wave Dependent Compressor (WDC), a patented circuit which automatically adjusts compressor time constants according to program complexity:
 - No-Knee compression curve circuitry which automatically adjusts the compression ratio. One of the most annoying aspects of conventional compressors is the audible “pumping” or “breathing” side effects heard when the signal exceeds the threshold and the compression “kicks-in”. No-Knee ensures there is no abrupt transition to a high compression ratio.

109

Two-Channel Tubessence Parametric Equalizer



In a class by itself, the 109 has the flexibility to switch between Mono 4-band (1x4) operation when you need to address complex equalization issues or Dual 2-band (2x2) operation when more general equalization is required. For even more control, a switch is provided for selection of either peak/dip or shelving on all four bands. Each band provides variable boost/cut (± 15 dB), variable frequency (20Hz – 2kHz or 200Hz – 20kHz) and variable bandwidth (1/5 octave to 2 octaves) control. The 109 can be used for a combination of applications including gentle frequency response shaping and notching of specific frequencies, like 60Hz hum.

The 109 also includes the patented Tubessence circuit which provides true vacuum tube circuitry and sound without transformers, high heat, short life, fragility, and sonic variability. Due to the added “sweetness” of Tubessence, you will never hear an equalizer sound like the 109. Operating the unit in the EQ flat mode allows the signal to pass through the Tubessence vacuum tube stage without any gain change, providing you with a great Tube Processor. This feature proves helpful for digital users who wish to “warm-up” their digital signals.

APHEX

720/722 DOMINATOR II

Precision MultiBand Peak Limiters

PROCESSORS

214



The Dominator II is a stereo MultiBand peak limiter designed to fit a wide range of applications. Through the use of MultiBand techniques along with proprietary circuits, the audibility of limiting action has been greatly reduced, especially when compared to conventional limiters. This means that greater limiting depth is possible, resulting in higher loudness with maintained audio quality. At virtually any limiting depth, the Dominator II is free of "hole punching", "dullness", and most other effects normally associated with limiters. As a peak overshoot protection limiter, the Dominator II is undetectable in line while it absolutely prevents peak levels from exceeding a user settable output level. In addition, the desired limiting effects of greater audio density and increased punch are readily available with the Dominator II.

Why is The Dominator So Special?

A significant problem with wideband processing is "spectral gain inter-modulation" which occurs when one part of the spectrum controls the level of another part. A typical situation is a vocalist being "sucked down" every time the kick drum hits. Since most energy is contained in the lower frequencies, they tend to control the level of the entire spectrum. When the lower frequencies are above the limit threshold the higher frequencies are attenuated thus causing the output to be dull.

Multiband processing solves this by splitting the audio into two or more frequency bands and processing each band separately. However, more bands can result in more parameters to control including a method of summing the bands together again. While giving you flexibility, it also requires different settings for almost every different source. The 720 and 722 use program dependent, intelligent circuits to reduce the number of controls. You therefore have flexibility to shape the sound while quickly and easily achieving the goal of consistent, effective limiting.

The Secret Ingredient: ALT

A multiband processor splits the audio into separate bands, individually limits each band, and then sums the bands together again. Even though each band's peak output is predictable, summing the bands together produces an unpredictable peak output.

Using a wideband limiter after summing introduces the drawbacks of wideband limiting. Using a clipper on the summed output can cause too much clipping distortion if the summed output is too high. To avoid this, the limiters' thresholds are set far below the clipper threshold resulting in a loss of loudness, and a great amount of processing.

The Dominator II produces a predictable peak output while maintaining maximum loudness without audible distortion using the Automatic Limit Threshold (ALT).

The outputs of the three bands are summed and sent to the ALT detector circuit. If the sum exceeds a reference value, the ALT reduces the thresholds of the individual limiters. When the summed output falls below the value the limit thresholds return to their original setting.

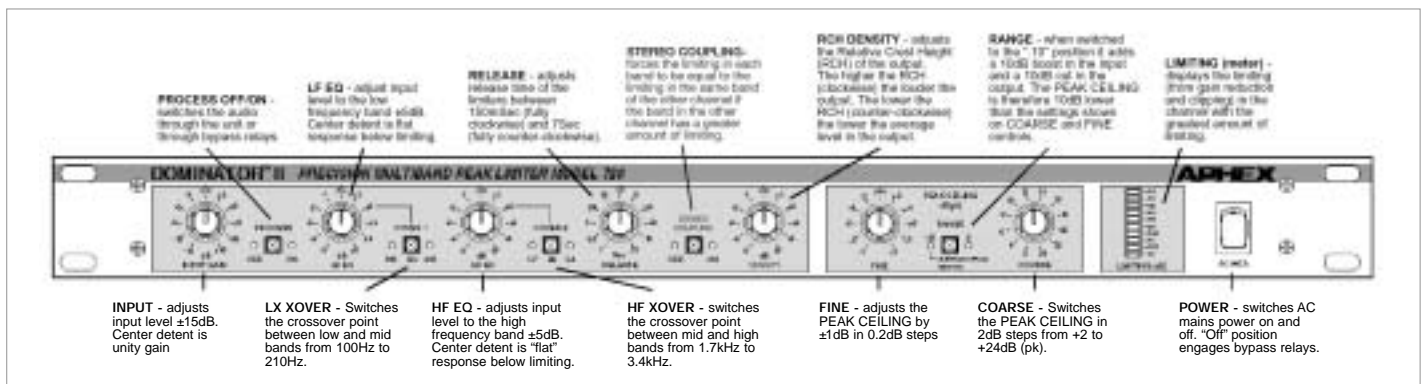

EQUIPMENT LEASING AVAILABLE

720/722 DOMINATOR II

They Both Feature

- ◆ Peak Ceiling Trimmable in 0.2dB steps over a 34dB range
- ◆ 3-bands of limiting with switchable crossover frequencies
- ◆ Patented Automatic Limit Threshold (ALT) circuitry
- ◆ Freedom from pumping
- ◆ Freedom from Spectral Gain Intermodulation
- ◆ Adjustable density (relative crest height)
- ◆ Calibrated detented potentiometers
- ◆ 104dB dynamic range
- ◆ LF and HF EQ provides shaping equalization below peak ceiling
- ◆ Relay bypass is remote controllable
- ◆ Servo-balanced transformerless inputs and outputs

722

'Broadcast Dominator' Step-up Features

- ◆ Pre-emphasis is an equalization curve expressed as a time value based on the ratio of a resistor and capacitor. The higher the value, the greater the equalization. It has been employed as a noise reduction technique for broadcast and transmission links. There are primarily two world standards- 50 and 75 microseconds.
- ◆ The 722 Dominator II, has separately switchable pre and de-emphasis curves. When pre-emphasis is switched in, either 50 or 75 microseconds, the equalization curve is added after the input stage and before the limiters. When de-emphasis is switched in, the complementary de-emphasis curve is inserted after the final clipper and before the output stage.
- ◆ When both pre and de-emphasis are switched in, the frequency response of the output is flat. When the input is below threshold and as the input increases above threshold the output takes the shape of the de-emphasis curve.
- ◆ When both pre and de-emphasis are switched out, the 722 works exactly like the 720.

120 - 1 x 4 Servo-Balanced Distribution Amp

If you are in the market for a high-quality, performance driven Distribution Amp, then the Aphex 120 is just what you are looking for! With specifications better than digital recordings (better than 90db and 5Hz - 100kHz specs), the 120 is



designed from the ground up to be rock-solid in any situation. So, for any situation that you can throw at it, Aphex's 120 Distribution Amp offers 4 outputs that perform exceptionally well!

The Model 120 is a high performance audio distribution amplifier with a single high impedance input and four low impedance outputs, all electronically servo-balanced. The 120's transformerless circuits are designed for wide, flat frequency response free from ringing or overshoot, making it ideal for distribution of SMPTE time code as well as audio. Each output has its own amplifier and level control for maximum versatility and isolation. The sturdy steel chassis may be used stand-alone or rackmounted, singly or in pairs.

Maximum gain without distortion. Whether working in analog or digital, it's what we all strive for. The easiest and best sounding way to get it? The incredible Dominator II multi-band limiter.

Aphex's goal with the Dominator was first and foremost incredible SOUND QUALITY. Other manufacturers fool around with their digital this and that, look ahead schemes, and other voodoo tricks to attempt to attain what Aphex has been providing all along - effective level control— with undeniably transparent, punchy audio quality.

Not settling for just stopping peaks, the Dominator uses controlled, instantaneous musical clipping to control peaks, while still letting you increase the average level of your mix. This adds punch and power, but establishes a multi-band brickwall limit. In short, the Dominator lets you push your levels to their absolute maximum, with NO DISTORTION or negative artifacts. Your mix is simply as loud as it can be, with no worries about overload!

The Dominator is also ideal for establishing optimum input levels to your digital gear with no chance of peaks overshooting or causing harsh digital clipping. Putting one in front of your digital recorder is the best thing you can do for your recordings! And, are you using "in-ear" monitors on stage? The Dominator is the only limiter to consider for protecting your hearing, nothing else comes close - just ask virtually ever touring pro out there.

124 - Bi-directional Audio Level Matching Interface



So it's time to mix and match your studio gear's inputs and outputs... but everything is starting to sound awful?!!

A CD player there, an ADAT recorder there... Throw in a few keyboards and a mixer. Throw in trying to match levels with Pro Tools and you've just created yourself a nightmare! Why? Simple... Start mixing different line levels (-10dBV for your keyboards and +4 for your ADAT or Mixer) and you're mixing levels are going to be all over the place. One line is going to be really hot while another is barely audible. But don't forget the noise or loss of dynamics that you are going to have with your gear when you start trying to match levels! That's where the Aphex 124a comes into the picture! The Aphex Audio Level Interface is designed to allow use of -10dBV consumer hi-fi equipment with +4 or +8dBm professional and industrial audio systems. It provides an extremely clean, reliable two-way buffer so both systems can operate at maximum performance levels, matching impedances and operating levels. We are not exaggerating when we tell you that the Aphex 124 is going to make your recording life so much easier!

APHEX

1100

2-Channel Tube Mic Preamp with 24-Bit 96KHz A/D Converter

PROCESSORS

216



With the 1100 your microphones come alive with unprecedented focus, clarity, space and detail. Recorded voices demand attention because they are uncannily present, powerful, and appealing. Most tracks will need much less technical fixup to stand on their own. Offering the lowest noise possible, 24-bit 96kHz digital outputs and Aphex's exclusive MicLim protection circuit, the dual channel 1100 is designed for digital or analog recording, broadcast and production. The breadth of features, superlative specifications and warm sound of tube processing make it the mic preamp of choice for state of the art audio production. Breakthrough technology allows the 1100 to deliver an EIN of -135dB. The MicLim circuit adds an additional 20dB of head-room, making it virtually impossible to overload the preamp. Since the A/D converter is scaled to clip at the same point as the mic preamp, the digital conversion will be at the highest possible resolution without overload. Aphex's patented tube circuitry provides the open, present, real and warm sound.

Each channel has a tunable low cut filter (30-195 Hz), tunable gain from 21 to 65 dB and multi-turn output trim. Both channels have individual switches for 20dB pad, polarity, test tone, phantom power on/off, mute, MicLim, Clock Source (Internal at 44.1, 48 or 96kHz and External). The back panel includes (for each channel) includes XLR In/Out, 1/4" balanced out, AES/EBU out (XLR), Word Clock In/Out (BNC), remote mute control jack.

MicLim Commands Enormous Headroom

Wide dynamic range means more than low noise. It also means generous headroom to handle extremely loud sounds. Normal mic preamps can't be protected from clipping, because any compression or limiting device comes after the fact. Unexpected loud sounds will jam the preamp into clipping, forcing you to ride gain or suffer distortion. Aphex's exclusive MicLim peak limiter works on the mic's own output signal, before any amplification takes place. It automatically and transparently limits the peaks before they can get clipped! MicLim is based upon custom engineered opto-coupler technology so it is sonically pleasing while in action. Typically 16dB of useful limiting is available, effectively adding that much more to the already huge dynamic range of the 1100.

Class A Circuitry

All discrete Class A PNP first stage and the patented Reflected Plate Amplifier (RPA) tube circuitry in the second stage and in the output stage. These circuits provide the 1100 with unique sonic characteristics while maintaining low noise and high common mode rejection.

What's Thermionics?

The art and practice of using and developing electron tubes (which are also known as "valves" or "vacuum tubes") is frequently referred to as "Thermionics" in scientific and engineering literature. Inside of electron tubes, thermionic emission is obtained by heating the cathode to incandescence by the use of a filament. This causes electrons to escape from the cathode's surface. The cathodic emission is ultimately gathered by the tube's plate circuit and converted into an output signal. The plate current is controlled by a comparatively smaller input signal applied to an intervening electrode grid, yielding signal amplification. Any device utilizing this tube circuit technique may therefore be called a "Thermionic Amplifier".

Superior Dynamic Range

Besides the rich, involving sonics of the 1100, imagine what its incomparable dynamic range can bring? -135dBu EIN (Equivalent Input Noise) commands awesome quietude. Most professional mic preamps have an EIN of -124dB or so. Some may even reach as low as -127dBu under optimum conditions. With an unprecedented low of -135dBu at 65dB of gain — the only source of noise will be the mic itself. The increase of the perception of size and depth during recording can be awesome.

LoCaF Low Cut Filter

LoCaF (Low Cancellation Filter) allows up to 20dB of low frequency cut without using any headroom or triggering MicLim. This sweepable second order low cut process is realized through a servo cancellation method that is nodally meshed at the intersection of the first and second stages. Tunable in 11 steps from 30 to 195 Hz, LoCaF gives you complete freedom from rumble and wind blast overload, even in extreme conditions.



www.bhphotovideo.com

The 96KHz/24-Bit A/D Converter

The 1100 incorporates a full spec A-D converter to offer full-featured AES/EBU digital audio output. Clock synchronization options allow locking to standard "word clock" and to AES/EBU clock received via back panel BNC input. The internal clock may be set at 44.1, 48 or 96kHz sample rates. When set for external clock reference, the BNC input jack directly links to the BNC output for easy daisy-chaining of multiple 1100s. All digital audio settings are controlled and displayed on the front panel.

700 Hz Tone

How often have you wished you could get a calibrated tone from your mic preamp to set the console match gain or the record level? The 1100 provides a selectable test tone at exactly 20dB below the digital and analog clipping points. This tone transfers to both the analog line output and the digital audio output whenever activated.

Line Output Calibrate & Level Normalization

With the 1100 you don't have to compromise noise or headroom to get a level match to your system input. Using the test tone, simply use the Line Output Calibrate precision adjustment on the front panel in conjunction with the back panel +4dBu/-10dBV Normal Level switch to get a perfect signal level on your recorder or mixer meters. You'll be guaranteed 20dB of headroom and the lowest possible noise.

Soft Switch Mute

Wouldn't be nice to have a convenient way to soft mute the microphone? The 1100 includes a clickless, thumpless, mute feature that can be operated from the front panel or from a remotely located switch. A back panel phone jack allows you to attach any kind of switch to mute the channel from any desired location.

Slow Ramping Phantom

Thumps are greatly reduced by the slow changing 48-volt phantom power source of the 1100. Not only does this protect your ears and monitors, but it protects delicate microphones from the shock of a sudden power inrush. You will normally hear the mic fade in quietly rather than loud thumps and flutters when phantom is turned on.

1788—REMOTE CONTROLLED 8-CHANNEL PREAMP

The 1788 is an 8-channel remote controlled mic preamp designed for production, broadcast, theater, recording and live sound. For live sound, not only does the 1788 place high quality preamps on stage near the microphones, but it allows a



1788 shown with the 1788R Remote Control

preamplified signal to be split for monitors, recording, and other feeds without a loss of quality due to loading of the microphone. The result is simply higher quality audio wherever the signal is needed. When used with the optional 1788R Remote Controller, up to sixteen 1788s (128 channels) can be remotely operated at the mix position with the actual 1788s located as close as possible to the microphones. The benefits are:

- ◆ The ability to run long cables without degrading the signal or audio quality
- ◆ The 1788's MicLim limiter circuit allows the signal to run at as high a level as possible without the fear of clipping at the consoles, amplifiers, signal processing or analog and digital recorders.
- ◆ Multiple splits can be made from any input without loading the microphone or causing any audio degradation.
- ◆ The 1788 can be controlled by either MIDI, RS-232 or RS-422. The control protocol is MIDI so that anything producing MIDI can act as the controller, such as a light controller board, a show control system, a sequencer, a DAW, a MIDI controller, a keyboard or a computer using 1788 control software.
- ◆ The 1788 has an RS-422 output which can be used to daisy chain units. Of course, all mic preamp functions can be controlled on the units as well. Up to 16 units (128 channels) can be controlled by one control line.
- ◆ The control software has a screen which displays all parameters and metering of one unit at a time and up to 16 units may be called up. All channel status information and metering are displayed in real time. A channel can be selected and settings modified. Scenes can be saved, modified and recalled in the control software.
- ◆ When using the optional 1788-1 digital module, digital audio can be simultaneously routed using three digital formats, AES/EBU, ADAT optical, and TDIF.
- ◆ Using the 1788R Remote Control minimizes the amount of hardware at the mix position
- ◆ Since there is no splitter, there is no need for cumbersome power supplies for condenser mics - the 1788 also provides phantom power
- ◆ You will no longer have the expense of buying and transporting heavy splitter boxes

TUBE MIC PREAMPS

Tube MP Series

ART's Tube MP series is a range of compact, professional tube preamps that provide sound quality and features that far surpass the "on-board" preamps found in today's low-cost mixers and multi-track recorders. Their TEC award nominated hybrid design utilizes the latest solid state and tube technology, based around a hand-selected 12AX7a tube, allowing them to add warmth and fatness to a signal while maintaining exceptionally low-noise and high quality. And though their primary application is microphone pre-amplification, they are also exceptional direct boxes, capable of impedance matching, amplifying and improving the sound of any instrument plugged into it—making them a must-have in any audio toolkit. Whether you're working with four-tracks or twenty four, tape or disk, analog or digital, a Tube MP will yield professional results at a fraction of the cost of comparable equipment.

**TUBE MP**

There's no better way to get that smooth, warm sound than with the world's #1 mic pre, the Tube MP. The one that started it all, the Tube MP provides superior preamplification for microphones, instruments and line level sources, and uses a 12AX7A tube for over 60dB of gain to warm even the most frigid signal.

Pre Amp

- ◆ Variable input and output gain controls
- ◆ +20dB Gain/Norm Switch
- ◆ Switchable +48V phantom power
- ◆ Phase Reverse/Norm Switch –reverses the polarity of the output signal
- ◆ Power/Peak LED – Green when power is on, red if 6dB below hard clipping

Superior Circuitry

- ◆ Transformerless design throughout ensures exceptional signal integrity and extremely low noise
- ◆ XLR mic input utilizes a hybrid multiple paired transistor/opamp design providing extremely low noise and excellent CMRR

Inputs/Outputs

- ◆ Active balanced XLR mic input and high impedance 1/4" instrument input made it excellent as a tube DI for guitar, bass or keyboard as well
- ◆ Active balanced XLR and unbalanced 1/4" outputs

TUBE MP OPL

The Tube MP OPL offers all the features and functionality as the Tube MP plus it adds ART's "OPL" Output Protection Limiter, which precisely and accurately, controls and maintains the output peak signal. The OPL circuitry is crucial in protecting the next link in a signal chain - such as a hard-disk recording system or a sound card.

TUBE MP Studio

The Tube MP Studio steps up from the Tube MP OPL with the inclusion of an output level VU meter, enabling you to keep the signal consistent with desired levels.

The meter also reflects the impact of the OPL circuitry on the signal. For example, if the signal is "in the red" on the meter, the meter will reflect the attenuation of the signal when the OPL is activated, and the signal is brought out of the "red".

**TUBE MP Studio V3**

Tube MP Studio V3 takes things to a new level with Art's exclusive V3 (Variable Valve Voicing) technology. Using presets created and fine-tuned by some of the industry's top studio and live-sound engineers, V3 provides optimized reference points to begin the recording process. V3 allows you to select between a multitude of preamp settings designed for guitars (electric and acoustic), keyboards, bass guitars, drums, vocals and more. V3 gives you incredible presets for every instrument you record, so all your recordings will sound professional. You can also tweak the presets to hone your perfect tone.

TUBE MIC PREAMPS

TPS/DPS

2-Channel Tube Mic Preamp Systems

The **Tube Preamp System (TPS)** is basically a two-channel, rack mountable version of the Tube MP Studio V3. Like its single-channel counterpart, the Tube Preamp System (TPS) features twin high performance discrete preamplifiers coupled with ART's

proprietary Variable Valve Voicing (V3) 12AX7A gain stage. OPL (Output Protection Limiter) is available to control overshoots and normalize levels before overloading or digital clipping occurs to the next link of the signal path. It can accept +20dB peaks while maintaining over 120dB dynamic range and incredibly low distortion. And unique to its class, the TPS provides level monitoring via two analog meters. High-Z instruments or balanced microphone signals are input through front and rear panel jacks.

The **DI/O Preamp System (DPS)** has all the features of the TPS plus adds digital outputs. A versatile insert loop on each channel provides access for additional signal processing or direct access to ART's high quality A/D converter. Separate gain controls on analog and digital outputs allow you to optimize the unit for simultaneous applications. Digital outputs include S/PDIF, TOSLINK or ADAT (front panel selectable). The A/D is front panel adjustable from 44.1 to 96kHz or syncs to ADAT or external word clock (32kHz to 100kHz).

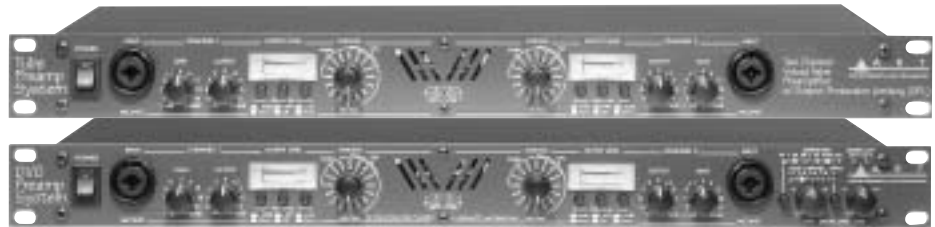

PRO MPA/DIGITAL MPA

Professional Two-Channel Tube Mic Preamps

Multi-purpose tools for audio engineering and recording, the PRO and Digital MPAs are ART's top-of-the-line mic preamp. Developed with studio and live sound engineers using the best components available, they deliver "the sound" while ensuring a lifetime of quiet, reliable performance. Backed by five-year warranty.

They both feature:

- ◆ Variable input impedance for flexible mic voicing (150 to 3000 ohms)
- ◆ Selectable tube plate voltage
- ◆ Large VU meters and Peak-Hold LED meters
- ◆ Metering is switchable between output level and tube warmth
- ◆ 1/4" input has a high impedance which makes the PRO MPA perfect for DI or line level applications.
- ◆ Each channel features independent input and output level controls and a variable high pass filter.

Digital MPA Step-up features:

- ◆ A/D insert jacks, 44.1/48/88.2/96/176.4/192 kHz internal sample rates
- ◆ Rotary encoder for quick selection sample rate and output format
- ◆ Separate analog and digital level controls; fast and accurate digital level LED meters
- ◆ ADAT optical I/O; sync to incoming ADAT data rate
- ◆ Selectable optical (S/PDIF or ADAT) and AES/EBU output
- ◆ Two word clock jacks allowing loop through
- ◆ Attractively styled with a light gold front panel and matching knobs

PRO VLA

Professional Two-Channel Tube Compressor with Vactrol

The rack-mountable (2RU) PRO VLA (Vactrol-based Leveling Amplifier) is a powerful tool for audio engineering and recording. It features two independent channels of analog leveling/compression designed to work seamlessly with any recording, sound-reinforcement, or electronic instrument setup. ART's PRO VLA circuitry utilizes the latest and most advanced analog and tube technology. Using a transformerless design throughout, the PRO VLA maintains exceptional signal integrity and extremely low noise. Its VCA-less design utilizes optical electronics (Vactrol) coupled with a 12AX7 vacuum tube gain stage for superior musical performance.



The PRO VLA is a soft knee leveling amplifier by design. Although it is capable of providing a thoroughly "squashed" signal, it excels in areas where transparent, expressively musical dynamics control is desired.

In addition to making signal levels more manageable, it is common practice to apply compression or limiting to a signal to make it louder or more "in-your-face". By utilizing opto-electronics, the PRO VLA allows you to add more compression without sounding like you're squashing the daylights out of the signal.

Unlike typical compressors which use VCAs to control level detection, the PRO VLA is very musical. The nature of its operation is much like the way your eye adjusts to light. Just as your eye transparently adjusts to changes in light, the PRO VLA adjusts to changes in signal level.

Developed in partnership with studio and live sound engineers, the PRO VLA possesses a "sound" that is not available from any other compressor — at any price! Designed and constructed with the absolute best components, assuring a lifetime of quiet, reliable performance.

TUBE COMP *Tube Compressor*



The Tube Comp features electro-optical (Vactrol) and tube electronics to deliver superior dynamics control, musicality and classic sound without the pumping, breathing and noise associated with most VCA-based compressors. Very fast attack and release response times provide the classic punchy and transparent characteristics of the "LA-" type levelers; finely tuned auto setting behaves like the classic stereo modules, providing a smooth, loud, and fat sound.

FX-1 *Digital Effects Processor*

Housed in a compact, all-steel chassis are 60 stunning digital signal processing effects. Choose from clean, lush reverbs including halls, chambers, plates, gated, reverse and true stereo rooms and plates. Add powerful delays, thick chorus, shimmering flange, vintage tremolo and panning effects, pitch shifting, precise combination multi-effects and you have the easiest to use, best sounding, compact processor on the market.



TUBE CHANNEL STRIPS

TUBE PAC *Tube Mic Preamp/Optical Compressor*

The TUBE PAC combines the world's most popular tube mic/line preamp (Tube MP) and an optical tube compressor into a single convenient table-top design. Easily placed in the studio or on the stage, the Tube Pac offers immediate access to all the controls, features, and metering. The mic/line preamp stage provides over 70dB of gain, +48v phantom power, phase reversal, and is capable of warming up any instrument or microphone. The tube compressor is a VCA-less, optical design—similar to that of the "classic" tube compressors. Its ultra-musical sound is ideal for voice and instrument applications. Threshold, compression/limiting ratios, adjustable release times, bypass, gain reduction metering, and output gain controls are provided.



- ◆ Hand-selected 12AX7a vacuum tubes – one for the preamp and one for the compressor.
- ◆ Precision detented potentiometers
- ◆ Bypassable compressor circuitry
- ◆ Balanced XLR and unbalanced 1/4" inputs and outputs
- ◆ Input level controls allows you to dial in the desired amount of tube warmth and then independently set the output level from the compressor circuitry.
- ◆ LED level indicators let you monitor the output of the tubes for harmonic content.
- ◆ Switchable +48v DC phantom power
- ◆ The ultimate tube DI box for instruments
- ◆ Fat and warm gain with musical dynamics control
- ◆ Aircraft-quality extruded aluminum chassis

TUBE CHANNEL *Tube Mic Preamp/Optical Compressor/EQ*

A rackmount version of the TUBE PAC, the TUBE CHANNEL also adds a 4-band, tube-based parametric EQ and analog VU meter.



- ◆ Award-winning, tube-based preamp features over 60dB of gain, +48v phantom power, and a 20dB pad.
- ◆ The optical compressor features compression and limiting settings, selectable release times, adjustable threshold, and output level controls. Gain reduction is displayed via a four-segment LED array.
- ◆ The 4-band parametric EQ section provides selectable high and low shelving filters with two mid-bands which sweep from 20Hz to 20kHz. The mid-bands overlap from 200Hz to 2kHz for the ultimate in flexibility.
- ◆ Insert points are available between each of the three processing sections. These inserts provide direct outputs from the preamp and the compressor for signal routing flexibility. Additionally, these inserts allow each processing section to be isolated for independent usage or to change the order of the processing sections (eg. you can place the EQ before the compressor).

PRO CHANNEL

Professional Tube Mic Preamp/Optical Compressor/EQ

Redefining the term "channel strip" the PRO CHANNEL combines three independent world-class modules: tube mic preamp, switchable optical/variable mu compressor, and tube EQ to create the world's best-sounding and most affordable professional recording channel.



In addition to the compressor module, the PRO CHANNEL features a Variable Mu circuit. Users can select between ART's award winning optical/tube compressor or the coveted Variable Mu circuit (a design made popular by the sound of the old broadcast limiters – now costing thousands of dollars). The Variable Mu circuit is fast, fat and a bit aggressive, and has joined the Pro VLA in becoming a legend among compressors. The 4-band parametric equalizer has selectable Q for the two sweepable mid-bands. As with all design elements of the Pro Channel, these Q options were fine-tuned by some of the industry's top studio and live-sound engineers.

- ◆ Three hand-selected vacuum tubes
- ◆ Warm, smooth, and silky sound quality
- ◆ Selectable VU metering (mic pre out, compressor out, or main out)
- ◆ Tube character and gain reduction LED arrays
- ◆ Balanced XLR and unbalanced 1/4" inputs and outputs
- ◆ Precision detented potentiometers
- ◆ Insert points between preamp and compressor, and compressor and EQ
- ◆ Five-Year Warranty

441/451/455

Dual 15-Band/Single and Dual 31-Band Graphic EQs

ART's high performance 441 (Dual Channel 15 band 2/3 octave), 451 (Single Channel 31 band 1/3 octave) and 455 (Dual 31-Band 1/3 octave) graphic EQs feature constant Q circuitry, 20mm oil-damped precision detent sliders with a selectable boost/cut range of ± 6 or ± 12 dB, multiple inputs/outputs, adjustable high pass and low pass filters, 4-segment LED level metering with clip

level indicators, variable input level controls, internal power supply with selectable line voltage, and ground lift switch. They also offer automatic relay bypass of audio, an essential function if power is lost. They are ideal for any audio application where precision frequency tailoring, reliable performance, rugged design and extremely silent processing is of the utmost priority.

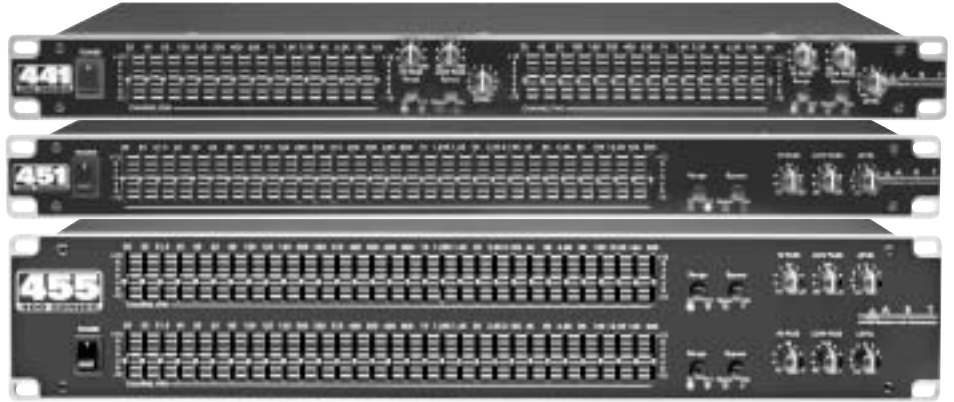

- ◆ The high pass filter rolls off lower frequencies to decrease rumble or low frequency hum from a signal. Its range is adjustable from 10Hz to 250Hz. Frequencies below this setting are rolled off, while frequencies above are unaffected.
- ◆ The low pass filter rolls off higher frequencies to reduce hiss or sibilance from a signal. Its range is adjustable from 3kHz to 40kHz.
- ◆ Multiple input and output configurations are provided for ease of use and incorporate paralleled connections. The XLR and 1/4" TRS connectors use active-balanced, low-noise circuitry and both connectors may be used in an unbalanced configuration. The RCA jacks are unbalanced. The input level control covers a wide range and easily accommodates -10 and +4dB signal levels.
- ◆ Each channel has its own bypass switch with LED indicator.
- ◆ The 441, 451 (1RU high) and 455 (2RU) are housed in a rugged, all-steel chassis
- ◆ They are ideal for any audio application requiring precise equalization. Use them in live sound systems/PA, permanent or fixed installations, church, DJ, home and project recording, and monitor systems.

ART's EQs are used in a variety of applications such as live sound, recording studios, instrument racks as well as any conventional fixed installation environment. Use them wherever precise modification of the frequency contour of a sound is needed. The graphic EQ is a powerful tool for solving a number of audio problems and creating interesting sound textures.

Patch the EQ between your mixing console and power amps to allow you to alter the overall mix to better match your environment. Use them between your monitor mixer and monitor power amps to aid in the removal of feedback inducing frequencies. Patch into a channel insert to EQ one channel or track individually. Run your instrument directly into the EQ to enhance its sound before reaching a power amplifier or instrument amplifier. Patch them into the effects loop of an instrument amplifier or between a preamp and power amp to have precise control over the complete sound.

442/452

Long Throw, Dual 15-Band and Single 31-Band Graphic EQs

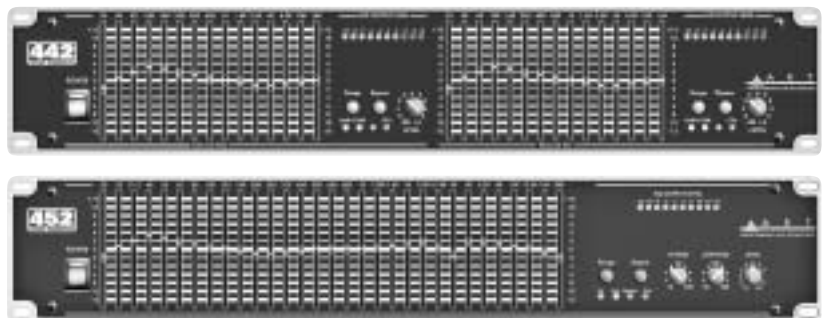

Same as the 441 and 451, the 442 and 452 step-up with 60mm long throw sliders & 10-segment LED meters for output

HQ-15/HQ-31/HQ-231

Dual 15-Band/Single and Dual 31-Band Graphic EQs with Feedback Detection

Stepping up from the 442 and 452, the HQ-15 (Dual Channel 15-Band EQ), HQ-31 (Single-Channel 31-Band EQ) and HQ-231 (Dual-Channel 31-Band) are equipped with ART's proprietary FDC (Feedback Detection Circuitry) to help you keep live sound under control. Different from other systems in that it is extremely fast and accurate, FDC utilizes a set of led indicators that show which of the many EQ bands has the greatest energy. And while FDC illuminates the band with the greatest energy with the brightest LED, it doesn't fully discriminate between bands and will not get "stuck" on one band when there is no signal.

The LED indicators can immediately show which band corresponds to the feedback frequency, allowing sound engineers to reduce gain in that band to quickly kill the feedback while having minimal impact on the sound of the live program material. The FDC also acts as a simple spectrum viewer while the concert proceeds showing where the "hot" areas are. During system setup and sound check, FDC may be used to help identify room and sound system resonances. By increasing the gain until feedback, it is easy to identify those frequencies that are likely to be problems. Reducing the gain in these bands helps tune the sound system, and, remove problem areas before the show begins. It also helps increase the gain margin before feedback.

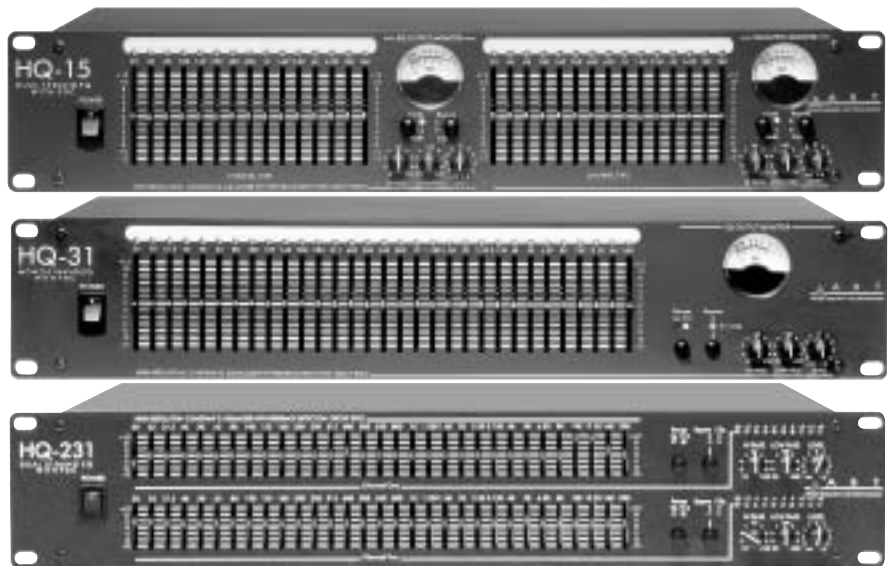

	441	442	451	452	455	HQ15	HQ31	HQ-231
Frequency Bands (ISO spacing)	2x15, 2/3 oct.	2x15, 2/3 oct.	31, 1/3 oct.	1x31, 1/3 oct.	2x31, 1/3 oct.	2x15, 2/3 oct.	1x31, 1/3 oct.	2x31, 1/3 oct.
Filter Type	Constant-Q -3% Center Accuracy							
Slider Travel	20mm	60mm	20mm	60mm	20mm	45mm	45mm	20mm
Range (Selectable)	+/-6dB or +/-12dB							
Input/Output Connections	Active balanced XLR and 1/4" TRS {XLR pin 2/ 1/4" tip = Hot (+)} Unbalanced RCA							
Input Impedance (Bal/Unbal)	24kΩ/12kΩ	24KΩ/12KΩ	24kΩ/12kΩ	24KΩ/12KΩ	24kΩ/12kΩ	20KΩ/15KΩ	20KΩ/15KΩ	20KΩ/15KΩ
Maximum Input Level	+22dBm	+22 dBm	+19dBm	+22 dBm	+19dBm	+22 dBm	+22 dBm	+22 dBm
Output Impedance (Typical)	<150Ω	<150Ω	<150Ω	<150Ω	<150Ω	<150Ω	<150Ω	<150Ω
Max. Output Level	+22dBm	+22dBm	+19dBm	+22dBm	+19dBm	+22dBm	+22dBm	+22dBm
Frequency Response (+/-5 dB)	20Hz - 20kHz	20Hz - 20kHz	20Hz - 20kHz	20Hz - 20kHz	20Hz - 20kHz	20Hz - 20kHz	20Hz - 20kHz	20Hz - 20kHz
THD + Noise	0.01%	0.01%	0.01%	0.01%	0.01%	0.01%	0.01%	0.01%
Signal to Noise Ratio	-94dB	-94dB	-94dB	-94dB	-94dB	-94 dB	-94 dB	-94 dB
Channel Separation	>50dB		>50dB					
Size (HWD)	1.75 x 19 x 7"	7.5 x 19 x 3.5"	1.75 x 19 x 7"	7 x 19 x 3.5"	3.5 x 19 x 7"	8.5 x 19 x 3.5"	8.5 x 19 x 3.5"	7.5 x 19 x 3.5"
Weight	7.5 lbs.	7.5 lbs.	7.5 lbs.	7.5 lbs.	12 lbs.	4.5 lbs.	4.5 lbs.	12 lbs.

AVALON

VT-737SP

PROCESSORS

224

Pure Class A, Vacuum Tube Discrete Preamp, Opto-Compressor and 4-Band EQ

The Vt-737sp is a high-quality recording channel that combines a Class A vacuum tube preamplifier, vacuum tube opto-compressor and discrete parametric equalizer — all of the essential elements needed to

provide a musical direct recording path to the input of your audio recorder or DAW. Only the best active and passive components available are used in the Vt-737sp including 4 military-grade vacuum triode tubes integrated into a minimal signal path with 100% discrete, high-bias pure Class A audio amplifiers. Twenty-two sealed silver relays are employed providing hard-wire bypass and multiple routing options for total creative control and minimum signal degradation. Balanced XLR inputs are available for both mic and line-level signals as well as an XLR output with a balanced DC coupled output amplifier. A high impedance 1/4" instrument input jack is also provided on the front panel allowing direct connection of a guitar or bass.



FEATURES

Vacuum Tube Design

- ◆ Combination of a tube preamp, opto-compressor, sweep equalizer, output level and VU metering in a 2U space nineteen inch welded steel chassis
- ◆ Allows you to amplify, control, and shape a signal from its source and deliver the signal directly to the input of your audio recorder or DAW completely bypassing the mixing console and its sonic limitations
- ◆ 4 dual triode vacuum tubes (Sovtek 6922), high-voltage discrete Class A with a 10 Hz to 120kHz frequency response ± 0.5 dB
- ◆ Twenty-two sealed silver relays employed for signal routing and (hard-wire) bypass switches, provide the most direct signal path and allow signal to pass through the unit when power is turned off
- ◆ An LCD display shows the number of hours that the tubes have been operating
- ◆ 150W toroidal shielded power transformer
- ◆ Switchable AC power supply 100-240V
- ◆ To ensure that there is no strain on the electronic components when the unit is activated, a "soft-start" feature slowly brings the unit to life when the unit is powered on

Mic Preamp

- ◆ The Mic Preamp stage employs a high voltage vacuum tube design that can be used for all types of dynamic and condenser mics, Hi-Z instruments such as guitars and basses, and for line level devices such as keyboards, mixers, recorders or DAWs
- ◆ Three different devices can be connected simultaneously and easily selected with the input mode switch on the front panel
 - > A high performance XLR balanced mic input transformer with switchable +48v phantom power
 - > A high impedance (one meg ohm) unbalanced 1/4" jack located on the front panel allows an instrument such as a guitar or bass to be connected directly to the tube preamp
 - > Discrete high-level Class A balanced line input
- ◆ A High gain switch, available to all inputs, boosts overall preamp gain and can be used to increase weak input signals or to achieve a wide range of distortion effects ranging from loose tube overdrive to tight discrete distortion
- ◆ A passive variable high pass filter and phase (polarity) reverse are available for all inputs and are, hardwire relay bypass switchable

Opto-Compressor

- ◆ The compressor uses a minimum signal path design and features twin Class A vacuum tube triodes for gain matching. The passive optical attenuator, used for gain reduction, serves as a simple yet musical level controller
- ◆ Continuously variable threshold level, ratio, attack, and release controls provide a variety of useful dynamic effects, from soft compression to hard-knee limiting
- ◆ To provide maximum flexibility, the compressor can be positioned either before or after (Pre/Post) the equalizer
- ◆ For even greater sonic possibilities, the two sweepable mid-EQ bands can be side chained to the compressor allowing a broad range of spectral control including de-essing
- ◆ A hardwire relay bypass switch engages the compressor into the signal path
- ◆ Stereo linking (tracking) between two VT737SPs is possible via an unbalanced 1/4" link jack on the rear panel



For Any Inquiries Regarding Your Order, Call Our Customer Service:
(800) 221-5743 • (212) 239-7765 • FAX: (800) 947-2215 • (212) 239-7549

AVALON

VT-737SP

4-Band Passive-Active EQ

- ◆ The four-band parametric equalizer section features a 100% discrete high voltage class A design with both variable-active and switched-passive filter topologies
- ◆ The High and Low Mid frequency bands each feature active peak/dip filters each with a boost and cut of ± 16 dB as well as a Q switch which allows you to select the appropriate bandwidth (Medium or Wide)
 - > The low-mid frequency is variable between 35 to 450 Hz
 - > The high-mid frequency is variable from 220Hz to 2.8 kHz
- ◆ The low frequency passive shelving EQ is selectable between 15, 30, 60 and 150 HZ with a boost and cut of ± 24 dB
- ◆ The high frequency passive shelving EQ is selectable between 10, 15, 20 and 32 kHz with a boost and cut of ± 20 dB
- ◆ As previously mentioned, the High and Low Mid band EQs can be assigned to the compressor's side chain circuit. When this is the case, the low and high EQ's are still available for tonal adjustment

Metering

- ◆ The high quality analog VU METER is switch selectable to indicate line output level or gain reduction for the compressor (**0 VU= +4dB**)
- ◆ The VU meter's needle is also speed sensitive for measuring gain reduction which helps in setting the ATTACK and RELEASE of the compressor
- ◆ A recessed screwdriver adjustment is provided for calibrating the VU meter to 0dB when set to read the compressor's gain reduction

Output Section

- ◆ The final output stage utilizes yet another dual triode vacuum tube driving a 100% Class A, high-current balanced and DC coupled low noise output amplifier
- ◆ A continuously variable trim pot lets you control the output level (-40dB to +10dB with center detent at 0dB)

Pre Amplifier Controls	
Preamp GainLine	-20 to +10dB (+18dB with gain boost)
Preamp Gain Instrument	-30 to +10dB (+28dB with gain boost)
Preamp GainMic	0 to +40dB (+58dB with gain boost)
Input Source Select	Line XLR balanced, unbalanced 1/4" Instrument jack, Mic XLR balanced
Input Mode Switches	
High gain	Adds +8dB to Line level signals and +18dB to Mic or Inst signals
Phase	Inverts the polarity of all 3 input sources
+48v	Phantom power to XLR Mic input
Passive Filter	6dB per octave passive bass cut filter variable from 30Hz to 140Hz
Compressor Controls	
Threshold	-30dB to +20dB
EQ to COMP	Places the EQ pre the compressor
Meter	Selects gain reduction (in) or output (out) metering
Ratio	1:1 to 20:1
Compress Switch	Engages compressor into signal path
Attack	Variable from 2ms to 200ms
Release	Variable from 100ms to 5 sec
4-Band Equalizer Controllers	
Bass (Passive Shelf):	
Boost/Cut	± 24 dB with center detent at 0dB, Shelf response
Frequency Range	4-position switch (15 / 30 / 60 / 150 Hz)
Low Mid (Active Peak-Dip):	
Boost/Cut	± 16 dB with center detent at 0dB, Peak-dip response
Frequency Range	Variable from 35 to 450 Hz or 350 to 4.5k Hz w/ x10 switch engaged
Bandwidth (Q)	Switchable for Narrow (Q=0.5) or Broad (Q=0.2)
High Mid (Active Peak-Dip):	
Boost/Cut	± 16 dB with center detent at 0dB, Peak-dip response
Vari frequency	Sweepable 220 to 2.8k Hz or 2.2k to 28k Hz w/ x10 switch engaged
Bandwidth (Q)	Switchable for Narrow (Q=0.5) or Broad (Q=0.2)
Treble (Passive Shelf):	
Boost/Cut	± 20 dB with center detent at 0dB, Shelf response
Frequency Range	4-position switch (10 / 15 / 20 / 32 kHz)
EQ to SC:	Routes the mid band EQ sections into the compressor sidechain for de-ess, effects and frequency selective compression
Output Gain:	45dB to 20dB
Inputs and Outputs —	
Hi-Z Instrument DI	Unbalanced (1 meg ohm) 1/4" input on front panel (+30dB max input level)
Mic Input	Active Balanced XLR (850/2500 ohm) with a maximum input level of +30dB
Line Input	Active Balanced XLR (20k ohms) with a maximum input level of +36dB
Line Output	DC-coupled, electronically balanced XLR discrete Class A on rear panel with a maximum output level of +30dB into 600 Ω
Compressor Link	Unbalanced 1/4" jack for stereo linking the compressor sections of 2 Vt-737SPs

System Performance

Frequency Response (-2.5dB)	10Hz to 120kHz input filter included
Frequency Response -3dB	1Hz to 200kHz line in-out
Noise (20kHz Bandwidth)	-92dB unweighted
Noise Microphone EIN	-116dB, 22Hz to 22kHz unweighted
Distortion THD, IMD	0.5%

AVALON

VT-747SP

PROCESSORS

226

Class A, Vacuum Tube-Discrete Twin Signal Path Opto-Compressor / 6-Band Program Equalizer

The Vt-747sp is a pure Class A, stereo opto-compressor and program equalizer that delivers unmatched routing flexibility and creative control for input signal conditioning, stereo mix bus and mastering applications.



The Vt-747sp's TSP (Tube Signal Path) design gives you a choice of warm tube processing with three hand selected vacuum tubes in the signal path or you can bypass the tubes and switch to classic Class A discrete transistor sound. The passive six band graphic equalizer offers gentle tone shaping combined with the two-band parametric EQ, assignable to the sidechain in the compressor section, provide complete spectral and musical control. Like all Avalon products, the Vt-747sp is hand built in the USA using only the finest active and passive electronic components available. A "no compromise" approach in every stage of design and production ensures that the Vt-747sp will give many years of dependable high-quality service.

FEATURES

Overview

- ◆ Combines a stereo tube/ discrete Class A optical compressor and a musical six-band program equalizer with separate output level and gain reduction metering and an internal regulated power supply — all in a 2U space nineteen inch welded steel chassis with rugged stainless steel metric hardware
- ◆ Ideal for high performance DAWs, input signal conditioning, stereo buss processing, stereo keyboard tracking as well as mastering applications
- ◆ Features a "no compromise" high voltage, high current, minimum signal path design with 22 sealed silver relays for all signal routing and hard-wire bypass functions
- ◆ 150W toroidal shielded power transformer
- ◆ The AC power supply is switchable for 50/60Hz, 100-240V operation
- ◆ To ensure that there is no strain on the electronic components when activated, a "soft-start" feature slowly brings the unit to life when the unit is powered on

TSP - Twin Signal Path

- ◆ The TSP (Tube Signal Path) gives you the choice of either tube tone (utilizing three high-voltage dual triode tubes), or the classic, Class A discrete transistor sound (utilizing discrete transistor amplifiers) in the primary opto buffers and output stages

Input Stage

- ◆ The input stage provides +36dB of headroom before overload
- ◆ A continuously variable trim knob controls the input level of the signal source. A wide range of sounds and colors can be achieved simply by varying the input level — In tube mode, the harder you drive the input, the more tube tone, can be sent into the compressor. In discrete mode (TSP disengaged) driving the transistors harder will achieve a more classic discrete transistor sound
- ◆ A +10dB Gain switch can be used to (overdrive) the input signal, or in a more utilitarian fashion, for matching low level sources such as keyboards and synthesizers

Opto-Compressor

- ◆ Compression is achieved by twin optical attenuators that act as passive level controllers. The opto-compressor design was chosen because it provides the most musical compression control
- ◆ The compressor section is immediately followed by a Class A amplifier with a variable gain control that provides up to +10dB of gain make-up
- ◆ Full dynamic control from soft compression to hard-knee limiting can be achieved with variable threshold, compression ratio, attack and release controls as well as a hard-wire bypass

Spectral Control

- ◆ Parametric Low and High frequency (LF and HF) spectral contour controls can be routed into the on-board side-chain path on the compressor for enhanced frequency dependent compression, such as de-essing. Variable frequency and threshold level controls are provided independently for the Low and High frequency
- ◆ An SC LISTEN switch allows you to monitor the signal going into the Side Chain before it is effected by the compressor



Rear view of the Vt-747sp



For Any Inquiries Regarding Your Order, Call Our Customer Service:
(800) 221-5743 • (212) 239-7765 • FAX: (800) 947-2215 • (212) 239-7549

AVALON

VT-747SP

6-Band Graphic Equalizer

- ◆ Extremely smooth and musical — The six frequency bands and corresponding Q settings have each been carefully chosen to provide the most natural harmonic balance and lowest phase change while offering simple and effective tone control
- ◆ The EQ's passive filter was designed to allow you to subtly shape and color the sound source while still keeping the signal musically balanced
- ◆ 100% discrete, Class A high voltage transistors are employed to ensure optimum sonic performance
- ◆ The EQ section is controlled by six faders with center detents and can be hard-wire bypassed
- ◆ The EQ can be routed pre or post the compressor providing greater creative flexibility and sonic capabilities

Inputs & Outputs

- ◆ Fully balanced inputs and outputs with XLR connectors are driven by DC coupled, Class A discrete amplifiers that provide +36dB input headroom

Metering

- ◆ A high quality analog VU meter indicates accurate gain reduction
- ◆ A fast-acting blue LED illuminates when peak gain reduction begins to occur
- ◆ Twin LED meters provide a 60dB range with fast L-R output status of all levels

System Performance

Noise 20-20kHz unweighted	-92dBu
Distortion (THD, IMD) @ 1kHz	0.5%
Bandwidth (-3dB)	1 to 200kHz
Frequency Response	10 to 40kHz +/-0.2dB

<i>Input Stage</i>	
Input Gain Trim	-20dB to +8dB detent at 0dB (+18dB with +10dB IN)
+10dB switch	Boosts input amplifier by +10dB for extra tube over-drive
TSP Twin Signal Path Switch	Swaps between tube and discrete Class A amp topology
<i>Opto-Compressor Controls</i>	
Threshold	Variable from -30dB to +20dB
Attack	Variable attack from 2mS to 200mS
Release	Variable from 100mS to 5S
Ratio	Variable from 1:1 to 20:1
EQ to COMP	Inserts the six (6) band EQ pre the compressor
Compressor Switch	Engages compressor into signal path and offers hard-wire bypass
Make-Up Gain	Variable from 0dB to +10dB
<i>Sidechain Controls</i>	
Side-Chain	Inserts spectral EQ into sidechain
<i>Spectral Sweep Frequency Controls</i>	
LF	60Hz to 1kHz
HF	600Hz to 10kHz
<i>Sidechain Threshold Controls</i>	
LF Threshold Range	-15dB to +15dB, detent at 0dB
HF Threshold Range	-15dB to +15dB, detent at 0dB
SC Listen Switch	Inserts Spectral EQ signal into audio path for monitoring
<i>Six Band Passive Class A, Program Equalizer</i>	
Fader 1 (Low-Bass)	±24dB boost/cut @ 15Hz shelf
Fader 2 (Mid-Bass)	±8dB boost/cut @ 125Hz peak-dip
Fader 3 (Low-Mid)	±4dB boost/cut @ 500Hz peak-dip
Fader 4 (Mid-Range)	±dB boost/cut @ 2kHz peak-dip
Fader 5 (Presence)	±10dB boost/cut @ 5kHz shelf
Fader 6 (Treble)	±20dB boost/cut @ 32kHz shelf
EQ Switch	Engages 6 band passive EQ and offers hard-wire bypass
<i>Metering</i>	
Blue LED	Indicates compressor speed and activation of compressor
High quality VU meter	Indicates gain reduction 0dB to -20dB
Recessed VU Adjust	Screwdriver adjust for 0dB when meter is switched for gain reduction
Fast LED Output Meter	Indicates both L-R spectral content and output level -30dB to +30dB
Output Level	Stereo output level control -20dB to +6dB detent at 0dB
<i>Inputs and Outputs</i>	
Left and Right Line Inputs	Balanced XLR for line level signals to +36dB maximum
Left and Right Line Outputs	Balanced XLR DC coupled, capable of +30dB into 600 Ω

Avalon systems utilize 100% discrete, high-bias pure Class A audio amplifiers. These pure Class A amplifiers are incorporated into minimal signal path designs which include sealed silver relays, balanced DC coupled high-current "outside-world" drivers, fully discrete linear DC regulators, low noise toroidal power transformers and selected high quality active and passive components. This powerful combination of

- ◆ Pure Class A Discreet Amplifiers - no op amps
- ◆ Bipolar symmetrical design - mirror image components
- ◆ Conductive plastic potentiometers

design features gives increased musical headroom and greater dynamic transient capability for a truly transparent audio passage. Avalon microphone preamplifiers have been in use around the world since 1986. All preamplifiers share the combined technologies of low ratio transformer balanced inputs coupled with high-voltage cascade FET twin bipolar discrete class A amplifiers.

- ◆ 100% discrete, Pure Class A signal amplifiers, practical user features and rugged hardware designed to deliver true high performance audio for many years

AVALON

M5 • AD2022

Mono & Dual Mono Pure Class A Preamplifiers

The AD2022 and M5 are world-class discrete Class A preamplifiers designed to realize the full potential of all microphones as well as electric instruments. Both preamps feature advanced high-performance transformers that deliver smooth detailed highs,

delicate liquid midrange and extended low frequency control. They are the perfect front-ends for analog tape and digital audio workstations (DAW's).

The AD2022 represents Avalon's fourth generation of fully discrete, symmetrical Pure Class A microphone preamplifiers with dual matched channels and several additional features, including selectable microphone source loading for optimized cable/mic matching, $\pm 3\text{dB}$ fine output trim controls, ultra high operating headroom $+36\text{dB}$ as well as balanced and unbalanced outputs.

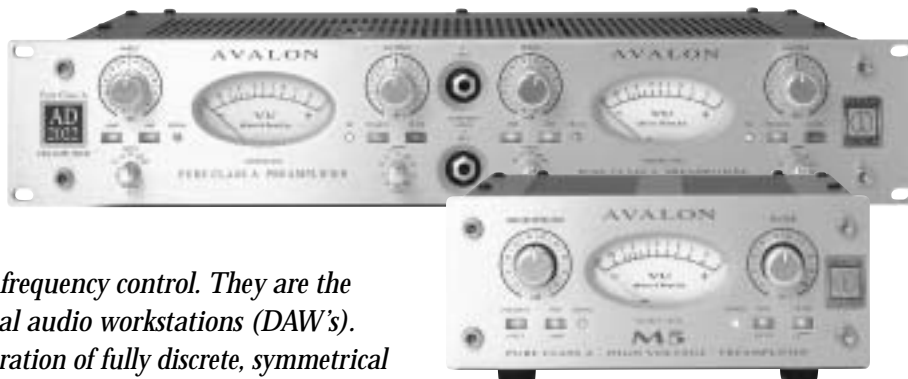

FEATURES

Symmetrical Pure Class A Design

- ◆ 100% discrete, high-voltage, symmetrical Pure Class A signal amplifiers are utilized for each channel — The first amplifier operates in a cascaded-cascode FET configuration while the second stage amplifier is fully bipolar. The twin amplifiers share the total available gain requirement. This shared architecture increases the high level headroom capability, improves transient response and doubles the internal bandwidth of the ultra-high performance pure Class A signal amplifiers
- ◆ The most advanced high-performance mic transformer available — Split low-ratio primary windings are carefully combined within a custom mu-metal core for extended smooth frequency response and very low distortion

Input Stage

- ◆ Input gain is variable from $+20\text{dB}$ to $+64\text{dB}$ in 4dB steps
- ◆ A switchable passive high pass filter, (6dB/oct, variable from 30Hz to 185Hz)

Microphone Input

- ◆ -20dB resistive pre transformer input attenuator (pad), $+48\text{v}$ regulated phantom power (50mA capability) and a Polarity reverse switch are available on the microphone input
- ◆ To ensure minimal signal invasion, sealed silver relays are used for all signal routing including the input signal selector, high pass filter, polarity reverse, $+48\text{v}$ power and the 20dB pad

Inputs

- ◆ XLR mic inputs are electronically balanced with a maximum input level of $+36\text{dB}$ (with -20dB pad)
- ◆ $1/4"$ Hi-Z instrument DI is provided with a maximum input level of $+18\text{dB}$ at 100k Ω

Metering

- ◆ Large, high-quality, illuminated analog VU meters provide accurate signal readings
- ◆ Bi-color LED's offers peak indication – green at 0dBu and red at $+20\text{dBu}$

Output Section

- ◆ High-current DC coupled, Class A discrete amplifiers are provided for the outputs of both the M5 and AD2022
 - > The M5 features an XLR unbalanced output with $+30\text{dB}$ capability into 600 Ω
 - > The AD2022 features an XLR balanced output with $+36\text{dB}$ capability into all known loads
- ◆ The AD2022 also features a $\pm 3\text{dB}$ variable fine output gain adjustment that can be used for gain riding during tracking

Power Supply

- ◆ The external B2T toroidal AC power supply is switchable for 100V to 240V, 50-60Hz operation, 150 watts maximum

Input Source Load Selector (AD2022 Only)

- ◆ A 5-position rotary switch, on each of the channels, enable you to change the preamplifier's input impedance between five different input impedance values: (DI), 50, 150, 600 and 1.5k Ω (MIC)
- ◆ This transformer balanced input load selector is provided as a "creative tone shaper" that can enhance the sonic signature of your microphones and cables — As you lower the input impedance you place a load on the microphone and cable the effect of which can create subtle to dramatic changes in frequency and distortion characteristics as well as filtering effects due to cable capacitance

AVALON

M5 • AD2022

Specifications	M5	AD2022
	<i>Preamp Controls</i>	
Input (Gain Control)	+20dB to +64dB in 2dB steps	Variable from +20dB to +64dB in +4dB steps
Output Level Control	-	Variable ±3dB (Fine Adjustment)
	<i>Passive High Pass Filter</i>	
Filter Frequency Control	6dB per octave continuously variable from 30Hz to 185Hz	
Filter (In)	Engages the high pass filter	
	<i>Microphone Input Only</i>	
Switchable Phantom Power	+130v and +48v regulated 50mA capability	+48v regulated 50mA capability
-20dB Switchable Pad	Resistive pre-transformer	
Input Source (impedance)	Transformer balanced low-ratio 1.5k Ω (fixed)	Transformer balanced low-ratio, 50, 150, 600 and 1.5k Ω (MIC)
Switchable Polarity Reverse	✓	✓
	<i>Metering</i>	
VU meter	High quality, illuminated analog VU meter indicates the output level in dB. Calibrated: +4dBu = 0 VU	
Output Peak LED	Bi-color LED flashes green at 0dBu (peak) and red at +20dBu (clip)	
DC (Power Indicator)	Blue LED indicates the DC power is operational.	
	<i>Inputs and Outputs</i>	
1/4" Hi-Z Instrument DI	Unbalanced, +18dB at 100k Ω	
XLR-Balanced Mic Input	+36dB (with -20dB passive attenuator)	
XLR Unbalanced Line Output	DC coupled, +30dB max. output into 600 Ω	
XLR-Balanced Line Output	-	DC coupled, +36dB maximum into 600 ohms
B2T Power Connection	XLR-4 cable connects to the power connector of the external	
B2T power supply	External B2T toroidal 100V to 240V, 50-60Hz selectable, 150 watts max	

M5 System Performance

Frequency Response -3dB	1 to 120k Hz transformer limit
Noise EIN Unweighted	-126dB 150 ohm.
Noise 20kHz Unweighted	-100dB
Distortion THD, IMD	0.05% nominal
System Bandwidth	DC to 1MHz

AD2022 System Performance

Frequency Response -3dB	1 to 120k Hz transformer limit
Noise EIN Unweighted	-126dB 150 ohm.
Noise 20kHz Unweighted	-102dB
Distortion THD, IMD	0.05% nominal
System Bandwidth	DC to 1MHz

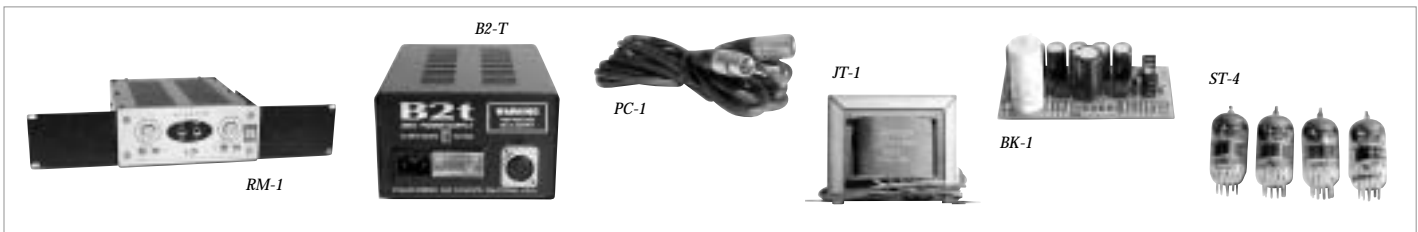

RM-1
Converts a single U5 or M5 to a standard 19" rack system. Includes two steel rack ears and eight stainless steel screws**69.95**

RM-2
Joins two U5 or M5's together in an standard 19" rack. The RM-2 contains two stainless steel rack ears, two T-bars, and ten stainless steel screws**99.95**

VP-1
1U 19" vent/spacer panel, ideal for cooling large racks.....**79.95**

B2-T
External AC power supply 100v-240v selectable.....**99.95**

PC-1
Four pin, low voltage power supply cable for AD2000 series 8' length**69.95**

JT-1
High performance Jensen (JT-11-BM) output transformer option (M5 only)**69.95**

BK-1
Special 130v option power supply plug-in card for B&K microphones (M5 only).....**149.95**

ST-4
Spare tube kit for VT-737SP and VT-747SP. Includes 4 matched military 6922 tubes.....**79.95**

AVALON

AD2044

Dual Mono-Stereo, Pure Class A Opto-Compressor

The AD2044 combines Avalon's legendary 100% discrete, pure class A signal amplifier design with custom designed high speed current monitored optical control elements.

These "invisible" opto elements enable the AD2044 to deliver totally

transparent, low noise gain reduction within the minimalist signal path design. Variable attack and release controls plus side chain access, provide unlimited creative control from soft compression to hard limiting. The perfect solution for two buss music-program compression, mono bass, instrument and mastering applications.



FEATURES

Sonic Excellence

- ◆ Combines advanced electronics with unequaled sonic excellence — The advanced true symmetry design offers high-voltage, large headroom, extended bandwidth and very low noise
- ◆ State-of-the-art, balanced 100% discrete, Pure Class A signal amplifiers offer the serious music professional unlimited sonic character and a natural harmonic detail that enhances the program material and becomes one with the music itself
- ◆ Low noise Pure Class A optical-compressor designed to optimize absolute signal integrity and musical performance
- ◆ Practical "real-world" user features and rugged hardware designed to deliver true high performance audio for many years
- ◆ The perfect solution for two buss music-program compression, mono bass and instruments and mastering applications

Linear Optical Compression

- ◆ Custom manufactured, high speed linear opto elements are used to create a non invasive passive attenuator system that ensures transparent gain reduction
- ◆ A unique external control loop and current monitored optical driver is incorporated that provides smooth control plus the benefits of traditional vintage LDR (Light Dependent Resistor) compression

Compression Controls

- ◆ Dual mono or stereo operation via Stereo Link switch
- ◆ Fully variable threshold, ratio, attack and release controls
- ◆ Hard-wire relay bypass for compressor in-out

Inputs & Outputs

- ◆ XLR-balanced inputs and outputs
- ◆ XLR-balanced sidechain input for spectral dynamics control

Metering

- ◆ Fast acting blue peak compression LEDs
- ◆ Large professional VU meters

Opto-Compressor Controls	
Threshold	Variable -24dB to +20dB
Ratio	Variable 1:1 to 20:1
Attack	Variable 0.5mS to 150mS
Release	Variable 80mS to 5 seconds for 12dB release
Bypass	Hard-wire relay bypass for compressor in-out
Link Switch	Large illuminated push switch for stereo L-R linking
Make Up Gain	Variable 20dB range (± 10 dB), center detent 0dB
Side-Chain (In)	Engages side-chain input
Switchable VU Metering	
Gain Reduction Meter	Illuminated gain reduction meter 0dB to -20dB range
Output Meter	Professional moving coil type -20dB to +3dB (0VU=+4dB)
XLR Balanced Inputs and Outputs	
Maximum Input Level	+30dB balanced
Maximum Output Level	+32dB balanced 600 ohms, DC coupled
Side-Chain Input	XLR balanced
Power Supply	B2T External AC supply, 150w toroidal transformer, 4 pin cable 90v isolated, 100-240v selectable 50/60Hz, 150w max

System Performance

Noise 20kHz Unweighted: -94dB (compressor in)
Distortion THD, IMD: 0.5% (typical 0.05% at +6dB 1kHz)
Frequency Response: -3dB 1Hz to 450kHz (input band limited)

Dual Mono, Pure Class A Parametric Music Equalizer

The Avalon AD2055 is a dual mono, four-band parametric equalizer combines 100% discrete, pure class A signal amplifiers with state-of-the-art passive and active filter topologies to give the serious music professional unlimited sonic character and a natural harmonic detail that is sure to enhance any program material. The AD2055's unique circuitry will breathe life into musical performances offering very high resolution transient detail at the operational extremes with very low noise at all settings. Avalon's true symmetry design offers high-voltage and high headroom (+32dB output) with an extended bandwidth from 1Hz all the way up to 500 kHz.



FEATURES

- ◆ Extremely musical and easy to use dual four band equalizer
- ◆ State-of-the-art, balanced 100% discrete, Pure Class A amplifiers
- ◆ High resolution transient detail
- ◆ Ultra low noise (-94dB) design optimized to provide absolute signal integrity and musical performance at all settings.
- ◆ High headroom +30dB
- ◆ Fully balanced DC inputs and outputs using XLR connectors
- ◆ Auto bias DC servo loop control eliminates the need for all interstage capacitor coupling
- ◆ Conductive plastic potentiometers for low noise
- ◆ All signal routing with sealed silver relays
- ◆ Perfect for stereo buss music-program equalization, special instrument EQ and FX applications as well as ultra high performance mastering studio applications
- ◆ External 150W toroidal BT-2 power supply provides clean, hum-free power (100-240v selectable 50/60Hz.)

System Performance

Noise 20kHz Unweighted -94dB (EQ in)
 Distortion THD, IMD
 0.5% (typical 0.05% at +6dB 1kHz)
 Frequency Response -3dB 1Hz to 450kHz
 (input band limited)

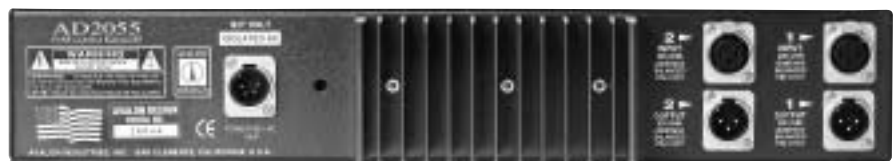

Transparent Passive-Active Filter Design

- ◆ Passive high and low bands plus two fully parametric mid bands deliver truly musical performance with high speed transient detail at the operational extremes
- ◆ The passive high and low bands are powerful and full-bodied with up to ±32dB of boost/cut for the low band and ±26dB of boost/cut for the high band and 10 frequency selector switches chosen for their sweet sound and musical performance
- ◆ Full bandwidth twin mid bands provide variable frequency selection (X10 frequency multipliers for very wide range), variable Q (width) and amplitude control

<i>Passive High and Low Bands Plus Two Fully Parametric Mid Bands</i>	
Bypass	Hard-wire relay bypass for equalizer in-out
Low band F1	Passive, ±32dB boost/cut, shelf or peak-dip curve
F1 frequency range (Hz)	Switched 10 position 18, 25, 30, 50, 72, 100, 150, 215, 300, 450
Mid band F2	Active, ±16dB boost/cut, peak-dip curve
F2 frequency range	Variable 35Hz to 450Hz (x10) 350Hz to 4.5kHz, Q (width) 0.3 to 3.0
Mid band F3	Active, ±16dB boost/cut, peak-dip curve
F3 frequency range	Variable 160Hz to 2k0Hz (x10) 1k6Hz to 20kHz, Q (width) 0.3 to 3.0
High band F4	Passive, ±26dB boost/cut, shelf or peak-dip curve
F4 frequency range (Hz)	Switched 10 position 1.5k, 2.5k, 3.5k, 5k, 7.2k, 10k, 12.5k, 15k, 20k, 25k
XLR Balanced Inputs and Outputs	
Maximum Input Level	+30dB balanced
Maximum Output Level	+32dB balanced 600 ohms, DC coupled
Power Supply	B2T External AC supply, 150w toroidal transformer, 4 pin cable 90v isolated, 100-240v selectable 50/60Hz, 150w max

AVALON

U5

Mono Instrument DI & Preamplifier

The U5 is a high-voltage DI-preamp that combines a unique passive tone selector with a variable gain preamp and filter. The variable gain Class A preamplifier is designed to optimize low level pick up signals with absolute signal integrity. The high input impedance accepts a wide variety of signal levels and instruments from acoustic guitars to high-output active bass guitars and keyboards. A high level speaker input is also provided for capturing the live sound from an instrument amplifier.



FEATURES

Input Stage

- ◆ State-of-the-art, 1/4" high impedance (3,000,000 Ω) input stage ensures zero load effect on sensitive pickups and keyboards
- ◆ A 1/4" high level (400 watt) speaker input on the rear panel, is provided for capturing the live sound of an instruments amplifier
- ◆ A variable gain Class A preamplifier can boost low level pickup signals to +30dB
- ◆ The active-to-thru switch selects either the instrument input directly or sends the boosted-equalized signal to the amplifier via the front panel jack
- ◆ A high-cut switch eliminates unwanted acoustic pickup and high frequency noise
- ◆ A rotary Tone control switch is provided with six passive EQ curves specifically designed to enhance a variety of acoustic and electric instruments including bass, guitar and keyboards

Outputs

- ◆ A headphone monitor amp with a 1/4" output connector is included for personal listening
- ◆ Twin DC coupled Class A output amplifiers drive both low level microphone preamp inputs and high level +4dB inputs for direct to tape recording or processing
- ◆ A rear panel ground isolation switch eliminates any possible earth loop or AC buzz problems with complete safety

Deep and Controlled Bass

Avalon U5 DI-preamps have been in use around the world since 1995. They have found their way into the world's leading musicians rigs and recording sessions and been featured on thousands of the best selling (and sounding) albums and live performances.

Six Position Tone Selector

This rotary switch lets you choose from 6 passive filters optimized for use with a variety of acoustic and electric instruments.

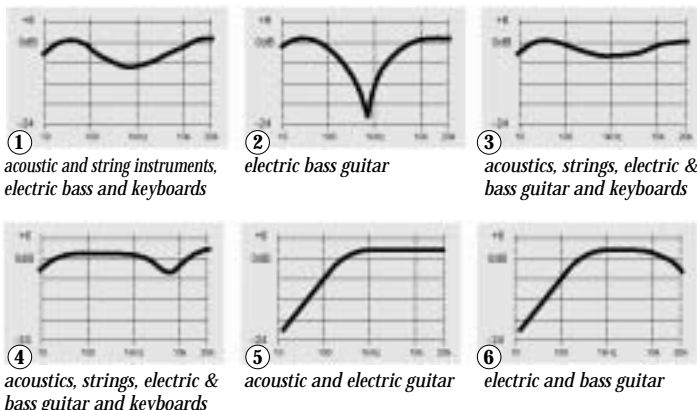

Gain	Switched 3dB steps, maximum gain +30dB
Switchable High Cut Filter	-3dB at 8kHz minimum phase design
Tone Selector	Six position rotary switch, all passive filters
Inputs and Outputs	
Instrument Input	1/4" high impedance DI
Maximum Input Level	+24dBu unbalanced, 400w speaker
Mic Output	150Ω Electronically-Balanced XLR
Line Output	600Ω Electronically-Balanced XLR
Maximum Output Level	+30dBu DC coupled, balanced 600 Ω (mic and line out)
Headphone Output	0.5w into 600 ohms
Ground Lift Switch	
AC Power	Internal toroidal AC supply

System Performance

Noise 20kHz Unweighted	-100dBu minimum gain position
Distortion THD, IMD	0.1% at +10dB
Frequency Response	5Hz to 100kHz (±0.5dB)
Frequency Response (-3dB)	1Hz to 500kHz (input band limited)
Rack mount kit (1) RM-1	Single U5 19" rack mount kit (holds one half rack unit)
Rack mount kit (2) RM-2	Dual U5 19" rack mount kit (holds two half rack units)



For Any Inquiries Regarding Your Order, Call Our Customer Service:
(800) 221-5743 • (212) 239-7765 • FAX: (800) 947-2215 • (212) 239-7549

BEHRINGER

MIC2200 ULTRAGAIN PRO

2-Channel Tube Mic Preamp/Line Driver/DI Box

The MIC2200 is the ideal extension to your console, MIDI setup or hard disk recording system. Integrated EQs give you extra sound-shaping power, while its built-in tube adds warmth and transparency to your signal. Also features direct injection and level conversion functionality.



- ◆ Mic input stages are based on high quality, discrete conjugate transistor pair circuitry
- ◆ Ultra-wide bandwidth from 2Hz to 200 kHz
- ◆ Built-in high-quality vacuum tube for outstanding, ultra-musical tube sound, warms up your music without unwanted noise
- ◆ Two parametric EQs with user adjustable center frequency, bandwidth and level
- ◆ Independent line driver to convert -10 dBV into +4 dBu pro level
- ◆ Completely versatile DI-Box due to servo-balanced inputs and outputs
- ◆ Tunable and switchable 12dB high-pass filter
- ◆ 'Soft Mute' 48v phantom power avoids power-on "thumps"; Phase Reverse switch
- ◆ 12-segment LED metering for output level
- ◆ Servo-balanced gold-plated XLR and 1/4" TRS inputs and outputs

T1953 TUBE ULTRAGAIN 2-Channel Tube Mic/Line Preamp



The T1953 has everything you need in a high-quality preamp; discrete input stages, input gain adjustment, phantom power, sweepable high-pass filter and a phase inversion switch. Plus you can add exactly the amount of tube warmth you want—without adding noise or sacrificing audio quality.

- ◆ Mic input stages are based on high quality, discrete conjugate transistor pair circuitry. Gain is adjustable from +10 to +60 dB
- ◆ Ultra Tube circuitry warms music without unwanted noise; "Warmth" control lets you add the amount of tube sound you want.
- ◆ High pass filter can be swept from 15Hz to 350Hz to eliminate floor rumble from mics and to tighten up tape tracks in line mode
- ◆ High quality detented potentiometers and switches with authentic vintage style knobs; stylish "retro" design with polished front panel
- ◆ Ultra-wide bandwidth from 18Hz to 30kHz
- ◆ Back-lit, analog VU and "warmth" meters; accurate metering for output level
- ◆ Servo-balanced gold-plated XLR and 1/4" TRS inputs and outputs.
- ◆ 'Soft Mute' 48v phantom power; phase reverse

VX2496 ULTRA-VOICE PRO Mic Preamp and Voice Processor

The VX2496 is a channel strip designed to meet all your vocal processing needs. With a mic preamp, compressor, expander/gate, EQ, de-esser and tube emulation in a single rack space, it's not only the perfect tool for direct-to-disk recording, but also for demanding live situations. It also offers AES/EBU output with selectable 44.1/48/88.2 and 96kHz sampling rates or external clocking.



- ◆ Discrete ultra low-noise mic/line input stage with soft mute 48v phantom power
- ◆ Authentic tube emulation circuitry for typical tube and tape saturation sounds
- ◆ RMS expander for smooth noise reduction
- ◆ Opto compressor for inaudible level control and creative sound processing
- ◆ Integrated dynamic enhancer replaces high frequencies lost through compression'
- ◆ EQ specially designed for voice enhancement
- ◆ Opto de-esser for removal of excessive sibilance from your vocal track
- ◆ Accurate LED metering; precision potentiometers; illuminated switches
- ◆ Servo-balanced, gold-plated XLR and 1/4" TRS inputs and outputs

BEHRINGER

MDX1600 • MDX2600 • MDX4600

Autocom Pro-XL • Composer Pro-XL • Multicom Pro-XL

Behringer's Pro-XL Series feature several innovative circuit designs that place it at the forefront of dynamics processing technology—at home in the studio or live. The MDX1600, MDX2600 and MDX4600 feature Behringer's revolutionary IKA (Interactive Knee Adaptation) circuit that

successfully combines the “hard knee” compressor circuit with the “soft knee” characteristic. They implement the IGC (Interactive Gain Control) peak limiter that cleverly combines a clipper and program limiter. You'll find the IRC (Interactive Ratio Control) expander that automatically changes its ratio settings with the program material for ultra-musical and inaudible noise suppression. A switchable low contour filter prevents “pumping”, while Behringer's IDE (Interactive Dynamic Enhancer) specifically makes up for the compression-induced loss of treble energy—assuring brilliant, lively audio even with heavy compression.

PROCESSORS

234

- ◆ Low contour filter prevents “pumping” due to low frequency dominated compression
- ◆ Stereo couple function with independent output level settings
- ◆ Low-noise amplifiers and state-of-the-art THAT VCAs guarantee best audio possible
- ◆ High-quality detented ALPS potentiometers and illuminated switches
- ◆ Servo-balanced, gold-plated 1/4” and XLR inputs and outputs (switchable for +4 dBu or -10 dBV operation)
- ◆ Separate 12-segment (8-segment on the MDX4600) LED meters for input/output levels and gain reduction.
- ◆ Interactive Dynamic Enhancer (adjustable on the MDX1600)
- ◆ Automatic or manually adjustable attack and release times (MDX1600/2600 only)
- ◆ Switchable side chain input with side chain monitor function (MDX1600/2600 only)
- ◆ The MDX1600 has a de-esser while the MDX2600 has a switchable VAD (Voice Adaptive) de-esser that differentiates between male and female voices.
- ◆ The MDX2600 incorporates ATS (Authentic Tube Simulation) to simulate tube circuitry for extra warmth and transparency.

T1952 TUBE COMPOSER

2-Channel Tube Compressor/Gate/Peak Limiter

The T1952 features an IKA compressor/limiter with switchable Auto function for automatic attack and



release time adjustment, IRC expander/gate and IGC program/peak limiter, selectable compression modes, switchable side chain input, stereo link, selectable operating level – and adds 12AX7 tubes and Ultra Tube circuitry, allowing you to sweeten and personalize your sound by adding the desired amount of harmonics.

- ◆ The desired effect of warm, silky enhancement is usually generated near the level of saturation of the tube circuit. That's when the additional harmonics are generated that give tubes their distinctive sound or personality. Behringer's Ultra Tube circuitry overcomes the level of dependencies traditionally associated with tube circuitry while eliminating virtually all hiss, noise and hum.
- ◆ “Warmth” control smoothly blends the additional harmonics into the signal without having to maintain a specific amplitude as you normally would with traditional vacuum tubes. This allows the desired sound to be achieved without running the risks of overheating or breakdown that occur when tubes are driven at maximum levels. Dial in as much tube sound as you want.
- ◆ Highly accurate metering for input/output level and gain reduction



For Any Inquiries Regarding Your Order, Call Our Customer Service:
(800) 221-5743 • (212) 239-7765 • FAX: (800) 947-2215 • (212) 239-7549

BEHRINGER

DYNAMIC PROCESSORS

	MDX2600	MDX1600	MDX4600
Channels	2	2	4
Stereo couple	Yes	Yes	Yes
Servo-balanced input / output	Yes	Yes	Yes
1/4" TRS + XLR connectors	Yes	Yes	Yes
Hard bypass	relay	switchable	switchable
Low contour filter	Yes	Yes	Yes
Ext. side chain	Yes	Yes	—
In / out meter	12-digit LED	12-digit LED	8-digit LED
Voice-adaptive de-esser	adjustable (Male/female switch)	auto	—
Dynamic Enhancer	auto	adjustable	auto
Tube simulation	Yes	—	—
Compressor / limiter			
Envelope	auto + manual	auto + manual	auto
Characteristic	IKA / "hard knee"	IKA / "hard knee"	IKA / "hard knee"
Gain red. meter	12-digit LED	12-digit LED	8-digit LED
"Traffic light" threshold indicator	Yes	Yes	—
Expander / gate	Yes	Yes	Yes
Fast / slow release time	Yes	Yes	Yes
Switchable exp. / gate function	Yes	Yes	Yes
Threshold LED indicator	Yes	Yes	Yes
Peak limiter	Yes	Yes	Yes
Limit LED indicator	Yes	Yes	Yes

DSP9024 ULTRA-DYNE

Digital 2-Channel Tube Compressor/Limiter/Gate /Peak Limiter

The ultimate 6-way Multiband Dynamics Processor for analog and digital mastering and sound reinforcement systems, the DSP9024 has more functions than you can imagine. Sound spectrum split into six separate frequency bands. Edit effect parameters with each band or globally. Parameter settings can be stored, copied, etc. Smooth compressor, super-clean gate, incredibly transparent Noise Reduction system and rich Multiband Exciter. Tube emulation and an integrated delay for "look-ahead" parameter adjustment. Finally, interactive signal analysis and unique automatic functions enable you to get results fast, whether you need multiband compression, loudness maximization, de-essing or selective gating. Add digital inputs/outputs with the optional AES/EBU interface.



The ultimate 6-way Multiband Dynamics Processor for analog and digital mastering and sound reinforcement systems, the DSP9024 has more functions than you can imagine. Sound spectrum split into six separate frequency bands. Edit effect parameters with each band or globally. Parameter settings can be stored, copied, etc. Smooth compressor, super-clean gate, incredibly transparent Noise Reduction system and rich Multiband Exciter. Tube emulation and an integrated delay for "look-ahead" parameter adjustment. Finally, interactive signal analysis and unique automatic functions enable you to get results fast, whether you need multiband compression, loudness maximization, de-essing or selective gating. Add digital inputs/outputs with the optional AES/EBU interface.

- ◆ 24-bit A-D/D-A converters for ultra-high dynamic range and resolution of detail with selectable sampling rate of 44.1 or 48 kHz
- ◆ Sophisticated tube emulation with selectable tube types (12AX7 or EL34)
- ◆ 6-band compressor/limiter with gate and peak Limiter for "inaudible" compression.
- ◆ 6-band Noise Gate with IRC for ultra musical performance.
- ◆ Ultramizer adjusts output level and signal density for maximum perceived loudness
- ◆ "Look Ahead" automatic parameter adjustment via internal 600-msec. delay
- ◆ 3-band Harmonics Exciter with user-definable balance
- ◆ Full MIDI parameter and snapshot control allow for real time editing
- ◆ Level peak meter with peak hold and selectable levels (+4 dBu, -10 dBV, Dig Max)
- ◆ 100 settings can be stored under any alphabetic name giving you instant sound results for numerous standard applications
- ◆ Extremely flexible Stereo Link, Band Link & Clone functions
- ◆ Large high-resolution LCD graphic display
- ◆ Relay-controlled hard-bypass with an auto-bypass function during power failure
- ◆ "Virtuoso" function for super-easy, program dependent and self learning program setup
- ◆ Gold-plated XLR and 1/4" RF-suppressed, servo-balanced inputs and outputs
- ◆ Optional 24-bit AES/EBU interface for digital inputs/ outputs at 32, 44.1 and 48 kHz

BEHRINGER

XR2000 INTELLIGATE • XR4400 MULTIGATE PRO



2- and 4-Channel Expander/Gates

The XR2000 was designed to fulfill the highest demands and offers maximum signal control. Voice-over applications, creative envelope shaping, noise suppression in quiet passages... No problem, especially with the transparent user interface and "traffic light" LED displays.

The XR4400 gives you four frequency-selective UTR expanders/noise gates in a single rack space without compromising on functionality. The side chains' parametric filters allow you to fine-tune control signals so that the gate reacts only when you want it to. Separate hold and release controls and the unique FlexLink system offer additional flexibility.

UTR Gate

Slow noise gates can rob your audio's brilliance by gating signals during the attack phase. UTR (Ultra Transient Response) circuitry with ultra-fast signal detectors prevents this from happening. Attack time is very short is very short; < 10 μ sec. (XR4400) and < 3 μ sec. (XR2000). Clicks or pops at the gating point (regardless of attack speed) are also eliminated by the low leakage of the control signal into the VCA's audio signal path.

IRC Expander

IRC (Interactive Ratio Control) expander virtually eliminates all switching noises. Even at ratio values above 1:8, they sound musical without side effects.

XR2000

- ◆ Integrated high-pass and low-pass filters for frequency-selective gating
- ◆ External side chain input with "key listen" function
- ◆ Attack, hold, release and ratio controls
- ◆ Maximum attenuation 100 dB
- ◆ "Traffic light" display for threshold working point
- ◆ Precise gain reduction display with 8 LEDs
- ◆ Servo-balanced XLR and 1/4" TRS inputs and outputs
- ◆ Relay-controlled hard bypass switch with auto bypass function in the case of power failures (safety relay)

XR4400

- ◆ Four separate expander/gate circuits
- ◆ IRC expander/UTR gate circuitries
- ◆ Extremely short attack time (<10 μ sec.)
- ◆ Parametric side chain filter with monitor function
- ◆ Maximum attenuation 80 dB
- ◆ Independent hold and release controls for flexible envelope shaping
- ◆ FlexLink system for flexible master/slave configurations
- ◆ Servo-balanced XLR and 1/4" TRS I/O
- ◆ "Traffic light" display for threshold working point and gain reduction display

PEQ2200 ULTRA-Q PRO 5-Band Parametric EQ

The PEQ2200 is an effective musical frequency correction and sound-shaping tool with center frequency, bandwidth and amplitude adjustment for each filter. Its state-variable, constant-Q filters and parallel filter configuration ensure musical operation, while overlapping frequency bands allow up to 30 dB of level correction.



- ◆ For gentle contouring and audio sweetening as well as for room equalization
- ◆ Constant-Q principle ensure absolutely stable filter characteristics
- ◆ Sweeplable High and Low Cut filters remove unwanted frequencies
- ◆ Bands are switchable in/out and fully adjustable from narrow notch filter (0.03 octave) to broadband EQ (2 octaves)
- ◆ A wide overlap between frequency bands allows for extreme cut or boost
- ◆ Cut-in delay to avoid switch-on "thumps"
- ◆ Relay-controlled Hard-Bypass with an auto-bypass function during power failure
- ◆ 12-segment LED input/output metering
- ◆ Servo-balanced, gold-plated XLR and 1/4" TRS input and output

BEHRINGER

T1951Q ULTRA-Q PRO

Dual Channel 4-Band Parametric Tube EQ

The T1951Q is a dual-channel, 4-band version of the PEQ2200 with state-variable, constant-Q filters, four fully parametric stereo bands with center frequency, bandwidth and amplitude controls, plus the option to use the low- and high-frequency bands as shelving filters. In addition, you get 12AX7 tubes and Ultra Tube circuitry, enabling you to selectively add tube warmth to your EQ'd signal.



GEQ3102 ULTRA-GRAPH PRO

Dual-Channel 31-Band Graphic EQ

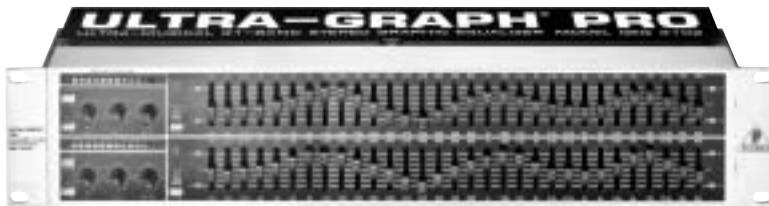

The GEQ3102 puts a powerful graphic EQ tool in your hands, with two channels of 31 standard 1/3 -octave center frequencies plus sweepable high- and low-pass filters for "pre-graphic" trimming. The dual 12-segment LED chains can display either input or output level, and each EQ section can be bypassed for quick comparisons.

- ◆ 2 x 31 ISO frequencies controllable via slide controls with boost/cut range switchable from 12 dB to 6 dB
- ◆ High-precision illuminated Alps faders

- ◆ 12-segment LED input/output metering
- ◆ High-quality detented potentiometers and illuminated switches

- ◆ Relay-controlled hard-bypass with an auto-bypass function during power failure
- ◆ Servo-balanced, gold-plated XLR and 1/4" inputs and outputs

DSP8024 ULTRA-CURVE PRO

Digital Dual Channel 31-Band Graphic/Parametric EQ

The DSP8024 features a 31-band graphic EQ with a real-time analyzer and an Auto-Q function for automatic room measurement and correction plus three bands of parametric equalization. Additional features include a peak limiter, an adjustable delay of up to 2.5 seconds (selectable in milliseconds, meter and feet), a noise gate and Behringer's renowned Feedback Destroyer. You can also add digital inputs/outputs with the optional AES/EBU interface (AES8024).

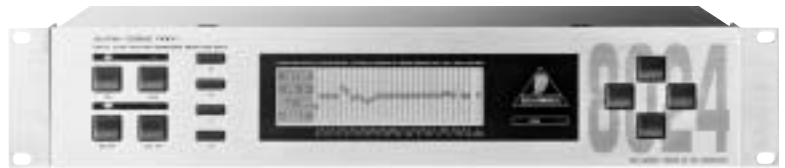

- ◆ High-end crystal 24-bit A-D/D-A converters for ultra-high dynamic range and resolution
- ◆ Ultra-musical 31-band graphic EQs with "True Frequency Response" characteristics
- ◆ Low / high / bell shelving tool with variable slope (3 to 30 dB)
- ◆ Precise real-time analyzer with peak hold, variable integration, cursor read-out and 10 user-memories for room equalization using mic input and internal noise generator.

- ◆ 6 bands of fully parametric equalizer/Notch Filter with up to 1/60th octave bandwidth
- ◆ "Feedback Destroyer" with intelligent signal analyzer for fast feedback suppression
- ◆ Integral digital Limiter protects against clipping and dangerous sound pressure levels
- ◆ Integral digital Noise Gate with Behringer's unique IRC (Interactive Ratio Control)
- ◆ Peak level meter with peak hold and selectable reference levels (+4 dBu / -10 dBV / Dig Max)

- ◆ Full MIDI parameter and snapshot control
- ◆ 100 user-memories
- ◆ EQ and analyzer curves may be copied, compared, added or subtracted
- ◆ Crossfade between two settings and stereo link facility to synchronize both channels
- ◆ Relay-controlled hard-bypass with an auto-bypass function during power failure
- ◆ Servo-balanced XLR and 1/4" inputs/outputs

BEHRINGER

DSP1400P ULTRAMIZER PRO

PROCESSORS

238

Digital 2-Band Loudness Maximizer/Program Enhancer

The digital 2-band concept of the ULTRAMIZER

PRO allows separate, program-adaptive compression and limiting for low and high frequencies, ensuring ultimate punch and loudness. Its surround processor and 2-band enhancer give your mixes that extra gloss, while the noise reduction system keeps things clean. Full MIDI capability allows real-time parameter control and program selection.



Full MIDI capability allows real-time parameter control and program selection.

- ◆ Doubles the loudness of recordings or reinforcement systems without any distortion
- ◆ Maximizes signal energy with absolutely "inaudible" and transparent compression
- ◆ Variable band-split compression eliminates gain modulation effects like 'bass pumping'
- ◆ Leveler provides constant average output while maintaining instantaneous dynamics
- ◆ Denoiser and Exciter for noise-free and ultra transparent sound
- ◆ 3-D stereo sound processor provides spatial enhancement and improved stereo imaging
- ◆ 8-segment LED level and gain reduction meters for optimum performance
- ◆ Multiband brickwall limiter
- ◆ 50 user preset memories
- ◆ Servo-balanced, gold-plated XLR and TRS inputs and outputs



T1954 TUBE ULTRAFLEX

2-Channel Tube Multiband Sound Enhancement System

The T1954 features a flexibly adjustable

enhancer/exciter circuit for high-frequency processing, a bass processor with a special LC coil/cap filter for extra low-end punch and definition, and a surround processor for stereo image improvement. 12AX7 tubes and Ultra Tube circuitry let you add the silky brilliance and warmth of tubes to your audio.

- ◆ LC coil/cap filter produces authentic vintage "soft" and "tight" bass sounds
- ◆ High-quality detented potentiometers and switches with authentic vintage style knobs
- ◆ Huge back-lit analog VU meters and "Retro" design

EDISON EX1 *Stereo 3-D Processor with Correlation Meter*

The EDISON EX1 is an unbelievably powerful psycho-acoustic processor, which allows you to completely manipulate all spatial parameters of the stereo image – such as width and depth – in a way never before possible. You can widen or narrow the stereo spread, bring instruments to the front or move them to the background, and make corrections to the stereo image – even on a finished master. All with five easy-to-use knobs. Whether PA, studio, Hi-Fi or audio for video: everything sounds more natural and transparent.

The integrated correlation meter guarantees fool-proof control of mono compatibility. Frequency cancellation and undesirable phase deviations in the mono and stereo content of your audio material are immediately visible.



BEHRINGER

EX1200 ULTRABASS PRO

2-Channel Subharmonic Synthesizer

The *ULTRABASS PRO* generates musically consequential subharmonics that can be set to one or two octaves below the lowest frequencies present in the original signal. Based on waveform analysis, the generated tones harmonize perfectly with the original sound, giving you big, fat low end, while the integrated limiter effectively protects your system from overloading.



- ◆ Adds unbelievable bass power to sound system, perfect for discos, clubs, theatres, sport and aerobic studios and your HiFi system
- ◆ Digital synthesis based on waveform analysis generates ultra-low frequencies for driving subwoofers
- ◆ Waveform Processor musically restores low frequencies lost in the recording process
- ◆ Releases untapped sonic resources and adds power to instruments, vocals and mixed program material
- ◆ Dynamic Punch control adds breathtaking kick bass to your program material
- ◆ Switchable x-over splits off dangerous low frequencies from your club system
- ◆ Built-in Limiter
- ◆ Bass Mode control allows you to fade over from "ultra-low" to "punchy" bass sounds
- ◆ Separate subwoofer output
- ◆ Output level and gain reduction LEDs
- ◆ Servo-balanced gold-plated XLR and 1/4" TRS inputs and outputs

EX2200 DUALFEX PRO • EX3200 ULTRAFEX PRO

2-Channel Multiband Spatial Sound Enhancement Processors



Geared for use in smaller setups or clubs, video or Hi-Fi systems, the EX2200 and EX3200 are among the most popular psychoacoustics devices in the world. Features include a "Natural Sonic" processor that guarantees aural improvement and high-end transparency, and the integrated bass processor that works wonders for your audio's low end. In addition, their adjustable surround processor allows flexible widening of the stereo spatial effect.

The EX3200 adds a Noise Reduction system, hard bypass and XLR connectors.

- ◆ Gives your music that extra sparkle and makes your instruments or mixes stand out
- ◆ Releases untapped resources and details instruments, vocals and mixed program material
- ◆ Multiband concept for bass power and high frequency transparency
- ◆ "Natural Sonic" processor for ultra-musical sound improvement
- ◆ VSP (Variable Sound Processing) circuit for simultaneous Enhancer and Exciter process
- ◆ "Dual Mode" ultra-bass enhancer produces "soft" and "tight" bass sounds
- ◆ Surround processor provides real spatial enhancement and improved stereo imaging
- ◆ High-quality detent potentiometers and illuminated switches
- ◆ Servo-balanced 1/4" TRS and RCA inputs
- ◆ EX3200 Step-up Features
- ◆ Shift function allows you to control the frequency range of added bass punch
- ◆ Built-in Noise Reduction system with LED
- ◆ Solo facility for effect loop application
- ◆ Relay controlled Hard Bypass with an auto bypass function during power failure
- ◆ Servo-balanced gold-plated XLR and 1/4" TRS inputs and outputs

BEHRINGER

MULTI-EFFECTS PROCESSORS

PROCESSORS

240

Modulizer Pro (DSP1224P)

The DSP1224P puts tons of trendy stuff at your fingertips, like 8-voice chorus, spatial flanger, ring modulator and resonator. There are also LFO- and MIDI controllable moduleable filters with resonance, developed using physical modeling with analog filters as archetype as well as amp and speaker simulations, a 3D processor and much more.



- ◆ True stereo processing for open-sounding enhancement of the sound sources
- ◆ XLR and 1/4" TRS servo balanced inputs and outputs
- ◆ 100 user preset memories to store programs for instant recall
- ◆ Accurate eight-segment LED level meters simplifies settings
- ◆ Real-time parameter control and program selection via MIDI
- ◆ Cutting edge effects such as 3D Processor, Stereo Imager, Lo-Fi, Super Bass, Ring Modulator, Voice Canceled etc.
- ◆ 24 breathtaking effects such as Ultra Phaser, Jetstream Flanger, Auto Filter, Ultra Compressor, Guitar Combo, Speaker Emulation Resonator and more
- ◆ Hundreds of effect variations plus two individual parameters and separate low and high EQ section

VIRTUAL ROOMS

Have you ever heard an orchestra perform in a concert hall? The sound is all-enveloping, richly textured. However, did you know that the sound you hear in a concert hall or room is 90% reflected? Come into Behringer's "virtual rooms".

Some digital reverbs only give you a crude approximation of real acoustic reverb. Behringer's reverb algorithms are infinitely more complex and detailed. They have accurately analyzed the acoustic properties and taken physical measurements of real rooms, concert halls and theaters. Precise mathematical models are used to calculate the reverb algorithms. The accuracy of hundreds of parameters used in the physical modeling of real buildings which also includes the important determination "early reflections" ensure rich, dense and natural sounding reverberation. When you place an instrument inside one of Behringer's "virtual room" you don't get a muddy sound. You end up with realism, vibrancy, separation and a clarity you never thought possible from a digital device.

Virtualizer Pro (DSP2024P)



The DSP2024 Virtualizer Pro features 71 effect algorithms, giving you powerful modulation, amp simulation, distortion and special effects as well as effective dynamic and psychoacoustics processing

and equalization on top of Behringer's renowned wave-adaptive Virtual Room reverb algorithms. There are also 7 adjustable parameters plus high and low EQ per effect, 11 serial or parallel effect combinations, true stereo processing in stereo image with most algorithms and an improved user interface.

DSP2024 STEP-UP FEATURES

- ◆ Over 70 algorithms and special effects including Virtual Room reverb algorithms. Also includes dynamic and psychoacoustics processing algorithms, distortions, amp and tube simulations, sampler, vocoder and much more.
- ◆ 11 effect combinations using modulation effects like chorus, flanger, pitch or tremolo combined with reverb or delay algorithms.
- ◆ 7 parameters per preset plus separate high and low EQ section.



For Any Inquiries Regarding Your Order, Call Our Customer Service:
(800) 221-5743 • (212) 239-7765 • FAX: (800) 947-2215 • (212) 239-7549

BEHRINGER

AUDIO SOLUTIONS

DSP1124P Feedback Destroyer Pro 2-Channel Digital Feedback Suppressor/Parametric EQ

Powered by a 24-bit high-speed DSP the DSP1124P locates feedback frequencies immediately and sets extremely narrow notch filters to "destroy" them, leaving the remainder of the signal virtually untouched. With its various modes you can master just about any live sound situation or use it as a creative sound-shaping tool with 24 bands of fully parametric equalization.



- ◆ Automatically and "intelligently" finds and destroys up to 12 frequencies per channel
- ◆ "Set-and-forget" default setting enables immediate Feedback Destroyer performance
- ◆ Single-Shot mode automatically searches and destroys feedback and locks the filter until manually reset
- ◆ Auto mode continuously monitors the mix, resetting programmed filters automatically
- ◆ Select single-shot, auto or manual modes for each filter
- ◆ Manual mode allows individual settings of up to 2 x 12 fully parametric filters with frequency, bandwidth and gain
- ◆ 24-bit A/D and D/A converters
- ◆ Two software engines allow independent or coupled functions on left and right channels
- ◆ Accurate eight-segment LED meters
- ◆ Full MIDI capability
- ◆ Servo-balanced XLR and 1/4" TRS I/O

DSP110 Shark

Digital 24-Bit Multifunction Signal Processor

An all-round problem-solver, the DSP110 combines mic/line preamp (60 dB gain control, +48v phantom power) with a variety of signal processing options, including Feedback Destroyer, variable delay line for speaker time-alignment (up to 2.5 seconds of delay, adjustable in msec, meters or feet),



ultra-musical compressor with adjustable density and speed parameters, and an extremely fast automatic noise gate with

learn function and optional manual setting. Add 24-bit A/D and D/A converters, servo-balanced XLR and 1/4" inputs/outputs, mic/line level conversion, external power supply for maximum signal integrity and headroom, and you can use the DSP110 in just about any application.

- ◆ Status LEDs for all 12 filters
- ◆ 4-digit multi-function display
- ◆ 19" rack-mounting kit included with purchase of 5 DSP110s
- ◆ 6-segment clip level meter
- ◆ Subsonic filter with adjustable cut-off frequency

SNR2000 Multiband Denoiser



2-Channel Single-Ended Noise Reduction System

With true multiband detection in the side chain, IRC noise gates and TAC filter circuitry, the SNR2000 ensures smooth and effective noise reduction with minimal loss of audio integrity.

- ◆ Multiband frequency analysis and processing
- ◆ TAC (Transient Attack Control) dynamic filter circuitry responds to extremely fast attack signals
- ◆ Auto Filter for quick setup
- ◆ IRC (Interactive Ratio Control) downward expander "musically" removes any noise in pauses
- ◆ Noise reduction of up to 80dB
- ◆ Adjustable cut off frequency and release times meters
- ◆ Dual mono or stereo couple function
- ◆ Servo-balanced XLR and 1/4" inputs and outputs
- ◆ Relay controlled Hard Bypass
- ◆ Cut-in delay to avoid switch-on thumps
- ◆ Illuminated switches, 41 detent potentiometers

BEHRINGER

AUDIO SOLUTIONS

Troubled by feedback despite your best and knowledgeable efforts? Wondering how to tame that unruly, time-consuming studio wiring? Crossovers not cutting it anymore? Tired of accessories big on promises and short on performance? For each of these problems and more, Behringer has an answer.

Any performance can be plagued by feedback without warning. Fortunately, Behringer has the tools required to stop the problem instantly. In the world of professional audio, every second counts. Any time spent in a rat's nest of cabling, for example, figuring out how to get things hooked up and running, is definitely time better spent doing something else. Enter the Ultrapatch Pro patchbay and Ultralink Pro splitter/mixer.

SRC2496 Ultramatch Pro A/D and D/A, Sample Rate and Format Converter



If you frequently have to deal with various interfaces, digital standards and so on, you've probably discovered that compatibility doesn't always mean that your gear will harmonize perfectly. The SRC2496 Ultramatch Pro enables you to transfer digital audio signals between devices with different sample rates, formats or interfaces, disable SCMS for 1:1 digital copies and remove dropouts or jitter from digital media. Simultaneously operable outputs offer splitter functionality, and the 24-bit/96-kHz compatible SRC2496 offers A/D and D/A conversion as well.

- ◆ Format conversion between AES/EBU and S/PDIF (coaxial or optical)
- ◆ Converts 30 to 100 kHz sample rates into 32/44.1/48/88.2 or 96 kHz with selectable 16, 20- or 24-bit output resolution.
- ◆ Parallel A/D and D/A conversion at identical sample rate
- ◆ Removes jitter and corrects incorrect sample rates
- ◆ Universal sample rate synchronization via wordclock or digital input
- ◆ Allows direct manipulation of emphasis and copy-protection bits
- ◆ XLR, RCA and optical outputs are simultaneously operational, while inputs are separately selectable.

DI100 Ultra-DI Ultra-Rugged Single-Channel DI Box



The DI100 puts an end to hum and impedance problems, and ensures that any imaginable sound source (electric guitar, bass or keyboards etc.) will reach your mixing console balanced and noise-free. You can even plug your guitar amp's speaker output into the

DI100—it will deal with ratings of up to 3,000 watts and give you a perfect signal at the other end. In addition, OT-1 output transformers ensure clean, powerful output with ultra-flat frequency response.

- ◆ Input-buffering amp ensures clean, pure and powerful sound, even with extremely long cables
- ◆ Rugged metal housing with hard rubber corners for protection
- ◆ Internal battery gets de-coupled when you use phantom power
- ◆ Gold-plated XLR and 1/4" TRS connectors for input and link output

DI4000 Ultra-DI Pro Active 4-Channel DI Box



Ideal for stage and studio applications, the multi-purpose DI4000 gives you four first-class DI (Direct Inject) channels in one rack space. Capable of handling almost any kind of signal, the DI4000 is equipped with two inputs (XLR and 1/4" TRS), a balanced output (XLR) and a 1/4" link output per channel, up to 40 dB of switchable input attenuation and up to 20 dB of gain. In addition, OT-1 output transformers ensure clean, powerful output with ultra-flat frequency response.

- ◆ Allows direct connection to speaker outputs rated at more than 3000 watts
- ◆ Converts unbalanced line inputs to balanced outputs
- ◆ +20 dB gain switch for pre-amplification of low level signals
- ◆ Switchable high cut filter (8 kHz) for guitar applications
- ◆ Phase reverse switch
- ◆ Ground Lift switch eliminates typical ground loop problems
- ◆ Accurate eight-segment LED meter simplifies level settings
- ◆ Gold-plated XLR and 1/4" TRS inputs and outputs
- ◆ Switchable attenuation allows maximum input of +50 dBu

BEHRINGER

AUDIO SOLUTIONS

CX2310 Super-X Pro

2-Way Stereo/3-Way Mono Frequency Crossover with Subwoofer Out



The CX2310 offers absolute precision, state-of-the-art circuitry, professional components, ultra low-noise op amps, fully balanced in and outputs and intuitive operation. In addition to full-fledged 2-way stereo/3-way mono operation, the CX2310 features a separately adjustable subwoofer output, giving you an extra low-frequency band.

- ◆ World-class performance 24 dB per octave Linkwitz-Riley filters
- ◆ Absolute flat summed amplitude response, zero phase difference
- ◆ Separate subwoofer section with independent frequency control
- ◆ Individual output level controls for all bands; individual output mutes for easy band adjustment
- ◆ Individual phase reverse switches for instant phase correction
- ◆ Switchable 25 Hz subsonic filter on each input for low-frequency driver protection
- ◆ Servo-balanced, gold-plated XLR inputs and outputs
- ◆ Precision Alps potentiometers for accuracy and repeatability
- ◆ Illuminated switches for operation in dark stage environments
- ◆ Shielded toroidal mains transformer for minimal noise

CX3400 Super-X Pro

3-Way Stereo/4-Way Mono Frequency Crossover with Limiters



The CX3400 is an active frequency crossover enabling 2 or 3-way stereo or even 4-way mono operation. Each band features two 24-dB Linkwitz-Riley filters, as well as individual IGC limiters, while the integrated delay enables flexible time alignment. Polarity switches for each output allow quick and easy runtime compensation for various driver and horn types.

Same features as the CX2310 PLUS—

- ◆ Individual limiter on each output for loudspeaker protection
- ◆ “Low Sum” function provides low-level mono output for subwoofer operation
- ◆ Adjustable time delay for phase alignment between drivers
- ◆ Switchable equalization for constant directivity horns

PX2000 Ultrapatch Pro

48-Point Switchable Patchbay with 4 Modes



The PX2000 offers the reliability and flexibility you need to connect your entire studio in a clear, orderly fashion. With its four modes, easily selectable via topside switches, the patchbay's 24 jack pairs can operate in parallel, half normalized, normalized or open mode. High-grade components include metal housing, metal-ring jacks and fiberglass boards.

MX882 Ultralink Pro

8-Channel Splitter/Mixer,
Level Conditioner/Converter



This compact signal distribution wizard has helped countless musicians and engineers solve diverse problems, whether as a splitter, line mixer or level conditioner. Regardless of your application, the MX882 keeps your signal paths short and clean. And its multiple matching amplifiers allow you to convert home-recording level to professional level and vice versa. Use as effects mixer, for PA monitoring, live sound systems, theaters, conference rooms, hotels, churches, etc.

- ◆ Any channel can be selected either as mixer or splitter
- ◆ Use as 8-In/2-Out Line Mixer; as 2-In/8-Out Line Splitter; or as 6-In/6-Out Line Driver or DI-box
- ◆ Convert -10 dBV into +4 dBu or vice versa
- ◆ Extremely high headroom - offering more dynamic range
- ◆ Ultra-wide bandwidth from 2 Hz to 200 kHz for “open” sound
- ◆ 6 mono inputs/outputs, 2 main inputs/outputs with 6 input level controls, 6 balance/pan controls, a main input/output control
- ◆ Main Link switch allows routing of the main input to the Main Output to link several units
- ◆ 4 /8-segment LED metering for each individual gain section
- ◆ Servo-balanced gold-plated XLR and 1/4” TRS inputs and outputs

COMPRESSORS/GATES

266XL Dual Channel Compressor/Gate

The 266XL brings affordable, high-quality compression and gating with intuitive operation so you can easily smooth



uneven levels, add sustain to guitars, squash drums or tighten up mixes. Auto Attack and Release emulates the classic dbx compressors by continuously adjusting the attack and release times to optimally match the program material. Manual controls are also available, allowing you tailor the attack and release response specifically for individual tracks, mixed program material, special effects or system protection.

- ◆ Stereo or dual mono gating, compression
- ◆ Expander/Gate Circuit with variable release time and +15dBu maximum threshold.
- ◆ Advanced gate circuitry uses an automatic timing algorithm to produce ultra-smooth release characteristics—even with complex signals, such as voice or reverb decays
- ◆ Compressor/Limiter circuit with variable threshold and ratio controls as well as auto (program-dependent) or manual Attack and Release control.
- ◆ Selectable OverEasy/Hard Knee compression curves, depending if you're looking for "heavy" almost-special-effects compression or soft, smooth gain leveling.
- ◆ Sidechain Inserts enables an outboard processor to control compression or gating.
- ◆ RMS Level Detection senses the power in the program in a musical manner, for much better results than peak or average detection.
- ◆ 8-segment LED display for gain reduction (up to 30dB).
- ◆ In Stereo Couple mode, Channel 1's controls become the master, and Channel 2 follows precisely to ensure a rock solid stereo image, even with high amounts of compression
- ◆ Signal does not pass thru any of the parameter controls. Instead a DC voltage controls all functions, eliminating any possibility of potentiometer noise developing over time.
- ◆ Electronically-balanced XLR and 1/4" TRS inputs and impedance-balanced XLR and 1/4" TRS outputs

166XL Dual Channel Compressor/Gate



The 166XL steps up from the 266XL by adding two channels of PeakStop limiting to provide studios, sound reinforcement

companies, musicians, or anyone who needs quality processing quickly and easily—with complete control of signal dynamics. Most compressor/gates provide less than musical compression, coupled with gating that swallows transients—or closes early, cutting off decay and reverb tails. The superb engineering in the 166XL ensures that both its compression and gating provide versatility and excellent sonic performance in situations where other compressor/gates typically produce undesirable processing artifacts.

- ◆ Stereo or Dual Mono operation of gating, compression and PeakStop limiting.
- ◆ PeakStop Limiting provides control of maximum peak levels at the a channel's output regardless of any other control.
- ◆ PeakStop comes after the compression, gating and other circuitry including the output gain, so it sets an absolute limit for peak excursions before they reach the output.
- ◆ A Sidechain enable switch on each channel lets you activate or de-activate the Sidechain inserts without repatching
- ◆ A Contour button in the Sidechain Path prevents sustained low frequency program material from dominating the compressed signal. This allows faster attack times which preserve transients and allows higher compression ratios with less artifacts.
- ◆ Hardwire System Bypass Buttons on both channels allow the audio to pass even if the unit loses power — also useful for A-Bing the processed and unprocessed signals.
- ◆ 10-segment LED display for gain reduction (up to 30dB)
- ◆ Electronically-balanced XLR and 1/4" TRS inputs and outputs

COMPRESSORS/GATES

160A Compressor/Limiter

The latest generation of the legendary dbx 160 family of compressor/limiters, the 160A offers the



same classic sound, easy set-up and no compromise metering plus it has an improved signal path and stronger chassis design. Digital-ready and road tough, the 160A features switchable OverEasy and Hard Knee compression, extremely wide threshold ranges, and controls for ratio and output gain. It also includes true RMS level detection, providing the most natural-sounding dynamics processing available—from subtle compression to “brick wall” peak limiting. And with its unique “INFINITY +” inverse compression mode, the 160A actually decreases the audio output level below unity gain when the input exceeds threshold. Two 160As can be coupled to process a stereo mix without shifting the left/right image.

- ◆ Choose low ratios and OverEasy compression to transparently smooth out fluctuating vocal and instrumental levels. Or use the 160A's Hard Knee compression and high ratios (up to and beyond infinity:1 and over 60dB gain reduction) for bombproof protection against overload distortion in digital recording, PA systems and broadcast signals.
- ◆ 12-segment LED display for gain reduction up to 40dB
- ◆ 19-segment LED display for high resolution monitoring of true RMS input/output levels
- ◆ Input/output meter calibration allows the 160A to be used in a variety of situations where the 0 reference is not consistent
- ◆ Electronically balanced /unbalanced input and output stages are fully compatible with +4/-10dB. The output stage is an outstanding line driver for long cable runs.
- ◆ “INFINITY +” inverse-compression mode decreases the output level below unity gain when the input exceeds threshold — ideal for correcting overbearing vocal choruses or controlling runaway house mix levels.
- ◆ Detector input allows special applications including frequency conscious compression in which an external equalizer is used.
- ◆ Input Ground Lift Switch eliminates any ground loop hum problems that may arise.

Hard Knee vs OverEasy Compression:

When the compressor is set for Hard knee, the compression ratio applies only to signals above the threshold level. If the compressor is set for Soft knee (OverEasy), the compression ratio gradually increases from 1:1 to the current selected ratio over a range through the threshold area which allows the transition from uncompressed to compressed to be more gradual. This greatly reduces compression artifacts and allowing faster attack times and higher compression ratios while still maintaining the natural characteristics of the signal. Hard knee compression, on the other hand, is ideal for “brick wall” limiting because it stops any transients from slipping through without affecting lower level signals.

	266XL	166XL	160A
	<i>Expander/Gate Controls</i>		
Threshold Control Range	-60 to +10dBu	Off to +15dBu	N/A
Ratio Control Range	1:1 to 4:1	1.2:1 to 8:1	N/A
	<i>Compressor Controls</i>		
OverEasy Button with LED	Yes	Yes	Yes
Threshold Control Range	- 40dB to +20dB	- 40dB to +20dB	- 40dB to +20dB
Ratio Control Range	1:1 to ∞:1	1:1 to ∞:1	1:1 to ∞:1
Attack Time	Switchable; Manual and Automatic	Switchable; Manual and Automatic	Automatic
Release Time	Switchable; Manual and Automatic	Switchable; Manual and Automatic	Automatic
1/4" TRS Side Chain Insert	Tip = Input, Ring = Output	Tip = Input, Ring = Output	
Bypass Switch w/LED	Yes	Yes	Yes (Hardwire)
PeakStop Limiter Threshold Range	N/A	0dBu to +20dBu	N/A
Gain Make-Up Range	Variable; -20dB to +20dB	Variable; -20dB to +20dB	Variable; -20dB to +20dB
Stereo Couple	True RMS Stereo Summing	True RMS Stereo Summing	True RMS Stereo Summing (with 2nd unit)

COMPRESSORS/GATES

1066 Dual Channel Compressor/Limiter/Gate

Designed to provide simple, flexible operation for recording, broadcast or live sound reinforcement applications,



the 1066 steps up from the 166XL with several important features. At the heart of the 1066 is dbx's V2 VCA (voltage-controlled amplifier). The V2 offers superb dynamic range characteristics while maintaining very low distortion and almost immeasurable noise. This combined with its world-class design, enables the 1066 to perform like compressors selling for hundreds of dollars more. The 1066 also improves on the 166XL's limiter, with a PeakStopPlus limiter. In addition to simply preventing unwanted transients from blowing your speakers or causing digital clipping while minimizing the distortion common to many other "hard" limiters, PeakStopPlus offers a two-stage limiting process for more transparent control. The 1066 also adds a Side Chain Monitor button (SC Mon) that makes setting up and adjusting the Side chain much easier by allowing you to listen to the audio source inserted into the Side Chain. Last, selectable input and output metering helps determine that everything is matched up level-wise, maximizing signal-to-noise ratio.

SAME FEATURES AS THE 166XL PLUS—

- ◆ RF-filtered, gold-plated electronically-balanced/unbalanced inputs and outputs
- ◆ V2 VCA boasts superb dynamic range characteristics while maintaining very low distortion and immeasurable noise.
- ◆ 12-segment LED for gain reduction (up to 30dB)
- ◆ Side Chain Monitor (SC) function makes setting up and monitoring the Side Chain much easier
- ◆ Precision metering of input/output levels (between -24 and +18 dBu) with switchable 8-segment LED meters

PeakStopPlus Level Control

Applies fail-safe limiting using a unique two-stage process to control the output signal.

Stage 1 – Instantaneous Transient Clamp

This is a soft logarithmic clamp function that ensures that the signal doesn't exceed the threshold set by the PeakStopPlus level control by more than 2 dB (typically) and will not introduce harsh artifacts.

Stage 2 – Intelligent Predictive Limiting

This is a unique program limiter which monitors the input signal and intelligently predicts the amount of gain reduction needed to keep the output below the ceiling set by the Instantaneous Transient Clamp.

System Performance (same as 166XL except)

Dynamic Range	>120dB, unweighted
THD + Noise	<0.1% any amount of compression up to 40dB at 1kHz
Intermodulation Distortion	<0.1% SMPTE
Noise	<-95dBu unweighted, 22 kHz measurement bandwidth
Interchannel Crosstalk	< -100 dB, 20 Hz to 20 Hz

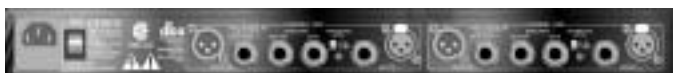

Input Specs	Impedance	Max. Input Level
XLR & 1/4" TRS	>50k Ω bal/>25k Ω unbal	> +24dBu (bal or unbal)
Side Chain Specs	Impedance	Max. Level
1/4" TS Input	>10kΩ	> +24 dBu
1/4" TRS Output	2k Ω bal/1k Ω unbal	+21 dBu (bal or unbal)
Output Specs	Impedance	Max. Output Level
XLR & 1/4" TRS	120 Ω bal / 60 Ω unbal	+21dBu into 600Ω

VCA	dbx V2
Side Chain Input	RF Filtered, unbalanced 1/4" TS
Side Chain Output	RF Filtered, impedance-balanced 1/4" TRS
PeakStop Plus Limiter	
PeakStop Plus Limiter	Two-stage limiter
Threshold Range	+4 dBu to >+22 dBu (off)
Stage 1	Instantaneous Transient Clamp
Attack and Release Time	Zero
Stage 2	Intelligent Predictive Limiting
Auto Attack Time	Program-dependent, typically <5 msec
Auto Release Time	Program-dependent, typically 22 dB/sec
Ratio	∞:1 (Fixed)
Output Gain Adjustment	20dB to +20dB
Stereo Couple Switch	Links channels as stereo pair
Bypass Switch	Hardwire bypass of all front panel controls

COMPRESSORS/GATES

1046 Quad Channel Compressor/Limiter

Equally at home in recording studios and live sound reinforcement venues, the 1046 provides 4 channels of pristine sound and smooth



classic dbx OverEasy or hard knee compression for a variety of applications from multitrack recorders to PA systems. Stereo coupling is independently selectable for channels 1 and 2 and channels 3 and 4 letting you configure the 1046 for 4 mono channels, two stereo pairs, or two mono and one stereo pair of processing.

Additionally PeakStopPlus is available to protect your system from the oppressive peaks that can take out valuable drivers in your sound reinforcement rig or studio monitors. So whether you need to control the level, placement in the mix, or overall characteristics of 4 independent signals or control the gain leveling on a couple of stereo pairs, the dbx 1046 is for you.

The 1046 offers the same features and specifications as the 1066 except that it has no manual Attack & Release and no Side Chain functions



1074 Quad Gate

The 1074 Quad Gate offers four dedicated and

independent channels of user selectable Noise gating in any combination including: dual stereo, or two mono and one stereo. Each of the 1074's four channels offers gating, threshold, depth and release controls, gold plated XLR inputs and outputs as well as a 1/4" key input that allows you to trigger the gates using an external audio source. And like 1046 and 1066, the 1074 is based on the legendary dbx V2 VCA. An internal variable filter allows frequency-selective control of each gate. The 1074 is ideal for a wide range of applications including gating dry and percussive sounds or sounds that have longer decay times such as cymbals and pianos, gating hum or buzz from live instruments or recorded tracks, or eliminating headphone leakage into microphones.



Input Specs	Impedance	Max. Input Level
XLR	>50k Ω balanced >25k Ω unbalanced	> +22dBu balanced or unbalanced
Key Input Specs	Impedance	Max. Input Level
1/4" TRS	50k Ω balanced 25k Ω unbalanced	-
Output Specs	Impedance	Max. Output Level
XLR	60 Ω balanced 30 Ω unbalanced	> +22dBu balanced > +20dBm unbalanced

VCA	dbx V2
Rear Panel Inputs & Outputs	
XLR Line	RF Filtered, Electronically-balanced / unbalanced switchable for either +4 dBu or -10 dBV operation
1/4" TRS Keyed Input	RF Filtered, Electronically-balanced / unbalanced
Gate Controls	
Filter Control	80Hz to 8kHz
Filter Switch	On/Off
Key Input Switch	On/Off
Stereo Couple Switches	Couples channels in stereo pairs. Channels One and Three become the master channels
Threshold Control	Off to +10dBu
Depth Control	
Release Control	0.01 seconds to 3 seconds

SILVER SERIES

376 Tube Channel Strip with 24-Bit/96kHz Digital Output

The 376 combines the warmth and tone of a vacuum tube mic preamp with a 3-band EQ,



compressor and de-esser along with analog and digital outputs to provide a versatile yet affordable "Front End" for any recording rig. The 376's AES/EBU and S/PDIF digital outputs feature selectable sampling rates up to 96kHz, and 24-bit selectable dithering and noise shaping. dbx's Type IV conversion system ensures that all of the analog warmth and detail is captured to digital tape or disk.

Insert

- ◆ An unbalanced 1/4" TRS insert (effects loop) permits connecting the 376 to an external processor. Insertion point is located after the tube section but before the signal processing section. The **tip** of the 1/4" TRS connector provides a SEND (100 Ω) while the **ring** is used as a RETURN (20k Ω)

Analog Outputs

- ◆ Electronically-balanced/unbalanced XLR (Pin 2 Hot) and 1/4" TRS analog outputs with level control range of ± 20dB.

Mic Preamps

- ◆ Drive control sets the amount of gain at the input of the tube stage and provides a broad range of sonic possibilities from subtle tube warmth to harmonically rich overdrive. Gain is variable from +30 to +60 dB for the mic input and ±15 dB for the line input.
- ◆ Mic preamp channels have access to selectable 48 volt Phantom Power, 20 dB Pad and Phase (polarity) reverse switches.
- ◆ A switchable 12dB/octave Low Cut Filter @ 75Hz is available for any input source — mic, line or instrument.

Compressor

- ◆ OverEasy or Hard Knee compression
- ◆ Threshold range control is variable from -40 dBu to +20 dBu. (Compression ratio is variable from 1:1 to infinity).
- ◆ Program-dependent Attack and Release
- ◆ Selectable Slow switch can enable a slower attack/release time— 15 ms for the Attack Time for 15 dB of gain reduction and 8 dB/sec for the Release Time

De-Esser

- ◆ A wideband variable gain reduction (compression) circuit and a selectable frequency control with a range of 800 Hz to 10 kHz High Pass are designed to suppress sibilance (hissing S or SH sounds) without affecting the desired frequency characteristics of the program material.
- ◆ Program-dependent release time is typically 12 dB/octave; 1 ms/dB

3-Band Equalizer

- ◆ 3-band EQ with high (12kHz) and low (80Hz) frequency shelving filters and sweepable mid-band (100Hz to 8kHz). Each band has a ±15dB boost/cut range

Metering

- ◆ LED metering is provided at each processing stage
 - 4-segment input drive signal meter
 - EQ Clip LED indicates that the EQ'd signal is clipping
 - Three stage compressor threshold meter
 - 8-segment Gain Reduction meter displays the amount of signal being attenuated
 - Two Stage De-Esser threshold meter
 - Meter Select Switch toggles between the digital or analog output signal displayed in the 8-segment LightPipe meter— analog levels are scaled to dBu while digital levels are scaled to dBFS (Full scale)

Built-in Digital Output (376/386)

Type IV Conversion System

dbx's Type IV Conversion System lets you transfer the depth and complexity tube processing directly to the digital domain via AES/EBU or coaxial S/PDIF digital outputs without the need for an external A/D converter.

- ◆ Proprietary analog and digital processing techniques capture a much wider dynamic range than an A/D converter could, preserving the maximum amount of information from the analog signal.
- ◆ TSE (tape saturation emulation) prevents digital distortion by remapping audio signals approaching 0dBFS to a built-in soft clipping and limiting algorithm that emulates the effect of tape saturation.

Selectable Dither and Noise-Shaping Algorithms

- ◆ Dither is random noise added to the audio signal to eliminate the harmonic distortion created by truncation (word length reduction). Three types of dither are available: TPDF, SNR2, or none
- ◆ The Noise-Shaping switch works in conjunction with Dither and allows you to select one of three psycho-acoustic noise-shaping curves: Shape 1, Shape 2 or none

Sync In and Out Connectors

- ◆ Internally terminated 75Ω BNC connectors are provided for word clock input and output allowing the processors to be used in a master or slave configuration
- ◆ dbx custom VCXO clock chips specifically designed for low-jitter performance
- ◆ World Clock signals of 96, 88.2, 48 or 44.1 kHz are supported

SILVER SERIES

386 Dual Channel Tube Mic-Preamp w/Digital Output

The Silver Series 386 is a stripped-down dual channel processor with the same tube mic pre and Type IV



conversion system as the 376. The 386 will accept mic, line and Hi-Z instrument inputs and its dual channel capabilities make it an ideal solution for dual mono or stereo tracking of vocals, instruments —miked or direct, as well as stereo keyboards and samples. The hand-selected 12AX7 tube lets you add just the right amount of tube warmth or even overdrive to any signal.

376 AND 386	
<i>Inputs</i>	
Rear Panel	Electronically-bal / unbal XLR Mic and 1/4" TRS line
Front Panel	High impedance 1/4" TS unbalanced instrument
<i>Vacuum Tube Mic Preamp</i>	
Input Drive Control Range	+30 to +60 dB (mic) & -15 to +15 dB Line
Insert	1/4" TRS (unbalanced) tip =SEND ring = RETURN
Analog Outputs	Electronically-bal / unbal XLR and 1/4" TRS
Output Level Control Range	-20 dB to +20 dB (Analog or Digital)
Digital Outputs	Coaxial S/PDIF (75Ω), XLR AES/EBU (110Ω)
Supported Sample Rates	96, 88.2, 48, or 44.1 kHz
Supported Word Lengths	24-, 20- and 16- bit
Word Clock Sync I/O	75Ω BNC (internally terminated)
Supported W/C Signals	96, 88.2, 48, or 44.1 kHz

376 ONLY	
<i>3-Band EQ</i>	
Low Frequency	80Hz Shelving w/ 15dB boost & cut
High Frequency	12kHz Shelving w/ 15dB boost & cut
Mid Frequency	Sweepable from 100Hz to 8kHz, ±15dB boost/cut
Mid Freq. Bandwidth	Fixed 1.5 octave
<i>Compressor</i>	
Threshold Control Range	Variable -40 dBu to +20 dBu
Ratio Control Range	Variable 1:1 to ∞:1
<i>Program-Dependent Attack and Release Times</i>	
Attack Time	Typically 5 ms for 15 dB of gain reduction
Attack Time (Slow)	Typically 15 ms for 15 dB of gain reduction
Release Time	Typically 50 dB/sec
Release Time (Slow)	Typically 8 dB/sec
<i>De-Esser with variable gain reduction (compression) circuit</i>	
High Pass Filter Range	800 Hz to 10 kHz
Program-dependent Release	Typically 12 dB/oct approx. 1 ms/dB

System Performance

Equivalent Input Noise	Typically -120 dBu with a 150 Ω source load,
Input Noise	20Hz to 20kHz
Analog Frequency Response	<10Hz to 75kHz
THD+Noise	0.35% typical at +4dBu out, 1kHz, 40 dB gain
Balanced Mic/Line CMRR	>40dB, Typically 55dB
Interchannel Crosstalk (386 only)	Typically -80dB, 20Hz to 20kHz

Input Specs	Impedance	Max. Input Level
XLR Mic Inputs	330 Ω balanced	-9 dBu or +11 dBu w/20 dB pad
1/4" TRS Inputs	40k Ω balanced	+21dBu
1/4" TRS Inputs	20k Ω unbalanced	+21dBu
1/4" instrument inputs	470k Ω unbalanced	+21dBu
1/4" TRS Insert Specs	Impedance	Nominal Level
Send	100Ω	
Return	20Ω	
Output Specs	Impedance	Maximum Output Level
XLR Outputs	120 Ω (balanced)	>+21 dBu, >+20 dBm*
1/4" TRS Outputs	120 Ω balanced	>+21 dBu, >+20 dBm*
1/4" TRS Outputs	60 Ω unbalanced	>+21 dBu, >+20 dBm*

* (into a 600Ω load)

Mini-Pre Single Channel Vacuum Tube Mic Preamp

The newest member of the Silver Series, the Mini-Pre incorporates the classic dbx tube microphone pre-amp sound in an easy to use, compact, affordable package. A single channel preamp, the Mini-Pre fea-



tures the same hand-selected 12AX7 vacuum tube to add warmth and tone to any microphone signal, selectable 48v phantom power, 20 dB Pad and Phase reverse switch, and peak LED.

- ◆ XLR microphone input
- ◆ 1/4" TS line input
- ◆ Balanced 1/4" TRS and XLR outputs
- ◆ Selectable +48 volt phantom power
- ◆ 20 dB Pad
- ◆ Phase reverse switch
- ◆ 60 dB gain and -infinity to +10dB of output level
- ◆ Peak LED

dbx

BLUE SERIES

PROCESSORS

250

The craftsmanship of the Blue Series is as stunning as the engineering is innovative. A striking blue front panel machined from 1/4" aircraft aluminum, hand-crafted solid aluminum knobs, LEDs mounted individually in machined stainless steel housings, custom VU meters with peak indicators, and heavy gauge chassis solidify the 160SL and 786 as the benchmark compressor and preamplifier for decades to come.

160SL Stereo Compressor with AutoVelocity Dynamics

Equipped with patented AutoVelocity technology, switchable Over Easy/hard knee compression, variable attack and release controls, Side Chain capability, and switchable PeakStop/PeakStopPlus limiting, the dbx 160SL is the standard



by which all compressors are measured. With AutoVelocity it is now easier than ever to dial up the exact attack and release. But the heart of the 160SL is its dual proprietary V8 VCA modules. This state-of-the-art implementation of dbx's original Blackmer decilinear VCA boasts an unheard-of 127dB dynamic range and ultra-low distortion. Encased in a specially designed aluminum-zinc housing for shielding and thermal characteristics, the V8 maintains its superior performance even in harsh environments.

The 160SL and 786 take full advantage of the most technologically superior components available today. Premium active electronics, precision 0.1% and 1% metal film resistors, great sounding temperature stable polypropylene capacitors, high-reliability board-to-board connectors with gold-palladium-nickel contacts, Jensen transformers, gold-plated Neutrik XLRs, rare earth magnet relays with gold contacts in a hermetically sealed nitrogen environment, military grade glass epoxy circuit boards, to mention a few, contribute to the most technologically advanced compressor and preamp in the world.

786 Precision Mic Preamp



The ideal companion to the 160S, the 786 is a two-channel precision preamp designed to provide the truest reproduction of the mic source as is electronically possible. In addition to an absolutely pristine audio path and the best pre-amp

features such as +48V phantom power, 20 dB pad, and phase invert functions, the 786 also includes a switchable "super low Z" setting which optimizes the pre-amp performance for microphones with very low source impedance. An 11-position coarse gain switch sets the gain between +10 and +60 dB, while the fine gain control varies between -3 and +3 dB. Levels may be monitored on peak-program VU meters with adjustable reference levels.

The signal path consists of a transformer-coupled, discrete-design premium input stage utilizing the proprietary dbx M8 mic pre-amp module. The minimum signal path design routes the amplified signal directly to a patented high output drive circuit. Each stage throughout the mic pre is small-signal square wave compensated to assure precise phase alignment at all audio frequencies.

The 786 also features a patented EQ circuit called "Spectrum" with frequency cut and boost up to 40kHz. A unique variable high-frequency equalization circuit employed in the mic pre-amp, Spectrum enhances the high frequency spectral content of the signal while maintaining phase integrity. The "Detail" control varies the amount of high frequency shelving boost at the frequency determined by the Spectrum control. The combination of the Spectrum and Detail controls allow pristine high frequency equalization adjustments without the added "hash" of traditional high-frequency EQ topologies.



ONE HOUR FREE PARKING

AT 349 W. 34th STREET (with purchase of \$100 or more)

The Blue Series Difference

±24V Power Supply Rails:

Most solid-state professional audio equipment has ±15 volt power supply rails. This is fine for most applications, but it isn't good enough for the Blue Series. They use ±24 volt power supply rails that allow higher headroom, which translates to greater dynamic range.

Triple Shielded Power Supply:

The Blue Series power supply was designed to overcome hum related problems typically found in power supplies. dbx started with a low-noise toroidal style transformer with a hum shield around it, then they added a second mu-metal can that encloses the entire transformer, and then mounted that in a separate steel power supply chassis. The result – no radiated hum into the rest of the circuitry.

Burr Brown Op Amps:

dbx uses the Burr-Brown (makers of the best and most expensive op-amps in the world) OPA2604 FET based op amp throughout the audio path. The OPA2604 boasts a distortion spec of 0.0003% THD at 1kHz. A FET based op amp has a more linear transfer function -- it generates less odd order harmonics than a bipolar designed op amp. This is one reason why the Blue Series sound is so transparent.

Patented High Drive and Low Distortion Output Circuitry:

This stage has patented circuitry to reduce the distortions introduced by an output transformer. This beefy output stage is capable of driving thousands of feet of cable to +30 dBu. Conventional 5532 op amp style output stages are good, but they don't come close to the performance of the Blue Series output stage.

Jensen Audio Output Transformers:

Output isolation transformers are essential for eliminating grounding problems in audio systems. Both the 160SL and the 786 have custom oversized Jensen output transformers along with patented circuitry that essentially nulls out the distortions caused by the transformer. What this means is that you get all the benefits of an audio transformer but not the problems of a transformer.

Jensen Audio Input Transformer:

The 786 uses the Jensen JT-16 mic input transformer. It has frequency response of 0.45 Hz to 220 kHz (-3dB down). It is encased in a 30dB magnetic shield to eliminate pickup of any hum. Couple this with a common-mode rejection ratio of 117dB at 60 Hz, and you have the best mic input transformer available.

dbx V8 VCA:

The heart of any compressor is the gain element. dbx took the original Blackmer-designed deci-linear VCA and made state-of-the-art improvements to come up with the V8 VCA. This VCA module boosts an unheard of 127dB dynamic range and ultra low 0.007% THD. Encased in a specially designed, aluminum-zinc housing (for it's shielding and thermal characteristics), the V8 maintains superior performance even in harsh environments.

Precision Potentiometers:

Grab and twist one of the pots on a dbx Blue Series product. You will immediately notice the nice damped response of these controls. We exclusively use expensive precision Alps potentiometers throughout on these products. These parts are extremely reliable and accurate.

Precision 0.1% and 1% Resistors:

To obtain the performance we desired in the Blue Series products, it was mandatory to use precision parts throughout the design. We specifically use all 0.1% and 1% precision metal-film resistors. This ensures that the response from unit to unit is always the same.

704X Optional 96kHz Digital Output for 786, 160SL and Quantum II

The 704X is the first 96kHz digital output system that offers a 48-bit internal signal processing path, and up to 24-bit digital output in either AES/EBU or S/PDIF formats. The 704X brings super high-end digital conversion to the top-of-the-line Blue Series processors.

Combined with the Blue Series means the 786 now has the ability to offer the industry's most pristine signal path in both analog AND digital, while the 160SL is now the most comprehensive analog compression system with digital output now available.

The 704X uses the patented TYPE IV Conversion System to convert your analog signals to digital in a way that preserves the analog warmth, yet gives the clarity and precision offered by the digital domain. Think about it, the warmth and smoothness of your analog signal, coupled with a digital system that offers the best performance in headroom management through custom dither algorithms and noise floor shaping. It really is the best of both worlds.

The 704X uses the patented TYPE IV Conversion System to convert your analog signals to digital in a way that preserves the analog warmth, yet gives the clarity and precision offered by the digital domain. Think about it, the warmth and smoothness of your analog signal, coupled with a digital system that offers the best performance in headroom management through custom dither algorithms and noise floor shaping. It really is the best of both worlds.



- ◆ 44.1/48/88.2 or 96kHz sample rate
- ◆ Dither outputs to 16, 20, or 24 bits using TPDF or SNR 2 algorithms
- ◆ 48 bit internal signal path for increased headroom and low level resolution
- ◆ Sync input/output using dbx's proprietary clock chips for extremely low jitter sync
- ◆ Two user selectable noise shape algorithms for lower perceived noise floor
- ◆ AES/EBU (gold-plated XLR) or S/PDIF

DDP

Digital Dynamics Processor



The DDP combines the precision, flexibility and extended parameter control of digital, with the warmth and musicality of analog, to offer superb gating, compression, limiting, de-essing and EQ. The DDP features a choice of true stereo or dual mono operation with ultra-wide range 24 bit A/D and D/A converters that utilize dbx's TYPE IV Conversion System featuring TSE (Tape Saturation Emulation). The LCD display uses a hybrid display technology that combines exceptional graphics, high resolution metering as well as character and icon based displays to show you all the information you need to know. Active effects in a entire setup are intelligently displayed in the form of a graphical curve making it a snap to set up even the most challenging of systems. 50 great factory preset setups are provided to help you get started while the DDP's operating system offers you the ability to refine and save presets to your liking then name and save them as your own presets for later recall. Digital input/output is also available as an option, giving you the ability to go all-digital. Full MIDI SysEx automation functionality makes the DDP one of the most versatile processors on the market today.

FEATURES

Processing Modules

- ◆ All of the classic dbx sounds are provided in gating, compression, limiting, de-essing, and sidechain EQ with precision control over every parameter
- ◆ Stereo Coupled (True RMS Power Summing) or dual mono operation
- ◆ Gate controls – threshold, ratio, attack, hold, release as well as a variable Transient Capture Mode
- ◆ Transient Capture Mode (TCM) controls the delay of an incoming audio signal up to 3ms. allowing the very beginnings of fast transient signals to be captured. This results in a smoother sounding signal which requires less aggressive processing in the compressor, limiter, and de-esser functions
- ◆ Delay time is variable from 0µs to 3ms in 1000th/sec increments
- ◆ Compression controls – threshold, ratio, gain, OverEasy with VariKnee, auto and manual attack, hold, and release modes
- ◆ OverEasy with VariKnee algorithm – lets you choose 1 of 10 knee slopes from soft to hard knee. With softer compression knees the compression ratio is gradually increased until the threshold is reached. This makes the transition between uncompressed and compressed signals as seamless as possible
- ◆ Limiting controls – threshold, attack and release
- ◆ De-esser controls – variable High Pass Filter and de-ess amount
- ◆ Sidechain / Inline EQ controls – 3-Band EQ with variable frequency and Q controls, ±12dB boost and cut, and Side Chain Monitor

Preset Management

- ◆ 50 factory presets & 50 user programmable presets that can be saved and recalled at any time
- ◆ Build your own presets using your favorite building blocks
- ◆ Change programs, parameters, and bypass via midi controllers
- ◆ "Building Block" style operating system lets you build and save your own presets

Controls

- ◆ Data Wheel – changes selected parameters, programs and modules
- ◆ Function Buttons – These backlit buttons activate programs, modules, utilities, and parameters

Metering

- ◆ 8-step analog input and output metering
- ◆ Hi-res graph shows composite output vs. input plot of audio signal

Type IV Conversion

- ◆ Ultra wide dynamic range 24-Bit A/D and D/A converters with TSE Tape Saturation Emulation
- ◆ TSE (Tape Saturation Emulation) is a process of giving a digital signal an analog-type sound or color, making it more pleasing to the ear. TSE lets you drive the input past the zero mark without risking digital overs. Instead, you get a pleasant saturation modeled after the sound of analog tape being saturated with signal.

Analog Inputs & Outputs

- ◆ XLR and 1/4" balanced ins and outs

Optional Digital I/O Card

- ◆ Provides 24-bit digital input and output capabilities in either AES/EBU or S/PDIF formats
- ◆ Supports 44.1 and 48 kHz sampling frequencies

MIDI In and Out/Thru

- ◆ Provides full MIDI functionality and automation via CC and Sysex
- ◆ Out/Thru jack allows you to use the DDP at any point in the MIDI chain

Hierarchy

- ◆ The DDP's hierarchy works on a "building-block" philosophy. Every program number consists of a processing "setup" which is built from a chain of processing elements. Chained elements consist of any or all of the following processors: expander/gate, compressor, limiter, parametric EQ, sidechain parametric EQ, and/or de-esser and each has a full complement of parameters that can be precisely manipulated via the Function buttons and the Data Wheel. Chain elements can be used in different combinations to produce a desired effect. Setups can be named and saved to the user library area.
- ◆ Several preset mono and linked setups are provided. Processing setups are linked together using True RMS Power Summing for superior stereo operation, or two separate setups may be used in dual mono mode.

Analog Inputs & Outputs

XLR and 1/4" TRS line	RF Filtered, Electronically-balanced / unbalanced compatible with +4dBu and -10dBv operation
Input Gain Range	-∞ to +16dB
Output Gain Range	-∞ to +16dB
Gate Controls	
Threshold Range	-75dB to 0dB
Ratio	1:1 to 1:∞
Attack Control	0.1ms to 200ms
Hold Control	0ms to 500ms
Release Control	360dB/sec to 5dB/sec
TCM	Transient Capture Mode Off/On
TCM Time Control	0μs to 3ms in 1000th/sec increments
Compressor Controls	
OverEasy Control	Off / variable knees 1-10
AutoMode Off/On	Enables / disables the Attack, Hold and Release controls
Threshold Control Range	-60dB to +4dB
Ratio Control Range	Variable 1:1 to ∞:1
Make-Up Gain	-20dB to +20dB
Manual Attack Control	0.1ms to 200ms
Manual Hold Control	0ms to 500ms
Manual Release Control	360dB/sec to 5dB/sec
Limiter Controls	
Threshold Control	-60dB to +4dB
Manual Attack Control	0.1ms to 200ms
Manual Release Control	360dB/sec to 5dB/sec
De-Esser	
Frequency Control	800Hz to 8kHz:
Amount	0% to 100%
SideChain EQ / 3-Band Parametric EQ	
SideChain Monitor	Off/On
TSE Mode	Dark, Warm, None, Light, Bright
Frequency Center Range	25Hz to 20kHz
Q (Bandwidth) Control	.25 to 16
Boost / Cut Range	±12dB

LCD Display

- ◆ The big and clear LCD screen combines just the right combination of size and luminance and provides a full compliment of metering and processing information, as well as navigational hints that allow you to see what you are doing in a hurry, even under less than ideal lighting
- ◆ Digital input and output meters measure internal digital processing levels and show both peak and average levels

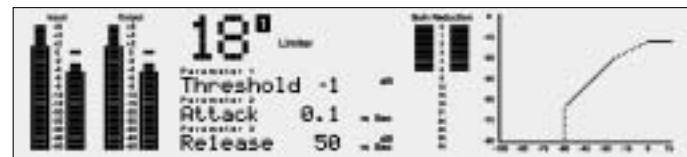

- ◆ High resolution gain reduction metering
- ◆ The screen displays which processing element you are working with along with the amount of gain reduction, as well as input and output levels for the digital processing in both peak and RMS forms, so you can tell exactly what you are doing to the signal with the DDP.
- ◆ The Curve Window provides a realtime graphic representation of the combined effects of all compression-related parameters. When working with the sidechain EQ, or the in-line EQ, the curve window changes to show a graphical representation of the 3 parametric bands in a frequency grid.

24-bit A-D System Performance

Dynamic Range	107 dB typical, unweighted, 22 kHz bandwidth
THD+Noise	0.002% typical at +4 dBu, 1 kHz, input gain at 0 dB
Frequency Response	20 Hz to 20 kHz, +0/-0.5 dB
Interchannel Crosstalk	< -85 dB at 1 kHz, input gain at 0 dB
Common Mode Rejection	>40 dB, typically >55 dB at 1 kHz

24-bit D-A System Performance

Dynamic Range	102 dB typical, unweighted, 22 kHz bandwidth
THD+Noise	0.002% typical at +4 dBu, 1 kHz, output gain at 0 dB
Frequency Response	20 Hz to 20 kHz, +0/-0.5 dB
Interchannel Crosstalk	< -85 dB at 1 kHz, output gain at 0 dB



Input Specs	Impedance	Max. Input Level
XLR & 1/4" TRS Line	>26 kΩ bal / >13 kΩ unbal	> +24dBu
Output Specs	Impedance	Max. Output Level
XLR & 1/4" TRS	120 Ω bal / 60 Ω unbal	>+20dBu into 600Ω

QUANTUM II

Digital Multi-Band Processor

The Quantum II is a digital mastering tool that offers a 4-band



compressor, limiter, expander and gate, 5-band parametric EQ, de-esser, sampling rates up to 96kHz with a true 48-bit digital signal path, and the superior dbx dynamics processing. Insert the Quantum II into the master outputs of any console or workstation and turn out a professional master every time. The 4-way crossover splits the signal into 4-bands, and each band may be individually gated, compressed, and limited. dbx's patented TYPE IV Conversion System with the help of TSE (Tape Saturation Emulation) allows you to retain the original warmth and body of the analog signal while giving it the punch and depth needed in today's digital world of music production and mastering. You can also dither your signal down to 24, 20, or 16 bits, using dbx's custom dither algorithms. For more versatility use full MIDI/SysEx control, and int/ext sync capability. An intuitive user interface puts all the mastering processes you need right at your fingertips. The 5-band parametric EQ offers unprecedented control, with variable Q, adaptable or constant Q, and Lo and High shelving.

Performance

- ◆ Dual Mono or True Stereo Operation with True RMS Power Summing
- ◆ 96 kHz, 24 bit A/D, D/A with a 48 bit internal signal path for increased head room and low level resolution

Dynamics Control

- ◆ Multiband (4 Band) and Stereo or dual mono (Broadband) Gating, Compression and Limiting
- ◆ Control of each of the bands can be done via all band (adjustments are made to all four bands as a group) or individually
- ◆ MS (Middle-Side) Compressor

Parametric SideChain EQ

- ◆ 5-Band Parametric Side Chain EQ with either an adaptive Q or a constant Q response and MS (middle-side) EQ

5-Band Parametric EQ

- ◆ Each of the five EQ bands can be switched On/Off, and can be positioned pre or post dynamics for maximum versatility.
- ◆ All five bands have a sweepable frequency range of 20Hz to 20kHz with ± 12 dB boost/cut in .5 dB steps
- ◆ Bands 1 and 5 are Hi and Low shelves with a 3 to 12 dB/oct slope; bands 2-4 are fully parametric with variable Q (.25 to 16)
- ◆ Choice of constant or adaptive Q response
 - > Constant Q operates similar to an analog graphic EQ where the Q (bell) is constant regardless of cut or boost.
 - > Adaptive Q operates similar to the EQ that is found on a mixing console where the width of the band is constant regardless of the cut or boost.
- ◆ MS (Middle-Side) EQ is available within all stereo linked setups

4-Band Crossover

- ◆ Three crossover points using phase compensated, Butterworth 1st and 3rd order filters, are used to create 4 bands. Tuning them allows you to select which frequencies will be processed with one of the multiband dynamics processors.

Multiband Chain with De-Esser

- ◆ The De-Esser is only available for Stereo Broadband or Dual Mono modes
- > Choice of High Pass (HP) or Band Pass (BP) filter modes
- > Width – sets the Q of the BP Filter
- ◆ Meter Ballistics
- ◆ TYPE IV Conversion System with TSE Tape Saturation Emulation
- ◆ AES/EBU (XLR) or S/PDIF (Coaxial) input/output
- ◆ Sample rate conversion (full up/down)
- ◆ Final output can be dithered to 8, 16, 20, or 24-bit word lengths using SNR2, HPTPDF, or TPDF dither algorithms
- ◆ Dither signal can be routed to both the digital and analog outputs or to the digital output only. This allows the full 24-bit signal to be output to the D-A converters
- ◆ Two different digital noise shape algorithms (S1, S2) are also available
- ◆ Sync input/output uses dbx proprietary clock chips for extremely low jitter sync

Ask the Wizard...

The easiest way to program the QUANTUM II is using the Wizard. In Wizard mode you select the task you need to perform, such as mastering, mixing or tracking, and the Wizard will automatically choose the correct chain type for the task. After selecting a task, you then choose music type, then select the type of EQ, gating, compression, and limiting you are looking for. Once all of the questions have been answered, the Wizard will automatically load a custom setup tailored to your application.

If you are working in a stereo setup, you can optimize output gain by first pushing the EDIT ALL/BAND button and allowing the loudest part of the program material to be recognized. Pressing the button again once the peak has passed, will allow the Wizard to optimize the output level so that the highest peak is set to 0 dBFS.

QUANTUM II

Normalizer/Stereo Adjust

Normalizer is a gain optimizing algorithm located at the end of the signal chain that ensures that the signal being output to tape, disk, etc. is as "hot" as possible without going over 0dBFS

- > ±12 dB level control lets you adjust the final volume sent to the output
- > Ceiling control allows the maximum output level to be set between -3.0 to 0.0 dBFS
- > Stereo adjust – lets you change the width of the stereo mix
- > ±100% balance control adjusts the panning of your signal from left to right
- > M-S controls the width of your stereo image. 0% is untouched, -100% is the narrowest (mono) while +100% is the widest possible stereo image

Ambience Effect

- ◆ Ambience Effect uses a combination of gain and compression to enhance low level information such as reverb tails or acoustic guitar finger picking.
- > Amount 1.0:1 to 5:1 sets the amount of ambience
- > Width 10 to 30 dB controls the portion of the signal that ambience is applied to
- > Thresh -60 to 0 dB – sets the threshold of the ambience processor

Digital I/O

- ◆ TYPE IV Conversion System with TSE Tape Saturation Emulation
- ◆ AES/EBU (XLR) or S/PDIF (Coaxial) input/output
- ◆ Sample rate conversion (full up/down)
- ◆ Final output word length can be dithered to 8, 16, 20, or 24-bit word lengths using SNR2, HPTPDF, or TPDF dither algorithms
- ◆ Dither signal can be routed to both the digital and analog outputs or to the digital output only. This allows the full 24-bit signal to be output to the D-A converters
- ◆ Two different digital noise shape algorithms (S1, S2) are also available
- ◆ Sync input/output uses dbx proprietary clock chips for extremely low jitter sync

Additional Features

- ◆ PC GUI control via the RS232 port
- ◆ Software updateable via Internet and MIDI and RS 232

24-bit A-D/D-A System Performance

Dynamic Range	112 dB typical, unweighted, 22 kHz bandwidth
THD+Noise	0.002% typical at +4 dBu, 1 kHz, input gain at 0 dB
Frequency Response	20 Hz to 20 kHz, +0/-0.5 dB
Interchannel Crosstalk	< -85 dB at 1 kHz, input gain at 0 dB
Common Mode Rejection	>40 dB, typically >55 dB at 1 kHz

Analog Inputs & Outputs	
XLR and 1/4" TRS line	RF filtered, electronically-balanced/unbalanced compatible with +4dBu and -10dBv operation
Input Gain Range	-∞ to +16dB
Output Gain Range	-∞ to +16dB
Gate Controls	
Threshold Range	-75dB to 0dB
Ratio	1:1 to 1:∞
Attack Control	0.1ms to 200ms
Hold Control	0ms to 500ms
Release Control	360dB/sec to 5dB/sec
TCM	Transient Capture Mode Off/On
TCM Time Control	0µs to 3ms in 1000th/sec increments
Compressor Controls	
Band	1 to 4 On/Off
OverEasy Control	Off / variable knees 1-10
AutoMode Off/On	Enables/disables the Attack, Hold and Release controls
Threshold Control Range	-60 to 0 dB
Ratio Control Range	Variable 0.75 to ∞:1
Gain Make-Up	-20dB to +20dB
Manual Attack Control	0.1ms to 200ms
Manual Hold Control	0ms to 500ms
Manual Release Control	360dB/sec to 5dB/sec
Limiter Controls	
Threshold Control	-60dB to +4dB
Manual Attack Control	0.1ms to 200ms
Manual Release Control	360dB/sec to 5dB/sec
De-Esser	
Frequency Control	800Hz to 8kHz:
Amount	0% to 100%
5-Band Parametric EQ	
Frequency Range	20Hz to 20kHz (for all bands)
Boost / Cut Range	±12dB in .5 dB steps (for all bands)
Band 1	Low frequency shelving EQ with a 3 to 12 dB/oct slope
Band 2, 3, 4	Parametric EQ
Q (Bandwidth) Control	.25 to 16 (for bands 2, 3, 4)
Band 5	High frequency shelving EQ with a 3 to 12 dB/oct slope
POS Pre/Post/MS	Sets the position of the EQs in the chain — Pre, Post or MS (Middle-Side) dynamic processors



Input Specs	Impedance	Max. Input Level
XLR & 1/4" TRS Line	>18 kΩ bal / >9 kΩ unbal	> +24dBu
Output Specs	Impedance	Max. Output Level
XLR & 1/4" TRS	120 Ω bal / 60 Ω unbal	>+20dBu into 600Ω

PROVOCAL

Digital Vocal Strip with Digital Output



Think of it as the being the best sound man you've ever had. The ProVocal takes all of the laborious guesswork out of selecting tools for providing great vocal tracking. Offering unmatched versatility at an unparalleled value, the ProVocal is an all-inclusive toolbox perfect for applications including live, studio and karaoke. The ProVocal features a superb microphone preamp coupled with state-of-the-art microphone and mic-pre amp modeling for a wide variety of sonic characteristics. From there you go into classic dbx dynamic processing such as gating, compression, de-esser, and limiter, then on to chorus, flanger, delay and reverb. Other features include a 24-bit S/PDIF output with selectable 44.1 or 48k sample rate and MIDI control.

- ◆ Painlessly helps vocalists create warm and rich vocal tones in the digital domain with crystal clear digital effects, while providing dynamics processing powers that can all be controlled via the smart front panel.
- ◆ Takes models of some the most sought after mics and mic-preamps in the industry, and makes them available at your finger tips.
- ◆ Front panel instrument input
- ◆ Selectable mic/line switch
- ◆ 20dB pad, 48-volt phantom power
- ◆ Output versatility includes XLR and 1/4" analog inputs and outputs and 24-bit S/PDIF digital outputs, making it a truly flexible work horse for any vocal application.

286A Microphone Processor



Forget about the hassle and cost of patching together multiple processors for use on one track. Now you can have all the tools you'll need in one box, with the shortest signal path to help keep your music sounding clean. The 286A's mic preamp and five processors can be used independently or in any combination.

The 286A's sonically pristine mic preamp features wide-ranging input gain control, switchable 48v phantom power and an 80Hz high-pass filter. Use the patented OverEasy Compressor to transparently smooth out uneven acoustic tracks or deliver that classic "in your face" rock vocal. Take out vocal sibilance and high frequency distortion in cymbals with the frequency tunable De-Esser. Fine-tune the Enhancer's HF Detail control to add sparkle and crispness to tracks. LF Detail control adds fullness and depth to vocals and bass instruments while simultaneously cleaning up muddy low midrange frequencies. And, the Expander/Gate's separate threshold and ratio controls allow you to subtly reduce headphone leakage or radically gate noisy guitar amps.

- ◆ A host of metering and status LEDs visually guide you to achieving the right sound.
- ◆ The floating balanced XLR mic input accepts balanced or unbalanced inputs.
- ◆ An additional 1/4" TRS phone jack can accept balanced/ unbalanced line signals to process live electronic instruments or pre-recorded tracks at mixdown.
- ◆ An insert jack between the mic pre and signal processing sections can be used to "loop out" to external processors or to mix the signal out to an external destination.

Subharmonic Synthesizer with Modeled Waveform Synthesis

The disco boom of the 70's was fueled by the throbbing bass beat of dbx Subharmonic Synthesizers in discos around the world. During



the 80's, patented dbx Subharmonic Synthesis was the secret weapon used by mobile DJ's and film and sound professionals to produce an impact unavailable from any other device—unique because the dbx process actually produces a new, Waveform Modeled bass note, exactly an octave below the bass in the original audio. For 2003, the 120A Subharmonic Synthesizer has been specially optimized by dbx engineers for the needs of audio professionals. Two separate bands of bass synthesis provide the best combination of smoothness and control, while the independent Low Frequency Boost circuit gets the most out of high-performance low frequency speaker systems.

- ◆ Patented subharmonic synthesis process builds the synthesized waveform using the waveshape of the original bass material. Unlike other systems, the dbx process produces smooth, musical low frequencies that don't interfere with the mid and high-band, even when maximum synthesis and boost are applied. The result is a low-end punch that you really feel—even at levels that won't destroy equipment or damage hearing.
- ◆ 1/4" (balanced) and RCA inputs, along with main 1/4" outputs which can be full range (including synthesis) or high frequency only, plus separate subwoofer output with its own level control.
- ◆ Individual control for two ranges of subharmonic frequencies
- ◆ Front panel LEDs that show crossover status and synthesis activity
- ◆ Patented circuitry ensures that mid and high frequencies are not affected
- ◆ Built-in crossover with choice of 80Hz or 120Hz crossover point
- ◆ Enhance bass audio material for use in a variety of applications including:
 - Nightclub and dance mixing • DJ mixing
 - Theater and Film sound • Music Recording
 - Live Performance • Broadcasting • Aerobics

223/234 • 223XL/234XL

Stereo 2-Way/Mono 3-Way and 2/3/4-Way Crossovers



Extremely well built and great looking, the 223 and 234 feature switches on the rear panel for stereo 2-way or mono 3-way (mono 4-way on the 234) operation, LF mono sum (for a subwoofer feed) and a

range of individual channel crossover frequencies. The XLR versions (223XL and 234XL) feature TRS differentially-balanced XLR inputs and outputs in place of the standard 1/4". Perfect for permanent installations and touring PA systems.

- ◆ Mode switch for stereo 2-way or mono 3-way operation (223)
- ◆ Mode switches for mono 4-way or stereo 2-way/3-way operation (234)
- ◆ x10 range switch on both channels
- ◆ LEDs indicate when "x10" switches on the back panel are activated and whether the unit is in stereo or mono mode.
- ◆ Linkwitz-Riley 24dB per octave filters
- ◆ Recessed 40Hz low cut (HPF) switches on each channel are available to remove unwanted low frequencies.
- ◆ Both the low and high outputs on each channel have a gain control ranging from infinity to +6dB to allow muting of individual outputs and for level matching. Phase reverse switch on all outputs
- ◆ Controls exude great precision, and the feel is a solid "click".
- ◆ Internal 120/240v power supply eliminates the need for annoying wall-warts.
- ◆ TRS differentially balanced 1/4" inputs and outputs are bolted to the chassis, so even if someone stomps on a plugged in cable, it won't tear up the circuit board inside.

12 SERIES EQUALIZERS

Dual Channel 15-Band and 31-Band Graphic Equalizers

The 1215 and 1231 equalizers are designed to meet the needs of the most demanding sound reinforcement environments, while offering simple and straightforward controls. Both units offer dual channel operation. The 1215 provides 15 2/3 octave bands with ISO frequency centers, while the 1231 provides 31 1/3 octave bands with ISO frequency centers. Both feature 45 mm faders, selectable $\pm 6\text{dB}$ or $\pm 15\text{dB}$ boost/cut ranges, $\pm 12\text{ dB}$ input gain range, and switchable 40Hz/18 dB per octave low-cut filters. Precision engineered to provide years of maintenance-free operation in any application, they utilize only the best possible components. RF Filtered, electronically-balanced XLR, barrier strip, and 1/4" TRS inputs and outputs provide ease of installation, while magnetically isolated transformers and chassis/signal ground lift capabilities ensure quiet performance.

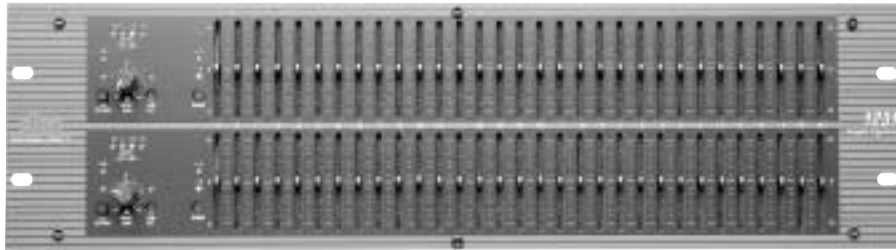
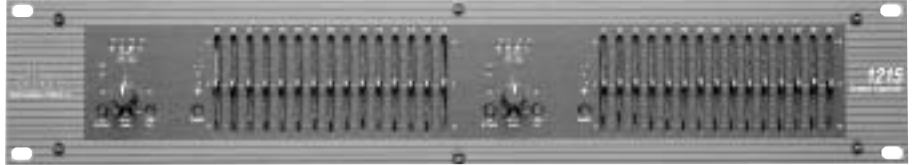

RF Filtered, electronically-balanced XLR, barrier strip, and 1/4" TRS inputs and outputs provide ease of installation, while magnetically isolated transformers and chassis/signal ground lift capabilities ensure quiet performance.

The Last Word in Affordable, High Quality EQs

With the dbx 12 Series the goal was simple; build the best bang-for-the-buck, no nonsense equalizers on the market. Price/performance champions, the 1215 and 1231 are designed for down-to-earth sound shapers who don't need a feature-laden 20 Series EQ, but who absolutely demands a pristine signal path and consistent performance in an equalizer.

System Performance

Common Mode Rejection	>40dB, typically >55dB at 1kHz	
Frequency Response	<10Hz to >50kHz, +0.5/-3dB	
Signal to Noise $\pm 15\text{dB}$ Range	90dB	
Signal to Noise $\pm 6\text{dB}$ Range	97dB	
THD+ Noise	<0.04%, 0.02% typical at +4dBu, 1kHz	
Dynamic Range $\pm 15\text{dB}$ Range	109dB	
Dynamic Range $\pm 6\text{dB}$ Range	115dB	
Interchannel Crosstalk	<-80dB, 20Hz to 20kHz	

Input Specs	Impedance	Max. Input Level
XLR, 1/4" TRS and Barrier Strip	>40k Ω balanced >20k Ω unbalanced	>+21dBu (2k Ω) balanced or unbalanced
Output Specs	Impedance	Max. Output Level
XLR, 1/4" TRS and Barrier Strip	200k Ω balanced 100k Ω unbalanced	> +21dBu (2k Ω) balanced or unbalanced

Inputs & Outputs

Rear Panel	RF Filtered, Electronically-balanced / unbalanced XLR, 1/4" TRS and Barrier Strip
Input Gain Range Control	-12dB to +12dB

Function Switches

EQ Bypass	Hardwire bypasses of the graphic EQ section with 2-second power-up delay
Low Cut (recessed)	Activates the 40Hz 18dB/octave Bessel high-pass filter
Range (recessed)	Selects either $\pm 6\text{dB}$ or $\pm 15\text{dB}$ slider boost/cut range

Metering

Output Level	4-Segment LED @ -10, 0, +10 and +18dBu
Clip	Red LED

Power Supply

Operating Voltage:	100V AC 50/60Hz; 120V AC 60Hz
--------------------	-------------------------------

- ◆ Selectable $\pm 6\text{dB}$ or $\pm 15\text{dB}$ boost/cut range for precise gain adjustments
- ◆ Electronically balanced/unbalanced inputs
- ◆ Servo balanced/unbalanced outputs
- ◆ RF filtered inputs and outputs
- ◆ XLR, Barrier Strip, and 1/4" TRS connectors
- ◆ $\pm 12\text{dB}$ input gain range
- ◆ 18dB/octave 40Hz Bessel low-cut filter
- ◆ Chassis/signal ground lift capability
- ◆ Internal power supply transformer
- ◆ Power-off hardwire relay bypass with 2-second power-up delay

20 SERIES EQUALIZERS

Graphic EQs with Type III Noise Reduction

There are three EQs available in the 20 Series; the 2031 single channel 31 band 1/3 oct, the 2215 dual channel 15 band 2/3 oct, and the 2231 dual channel 31 band 1/3 oct. Each of these offers the same precision engineering, top shelf components, I/O and features plus, they add two powerful tools that let you use your system with confidence — dbx's proprietary Type III Noise Reduction which is capable of increasing signal-to-noise ratios by up to 20dB, as well as the patented PeakPlus limiter which provides fail-safe system protection for your sound system. A four stage LED ladder gives you a great visual indication as to what the limiter and signal levels are doing. Offering great value and an unequalled feature set, dbx's 20 Series equalizers have become crucial links in the sound systems of countless professionals all over the world.

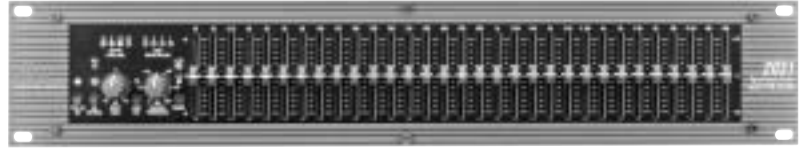

2031 Single Channel 31 band 1/3 octave

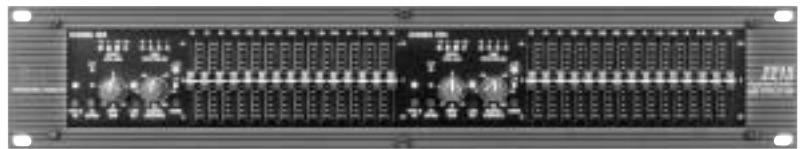

2215 Dual Channel 15 band 2/3 octave



2231 Dual Channel 31 band 1/3 octave

SAME FEATURES AS THE 12 SERIES PLUS—

Type III Noise Reduction

- ◆ Each channel features individually switchable, transparent noise reduction circuitry, capable of restoring up to 20dB S/N ratio
- ◆ A virtually instantaneous encoding and decoding algorithm allows radical EQing without substantially affecting noise performance

PeakPlus Limiter

- ◆ The PeakPlus Limiter circuitry available on each channel utilizes a variable 0dBu (off) to +24dBu threshold control to provide fail safe system protection

Metering

- ◆ Four segment LED bargraph provides metering for BOTH Gain Reduction and Output Level
- ◆ Status LEDs offer visual feedback for all settings on the front panel.

System Performance

Common Mode Rejection	>40dB, typically >55dB at 1kHz	
Frequency Response	<10Hz to >50kHz, +0.5/-3dB	
Signal to Noise ±15dB Range	>90dB (NR out), >100dB (NR in)	
Signal to Noise ±6dB Range	>94dB (NR out), >100dB (NR in)	
THD+ Noise	<0.04%, 0.02% typical at +4dBu, 1kHz	
Dynamic Range ±15dB Range	108dB (NR out), >118dB (NR in)	
Dynamic Range ±6dB Range	112dB (NR out), >118dB (NR in)	
Interchannel Crosstalk	<-80dB, 20Hz to 20kHz	

Input Specs	Impedance	Max. Input Level
XLR, 1/4" TRS and Barrier Strip	>40k Ω balanced >20k Ω unbalanced	>+21dBu (2kΩ) balanced or unbalanced
Output Specs	Impedance	Max. Output Level
XLR, 1/4" TRS and Barrier Strip	200k Ω balanced 100k Ω unbalanced	> +21dBu (2kΩ) balanced or unbalanced

Inputs and Outputs

Rear Panel	RF Filtered, Electronically-balanced / unbalanced XLR, 1/4" TRS and Barrier Strip
Input Gain Range	-12dB to +12dB

Function Switches

EQ Bypass	Hardwire bypasses of the graphic EQ section with 2-second power-up delay
Type IV NR	Activates dbx Type III ^a Noise Reduction
Low Cut	Activates the 40Hz 18dB/octave Bessel high-pass filter
Range	Selects either ±6dB or ±15dB slider boost/cut range

PeakPlus Limiter

Threshold Control	0dBu - +24dBu (OFF)
-------------------	---------------------

Metering

Output Level	4-Segment LED @ -10, 0, +10 and +18dBu
Clip	Red LED
Gain Reduction	4-Segment LED display for PeakPlus Limiter
Operating Voltage:	100v AC 50/60Hz; 120v AC 60Hz

EVENTIDE

ECLIPSE

Harmonizer Effects Processor



The Eclipse unit provides the power, performance and signature Eventide audio effects in a single rack space unit, the company's first in that configuration. The folks at Eventide were not looking to build a "junior" Harmonizer product. In fact, even though it's just half the size of the legendary H3000 series Harmonizers, Eclipse has five times the processing power, and twice as many features. Eclipse features a dual-engine architecture, that can be configured in series, parallel, stereo or dual mono. Setup and operation is intuitive, with an enhanced user interface and a powerful search facility for rapid program/preset selection by category or application. The audio performance of the Eventide Eclipse Harmonizer unit surpasses just about anything in its class, with 24-bit digital conversion, 96kHz sampling and a signal to noise ratio exceeding 104dB. Digital S/PDIF and AES/EBU I/O, analog balanced and unbalanced I/O and ADAT lightpipe are all supported. Eclipse's heavy-gauge, all metal faceplate, solid, positive-action controls and sharp, bright display further demonstrates the "fully professional" claim for the product. Eventide's famous "knob" and full numeric keypad are included, as well as customizable "hot keys" for maximum flexibility and ease of operation. Eclipse answers the call for many musicians and working professionals seeking Eventide-quality pitch change, reverb and special effects programs in a compact box that is affordable and uncompromising.

FEATURES

- ◆ Up to five times the processing power, yet half the size of the legendary H3000 series Ultra-Harmonizer brand effects processor.
- ◆ Dual-engine architecture (two configurable effects blocks), configurable in series, parallel, stereo or dual mono.
- ◆ 24-bit resolution for superb fidelity at up to 96kHz sampling and a signal to noise ratio better than 104dB.
- ◆ The famous Eventide "knob", full numeric keypad and customizable "hot keys" for frequently used parameters provide maximum flexibility and ease of use.
- ◆ A global tempo feature synchronizes LFOs, delay times, and other time-sensitive parameters to the music being processed.
- ◆ A full complement of LFOs, envelope followers, and ADSRs can be patched to any parameter.

500 Programs

- ◆ 400 factory and 100 user programs with a full complement of Eventide's signature pitch change, reverb, and special effects presets are provided all with, all with uncompromising quality.
- ◆ An additional 500 programs can be stored on a compact flash memory card.
- ◆ Besides viewing programs by program number, they are flagged so they can be sorted by application (Guitar, Vocals) and effect type (Pitch, Reverb, Delay).

Algorithms

- ◆ Presets are made up of 1 or 2 algorithms.
- ◆ Each algorithm is a block of signal processing elements, such as mixers, shifters, compressors, etc, that can be a powerful and sometimes complex effect in itself.

I/O Connectors

- ◆ Dual (left/right) balanced XLR, unbalanced 1/4" combi inputs
- ◆ Dual (left/right) balanced XLR and unbalanced 1/4" outputs
- ◆ AES/EBU (XLR) and coaxial S/PDIF digital I/O plus an optical interface that can be switched between ADAT and S/PDIF.
- ◆ Word Clock I/O (BNC)
- ◆ The MIDI Out and Thru connectors plus a 7-pin MIDI In port for use with pedal boards or standard 5-pin devices.
- ◆ A 9 pin RS232 serial connector allows you to transfer information to and from your computer.
- ◆ Two Stereo 1/4" multi-function foot pedal / foot switches inputs can be used for adjusting parameters

EVENTIDE/MANIFOLD LABS

PLUGZILLA



Standalone Plug-in Player

Plugzilla is a unique two rack space effects processor capable of running nearly any Windows-based VST plug-in. Since its preview at the Audio Engineering Society's 113th annual

convention, Plugzilla's launch has

been widely anticipated throughout the industry. Plugzilla employs two independent fully routable machines capable of running 32 channels of reverb, and the ability to simultaneously power as many as eight plug-ins. Plugzilla's brings a new level of versatility, power, and portability to the rapidly expanding world of plug-ins. Plugzilla adds a new dimension to front of house mixing, live stage rigs, recording studios and mastering rooms. It can store thousands of plug-ins and presets in its internal Flash memory and features USB and Compact Flash connections for efficient plug-in transfers. In addition, 32 midi channels plus four footswitch inputs and two sets of eight "hot knobs" and "hot switches" that can easily be assigned and routed to plug-ins add incredible flexibility to the product. Plugzilla is designed by Manfold Labs, a new company comprised of some of the pro audio industry's leading effect processor designers.

FEATURES

World's First Standalone Plug-in Player

- ◆ Starting with Steinberg's VST 2.0 standard, and adding a quick, intuitive user interface, stellar audio performance, and wrapping it in a sexy, quiet 2RU package, Plugzilla will forever change your idea of VST plug-ins, rack mounted effects processors, and synthesizers.
- ◆ Fully compliant with Steinberg's VST 2.0 specification
- ◆ Runs virtually any Windows-based VST plug-in* - including VSTi instruments.
- ◆ Two independent, fully routable machines
- ◆ Runs up to eight plug-ins simultaneously
- ◆ Store thousands of plug-ins and presets in internal Flash memory
- ◆ High performance processing - capable of running 16 channels of reverb.
- ◆ Eight snapshot memories allow quick comparisons and creative flow

(*depends mostly on copy protection scheme)

Bring your VST plug-ins to the live gig, recording studio and mastering session. Add DSP to your computer-based Digital Workstation.

Quick, Simple and Easy-to-Use Interface

- ◆ Two sets of eight "Hot Knobs" and "Hot Switches" can easily be assigned and routed to plug-ins providing incredible flexibility for accessing realtime control and automation functions.
- ◆ Dual bright fluorescent information displays
- ◆ Compact FLASH slot and a USB port are available for additional plug-in storage.
- ◆ More than 200 plug-ins are loaded when shipped.

Inputs and Outputs

- ◆ Dual stereo/four channel 96kHz/24 bit balanced XLR analog inputs and outputs
- ◆ Input to output latency at 48kHz sample rate is less than 4 msec.
- ◆ Coaxial S/PDIF Digital inputs and outputs
- ◆ Two MIDI In and Out ports provide 32 MIDI channels
- ◆ Two footswitch inputs with full routing and assignment to plug-ins.
- ◆ Universal power supply (90 - 240VAC / 50-60Hz)

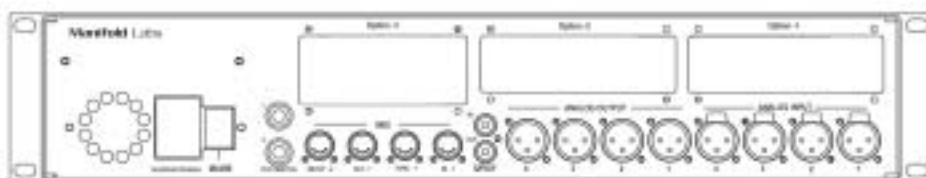

FOCUSRITE

PLATINUM OCTOPRE

8-Channel Mic Preamp



With eight pristine channels, class A Focusrite processing, eight compressor/limiters and almost all the interface options known to man, the OctoPre makes high quality, multi-channel recording easy. The perfect partner for any digital audio workstation, it is equally suited as an instant location recording solution, or as an additional set of mic preamps for any analog, digital or hard disk recorders. Each channel features a revolutionary compressor/limiter circuit, providing a warm-sounding compressor, which morphs into a brick wall limiter to avoid those critical overs, ensuring total control over all eight channels. The first two 'Super channels' also feature phase reverse, as well as TRS inputs on the front for quick and easy, DI-free plug-in. Finally, the high quality digital converter options cover almost every interfacing eventuality. Up to sixteen digital outputs can run simultaneously with any mix of analog outputs, and all the settings are adjustable, directly from the front. With this entire package fitting into a single 1U chassis, OctoPre sets the standard for multi-channel recording solutions.

FEATURES

Dynamics Control

- ◆ OctoPre features eight independent compressor/limiters, whose revolutionary circuit design allows dynamics to be handled via a single control. Starting with a brick-wall limiter the rotary control then allows you to add increasing amounts of compression.
- ◆ Two independent side-chain control circuits are used for each channel of dynamics, one for limiting and one for compression. The limiter and compressor side-chains each generate two separate control signals, one fast and one slow, that are then fed to the gain change elements in the audio path.
- ◆ The gain control elements consist of a pair of custom Optos, which follow a crossover network that splits the audio into two bands, "high" and "low". The fast side-chain drives the high frequency opto, while the slow side-chain drives the low frequency opto. This ensures less distortion when the limiter is reacting to very fast transients. By splitting the response, only the high frequency section of the waveform is drastically affected, reducing distortion, and therefore non-related harmonics, providing a far more musical effect.
- ◆ In addition, both the side-chains operate as feedback systems. Thus, the amount of compression and limiting is calculated using the level after the split opto stage. The advantage of this feedback system is that the limiter senses the level after compression has been applied and therefore the limiter only works when it absolutely has to.
- ◆ The dynamics control also introduces an additional make-up gain, balancing the level change caused by compression. This auto make-up gain ensures the output level to the A/D remains constant while further compression is applied. Consequently, any input levels already set will not require any further adjustment during dynamics set-up. Only one dial, but all the control, providing the quickest route to a warm, controlled, yet entirely musical signal.

Class A Pre Amp

- ◆ Mic preamps are the same as those in the award-winning, VoiceMaster PRO. The custom preamp ensures low noise and distortion, delivering clarity and warmth without unwanted artifacts.
- ◆ Also found in this section are phantom power, a Line level switch and a High Pass filter, enabling OctoPre to handle a multitude of audio sources simultaneously, with style and grace.

Super Channels

- ◆ The first two channels also feature high quality instrument inputs and phase reverse, both available direct from the front, avoiding the need for a separate two channel DI box.
- ◆ Both channels allow all three sources to be patched simultaneously, with inputs selectable directly from the front panel allowing the unit to be permanently racked and patched to your own specifications.

Outputs

- ◆ Eight line level balanced (+4 dBu) analog inputs and outputs are provided as standard via 25-pin connectors. These connectors are routed to 8 XLRs via a breakout cable (sold separately). In addition to the analog outputs, there are two optional digital outputs available:
- ◆ Two high-quality, 24-bit A/D converters handle rates up to 96kHz, but can dither down to 20 or 16 bit. Frequency settings and bit rates can be altered with an ADC lock LED to show when word clock is synchronized. An external wordclock input is also provided (BNC).
- ADAT outputs only - 8 channels of ADAT lightpipe
- 8 AES/EBU or S/PDIF outputs plus 8 channels of ADAT all on one board. The AES/EBU or S/PDIF outputs can run simultaneously with ADAT outputs, giving you 16 channels of digital output.

PLATINUM MixMaster DIGITAL

Stereo Dynamics, EQ and Image Processor

The MixMaster is an analog stereo audio processor designed primarily for project studio mastering.

However, with so many useful features

in one box, anyone involved in the business of making music will quickly find it indispensable at other stages of the recording process too. This piece of outboard genius refines the final balance and dynamic energy of the mix, introducing stereo enhancement while restoring essential elements which may have become overwhelmed in the mixing process. Simple yet effective processing sections cover every aspect of the mix, giving you the quickest route to that seemingly 'out of reach' sound that makes a hit record. Within minutes you can give your mix punch, width and sheen with the signature transparency and sonic integrity that made Focusrite famous.

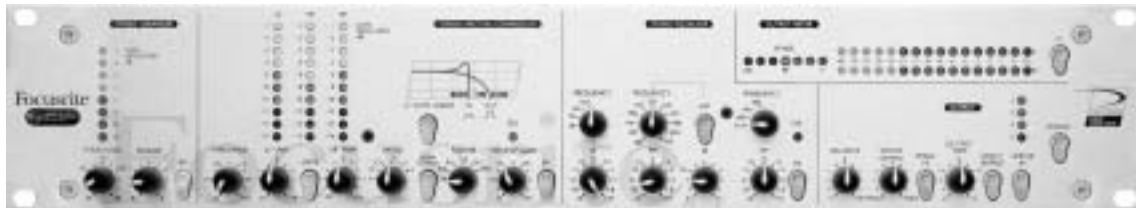

FEATURES

High Quality A/D Converter

- ◆ A 16/24-bit and 128x over-sampled digital interface enhancement with a sampling rate of up to 96kHz is built-in.

Stereo Expander

- ◆ Essentially a soft noise gate, the stereo expander decreases unwanted background noise without sounding harsh or brutal. With only two controls (threshold and release) and an LED monitoring display, controlling the noise floor becomes a breeze.

Stereo Spectral Compressor

- ◆ The Stereo Spectral Compressor is a multi-band compressor with three bands of compression, Low, Mid and High, each being visually displayed – vital when you need to smooth out different frequency bands and have true control over the mix.
- ◆ When using a single band compressor, a loud kick drum can, for example, cause the compressor to pump on every kick. In dance music this effect might be desirable and consequently you have the option to lock the compressor across the bands. The MixMaster also allows you to individually compress each of these three bands, so taming the kick alone is as easy as turning down the LF trim. Taming an overly loud vocal or hi-hat is just as easy; Using the MID band for vocals and the HF band for hi-hat and snare, you have complete control over these specific areas.
- ◆ The MixMaster simplifies this process to 5 knobs, and 2 buttons, all of which are easy to understand, and allow you not only to hear but also see what effect they are having on your mix.
- ◆ A track put through this section will, when adjusted, sound tighter, bigger and smoother. Finally, a device that delivers that elusive finished, professional sound. The process is not difficult to employ. Use your ears and you will soon be grinning from one to the other as your mix comes to life! Also included in this section is the "LF slope adjust" switch. Switching the circuit in gives a fuller bass sound, an instant enhancement for dance mixes at the flick of a switch.

Stereo EQ

- ◆ The Stereo EQ on the MixMaster is tri-band, with stepped frequency shelving high (HF) and low (LF) bands, and a parametric mid band. A serious Focusrite EQ with the ability to add musicality and subtlety to your mix.
- ◆ The "tilt" feature allows gentle emphasis or de-emphasis at either end of the audio spectrum and is a vital mastering function. The MixMaster EQ is a very powerful tool that can gently enhance the tonal quality of the mix, according to the user's objective.

Analog Spatial Enhancer

- ◆ For widening your stereo image. A slight adjustment of the image controller allows you to create an ambient, spacious mix that extends beyond the normal stereo extremities, breathing new life into your projects. A tweak in the opposite direction produces a narrowed, focussed image.
- ◆ Many width enhancers can cause phase coherence problems for centrally-panned mix elements, but the MixMaster's additional direct inputs allow critical central elements (like lead vocals or a kick drum) to be added to the mix after stereo enhancement. This allows you to enjoy the benefit of wide, airy mixes, but retain critical tight focus on, say, the lead vocal.

Output Control

- ◆ The output section gives fine control of stereo balance and trim is available before the A/D converter or analog outputs. For output protection, switch in the stereo frequency adaptive limiter, with its own LED meter, to stop those critical digital 'overs'.



Rear view of the Platinum MixMaster Digital

FOCUSRITE

PLATINUM PENTA

PROCESSORS

264

Stereo Analog Preset Compressor

A stereo compressor with 16 preset compression settings set among a host of Class A analog circuitry, the Penta offers that sought-after professional sound at the touch of a button. The presets, configured by a prestigious group of music industry professionals, can be freely adjusted, enabling users to tailor compression to their individual needs.

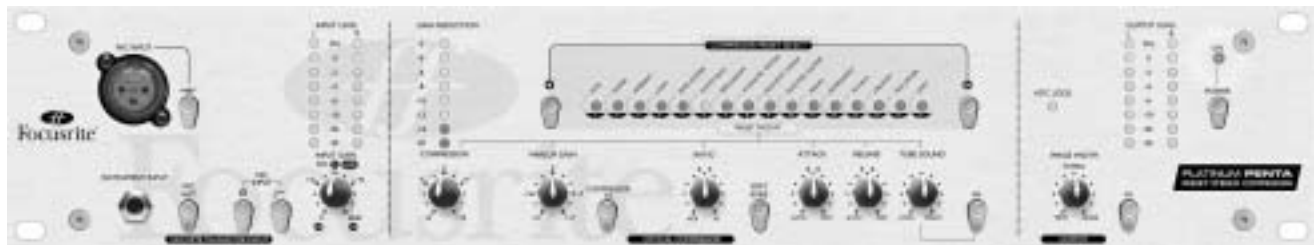

Packed with analog processing power including a Focusrite Class A mic pre, TubeTran technology and spacial enhancer, the Penta offers a huge number of recording benefits within a matter of seconds while still exhibiting the Focusrite signature sound. Use as a front end when tracking quality signals, as a mix-down processor, or as a final mastering processor. Every dynamics processor you'll ever need, squeezed into one 2U rack-mountable unit, the Penta will be the best investment you ever made.

Preset Stereo Compressor

The Penta offers you instant compression settings, as formulated by the Focusrite design team. Immediately available are 16 presets specifically designed to give you perfect compression at the touch of a button. But to make sure they don't limit your potential, these presets are entirely editable, giving you a quick, yet effective route to perfect compression.

Kick	Creates a full and deep effect. Use the attack to control the amount of punch desired for your track.
Snare	Set up for perfect control of stick (attack) and ringing overtones (release).
Ambient	Use with live drums or instruments and lift out natural room effects or get the best from digital reverbs.
Loop	Tight and fast compression, especially suited to sampled loops and electronic sounds.
Bass Guitar	Plug straight into the front panel and call up deep and rounded sounds or punchy slap.
Synth	Bass Fat sounding especially when used with the warmth control to give a true vintage valve sound.
Percussion	Acoustic or sampled drums.
Acoustic picked	High threshold and ratio give a controlled yet highly dynamic response.
Acoustic strum	Clean and crisp with a touch of warmth. Gives a clear but warm and naturally compressed effect.
Electric Guitar	Clean or distorted, plugged straight in or mic'd up, the opto compressor is perfect for guitar.
Piano	Achieve clarity and low distortion. Wide dynamic range and long sustaining mid range make the piano the most difficult of instruments to compress well, ...until now.
Keyboards	Great for pads, this compressed and warm setting is especially suited for use with the image control to maximize stereo width.
Vocals	Smooth, controlled and clean for male or female vocal recording.
Crunch	An essential setting for big beat or drum loops.
Mix (pump)	The classic loud and full on mastering compression setting.
Vocals (limit)	High threshold and plenty of warmth give a very dynamic upfront vocal performance.



For Any Inquiries Regarding Your Order, Call Our Customer Service:
(800) 221-5743 • (212) 239-7765 • FAX: (800) 947-2215 • (212) 239-7549

PLATINUM COMPOUNDER

Discrete Transistor Mic Pre

- ◆ The Penta offers the same Platinum mic pre featured in the award-winning VoiceMaster, ToneFactory, and the industry transforming Control/24 from Focusrite. The Penta ensures professional performance within the audible frequency range and beyond, producing cleaner recordings and delivering clarity without coloration.

Direct Input

- ◆ The Penta features a direct input on the front panel for quick and easy plug-in. Use the Penta as a front end for getting all your instruments down to track in seconds.
- ◆ Use the Penta as a mono compressor when recording a vocal or instrument, AND as a stereo compressor when mixing down. (When necessary, the Penta may also be used as a stereo compressor when recording, if it is inserted across two channels of a mixing console, or when compressing e.g. a stereo keyboard signal.)

TubeTran Technology

- ◆ Focusrite's Exclusive TubeTranTechnology gives you controllable tube style warmth. This unique effect is achieved using a dedicated discrete mosfet circuit, specifically designed to create this indistinguishable audio illusion. Instead of limiting your studio to one sound, now you can choose – less tube, more tube, no tube, you decide.

Analog Spatial Enhancer

- ◆ The Penta features an image width enhancer for altering the apparent image width of a stereo source. With the Image Width control you can widen the stereo image of your mix to create an ambient, spacious mix that extends beyond the normal stereo extremities, breathing new life into your projects. A tweak in the other direction produces a narrow, focused image.

Output

- ◆ Featured in the final section is a comprehensive visual meter to help you ensure optimum levels at all times. The Penta also uses the same optional high quality A/D converter as the VoiceMaster and Trak Master, making digital interfacing a breeze.

The Compounder is a high performance stereo dynamics processor designed for the quality conscious professional and project studio owner. This highly featured unit is an essential tool for any style of music. The combination of high quality compression with the powerful Bass Expander, make this unit a must have for any dance music engineer or musician.

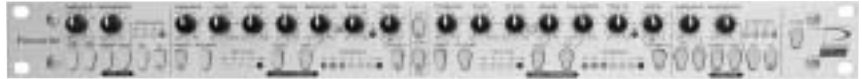

Gate/Expander, Compressor, Limiter

- ◆ The unique opto circuit featured in the Gate/Expander section ensures quiet operation with no pops or clicks. You have accurate control over gating and the expander switch ensures professional noise reduction on difficult audio tracks such as vocals.
- ◆ Compounder's compressor features Class A amplification and a VCA circuit design derived from the legendary Red 3, resulting in superb sound and very low distortion.
- ◆ Soft and Hard Knee compression curves and a wide ratio control that takes you beyond infinity, means you have substantial control over compression.
- ◆ With the unique Bass Expander section you can make kick drums and bass riffs far more powerful and effective. The expander circuit generates extra bass harmonics to fatten up any low frequency signal.
- ◆ A matched pair of high quality Optos offers improved performance over VCA limiter designs which tend to add high levels of distortion, even when they are not limiting. The Limiter features a Class A low distortion design and accurate threshold control to ensure quality precision limiting. The limiter enables you to prevent overload when recording to an A/D.

True Stereo Linking

The link feature enables the Compounder to act as a true stereo compressor, enabling complete stereo control of every parameter. When switched to stereo the left channel becomes the master section and controls both left and right compressor and limiter sections simultaneously. You can also choose to operate the unit as a dual mono device allowing you to process two separate channels independently.

COMPOUNDER SPECS:

Compressor

Threshold	
Range:	-24dB to 12dB
Ratio:	1.3:1 through infinity to over-compression
Slope:	select between hard and soft knee.
Attack and Release:	Variable or auto (program dependent) Attack: 100µS to 100mS Release 100mS to 4S

Limiter

Threshold Range:	12dBu to 26dBu
Ratio:	infinity
Attack:	Fast

Gate

Threshold Range:	-40dB to +10dB
Gate Range:	-20dB or -80dB (full)
Attack:	switched fast or slow
Release/ Hold:	variable or fixed 100mS to 4S

Expander Ratio:	2:1
-----------------	-----

FOCUSRITE

PLATINUM VOICEMASTER PRO

Dedicated Engineering for Vocals



An end to the search for that elusive perfect vocal—VoiceMaster PRO represents a new generation of Channel strip design. The award-winning Class A Pre-amp is capable of capturing every nuance from any source, while latency-free monitoring ensures direct and delay-free mix control. Tools such as the Voice optimized EQ, 'Vintage Harmonics' and 'Tube Sound' allow you to get creative with a touch of class, putting your own stamp on every recording. Combined with the 24-bit, 96kHz A/D option, the VoiceMaster PRO is the perfect interface between your mic and DAW or other recording media.

FEATURES

Discrete Transistor Mic Pre

Audiophile-quality, Class A transistor mic pre features Rupert Neve's wide bandwidth design to ensure low noise and distortion, delivering clarity without coloration. Provides the signature transparency that Focusrite is famous for. Also found in this section are Phantom Power, Phase reverse and a variable High Pass filter for controlling rumble, proximity effect and pop reduction, enabling VoiceMaster PRO to handle any audio source with style and grace.

Direct Input

Also included on the front panel are mic and instrument inputs, allowing quick and easy connection without the need for a separate DI box. Although optimized for vocal use, VoiceMaster PRO can equally turn its hand to any instrument with outstanding results.

Tube Sound

Equipped with cutting-edge valve emulation technology, the Tube Sound section provides all the warmth and control, without the unreliability/unrepeatability that valves often entail. Tube Sound circuit produces 2nd, 3rd and 5th harmonics relative to the source audio, the frequencies being controlled by the Tone control knob ('Mellow' to 'Bright'). The level of effect applied is adjusted via the 'DRIVE' control ('Cool' to 'Warm'). This section ensures you get exactly the sound you're looking for.

Optical Expander

The optical expander is the perfect tool for removing ambient noise and headphone bleed, while avoiding signal pumping. The release control is variable, allowing for a very accurate set-up. Can also be tailored for a more aggressive approach on less sensitive signals such as electric guitar or drums.

Optical Compressor

Designed specifically for voice with easy-to-set-up dynamic control of performance changes. Servo-controlled optical attenuators give more punch and fat sounding compression, especially when driven hard. Offers soft (vocals) or hard (drums or electric guitars) compression. The additional enhancer (treble) enables you to add brightening harmonics to a vocal which lacks character. A 'post EQ' switch enables frequency-conscious compression.

Voice Optimized EQ

Designed to give immediate results to live or pre-recorded vocals. Controls include:

- Breath -shelving EQ, switchable from 16K to 10K adds air to both female and male vocals
- Mid -A bell-shaped curve at 1K3 to give vocals bite in a busy mix
- Absence -A notch filter with a narrow Q centered at 3K9 to remove harshness
- Warmth -bell curve, tuneable from 120Hz to 600Hz, adding depth and volume

Vintage Harmonics

Vintage Harmonics ensure your vocal sits prominently in the mix, while adding character to an otherwise sterile digital environment. Emulates a classic tape-based vocal enhancement technique employed during the 1970's.

Optical De-esser

The same optical de-esser as the ISA 430, the circuit allows you to transparently remove excessive sibilance from your vocal. A 'Listen' switch allows you to isolate and monitor the excess sibilance which is triggering the De-esser, rather than trying to pick out the effect within a complex full-bandwidth signal.

Latency-Free Monitoring

You can monitor your source signal within the mix directly from the unit, avoiding having to monitor via your DAW or digital desk, both of which may be prone to latency issues. A headphone mix can be created for either the artist or the engineer, with immediate and tactile control over levels, as well as the opportunity to feed in and control an external effect (e.g. reverb) for the source signal.

Output Features and Controls

A custom peak-reading meter, when combined with the fader control and an overload LED, provide superb visual indication and instant control of output levels. A 'Process Bypass' switch provides instant A/B comparisons.

FOCUSRITE

PLATINUM TRAK MASTER



Never before has there been a more affordable tracking device, which still manages to encompass the design philosophy and integrity that have ensured that Focusrite be held in such high esteem over so many years. The Trak Master boasts the same high quality mic pre and compression circuits as the Platinum Penta, with performance specifications never before seen in this price range, setting a new standard for project studio signal processing. A high quality mic pre, intuitive compression, a 3-band flexible EQ, and 'tube sound' control come together to ensure you have all you require to get a quality signal tracked. You even have the option to fit a Focusrite A/D card taking you directly from the Trak Master into your digital workstation, while retaining the Focusrite signature sound of 'clarity without coloration', as you flow from analog to digital.

FEATURES

Discrete Pre Amp

Audiophile quality Class A transistor mic pre design features the wide bandwidth design philosophy featured in original Focusrites from years past. This design ensures low noise and distortion, delivering clarity without coloration, giving the signature transparency for which Focusrite have become famous. This section also features phantom power and a high pass filter, enabling it to handle any microphone with grace, while removing proximity effect and wind noise.

Direct Inputs

Features both a mic input and an instrument input on the front panel for quick and easy plug-in, without the use of a separate DI box. Use the Trak Master as a front end to your system and enjoy quality vocal and instrument recordings, tracked in seconds.

Tube Sound

Focusrite patented 'Tube Sound' technology gives you controllable tube style warmth. This unique effect is achieved using a custom, dedicated discrete MOSFET circuit, specifically designed to emulate tube harmonics. Instead of limiting your studio to one sound, now you can choose - more tube, less tube, no tube.

Output Level

Comprehensive output metering and control ensures that levels accurately matches the following processor's requirements.

Optical Compressor

Comprised of servo-controlled optical attenuators that deliver better results than equivalent VCA designs, the optical compressor gives more punch and fatter sounding compression. A single control for more or less compression is complemented by a 6 LED meter for clear visual indication of gain reduction.

'Tight' and 'Punch' switches allow easy selection of Compression settings, and extra control over the dynamic range. Compression can be applied either Pre or Post EQ allowing more control over extreme dynamic effects and EQ.

Threshold: -22dB (MORE) to +12dB (LESS)

Ratio (TIGHT switch out): 3:1, soft knee

Ratio (TIGHT switch in): 6:1, hard knee

Attack (PUNCH switch out): 3ms

Attack (PUNCH switch in): 45ms

Release: 100ms (FAST) to program-dependent slow (SLOW)

Makeup gain: +20 dB

3-Band EQ

Intuitive, versatile and extremely easy to use, the EQ section boasts two modes of operation to guide you to the best sounding EQ curves. The bass control features specifically selected frequency ranges and filter configurations, stretching down to 25Hz with earth shattering results. Equally as versatile, the treble turnover frequency can be switched between 10K and 3.3K enabling you to add shine to any sound. At the flick of a switch the EQ can be optimized for either vocals or instruments.

Bass - Boost/Cut: +12/-14 dB

VOCAL mode (Bell curve)

Frequency range: 50 Hz to 800 Hz

INSTrument mode Shelving EQ

Frequency range: 25 Hz to 400 Hz

Presence - Boost/Cut: +12/-15 dB

Bell curve Frequency: 1.5 kHz

Treble Boost/Cut: ±14dB

VOCAL mode Shelving EQ frequency: 10kHz

INST mode (Bell curve) frequency: 3.3kHz

Optional A/D Converter

For Penta, VoiceMaster PRO and Trak Master

The optional high quality, 24-bit/96kHz and 128x over-sampled A-D converter card handles sampling rates of up to 96kHz with an S/PDIF output. Available for the Platinum Penta, VoiceMaster PRO and Trak Master, the board is easily retrofitted without soldering etc. Just a few screws to undo and one clip to connect.

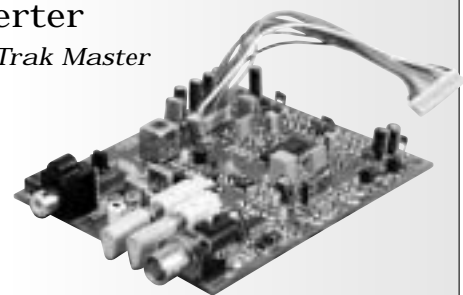

FOCUSRITE

PLATINUM QUICK REFERENCE GUIDE

	OctoPre	Mix Master Digital	Penta	Compounder	Voice Master Pro	Trak Master
Mono/Stereo	8 mono stereo	Stereo	Mono/Stereo	Dual Mono/Stereo	Mono	Mono
Mic Preamp	Yes, 8	No	Yes	No	Yes	Yes
Instrument Input	Yes, via 25-pin d-sub	No	Yes	No	Yes	Yes
Line	Yes, via 25-pin d-sub	+4db/-10db	+4db/-10db	+4db/-10db	+4db/-10db	+4db/-10db
Compressor Type	Opto w/Limiter	MultiBand Opto	Opto	VCA	Opto	Opto
Gate	No	Expander	None	Gate	Expander	none
Saturation	No	None	TubeTran Valve Warmth	None	Voice Optimized	TubeSound
24 bit/96 kHz Digital A-D Option	Yes, 2 available	Included	Yes	No	No	Yes
Filters	No	No	Hi Pass	No	Hi-Pass	No
Parametric EQ	No	1x Full Range	No	No	Voice Optimized 3-band	Yes
Passive EQ	No	No	No	No	No	No
Bass Enhancement	No	Yes	No	Huge	No	No
Presets	No	No	Yes	No	No	No
Stereo Image Widening	No	Yes	Yes	No	No	No
De-esser	No	No	No	No	Yes	No
Gate Key Input	No	No	No	Yes	No	No
Comp SideChain Input	No	No	Yes	No	No	No
Limiter	Yes, in Compressor circuit	Yes	No	No	No	No

RED 2 *Dual-Channel EQ*

The Red 2 brings two full channels of the classic Focusrite EQ to any mixing and mastering system requiring world-class equalization. Both channels feature transformer balanced inputs and outputs,



ensuring excellent electrical isolation and sonic clarity and buffering between EQ bands.

The Red 2 features EQ circuits identical to those found on the classic ISA 215 dual channel mic-pre/EQ processor. A frequency response from 5 Hz to 200 kHz ensures linear audio response resulting in the classic Focusrite smooth, open high-end with no phase problems. The high and low shelving bands employ switched capacitor circuits rather than conventional variable resistor capacitor circuits, resulting in a filter curve shape that provides smooth and predictable results.

- ◆ Transformer-balanced inputs and outputs provide superb isolation while contributing to the warm sonic signature of the Focusrite EQ. (Many run their signal paths through the Red 2 to obtain this warmth whether or not they are applying EQ).

Input Gain: ±12dBu continuously variable
Input Impedance: 10kΩ ±15%, 20 - 20k Hz
Balance: >60dB
Frequency Response: 5Hz to 200kHz
Noise: Better than -98dB below +4dBu
Output: +26dBm with 600Ω output load

- ◆ Derived from the classic ISA 110, the Red 2 offers switched-frequency high and low-pass filters, switched frequency shelving bands for low and high frequencies, and two fully parametric mid bands with frequency sweep and Q controls.
 - The shelving high and low bands offer up to 18dB cut and boost from 3.3 -18kHz and 33 - 460Hz respectively, with a constant filter curve shape —unaltered by frequency selection —for smooth, predictable results.
 - The two fully-parametric, mid bands have considerable overlap in available frequency selection. The low-mid band is sweepable from 40-400Hz or (x3)120Hz -1.2kHz.
 - The high mid band is sweepable from 600Hz-6kHz or (x3)1.8kHz-18kHz. The bandwidth (or Q) is continuously variable from 0.3 to 1, allowing a broad or very fine “peaking” or “dipping” curve to be obtained with up to 18db of gain or attenuation.
 - The high and low-pass filters provide 12db per octave attenuation and are switchable in steps between 36 -330Hz and 5.6- 2200 Hz.



ONE HOUR FREE PARKING

AT 349 W. 34th STREET (with purchase of \$100 or more)

FOCUSRITE

RED 1 • RED 8

Quad and Dual Mic Preamps

High resolution digital audio workstations such as Pro Tools offer very accurate and detailed audio quality. When recording at increased resolutions, it is important to use high-end mic/line preamplification to ensure that the most precise signal possible is being fed into your audio interface. The Focusrite Red 1 and Red 8 respectively



provide four or two perfectly matched channels of perhaps the most sought after mic preamplification in the audio industry. Using the same circuit topology as found in the ISA 215 mic preamps, the ultra-high quality Red 1 and Red 8 provide a transparent link between the microphone and the recording destination. Their transformer-based inputs and outputs provide superb isolation and ultra-wide bandwidth. Used with high quality ribbon, valve and condenser mics, the Red 1 and Red 8 obtain outstanding results with any sound source, but especially voice, piano and string instruments. With their distinctive deep burgundy, anodized aluminum chassis and solid design, the Red 1 or Red 8 are at home in any critical audio recording application when the ultimate sonic integrity is in demand.

FEATURES

- ◆ With two or four mic pre-amps in a single unit, the Red 8 or Red 1 is ideal for those looking for improved audio performance, as a compact 'way in' to digital recording systems, or for location multi-mic recordings.
- ◆ Each channel offers custom-wound Focusrite input transformers, switchable phantom power, phase reverse, and easily-read illuminated VU meter, and a handy scribble disc for denoting channels.
- ◆ Mic gain is switched in 6dB steps over a 66dB range, for accurate, precise channel matching and recall.
- ◆ Benefits of the unique Focusrite mic amp topology include superb common-mode rejection, a good overload margin and, with its shared gain structure, (20dB from transformer and up to 40dB from the amplifier) a very low noise floor with the signature wide bandwidth (10Hz to 200KHz).
- ◆ High performance levels are maintained with a very wide range of impedance across the inputs.
- ◆ Output stages with their custom transformers can drive long cable runs—several kilometers—without significant loss of quality. Makes them ideal for remote recordings.
- ◆ The Red 8, with a perfectly matched pair of mic amps, offers identical channel controls to the Red 1, and is especially suited to demanding mono or stereo recording work, such as location classical recording with digital recording media.

What makes the Red Range so special?

- The Red Range is handmade, crafted to the highest standard. Red processors are made in England using machine-tooled, half-inch thick bordeaux red anodized aluminum.
- All potentiometers are made from conductive plastic which gives more sensitivity and no mechanical resistance (easy to make very small adjustments).
- The chassis features recessed section grooves and styling motifs, porthole windows, printed silver control text, and firm-response illuminated switches.
- They feature sealed relays (gold-plated silver in an inert gas), situated in the middle of the circuits in which they switch. The precious metals mean that all contacts are low resistance, and the gas prevents any kind of corrosion of the surface of the contacts, meaning the most perfect audio switching device ever designed—utterly passive, zero distortion caused and no FET's required.

ORDER & INFO. (212) 444-5088 • FAX: (212) 239-7770 (800) 947-7008
1-800-875-6951 • www.bhphotovideo.com



FOCUSRITE

RED 3

Dual-Channel Compressor/Limiter

Employing an unusual and original single-VCA design, the Red 3 provides two perfectly matched channels of exceptional-quality and truly independent compression and limiting. Incorporating a TEC



award-winning Class A VCA design results in a short signal path and extremely low noise, allowing the Red 3 to achieve truly transparent compression/limiting.

True stereo compression is provided from a single set of controls, ensuring perfect phase coherence between both channels when working with stereo audio signals. A frequency response of 5 Hz to 200 kHz provides excellent linear audio performance. With its distinctive deep burgundy, anodized aluminum chassis and solid design, the Red 3 is at home in any critical audio recording application when the ultimate sonic integrity is in demand.

FEATURES

- ◆ The Red 3's VCA is a proprietary Focusrite design, fully discrete and balanced, offering superb low noise and distortion, and excellent common-mode rejection.
- ◆ In order to separate compression and limiting, the side-chain electronics contain three VCAs in series to generate compression and limiting control voltages which drive the main VCA. The result is true compression followed by limiting, rather than the more common characteristic of compression that turns into limiting.
- ◆ The side-chain electronics are Class A, ensuring superb transient response. Both compression and limiting therefore, offer true peak response, not averaging RMS response. The use of such a high quality audio VCA as the only element between input and output means a very short signal path, and an ability to retain a natural, unobtrusive sound even when significant compression is being applied.
- ◆ Each channel has clear and identical controls, for compressor ratio, threshold, make-up gain, attack and release, and limiter threshold.
- ◆ A program-dependent auto-release mode is available, and the VU meters can be switched to show levels in two ranges, or gain change. In stereo mode the lower set takes control of both channels.

BLUE 230 Broadcast Dual-Channel Compressor/Limiter



The Focusrite Blue 230 is a special version of the Red 3, optimized for broadcast applications. It features the same award-winning signal path, but with switched control of critical parameters for improved recall.

- ◆ Key to the broadcasting facility is the ability to recall/notate precise settings. A higher level of control markings across the front panel provide the user with preferred level of information, while both Threshold and Ratio potentiometers are stepped for precision control and optimum resetability.
- ◆ MU metal cans around all transformers reduce all electromagnetic radiation
- ◆ Another key requirement for broadcast is electronic isolation. The Blue 230 features transformers at both the input and output stage, ensuring total isolation and an absolute minimum level of ground-related hum.
- ◆ Machine-tooled in half-inch thick, deep blue anodized aluminum, which is scratch-resistant and can be marked and unmarked forever.
- ◆ Chassis features recessed section grooves and styling motifs, porthole windows and firm-response illuminated switches.
- ◆ Relays are gold-plated silver in an inert gas, which means that the contact is low resistance, and the gas prevents any corrosion of the surface of the contacts – the most perfect audio switching device ever designed – utterly passive with zero distortion.

Mic Preamp and Channel Strip

The Red 7 combines a single channel of classic Focusrite microphone preamplification (the same superb mic preamp as the ones on the Red 1 and Red 8) with a full



dynamics section, optimized for vocals. In addition to the mic preamp, the Red 7 features a single channel compressor from the Red 3 and adds a de-esser/exciter. So now you can get the warmth of classic Focusrite mic preamps and the transparent, smooth characteristics of their compressors in one affordable package. With its superb signal path, outstanding ease of use, and integrated all-in-one design, the Red 7 is a powerful tool for voice recording in all situations from music studios to post-production.

- ◆ Features the classic Focusrite transformer-based inputs and outputs for outstanding isolation and superb sonic performance.
- ◆ The Red 7 employs the same superb mic pre-amp as the Red 1 and 8, with a dual-range mic gain pot that allows precise control across the full range of the device. Phantom power and phase reverse are also provided.
- ◆ The Line input is electronically balanced, with continuously variable gain. A high quality output fader offers +6dB gain to infinite attenuation, essential for direct recordings, or for accurate level matching after EQ and dynamics.
- ◆ The compressor design is taken straight from the Red 3, and as on that unit, is characterized by low noise and distortion even with heavy processing. Relatively heavy compression can be applied while retaining a transparent natural sound. Ratio, gain make-up, threshold, attack and release are all continuously variable, and a program dependent auto-release mode can be switched in. A swept high-pass filter allows effective treatment of problems such as rumble, bass lift and proximity effect.
- ◆ Illuminated push-button switches for compressor in/out, de-esser/exciter in/out and high-pass filter in/out.
- ◆ The de-esser/exciter stage can be switched to provide frequency-selective compression (de-essing) or excitation. The amount and center frequency of the processor are continuously variable, and as all the unit's dynamics still use the Focusrite single-VCA technique, unwanted coloration of the sound is kept to an absolute minimum.
- ◆ A clear VU meter shows level after the pre-amp gain control, or display compressor gain change.

	Red 1	Red 2	Red 3	Red 7	Red 8
Mic Input Gain	-6dB to +60dB in 6dB steps	Not Applicable	Not Applicable	-6dB to +60dB in 2 variable ranges	-6dB to +60dB in 6dB steps
Mic Input Impedance	1200Ω ±15%, balanced and floating	Not Applicable	Not Applicable	1200Ω ±15%, balanced and floating	1200Ω ±15%, balanced and floating
Frequency Response	10Hz to 140kHz (-3dB points), ±0.1dB within passband	5Hz to 200kHz (-3dB points) ±0.1dB within passband	5Hz to 200kHz (-3dB points)	10Hz to 140kHz (-3dB points), ±0.1dB within passband	10Hz to 140kHz (-3dB points), ±0.1dB within passband
Noise (EIN)	-127dBu (input loaded 200Ω) @ 60dB gain	Better than -98dB below +4dBu	Better than -80dB below +4dBu output level	Better than -80dB below +4dBu output level dynamics level	-127dBu (input loaded 200Ω) @ 60dB gain
Distortion	0.15% (-20dBu @ 20Hz) 0.06% (-20dBu @ 40Hz) 0.003% (-20dBu @ 1kHz) 0.005% (-20dBu @ 10kHz)	0.016% (-20dBu @20Hz) 0.02% (-10dBu @20Hz) 0.03% (0dBu @20Hz) 0.03% (0dBu @20Hz)	0.02% with input at 0dBu at 1kHz 0.006% (+10dBu @ 1kHz) 0.004% (+20dBu @ 1kHz)	0.006% (+10dBu @ 1kHz)	0.15% (-20dBu @ 20Hz) 0.06% (-20dBu @ 40Hz) 0.003% (-20dBu @ 1kHz) 0.005% (-20dBu @ 10kHz)
Output	+24dBm into 600Ω +26dBm into 10kΩ, balanced and floating	+26dBm with 600Ω output load balanced and floating	+24dBm with output loaded 600Ω, balanced and floating	+24dBm into 600Ω +26dBm into 10kΩ, balanced and floating	+24dBm into 600Ω +26dBm into 10kΩ, balanced and floating

FOCUSRITE

ISA 220: SESSION PACK

Channel Strip

The ISA 220 Session Pack provides all the audio precision tools required to infuse your session with Focusrite's renowned sonic



performance. It features many of the original circuits of the flagship ISA 430 Producer Pack, and also includes some new facilities of its own. It also features the same digital output option as the ISA 430, providing you with a high quality digital route direct from the ISA 220 into your digital recording system.

With a topology based on the flagship ISA 430, the ISA 220 is designed for professionals in music and post. A channel strip style processor, the 2RU high ISA 220 includes a transformer-coupled mic/line/instrument preamp, 4-band EQ with filters, compressor, optical de-esser and frequency adaptive limiter.

FEATURES

Input Stage

- ◆ Input stage features a precise VU meter, switchable to allow monitoring of either input level or compressor gain reduction
- ◆ Above the VU meter is a 32 LED digital meter for monitoring both the 'internal' input and the rear panel 'external' input (the latter routes directly to the second channel of the optional A/D card).
- ◆ A global bypass switch next to the digital meter allows for instant A/B comparisons
- ◆ Mic, line and instrument inputs are all transformer-based, the cornerstone of the Focusrite signature sound, clear yet warm, with incredibly low noise figures and a THD below 0.001% on the mic input!
- ◆ Switching between these input options is available on the front panel with LED's indicating the active input.
- ◆ The Mic Pre is the classic Focusrite transformer-based design with illuminated switches for phantom power and phase reverse, all available on the front panel
- ◆ From the front panel you also have control over the digital output option and in/out selection for each of the processors. An instrument jack is also provided on the front panel for quick 'plug and play' access.

De-esser

- ◆ Same De-esser as the ISA 430, based on a low distortion optical technology design, letting you transparently remove excessive sibilance from a vocal performance.

EQ Section

- ◆ The EQ featured on the ISA 220 is similar to the ISA 430 and ISA 110, with the exception of the Shelving EQ's having four frequency selections rather than six. Whether fattening-up bass, fore grounding or trimming middle, or adding airy top, this EQ can handle anything with grace and ease.

Compressor

- ◆ Next to the compressor section (the same compressor as the ISA 430) is a 'Compressor Pre EQ' switch. This allows you to place the compressor either pre or post-EQ.
- ◆ Alongside the auto release is the Blend control, a unique function in the ISA 220 that allows smoother compression at more extreme settings. When switched in, 'Blend' lets you mix the uncompressed signal with the compressed, thus retaining the power of the dynamics from the original source.

Output

- ◆ The output section of the ISA 220 features the same frequency adaptive limiter as the ISA 430, a design which uses three separate stages of optical-based circuits, each of which has different limiting properties to give true distortion-free limiting.
- ◆ Fast limiters tend to have problems dealing with complex signals that contain sustained low and mid frequency information and thus "chop holes" in the audio when HF transients trigger the limiting. To overcome this, the ISA 220's frequency adaptive limiter has three frequency bands with different attack times as follows: LF slow, MF quick and HF ultra-quick, the latter designed to catch fast transients. An upper threshold is fixed at +20dBu to prevent overload of the internal (or an external) A/D converter. Finally, a variable control adjusts the module output level between -60dB and +6dB ensuring optimum output levels.

OPTIONAL ISA 220 A/D CARD

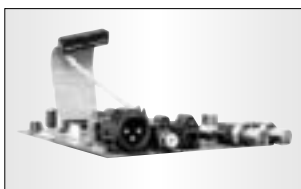

An optional 24-bit/ 96 kHz digital output (AES/EBU, S/PDIF and TOSLINK) offers 44.1 - 96 kHz operation, 16, 20 and 24 bit resolution selection and can lock to external Word Clock, including Pro Tools Super Clock. It can be used as a high-quality mono/stereo tracking converter or at mix down as a stereo converter for final mastering.

FOCUSRITE

ISA 430: PRODUCER PACK

Super Channel Strip

Stepping up from the ISA 220, the ISA 430 adds proprietary Focusrite discrete Class A VCA Gate and Expander designs, plus a host of very thorough routing and monitoring options.



The discrete insert send and return may be placed before EQ or Dynamics, between the two or after both. Each band of the EQ, including the filters, can be routed to the sidechain of the compressor or gate for accurate drum gating or frequency selective compression. The classic, large analog VU meter can be switched to display input, insert return or gain-reduction level. "Listen" mode allows monitoring of the sidechains of the Compressor, Gate and De-esser so that accurate frequency adjustment can be made when tailoring the various dynamic effects. Another very unique feature of the Producer Pack's routing capability is "split mode". The ISA 430 can be run as a single channel "Producer Pack" or split, to act as two independent processors running discrete audio paths.

SAME FEATURES AS THE ISA 220 PLUS—

- ◆ The Gate section uses the Focusrite Class A VCA as the control element to remove the effect of unwanted interference and high levels of wide-band system noise build-up. The Gate acts as a straight-forward on/off control, switching off the audio path when the signal level drops below the threshold set, killing noise in the quiet passages of a performance.
- ◆ Switching this section to expand mode causes the Gate to function as an Expander, which gives a more gentle gating effect; instead of cutting any signal below the threshold, an expander proportionately decreases it. This will give a more natural sound when reducing noise from non-percussive sources (especially vocals). The adjacent LED meter indicates in dB the amount of gain reduction caused by the Gate/Expander. As with the compressor, this section offers both the 'Listen' and 'Ext key' features.
- ◆ 'Hysteresis' increases the level-difference between the gate switching on and off, and prevents the gate oscillating ('chattering') with particular combinations of input signal and threshold settings. This function is particularly useful when gating a signal with a very long decay time and large amounts of level modulation (for example a Grand Piano).

Insert, Pre EQ and Split Dynamics Switches

The ISA 430's real benefit as a "do-all" processor for demanding engineers are the insert, pre EQ and split dynamics switches for controlling the position of the sections within the signal flow.

Insert Position

The Insert Send and Return can be positioned in three places within the signal flow for maximum versatility.

Pre—Insert is after the input trim, but before EQ or Dynamics

Mid—After EQ but before Dynamics

Post—After EQ and Dynamics but before the main output

Dynamics Pre EQ

Normally the EQ section precedes compression. Pressing Pre EQ reverses the position of the EQ and Dynamics sections, placing Dynamics first and EQ afterwards. This function gives greater flexibility in the order of the processing blocks and the relative position of the insert point when combined with the Pre, Mid and Post selector, allowing EQ changes to be independent of compressor section

Single/Split Mode Selection

The ISA 430 can be run as a single channel "Producer Pack", or split to act as two independent processors running discrete audio paths. Split mode allows the Insert Return and Insert Send to act as independent inputs and outputs to the dynamics section only, creating two devices in one, with separate EQ and Dynamics channels—perfect for mix down problem solving.

ISA 220 AND ISA 430 SPECIFICATIONS

Inst. Hi Z input		Compressor		De-Esser	
Noise:	-96dBu	Threshold		Threshold Range:	22dB
THD:	0.003% with 0dBu	Range:	-28dB to +12dB	Frequency Range:	2K2 to 9K2
		Ratio:	1.5:1 to 10:1	Ratio at Center Frequency:	2:1
		Slope:	Soft knee		
		Attack:	500µS to 25mS		
		Release:	100mS to 4S, variable or auto (program dependent)		
Mic				Limiter	
Noise:	123dB EIN with 150Ω input resistance at 60dB of gain			Threshold Range:	20dBu
THD:	0.0008%			Ratio:	infinite (Brick Wall)
				Attack:	Frequency dependent

FOCUSRITE

ISA 428: PRE PACK

4-Channel Mic Preamp

The ISA 428 Pre Pack features four Rupert Neve-designed, transformer-based microphone preamps with selectable impedance,

direct instrument and line inputs, and an optional 8-channel 192 kHz analog-digital converter. An all-new Soft Limiter circuit precedes the A-D, providing the perfect path into any DAW, digital console or stand-alone hard disk recorder.

The ISA428 also functions as the perfect input expander for mixing consoles, featuring the four mic pres, four instrument inputs, and 8 line inputs. Any combination of 8 of these inputs can be routed discretely to the optional 8-channel A-D converter. Equally suited for traditional stand-alone preamp roles in broadcast, post-production, live sound and installations.



FEATURES

Four Classic Neve-Designed Mic Preamps

- ◆ Incorporates four of the original Rupert Neve-designed transformer-based preamps found in the classic ISA110's. The benefits of this pre-amp topology include superb common-mode rejection, an excellent overload margin, and, courtesy of the shared gain structure (20dB from the hand-wound transformer and up to 40dB from the amp), an extremely low noise floor and super-wide bandwidth. This pre-amp design is the cornerstone of Focusrite's signature 'warm-yet-transparent' sound and is a standard point of reference for many of the industry's most discerning audio professionals.
- ◆ Four front panel instrument inputs—no separate DI box required.

Switchable Impedance

- ◆ The input stage also provides enhanced control and creativity, by allowing you to switch between four carefully selected input impedance settings—the original ISA110 setting plus three more impedance settings, to either perfectly match the pre-amp with any microphone (and so maximize level,) or to use different settings creatively to interactively shape the sound of your chosen classic mic.
- ◆ Switchable insert points are also featured on every channel, allowing routing, (between pre amp and output,) to additional external processing if desired.

- ◆ Full output metering for all 8 channels is provided by 6-segment LEDs on the ISA428's front panel, while input levels can be tracked using 'moving coil' peak reading VU-style meters, designed to catch even the fastest and most elusive of transients.

- ◆ Two ISA428's can be used with a single A-D converter utilizing the four extra line input channels on the rear of the unit containing the optional A-D converter. This allows expansion from a 4-pre system to an 8-pre system – hence the name "Four t(w)o Eight!"

Custom Global Soft Limiting

- ◆ Protecting the A-D circuit is Focusrite's "Soft Limiter," a custom optical design, which both protects the A-D converter by preventing 'digital overload', and also eliminates the unpleasant distortion that standard limiter circuits often generate. Alternatively, it provides worry-free, musical A/D conversion, handling even the hottest analog signals with style and grace.
- ◆ Rather than simply protecting the A/D in a brick-wall fashion, the Soft Limiter tailors the last 6dB dynamic range of the A/D converter to cater for the last 12dB of analog headroom. This ensures the A/D converter never overloads at any point during the analog performance. Unlike conventional limiters, it provides an absolute limit without destroying the audio integrity of the source signal.

Optional 8-channel 192kHz A-D Converter

- ◆ Embodying cutting-edge conversion technology, encompassed within pristine Focusrite circuitry, the optional A-D converter provides eight channels of the highest quality conversion at sampling rates of 44.1, 48, 96 and 192 kHz. (Running at 96kHz provides 16 simultaneous digital outputs alongside the four main analog outputs.) Digital output formats include 8 channel single/dual wire AES/EBU, S/PDIF and ADAT lightpipe, all available on a single card.

ISA 428 INPUTS:

GAIN RANGE		INPUT IMPEDANCE	
Line	±18dB	Line	10K Ω
Mic	0 to 60dB (both in 6dB steps)	Mic	Variable -600 Ω, 2K4 Ω, 6K8 Ω and original ISA110 settings
Inst	+10 to +40 dB variable	Inst	>1M Ω
NOISE			
Line	-96dB	Mic	-128dB (EIN with 150 Ω input resistance at 60dB of gain)

RADIUS 3 FAT MAN

Stereo Tube Compressor



The Radius 3 Fat Man provides instant access to 15 high quality, stereo tube compression presets, making it easy to add fat, professional sounding tube compression when tracking, mixing or playing live. Created in consultation with leading audio engineers, including Pink Floyd's Andy Jackson, the programs ensure a polished, professional sound to your mix. The pre-sets include optimum compression settings for vocals, keyboards, bass, acoustic and electric guitars, snare, kick and whole drum kits and pop, rock and dance mixes, making the Fat Man a very user-friendly tube compressor.

For those who wish to create their own compression settings, a manual mode provides fully adjustable control over threshold, ratio, knee, attack and release settings. Input / output gains and gain make-up controls remain adjustable in both preset and manual modes to allow gain balancing for different systems. A bypass switch is provided to compare compressed and direct signals and a vintage-style VU meter can be switched to meter output level or the amount of gain reduction. In addition to line inputs and outputs, the Fat Man also features front panel instrument inputs for the direct injection of guitars, basses and keyboards.

- ◆ Balanced 1/4" analog I/O, unbalanced compatible
- ◆ -10 / +4dBu switchable
- ◆ 1/4" jack instrument inputs
- ◆ 15 preset settings and a manual mode
- ◆ Compressor with adjustable threshold, ratio, attack, release and knee
- ◆ Adjustable input and output gain
- ◆ Gain make up
- ◆ VU metering of output level or gain reduction
- ◆ Compressor bypass
- ◆ Optional 19" rack-mount kit holds 2 units

RADIUS 5 FAT MAN 2

Tube Preamp and Compressor



The Fat Man 2 is an affordable, high quality tube preamp and compressor, offering an ideal way of adding tube warmth and punch to recordings and live performances. It can also be used as an instrument preamp, a vocal processor or as a 'warm' front end for a digital recording system. The Fat Man 2 has 15 high quality presets, including five vocal compression settings, with other presets for guitars, keyboards, basses and drums. A fully manual mode controls individual compression parameters, including the threshold, compression ratio, knee, attack and release settings. Input and output gains are adjustable in both manual and preset modes, while a gain make-up

control enables quick and simple balancing of the original and the processed signals.

The first stage of the Fat Man 2's dual-stage 12AX7A triode tube is housed in the preamp, with the second stage in the compressor section. The tube preamp accepts mic, line and instrument inputs. A source switch selects either the mic or line input and also adjusts the sensitivity for the instrument input between high and low. Phantom power is switchable and there is a 90Hz high-pass filter to remove unwanted rumble or hum.

JOEMEEK

SC2 • SC2.2

Stereo Optical Compressors

The JOEMEEK SC2 and SC2.2 are two channel stereo photo-optical “effects” compressors designed, not to perform protective functions like modern VCA compressor/limiters, but to be used as artistic tools that produce the psychoacoustic effect of power and dynamics while at the same time, retaining sparkle and adding warmth to your audio tracks. Due to the very nature of photo compression along with the use of modern servo control techniques and electronically-balanced operation, the SC2 and SC2.2 are virtually free from noise and distortion. Both units are easy to setup and operate with variable input and make-up gain, attack and release controls as well as JoeMeek’s unique interactive Compression Drive and Slope (ratio) controls. The SC2.2 also features a ‘Dark Mode’ switch that allows you to choose between the classic JoeMeek sound and a modern ‘bright’ punch mode that allows more precise level control. Both units offer the distinctive JOEMEEK sound (and bright green faceplate) that cannot be duplicated by any of today’s digital technology. The SC2 is considered the “Classic” JoeMeek compressor which delivers uncompromising audio quality sought after by top producers, engineers and musicians throughout the world. The SC2.2 uses the same cell compressor design as the SC2 but is made more affordable by only offering XLR outputs (as opposed to XLR and 1/4” TRS) and uses a smaller chassis.

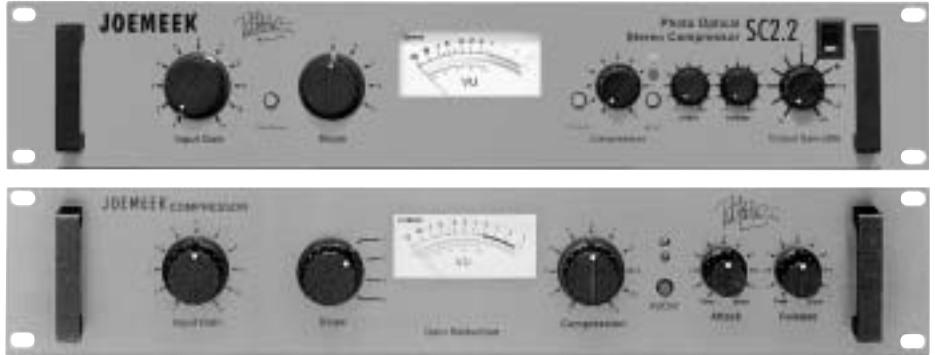

FEATURES

The Stereo Compressor

- ◆ Recreates the warmth and power of the 60’s style analog tape and compressor combination without the side effects — Photo-electrical compression is achieved using modern servo-control techniques that ensure the accuracy and speed of response of the light source
- ◆ No distortion producing voltage controlled amplifiers (VCAs) are used. Although the compression is non-linear, the effect is true volume compression with no “limit” action
- ◆ Before the left and right channels are introduced to the compression circuit, they are converted to ‘sum and difference’ mode. This ensures that the centre image stays perfectly in the centre even under heavy compression. The sum and difference coded signal is compressed, and then converted back into ‘left/right’ format

Controls

- ◆ Since the two compressor channels are linked as a stereo pair, a single control is provided for each parameter that controls both the left and right channels
- ◆ Separate rotary controls are provided for adjusting input gain (approx 20dB max) and output (make-up) gain (+26dB max)
- ◆ The rotary Attack control is adjustable between 1.5 and 10 ms
- ◆ The rotary Release control adjusts the recovery time of the compression. The wide range gives the option of high speed “pumping” down to very slow gain riding
- ◆ An In/Out ‘hard wired’ bypass switch allows instant comparison between the original uncompressed, and the compressed signals

Interactive Compression Control

Instead of the standard ‘threshold’ and ‘ratio’ controls, found on conventional compressors, JoeMeek compressors use interactive Compression and Slope controls that work together in a musical, non-linear (non-predictive) manner.

- ◆ The rotary Compression control adds drive (gain) to the optical system. It not only controls the ‘Threshold’ level, it helps define the ‘knee’ characteristic of the compressor causing the ratio to increase along with program content and amplitude. In simple terms, winding up the compression control increases the amount of compression
- ◆ The 4 position rotary Slope switch is similar to a ratio control but is not linear as it reacts with the Compression control — At the lowest rate (1), the maximum compression ratio is about 2:1 with a maximum possible compression of about 6dB. At the highest rate (4), the compression ratio usable maximum is about 8:1

Inputs & Outputs

- ◆ Dual XLR and 1/4" TRS balanced line level inputs and outputs are provided on the rear panel but can be operated unbalanced without loss of quality (the SC2.2 has only XLR ins and outs)
- ◆ Inputs are precision-electronic balanced using the "Superbal" principle, invented by Ted Fletcher in 1976, that delivers excellent noise rejection and sonic performance
- ◆ Outputs are electronically balanced and floating at a source Impedance of 100 Ω

Metering

- ◆ A large illuminated VU/COMP meter is switchable between reading audio input level and gain reduction for both channels

System Performance (same for both units)

System Gain	Max. 20dB
System Noise (20Hz to 20kHz)	Generally better than -94dBu
System Distortion	Within 0.004% 100Hz to 10kHz at all levels
Frequency Response	Substantially flat 5Hz to 30kHz with minimal phase shift at extremes
Crosstalk	Better than -60db at 10kHz
Push button Hardwire Bypass with LED indication	Blue (in operation) Red (bypass)
METER VU/compression meter	Switchable between input level or gain reduction
Power	115/230VAC (switchable) 10 watts
Housing	2RU Steel case enclosure

Additional

- ◆ The units can be used as single mono processors by just driving one side only
- ◆ A mains voltage selector lets you change the input voltage to operate between 95 and 125V and between 210 and 240V AC

The SC2.2 Adds

- ◆ The Dark Mode switch gives the option of using a 'conventional' sounding compression effect, or the more dramatic and original 'JOEMEEK' sound — In 'Dark Mode', the time curve for the release of the compression behaves in a much less predictable way
- ◆ A fifth slope position has been added for achieving extreme compression effects — The attack time is also faster adding to the fifth slope positions more whacky effect sound
- ◆ Detented pots make it easier to return to preferred settings

The JoeMeek Compressor: What It Does

Anyone who has tried to record a human voice in the simplest possible way has found that the dynamics of real world speech and music are impossible to handle with a 'linear' recorder: Even if the signals do not overload, the final result is a recording that seems to be thin, quiet and too wide in dynamic range.

Early analogue tape recorders had a built-in answer to the problem, Slightly overloading the record channel produced (predominantly) 2nd order harmonic distortion and some volume compression. This made recordings sound 'warm' and reduced the problems of dynamics. Unfortunately (?), modern recording mediums don't react that way; they produce an accurate reflection of the input with all its built in problems.

Most thinking engineers know of these problems and correct with the use of equalisers (to change the psychoacoustic distance from the microphone), limiters (to reduce dynamic range at the louder end) and enhancers (to sparkle it up). And then find that it is extremely difficult and time consuming to get a warm and cosy sound**.

Joe Meek, in common with all engineers, experimented with the limited facilities of the time (1960 - 1965) and came up with a way of enhancing the 'tape bend' effect with compression. The compressor he used was primitive in the extreme, but coupled with the compression distortion provided by the valve tape machines he had, the

result was voice and music sounds that were unique and sold records by the million.

I had to make some significant improvements in the way the early compressors worked to make the JOEMEEK acceptable to today's engineers, but now that they are in general use in top studios all over the world, the consensus is that the sound is right, and really does recreate the warmth and power of the old equipment without the side effects.

** The classic way is to use a U47 or similar large diaphragm capacitor microphone; which in itself 'distorts' the sound with complex high frequency phasing across the diaphragm and some 2nd order distortion from the amplifier tube.

There are probably hundreds of types of compressor/limiters on sale in the world, all struggling for a place in the market with extra knobs and facilities and all missing the fundamental point;- that a compressor is there to produce a psychoacoustic effect of power and dynamics. not to perform any protective function electronically; it's a creative tool.

The JOEMEEK recreates the dynamics of the old analogue tape and compressor combination. And yes; it is entirely possible that one day this algorithm could be written for a digital processor —but would it be as easy to use?

JOEMEEK

VC1Qcs

Studio Channel with Current Sense Mic Preamp

The VC-1QCS "Studio Channel" offers six separate pieces of equipment all in one 2U 19" package: a CurrentSense Microphone Preamp, a JOEMEEK "photo-optical" Compressor,

Instrument Pre-Amp, a JOEMEEK Enhancer / De-esser and a full channel of the 3-band JOEMEEK Meequalizer "EQ". Other features include balanced XLR and 1/4" TRS line-level outputs, comprehensive input and gain reduction metering as well as LED status indicators for each processing stage. In addition, an optional (VC1QD) card, that plugs right into the rear of the VC1QCS, provides a 24 bit 96K digital SPDIF output so you can connect the Studio Channel directly to your DAW.



FEATURES

CurrentSense Preamp Design

- ◆ Optimizes microphone performance by automatically loading the correct impedance to required by the microphone
- ◆ A floating balanced input easily accepts microphone levels from -70dB up to more than 0dB and provides (microphone) input headroom of more than 30dB
- ◆ Other benefits include a more even and extended frequency response as well, any mic can be used regardless of impedance requirements and cable resistance/quality is no longer relevant
- ◆ Individual switches with LED indicators are provided for mic/line selection, phantom power, a hi-pass filter, and phase reverse
 - > The 12dB per octave (3dB down at 75Hz) High Pass Filter removes extreme rumble frequencies
 - > A Phase Reverse switch allows you to reverse the signal polarity

Compressor

- ◆ The Compression control adds gain to the compression sidechain thereby increasing the compression effect
- ◆ A five position Slope control sets the ratio from gentle compression to pumping effects
- ◆ The Attack control sets the time that the compressor takes to act
- ◆ The Release control sets the amount of time it takes gain to return to normal after compression

Enhancer / De-Esser

- ◆ The enhancer uses a drive and resonance control that, when used judiciously, allow you to add a unique sparkle and brightness to sounds that seem otherwise "flat". The effect is particularly well suited for vocals, guitars and acoustic instruments
- ◆ The enhancer works by picking off the higher frequency part of the sound, compressing and dynamically altering it, filtering off the original sound and remixing the resulting harmonics back with the signal.
- ◆ De-essing is made possible by turning the enhancer pot counter-clockwise

The EQ

- ◆ One complete channel from the 3-band VC5 "Meequalizer" delivers a musical sound, unlike any software plug-in or analog project studio mixer EQ
- ◆ The Treble control is a shelving filter with a boost/cut of approx ± 18 dB at a fixed frequency of 8kHz
- ◆ The Mid band is a sweepable EQ filter with a boost/cut of approx ± 16 dB and a frequency control variable from 600Hz to 3.5KHz sweep variable. The Q (bandwidth) value of the mid frequencies varies (increases) with frequency.
- ◆ The Bass control is a shelving filter with a boost/cut of approx ± 18 dB at a fixed frequency of 100Hz
- ◆ An In/out switch (bypass) with indicator is provided

Metering

- ◆ A large illuminated VU meter is switchable between reading audio input, and gain reduction (compression)

Gain Make-Up

- ◆ A high quality make-up gain amplifier with a level control, located post-VU meter, allows you to compensate for gain changes due to compression or EQ

Inputs & Outputs

- ◆ The Studio Channel is optimized for the three main types of inputs found in recording studios —
 - > XLR microphone inputs are available on the front and rear of the unit
 - > A balanced 1/4" TRS line input is provided on the rear
 - > An unbalanced 'instrument' input is also provided on the front panel
- ◆ A 1/4" TRS and an XLR connector provide high level electronically balanced line outputs
- ◆ A 1/4" TRS insert point allows you to add an external processor into the signal chain

24-bit / 96kHz Digital Output

- ◆ The user-installable VC1QD digital option card allows you to add a 24-bit S/PDIF or AES/EBU output with a 115 dB dynamic range
- ◆ One switch allows you to select 44.1, 48 kHz sample rates while a x2 switch doubles the sample rates to 88.2 or 96kHz

Dual Studio Channel with Current Sense Mic Preamp

The TwinQcs offers JOEMEEK's Studio Channel in a compact, dual channel format. Each channel features the same 'CurrentSense' mic pre as in the VC1Qcs, with the ability to optimize its impedance

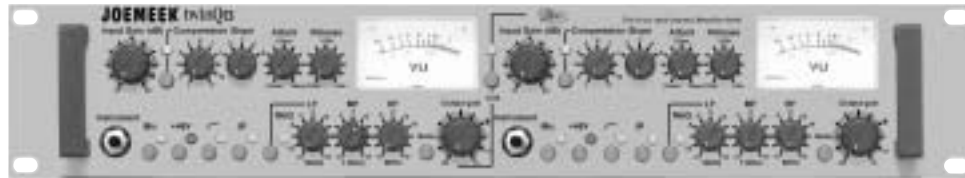

with any microphone or instrument source, resulting in a beautifully rich and full sound from all sonic sources, i.e. from condenser to ribbon mics, to passive guitars. Each mic preamp also features switchable phantom, High Pass Filter and polarity reverse. The optical compressor is configurable as a dual mono or linked stereo processor — perfect for tracking stereo keyboards or as an insert on the mix-buss. The classic three band Meequalizer is also on hand to provide superb tonal control. In addition to balanced mic and line inputs on the rear panel, there is also a specially optimized instrument input on the front of each channel for direct connection of an electric guitar or bass. Add the optional VC1QD digital output card and you can capture every nuance of the JOEMEEK sound to your digital workstation.



VC6Qcs British Channel

Hand made in England, the VC6Qcs is a single rack space channel strip designed to give you the best possible performance from any audio source whether tracking from a microphone or direct instrument input or during final mixdown. It combines the warmth and character of three legendary JOEMEEK components – the CurrentSense impedance matching mic pre amp, JOEMEEK photo optical compression, and 3-band Meequalizer. Individual bypass switches for the compressor and Meek-Q help you to lower the noise of recordings. The Dual 1/4" Superbal outputs provide separate recording and monitor outputs – ideal for latency-free computer based recording.

5-Stage Preamp

- ◆ Transformerless input stage and a low-noise input amplifier delivers high headroom
- ◆ 5-stage amplifier design, controlled by a single volume control, gives (microphone) input headroom of more than 30dB; the input is floating balanced and will easily accept mic levels from -80dB up to more than 0dB (100dB with the pad engaged)
- ◆ Current Sense mic preamp design significantly improves the performance of dynamic microphones
- ◆ Input Gain control provides headroom greater than 60dB line (30dB mic)
- ◆ Switchable +48v phantom, 20dB pad and phase reverse as well as a peak LED

JOEMEEK Compressor

- ◆ Legendary photo optical compressor provides classic warmth and punch
- ◆ Controls are provided for 'compression', threshold, fully variable slope (ratio).
- ◆ Compression ratio varies from 1.5 to 1 up to 7 to 1 depending on musical content and the setting of the 'slope' control
- ◆ Attack is variable from 0.5 to 5 ms. and the release from 250ms to 5 seconds
- ◆ A 5-segment gain reduction LED meter and In/Out switch with blue status LED

3-Band Meequalizer

- ◆ Meequalizer provides the smooth tones of vintage EQs – ideal for tracking or mixdown
- ◆ LF and HF shelf, plus parametric mid sweep each with ± 15 db boost/cut
- ◆ In/Out bypass switch and status indicator

Output Stage

- ◆ 9-segment LED smooth tracking LED input meter to helps you control signal levels
- ◆ Dual 1/4" TRS 'Superbal' outputs will also accept unbalanced outputs without any gain loss – one output can be used for recording while the other is available for monitoring

Additional Features

- ◆ Pre-compressor/EQ insert point allows you to add additional effects or processing in the signal chain
- ◆ Front panel 1/4" instrument input
- ◆ XLR mic and 1/4" line inputs on the rear panel
- ◆ Extended 10Hz to 25KHz frequency response (+0, -0.5dB) delivers clearly defined bass

JOEMEEK

VC8 FATHEAD

Instrument Head

The FATHEAD VC8 is a single channel front end for musicians and vocalists that combines JOEMEEK's acclaimed CurrentSense preamp design, opto-compressor and Meequalizer with a unique opto-distortion designed specifically for use with amplified instruments such as guitar and bass. Inputs are provided for a microphone or direct insertion of an instrument. Two "Superbal" outputs as well as a DI output with a gain control allows you to use the Fathead with a guitar amp, mixer and recorder (simultaneously if need be). The included Fathead Controller allows you to bypass the EQ, distortion and compressor as well as mute the outputs.



FEATURES

- ◆ 1/4" instrument input on the front panel as well as 1/4" line, XLR mic inputs on the rear panel.

CurrentSense Instrument/Mic Preamp

- ◆ The latest generation CurrentSense pre amplifier circuit gives ultimate flexibility and quality whether using line, mic, or instrument sources – equally at home as an on stage head unit, or in the studio as a pre amplifier for a mic or instrument
- ◆ Switchable +48V Phantom, 20dB pad and Phase reverse

Opto-Distortion

- ◆ Provides vintage analog distortion ranging from valve warmth through to relentless screaming fuzz
- ◆ Unique Optical Distortion feature, with in/out and optical drive
- ◆ In/Out bypass switch

Classic JoeMeek Optical Compressor

- ◆ 5 position preset switch with settings ranging from 'Warm Meek' for subtle warmth, to 'Super Joe'- for absolutely massive crunching compression
- ◆ Bypass control
- ◆ 4-segment LED gain reduction meter
- ◆ Threshold control
- ◆ Automatic gain compensation
- ◆ Signal sensitive ratio



3-Band 'Meequalizer'

- ◆ LF and Mid sweep, and high shelf controls optimized for instruments
- ◆ Highly interactive, overlapping LF and Mid sweep controls allow phasing and other classic effects, while always maintaining musicality – even at extreme settings

LF Range	150 to 1k Hz
LF Boost/Cut Range	±16dB
MF Range	1k to 5k Hz
MF Boost/Cut Range	±16dB
HF (fixed)	Centered at 8kHz
HF Boost/Cut Range	±14dB

Output Stage

- ◆ A 5 segment input LED meter shows the level of the signal before the output gain control
- ◆ Output gain knob controls the level of the main and optional digital outputs
- ◆ A silent operating Mute function, operated from the front panel and the foot switch, aids in instrument changes, and silent studio operation by cutting all sound from the main outputs, and DI output, while allowing audio to be passed the tuner output
- ◆ A 1/4" tuner output jack
- ◆ An 1/4" TRS insert jack allows you to add external effects processors

Outputs

- ◆ Dual floating balanced 1/4" TRS main amplifier outputs
- ◆ 1/4" DI output with pre/post switch and independent gain control
- ◆ Optional 24bit/96kHz digital output via the VC1QD module
- ◆ Ground lift switch
- ◆ Includes the Fathead Controller Footswitch with EQ, distortion, compressor and mute controls.

VC1QD - 24-bit / 96kHz Digital Output Option



- ◆ User installable 24bit Coaxial S/PDIF output switchable between 44.1/48, 88.2/96kHz sample rates
- ◆ Compatible with the VC1Qcs, TwinQcs and FatHead preamplifiers
- ◆ 115dB dynamic range

MC2 Stereo MicroMeek Compressor

The MicroMeek MC2 is a professional quality stereo compressor that gives you the full sound of the JOEMEEK photo optical compression circuit in an affordable package designed for the project studio. With only a few simple controls, the MC2 will allow you to add vintage warmth, sparkle and power to vocal tracks, instruments, subgroups – even entire mixes.



- ◆ Unparalleled build, design and sound quality gives project studios, and musicians access to the true sound of real photo optical compression at an affordable price
- ◆ Auto-variable slope (ratio) control allows a wide range of compression and limiting sounds to be achieved with effective ratios from 1.5:1 up to 14:1
- ◆ Variable input and output gain controls as well as variable attack, release controls
- ◆ DIC (Dynamic Image Control) utilizes M&S sum and difference encoding and decoding to achieve perfect stereo imaging and balance across its stereo optical compressor
- ◆ TTT (Transparent to Transients) optical circuit design allows transients through unharmed. This allows more aggressive compression without dulling the sound
- ◆ 9-segment LED gain meter and 5-segment LED compression metering
- ◆ Dual 'superbal' input and output stages provide and optimized signal path that minimizes common mode interference
- ◆ Although designed as a stereo compressor, the MC2 can also be used as a single channel mono compressor
- ◆ 1/4" TRS inputs and outputs accept both balanced and unbalanced signals

MQ3 MicroMeek with Current Sense Mic Preamp

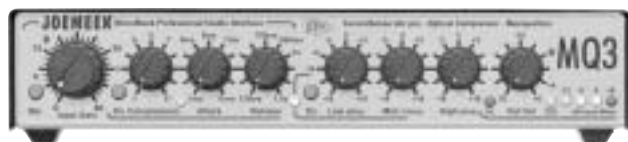

The MQ3 Pro Channel is a 1U half-rack channel strip that packs the sonic punch and features of its big brothers including the "Current Sense" microphone pre amplifier, the JOEMEEK compressor, the stunningly musical JOEMEEK Meequalizer "EQ" and gain make-up output volume control. Don't be

fooled by its small box — the MQ3 offers almost identical sounds and quality as JOEMEEK's more expensive preamps, with the ability to add warmth and thickness into the pure and clinical sounds of modern digital equipment, but at a fraction of the price. The Pro Channel truly delivers world class sound at an amazing price, and is a must for the user whose quality requirement is greater than their budget.

Mic Pre

- ◆ Current Sense auto-impedance matching mic preamp with a variable input level from -70dB to 0dB and switchable phantom power

The Compressor

- ◆ The compressor channel provides the same sonic capabilities as the VC1Qcs but is a little easier to use — a single rotary pot is used to control that compression amount as well as (auto ratio) compression ratio which varies from 1.5 to 1 up to 7 to 1 depending on musical content
- ◆ Attack and release controls are also available

The EQ

- ◆ The same 3-band VC5 "Meequalizer" channel as the VC1Qcs except for the Mid band which has a fixed frequency of 1.8kHz

Inputs

- ◆ XLR balanced microphone input, as well as a 1/4" TS jack suitable for any line or instrument level audio signal
- ◆ A 1/4" mix input (pre compressor) mixes with the normal mic or line inputs. It can be used to add a second signal post EQ and pre compression
- ◆ A 1/4" TRS insert point located after the mic amp and pre compressor allows you to add an external processor

Outputs

- ◆ Dual balanced low impedance 1/4" TRS line level outputs, connected in parallel, can be used simultaneously as a recording output while the other is used for monitoring/PA.

Metering

- ◆ A five stage LED meter indicates power on and output levels from -12dB to +8dB
- ◆ A red overload LED (post EQ) indicates that a signal is within 6dB of overload

Additional Features

- ◆ External power supply
- ◆ 1RU 1/2 rack aluminum case

LEXICON

MPX-110

24-Bit Dual Channel Processor

The MPX 110 is a true stereo dual-channel processor with 24-bit internal processing and S/PDIF digital output.



Utilizing Lexicon's proprietary

Lexichip, the MPX-110 offers 240 factory presets, 16 user-definable presets, plus Lexicon classic true stereo reverb programs such as Ambience, Plate, Chamber and Inverse as well as Tremolo, Rotary, Chorus, Flange, Pitch, Detune, Delay and Echo. Dual channel processing allows control of completely independent effects on the left and right channels.

Powerful and affordable, the MPX-110 offers the critically acclaimed Lexicon sound to a wide range of users from performing and recording musicians to professional studios and desktop developers

FEATURES

General

- ◆ Proprietary Lexichip engine provides independent dual channel effects including true stereo reverb programs such as Ambience, Plate, Chamber and Inverse as well as Tremolo, Rotary, Chorus, Flange, Pitch, Detune and 5.7 seconds of Delay and Echo
- ◆ 24-bit A-to-D and D-to-A conversion as well as 24-bit internal processing
- ◆ 20Hz – 20kHz ± 1 dB frequency response
- ◆ 19" rackmountable (1RU high)

Presets

- ◆ 240 factory presets and 16 user-definable presets are easily accessible using the Program and Variation Knobs—the Program knob selects among Single, Dual, and User programs while the Variation knob selects one of 16 variations for the selected program
- ◆ The 240 carefully-crafted presets feature legendary Lexicon reverb, as well as dual programs that combine two independent effects in four routing configurations
- ◆ Dual Programs – Combine two independent effects in four routing configurations:
 - Dual-channel processing allows you to combine Delay and Reverb algorithms, or either algorithm with a Flange, Pitch, or Chorus algorithm
 - Dual programs are available in four routing configurations: Dual Stereo (Parallel), Cascade, Mono Split, and Dual Mono

Easy Front Panel Operation

- ◆ Dedicated Input, wet/dry Mix and Output level controls
- ◆ The Adjust knob controls the most critical parameters for each preset – for some presets, the Adjust knob is patched to multiple parameters to provide simultaneous control of related effects
- ◆ The Effects Lvl/Bal knob allows you to control the effect level of Single programs or the balance of effects in Dual programs
- ◆ Dual, 2-stage LED headroom indicators

Tap Tempo

- ◆ Tap Tempo simplifies the process of matching the delay times and modulation rates of tempo-based presets with your music – Whenever a tempo-based preset is loaded, the Tap button LED flashes, press the Tap button twice in time with the music and the appropriate delay time will be automatically calculated
- ◆ Tempo can also be set using audio input (a must for live performances), a dual footswitch, or an external MIDI device that uses Continuous Controller or Program Change messages
- ◆ Tempo-controlled delays lock to Tap or MIDI Clock
- ◆ Tap tempos can be controlled by audio input, the front panel Tap button, dual footswitch, external MIDI controller or MIDI Program Change

MIDI Control

- ◆ Full MIDI control is provided via a powerful editing tool called Learn Mode that allows patching of five front panel controls to a MIDI Continuous Controller value.
- ◆ You can use MIDI CC or Program Change messages to manipulate the Adjust, Effects Lvl/Bal, and Mix knobs, as well as the Bypass and Tap buttons as well as use Program Change messages to load programs
- ◆ Non-learnable MIDI patches can also be recognized providing access to audio parameters that are not available from the front panel
- ◆ Controls can be automated and recorded into a sequencer allowing complete preset automation

Inputs and Outputs

- ◆ Left (mono) and Right unbalanced 1/4" analog inputs accept direct instrument input
- ◆ Left and Right unbalanced 1/4" analog outputs – the left output can be used as a mono out while the Right output can be used to feed a pair of stereo headphones
- ◆ The coaxial S/PDIF output has a 44.1kHz sample rate – it is always active so it can be used simultaneously with the analog outs and can be set to wet or dry for use as a high-quality stand-alone A-D converter
- ◆ A 1/4" T.R.S. footswitch connector is provided for remote bypass and tap operation

MPX-200

24-Bit Dual Channel Processor



Legendary Effects

- ◆ Plate, Gate, Hall, Chamber, and Room – Legendary Lexicon programs recreate the acoustics of reverberant spaces
- ◆ Ambience – world-class programs available for room sounds without reverberation
- ◆ Tremolo – offers classic shapes such as square, sawtooth, triangle, sine, and rectified sine. The Adjust knob changes the synchronization of the left and right sweeps to produce mono or stereo effects, and the Tap button matches the tremolo rate of the program with the tempo of the music.
- ◆ Rotary – programs simulate a Leslie-style cabinet. Like the physical model, the high (horn) and low (drum) frequencies are separated and “spun” in opposite directions. Horn and drum speeds are independent, designed with the acceleration and deceleration characteristics that simulate the inertia of the original mechanical elements.
- ◆ Chorus – inherited from the award-winning PCM Series, pans six independently-randomized delay voices across the stereo field to create a rich, airy effect that multiplies a single source into several
- ◆ Flange – programs feature two 2-tap delays, one per channel. Mixing the two tap delays together creates characteristic flange effects such as swishing, tunneling, and fading
- ◆ Pitch – programs shift monophonic sources within a range of one octave up to two octaves down
- ◆ Detune – programs with one pair of voices per channel, one sharp and one flat. These voices add a delayed or pitch-shifted version of the source to thicken the sound, creating a particularly effective simulation of double-tracking
- ◆ Delay and Echo – programs include mono (5.5 sec.), stereo (2.7 sec.), and 6-voice multi-tap effects, each of which can be used to create tape echo or digital delay effects.

Lexicon introduced the first digital audio processor in 1971 and followed with the first commercially successful digital reverberation unit for professional audio studios in 1979. Presently, the “Lexicon sound” is heard on more than 80% of the world’s most successful music albums and theatrical soundtracks.

The MPX-200 combines the best of the MPX 110 with an expanded set of control capabilities to provide deeper editing possibilities. The MPX-200 features the same independent 24-bit dual channel processing, 240 presets, Tap Tempo and MIDI Learn functions as the MPX-110, but also offers a digital compressor algorithm that is available in all 240 programs, including the dual programs. This allows you to have two effects plus a compressor running simultaneously. It also includes 64 User locations for storing variations of presets, coaxial S/PDIF digital I/O, three stage input level metering, and a universal power supply. The combination of Lexicon reverb and effects, ease of use, and flexible routing capabilities, makes the MPX-200 ideal for a broad range of users including project studios, desktop audio/sound designers, performing musicians and professional recording studios.

SAME FEATURES AS THE MPX110 PLUS—

General

- ◆ 240 carefully crafted factory programs plus a bigger User bank with 64 locations to store individual variations of these programs
- ◆ Coaxial S/PDIF digital inputs and outputs

Front Panel

- ◆ Front panel controls include input level, program load, program edit, compressor, multi-function adjust, bypass, tempo tap.
- ◆ The Adjust knob not only allows instant manipulation of the critical parameters of each preset, it is also used for selecting, editing, and cueing programs as well.
- ◆ Up to eight adjustable parameters are available in each program
- ◆ Adjustable parameters for each program include: Mix, Adjust, EQ and Level/Balance

Display

- ◆ Easy to read LED displays indicate current Effects and Routing, Edit Parameters, program Load, MIDI, Store and tempo Tap
- ◆ 3-stage headroom indicators are provided for the left and right channels
- ◆ A 4-stage compressor gain reduction indicator is also provided

Digital Compressor

- ◆ Independent control over Ratio, Threshold, Attack and Release are provided
- ◆ The compressor can be used to subtly reduce volume changes and to increase the volume of low level signals — at more extreme settings the compressor acts as a limiter that prevent the volume from exceeding a certain level
- ◆ The compressor is available in any program and is situated in front of any other effects in the wet component signal path – it has no effect on the dry signal coming out of the Mix control or the Bypass signal when Bypass Mode is set to dry.

Conveniences

- ◆ Assignable bypass mode allows push button or footswitch selection of dry or muted audio output
- ◆ Cue Program Mode allows you to jump from one program to another – simply set the adjust knob to the desired program and hit load at the appropriate time— ideal for live performance or mixing in the studio
- ◆ Built in power supply, switchable between 120/240 volts AC, 50 - 60Hz.

LEXICON

MPX-550

PROCESSORS

284

24-Bit Dual Channel Processor

The MPX-550 offers the same true stereo, dual channel processing found in the MPX-110 and MPX-200 plus adds a host of professional features including balanced analog I/O, sixteen adjustable

parameters per preset and four realtime control knobs not to mention the unmistakable Lexicon sound - all at an affordable price. The unit's deeper editing capabilities are aided visually by a 150 x 32 backlit LCD display with adjustable contrast. The MPX-550 also features an additional bank of 25 presets dedicated to compression effects. For users craving that authentic Lexicon sound along with the need to have detailed control over a sounds color and shape, the MPX-550 delivers.



SAME FEATURES AS THE MPX200 PLUS—

General

- ◆ 255 presets and 64 user presets including a bank named Compressor which features dedicated presets for compressor—only as and combination compressor/reverb presets with parallel (dual stereo) routing
- ◆ 24-bit 44.1kHz and 48kHz operation

Enhanced Digital Compressor

- ◆ Dedicated stereo compressor acts on both L and R channels simultaneously and uses the sum of the two channels as its trigger
- ◆ Use as a single-channel compressor with side-chain trigger by feeding one channel a level that is at least 6 dB hotter than the other, thus making that channel's signal dominate the compressor's performance
- ◆ Gain reduction is indicated by a descending bar between the two input level meters
- ◆ The Compressor/Reverb presets are constructed to give the user both a reverb component and a zero-delay "dry" component, with the compressor acting on both

Enhanced Tap Tempo

- ◆ The Tap button responds to consecutive presses instead of every other press - this allows end users to more accurately tap in tempos for delay, echo, etc...

Graphics Display

- ◆ 150 x 32 backlit LCD display gives you program and system status at a glance, or easy access to the edit pages in each program

Easy Front Panel Operation

- ◆ The Program Select knob allows you to scroll through stored programs, and jump between banks for fast and easy selection
- ◆ Each program has up to 16 adjustable parameters, organized into "edit pages" consisting of as many as four parameters each - the Edit button cycles through all available pages for the current program
- ◆ Four dedicated edit knobs corresponding to displayed parameters make editing easy

Conveniences

- ◆ Auto-switching power supply, 90-250v AC, 50/60Hz
- ◆ Switchable Locked Mode is available to load only specialized User programs—ideal for live sound and fixed installations

Inputs And Outputs

- ◆ Balanced XLR and 1/4" analog inputs/outputs as well as coaxial S/PDIF digital I/O

MPX-R1

MIDI Remote Controller for the MPX-550 and MPX-1

With the MPX-550 or MPX-1 in the effects loop of your stage rig and an MPX-R1 on the floor, you're ready to take your favorite

studio effects on the road. A single cable provides power and two-way communication with the processors.



- ◆ Dedicated stomp-box style buttons and LEDs give you complete access to the entire arsenal of MPX-550/MPX-1 effects
- ◆ Programmable expression pedal with toe switch
- ◆ MIDI program select and control
- ◆ Dedicated footswitches for TAP tempo and A/B switching
- ◆ All-metal chassis, pedal and switches



EQUIPMENT LEASING AVAILABLE

Multi-Effects Processor

The MPX-1 represents the benchmark of high-quality audio effects, interactive control, intuitive operation and affordability. The MPX-1 combines

Lexicon's proprietary LexiChip dedicated to uncompromised stereo reverb algorithms, with a second 32-bit DSP that provides up to

4 of additional effects – each with a true stereo audio path. A large library of factory programs, based on 56 algorithms, provide a versatile array of sounds designed for a wide variety of performance, sound design and production applications. The MPX-1 also features in-depth editing of every parameter and complete flexibility of routing and effect order in every program allowing you to take your sound as far as you want to go quickly and creatively.



FEATURES

General

- ◆ 200 preset programs designed for a wide variety of audio sources and applications plus 50 user-definable presets.
- ◆ A built-in DataBase function makes it easy to find the program that best suits your needs – and because the database is completely user-definable, you can reorganize all 250 programs any way you want.

Two Separate DSP Processors

- ◆ Combines Lexicon's proprietary Lexichip dedicated to delivering uncompromised Lexicon stereo reverb or ambience with a separate, fast-math DSP processor that provides up to 4 additional stereo effects.

Instant Access

- ◆ Six effect types, based around 56 effects algorithms, are accessible via back-lit buttons on the front panel including 32-bit parametric EQ, Pitch, Chorus, EQ, Modulation, Delay (including looping and ducking) and world-class reverb effects.
- ◆ Up to 5 independent stereo effects are available simultaneously and are routable in any configuration, with individual mix and gain for each effect.
- ◆ Effects can be placed in any order by dragging and dropping them on a visual map.
- ◆ Dedicated Mix and Patch buttons give you instant access to mix and level settings of any or all effects, and the patch system.

Interactive Front Panel

- ◆ A numeric display makes program and patch numbers highly visible while an alphanumeric display shows program, parameter and routing values.
- ◆ Bypass button lets you toggle master bypass
- ◆ An A/B glide button lets you morph between effects or parameter variations.

Tempo Control

- ◆ A Tempo LED flashes at the current tempo in any program that utilizes delay times or modulation rates – a Tap button lets you change tempo on-the-fly.
- ◆ Tempo parameters will synchronize to incoming MIDI clock and MIDI clock can also be transmit based on Tap tempo.

Editing

- ◆ "Soft row" mode offers direct access to the most useful parameters of any program – so you can fine-tune any preset without having to enter a separate Edit mode.
- ◆ When you want to completely restructure a program, or create a new one from scratch, the Edit mode lets you dive as deeply as you want into an extensive array of effect and program parameters.

MIDI Functionality

- ◆ In addition to separate OUT and THRU connectors, the MPX 1 supports remote power with a 7-pin DIN connector.

Built-in MIDI Arpeggiator

- ◆ MIDI arpeggiator processes held notes received from an external sound module to the MIDI in and transmits them as arpeggios through MIDI out. There are two presets, as well as a full range of parameters for building an arpeggio from scratch.

Patch System

- ◆ The Patch System provides more than 150 internal and standard MIDI controllers that can be assigned to modulate any effect parameter – up to 5 patches are available per program.
- ◆ Internal controllers include: two LFOs, two ADRs, two Envelope Followers, Random Generator, Arpeggiator, A/B Glide (morph), Tempo and Sample and Hold Generator.
- ◆ MIDI Learn feature lets the MPX 1 recognize a MIDI control as a patch source.

Audio Connections

- ◆ Balanced XLR and 1/4" TRS analog inputs and outputs
- ◆ -10dB to +4dB switchable levels
- ◆ 24-bit coaxial S/PDIF digital I/O

Footswitch/Footpedal

- ◆ A 1/4" TRS input connector will accept three simultaneous footswitches
- ◆ Another 1/4" TRS connector is provided for a footpedal

LEXICON

PCM-81

Digital Effects Processor



The PCM 81 is Lexicon's top of the line, single rack space Digital Effects Processor. It has everything that top recording studios require in a multi-effects processor and more. Lexicon's unique Dual-DSP Platform enables the PCM 81 to create the most flexible effects combined with superb reverberation based on the legendary Lexicon 224, PCM60 and PCM 70 processors. The PCM 81 exhibits extraordinary sonic clarity with 24-bit internal processing, 24-bit A-to-D and D-to-A converters, balanced XLR and 1/4" inputs and outputs as well as 24-bit AES/EBU and S/PDIF digital I/O. An enormous selection of sounds are 300 factory presets are on-hand based on 17 algorithms that combine an uncompromising stereo reverb or ambience effect with a multi-voice effect. Two modes of editing gives you a choice of quickly grabbing a programs most pertinent parameters or diving way down deep where you can build your own presets from the ground up. Dynamic Patching makes it possible to route any of 150 sources to any parameter delivering a truly unique set of capabilities, from realtime and tempo-based modulating of sounds, to producing unusual and ethereal spaces, to altering the attack and decay characteristics of the sounds.

FEATURES

Presets

- ◆ A library of 300 carefully crafted factory presets (plus 50 user-definable presets) range from lush and beautiful to completely over the top and cover a wide variety of applications from performance, recording and remixing, to effects designed specifically for sound design, foley and video post
- ◆ Each preset gives you instant access to Pitch, Reverb, Ambience, sophisticated Modulators, over 21 seconds of Delay time as well as Dynamic Spatialization effects for 2-channel or surround applications
- ◆ There are a total of 17 algorithms separated into three general classes: 4-Voice, 6-Voice and Pitch – each includes an uncompromised stereo reverb effect, along with several voices of additional stereo effects.
- ◆ 4-Voice algorithms combine a specific type of reverberation with a 4-voice, general purpose, stereo effect "toolbox", as well as additional post-processing for the reverb.
- ◆ 6-Voice algorithms combine a specific type of reverb with a specialized 6-voice stereo effect.
- ◆ Pitch algorithms offer a unique type of pitch shifting, combined with an uncompromised Lexicon reverb.

Pitch Correct

- ◆ Pitch Correct provides a simple yet powerful set of tools for correcting off-pitch melody tracks within a range of up to three octaves (up or down). The Pitch Detect display shows the pitch of the input source in real time in chromatic note and +/- cents. The Correction parameter can be patched to a switch or the ADJUST knob, or even to a MIDI keyboard.

3-D Dynamic Spatialization

- ◆ These effects utilize two independent spatial processors that allow you to place effects virtually anywhere between, or even beyond, your loudspeakers
- ◆ By dynamically controlling spatial effects, you can create different spaces that change along with the music – For example, when playing sustained chords through Steered Rear, the PCM 81 automatically steers the reverb around you (into full rear in surround sound) when the input audio decays past the threshold.

The Interface

- ◆ The large, 2-line fluorescent display is easy to see from any angle whether the surroundings are bright or dark
- ◆ The ubiquitous Lexicon Adjust knob is on-hand for controlling a programs most critical parameters
- ◆ A special Info mode allows you to press and hold any button to find out what its function is, or to get status information such as the name of the running effect, current tempo rate, etc.

Pro and Go Edit Modes

- ◆ In Go mode, up to 10 of the most useful parameters within an effect are grouped for instant access via the front panel Edit button – Each preset has a selected set of Go mode parameters which let you make value changes to the effect without losing the original identity of the sound.
- ◆ Pro mode gives you access to the full parameter editing matrix (as many as 100) for the algorithm of any loaded effect. In this mode, you can access a complete set of Modulation and Patching parameters, create your own ADJUST knob patch and assign your own Go mode parameters.

Dynamic Patching Matrix

- ◆ Dynamic Patching allows you to map data from any of 143 possible control sources to any effect parameter (destination)
- ◆ Up to 10 patches can be created per effect, each with as many as 8 pivot points allowing very complex and mind-altering modulation paths
- ◆ You can patch multiple parameters to a single controller, or patch multiple sources to a single destination
- ◆ There are three types of Sources available:
 - ◆ Internal controllers include Tempo (both internal Tap and external MIDI clock), LFO (Sine, Cosine, Square, Triangle, Pulse, Sawtooth), Time Switches, Latch, AR Generator, and Left & Right Envelope Followers
 - ◆ MIDI modulators such as Pitch Bend, Velocity and After Touch
 - ◆ Or any of 126 MIDI Controllers as well as external sources such as footswitches and footpedals

Tempo Control

- ◆ The Tap tempo control offers the ability to create independent rhythmic values per parameter within the same program based on note values or absolute time.
- ◆ Tempo can also be 'dialed-in' so you can set the tempo in exact beats-per-minute.
- ◆ You can generate MIDI clock from your tap, as well as receive MIDI tempo from an external sequencer or drum machine.
- ◆ Tempo control LFO speeds and Time Switch controls. Thus all of your modulations can be synchronized with your music.

Conveniences

- ◆ The PCMCIA card slot accepts RAM cards that can be used to store as many as 2350 of your own programs on a 1 Meg card.
- ◆ The Compare button allows you to compare the active version of the current effect with the most recently stored version.
- ◆ The Bypass switch can be used to mute the audio output or bypass an effect depending on the setting of each program's bypass parameter.
- ◆ Standard 3-pin IEC power connector with 100-240V, 50-60Hz automatic switching power supply to correct voltage range.

Inputs & Outputs

- ◆ Balanced XLR-1/4" combo connector inputs and separate balanced XLR and 1/4" outputs
- ◆ Full AES/EBU (XLR) and coaxial S/PDIF digital I/O – the AES/EBU and S/PDIF outputs can be used simultaneously
- ◆ Analog and digital inputs can be mixed together
- ◆ MIDI In/Out/Thru connectors – all parameters, programs and registers can be accessed by MIDI.
- ◆ The 1/4" footswitch input can accept two momentary switches
- ◆ The 1/4" footpedal input can be used for realtime control of selected parameters.

Effects

- ◆ Fans of classic Lexicon sounds will appreciate updated versions of effects from the legendary PCM 70, like Tiled Room and Concert Hall.
- ◆ A wide variety of phone and microphone presets for Sound Design, Surround delays for film, Orchestral Reverbs, Complex EQ, Special FX and Cyber FX
- ◆ Presets set up for delays that automatically lock to incoming MIDI clock
- ◆ Presets optimized for Keyboards, Guitar, Drums, Vocals and Orchestral instruments.
- ◆ Pitch Shifting algorithms include doubling, quadruple-tracking, chorus, as well as pitch correction
- ◆ Pitch Correct provides a simple yet powerful set of tools for correcting out of tune melody tracks within a range of up to three octaves (up or down). The Pitch Detect display shows the pitch of the input source in real time in chromatic note and ± cents. The Correction parameter can be patched to a switch or the ADJUST knob, or even to a MIDI keyboard.

OPTIONAL PCMCIA FX CARDS

Dual FX Algorithm Card

- ◆ 25 additional algorithms and 250 additional presets.
- ◆ Built-in Submixer for completely separate control of inputs, outputs, and routing of reverbs and effects. Allows seamless, continuous and dynamic transition between Serial and Parallel effects routing (controllable by the Adjust Knob, footpedal or MIDI)
- ◆ Processed Reverb- extensive tailoring of the effects with presets designed for several applications: Drums, Vocals, Guitars, and other music related needs.
- ◆ Analog Sound Modeling Presets: two-track tape echo & rolloff, tape flanging, room mic placement and other "Classic Effects".

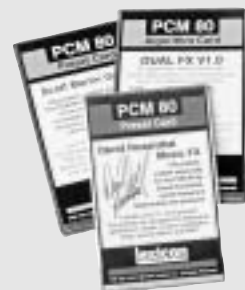

Post FX Preset Card

- ◆ Offers 100 presets by Scott Martin Gershin (Hollywood's top Sound Effect Designer) for post-production and sound design for film and video applications.
- ◆ Featuring spectacular presets designed to create special effects from simple impulse inputs.
- ◆ Wide variety of phone and microphone fuztes and presets for sound design, surround delays for film, orchestral reverbs, complex EQ, special FX and cyber FX.

Music FX Preset Card

- ◆ 100 powerful Presets for a wide variety of musical applications designed by David Rosenthal (keyboardist for Billy Joel's River of Dreams Tour).
- ◆ Includes delays that automatically lock to incoming MIDI clock, presets optimized for keyboards, guitar, drums vocals and orchestral instruments as well as performance and stage applications utilizing MIDI and Dynamic controllers for expressiveness.

LEXICON

PCM-91

Digital Reverberator



The PCM 91 Digital Reverberator offers Lexicon's highest quality reverbs in a compact, affordable package with a powerful interface that allows easy access to the plethora of powerful programming capabilities. It combines the same user-interface, editing, dynamic patching and I/O capabilities of the PCM 81 with a unique dual-processor architecture that features two of Lexicon's proprietary reverb DSP ICs, the Lexichip, designed to deliver exceptional reverb quality along with unprecedented flexibility and control. The PCM 91 offers 450 reverberation programs, each of which has been designed specifically with real-world music production, live performance, sound design and video post-production applications in mind. All of the features of the critically acclaimed PCM 90 are included, plus onboard Dual Reverb algorithms and presets with dynamic spatialization effects for 2-channel or surround sound applications. Unique to the PCM 91 is the implementation of four custom controllers that act as four additional Adjust knobs capable of accessing a programs most critical parameters. The onboard Keyword search allows you to find appropriate programs by application.

FEATURES

Reverb Realism

- ◆ Built-in library of 450 factory presets and 100 User preset locations containing Lexicon's highest quality reverb effects that simulate realistic halls, rooms and plates, and let you create completely natural, or other-worldly spaces
- ◆ Create incredibly realistic small spaces for music or film work - from the ambience of a phone booth to a very small drum room

15 Algorithms

- ◆ 5 stereo algorithms to create different types of reverb effects and 10 Dual Reverb algorithms which offer superb dual reverb and cascade configured stereo effects.
- ◆ Single algorithm include an uncompromised stereo reverb effect with selected "tools" for ambience, post-processing, compression/expansion, as well as modulation and patching parameters which are common to each algorithm
- ◆ Dual algorithms contain two independent reverb blocks, as well as the full set of modulation and patch features in the single effects

Four Custom Controllers

- ◆ These controllers are placed on the Soft Row and are a combination of one or more parameters patched together, each with their own individual scaling values. It's like having four additional Adjust Knob controls on the Soft Row.

Intelligent Interface

- ◆ The KeyWord Search function allows you to find a group of programs designed for a given application - for example if you choose the Live PA KeyWord, the PCM 91 will automatically locate all the presets that have been optimized for that application. There are 50 keywords in all, including four user-definable groups of effects.
- ◆ The History Of Effects Loaded feature allows you to review the last ten effects loaded - useful for when you want to return to an effect you were using earlier, but can't remember its name or location.
- ◆ If you want to know more about the function of a particular button (without actually executing any action) press and hold the button down and message with an explanation will appear on the display.

Same As The PCM81

- ◆ The Adjust knob allows realtime control of a presets most important parameters without ever going into the Edit mode.
- ◆ Pro and Go editing modes offer you the choice between easy access to a programs most important parameters or full access to all of a programs parameters and build an effect from its basic algorithm up
- ◆ Dynamic Patching provides an expressive means of modulating sounds as well as the ability to alter the attack and decay characteristics of the sound.
- ◆ Tap Tempo with independent rhythmic variations or dial in tempos in BPM.
- ◆ Dynamic Spatialization with two independent spatial processors that allow you to place effects virtually anywhere between your loudspeakers - or even beyond them.
- ◆ PCMCIA Card Slot for user-edited preset and system set up storage.
- ◆ Balanced XLR-1/4" combo connector inputs and balanced XLR and 1/4" outs.
- ◆ Full AES/EBU (XLR) and coaxial S/PDIF digital I/O
- ◆ 1/4" footswitch and foot controller inputs

Guitar Effects Processor

The MPX G2 is a hybrid Guitar Effects Processor that combines the highest quality 32-bit digital effects with analog distortion



and overdrive as well as dedicated analog tone controls and an analog Speaker Simulator. The MPX G2 will work with any amp, allowing the guitarist to place authentic effects anywhere in the signal chain, without altering the amp's basic tone. For direct recording or PA applications, the MPX G2 can be used without an amplifier as a stand-alone programmable analog preamp with effects. Two separate signal paths allows effects such as compression, wah and analog overdrive to be placed in front of the amp, while other effects like delay, chorus and reverb can be placed in the amp's effects loop. The MPX G2's effects include several authentic recreations of vintage stomp boxes such as Tube Screamer, Mu-tron III, Cry Baby, Dyna Comp and Space Echo, to name a few, and studio effects like JamMan, Intelligent Pitch Shifting, Tap Delay, Chorus, Flange, Rotary Speaker, Parametric EQ and Lexicon Reverb and Ambience. Lexicon's optional MPX R1 MIDI Remote Control pedal board provides enhanced hands-off control of all the MPX G2 features, and creates a powerful, versatile system with two programmable relays to switch up to four amplifier channels and control up to seven effects at once.

FEATURES

- ◆ Two separate audio paths let you place effects in front of your amp or in the amp's effects loop.
- ◆ Use without an amp as a stand-alone pre-amp with effects.
- ◆ All of the hardware of a custom guitar rig is built-in: a loop switcher with analog relay bypass, an effects router, analog and digital noise gates, chromatic tuner and an analog speaker simulator.
- ◆ Dynamic Gain, Lexicon's analog distortion technology, provides screaming overdrive and warm distortion tones which can be used as an analog stomp box in front of your amp, or as a standalone preamp for direct recording or live performance.
- ◆ Effects can be synchronized with the music by assigning tempo control to modulation rates, delay times or any effect parameter. Tempos can be tapped with the Tap button (or an assigned controller) or dialed in. MIDI clock can be generated from your tempo, or you can receive MIDI clock from an external sequencer or drum machine.

Inputs and Outputs

- ◆ 1/4" guitar inputs are available on both the front and rear panels.
- ◆ 1/4" and XLR left and right outputs
- ◆ 1/4" effects send and 1/4" left and right effects returns.
- ◆ 1/4" stereo headphone output

Effects

- ◆ There are 76 effects organized into seven types. Any active effect can be accessed or bypassed just by pressing the front panel button.
- ◆ Effects can be placed in any order, simply by "dragging and dropping" them on a simple visual map.
- ◆ Gain and amp effects include Tone controls, Overdrive, Screamer and Distortion effects, along with a fully featured, programmable analog guitar preamp.
- ◆ Effect 1 and 2 contain Pitch Shift, Detune and Tremolo effects, Panners, Phasers, Compressors, and an assortment of wah and volume controls including recreations of classics like the Uni-Vibe, Dyna-Comp, Phase 90, Vox and Cry Baby wah.
- ◆ Chorus effects include classic chorus and flanger effects along with rotary speakers, and spatial panning effects.
- ◆ Delay effects include delay, echo, and ducking effects as well as a JamMan style looper with 20-second full-bandwidth delays.
- ◆ Reverb effects include a full complement of Lexicon's classic true stereo reverberation and ambience effects. Dedicated processing resources are allocated to the reverb effects to ensure that you are always able to load an uncompromised reverb into any program, regardless of what other effects are loaded.

Presets

- ◆ The large 300 preset library is organized with a database that allows you to quickly search for programs based on their styles like Rock or Blues, by the type of effects such as OverDrive, or to find only programs suitable for stand alone operation.

Editing

- ◆ A front panel Soft Row button takes you directly to the most useful parameters of each program.
- ◆ Front panel System and Edit buttons give you access to all of the controls you need to completely reconfigure your system or to create completely new programs.
- ◆ The A/B glide function allows you to glide from one program to another with a single button push.

Patching System

- ◆ The MPX G2 patch system provides an assortment of controllers that can be assigned to any effect parameter (up to five per program). These controllers include LFOs, A/B Glide and Tempo.
- ◆ MIDI In, Out and Thru connectors allow you to control of A/B and Tap tempo, MIDI clock, as well as all effect parameters.
- ◆ Connecting an MPX R1 gives you stomp box control of all of the MPX G2 effects.

PRESONUS

M80

PROCESSORS

290

Eight Channel Mic Preamp with Mix Bus

The M80 provides eight channels of discrete Class A microphone/instrument preamplification with low noise, balanced input transformers along with several unique features. An ultra low impedance mix bus is available for assigning and panning any of the 8 channels to a pair of stereo outputs. A high gain headphone output for monitoring the bus. Another unique feature is the vintage warmth control provided on each channel that emulates the effect of analog tape saturation and vacuum tubes. Each channel is equipped with balanced XLR / 1/4" TRS mic/line inputs via Neutrik combo connectors and XLR balanced outputs. Separate 1/4" TRS send and return jacks are also on hand for inserting outboard dynamics processors.



Each Channel Features

- ◆ A discrete Class A input buffer followed by a twin servo gain stage provides ultra low noise and wide gain control allowing you to boost signal without increasing unwanted background noise
- ◆ Gain control provides 60dB of gain — the amplifier has inherent gain of 12dB thus delivering a total possible gain of 72dB



- ◆ +28 dBu of headroom provides a very wide dynamic range and excellent transient response
- ◆ Switchable 48v phantom power, phase (polarity) reverse, 20dB pad and a 6dB/oct low-cut filter at 80Hz
- ◆ Phantom power is supplied at a constant rate whether on one or all eight channels, ensuring condenser mics will be free of distortion associated with insufficient power
- ◆ Full Scale 7-segment LED metering (-36 dBu to +18dBu) plus a clip indicator

Inputs and Outputs

- ◆ XLR / 1/4" TRS Neutrik combo connectors accept inputs signals from mics or instruments
- ◆ XLR-balanced direct outputs will feed directly into the inputs of digital workstations as well as tape and disk-based multitrack recorders

Vintage Warmth Control

- ◆ The IDSS knob on each channel lets you add "warmth", much like a vacuum tube or analog tape saturation, to the audio source by boosting the even harmonic series of the input signal

Stereo Mix Bus (8X2 Mixer)

- ◆ A stereo mix bus allows you to combine the input signals of each channel for monitoring or live remote/straight to 2 track recording
- ◆ Each channel features a L/R Mix Bus assign switch and a pan knob for placing each signal within the stereo spectrum
- ◆ A high output stereo headphone output with level control on the front panel enables you to monitor the Mix bus in loud or ambient environments such as concert halls, clubs or in control rooms monitoring at high volume levels
- ◆ XLR mix outputs connectors accommodate both balanced and unbalanced signals
- ◆ The output level control has a range of -72dBu to +10dBu

Metering

- ◆ Servo balanced send/return jacks for inserting your favorite outboard gear

Additional Features

- ◆ An Auxiliary Input lets you daisy chain several M-80s together allowing them to share the last stereo output in the chain
- ◆ Housed in a 2RU, steel chassis with a high quality blue anodized front panel
- ◆ An external power supply ensure a noise free preamp environment.

System Performance

Dynamic Range	>120dB
Headroom	+28dBu
Noise Floor @ Bus	-90.2dBu
Noise Floor @ Main Output	-96.4dBu
Noise Floor @ Channel Output (+24dB Gain)	-88.2dBu
THD + Noise (no idss)	0.0024%
THD + Noise (max idss)	0.035%
THD + Noise	<0.02%
Frequency Response	10Hz to 60kHz ±0.5dB
Crosstalk	>82dB @ 10kHz

Input Specs	Impedance
XLR MIC / 1/4" TRS Line	10k Ω

Insert Specs	Impedance
1/4" TRS Send	51 Ω
1/4" TRS Return	10k Ω

Output Specs	Impedance
XLR	51 Ω



ONE HOUR FREE PARKING

AT 349 W. 34th STREET (with purchase of \$100 or more)

PRESONUS

DigiMAX & DigiMAX LT

Eight Channel Mic Preamps with 24-Bit Digital Output

The DigiMAX LT and the DigiMAX each combine eight channels of the same pristine, discrete Class A dual servo mic preamps as the M-80, MP-20 and VXP along with eight channels of 24-bit ADAT LightPipe digital outputs, to deliver the ideal front-end solutions for DAW's or for

adding mic pre's to digital mixers and sound cards. The DigiMAX LT features balanced XLR, 1/4" mic/line inputs with inserts on every channel while the DigiMAX provides eight XLR balanced mic inputs with direct 1/4" TRS analog outputs as well as Hi-Z instrument inputs on channels one and two that allow direct connection of an electric guitar or bass. The DigiMAX also features an EQ Enhance and a transparent dual domain limiter on each channel as well as a choice of four stereo pairs of coaxial S/PDIF or AES/EBU outputs via a 9-pin d-sub connector. Both units are housed in rugged 1RU chassis with a sturdy front panel milled from 1/4" solid aluminum and blue anodized aluminum knobs.



THEY BOTH FEATURE

8 Dual Servo Mic Preamps

- ◆ Each channel contains a Class A discrete input buffer followed by a dual servo gain stage to provide ultra low noise, wide gain control and the ability to boost signal without increasing unwanted noise
- ◆ Switchable phantom power and a 20dB pad are provided for each channel

Inputs

- ◆ The DigiMAX LT features eight balanced mic/line inputs using Neutrik XLR / 1/4" TRS combo connectors
- ◆ The DigiMAX features eight XLR-balanced mic inputs and Hi-Z 1/4" instrument inputs on channels 1 and 2

8-Channel 24-bit ADAT Lightpipe Outputs

- ◆ A front panel switch lets you choose sample rates of 32, 44.1 and 48 kHz
- ◆ An external clock switch, also on the front panel, works in conjunction with the Word Clock I/O, ensuring proper synchronization, and allowing either unit to slave to incoming timecode or be the master clock source within a digital system

Power Supplies

- ◆ Linear internal power supply (DigiMAX LT); External, 1/3 rack space power supply (DigiMAX)

DigiMAX LT Only

- ◆ 1/4" TRS insert points, provided on each channel, allow you to access external dynamics processors and EQs. Or, you can use the insert as an analog output by using a 1/4" TS connector

DigiMAX Only

- ◆ A dual domain limiter, on each channel, detects RMS and peak levels to achieve instantaneous transparent limiting — the RMS stage acts like a high ratio compressor while the peak stage is used to prevent the input of the A/D converter from clipping
- ◆ A dual concentric rotary control on each channel adjusts the channel's gain (inner) as well as the threshold parameter of the dual domain limiter (outer)
- ◆ A phase (polarity) reverse switch is also provided on channels 1 and 2
- ◆ An EQ enhancement switch on each channel cuts 3dB of signal between 250Hz and 5kHz has a smoothing effect on mid-range heavy signals providing a flatter response characteristic
- ◆ 1/4" TRS analog outputs on each channel duplicate the signals sent to the digital outs allowing you to monitor channels with an analog mixer and avoid the latency issues often encountered with digital workstations
- ◆ A 9 pin connector is internally configurable to provide 4 stereo pairs of either AES/EBU or S/PDIF digital outputs

Preamp Controls	
Input Gain Control	+12dB to +38dB
Switches	Phantom power, 20dB pad
24-Bit Digital Outputs	
ADAT Lightpipe	8 channel optical
DIGIMAX LT ONLY	
Inputs	
Mic / Line	8 Balanced XLR / 1/4" TRS
Insert Points	(8) 1/4" TRS
Metering	
2 Stage Signal Present LED	-20 & -10 dBu
Clip LED	+22dBu
DIGIMAX ONLY	
Inputs	
Mic	8 Balanced XLR
1/4" Instrument	Channels 1 & 2
Polarity Reverse	Ch 1 & 2 only
EQ Enhance Switch	-3dB (250 to 5k Hz)
Dual Domain Limiter	
Threshold Range	0dB to 0ff
Metering	
Signal Present LED	-20dBu
Clip LED	+22dBu
Limiter LED	Limiter Active
Analog Outputs	(8) 1/4" TRS
S/PDIF (RCA) Outputs	4 stereo pairs*
AES/EBU (XLR) Outputs	4 stereo pairs**
<small>*requires DM006 optional breakout cable</small>	
<small>**requires DM007 optional breakout cable</small>	

System Performance

Headroom	+22dB
Analog Dynamic Range	>120dB
Noise Floor	-94dBu
THD + Noise (unweighted)	<0.009%
Frequency Response	20Hz-50kHz
Power Supply Rejection	>98dB

PRESONUS

VXP

Dual Servo Voice Processor/Channel Strip Mic Preamplifier

The VXP is a class A channel strip/voice processor featuring a single channel of the M80/MP20's discrete class A



microphone preamplifier with IDSS control, plus a preset compressor, expander, tunable de-esser, four-band semi parametric equalizer and separate brick wall peak limiter.

- ◆ Discrete class A input buffer followed by a dual servo gain stage
- ◆ +24dBu headroom provides a very wide dynamic range and excellent transient response
- ◆ Switchable 48V phantom power, phase (polarity) reverse 20dB pad
- ◆ XLR balanced inputs and outputs as well as 1/4" TRS bal / unbal outputs
- ◆ 1/4" TRS bal / unbal send and return jacks allow you to insert an external processor (post preamp /pre processor)
- ◆ Comprehensive LED metering is provided for each processing stage

Smart Compressor

- ◆ 16 pre-set compression curves offer varying degrees of compression ranging from light to heavy, designed especially for processing voice
- ◆ Easy-to-use preset parameters derived from pro audio engineers provide a wide variety of "studio tested and proven" settings uniquely suited for virtually any singing style or vocal application

Expander

- ◆ The downward expander uses a dual concentric control with an adjustable threshold and ratio to provide seamless noise reduction ridding the signal of unwanted background noise

De-Esser

- ◆ A variable de-esser control with a range of 800Hz to 8kHz removes unwanted sibilance while allowing the signal to remain completely natural
- ◆ The threshold control makes setting the de-esser extremely precise and fine-tuning a simple process

4 Band Semi-Parametric EQ

- ◆ Fixed low and high shelving bands as well as sweepable low and high mid controls to provide total tonal control of the audio
- ◆ Each of the four bands feature a boost/cut range of ± 12 dB
- ◆ The low frequency control is fixed at 100 HZ while the high frequency is tuned to 12kHz with a shelving contour that accentuates the naturalness vocal signals.
- ◆ The low mid-range band is sweepable from 90Hz to 700Hz and the high mid-range is sweepable from 450 to 5.8k Hz
- ◆ A switchable Q function for each of the mid band frequencies is selectable from .5 (wide) or by a factor of 2 (narrow)
- ◆ An 80Hz filter is also provided for eliminating low frequency noise

Master Section

- ◆ The peak limit circuit is a sonically transparent brick wall limiter with an adjustable threshold to control the point at which the output signal is not allowed to cross — ideal for recording to digital devices where signal overload is unacceptable
- ◆ An output level control, variable from -70 dB to +10 dB, allows gain make-up due to compression or decreasing the output signal after boosting frequencies in the EQ

Optional Digital Output Card

- ◆ Provides AES/EBU and SPDIF outputs as well as an auxiliary 1/4" TRS analog line input that allows two VXP's to share both sides of the A to D converter from one digital output card
- ◆ Selectable 96, 48 and 44.1 kHz sample rates
- ◆ Superior Crystal Semiconductor A to Ds
- ◆ Psycho-acoustic dithering is provided to improve BIT resolution characteristics

Preamp Controls	
Input Gain Control	+12dB to +38dB
Switches	Phantom power, phase reverse, 20dB pad
Smart Compressor	
Input Attenuation/Gain	-12dB to +18dB
Output Attenuation/Gain	-20dB to +20dB
Presets	16 Light to Heavy
Gain Reduction Meter	8-Segment LED
Process	In/Out (Bypass)
Expander	
Threshold Range	-70dBu to +20dBu
Ratio Range	1:1 to ∞ :1
Gain Reduction Meter	4-Segment LED
De-Esser	
Threshold Range	-40dBu to +20dBu
Frequency Range	800Hz to 8kHz
Gain Reduction Meter	4-Segment LED
4-Band Semi-Parametric Equalizer	
High Pass Filter	6dB/oct @ 80Hz
Low Shelving (± 12 dB)	100Hz
Low Mid-Range (± 12 dB)	90Hz to 700Hz
Switchable Q	0.5/2.0
High Mid-Range	450Hz to 5.8kHz
Switchable Q	0.5 /2.0
High Shelving (± 12 dB)	12kHz
Process	In/Out Switch
Master (Output) Section	
Peak-Limit Threshold Range	0dBu to +24dBu
Output Gain	-70dB to +10dB
Full Scale Output Metering	8-Segment LED (-28 to +18 dBu)

System Performance

Dynamic Range	>115dB
Noise Floor	-97.2dBu @12dB gain
THD + Noise	<0.003% (0% IDSS)
Freq. Response	10Hz to 50kHz
Input Specs	Impedance
XLR mic, 1/4" TRS line	1.3k Ω
Insert Specs	Impedance
1/4" TRS Send	1 Ω
1/4" TRS Return	10k Ω
Output Specs	Impedance
XLR	51 Ω

Stereo Microphone Preamp with Mix Bus

The MP20 is essentially a single rack space, two channel version of the M-80 with the same crystal clear microphone

/ instrument preamplification capabilities, stereo mix bus and IDSS "vintage warmth" control.



- ◆ Identical technical specifications as the M80
- ◆ 1/4" high Z instrument input on the front panel
- ◆ XLR balanced input/output connectors as well as separate send and return jacks for inserting dynamics processors
- ◆ 12 Segment level meters for each channel
- ◆ Housed in a single rack space steel chassis with a thick, high quality, blue anodized front panel

Input Specs	Impedance
XLR MIC / 1/4" TRS Line	1.3k Ω
1/4" Instrument	1Meg Ω
Insert Specs	Impedance
1/4" TRS Send	51 Ω
1/4" TRS Return	10k Ω
Output Specs	Impedance
XLR	51 Ω

BlueTube – Stereo Tube Mic/Instrument Preamp



The BlueTube is an affordable dual channel tube mic preamp that utilizes a true hybrid design that combines a 12AX7 tube stage with the same ultra low noise dual servo gain stage as it's big brothers. The Blue Tube brings world class quality to a price that fits any budget.

- ◆ Front panel mic/instrument inputs use the Neutrik Combo connector, which lets you use either 1/4" TRS or XLR connectors within the same female input
- ◆ Input gain is variable from 0 to 40dB
- ◆ A Drive potentiometer controls the amount of signal routed to the 12AX7 vacuum tube from 0 to 30dB — Higher levels of tube saturation give the signal greater warmth and a richer sound
- ◆ Switchable phase (polarity) reverse and a 20dB pad are provided for each channel
- ◆ A single +48 volt phantom power switch is used for both channels
- ◆ 8-segment Level meter for each channel
- ◆ Servo balanced XLR and unbalanced 1/4" outputs operate at +4dBu and -10dBv respectively
- ◆ Housed in a half rack space steel chassis with a high quality, anodized brushed aluminum front panel
- ◆ Fits perfectly in the PreSonus BMRA rack adapter with the PreSonus BlueMax

DigiTube – Single Channel Tube Mic/Instrument Preamp

The DigiTUBE combines a single preamp channel of the BlueTube with a three band sweepable EQ and 24bit digital output. The mic preamp features 70dB of gain with 22dB of Headroom. The three band EQ which is fully sweepable with overlapping bands for maximum tone shaping. A 24Bit Digital output via S/PDIF makes the DigiTUBE the perfect front end for soundcards and digital recorders. The DigiTUBE offers XLR analog output and TRS Insert point for patching in a compressor or other outboard effect unit.



- ◆ Tube preamp with 70dB of Gain and 22dB of Headroom
- ◆ Fully sweepable 3 Band EQ with bypass switch
- ◆ Insert point after Mic Pre for patching a comp/limiter or other outboard device
- ◆ 24Bit Digital Output via S/PDIF
- ◆ Word clock input and output via BNC Connectors
- ◆ Rackmountable via optional BMRA Rack Adaptor

PRESONUS

ACP88

Multi Channel Dynamics Processor

The ACP88 is an eight channel dynamics processor that provides crystal clear compression, brick wall limiting and noise gating for a variety of applications including multitrack recording, live sound reinforcement, broadcast and permanent sound installations. Full featured musical compression on each channel is equipped with variable threshold and ratio controls, a choice of variable or "Auto" attack and release modes, switchable soft/hard knee compression curves as well as a multi-channel link function. The noise gates' feature set includes threshold, variable attack & release times and gate range controls. Both the Compressor and Gate sections of each channel, offers it's own Sidechain inserts that allow external triggering and spectral control of each processor.

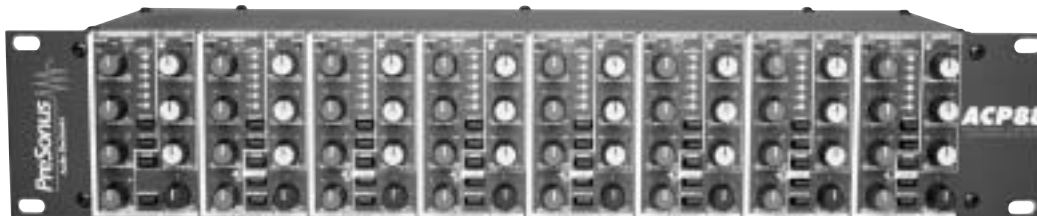

FEATURES

- ◆ At the heart of each channel is the much respected THAT 4301S VCA which offers unsurpassed dynamic range with extremely low distortion characteristics and virtually no noise

Eight Compressors/Limiters

- ◆ Each channel offers broad control over threshold, ratio, attack and release for each processor
- ◆ You can select between auto or manual attack and release curves and hard or soft knee compression types

Eight Dynamic Noise Gates

- ◆ A separate dynamic noise gate on each channel is provided with control over attack, threshold and release as well as a gate range switch
- ◆ The gate range switch allows you to select either 15dB or 60dB of level reduction. When the range switch is set at 15 dB, there will only be a slight change in the signal as it crosses the threshold which is useful in creating a more natural sounding blend or mix when gating many instruments at once

Channel Linking

- ◆ A link switch on each channel, allows you to link channels together in a subgroup to be controlled by a master processor (the channel furthest to the left in the subgroup)

Separate Bypass and Gain for Every Channel

- ◆ Each Channel has a Bypass for auditioning a signal 'before and after' processing with the compressor, limiter, or the Gate
- ◆ A Gain control is provided to make up any loss in signal level resulting from the amount of compression being applied

Compressor Sidechain

- ◆ The 1/4" TRS sidechain insert on each channel provides a send and return circuit that interrupts the signal that the compressor is using to determine the amount of gain reduction to apply
 - An EQ inserted into the sidechain using 1/4" TRS connector, accommodates frequency selective processing that allows you to, among other things, use the compressor as a de-esser or for controlling the bass frequencies while leaving the higher frequencies unprocessed.
- An audio control signal of a narrator or vocalist can be input to the sidechain. In this application, the audio that's passing through the compressor will automatically 'duck' when the narrator speaks or vocalist sings.
- ◆ When multiple channels are Linked together, the Send of the Sidechain jack of the Master channel contains a mix of all the channels in the link — this allows you to control all of the linked channels with one sidechain insert.

Gate Sidechain/Keying

- ◆ A separate 1/4" TRS Gate sidechain/Keying jack on each channel allows you to use an external sound to trigger the gate. An EQ or filter inserted at the gate key enables frequency-selective gating such as the lower frequency of a kick drum



Inputs and Outputs

- ◆ Each channel features 1/4" TRS inputs and outputs that will accept either balanced or unbalanced signals
- ◆ Each channel also features a switch on the rear panel for selecting the internal operating level between +4dBu to -10dBV

Additional Features

- ◆ Housed in a two RU, all-steel chassis
- ◆ Switchable power transformer for domestic and international use

Dual Channel Compressor, Limiter and Gate

The ACP22 is an award winning dual channel version of the esteemed ACP88 and like its big



brother is the most comprehensive stereo compressor/gate in its price range today. The ACP22 offers a full array of inputs and outputs including balanced XLR, unbalanced 1/4" as well as independent send and return Sidechains for the compressor and gate of each channel. Unique to the ACP22 over its big brother, is a switchable Lo Pass filter which blocks high frequency content such as cymbals from triggering the gate.

FEATURES

- ◆ Balanced XLR and 1/4" unbalanced inputs and outputs
- ◆ The Lo Pass Sidechain filter is designed to make the noise gate less sensitive to high frequency instruments — extremely useful for gating drums as the filter will stop cymbals from opening up the tom or bass drum gates
- ◆ The filter is set for -6dB at 2.5kHz rolling off the high frequencies at -12dB/oct
- ◆ Stereo Channel Linking allows both processors to follow the setting of channel one which becomes the master
- ◆ 8-Segment LED meters can be switched to display either input or output levels

ACP88 Input Specs Impedance
1/4" TRS 51k Ω balanced/unbalanced

ACP88 1/4" Compressor Sidechain Impedance
Send 10k Ω unbalanced
Return 51 Ω unbalanced

ACP88 1/4" Gate Sidechain Impedance
Send 10k Ω unbalanced
Return 51 Ω unbalanced

ACP88 Output Specs Impedance
1/4" TRS 51 Ω balanced/unbalanced

ACP22 Input Specs Impedance
XLR or 1/4" TS 10k Ω balanced/unbalanced

ACP22 1/4" Compressor Sidechain Impedance
Send 10k Ω unbalanced
Return 51 Ω unbalanced

ACP22 1/4" Gate Sidechain Impedance
Send 10k Ω unbalanced
Return 51 Ω unbalanced

ACP22 Output Specs Impedance
1/4" TRS 51 Ω balanced/unbalanced

System Performance

	ACP88	ACP22
Dynamic Range	>115dB	>115dB
Signal to Noise Ration	>95dB	>95dB
Noise Floor	-94dBu	—
THD + Noise (unweighted)	<0.009%	<0.02%
Headroom	—	+24dBu, unbalanced; +22dBu balanced
Frequency Response	10Hz to 50kHz	10Hz to 50kHz
Crosstalk	<82dB @10kHz	<82dB @10kHz

	ACP88	ACP22
Gate Controls		
Threshold Range	-70dBu to +20dBu	Off, -65dBu to +20dBu
Attack Time	0.01ms to 100ms	01ms to 100mS
Release Time	0.02ms to 2 sec	0.02sec to 2sec
Attenuation Range	-15dB or -60dB	0dB to -60dB
Sidechain Filter	—	Switchable Lo Pass -6dB @ 2.5kHz (12dB/oct)
Compressor/Limiter Controls		
Threshold Range	-40dBu to +20dBu	-40dBu to +20dBu
Ratio	1:1 to 20:1	1:1 to 20:1
Attack Time	0.02ms to 200 ms	0.1 ms to 200ms
Release Time	0.5ms to 500ms	0.5ms to 500ms
Auto Attack and Release	Program Dependent	Program Dependent
Curve Type	Hard and Soft Knee	Hard and Soft Knee
Output Gain	-20dB to +20dB	-20dB to +20dB
Compression Metering		
Threshold	Above/Below LEDs	Above/Below LEDs
Gain Reduction	6-Segment LED	8-Segment LED
Gate Metering	Open and Closed LED	Open and Closed LED
Power Supply	Internal, Linear Supply — Switchable for 100VAC to 120VAC or 200VAC to 240VAC	Switchable for 100VAC to 120VAC or 200VAC to 240VAC

PRESONUS

BLUEMAX

Smart Compressor / Limiter With Presets

The Blue Max is a stereo dynamics processor with 15 presets designed to offer you time-tested, compression and limiting settings used by experienced professional engineers. This dynamics processor was built with state of the art components to deliver crystal clear compression that will add punch and presence and can increase the apparent loudness of solo instruments or entire mixes. 1/4" inputs and outputs accommodate both stereo and mono operation. A high gain mono input is also provided allowing the BlueMAX to be used as a preamp for Hi-Z instruments.



FEATURES

- ◆ Designed with a single set of controls for both the left and right channels to provide true stereo compression. Can also be used as a single mono compressor and act as a preamp for high impedance instruments such as guitar and bass

15 Presets and Manual Override

- ◆ Any one of the 15 presets are accessed using a sixteen position rotary encoder which digitally switches the attack, release, ratio and threshold settings of simultaneously for each preset.
- ◆ The 15 studio proven settings include: 3 vocal presets, 8 instrument settings, 2 classic stereo settings, 2 special effects "squeeze guitar" and "pump"
- ◆ Manual mode is also provided to give you full control over compression parameters, including: Input and Output gain, Attack/release times and ratio from 1:1 to 20:1 — In manual mode the threshold is fixed at -10dB

Inputs and Outputs

- ◆ 1/4" unbalanced inputs and outputs

Sidechain

- ◆ Sidechain insert allows the unit to be used for special processing applications such as de-essing and ducking

Metering

- ◆ Full LED metering for input and output levels are available as well as separate meters for gain reduction

Additional Features

- ◆ Internal operating levels are switchable from +4dBu to -10dBV
- ◆ Internal power supply is internally switchable from 120 and 240 volt operation

Inputs and Outputs	Unbalanced 1/4" TS
Operating Level	+4/-10dB Selectable
<i>Compressor/Limiter Controls</i>	
Input Gain	-20dB to +40dB
Presets	15, Plus manual Override
Ratio	1:1 to 20:1
Attack	0.01ms to 100ms
Release	10ms to 500ms
Output Gain	-20dB to +20dB
<i>Metering</i>	
Threshold	Above/Below LEDs
<i>8-Segment LED Metering</i>	
Input/Output	-24dB to +24dB
Gain Reduction	-1dB to +28dB
Power Supply	Switchable for 100VAC to 120VAC or 200VAC to 240VAC

System Performance

Dynamic Range	>115dB
Signal to Noise Ratio	>95dB
Headroom	+24dBu
Frequency Response	10Hz to 50kHz
Crosstalk	>82db @ 10kHz
THD + Noise	<0.03%

Input Specs

1/4" TS Left/Mono
1/4" TS Right

Impedance

100k Ω unbalanced
10k Ω unbalanced

1/4" TRS Sidechain

Send
Return

Impedance

10k Ω unbalanced
51 Ω unbalanced

Analog Output Specs

1/4" TS

Impedance

51 Ω balanced / unbalanced

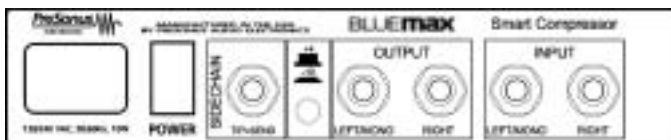

Digital Stereo Graphic Equalizer Plus Dynamics Processing

The DEQ624 is a 24-bit digital two channel/stereo 31 band graphic equalizer with a number of features that extends its capabilities way beyond those of a standard graphic EQ including variable high and low

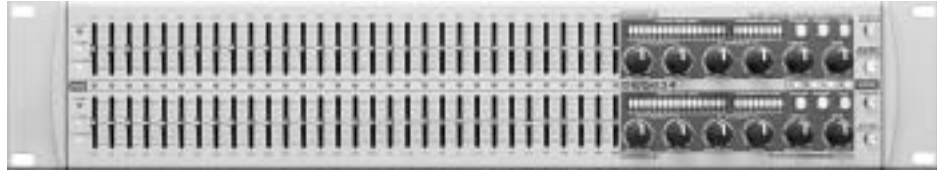

pass filters, brick wall limiting and expansion (noise reduction) for each channel. Another feature, unique to the DEQ624 is a proprietary Adaptive Hum Cancellation algorithm that allows you to virtually eliminate 60-cycle ground hum at the flick of a switch. Although the DEQ624 is a digital processing unit, under digital control it has a familiar analog feel with 20mm digital encoding faders, knobs and switches — no menus or sub-menus to scroll through that will slow you down on the gig. The rear panel of the DEQ624 provides balanced XLR and 1/4" TRS inputs and outputs as well as barrier-strip terminals for permanent installation.

Graphic EQ Plus

- ◆ 24-Bit digital signal processing provides accurate processing of analog signals
- ◆ Each channel of the graphic EQ section is comprised of 31 digital EQ encoders (faders) centered in 1/3 octave increments from 20 Hz to 20 kHz
- ◆ A range switch for each channel lets you choose one of three boost/cut ranges for the digital encoders – ±6dB, ±12dB or +12/-24dB. The selected range is easily identified by LED's located at the left side of the EQ section
- ◆ Separate high and low pass filters are provided for each channel —
 - > The low pass filter is variable from 10 kHz to 20 kHz
 - > The high pass filter is variable from 10 Hz to 410 Hz
- ◆ To help minimize overall system noise, both channels have separate expanders with variable ratio and threshold controls

- ◆ A "brick-wall" limiter with a variable threshold control provides fail-safe system protection from extreme transients
- ◆ A HI Q switch let's you narrow the bandwidth of the frequency bands from Normal Q with a 1/3 octave bandwidth to Hi Q which has a 1/8 octave bandwidth. With Hi Q engaged, adjacent frequencies will be less effected by boost/cut frequencies
- ◆ AHC-Adaptive Hum Cancellation is a proprietary feature of the DEQ 624 that allows you to greatly reduce 50 Hz /60 Hz system hum caused by grounding problems with the flick of a switch
- ◆ A hardwire bypass switch for each channel ensures that audio will still pass from input to output in the event of lost power
- ◆ To facilitate ease of set-up, a Channel A master switch, when engaged, will slave the controls of Channel B to Channel A

Preset Management

- ◆ A preset switch lets you toggle through four user-defined setups that include a "snapshot" of the settings of the front panel controls
- ◆ A security lock-out feature, allows you to defeat the front panel controls of the unit which can be restored with user-created three-switch code combination

System Performance

Dynamic Range	>105dB
Noise Floor	-95dBu
Signal to Noise	-90dB
Power Supply Rejection	-98dB
Headroom	+22dBu
Frequency Response	10Hz to 22kHz ±0.5dB
THD + Noise (Un-weighted)	0.005%

Input Specs	Impedance
XLR, 1/4" TRS & Barrier strip	12k Ω

Output Specs	Impedance
XLR, 1/4" TRS & Barrier strip	51 Ω

Inputs and Outputs

- ◆ XLR and 1/4" TRS balanced inputs and outputs are provided as well as barrier-strip terminals for permanent installations

Metering

- ◆ Each channel offers a 20-segment LED meter for output gain as well as 10-segment LED for gain reduction metering

Additional Features

- ◆ Internal power supply
- ◆ Custom molded extruded aluminum and steel chassis

Inputs and Outputs	Electronically balanced XLR, 1/4" TRS and barrier strip
Output Gain Control	-20dB to +20dB
<i>Graphic EQ</i>	
Digital EQ Controllers	20mm faders — adjustable ±5 steps
Selectable Boost/Cut Range	±6dB, ±12dB or +12/-24dB
Switchable Hi Q Control	1/3 oct (Normal Q) to 1/8 oct (Hi Q)
<i>Filters</i>	
Hi Pass Filter	12dB/oct variable from 10 Hz to 410 Hz
Low Pass Filter	12dB/oct variable from 10 kHz to 20 kHz
<i>Limiter</i>	
Threshold Control	off to 0dBu
<i>Expander</i>	
Ratio	1:1 to ∞:1
Threshold Control	off to -10dBu
<i>Metering</i>	
Output Gain	20-segment LED (-42dBu to +22dBu)
Gain Reduction	10-Segment LED (-12dBu to -0.5dBu)
Power Supply	Factory configured for 115V

PRESONUS

CL44 and GTX44

Quad Series Dynamics Processors

Presonus' Quad Series dynamics processors consist of the CL44 Four Channel Professional Compressor/Limiter and the GTX44 Four Channel Frequency Dependent Gate/Expander. Both



units combine a digitally controlled, high quality analog signal path with the added flexibility of digital sidechain processing which provides vintage compressor emulations, ducking and spectral processing. The GTX44 features high and low pass filters, variable attack, release and hold parameters and key listen control. The CL44 has a variable Hi Pass Filter with an independent limiter and full featured compressor. Both units also feature stereo linking of adjacent channels as well as sidechain inserts, balanced XLR inputs and outputs and a single unbalanced 1/4" TRS I/O connector for each channel.

FEATURES

- ◆ Hybrid VCA, analog dynamics processor under digital control with DSP flexibility
- ◆ Digital sidechain processing allows multiple functions such as filtering, vintage compressor emulation and other special functions, to be applied simultaneously

Inputs and Outputs

- ◆ Balanced XLR inputs and outputs
- ◆ Unbalanced inputs and outputs are also available via a single 1/4" TRS jack – A 'flip' button reverses the 'tip' and the 'ring' on the 1/4" jack to match the wiring of your mixer
- ◆ 1/4" TRS compressor sidechain insert with +4/-10dBv selector

Additional Features

- ◆ Adjacent channels are stereo linkable
- ◆ Internal Power Supply
- ◆ Backlit function buttons
- ◆ All steel chassis, one rack space



Partial rear view of GTX44

CL44 Features

- ◆ Fully adjustable attack, release, ratio, threshold control
- ◆ Variable High Pass Filter Allows you to pinpoint the frequency range in which the compressor operates
- ◆ Independent peak stop limiter
- ◆ Program dependent attack and release is also available using the Auto function that monitors audio over three separate time constants
- ◆ Compander (upward expander) circuit raises an audio signal when it falls below a desired threshold – when used in conjunction with the compressor provides Automatic Gain Control
- ◆ Special 'optical' mode emulates the optical transfer curve found in vintage compressors
- ◆ 10 segment LED gain reduction meter

CL44 Panel Controls:

Low Cut Filter	20Hz-8kHz
Threshold	+15dBu to -40dBu
Ratio	1:1 to 20:1
Gain	-20dB to +20dB
Compad	0% to 100%
Attack	01mS to 500mS
Release	01S to 3S
Limit	-10dBu to 24dBu (Off)
Optical Mode Switch	
Link 1-2 and 3-4 Switch	
Auto Switch	
Bypass Switch	
Gain Reduction Meters	LED -0.5dB to -24dB

GTX44 Features

- ◆ Variable threshold, ratio, attack, release hold and range controls can be applied to achieve noise-gating or downward expansion
- ◆ Adjustable High- and Low- Pass filters allow you to control the specific frequency range over which the gate will open – a sidechain monitor listen button lets you hear what frequency range the gate is operating within
- ◆ Duck mode allows for external input of microphone signal via Gate Key Input

Zero-Crossing Circuit

- ◆ Zero-Crossing function provides truly 'clickless' operation and chattering on gate settings that use quick attack-times

GTX44 Panel Controls

Low Cut Filter	20Hz-8kHz
Hi Cut Filter	250Hz-20kHz
Threshold	+15dBu to -40dBu
Ratio	1:1 to Gate
Range	0dB to -80dB
Attack	01mS to 500mS
Hold	001S to 1S
Release	01S to 2S
Sidechain Monitor Switch	
Link 1-2 and 3-4 Switch	
Duck Switch	
Bypass Switch	
Performance	
Gain Reduction Meters	LED -3dB to -30dB

PRESONUS

ACOUSTI-Q

Tube Blender/Preamp

The ACOUSTI-Q is an affordable tube-based preamp/blender for acoustic instruments featuring Presonus' award winning dual servo gain stage design. The ACOUSTI-Q is the perfect solution for acoustic



musicians helping to bring their personal style and sound to new heights! The ACOUSTI-Q gives you the choice to use a single (piezo pick-up) or dual (piezo pick-up and mini- internal microphones) source. With two sources, you can blend the signals to achieve the perfect mix. Guitars, woodwinds, basses, brass instruments virtually any acoustic instrument can benefit from the warm tube sound of the ACOUSTI-Q. The ACOUSTI-Q employs two dual-servo microphone preamplifiers with separate gain controls for input, a phase switch, a 12-volt phantom power supply to accommodate miniature, internal condenser microphones, a variable notch filter and sweepable mid- band EQ, as well as low and high shelving EQ controls. The master output section gives you the ability to set two separate volumes, one for normal volume, and the other, a boost, for solo playing.

Two Preamps

- ◆ The front panel instrument input is designed to handle 1/4" TRS inputs from instruments equipped with both mini-condenser microphones and piezo pick-ups or 1/4" TS from instruments equipped with pick-ups only
- ◆ A dual concentric volume control allows you to blend the incoming signals of two inputs
- ◆ A 12AX7 vacuum tube, after the master output, harmonically enhances the final signal
- ◆ +12VDC Phantom power is available to the Ring of the 1/4" TRS input for use by mini-condenser microphones installed in some acoustic instruments
- ◆ A phase (polarity) reverse switch compensates for different connector hook-ups and can also be used to achieve an intentional 'out-of-phase' sound
- ◆ A tunable Notch Filter variable from 92 - 494 Hz ± 12 dB is available via a dual concentric knob for isolating and controlling lower frequencies that may be prone to feedback
- ◆ A 3-band EQ is provided via a pair of dual concentric potentiometers
 - > The dual mid-range control features a sweepable frequency range from 250Hz to 5kHz and a boost and cut of ± 12 dB
 - > A brilliance control is provided with a fixed shelving frequency of 8kHz and a boost and cut of ± 12 dB
 - > A bass control is also provided with a fixed shelving frequency of 100Hz and a boost and cut range of ± 12 dB
- ◆ The Master section also uses a dual concentric knob to control
 - > The inner knob controls the Main output level from -80dB to +20dB
 - > The outer knob, labeled Cut/Boost Footswitch, sets the amount, ± 12 db, that the output signal will be raised or lowered when used with an optional footswitch
- ◆ A Mute switch defeats the Main output while allowing the signal to remain present at the -20dB AMP/TUNER output
- ◆ A 16 segment LED meter, with a range of 42dBu to +24dBu (clip), is provided for monitoring the unit's Main output level

Rear Panel Connections

- ◆ Balanced XLR main output
- ◆ A 1/4" TRS Effects Loop jack allows you to insert outboard effects (compressors, delay units, or reverbs). The Effects Loop can also be used as an additional output when used with a 1/4" TS cable
- ◆ An unbalanced 1/4" jack, operating at -20dB is provided as a signal source for Tuners and guitar amplifier inputs.
- ◆ A 1/4" footswitch input is also provided for muting the main output as well as facilitating the previously mentioned instantaneous boost or cut capabilities

1/4" TRS Inputs	
Tip	For standard pickups
Ring	For mini condenser mics
Input Controls	
Tip Volume	0dB to 40dB
Ring Volume	0dB to 40dB
Phase Invert	Switchable Polarity
Phantom Power (Ring)	Switchable +12VDC
3-Band Equalizer	
Mid Range	Sweepable 250Hz - 5kHz
Bass	Fixed Shelving 400Hz
Brilliance	Fixed Shelving 8kHz
Boost/Cut	± 12 dB for all bands
Notch Filter	92 - 494 Hz (± 12 dB)
Master Section	
Mute	Main Output Only
Master Level	-80dB - +20dB
Cut/Boost	± 12 dB (Footswitch Only)
Metering	
Threshold	Above/Below LEDs
8-Segment LED Metering	
Input/Output	-24dB to +24dB
Gain Reduction	-1dB to +28dB

System Performance

THD + Noise (Unweighted)	0.005% (0dBu) 0.05% (+10dBu output); 0.3% (+20dBu output)
Signal to Noise	>90dB

1/4" TRS Input Specs	Impedance
Tip	10M Ω unbalanced
Ring	10M Ω unbalanced
Ring w/ Phantom Power	3.2k Ω unbalanced

1/4" TRS Effects Loop	Impedance
Send (Tip)	51 Ω unbalanced
Return (Rings)	50k Ω unbalanced

Output Specs	Impedance
Main Out (XLR)	51 Ω balanced
1/4" TS Tuner/Amp -20dB	51 Ω unbalanced

PREAMPLIFIERS

AP 13 Acoustic Instrument Processor

The AP13 is a dedicated preamp/processor specifically designed to blend the signals from



acoustic instruments with two pickups. A single 1/4" TRS jack on the front panel, will accept both a very high input impedance piezo pickup and a microphone pickup simultaneously. Each of the two pickup signal paths feature powerful mixing and processing capabilities optimized for preserving the timbre of acoustic instruments while minimizing feedback, including individual Pan and Level controls, a variable Low Cut Filter and 7-band Graphic Equalizer. The AP13's wide ranging I/O capabilities include a stereo effects loop and Insert for each channel, balanced 1/4" line-level and stereo XLR mic-level outputs, a stereo headphone output with level control as well as dedicated 1/4" piezo pickup and tuner output connectors.

FEATURES

- ◆ A stereo 1/4" TRS input jack combines the individual signals from any acoustic instrument with two pickups but will also accept instruments with only one pickup
- ◆ A front panel switch lets you choose which pickup is wired to the tip or the sleeve of the Input jack
- ◆ Two signal processing paths one optimized for piezo pickups and one for mic pickups
 - ✦ The piezo path features very high input impedance for extended low bass response
 - ✦ The mic channel offers a choice of two phantom power voltages, +6Vdc and +15Vdc, satisfying the requirements of most electret condenser mic pickups
 - ✦ Either channel accepts dynamic pickups or line-level outputs

Flexible Outboard Processing

- ◆ Separate stereo send/return and insert loops for each channel allow seamless integration of effects and/or outboard dynamics processors into the signal chain
 - ✦ Individual send A/B controls adjust the amount of signal sent to 1/4" TS send jacks while a single stereo return control adjusts the signal entering the 1/4" TS return jacks
 - ✦ The insert loops for channels A and B are accessed via 1/4" TRS jacks

Each Channel Features

- ◆ Bump-proof input trim controls feature slotted openings to allow quick adjustment using picks, fingernails or coins
- ◆ Red overload indicators for each type of pickup make gain set-up easy
- ◆ An invert switch solves the annoying problem of out-of-phase pickups
- ◆ 12dB/oct Low Cut Filters, variable from 15 to 250 Hz help eliminate unwanted bass frequencies
- ◆ The 7-band graphic EQs give you separate timbre control over each pickup with ± 12 dB boost/cut and a 2 octave bandwidth per band
- ◆ Pan and level controls allow you to mix both pickups into one perfectly blended stereo signal
- ◆ The Low Cut filter, 7-band graphic EQ, pan, level, send and return Level controls are all logically arranged along the front panel using smooth-acting oil-damped sliders to provide ease-of-use and graphical feedback

Outputs

- ◆ Two pair of simultaneous, high-current cross-coupled balanced (mono switchable) stereo line drivers are provided
 - ✦ The stereo 1/4" TRS line-level outputs are provided for driving amplifiers
 - ✦ XLR mic-level outputs accommodate direct console patching
- ◆ A powerful stereo headphone amp with level control and Master Mute switch allow private auditioning and practice
- ◆ A 1/4" piezo output with a dedicated level control is available as an auxiliary output
- ◆ Separate 1/4" tuner output

Additional Features

- ◆ 1/4" TS expander inputs accommodate an external audio source such as a CD or tape for practicing
- ◆ UL/CSA/CE and 100/120/230 VAC remote power supplies

System Performance

Frequency Response	15-40 kHz, +0/-3 dB
Signal-to-Noise Ratio re +4 dBu, 20 kHz BW	81dB
THD+Noise (+4 dBu, 20-20 kHz)	0.03
Equivalent Input Noise (EIN) 60dB gain	
	120dB Inst Mic In to Send
	115dB Inst PZO In to Send



PREAMPLIFIERS

DMS 22 2-Channel Microphone Preamplifier



The DMS 22 is a dual channel studio-grade mic preamp with 3-bands of equalization and a stereo mixer. Perfect for studio recording in direct-to-tape or hard disk applications with audio quality surpasses that found in most professional mixing consoles. The two balanced XLR microphone inputs features switchable 48V phantom power, polarity invert switch, and variable input gain. Balanced 1/4" TRS line outputs with level control is provided for each channel. Each channel also features a defeatable pan control sent to a separate stereo pair of XLR mix outputs, allowing a stereo mix of the two microphones when hard left/right is not appropriate. The 3-band EQ (High and Low shelving plus a fully parametric Mid-band) on each Channel offers a broad palette of tonal control. A selectable Low Frequency Filter is available on each output channel to remove mic bumps and rumble that might interfere with a recording. The DMS 22 goes beyond the concept of a dual mic preamp in two ways—the built-in Mixer section, and the comprehensive Equalizer circuitry. This built-in mixer for the two Channels eliminates the need for an external console when a portable setup is desired.

FEATURES

- ◆ Each XLR microphone input features switchable 48v phantom power, polarity invert switch, and input gain control

3-Band Equalizer

- ◆ Each channel features low and high shelving bands and a parametric mid band, each with a boost/cut range of +12/-15 dB
- ◆ Patented Accelerated-Slope tone controls with steep phase-corrected slopes eliminate most of the traditional interaction between shelving and midband controls
- ◆ The low and high bands provide switch selectable shelving frequencies
 - > Low – 50 Hz and 100 Hz
 - > High – 7 kHz and 12 kHz
- ◆ Parametric bandpass Mid band
 - > Sweepable frequency, variable from 95 to 4k Hz
 - > 3-position Q control switchable to 0.33 / 1.0 / 2.0 oct bandwidths
- ◆ An EQ engage switch serves as a bypass control of the EQ section
- ◆ A selectable 15/50/100 Hz low frequency filter is provided on each channel



Stereo Mixer and Outputs

- ◆ Independent (defeatable) pan controls for each channel allow you send a stereo mix of the two mic channels into a pair of XLR mix outputs, adjustable by a stereo output level control — this can be useful when recording direct-to-tape or disk
- ◆ Balanced, line-level 1/4" TRS outputs with Level controls are provided for each channel
- ◆ The direct outputs and stereo mixer outputs are available simultaneously

System Performance

Equivalent Input Noise	-130 dBu (full bandwidth, 60 dB gain, 150 Ω)
Frequency Response	20-20 kHz +0/-0.5 dB
Signal to Noise Ratio	97dB (re +4 dBu, +15 dB gain, full bandwidth)
THD+Noise	0.02% (+4 dBu, full bandwidth, max gain)
IM Distortion	0.03% (+4 dBu)
Mic Input	Impedance 1k Ω
Output Impedance	100 Ω

Input Gain Range	+15 to +60 dB
Phantom Power	+48 Vdc
3-Band Accelerated Slop EQ Section	
Boost/Cut Range	+12/-15 dB
Low Frequencies	Switchable 50 or 100 Hz
Hi Frequencies	Switchable 7k or 12k Hz
Mid Frequency Sweep	Variable from 95 to 4k Hz
Mid Bandwidth Range	3-position switch 0.33 / 1.0 / 2.0 oct
Low Frequency Filters	Switchable 15/50/100 Hz 15 dB/octave, Butterworth
Metering	
Overload LED	Threshold 16 dB
Inputs and Outputs	
Mic Inputs	RF Filtered, XLR Balanced, Max Input Level 6 dBu Min gain
Outputs	Active balanced XLR and 1/4" TRS



RANE

PREAMPLIFIERS

PROCESSORS

302

VP 12 Voice Processor

The VP 12 is a mic or line level voice processor incorporating a studio-grade microphone stage, low and hi cut filters, de-esser, gate/compressor, and two channels of parametric equalization.

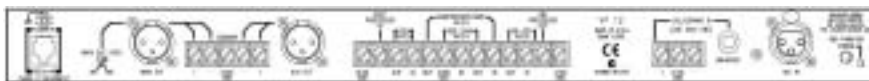

- ◆ XLR Input with switchable 48V phantom power and input gain control
- ◆ Balanced screw terminal and 1/4" TRS line level inputs
- ◆ The line level input is designed to easily accept the output of wireless mic systems
- ◆ A front panel switch selects whether the mic, line, or the sum of both inputs will be processed
- ◆ The sum feature allows the line input to function as an aux input for additional outboard mic preamps
- ◆ Variable Low and Hi-Cut Filters tailor the overall frequency range to the specific application.
- ◆ A de-esser features variable frequency and threshold controls to help remove sibilance

Gate and Compressor Controls

- ◆ The gate features a variable threshold control and a 3-position ratio control that insures a smooth transition from active output to off without pumping artifacts
- ◆ The compressor features variable threshold and ratio controls
- ◆ Seven-segment gain reduction meter lets you know just how much the compressor is compressing

Two band Parametric EQ

- ◆ Each band has a multiplier switch that covers a frequency range of 10 to 20k Hz with +12 dB of Boost and -15 dB of Cut as well as a variable wide to narrow bandwidth control
- ◆ Because the filters are in series, setting the filters to the same frequency can double the amount of available boost or cut

Outputs

- ◆ Dual concentric front panel level controls for both the main and aux outputs
- ◆ Fully balanced XLR and screw terminal main outputs switchable to either line or mic level as well as fully balanced XLR and screw terminal aux outputs – main and aux outputs can both be used at the same time
- ◆ Independent six-segment LED meters for the main and aux outputs are accurately calibrated in peak dBu

Additional Features

- ◆ Independent bypass switches are provided for each processing section
- ◆ Each section of processing can be re-patched in any order via screw terminal jumpers on the rear of the unit

System Performance

Frequency Response	20 - 20k Hz +0/-3 dB EQ out, no cut filtering
Signal to Noise Ratio	97 (re +4 dBu) dB +15 dB gain, 20 kHz BW
THD+Noise	0.2 % +4 dBu, 20-20 kHz BW max gain
IM Distortion	0.03% (+4 dBu, 60 Hz/7 kHz, 4:1)
Equivalent Input Noise	-130 dBu 20 kHz BW, 60 dB gain, 150 ohms

Input Specs	Impedance	Maximum Input Level
XLR Mic	1k Ω Balanced	+3.5 dBu
1/4" TRS and screw terminal line	20k Ω	+20 dBu
Output Specs	Impedance	Maximum Output Level
	100 Ω	

RF Filtered Inputs	
Mic	XLR Balanced
Line	Active Balanced/Unbalanced 1/4" TRS and Screw Terminal
Preamp Controls	
Gain Range	+15 to +60 dB
Phantom Power	+48 VDC
12dB/Octave Low & Hi Cut Filters	
Low Cut Filter	Variable from 10 Hz to 250 Hz
Hi Cut Filter	Variable from 3 kHz to 40 kHz
De-esser	
Frequency Range	700 Hz - 9 kHz
Threshold	-50 to +20 dB
Ratio Settings	Switchable Mild, Norm, Max %
Gate Controls	
Threshold Range	-50 to +10 dB
Ratio Settings	1.5:1, 2:1, 3:1 (Switchable)
Compressor Controls	
Threshold Range	-50 to +20 dB
Ratio Range	1:1 to 10:1
Two-Band Fully Parametric EQ Section	
Frequency Range	10-20 kHz
3-position range switch	
x0.1	10 Hz to 200 Hz
x1.0	100 Hz to 2 kHz
x10	1 kHz to 20 kHz
Boost/Cut Range	+12/-15 dB
Bandwidth	.03 to 2 Octaves
Outputs	Active balanced 1/4" TRS and screw terminal
Metering	
Gain Reduction	7-Segment LED
Main	6-Segment LED
Aux	6-Segment LED

All Rane products are certified to meet all local and federal agency regulations. Specific agency listings are available on applicable data sheets.



EQUIPMENT LEASING AVAILABLE

PREAMPLIFIERS

MS 1b Microphone Preamplifier

The Rane MS 1b is a compact mic preamplifier designed for direct recording or for adding a microphone channel to line-level mixers. Go from either a dynamic, condenser or electret microphone to a line-level input with a minimum of noise, distortion, cost and hassle. The MS 1b utilizes one of the finest ultra low noise amplifier designs available.



Featuring a true differential input with high common-mode rejection, use of the MS 1b guarantees performance usually found only in mixing consoles costing thousands of times as much.

- ◆ Ultra low-noise, low distortion design utilizing the Burr-Brown mic preamp chip improves the dynamic range and boosts performance over the original MS1
- ◆ RF filtered XLR balanced input
- ◆ Continuously variable rotary gain trim between 18 dB and 66 dB
- ◆ Switchable 48 volt phantom power with indicator LED
- ◆ Polarity switch
- ◆ Signal/overload LED
- ◆ Can mount close to the mic to provide a local volume control, with a stronger signal that minimizes RFI and hum
- ◆ True high current cross-coupled XLR balanced output line driver designed to emulate a transformer output
- ◆ U.L. listed, C.S.A. certified, and CE certified

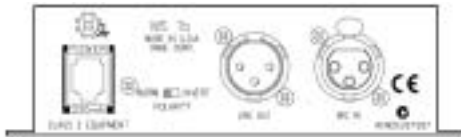

System Performance

Signal to Noise Ratio (18 dB Gain)	96 dB 20Hz -20kHz, 150Ω (+4 dBu)
Equivalent Input Noise (60 dB Gain)	-128dBu (typical) 20Hz -20kHz, 150Ω
Dynamic Range (18 dB Gain)	120 dB typical
CMRR (60 dB Gain)	80 dB (typical) 150Ω, 120 Hz
Frequency Response (18 dB Gain)	30 to 200k Hz (+0, -3dB)
THD+Noise (18 dB Gain)	.001% (Output=+20 dBu) 50 to 20k Hz, 20 kHz BW, 10k Ω

Input Specs	Impedance	Max. Input Level
XLR	10k Ω Balanced	+10 dBu (Gain 18dB)
Output Specs	Impedance	Max. Output Level
XLR	50 Ω	+22 dBu (unbal)/+27 dBu (bal) 2k Ω load

PS 1 High Fidelity Phono Preamplifier

The PS 1 Phono Stage is a complete professional RIAA phonograph stereo preamplifier designed for studio and remote turntable applications as well as permanent archival installations such as libraries, schools and museums. The PS 1's features include balanced screw terminal outputs capable of driving extremely long lines, the correct loading capacitors for all popular phono cartridges, and properly designed rumble filters that remove infrasonic signals without interfering with the audio signals. Ideal for expanding existing systems or for mixers which have no available phono inputs.



- ◆ Converts RIAA (phono) to line level with 0.1 dB RIAA accuracy
- ◆ Selectable cartridge loading capacitors
- ◆ 18 dB/oct rumble filter @ 15 Hz
- ◆ Cross-coupled high-current line drivers with balanced screw terminal & unbalanced RCA outputs
- ◆ Pristine audio path using audio grade components
- ◆ Linear tech and analog devices IC'S
- ◆ UL/CSA/CE remote power supply

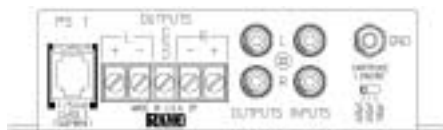

System Performance

Max Output Level	+22 dBu Cross-coupled balanced into 600 Ω
Output Impedance	50 / 100 Ω Balanced / unbalanced
Channel Separation	80 dB 1 kHz (50 dB @ 20 kHz)
THD+Noise	0.02% (+4 dBu, 20-20 kHz)
Signal-To-Noise Ratio	84 dB (re +4 dBu, 20 kHz Noise BW)
Gain	+42 / +36 dB Balanced / unbalanced out
RIAA Equalization Accuracy	0.1 dB NAB (RIAA) standard curve
Infrasonic (Rumble) Filter	15 Hz, 18 dB per Octave Butterworth high-pass
Input Capacitance	Selectable 100 / 250 / 425 pF

COMPRESSOR/LIMITERS

DC 22 2-Channel Dynamic Controller

The DC 22 is an easy to use, dual channel, dynamic controller that combines high quality VCA compression

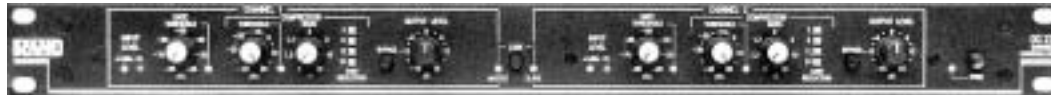

and gating with downward expansion. The Compressor section features a variable threshold ratio control capable of subtle dynamics control to peak limiting. The Expander/Gate musically attenuates signals below the set threshold level. This in contrast to a Gate only which shuts off any signals below the threshold. The link switch allows the DC22 to be used for true stereo or independent dual channel processing. Compatible with balanced and unbalanced equipment. Designed for the working musician or DJ, The DC 22 provides reduced complexity without compromise in audio quality or dependability.

FEATURES

- ◆ Dual channel compressor/gate using high quality log RMS (averaging) detectors and VCAs
- ◆ A link switch allows the DC22 to be used as a true stereo processor with channel 1 controlling both channels

Inputs & Outputs

- ◆ Both XLR balanced and 1/4" TRS balanced/unbalanced inputs are provided
- ◆ An input gain switch, on the rear panel, allows you to connect professional (+4dBu) and consumer (-10dBv) equipment to the 1/4" TRS inputs
- ◆ XLR balanced and unbalanced 1/4" TS outputs connectors are also provided

Expander/Gate

- ◆ The adjustable gate is a downward expander (a compressor working in reverse) with a variable threshold control and fixed ratio of 2:1. When the signal drops below the set threshold, the gate threshold indicator lights and the output level is reduced by 2 dB for every 1 dB the input signal level drop

Compressor

- ◆ The compressor features variable threshold and a ratio controls
- ◆ The ratio control is variable from 1:1 up to ∞:1 to allow the compressor to be used for limiting applications including system protection and digital recording
- ◆ The ±15dB output level controls provide make-up gain lost due to compression

	DC22	DC24
Expander / Gate		
Threshold Range	-20 to +80 dB	-50 to +10 dB
Ratio Range	2:1 (fixed)	1:1 to 20:1
Threshold Activity Meter		LED
Compressor		
Threshold Range	-40 to +10 dB	-50 to +20 dB
Ratio Range	1:1 to ∞:1	1:1 to 10:1
Threshold Activity	LED	LED
Gain Reduction	4-Segment LED (-3 to -24dBu)	-
Limiters		
Threshold Range	-	-20 to +20 dB
Gain Reduction	-	5-Segment LED (0 to -24dBu)
Crossover		
Linkwitz-Riley	-	4th-Order 24 dB per octave slopes
Frequency Range	-	70 Hz to 7 kHz (41-detent pot)
Output Section		
Gain Range	±15dB	±12 dB, center detent @ unity gain
Bypass Switch	✓	Hardwire
Signal Present LED	+4 dBu	-40 dBu
Overload LED	✓	+22 dBu
Inputs	20k Ω / Max Input +20dBu	20k Ω / Max level +20dBu
XLR Inputs	Balanced	Balanced
1/4" TRS Inputs	Bal/Unbal (switchable +4dBu/-10dBv)	
Outputs	Max Output Level +20dBu (2kΩ)	Max Input level +20dBu (600Ω)
XLR Outputs	100 Ω Balanced	100 Ω Balanced
1/4" Outputs	300 Ω TS Unbalanced	100 Ω TRS Balanced
1/4" TRS SideChain	-	Tip = Send, Ring = Return

System Performance

	DC22	DC24
Frequency Response	20 Hz - 40 kHz +0/-0.5 dB R load > 2 kHz	20 Hz-20 kHz (+0/-0.5 dB)
THD+Noise	0.02% type. (+4 dBu, 1 kHz)	0.05% type. (+4 dBu, 1 kHz)
IM Distortion (SMPTE)	-	0.1% (60 Hz / 7 kHz, 4:1, +4 dBu)
Signal-to-Noise Ratio	100dB (Unity gain, +4 dBu, 20kHz BW)	92dB (Unity gain +4 dBu, 20kHz BW)
Common Mode Rejection	40dB min.	

COMPRESSOR/LIMITERS

DC 24 2-Channel Dynamic Controller with Built-in Crossover

The DC 24 is a two channel dynamics processor with independent expander/gate and



compressor functions as well as dedicated limiter circuits that provide overall system protection on top of the other dynamics controls. Unique to the DC 24 is its built-in 24 dB/octave Linkwitz-Riley crossover which allows the unit to operate as a two-way speaker dividing network or for multiband dynamics control of a single audio source. Both balanced XLR and balanced/unbalanced 1/4" TRS inputs and outputs are provided as well as a 1/4" TRS side-chain insert on each channel.

SAME FEATURES AS THE DC22 PLUS—

- ◆ The expander/gate section features variable threshold as well as ratio controls allowing you to select the amount of downward expansion — higher ratios will provide greater attenuation to signals below the set threshold.
- ◆ The attack and release times of the compressor and expander/gate circuits use dedicated RMS-sensing ICs that automatically adjust to the program material –
 - > If the input is predominantly low frequency, the times are made more gradual and slowed
 - > For more transient signals, the times are tightened

Limiter

- ◆ Limiter circuits, located after the compressors, feature their own threshold control, providing dedicated peak-stop limiting before the units output

Crossover

- ◆ 24 dB/octave Linkwitz-Riley crossover with two operating modes —
 - > Low-High crossover mode (1 In/2 Out) allows the DC24 to be used as a two-way speaker dividing network along with a fully featured expander/gate, compressor and limiter on each output
 - > Bandsplit Combine mode (1 In/1 Out) Provides multi-band dynamics processing by dividing a single channel of audio in two separate frequency ranges that can independently processed and then recombined into one channel

Inputs and Outputs

- ◆ RF filtered, active balanced XLR and bal/unbal 1/4" TRS inputs and outputs
- ◆ -10 dBV / +4 dBu gain switch
- ◆ 1/4" TRS side-chain inserts, on each channel, allow spectral dynamics and ducking control from external sources

Additional Features

- ◆ Passive hard-wire bypass switches ensure total bypass of the unit's active circuitry in the event of power failure
- ◆ All steel construction
- ◆ UL/CSA remote power supply (120 VAC)



The following is taken from "Squeeze Me, Stretch Me: The DC 24 Users Guide" to expound the virtues of the DC-24's split-band dynamics processing capabilities.

The DC 24 has two great advantages over other compressors – the crossover and the dual channels. It gives you complete control of the signal and processing of it. This is something that wasn't available before in a single unit. One stereo or two mono comp/limiters and one crossover would be required to do what the DC 24 does in a single rack space.

Use it on bass guitar, piano, drums, vocals — anywhere you've used a compressor/limiter before. The DC 24 gives you more control and a less tortured sound. In fact, split-band processing works so well that a DC 24 sounds good compressing an entire mix (two required for stereo in split-band mode).

Of special interest are instruments which have large level differences in their different tonal ranges. String pops on a bass are one, but flute is another. The higher tones require more breath and are much louder than the lower. Another good application would be a drum mix or submix. A split-band compressor does a better job of smoothing the performance out.

PARAMETRIC EQUALIZERS

PE 15 5-Band Parametric Equalizer

The PE 15 is a single channel parametric equalizer with five filter sections. Each of the five bands features independent control over the center frequency, bandwidth, as well as boost and cut. In addition, bands one and five can be switched to allow peaking or shelving characteristics. Special attention to the design of the state-variable filters allows any control to be operated in any order without affecting the others. Ideal for any sound shaping application from razor sharp notch filtering to broad-band program contouring.



FEATURES

5-Band EQ Section

- ◆ Five overlapping filters cover a center frequency range of four octaves
- ◆ Bandwidth for each band is variable from .03 to 1.5 octaves
- ◆ The boost/cut range of each band is variable from +15 dB to -20 dB
- ◆ Bands 1 and 5 are switchable to allow peak or shelving characteristics
- ◆ Individual bypass switches and LED indicators allow separate auditioning of each band

Flexibility

- ◆ The extra-deep 20 dB cut range and narrow (1/30th octave) bandwidth capabilities available on all 5-bands, are effective against troublesome feedback or removing any undesired slice of audio resonance without audibly affecting sonic quality
- ◆ The four octave range allows multiple band correction to the same frequencies when required — at least two bands will always overlap; most frequencies can be reached by three bands; and 1 kHz is covered by four bands.

Low & High Cut Filters

- ◆ A steep 18 dB/octave Low Cut Filter at 15 Hz, and a 12 dB/octave High Cut Filter at 33 kHz allow bandlimiting without using any of the five parametric bands

Output Section

- ◆ An overall Master Control Level covers a range of completely off to +20 dB
- ◆ A “hard-wire” bypass switch defeats all effects in the unit, ensuring that, in the event of a power failure, audio will continue to pass through the unit
- ◆ A system overload LED indicates a level of 18dBu or higher

Inputs and Outputs

- ◆ RF filtered, active balanced/unbalanced XLR and 1/4" TRS inputs
- ◆ Active balanced XLR and 1/4" TRS outputs

Additional Features

- ◆ UL/CSA/CE and 100/120/230 VAC remote power supplies
- ◆ All steel construction

Five Band Equalizer	
Type	Fully Parametric Bands 1 and 5 switchable to shelving
Boost/Cut Range	+15 to -20 dB Minimum phase design
Bandwidth Range	.03 to 1.5 Octaves Continuous sweep
Frequency Range Per Band	4 Octaves
Band 1	20 Hz to 300 Hz
Band 2	60 Hz to 1 kHz
Band 3	150 Hz to 2.5 kHz
Band 4	450 Hz to 8 kHz
Band 5	1 kHz to 20 kHz
Bypass Switches w/ LED	One per band
Filters	
Infrasonic Filter	15 Hz, 18 dB/Oct., Butterworth
Ultrasonic Filter	33 kHz, 12 dB/Octave
Output Section	
Output Gain Range	Off to +20 dB
Bypass Switch	Passive “hardwire”
Metering	
Overload LED	+18 dBu
Inputs	
XLR & 1/4" TRS	RF Filtered, Active Balanced/Unbalanced
Outputs	
XLR & 1/4" TRS	Active Balanced

System Performance

Frequency Response	15-33 kHz +0/-3dB
THD+Noise	0.02 % +4 dBu, 20-20 kHz
IM Distortion (SMPTE)	0.009 % 60 Hz/7 kHz, 4:1, +4 dBu
Signal-to-Noise Ratio	73 dB Boost/Cuts maximum, max gain 92 dB Boost/Cuts centered, unity gain (re +4 dBu, 20 - 20k Hz)

Input Specs	Impedance	Max Input Level
XLR & 1/4" TRS	20k Ω	+20 dBu
Output Specs	Impedance	Max Input Level
XLR & 1/4" TRS	200 Ω	+24 dBu (> 600 ohms)

PARAMETRIC EQUALIZERS

PE 17 5-Band Parametric Equalizer

The PE 17 is a 5-band parametric equalizer/notch filter with advanced features and performance capabilities over the PE 15's already well thought out design. Some of these enhancements include separate in and out gain controls, 100% overlapping bands for all 5

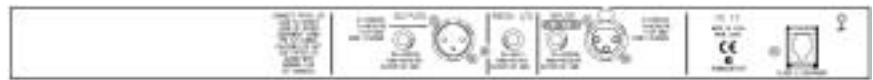

EQ sections as well as improved dynamic range and noise performance. Special design techniques and components used in the design of the PE 17 guarantee residual noise levels below digital recording equipment. This makes the PE 17 ideally suited for any critical digital audio studio, sound reinforcement and broadcast applications.

FEATURES

5-Band EQ Section

- ◆ All five parametric bands are identical and offer 100% overlap with a frequency sweep range of 10 Hz to 20 kHz. This provides the unit with the flexibility to allow:
 - > All bands to work together within a specific frequency range with summing of boost and cut
 - > For each band to cover five separate parts of the audio spectrum *or*
 - > Anywhere in between
- ◆ Each filter has a boost/cut range of +12 dB to -15 dB as well as continuously variable bandwidth control from as narrow as 1/30 of an octave to as wide as two octaves

Low and High Cut Filters

- ◆ Variable 12 dB/octave Low and High Cut band limiting Filters offer great flexibility for tailoring a sound systems overall frequency response to its exact application
 - > The Low Cut Filter has a range of 10 Hz to 250 Hz
 - > The High Cut Filter has a range of 3 kHz to 40 kHz

Inputs and Outputs

- ◆ Balanced XLR and 1/4" TRS ins and outs
 - > The input stage uses 0.1% matched resistors, to provide superior common-mode rejection of unwanted signals
 - > The output stage uses "cross-coupled" high current line drivers which accommodate extremely long cable runs
- ◆ A 1/4" TRS patch I/O jack allows you to patch the unit into a console's insert points using a single 1/4" TRS cable

Additional Features

- ◆ Separate ±12 dB input and output gain slide controls —
 - > The In control is calibrated top-to-bottom ±12 dB, while the Out is calibrated just opposite. This allows you to move both sliders together, ensuring that you always maintain unity gain through the EQ section, while varying the gain/attenuation occurring at the unit's input or output
- ◆ A system overload LED illuminates when signals come within 3-4dB of clipping

Five Band Equalizer	
Type	Fully Parametric
Boost/Cut Range	+12 to -15 dB Minimum phase design
Bandwidth Range	.03 to 2 Octaves Continuous sweep
Frequency Range Per Band	100% Overlap via three frequency range switches
Freq Sw: x.1	10 Hz to 200 Hz
Freq Sw: x1	100 Hz to 2 kHz
Freq Sw: x10	1 kHz to 20 kHz
Bypass Switches w/ LED	One per band
Variable 12 dB/Oct Butterworth Filters	
Low Cut Filter	10 Hz-250 Hz
High Cut Filter	3 kHz-40 kHz
Input / Output Section	
Input Gain Range	±12 dB
Output Gain Range	±12 dB
Bypass Switch	Passive "hard-wire"
Metering	
Overload LED	+20 dBu
Inputs	
XLR and 1/4" TRS	RF Filtered, Active Balanced/Unbalanced
Outputs	
XLR and 1/4" TRS	Active Balanced

System Performance

Frequency Response	20 Hz-20 kHz (±0.5 dB)	
CMMR	65 dB (20-1 kHz, rising to 50 dB @ 20 kHz)	
Dynamic Range	120 dB (Noise floor-to-clipping into >2k Ω)	
THD+Noise	0.005 % (+4 dBu, 20-20 kHz, 80 kHz Bandwidth)	
Signal-to-Noise Ratio	98 dB (+4 dBu, 20 to 20k Hz Boost/Cut centered, unity gain)	

Input Specs	Impedance	Max Input Level
XLR & 1/4" TRS	6.6k Ω	+23 dBu
Output Specs	Impedance	Max Input Level
XLR & 1/4" TRS	200 Ω	+22 dBu (> 600 ohms)

RANE

GE 215/GE 130

Dual Channel 2/3 Octave and Single Channel 1/3 Octave Graphic Equalizers

The 2RU GE 215 dual 15-band and GE130 single 30-band graphic equalizers each feature Rane's innovative constant-Q (constant bandwidth) design which guarantees that the bandwidth of each filter is narrow enough to prevent unwanted interaction between filters, yet wide enough to produce exactly the type of correction curve required to control even the most unusual acoustical environment. Each active filter band features a boost/cut range of +12/-15dB on rugged 45 mm filter slider controls. Additional front panel controls and indicators, include an overall input level control, overload LED indicators as well as fail-safe hardwire bypass switches for each channel. The rear of the unit provides both active balanced XLR as well as Euroblock screw terminal inputs and outputs.

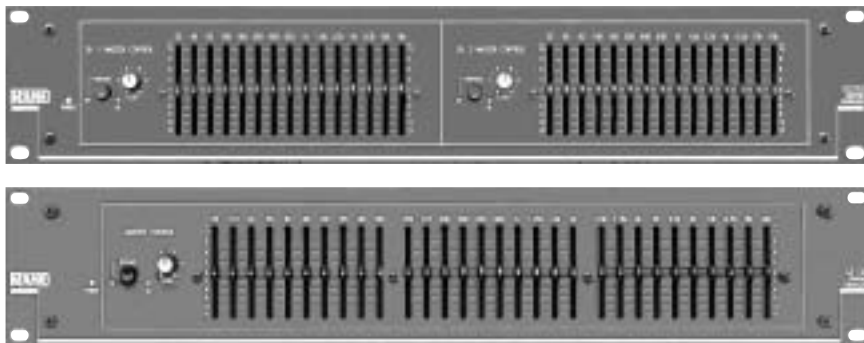

EQ Section

- ◆ Dual channel, 15-band and single channel 30-band graphic EQs — frequency bands located on standard ISO center frequencies
- ◆ Constant-Q filter design minimizes interactions between adjacent bands
- ◆ +12/-15 dB boost/cut range
- ◆ 45 mm filter slider controls with grounded center detents and dust dams

Inputs and Outputs

- ◆ Fully active balanced XLR and Euroblock terminal inputs and outputs

Additional Features

- ◆ Input level control and overload indicators for each channel
- ◆ Built-in infrasonic and ultrasonic filters eliminate low-end rumble and RFI
- ◆ Hard-wire bypass switches are provided for each channel allowing direct comparison between the equalized and non-equalized signal – these switches require no power to operate, and provide automatic bypass in case of power failure.
- ◆ Output relays provide a brief turn-on delay, eliminating power-up thumps
- ◆ 2 RU high and only 5" deep
- ◆ UL/CSA/CE and 100/120/230 VAC remote power supplies
- ◆ Constructed from cold-rolled steel

Equalizer Section	
Frequency Range	25 Hz to 16 kHz
Accuracy	3% from center frequency
Type	Constant Q
Boost/Cut Range	+12 dB / -15 dB Cut
Faders	45mm sliders, grounded center detent
Output Section	
Overall Gain Range	Off to 0dB (Unbalanced) Off to +6dB (Balanced)
Bypass Switches	Hard-wire fail-safe design
Built-In Filters	
Infrasonic Filter	20 Hz, 18 dB/Oct., Butterworth
Ultrasonic Filter	RF Interference
Metering	
Overload LED	3 dB below clipping
XLR & Euroblock Inputs and Outputs	
Inputs	RF Filtered, active balanced / unbalanced
Outputs	Active balanced / unbalanced

System Performance

Frequency Response	20-140 kHz (+0/-3 dB)
THD+Noise	0.009 % (+4 dBu, 20-20 kHz)
IM Distortion (SMPTE)	0.005 % (60 Hz/7 kHz, 4:1, +4 dBu)
Signal-to-Noise Ratio	(re +20 dBu/+4 dBu) 110/94 dB Sliders centered, unity gain, bal. 93/77 dB Full boost, unity gain, bal.
Channel Separation	90 dB (typical @ 1 kHz)

Note: 0 dBu = 0.775 Vrms

Inputs	Impedance	Max Input Level
XLR & Euroblock	20k Ω bal.	22 dBu
XLR & Euroblock	10k Ω unbal.	22 dBu
Outputs	Impedance	Max Output Level
XLR & Euroblock	200 Ω bal.	+19 dBu
XLR & Euroblock	+21 dBu (2k Ω)	(600Ω)
XLR & Euroblock	100 Ω unbal.	+13 dBu
XLR & Euroblock	+15 dBu (2k Ω)	(600Ω)

Constant-Q Graphic EQ Design

Constant-Q graphic equalizers arose from the sound professional's need for greater control with less interaction than previously possible with proportional-Q equalizers. Truth in slider position became a requirement. The curve traced out by the slider positions on constant-Q designs indeed represents the actual changes to the frequency response. On proportional-Q designs they do not. Use a constant-Q graphic the same way as a proportional-Q graphic. Desired results are achieved quicker, with far less after-adjustment to the adjacent sliders thus, eliminating a phenomena Rane calls "equalizing the equalizer."

GE 30/GE 60

Single and Dual Channel 1/3-Octave Graphic Equalizers

The GE 30 single-channel and GE 60 dual channel, 1/3 octave graphic equalizers represent Rane's top of the line EQs recommended for studios and broadcast as well as the most demanding live sound reinforcement applications. They take the already professional capabilities and robustness of the GE 215 and 130 to the next level with added flexibility and advanced features. Both units feature long throw, 60 mm high resolution slide controls on each filter band, sweepable high and low band-limiting filters as well as switch-selectable

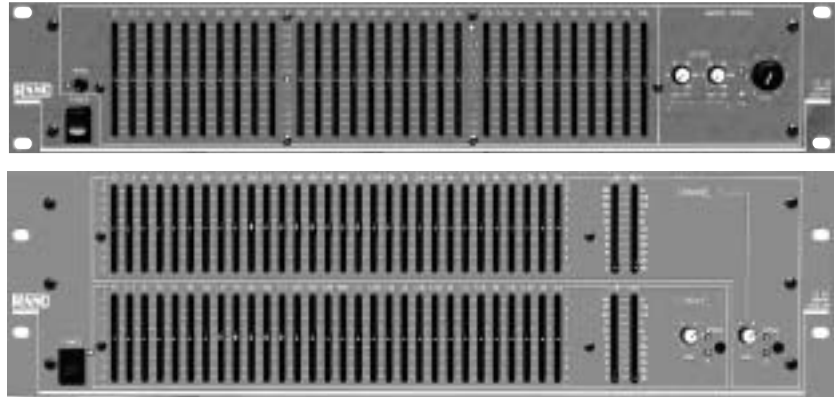

active balanced or transformer balanced XLR and screw terminal outputs that will ensure that any stubborn system ground problems can be eliminated. Another important feature is the use of Interpolating Constant-Q filters, which allow you to equally boost or cut two adjacent frequency bands and achieve a frequency peaks (or dips) that are in between the center frequencies of the filters. The GE 30 also adds the ability to choose between of boost/cut or cut only operating modes.

SAME FEATURES AND SPECIFICATIONS AS THE GE 215 AND GE 130 PLUS—

EQ Section

- ◆ 60 mm long throw, high resolution slide controls on each filter band with grounded center detents
- ◆ Dual operating modes (GE 30 only) — boost/cut and cut-only (switchable on the rear panel) allows your EQ choice to be made at the job site, instead of having to anticipate the requirements beforehand

Sweepable Band-Limiting Low Cut and High Cut Filters

- ◆ 12dB/oct sweepable filters from 10-250 Hz on the low end and from 3.1-40 kHz on the high end — restricting these signals can greatly improve system intelligibility

Inputs and Outputs

- ◆ RF balanced XLR and screw terminal inputs and outputs
- ◆ The GE 60 also provides balanced 1/4" TRS inputs and outputs
- ◆ A push button, on the rear panel, allows you to select active balanced or transformer coupled balanced outputs
- ◆ Signal ground and chassis ground terminals are also provided to ensure complete interconnect flexibility

Additional Features

- ◆ Overload and signal present LEDs
- ◆ Steel security panel included

Equalizer Section	
Frequency Range	25 Hz to 20 kHz
Type	Interpolating Constant Q
GE 60 Boost/Cut	±12dB
GE 30 Modes	Boost/Cut or Cut-Only
Boost/Cut Range	+12 dB / -15 dB Cut
Cut Only	-20dB
Faders	60mm sliders, grounded center detent
Output Section	
Overall Gain Range	Off to +6dB (Balanced)
Sweepable Filters	
Low Cut Filter	10 Hz-250 Hz, 12 dB/octave
High Cut Filter	3.1 kHz-40 kHz, 12 dB/octave
LED Metering	
Overload	20 dBu (Output or any internal level)
Signal Present	-20 dBu (Input level)

System Performance

	GE 30	GE 60
Frequency Response +0/-3 dB	10 Hz - 40 kHz	10 Hz - 40 kHz
THD+Noise (+4 dBu, 20-20 kHz)	0.015 %	0.009 %
IM Distortion (SMPTE) (60 Hz/7 kHz, 4:1, +4 dBu)	0.008 %	0.005 %
S/N Ratio (re +20 dBu/+4 dBu) Sliders @ 0 dB, max gain	111/95 dB (Boost/Cut Mode) 104/88dB (Cut-Only Mode)	115/95 dB
Channel Separation	—	75 dB (1 kHz)
Common Mode Rejection	—	40 dB 1 kHz

Note: 0 dBu = 0.775 Vrms

GE30 Inputs	Impedance	Max Input Level
XLR & Screw Term.	10k Ω bal.	22 dBu
GE30 Outputs	Impedance	Max Output Level
XLR & Screw Term.	200 Ω bal.	+24 dBu (600Ω)
GE60 Inputs	Impedance	Max Input Level
XLR, S.T, 1/4" TRS	20k Ω bal.	21 dBu
GE60 Outputs	Impedance	Max Output Level
XLR, S.T, 1/4" TRS	200 Ω bal.	+22 dBu (600Ω)

ME 15B/ME 30B/ME 60

microGraphic Equalizers

The Rane ME Series microGraphic Equalizers exist for people requiring the best equalizer value possible in the smallest space allowable. They offer the same high quality constant-Q performance as their long throw relatives, the GE's. No compromises or trade-offs exist in selecting the microGraphics — Only the slider throw is different. All circuitry, components and specifications are essentially identical. The

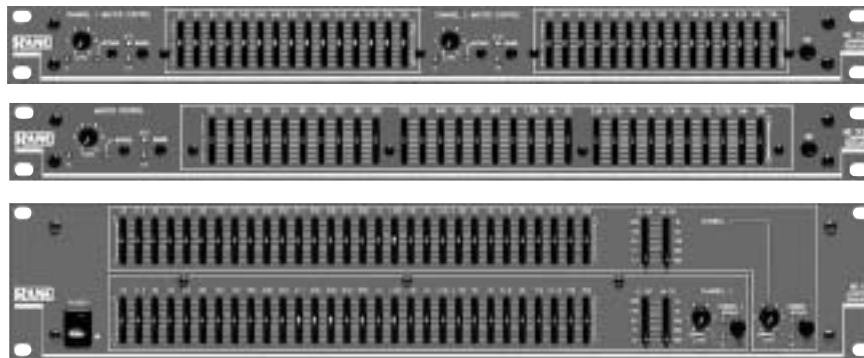

microGraphic series consists of three models — the ME 15B dual channel, 15-band 2/3-octave and the ME 30B, single channel 30-band 1/3-octave are housed in single space rack mount enclosures and feature a range switch that allows you to choose between ± 12 dB and ± 6 dB boost/cut. The ME 60 is a dual channel 30-band 1/3-octave model housed in a two space rack mount chassis that inherits the Interpolating Constant-Q design of its big brothers the GE 30 and the GE 60.

They All Feature

- ◆ Constant-Q design minimizes interactions between adjacent bands eliminating the need to “equalize the equalizer”
- ◆ Compact 20 mm sliders with dust dams detented and positively grounded at 0 dB
- ◆ The boost/cut range is switchable between ± 6 dB and ± 12 dB — The ± 6 dB mode offers the highest slider resolution while the ± 12 dB mode provides a wider range of control over system audio (ME 15B & 30B only)

Filters

- ◆ Built-in infrasonic and ultrasonic filters eliminate low-end rumble and RFI

Inputs and Outputs

- ◆ Active balanced XLR input and outputs are provided for working with balanced only signals
- ◆ Active balanced 1/4" TRS inputs and outputs are also provided for working with balanced or unbalanced signals

ME 60 Adds

- ◆ The same Interpolating Constant-Q design as the GE 30 and GE 60
- ◆ Sweepable High and Low Cut band limiting Filters
- ◆ Unbalanced RCA inputs and outputs

System Performance

Note: 0 dBu = 0.775 Vrms

	ME 15B / ME 30B	ME 60
Frequency Response (+0/-3dB)	20 Hz -100 kHz	20 Hz -40 kHz
THD+Noise (+4 dBu, 20-20 kHz)	0.015 %	0.008 %
IM Distortion (SMPTE) [60 Hz/7 kHz, 4:1, +4 dBu]	0.01 %	0.005 %
S/N Ratio (re +20 dBu/+4 dBu) [Sliders centered, unity gain, bal.]	107/91 dB	112 / 96 dB
Channel Separation (1kHz)	85 dB (ME 15B)	75 dB
Common Mode Rejection (1kHz)	40dB	46dB

		ME 15B / ME 30B	ME 60
Inputs	Impedance	Max Input Level	Max Input Level
XLR & 1/4" TRS	20k Ω bal./10k Ω unbal.	20 dBu/20 dBu	21 dBu
Outputs	Impedance	Max Output Level	Max Output Level
XLR & 1/4" TRS	200 Ω bal.	+19 dBu (600 Ω)	+19 dBu (600 Ω)
XLR & 1/4" TRS	100 Ω unbal.	+13 dBu (600 Ω)	+13 dBu (600 Ω)

Equalizer Section	
Bands	
ME 15B	Dual (15) 2/3-octave ISO spacing
ME 30B	(30) 1/3-octave ISO spacing
ME 60	Dual (30) 1/3-octave ISO spacing
Frequency Range	From 25 Hz to 16 kHz
Accuracy	3% from center frequency
Type	Constant Q
Boost/Cut Range	± 12 or ± 6 dB switch selectable (ME 60 ± 6 dB only)
Fader Travel	20mm sliders, grounded center detent
Output Section	
Overall Gain Range	Off to +0dB (Unbalanced) Off to +6dB (Balanced)
Bypass Switch	Hard-wire fail-safe design Auto-Bypass with power loss
Filters	
Infrasonic	20 Hz, 18 dB/octave, Butterworth
LED Metering	
Overload	4 dB Below clipping
XLR & 1/4" TRS Inputs & Outputs	
Inputs	RF Filtered, active balanced / unbalanced
Outputs	Active balanced / unbalanced
ME 60 ADDS	
Sweepable Filters	
Low Cut Filter	10 Hz-250 Hz, 12 dB/octave
High Cut Filter	3 kHz-40 kHz, 12 dB/octave
XLR, 1/4" TRS & RCA Inputs & Outputs	
Inputs	RF Filtered, active balanced / unbalanced
Outputs	Active balanced / unbalanced

SEQ 30S • SEQ 30L

Stereo Graphic Equalizers

The SEQ 30S and SEQ 30L are professional 30-band stereo graphic equalizers that use a single set of sliders to control the left and right channels simultaneously offering the ultimate in ease of use and stereo accuracy. Both units have exactly the same features and specs except that the SEQ 30S is a single space rack unit with 20 mm short-throw sliders, and the SEQ 30L is a dual space rack unit and employs 45mm long-throw sliders. Basic features include ± 12 dB boost/cut, input level controls, signal present and overload metering as well as XLR and 1/4" inputs and outputs.

30-band 1/3 octave Stereo Equalizers

- ◆ SEQ 30S uses short space-saving 20 mm sliders while the SEQ 30L uses long and more precise 45 mm sliders — all other features are identical
- ◆ A single set of faders controls the left and right channels simultaneously, maintaining true stereo tracking
- ◆ Fills the void for true stereo applications while delivering precise equalization down to a fraction of a dB
- ◆ A ± 12 dB input level control is provided along with a bypass switch, enabling easy gain comparisons between equalized and unequalized signal

Inputs and Outputs

- ◆ Balanced XLR inputs and outputs are provided as well as balanced 1/4" TRS inputs and unbalanced 1/4" TS outputs
- ◆ The XLR and 1/4" TS outputs can be used simultaneously to drive two sources such as an amplifier and a recorder

Additional Features

- ◆ Both units use low noise toroid output transformers that provides a wide 115 dB dynamic range
- ◆ +4 dBu and overload indicators detect both input and post-EQ levels
- ◆ Internal power supply

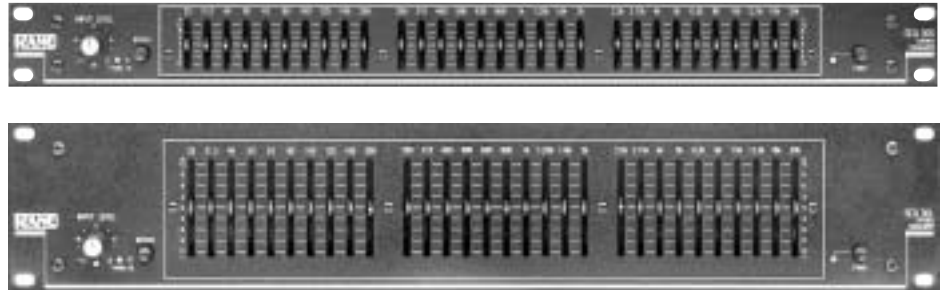

System Performance	
Frequency Response (+0/-3dB)	20 Hz -20 kHz
THD+Noise (+4 dBu, 20-20 kHz)	0.009 %
IM Distortion (SMPTE)	0.005 % (60 Hz/7 kHz, 4:1, +4 dBu)
Signal-to-Noise Ratio (re +4 dBu) (Sliders centered, unity gain, balanced)	96dB
Channel Separation (1kHz)	80dB
Common Mode Rejection (1kHz)	40dB

Note: 0 dBu = 0.775 Vrms

Inputs	Impedance	Maximum Input Level
XLR & 1/4" TRS	20k Ω bal.	21 dBu
XLR & 1/4" TRS	10k Ω unbal.	20 dBu
Outputs	Impedance	Maximum Output Level
XLR	100 Ω bal.	+20 dBu (2k Ω)
1/4" TRS	100 Ω unbal.	+20 dBu (2k Ω)

Equalizer Section	
Bands	Dual (30) 1/3-octave ISO spacing
Frequency Range	From 25 Hz to 20 kHz
Accuracy	3% from center frequency
Type	Constant Q
Boost/Cut Range	± 12
SEQ 30S Fader Travel	20mm sliders
SEQ 30L Fader Travel	45mm sliders
Output Section	
Overall Gain Range	± 12 dB (sliders centered)
Bypass Switch	Hard-wire fail-safe design Auto-Bypass with power loss
LED Metering	
Signal Present	+4 dBu
Overload	Clipping indicator
XLR & 1/4" TRS Inputs and Outputs	
Inputs	RF Filtered, active balanced / unbalanced
Outputs	Active balanced / unbalanced

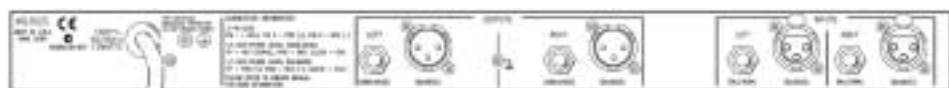

SEQ 30S rear illustration

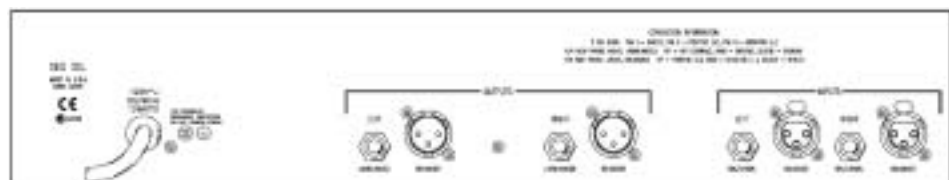

SEQ 30L rear illustration

RANE

AC 22 • AC 22B

Active Crossovers

The Rane AC 22 and AC 22B are both active crossovers configurable for stereo 2-way or mono 3-way

operation using state-variable 4th-order Linkwitz-Riley filter alignments designed to minimize phase difficulties in the critical crossover regions. The model AC 22 utilizes 1/4" TRS connectors with balanced/unbalanced inputs and unbalanced outputs while the AC 22B uses XLR connectors with active balanced inputs and outputs. They both feature, variable input and output level controls, band mute switches as well as user-adjustable time delay circuits to ensure proper mechanical phase alignment of adjacent drivers.



They Both feature

- ◆ Two independent active crossover channels configurable as stereo 2-way or mono 3-way
- ◆ State-variable 4th-order Linkwitz-Riley filter alignments with 24 dB per octave slopes are employed to minimize phase difficulties in the critical crossover region
- ◆ Crossover frequencies are selected using a continuously variable control with 41 detents that provide mechanical reference of crossover settings

Automatic 2-Way/3-Way Configuration

- ◆ Both units are smart enough to know whether you want to run a 2-way stereo, or a single channel 3-way system by the way the plugs are inserted and how your system is to be configured — plugging a signal into the channel 1 input and nothing into the channel 2 input tells the unit that you are running a single channel system in mono 3-way mode, and therefore sets the unit up to be a single channel device

Time Delay (Correction) Circuits

- ◆ To ensure the mechanical and electrical phase alignment of adjacent drivers will be acoustically correct, adjustable time delay circuits are provided on the low (and mid when used in 3-way mode) outputs of each channel to compensate for any physical misalignment of the drivers
- ◆ The low delay circuit can be internally "transplanted" to the high output when necessary

Stereo 2-Way mode

- ◆ A mono sub mode switch on the rear panel, allows you to disconnect the channel 2 low output jack and sum it with the channel 1 low output jack

Band Limiting Filters

- ◆ Built-in 18 dB/octave low cut filters at 20Hz virtually eliminates infrasonic rumble while provided overall system protection

Inputs and Outputs

- ◆ Both units features two inputs, to allow stereo operation and four outputs configured as dual low and high outputs in 2-way stereo mode or low, mid and high in 3-way mode
- ◆ The model AC 22 utilizes 1/4" TRS connectors with balanced/unbalanced inputs and unbalanced outputs
- ◆ The AC 22B uses XLR connectors with active balanced inputs and outputs

Additional Features

- ◆ An internal CD horn equalization modification is possible allowing a constant directivity horn to cover the same area as a long throw horn. This modification should be made by an experienced technician



AC 22

Inputs 1/4" TRS	Impedance 20k Ω bal.	Max Input Level 21 dBu
Outputs 1/4" TS	Impedance 100 Ω unbal.	Max Output Level +20 dBu (≥ 600Ω)

AC 22B

Inputs XLR	Impedance 20k Ω bal.	Max Input Level 21 dBu
Outputs 1/4" TS	Impedance 200 Ω bal.	Max Output Level +20 dBu (≥ 600Ω)

System Performance

Frequency Response	20 Hz -40 kHz +0/-3 dB
THD+Noise	0.02 % (+4 dBu, 20-20 kHz)
IM Distortion (SMPTE)	0.005 % (60 Hz/7 kHz, 4:1, +4 dBu)
Signal-to-Noise Ratio	92 dB (re +4 dBu, 20 kHz noise bandwidth)
Channel Separation	75 dB (1 kHz)
Common Mode Rejection	46dB (1 kHz)

Note: 0 dBu = 0.775 Vrms

Crossover	
Alignment	Linkwitz-Riley Proprietary 4th-order state-variable
Slopes	24 dB/octave
Range	70Hz - 3.6 kHz Low to High 41-detent continuously variable pot
Time Delay	Off to +2ms
Adjust Range	Low & mid outputs
Band Muting Switches	Low & mid outputs
Band Limiting Filters	
Infrasonic Filter	20 Hz, 18 dB/oct., Butterworth
Ultrasonic (AC22)	40 kHz, 6 dB/oct., Bessel
Gain Controls	
Input Gain Range	Off to +6 dB
Output Gain Range	Off to +6 dB (AC 22) Off to +12 dB (AC 22B)
AC 22 Inputs & Outputs	
1/4" TRS inputs	RF Filtered, Active Bal/Unbal
1/4" TS outputs	Active Unbalanced
AC 22B Inputs & Outputs	
XLR	RF Filtered, Active Balanced
XLR	Active Balanced



Active Crossovers

The Rane AC 23 and AC 23B active crossovers with identical features and specs as the AC 22 and AC 22B but

with the ability to be configured for stereo 2- or 3-way, or mono 4- or 5-way operation. The AC23, like the AC 22 is available with 1/4" TRS balanced/unbalanced inputs and 1/4" TS unbalanced outputs while the AC 23B is provided with XLR connectors with active balanced inputs and outputs.



System Performance

Frequency Response	20 Hz -40 kHz +0/-3 dB
THD+Noise	0.02 % (+4 dBu, 20-20 kHz)
IM Distortion (SMPTE)	0.002 % (60 Hz/7 kHz, 4:1, +4 dBu)
Signal-to-Noise Ratio	92 dB (re +4 dBu, 20 kHz noise bandwidth)
Channel Separation	75 dB (1 kHz)
Common Mode Rejection	46dB (1 kHz)

Note: 0 dBu = 0.775 Vrms

AC 23

Inputs	Impedance	Max Input Level
1/4" TRS	20k Ω bal.	21 dBu
Outputs	Impedance	Max Output Level
1/4" TS	100 Ω unbal.	+20 dBu (≥ 600Ω)

AC 23B

Inputs	Impedance	Max Input Level
XLR	20k Ω bal.	21 dBu
Outputs	Impedance	Max Output Level
1/4" TS	200 Ω bal.	+20 dBu (≥ 600Ω)

Crossover

Alignment	Linkwitz-Riley Proprietary 4th-order state-variable
Slopes	24 dB/octave
Ranges	41-detent continuously variable pot
Range 3-Way	70-1 kHz Low to Mid
Range 3-Way	190-7 kHz Mid to High
Range 2-Way	190-7 kHz Low to High
Time Delay Adjust Range	Off to +2ms Low & Mid Outputs
Band Muting Switches	Low & Mid Outputs

Band Limiting Filters

Infrasonic Filter	20 Hz, 18 dB/oct., Butterworth
Ultrasonic	40 kHz, 18 dB/Oct, Bessel

Gain Controls

Input Gain Range	Off to +6 dB
Output Gain Range	Off to +6 dB (AC 22) Off to +12 dB (AC 22B)

AC 23 Inputs and Outputs

1/4" TRS inputs	RF Filtered, Active Bal/Unbal
1/4" TS Outputs	Floating Active Unbalanced

AC 23B Inputs and Outputs

XLR	RF Filtered, Active Balanced
XLR	Active Balanced

Choosing the Right Configuration:

Mono, Two-Channel Mono or Stereo?

Very few systems indeed will utilize a two channel crossover for the purpose of true stereo imaging. Discrete stereo channels which are run from the mixing board are usually used for panning effects and/or for separate equalization of left and right speaker stacks. Different sides of the room often require significantly different equalization due to varying room acoustics, dimensions, positioning of speaker stacks near walls, curtains and the like.

Even though you may not plan to use stereo equalization or panning effects, it is recommended that your system utilize discrete crossover channels for each stack of speakers to ensure flexibility and control for consistent, optimum sound quality. For example, if you plan to run a multi-stack system mono three-way, use the AC 23 rather than the AC 22 for separate control over each set of speakers—especially since phase alignment may differ with each stack requiring separate time delay adjustments. Even with only a single system equalizer, the AC 23 can deliver the extra independent control which can make a difference in sound throughout the listening area. If all drivers are built into a single cabinet, or you are running bi-amped monitors, then the AC 22 is the one for you.



Linkwitz-Riley Alignment

Simply put, a Linkwitz-Riley alignment is two cascaded 2nd-order Butterworth filters exhibiting identical phase characteristics on their Low pass and High pass Outputs. This guarantees in-phase outputs at all frequencies, mandatory for proper acoustic summing of common signals from adjacent drivers in the crossover region. An added benefit of this topology is steep 24 dB per octave rolloff slopes. A slope of this magnitude guarantees drivers designed to produce a specific range of frequencies, and no more, will not be driven past their limits, thereby minimizing distortion and driver fatigue.

SAC 22 • SAC 23

Stereo 2-Way and Stereo 3-Way Crossovers

The SAC 22 and SAC 23 employ the same state-variable 4th-order

Linkwitz-Riley filters with steep 24 dB per octave rolloff slopes, as the

AC22 and AC23 ensuring identical phase characteristics on its low pass

and high pass outputs. The SAC 22

utilizes a single 31-position precision DC control voltage potentiometer to simultaneously select the low and high frequency

points while the SAC 23 uses two 31-position controls divided between low/mid and mid/high crossover regions. This

crossover circuit design provides a smart and easy way to biamp or triamp your audio system while at the same time ensuring consistent accuracy from channel-to-channel and unit-to-unit that provides a distinct advantage over continuously

variable designs using ganged potentiometers which can yield large variations in channel-to-channel matching. Both units also feature active balanced XLR inputs and outputs.



They Both Feature

- ◆ 31-position detented stereo crossover controls provide the simplest way to biamp (SAC 22) or triamp (SAC 23) your system
- ◆ Same 4th order Linkwitz-Riley crossover design as the AC22/23
- ◆ An input level control allows decreasing the overall sensitivity of the entire sound system, including the mono subwoofer if one is used
- ◆ Separate low, high and mono subwoofer output level controls allow compensation for sensitivity variations in amplifiers and drivers

Inputs and Outputs

- ◆ Separate balanced XLR connectors are provided for the left and right inputs as well as the stereo low and high outputs. Additional left and right XLRs are provided for the mid outputs of the SAC 23

Subwoofer Output

- ◆ The mono subwoofer output, with a switchable 100 Hz Low Pass Filter, provides a separate mono sum of the left and right low outputs
- ◆ The subwoofer output may be used along with the left and right low outputs

System Performance

Frequency Response	15 Hz-40 kHz +0/-3 dB
THD+Noise	0.1 % typical +4 dBu, pass band
IM Distortion (SMPTE)	0.02 % (60 Hz/7 kHz, 4:1, +4 dBu)
S/N Ratio	84 dB minimum (Max. gain re +4 dBu, 20 kHz BW)

Note: 0 dBu = 0.775 Vrms

Inputs	Impedance	Max Input Level
XLR	20k Ω bal.	+20 dBu
Outputs	Impedance	Max Output Level
XLR	100 Ω unbal.	+20 dBu (2k Ω)



SAC 22 rear illustration

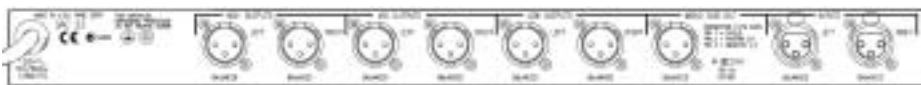

SAC 23 rear illustration

Crossover	
Alignment	Linkwitz-Riley Proprietary 4th-order state-variable
Slope	24 dB/octave
Range Control	Stereo 31-detent continuously variable DC
SAC 22 Range	100 Hz-3.2 kHz
SAC 23 Low/Mid Range	80 Hz-1 kHz
SAC 23 Mid/High Range	350 Hz-7 kHz
Tracking	2 % Channel-to-channel tracking error
Frequency Selector Accuracy	10 % max.
Gain Controls	
Input Gain Range	Off to +6 dB
Output Gain Range	Off to 0 dB
Mono Sub	
Low Pass Filter	100 Hz, 12 dB/octave 3rd-order Butterworth
Gain Trim	Off to +0 dB
Band Limiting Filters	
Infrasonic Filter	15 Hz, 18 dB/Octave Butterworth
Ultrasonic	40 kHz, 18 dB/Oct, Bessel
Indicators	
Green Signal Present LED	+4 dBu
Red OverLoad LED	3 dB Before Clipping
Inputs & Outputs	
XLR Inputs	RF Filtered, Active Balanced
XLR Outputs	Active Balanced

30-Band Multi-Function Realtime Analyzer

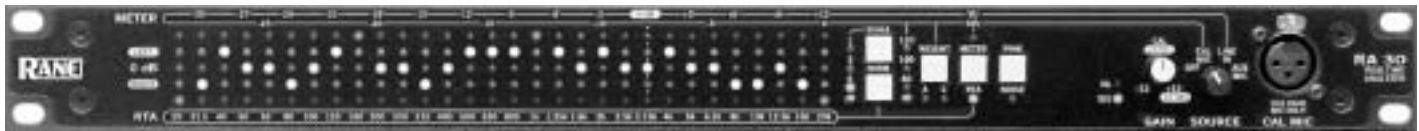

Real Time Analyzer Mode



Sound Pressure Level Mode



Stereo VU Mode

The Rane RA 30 Realtime Analyzer is a single rack space unit providing 30 bands of realtime frequency/amplitude information in a 5-LED per band format. The RA 30 serves three functions: Realtime Analyzer with Pink Noise generator, SPL Meter and Stereo VU Meter with Peak Hold.

RTA

(Real Time Analyzer) Mode

- ◆ RTA Mode allows you to visually judge the character of the signal being generated by the built-in Pink Noise generator (or any sound) using the included measurement microphone. You are then able to adjust an external 1/3-octave equalizer for the optimum response of a sound system based on the readings presented by the LED display.
- ◆ RTA mode divides broadband signals applied to either the mic or line inputs into 1/3-octave increments using IEC 61260 Class 2 filters. The outputs of the filters are displayed on the front panel to visually indicate the amplitude of each band, in user-selectable 1, 3 or 6 dB per LED scales.
- ◆ A Normalize button sets the 0 dB reference to the maximum band level.

SPL (Sound Pressure Level) Meter Mode

- ◆ Accurately displays SPL readings from a minimum of 51 dBA to a maximum of 120 dBA
- ◆ In SPL Meter Mode, the display is read horizontally and calibrated to a 1 dB resolution using the included calibration mic which auto ranges for maximized operation.
- ◆ A- or C-weighting filters are user selectable.

Stereo VU Meter Mode

- ◆ Stereo VU mode is automatically enabled when the Line input source is selected
- ◆ Levels are displayed as two horizontal rows of yellow LEDs with a 1.5dB resolution: The top row corresponds to the Left Input, and the bottom row corresponds to the Right Input. Levels above +3 dB on the VU scale switch to the red LED rows.
- ◆ The VU can be calibrated to accommodate +4 dBu or -10 dBV signals.
- ◆ An instantaneous Peak Hold function with a 2-second hold time is also provided using a single LED display for each channel
- ◆ Peak Hold is enabled or disabled by pressing the NORM button.
- ◆ If the held peak value is greater than +12 dB on the VU scale, the +12 dB LEDs stay illuminated. In this case, the Input gain can be decreased until the peak value is not "stuck" at +12 dB. For a calibrated peak measurement, the input gain can be set to minimum, which sets the 0 dB mark on the VU scale to +16 dBu.

MIC 2 Condenser Microphone

A professional quality back-electret condenser microphone with an omnidirectional pick-up pattern. This microphone is supplied with each RA 30, and connects to the front panel Mic Input jack only. The tapered aluminum mic housing fits most mic stand clips (one is included), and comes complete with a 25 foot (7.6 meter) cable to facilitate distant placement of the mic from the analyzer. These factory tested mics are flat to within 1 dB from 20 Hz to 16 kHz. An Aux Mic Input is provided on the rear panel, facilitating the use of other microphones.



MIC 2 Condenser Microphone

Rear Panel

- ◆ Pink Noise Output jack with a recessed Pink Noise Level adjustment
- ◆ Aux Mic Input (XLR)
- ◆ Stereo Line Inputs (1/4" balanced, can operate in mono by using the left input only).

SAMSON

S•COM / S•COM PLUS

Stereo Compressor / Limiters

The S•com is a dual-channel, single rack space stereo compressor designed to control signal levels in a variety of applications. Its logical design and layout make it simple to understand and easy to use. Sonic integrity

offers clean, distortion free audio, and a predictable, usable range of control from undetectable to clearly identifiable. Each channel combines an Expander/Gate, a Compressor/Limiter and a fully adjustable Enhancer. This unique circuit reduces noise, increases loudness and recovers high frequencies that might otherwise be compromised when audio is heavily compressed. The Spectra switch adds a mid-band boost to the detector circuit to help smooth out harsh vocals.

The S•com PLUS has basically the same features, but also offers a variable de-esser to improve audio quality by removing "S" from vocals and sibilance from overly bright sources such as cymbals. Both include a three-year extended warranty.



FEATURES

Expander/Gate

- ◆ The Expander/Gate features a variable Threshold control and switchable (fast/slow) Release time.
- ◆ Twin (open and closed) LEDs provide visual confirmation of the gate's operation

Compressor / Limiter

- ◆ Compressor/Limiter controls include variable threshold, ratio, attack, release and output level.
- ◆ Switchable AEG (Auto Envelope Generator) function continuously analyzes the audio input, and automatically adjusts the attack and release times based on the changing level.
- ◆ EFR (Enhanced Frequency Recovery) circuit helps restore high frequency content that can be lost when high gain reduction is applied.
- ◆ The SKD (Smart Knee Detector) automatically chooses between hard or soft knee compression curve—based on the program material. A hard knee curve activates the compression circuit only when the audio signal exceeds the threshold vs. a soft knee curve which gradually increases the compression ratio until the threshold is met.

Metering

- ◆ 12-segment LED meter is provided for Gain Reduction levels
- ◆ Another 12-segment LED meter can be switched to display input or output levels

Inputs and Outputs



- ◆ Servo balanced inputs and outputs on XLR and 1/4" connectors with switchable +4 and -10 operating levels.
- ◆ 1/4" key inputs and outputs

Additional Features

- ◆ A Key input switch, allows you to use an external audio source to control processing. For example, the signal from a kick drum trigger the amount of compression applied to a bass or you can use an EQ to specify which frequencies should be used to control dynamics.
- ◆ A link switch allows true stereo operation with channel one controlling the processing of both channels.

S•COM Only

- ◆ A Key Listen feature allows you to audition the Key input signal.
- ◆ An Enhancer level control allows you to adjust the amount of Enhanced Frequency Recovery being applied to the signal
- ◆ In lieu of a dedicated de-esser, a switchable Spectra circuit allows you to add a mid-band boost to the detector circuit to tame sibilant vocals

S•COM PLUS Only

- ◆ A switchable de-esser circuit with variable level control, helps you tame harsh and sibilant vocals. A five segment LED meter shows you the amount of high frequency gain reduction being applied to the signal
- ◆ A dedicated Peak Limiter ensures that output levels do not exceed the desired threshold level. Ideal for speaker protection in your PA rig and for recording and mixdown, especially to digital devices. An LED lets you know when the threshold level has been exceeded and the Limiter circuit is activated.

SAMSON

S•COM 4 / S•GATE 4

Four Channel Dynamics Processors

Compact and versatile, the single-rack space S•Com 4 and S•Gate 4 each four channels of high quality dynamics processing at an affordable price. The S•Com 4 features an Expander/Gate and Compressor/Limiter on each channel while the S•Gate 4

features an Expander/Gate/Ducker on each channel. Both units feature balanced XLR and 1/4" inputs and outputs and have a link function that allows you to configure each unit to work as dual stereo processors.



S•Com 4

- ◆ 4 Channel Compressor/Limiter, Expander/Gate with Enhancer
- ◆ Individual Threshold and Ratio controls on each channel
- ◆ SKD (Smart Knee Detector) circuit automatically switches from soft to hard knee based on the level of input signal applied
- ◆ EFR (Enhanced Frequency Recovery) circuit helps restore high frequency content that can be lost when high gain reduction is applied.
- ◆ Expander/Gate circuit with variable Trigger control and switchable Fast/Slow Release
- ◆ 5-Segment LED meters provided for input/output levels and Gain Reduction on each channel

S•Gate 4

- ◆ Four channel Expander/Gate/Ducker
- ◆ Each of the gate channels has variable Threshold, Attack, Release, and Range controls
- ◆ Variable High and Low Pass Filters, on each channel, allow frequency selective triggering
- ◆ Ducker feature allows you to automatically attenuate (as opposed to gate) the signal of a channel or stereo pair.
- ◆ Ducking can also be triggered by an external audio source using the 1/4" Key Input. A Key Listen switch lets you monitor the key input signal.
- ◆ 8-segment LED meter lets you monitor the amount of Gain Reduction on each channel

Samson's S•Class processors represent a new perspective on professional-level audio processing. Elegant and powerful, they combine proven circuitry, innovative features and ease-of-use in beautifully crafted cabinets.

Both Feature

- ◆ Linkable in two stereo pairs. This allows the settings on channels 1 and 3 to control the processing of channels 2 and 4.
- ◆ Advanced circuit design utilizing low noise operational amps and high quality VCAs
- ◆ Servo balanced inputs/outputs on XLR and 1/4" connectors with switchable +4/ -10 operating levels.
- ◆ Three-year extended warranty

S•PATCH PLUS 48-Point Patch Bay



Fully balanced and extremely durable, the S•Patch PLUS is a 48-point patch bay that makes all your connections easy. Offers normal, half-normal and Through Mode operation via the 3-way front panel mode switch. Balanced 1/4" TRS connectors. 19" rackmountable chassis.

SAMSON

S•VOX

Stereo Voice Channel/Input Mixer

The S•Vox is a sophisticated stereo voice channel including a four input mixer with digital outputs. An ideal front-end device for hard disk recorders, the



S•Vox features two high quality microphone preamps with 3-band EQ, an optical compressor and convenient insert points. Also available on the mic channels are line inputs specially matched for guitar and bass guitar outputs. The S•Vox also features two independent line inputs, which are ideal for keyboards or for a sub-mix input. The extensive master section offers control room monitoring, as well as analog and S/PDIF digital outputs.

FEATURES

Channels 1 and 2

- ◆ Channels 1 & 2 feature high-quality microphone preamps with switchable 48v phantom power and Phase Reversal switch is also provided for advanced two channel miking techniques.
- ◆ A 3-band EQ with sweepable mids and an In/Out switch that provides clean and silent toggling between equalized and non-equalized modes.
- ◆ Channels 1 and 2 also feature an optical compressor with variable threshold which provides wide-ranging high quality control of signal dynamics.
- ◆ EFR (Enhanced Frequency Recovery) circuit helps restore high frequency content lost when high gain reduction is applied.
- ◆ Convenient insert points are also provided
- ◆ Two 5-segment LED meters show accurate information of input or output signals so all signal changes can be monitored.

Channels 3 & 4

- ◆ Channels 3 and four provide line inputs, with volume and pan controls, that can be used for keyboards and other processors or they can be used to return a stereo sub mix.

Inputs and Outputs

- ◆ XLR mic, 1/4" line combo connector inputs are provided on the front panel for channels one and two
- ◆ S/PDIF inputs and outputs allow you to connect the S•Vox digitally to your DAW

- ◆ 1/4" TRS balanced mixer outputs are also provided on the rear panel for analog recording

- ◆ Analog control room/headphone outputs can also be used to monitor the signal before or after it enters the DAW

S•ZONE Stereo Multi-zone Mixer



The perfect solution for multi-zone audio installations, the S•Zone is a 4-channel / 4-zone stereo mixer featuring two mic/stereo line inputs with ducking, two stereo CD/line inputs, on-board speaker and headphone monitoring. It also offers Euroblock output connectors and remote volume control. Great for controlling and monitoring audio in restaurants, bars, clubs, houses of worship and office or boardroom situations.

- ◆ 4 channel stereo zone splitter/mixer
- ◆ 4 balanced stereo zone outputs
- ◆ Unique front panel monitor section with selectable zone monitor switch, headphone output and built-in super-speaker
- ◆ 2 Stereo CD/Line inputs with backlit zone assignment switches
- ◆ 2 Mic/Stereo Line inputs with backlit zone assignment switches
- ◆ Phantom power available on mic inputs
- ◆ Independent, adjustable Zone ducking on microphone inputs 1 and 2
- ◆ Independent 2-band equalizer on each zone output
- ◆ All stereo inputs and outputs switchable to mono
- ◆ 6 segment LED output VU meters for each zone
- ◆ Euroblock screw-terminal input and output connectors
- ◆ Remote VCA volume control capability for each zone output
- ◆ Internal voltage-selectable power supply
- ◆ Standard EIA single rack space chassis

SAMSON

S•CURVE 215 / S•CURVE 131 / S•CURVE 231

Designed and built for professionals, S•Curve EQs feature easy to read LED displays and the extra features professionals need. S•Curve EQs are also exceptionally quiet, in fact up to 15dB lower than comparable EQs. Three models available, the S•Curve 215 is a great, multi-purpose EQ packed with features and easy-to-read lighted display. The S•Curve 131 is for pros looking for a full 31-band EQ, while the S•Curve 231 is a totally comprehensive, feature-rich dual 31-band EQ for the most demanding applications. They all feature Constant Q circuitry, balanced XLR and 1/4" TRS inputs and outputs, LED faders and LED bar VU meters, boost/cut and cut only modes, and a bypass switch

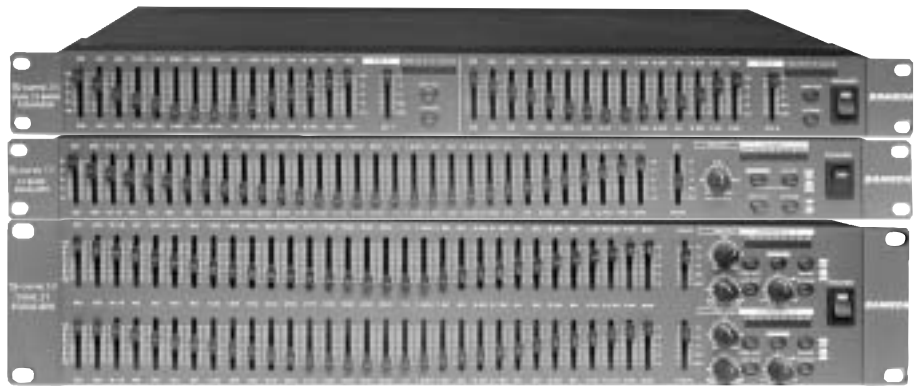

PROCESSORS

319

S•Curve 215

Dual 15 Band Graphic EQ

- ◆ 2/3 octave 15 band stereo graphic equalizer
- ◆ High pass filter
- ◆ Single rack space chassis with aluminum extrusion face plate

S•Curve 131

Dual 15 Band Graphic EQ

- ◆ 1/3 octave 31 band graphic equalizer
- ◆ Variable Low cut filter
- ◆ Single rack space chassis with aluminum extrusion face plate

S•Curve 231

Dual 31 Band Graphic EQ

- ◆ 1/3 octave 31 band stereo graphic equalizer
- ◆ Switchable $\pm 6\text{dB}$ or $\pm 12\text{dB}$ filters
- ◆ Variable Low and High cut filters
- ◆ Double rack space chassis with aluminum extrusion face plate
- ◆ Subwoofer output

S•3-WAY Stereo/Mono Crossover

The S•3-way is a versatile 2-way, 3-way and 4-way crossover with a difference. First, it's a perfect 2-way or 3-way stereo crossover. But its mode is also switchable for use as a 4-way mono crossover. Both feature 2ms of delay for time alignment, Mute and Phases switches for each output and XLR balanced outputs.



- ◆ Full-featured, Stereo 3-way, Mono 4-way electronic crossover
- ◆ The input gain features $\pm 12\text{dB}$ range with LED metering and Peak indicators.
- ◆ The first crossover point is sweepable in three ranges from 35Hz to 800Hz, from 350Hz to 8kHz with the 10X-Multiplier switch engaged, or from 16Hz to 400Hz in 4 way low-mode.
- ◆ The second crossover point is sweepable from 175Hz to 4kHz or from 350Hz to 8kHz depending on the setting of the mode switch.
- ◆ A Delay section with up to 2ms of delay to time-align low frequency outputs for improved phase response of any PA system
- ◆ Low, Mid and High Frequency outputs with $\pm 6\text{dB}$ of gain control.
- ◆ Each output incorporates a Mute switch for monitoring the individual frequency bands and a phase switch to invert the polarity of the output.
- ◆ High-quality 41-position detent pots and backlit switches
- ◆ The global section features a variable threshold Limiter, a CD function (for constant directivity horns) and High Pass Filter.

ORDER & INFO. (212) 444-5088 • FAX: (212) 239-7770 (800) 947-7008
1-800-875-6951 • www.bhphotovideo.com



SAMSON

C•CLASS SERIES

PROCESSORS

320

C•Class is audio gear designed to work seamlessly with your digital setup—but it works outside your computer. Each C•Class component is optimized for today's digital studio. When combined, C•Class components become an integrated suite of studio tools and effects. The "C" stands for compact. C•Class products bring the feel of analog equipment back to what has become a digital world. C•Class System integration features include ins and outs that are optimized for each other, new interlocking C•Class bumper-legs and cohesive industrial design.

Five processors in the C•Class series, the C•Valve is a tube preamp that adds the warmth of analog tubes to digital recordings; the C•Com 16 is a compact, full-featured compressor for the desktop; the C•Com Opti adds the magic of optical compression to recordings; the C•Control provides a control room matrix previously available only on consoles costing thousands; and the C•Que 8 is the perfect compact headphone amp.

FEATURES

C•Valve:

C•Valve is a tube mic/instrument preamp that will give you pure signal and silky sound up-front, where it counts. It features variable gain and variable tube process saturation for adding harmonics that give warmth to vocals and instruments. Regardless of which mic you use, it will maintain detail and transparency. 48-volt phantom power, phase and peak limiter round out the control set. A large analog VU output meter and a 6-segment LED input meter makes it easy to adjust the gain. Use its insert points along with a C•Class compressor for a direct path to a gorgeous front end sound. The C•Valve provides a digital output as well.

C•COM 16:

A Stereo Compressor/Limiter with 16 presets, the C•Com 16 gives you the fastest way to achieve useable dynamic control and the cleanest path for your audio. There are fifteen presets for the most standard situations and a manual mode for more critical adjustments when required. The C•Com 16's controls include variable threshold, ratio, attack, decay, release and output level. An enhancer provides the added character that is lost on heavy compression. Key output/input for outboard triggering or external filtering of the key signal. A 6-segment LED gain reduction meter and a 6-segment LED input/output meter provides visual monitoring of the circuit's affect.

C•COM Opti: Optical compressors are sought after for the distinctive musicality they give to vocals, guitars and other instruments. A perfect complement to the computer's hygienically clean makeup, the C•Com Opti's adjustable threshold, ratio, attack, release and output controls are calibrated to generate a distinctive soft, rich character while providing magnificent control over dynamics. An enhancer provides the added character that is lost on heavy compression. Key output/input for outboard triggering or external filtering of the key signal. Large analog VU meter for output level or gain reduction.

C•Control:

The C•Control is a control room matrix selector and a unique solution for studios with multiple monitors, headphone mixes and tape or digital sources. Provides easy, heretofore impossible to achieve, instant monitor mixes or dubs. Select from three pairs of speakers with dim and mute. Use the Talkback mic to give instructions to the musicians in the headphone mix. And push-to-talk for slates to tape or disk. Includes a headphone amp with level control for private listening. The C•Control provides three sets of stereo ins and outs with dubbing capability to three discrete outputs.

C•QUE 8:

Further enhancing your control in the studio is the C•Que 8, a 4-Channel Headphone Amplifier with eight outputs. Independent volume on each channel makes this a truly versatile headphone amplifier. A 6-segment LED indicator shows the output for each channel. There's a Main volume for overall level adjustment. An effective EQ shape circuit offers tone control of each channel and listeners can manage their own personalized mixes. Link outputs allow more than one C•Que 8 to be used when needed.



EQUIPMENT LEASING AVAILABLE

SAMSON

S•CLASS MINI PROCESSORS

The S•Class Mini processors offer advanced signal processing in incredibly durable, portable enclosures. Very affordable, the S•Class Minis are perfect for home, on the road, or as a quick fix to a house sound system.

Eight processors in the series, they include the S•Direct DI box, S•Monitor for personal monitoring on stage or in the studio, S•Mix miniature 5-channel mixer, S•Amp four channel headphone amplifier, S•Convert for interfacing and level matching consumer and professional audio equipment, S•Combine a 2 to 1 mic combiner, and S•Split a 1-in 3-out mic splitter. Last, the S•Phantom is a 2-channel 48v phantom power supply with two balanced XLR mic inputs and two balanced XLR mic outputs and an AC adapter included.

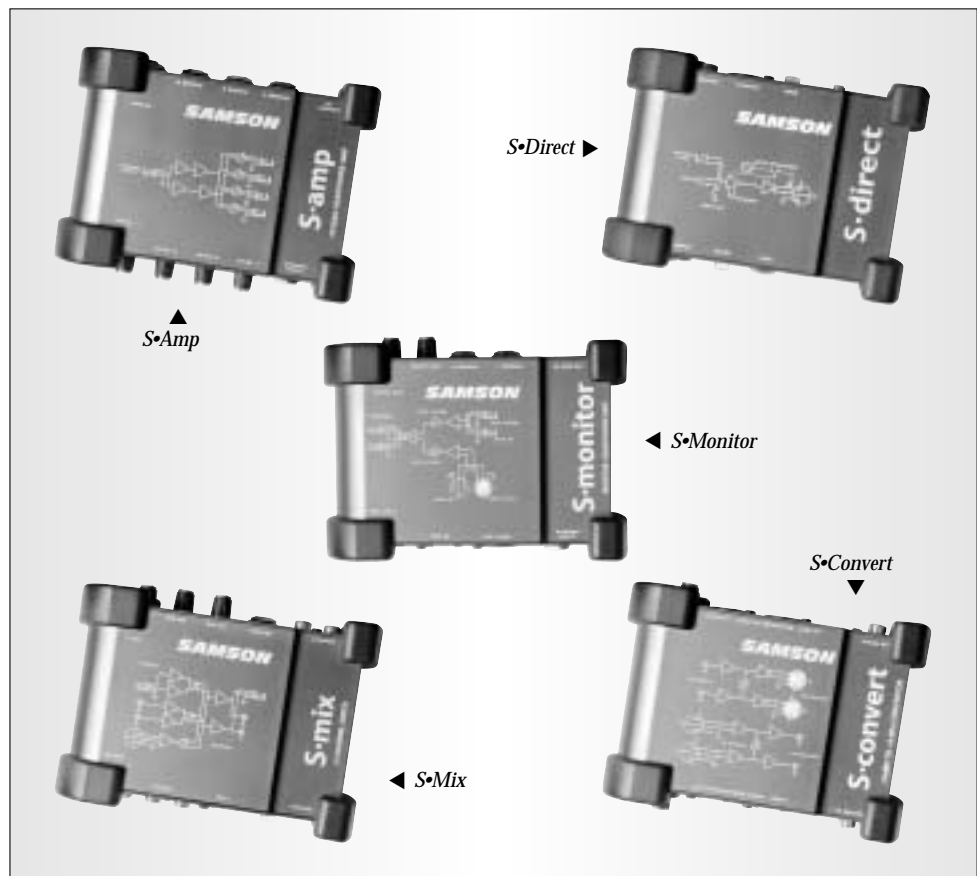

S•Combine

2 to 1 mic combiner, this tiny box has two balanced-XLR mic inputs, one balanced-XLR mic output and includes an AC adapter.

S•Monitor

Elegant solution for personal monitoring on stage or in the studio

- ◆ XLR microphone input
- ◆ XLR microphone Thru, mic output to send to main mixer
- ◆ 1/4" stereo mix input
- ◆ Mic and mix volume control
- ◆ 2 headphone outputs
- ◆ 1/4" mix Thru for daisy chaining additional units
- ◆ Includes 12v AC adapter

S•Direct

- ◆ Rugged and sturdy— ideal for stage and studio.
- ◆ Switchable input level handles instrument and speaker levels.
- ◆ 48v phantom power or 9v operation with auto battery shut off
- ◆ Switchable ground lift switch
- ◆ Gold-plated balanced XLR output
- ◆ 1/4" link output for stereo using 2 boxes

S•Split

1-in 3-out mic splitter with one balanced XLR mic input and three balanced XLR mic outputs. Transformer isolated output for clean signal. AC adapter included.

S•Mix

- ◆ Miniature 5-channel mixer
- ◆ XLR balanced mic input with volume control
- ◆ Stereo 1/4-inch and RCA inputs with volume control
- ◆ RCA + 1/4-inch stereo outputs
- ◆ Includes 12v AC adapter

S•Amp

- Four channel headphone amp ideal for home recording
- ◆ Four 1/4" stereo headphone outputs
 - ◆ Stereo 1/4" input
 - ◆ Individual volume control for each output
 - ◆ Includes 12v AC adapter

S•Phantom

The S•Phantom is a 2-channel 48-volt phantom power supply with two balanced XLR mic inputs, two balanced XLR mic outputs and includes an AC adapter.

S•Convert

A "bump-box", S•Convert is a problem solver for interfacing and level matching consumer and professional audio equipment

- ◆ +4 / -10 audio level converters
- ◆ +4 XLR/ -10 RCA inputs with level control
- ◆ +4 XLR/ -10 RCA outputs
- ◆ Includes 12v AC adapter

SYMMETRIX

421M

AGC-Leveler with Mic/Line Input



The 421M is a sophisticated audio gain controller—it makes quiet sounds louder and loud sounds quieter, just like a skilled audio engineer. Set the desired, “target” output level and the 421M gently boosts signals that drop below your target, and smoothly pulls back those that rise above it. Operation is automatic, precise, and completely transparent - no pumping or breathing.

The 421M is designed for installed sound systems, recording studios, broadcast facilities or any audio application where clarity and intelligibility are important. Since everybody speaks at different levels and works at varying distances from the microphone, intelligibility can vary from person to person or moment to moment. The 421M puts everyone on the same level. It is equally well suited to processing program material (for stereo applications two 421M's may be linked). Program levels from soundtracks, CD jukeboxes, or broadcast audio go up and down unpredictably. The 421M gently and unobtrusively raises the low level audio and compresses the high level audio without side effects. It's flexible input configuration will handle just about any audio source, from studio microphones to telephone-based paging systems.

How It Works

The 421M's Automatic Gain Control (AGC) section incorporates a smooth-acting leveling amp working with a make-up gain stage coupled to the ratio control. Increasing the ratio makes your program denser, but output level stays constant no matter what happens at the input. This means you could talk two feet from a mic and have the same volume output that you had at 6" (and vice versa).

To deal with program noise, the 421M has a full-featured downward expander section that effectively quiets the output when input signal is absent. A separate “brick wall” peak limiter provides speaker and overload prevention. Last but not least, switchable speech curve filters are incorporated to optimize the 421M for voice range performance.

The 421M is set apart by its “smart” circuitry. Other AGC designs confuse noise and feedback with the program signal, boosting noise or cutting off soft-spoken phrases. Not on the 421M. Proprietary Auto Release Monitor circuit instantly distinguishes between “real” signals (music/speech), noise and feedback.

Metering system makes it easy to setup and operate. Parallel LED displays show input compared to output so it is obvious if the 421M is adding gain or subtracting. Because you can hear and see the net results of the leveling action there is no more guess work.

421M Specifications:

Connectors

Line Inputs: 1/4" TRS jack and screw terminals, 20k Balanced Bridging

Mic Input: XLR, 10k Balanced Bridging

Outputs: XLR, screw terminals, 200 ohm source, Impedance, Differentially Balanced, +23 dBm maximum level TS phone, Unbalanced, +18 dBm maximum level

Bypass: Relay controlled, hard-wire bypass in power off and bypass conditions

Sidechain: TRS phone, unbalanced

Downward Expander

Ratio: 1:2

Threshold: -50VU (bypass) to -20VU (Auto)

Attack Time: 1 ms

Release Time: Program dependent, 0.3-3.5 seconds depending on amount and duration

AGC-Leveler

Ratio: 1:1 to 4:1

Auto Release Threshold: -70 dBu to -30 dBu

Attack Time: approximately 1 ms

Release Time: Program dependent, 500 ms - 5 sec. depending on amount and duration

Target Output

Range: +20 dB **Peak Limiter Ratio:** 10:1

Threshold: -15VU to +23VU (bypass)

Attack Time: 1 ms for 90% gain reduction

Release Time: 0.8 seconds

Mic Preamp

Gain Range: +15 dB to +45 dB

Impedance: 10k Ohms

Max Input Level: +8 dBu

THD+Noise: -85 dBu (gain control fully clockwise)

Phantom Power: 48-volt (±2)

Speech Curve

Type: Switch selected cutoff filters allow tailoring LF and/or HF response for speech applications

Frequencies: LF=125 Hz, 12 dB/octave; HF=6 kHz, 24 dB/octave

Input/Output Metering

Type: LED Bar Graph, 12 steps + clip

Range: (min to max) 66 dB

Stereo AGC-Leveler



Audio comes in all shapes and sizes. There's loud audio. There's quiet audio. There's pretty audio. There's ugly audio. There's music. There's speech. There are CD's mastered at drastically different levels. There are movie sound tracks where the effects are too loud and the dialog so soft you can't understand the words. Have you ever been on an airplane trying to watch the movie and found yourself repeatedly turning the volume up and down, up and down. Well, if you need to free yourself from unpredictable audio program levels then you need the 422 Stereo AGC/Leveler. With simple and intuitive controls, the 422 converts "all over the map" signal levels into smooth, intelligible, constant level audio. Unlike a compressor/limiter which only does half a job— it pushes down from the top, preventing overload and distortion in subsequent stages, but does nothing from the bottom (the low level signals that contribute so much to the intelligibility of speech and the enjoyment of music)—the 422 Stereo AGC-Leveler does it all. It makes the loud sounds quieter and the quiet sounds louder. And it does it with finesse. The 422 works without the side effects of compressors and limiters—no noise, pumping, and modulation.

FEATURES

Easy To Use, There Are Basically Only Four Controls

The 422 is a remarkably sophisticated volume controller that is amazingly easy to use:

- The first and most important is the target level control. This sets the volume where you want it. The 422's input over output parallel VU meters simultaneously show you the unmodified input signal on top and the result of your target level setting just below it.
- The detector control increases the sensitivity of the AGC. As you turn it counterclockwise the 422 gently reaches down for the lower volume audio and brings it up.
- Set the target level and detector, then use the ratio control to increase or decrease the amount of leveling. At high ratios the program density increase results in a more "present" or "up front" sound. At low ratios the 422 performs subtle, yet effective, automatic gain riding.
- Last, adjust the peak limit control to create an absolute ceiling level. This is very handy for protecting amps and speakers in discos where DJ's often succumb to a disease known as "volume creep" as the night wears on.

◆ Remote bypass port

Why Not Just Use A Compressor/Limiter?

When it comes to maintaining constant output levels, a compressor/ limiter can only do half the job, at best. Sure, when things get too loud the comp/limiter kicks in, but what about when things get too soft? A comp/limiter is a top down device –pushes down from the top, preventing overload and distortion in subsequent stages. But what about the bottom up part of the deal? What about the low level signals that contribute so much to the intelligibility of speech and the enjoyment of music?

The 422 brings the volume to where you want it and keeps it there. It can be used in virtually any type of sound system for processing just about any kind of audio. Insert the 422 at a convenient patch point where you have line level audio. There are no annoying -10, +4dBu level matching switches – just give the 422 a basic line (not mic level) signal and you're ready to go.

Input/Output

Inputs:	1/4" TRS and XLR Stereo, Balanced Bridging or Unbalanced
Outputs:	1/4" TRS and XLR Stereo, Balanced or Unbalanced
Polarity Input:	tip is high, ring is low, sleeve is ground
Output:	tip is high, ring is low, sleeve is ground
Max. Input Level:	+24 dBu
Max. Output Level:	+22 dBu into 600 Ohms

Performance

Frequency Response:	20 Hz - 20 kHz
THD+Noise:	05%
Dynamic Range:	>110 dB
Crosstalk:	-60 dB, +20 dBu in, 20Hz - 20kHz
AGC Detector Range:	-40 dBu to +24 dBu
Ratio:	1:1 to 5:1
Target Level Range:	30 dB
Limiter Threshold:	-15 dBu to +25 dBu
Limiter Ratio:	>15:1

SYMMETRIX

528E

Voice Processor (Channel Strip)



The 528E is a complete, self-contained voice processor with six separate functions: mic preamp, de-essing, compression/limiting, downward expansion, parametric EQ, and voice symmetry alignment. All six processors may be used simultaneously. Although the 528E is called a "Voice Processor", it is perfectly suitable for any signal, vocal or not. Each function features a full complement of controls in an easy-to-use layout. Separate LED meters monitor mic gain and dynamics gain reduction functions thus facilitating quick and accurate adjustment of controls.

Works with any mic (or line input), enhancing vocal intelligibility, increases perceived loudness and "presence". Great for voices as well as instruments and effects. Ideal for broadcast mics, voice-overs and music recording, and sound reinforcement for PA/Paging systems.

Mic Preamp

Variable gain up to 60dB and 48v phantom power. Switchable 15dB pad prevents distortion when close miking. Mic and line inputs are balanced-transformerless XLR and equipped with filters to prevent RFI.

Voice Symmetry

Corrects for excessive positive or negative signal peaks of the human voice. A simple in/out switch controls voice symmetry.

De-esser

Program controlled high-cut filter, 12 dB per octave senses and regulates selectable high frequencies to reduce or eliminate annoying sibilance and "lip smacking". Controls are frequency and range (800 Hz to 8000 Hz).

Compressor and Expander

The compressor/limiter maintains uniform levels while the downward expander eliminates "pumping", "breathing", and noise build up. And because it's program controlled, the 528E's dynamic range processor responds quickly to transients, and gently to smaller level changes. Controls are expand and compress threshold (-30 to 0 dBu) and compression/limiter ratio (1:1 to 10:1).

3-Band EQ

3-band— 16 to 500 Hz (Low), 160 to 6300 Hz (Mid) 680 Hz to 22 kHz (High) parametric EQ has a variable bandwidth from .3 octave to 4 octaves, 15 dB boost/cut, and overlapping frequency ranges. "Leap frog" topology minimizes the number of amps in the signal path while ensuring that each band interacts with its neighbor in a desirable and musical fashion.

Metering

- ◆ Type: Multi-segment LED bar graph
- ◆ Output Level: -20 to +3 VU (0 VU = +4 dBu), VU calibrated, peak responding
- ◆ Gain Reduction: separate displays for de-esser, downward expander, compressor
- ◆ 0 to 20 dB per display.

628 Digital Voice Processor



A digital version of the 528E, the 628 rolls a premium quality mic preamp, 20-bit A/D and D/A converters, de-esser, expander/gate, compressor and parametric EQ into a single rack space unit. Perfect for any voice and many other instruments or sounds the 628 combines proven digital signal processing and an easy to use analog-like interface with the power of 8 finely-tuned factory and 119 user-programmable presets. An optional RC-1 remote controller allows selection of the first eleven presets, plus a bypass function, eliminating frantic dashes to the equipment rack.

300 SERIES—Half Rack Audio Tools

Mic Preamp

The 628's first stage is a proprietary transformerless mic preamp incorporating filters to destroy radio frequency interference. A switchable 15 dB pad prevents overloading by hot condenser mics. A front panel LED indicates when phantom power is on. If you're into high end tube preamps then you can select line level input from the 628's front panel and bypass the 628's preamp.

De-esser

Tuning the 628's de-esser to the offending frequency minimizes overly bright sibilance without resorting to brute force equalization to solve the problem. The Threshold control lets you precisely apply this frequency selective gain reduction. LED metering displays the degree of de-esser action.

Expander/Gate

Independent Ratio and Release controls allow tuning of the expander/gate to fit any studio noise or performer isolation requirements. An LED meter shows the amount of downward expansion or gating taking place. Most compressors use a "one size fits all" approach to compression; the design of the 628 reflects the realization that voice and mixed music require different design philosophies. While the control complement is simple (threshold, ratio and release), each has been highly optimized for voice work. The result is a compressor that can tightly control gain (from hard compression to gentle level control) with no side effects.

3-Band Parametric EQ

Three overlapping bands of digital parametric equalization round out the processing power of the 628. The EQ can notch out interference, boost low frequency energy, cut mid-range grunge and brighten a muddy, dull voice simultaneously. The 628's parametric approach to equalization allows cuts and boosts exactly where needed to make every voice sound outstanding. Three 7-segment LEDs display all parameter values and preset numbers. An output level meter continuously monitors output. Selectable digital sample rates of 48, 44.1 and 32kHz. Balanced and unbalanced analog output as well as AES/EBU and S/PDIF digital outputs are provided.

302 Dual Mic Preamp

Designed for broadcast, sound reinforcement, and digital and analog recording. Offering substantial sonic improvements over



stock mixers or console preamps, the 302 has solid stereo imaging, excellent transient response, very low noise, and almost undetectable distortion.

- Polarity reversal switches and 15dB pads on both channels
- 48 volt phantom power
- Gain variable from 20-60dB, works with virtually any professional microphone.

303 Interface Amplifier (Bi-Directional)



A stereo level matching amplifier that accepts balanced or unbalanced inputs and converts them to balanced or unbalanced outputs.

Use the 303 to interface a consumer DAT, cassette recorder or computer sound card to a professional recording console or to other +4dBu nominal level equipment.

- Stereo XLR and RCA inputs and outputs
- External power supply ensures low noise

304 Headphone Amplifier

Stereo in, four output amp drives headphones of any impedance. Used in broadcast, installed sound, and recording applications.

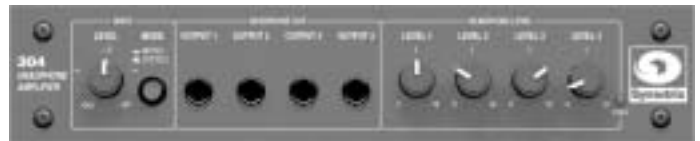

High voltage technology provides 6dB volume increase over most competing units. Compact half rack chassis permits 8 channels in one rack space.

- Individual volume controls for each output, master input volume
- Stereo or mono operation, balanced or unbalanced input
- Pass Thru jacks permit daisy-chaining of multiple units.

305 1x4 Distribution Amplifier



A one input/four output mono distribution amplifier. Use the 305 to route your most critical audio to four separate

outputs. Sound contractors will find the 305 essential for feeding multiple power amps. Broadcast engineers can easily and inexpensively distribute satellite audio around their station.

- Euroblock connectors for quick installation
- Four-segment LED input level meter
- Precision circuitry yields less than .009% THD+Noise
- Individual trim pots for input and output volume attenuation

TC ELECTRONIC

GOLD CHANNEL

Dual Channel Digitally Enhanced Mic Preamp



The Gold Channel is a two channel digitally enhanced mic preamp/processor that uses premium 24-bit A-D converters, a high resolution 24-bit 96kHz signal path and a full range of powerful refinement tools to capture the highest quality audio to any analog or digital recorder. Features include an expander/gate, Softlimiter, compressor/limiter, EQ and other specialized tools, all accessible through an easy to use channel strip interface with high resolution metering. Standard Mic/Line inputs are provided as well as AES/EBU, Toslink, S/PDIF and ADAT digital I/Os. 200 User Preset memory locations allow you to customize settings and store them for instant recall – a real time saver when working with specific musicians over several sessions. In addition to delivering a pristine preamplification, the Gold Channel can also be inserted into a console or DAW where it can be used to process recorded material in 96kHz resolution.

FEATURES

Auto Gain

- ◆ Plug in a mic, select Auto Gain and press Enter. Let the musician or vocalist perform and press Enter when finished. Auto Gain has now set the optimal gain level

Channel Overview

- ◆ Functions for each channel are on the front panel with a user friendly display:

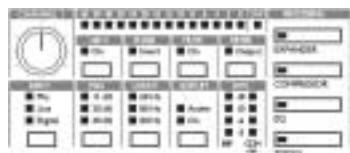

- Input Gain knob
- Input Select – Mic, Line, Digital
- Switchable +48V phantom, Phase Invert, Mute, Soft Clipper and Meter select
- PAD – 0dB, 20dB, 40dB
- Lo-Cut – 60Hz, 80Hz, 120Hz
- ◆ Separate bypass buttons are also provided for each processing block
- ◆ 14 segment LED meter is switchable between showing input and output right after the digital Master Output. Two 4 segment LED meters show gain reduction for the Expander and Compressor/Limiter

Inputs and Outputs

- ◆ Wordclock input (RCA)
- ◆ External control input
- ◆ Dual balanced XLR Mic/Line inputs and Line outputs with 24 bit A/D-D/A converters as well as AES/EBU, S/PDIF, Toslink and ADAT digital I/O – simultaneous multiple digital outputs is supported and can be dithered between 8 and 22 bits

Total and Partial Recall

- ◆ 100 factory, 200 user presets – you can also store up to 999 presets on a PCMCIA card
- ◆ Recall an entire preset or perform a Partial recall which enables you to load specific parts of a preset into the currently preset
- ◆ Instantly recall customized settings that match a specific instrument or vocalist

Four Processing Blocks

A variety of full featured dynamics, EQ and other specialized algorithms can be placed freely within any of four processing blocks available per channel. When using the 96kHz option, you can either use 1 channel and gain access to 3 blocks or use both channels with 1 block available per channel

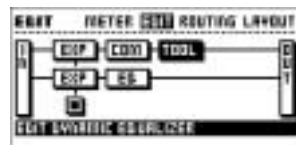

- ◆ Use either an over-easy Noise-Gate or a more comprehensive Expander with additional parameters
- ◆ Two types of EQ each with proprietary SoftSat limiter technology on each band:
Advanced EQ— 5-band Parametric with a 20Hz-20kHz frequency range, ± 18 dB boost/cut range, variable bandwidths.
Easy EQ—emulates vintage analog EQs with -12 dB/oct Hi and Lo cut filters, ± 18 dB Hi and Lo shelving fixed-frequency bands and a ± 18 dB Mid band with 5 frequencies

- ◆ Two Compressor algorithms – The Soft Compressor provides smooth and transparent dynamic control while the Vintage Compressor emulates the warm musical sound of classic analog compressors
- ◆ The Tools block provides a choice of specialized algorithms including a De-esser, Dynamic EQ (a De-esser with additional frequency range and control), Digital Radiance Generator (emulates tube saturation) and R.I.A.A. equalization which lets you connect a turntable to the mic-inputs.

TC ELECTRONIC

FINALIZER EXPRESS

Studio Mastering Processor



The Finalizer Express is an affordable studio mastering processor that provides a fast and efficient way of optimizing the overall perceived level of your mixes with the tools that will deliver the finishing touches of clarity, warmth and punch that your music deserves. The Finalizer Express is based around a Multiband Dynamics algorithm, inherited from the TC Finalizer 96K, and an LED matrix that enables you to choose between 25 different settings organized by Compression Rate and Compression Style ranging from smooth and subtle to aggressive and hard compression. Three Spectral Balance controls let you change the level relationship between low, mid and high, making it possible to independently control the level of the three compression bands. Post-processor fades can be performed within the digital domain using the fade knob or by using the optional TC Master Fader, and even controlled via MIDI. All I/O and internal processing is done at true 24-bit – 16 and 20 bit dither is also provided for delivering your material to a 16, 20 or even 24 bit digital media.

FEATURES

General

- ◆ Single rack space 24-bit mastering processor equalizes tracks with frequency selective compression – adds energy and clarity into mixes without creating digital “overs”
- ◆ Selectable 44.1kHz and 48kHz sample rates
- ◆ The multi-band compressor works over three frequency bands with fixed crossover points at 315Hz and 3.15kHz using 6dB slope linear phase digital filters.
- ◆ Auto Make-up Gain function compensates for the loss of gain through the compressor
- ◆ Balanced XLR analog inputs/outputs with 24-bit A-D/D-A converters and digital I/O including AES/EBU (XLR), coaxial S/PDIF and Optical Toslink

Spectral Balance

- ◆ Three-band EQ section with separate Low, Mid and High level boost/cut controls let you adjust the spectral balance of the signal
- ◆ Three Emphasis keys for adding compression and gain to the respective EQ bands

Fade In/Out

- ◆ Fades can be controlled using the front panel Fader knob, a remote Master Fader, or automated using a MIDI sequencer
- ◆ Fader values can also be transmitted via MIDI and recorded into a sequencer

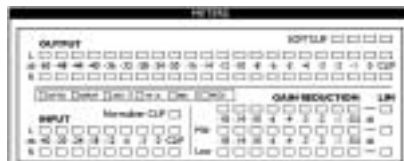

Normalize

- ◆ Switchable Softclip algorithm emulates the input stage of analog preamps providing the desirable effect of the analog soft saturation that adds warmth to your signal
- ◆ The Gain control sets the amount of gain for the normalizer and determines how hard the compressor section will be driven.

Metering

High resolution LED metering section gives you a clear readout of I/O levels, soft clipping, normalizer clipping and gain reduction for each of the three compression bands. LEDs also indicate digital input source, sample rate as well as MIDI activity.

Output Section

- ◆ Disengages all functions except Dithering letting you compare the original signal with the enhancements added by the Finalizer
- ◆ Control analog output gain (-26 to +6dB)
- ◆ Sync button lets you set the digital clock
- ◆ Toggle the digital Status bits used on all digital outputs

Finalize Matrix –

The Heart Of The Finalizer Express

The 5x5 LED Finalize Matrix delivers 25 compressor presets that are easily selected using four cursor keys – each preset contains independent Ratio, Threshold, Attack and Release settings for each of the three compression bands.

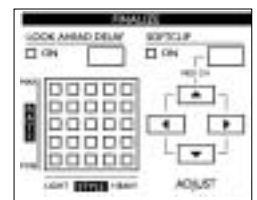

- ◆ The vertical axis of the matrix represents Compression Rate, the horizontal axis shows Compression Style
- ◆ Switchable 3ms Look Ahead Delay switch allows unwanted peaks and transients to be tracked and controlled at the exact moment they occur
- ◆ Softclipper smoothly eliminates any overshoot that might occur after the three bands are joined together – starts at -3dBFS and gradually increases with the level
- ◆ A multiband brick wall Limiter with a fixed ratio of ∞:1 prevents unintentional compressor overshoots from causing overloads

TC ELECTRONIC

FINALIZER 96K

Studio Mastering Processor



The Finalizer 96K takes the all-in-one stereo mastering processor concept to its highest level with true 24-bit / 96kHz processing and absolute control over every parameter over its advanced feature set including independent multi-band expansion, compression and limiting with definable crossover points, two insert effects blocks that allows you to choose from a wide range of appropriate shaping and enhancing tools. The Wizard function immediately calculates an optimal setting for your by asking you four simple questions concerning the source material and the type of processing you require. A group of analysis tools provide a visual reference and comparison between source material and the processed signal. The Finalizer 96K truly delivers unprecedented levels of clarity, warmth and punch to your mix putting the world of professional mastering within reach of every studio.

FEATURES

- ◆ Balanced XLR analog inputs and outputs and true 24 bit resolution A-to-D and D-to-A converters
- ◆ 100MHz processor makes it possible to process the entire signal using a 96kHz sample rate and achieve a maximum frequency response of 48kHz
- ◆ Sample Rate Converter translates AES/EBU, S/PDIF and Tos Input to the Finalizer's internal or external rate.
- ◆ The ADAT lightpipe interface enables you to freely choose 2 ADAT channels and direct them to other channels on the ADAT enabling you to bounce tracks while processing the sound with the Finalizer

Analysis Tools

- ◆ A wide range of extremely useful analyzer functions are available providing visual feedback of source material and processed signals including: Phase Correlation Meter, Level Flow Meter, Peak Hold Meter, Digital I/O Status as well as a Calibration Tone Generator
- ◆ The Digital Status Tool recognized incoming status bits from an external device (DAT, CD) and lets you decide how the status bits such as SCMS settings are handled and for converting from S/PDIF to AES/EBU or vice versa

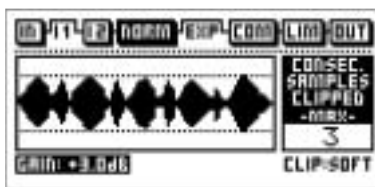

Normalizer

- ◆ The Normalizer block lets you optimize the signal's gain ensuring maximum utilization of headroom and benefit from the dynamics and effects blocks that follow
- ◆ A logical graphic display makes the adjustment a breeze
- ◆ You can choose between hard or soft limiting to avoid clipping

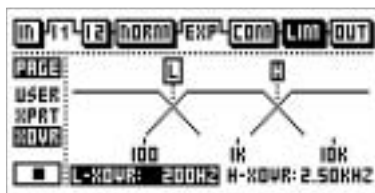

Crossover

- ◆ The Compressor, Limiter and Expander share three user-definable frequency bands allowing you to treat the low, mid and high frequency ranges independently without the 'pumping' or 'breathing' associated with conventional full bandwidth compressors

Expander/Compressor/Limiter

- ◆ These tools allow you to optimize the dynamics of your mix independently in three frequency bands
- ◆ The Expander, Compressor and Limiter each feature variable Threshold, Attack and Release controls for each of the three bands - Ratio is also variable for the Expander and Compressor but is fixed at $\infty:1$ for the Limiter. Each of the three Limiter bands can be individually bypassed
- ◆ Look Ahead Delay is individually adjustable for each of the dynamics processors - from off to 10ms - this gives each processor more time to react to the present signal
- ◆ A Range control allows you to set the maximum amount of gain reduction in the Expander as opposed to cutting off signals below the threshold
- ◆ The adjustable Crest parameter determines whether the Compressor should react to peaks or RMS (average) or anywhere in between

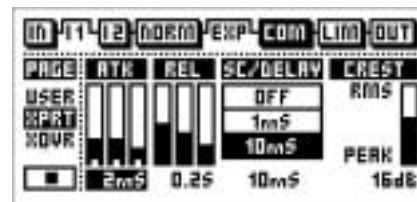

TC ELECTRONIC

FINALIZER 96K

Recall

- ◆ Recall page features a selected list of 30 presets in ROM suitable for any type of source material including: Commercials, Jazz, Techno, Classical, Rock, Live and more. An available RAM bank holds 128 user-definable presets

TPDF Dithering

- ◆ Signals can be dithered from 8-22 bits
- ◆ Three types of dither are available: Uncorrelated Dither (for low level stereo signals), Correlated Dither (the most unobtrusive for mono signals), Inverse Dither (for unfocused low level signals).

Up- and Down Sampling

- ◆ Input sample rates of 44.1, 48, 88.2 and 96kHz are accepted and can be up/down sampled to 44.1, 48, 88.2 and 96kHz
- ◆ When working with old or already finished material, you have the ability to Up Sample to 96kHz re-master the material
- ◆ Up/down sample option also makes you well prepared for the DVD-Audio or super-CD audio format

Insert Blocks



Two insert blocks located after the input section offer many useful effects including:

- ◆ Stereo Adjust allows you to increase the stereo width of a signal or collapse the image towards mono. You can also move the center balance from left to right
- ◆ Digital Radiance Generator (DRG) uses a drive control that adds analog-like second harmonic distortion to the signal – this process can provide a desirable warmth to digitally processed material. A curve control alters the character of the harmonics to better suit the specific source material
- ◆ Dynamic EQ is a compressor that works within a specific frequency range. It's similar to a de-esser but with more parameters (threshold, ratio, attack and release) and a broader frequency range with a choice of a bell curve or a shelving filter
- ◆ 5-Band Digital EQ – Lo and Hi shelving plus three full range bell-curved frequency bands, each with variable Q and ± 12 dB boost and cut – adjust the spectral content while preserving or enhancing the transparency and energy of your mix
- ◆ MS Encoding/Decoding includes balance and fine balance controls that allow you to change the relationships between the Mid and Side signals
- ◆ Spectral Stereo Image controls the stereo content in three bands independent of the Dynamics crossover. Use this to enhance the Stereo Image in a specific frequency range, e.g. widening the vocal area without removing the punch of the bassdrum
- ◆ External Inserts – The Insert block give you the ability to insert an external processor using the analog Inputs or digitally via AES/EBU, S/PDIF or Toslink

Wizard

With the Wizard function you are asked four basic questions about your source material and the type of processing you require and the Wizard will immediately calculate an optimized setting for your material. The more experienced user can use the optimized Wizard presets as a starting point and tweak the signal path extensively with more than 90 parameters to choose from.



Finalizer Model:	96K	Express
24 bit converters (A/D, D/A)	Yes	Yes
Multi-band Compression (3-Band)	Yes	Yes
TC Softlimiter	Yes	Yes
High Resolution Metering	Yes	Yes
Automation capability	Yes	Yes
Midi In/Out/Thru	Yes	Yes
External Control Input	Yes	Yes
Auto Sensing Power Supply	Yes	Yes
Automatic "make-up" Gain	Yes	Yes
RMS & Peak Detection Modes	Both	RMS
"Look Ahead" Delay for 3 bands	Global	Global
S/PDIF I/O's	Yes	Yes
ADAT I/O's	Yes	No
Tos Link I/O's	Yes	Yes
Normalizer	Yes	Yes
Simultaneous Digital Outputs	Yes	Yes
Dithering	Yes	Yes
Optional Master Fader	Yes	Yes
Adjustable Crossover Points	Yes	No
Storable Presets	Yes	No
Digital Radiance Generator	Yes	No
External Sidechain triggering	No	No
Inserts-External or Internal	Yes	No
5-Band EQ	Yes	No
De-Esser	Yes	No
Dynamic EQ	Yes	No
Stereo Width Adjust	Yes	No
MS-Encode/Decode	Yes	No
Expander/Gate	Yes	No
BNC Word Clock	Yes	No
Adjustable Limiting (3 Band)	Yes	No
Sample Rate Conversion	Yes	No
PCMCIA Card Slot for Preset Storage	Yes	No
Individual Crest Factor on 3 bands	Global	No
96 kHz/88.2 throughput	Yes	No
Full up and Down-Sampling	Yes	No
3-Year Parts/Labor Warranty	Yes	Yes

TC ELECTRONIC

M300

Dual Engine Processor



The M300 is a 24-bit effects processor with a dual engine structure that provides separate Multi-effect and Reverb effect engines that can be used independently or combined in a number of configurations. The no-nonsense user interface features dedicated, easy to use controls that provide immediate access to effects parameters without the need to scroll through layers of menus. High quality 24-bit A-D/D-A converters with balanced 1/4" TRS connectors, 24-bit coaxial digital I/O and 24-bit internal processing ensures pristine sound quality with a dynamic range of 100dB or more. Other features include tap tempo, 355 presets, MIDI I/O and more. Incorporating TC's legendary reverb and effects capabilities at an unprecedented price, the M300 is ideal for any PA, live or studio requiring high quality effects with immediate results.

FEATURES

General

- ◆ Dual engine structure – a Multieffect Engine with 15 different delay, modulation and dynamics effects and a Reverb Engine also with 15 effects
- ◆ Serial and dual mono routing allows the two independent effects engines to be used simultaneously
- ◆ High quality 24-bit A-D/D-A converters and 24-bit internal processing
- ◆ A total of 355 Presets are available — 256 factory presets comprised of combinations of 16 Multieffects and 16 Reverb effects and 99 user-defined presets

Input Section

- ◆ An input level control lets you set the optimum level for the analog or digital inputs
- ◆ A dedicated mix control sets the ratio between the dry and wet signals. In Dual Send/Return Routing, Mix controls the overall wet/dry mix of both effects sections; In Serial Routing, the Mix control works only on the selected effect engine
- ◆ The Bypass switch operates as a Mute function for each effect with Dual Send/Return routing and simply passes the dry signal unprocessed to the Output in Serial mode
- ◆ Effects Balance control allows you to set the ratio between the two effects engines

The Multi-effect Engine

- ◆ The EFFECT selector control lets you select between one of 15 effects and Off
 - ✦ Dynamic Delay
 - ✦ Studio Delay
 - ✦ Tape Delay
 - ✦ Delay
 - ✦ Ping Pong
 - ✦ SlapBack
 - ✦ Vintage Phaser
 - ✦ Phaser
 - ✦ De-Esser
 - ✦ Compressor
 - ✦ Chorus
 - ✦ Flanger 1
 - ✦ Flanger 2
 - ✦ Soft Tremolo
 - ✦ Hard Tremolo
 - ✦ Off
- ◆ Two multifunction knobs control different parameters depending on the selected effects algorithm — For delay effects, the knobs control a Timing multiplier and feedback, For modulation effects the knobs control amount and depth and for dynamics effects the knobs control drive amount and ratio (or frequency with the de-esser)
- ◆ -12dB, -6dB, -3dB Gain Reduction LEDs indicate the applied Gain reduction in the Compressor and De-Esser algorithms
- ◆ The tempo of Delay-based effects are set by tapping the Tap key to set a global tempo and then rotating the Timing knob (operates as a multiplier) to control the note value of the delay. The range of the timing knob is 0.5 to 2 (1 = a quarter note)
- ◆ Up to 5 seconds of delay is possible

The Reverb Engine

- ◆ 15 True Stereo Reverb algorithms deliver the best from TC in an extremely user friendly fashion:
 - ✦ Concert Hall
 - ✦ Living Room
 - ✦ Club
 - ✦ Plate I
 - ✦ Plate II
 - ✦ Spring
 - ✦ "Live" Reverb
 - ✦ Ambience
 - ✦ TC Classic Hall
 - ✦ Vocal Studio
 - ✦ Vocal Room
 - ✦ Vocal Hall
 - ✦ Drum Box
 - ✦ Drum Room
 - ✦ Large Cathedral
 - ✦ Off
- ◆ Dedicated PreDelay, Decay and Color parameter controls help you achieve your desired sound in seconds

Rear Panel

- ◆ 1/4" TRS analog inputs and outputs as well as auto-switching (44.1 & 48 kHz) digital coaxial S/PDIF I/O
- ◆ The 1/4" TRS Pedal Input gives you the ability to Bypass and Tap the global tempo via momentary switches
- ◆ MIDI In/Out recognizes MIDI Clock Tempo Sync and transmits/receives program change, CC data for realtime parameter control and SysEx data
- ◆ Internal switchable 100- 240v power supply



Multi-tap Rhythm Delay



Based on the history of TC's classic 2290 Delay, the D-Two offers a very musically oriented Rhythm Tap feature which can easily be applied to live sound and recording applications -as well as post production, broadcast, installed sound and a variety of other situations where a creative and intuitive delay can be used. Featuring up to 10 seconds of delay, the D-Two provides six direct-access add on features, including Spatial, Ping Pong, Reverse, Dynamic Delay, Chorus and Filter. 50 ROM presets and 128 user RAM preset locations are available. The D-Two's hardware compliment consists of full resolution 24-bit A/D and D/A converters. 1/4" analog I/O connectors are provided for fast and simple connectivity, additionally a S/PDIF digital I/O is included for an all-digital, 24-bit signal path supporting both 44.1K and 48K sample rates.

FEATURES

True 24-Bit

- ◆ State-of-the-art hardware with true 24 bit resolution A-to-D and D-to-A converters and true 24 bit RAM memory ensure the best possible audio quality
- ◆ Left and Right balanced analog 1/4" TRS inputs and outputs are provided as well as coaxial S/PDIF digital I/O – the digital output can be dithered from 16 to 24-bit
- ◆ Sample rates of 44.1 and 48kHz are supported

Three Delay Modes

- ◆ Traditional mode is a standard delay setup with feedback control
- ◆ In Straight mode, repeats are caused by a number of taps that are not fed back into the delay line providing you with ultimate control over the exact number of repeats
- ◆ Rhythm mode allows you to tap a specific rhythm using the Rhythm/Tap key or quantized according to a specific tempo and subdivision – after the last tap, the signal can be fed back into the delay line, generating a complete rhythm sequence
- ◆ The delays and rhythm patterns can be up to 10 seconds each
- ◆ There are 50 factory presets and 100 user-definable presets

Six Unique Add-On Effects

- ◆ Access to all parameters of the six add-on effects is available on the front panel – double click the key of the effect you wish to work with, and to instantly access the effects parameters
- ◆ TC's world acclaimed Chorus is provided using pitch-modulated delay
- ◆ Hi and Low cut filters with a frequency range of 19.95Hz to 20kHz can be applied to the delayed signal or to the incoming source signal allowing you to get a warmer and more natural sound or create delays that are less obtrusive on a mixes
- ◆ Spatial effect allows you to add more width to the sound of your material by offsetting the left channel up to ± 200 ms or by reversing the phase on any channel or both
- ◆ Reverse Delay effect processes the signal, and adds a backward delay
- ◆ Dynamic Delay allows the delay output level to be dynamically controlled by the input level – this leaves the source material undisturbed while played and delicately accompanied by the Delay between phrases
- ◆ The Ping Pong effect syncs panning to the delay time – three styles are available: L-R, L-C-R and right and Dynamic which will fit the number of Delay repeats with the number of panning positions



User Interface

- ◆ The intuitive user interface is aided by the detailed Multi Spectral LCD Display which gives you a complete overview of what is going on in the processor including Preset numbers, Input level and Dynamic (gain reduction) meters, Delay time, Tempo and Sub-Division and more.

MIDI

- ◆ MIDI clock is supported for tempo sync – incoming MIDI clock can be subdivided
- ◆ MIDI continuous controller capabilities allow you to control parameters externally in realtime or via a sequencer – all effects parameters can be changed via an external MIDI device through Sys-Ex

Conveniences

- ◆ Autoswitching internal power supply will power-up anywhere in the world
- ◆ The 1/4" pedal input can recognize two pedals simultaneously: The Ring pedal is fixed to Tap tempo while the Tip pedal can be set to Bypass, Tap tempo or Rhythm tap

TC ELECTRONIC

M•ONE XL

Dual Effects Signal Processor



The M•One XL is a 24-bit multi-effects processor with a dual engine design that provides you with high quality TC Reverbs along with a wide variety of other dynamics, pitch, modulation and delay algorithms. Flexible routing capabilities allows you to access the effects engines in a number of combined and independent configurations. The LCD display gives you a complete overview of input levels, selected input, clock source, routings and current algorithms. The dedicated Tap key and MIDI clock compatibility ensure that tempo-based effects including delay and modulation effects such as tremolo, will groove with the music. Positive-locking balanced XLR inputs and outputs with 24-bit A-D and D-A converters as well as coaxial S/PDIF digital I/O provide just the right connectivity for any live sound or recording studio application.

FEATURES

Dual Engine Effects

- ◆ 200 Factory presets are provided covering almost any imaginable application – 100 presets can also be stored on the User bank
- ◆ Dual Engine structure allows you to run two high quality effects, derived from 25 algorithms – run two of the best sounding reverbs or other quality effects simultaneously without compromising sound
- ◆ A wide range of high quality reverbs algorithms from classic Halls and Rooms to grainy snare reverbs such as Live and Plate each create sound reflections in various environments allowing you to easily add different levels of depth and color to your source material
- ◆ Other high quality effects algorithms include Compressor and Limiter, Delays, Chorus, Parametric Equalizers, Flanger, Gate, Expander, De-esser, Tremolo and Phaser

Inputs and Outputs

- ◆ 24 bit A-to-D and D-to-A converters and 24-bit internal processing at internal sampling rates of 44.1 and 48kHz or DI which locks to the incoming digital clock
- ◆ Balanced left and right XLR inputs/outputs
- ◆ Coaxial S/PDIF Digital I/O is also provided the output can be dithered to 16-, 20- or 24-bit (off)

Tap Tempo

- ◆ TAP key lets you Tap in the global tempo for time-based effects like delay and chorus. Tempo is displayed in BPM or milliseconds
- ◆ The tap key also lets you enter the Tap menu where you can set up the subdivision of the tapped tempo

User Interface

- ◆ Dedicated controls are provided for controlling input level, wet/dry mix and effect balanced between both effect engines
- ◆ Easy Parameter Level helps control important parameters and create cool effects
- ◆ Each algorithm has its own Edit button – up/down cursor keys and a large control wheel as well as dedicated enter/exit buttons allows you to intuitively navigate through each of the effects comprehensive range of sound shaping possibilities
- ◆ For maximum flexibility, separate bypass keys, each with its own assignable Bypass Mode, are provided for each effect engine –
0% Mix – passes the input directly to the output
FX Input – shuts off the Engine Input in order to let the effect "ring out", while allowing the dry signal to pass through
FX Output – shuts off the engine output killing the FX instantaneously while allowing the dry signal to pass through

Routing Flexibility

- ◆ A dedicated Routing key gives you the flexibility of choosing from 6 different routing configurations for the two effects engines
- ◆ The Routing Lock function allows you to stick with a single routing configuration when switching presets
- ◆ The Dual Send/Return setups the system up as two independent (mono in, stereo out) effects processors – The left input is sent to engine 1 and the right input is sent to engine 2. The four internal FX Outputs are then summed to the stereo outputs
- ◆ Parallel routing sums the left/right inputs, and both engines are fed with the exact same signal but not into each other – ideal for adding two effects to the same source
- ◆ Serial routing sends the input signal through engine 1 then engine 2 – ideal for combining two effects
- ◆ The Parallel/Serial option uses separate inputs on the two engines while an internal send control lets you decide how much of Engine 1 is fed into Engine 2
- ◆ Stereo Linked Routing allows true stereo processing with synchronized parameter settings for both engines (engine 1 is the master) – The left I/O feeds engine 1 while the right I/O feeds engine 2
- ◆ Dual Mono routing offers two totally independent engines with mono in/mono out of each Engine

TC ELECTRONIC

M•ONE XL

Multi-Spectral LCD Display



- ◆ Peak meters shows the Input level of the left and right channels within a range of 0 to -40 dB – Overload LEDs indicate whether the Input level is too hot or if there is an internal DSP overflow
- ◆ The Analog/Digital LED indicates the currently selected input source
- ◆ The Sample Rate indicator shows the clock source and the incoming master clock
- ◆ The Routing indicator shows what Routing mode(s) are currently in use
- ◆ The ALGO Indicator shows the current algorithms in each of the effects engines
- ◆ Two Dynamic meters show the amount of gain reduction when an Engine is using any Dynamic algorithms
- ◆ The preset number and the preset type (Factory or User) are also displayed
- ◆ The “Edited” icon is lit as soon as the current recalled preset has been modified
- ◆ The MIDI IN icon shows any incoming MIDI activity



MIDI Section

- ◆ All effect parameters can be accessed via standard MIDI controllers allowing real-time control and automation with virtually any sequencer or other MIDI devices
- ◆ You can also use MIDI to dump & save the entire user bank to a MIDI sequencer
- ◆ The TAP Tempo function of the can be locked to the incoming MIDI clock

Additional Features

- ◆ A 1/4” pedal input accepts a momentary switch for controlling bypass or tap
- ◆ Internal auto-switching power supply – 100 to 240 VAC, 50 to 60 Hz
- ◆ 1 year parts and labor warranty

Effects Algorithms

- | | | | |
|--------------|----------------------------|-------------------------------|---------------------------|
| • Hall | • Ambience | • Flange: Classic & 4-voice | • Gate/Expander |
| • Room | • Delay One Tap | • Pitch: Detune & Pitch Shift | • De-esser |
| • Small Room | • Delay Two Tap | • Parametric EQ | • Tremolo |
| • Plates 1&2 | • PingPong Delay | • Compressor/Limiter | • Phaser Vintage & Smooth |
| • Spring | • Chorus Classic & 4-voice | | |
| • Live | | | |

Also Available: The Original M•ONE

The original M•ONE is still available and may be a viable option for users with unbalanced equipment and for guitarists. It has the same features as the M•ONE XL less the XLR connectors (the M•ONE has 1/4” I/O) as well as the specific algorithms that have been optimized for live applications. Other features of the M•ONE XL that are not available with the M•ONE include Ping-Pong Delay, additional reverb size tunability, MIDI mapping and Tremolo Pitch.

TC 2290 Dynamic Digital Delay

Acclaimed as the industry standard Digital Delay, the TC 2290 can be found in recording studios, PA rigs and guitarists’ FX racks the world over. The TC 2290 combines unique operational features and superior sound quality, allowing you a greater degree of musical creativity in the use of effects.



- ◆ 1/4” and XLR inputs and outputs
- ◆ Programmable Chorus, Ducking, Gating & Panning
- ◆ 4 seconds memory (8 seconds in Double Sample / Double Delay time Mode)
- ◆ 20Hz - 20kHz bandwidth and a 100dB dynamic range
- ◆ The most functions are accessible from the front panel including a numeric keypad for data entry, “Learn” button for easy entry of delay time and tap tempo control.

- ◆ Feedback control with phase invert as well as Low Pass (8, 4, 2 kHz) and Hi Pass (100, 200, 400 Hz) filters.

Dynamic Control

- ◆ The input signal dynamically controls 3 independent LFOs providing unique chorus, flanger, ducking, gating and pan effects
- ◆ The Dynamic Function enables you to suppress the effects when you are playing and let the effects reappear when you stop playing or the opposite.

Modulation

- ◆ Individual control is provided for Delay, Pan and Dynamics – waveforms include Sine, Random, Envelope, & Auto Trig.

MIDI

- ◆ MIDI enables the TC 2290 to operate as a “main brain” of an FX rack. External FX units or foot pedals can be incorporated into the chain of five programmable effects loops which can be stored within the patch memories.

ORDER & INFO. (212) 444-5088 • FAX: (212) 239-7770 (800) 947-7008
1-800-875-6951 • www.bhphotovideo.com



TC ELECTRONIC

M3000

24-Bit Studio Reverb Processor



The M3000 is a single rack space, dual engine effects processor that features an advanced set of reverb algorithms along with a full compliment of other TC-quality signal processing algorithms including delays, pitch, modulation, dynamics, EQ and more. At the heart of the M3000 is the VSS3 (Virtual Space Simulator) reverb algorithms—representing years of research in reverberation technologies in pursuit of optimal realism, smoothness and clarity of both real and imagined spaces. A fast and intuitive user interface provides easy recall and editing of 100s of factory presets which can be stored in RAM or PCMCIA card. The back panel features gold plated connectors and includes AES/EBU, S/PDIF, Toslink, ADAT-optical, MIDI and balanced XLR analog I/Os as well as a pedal input. Multiple simultaneous digital outputs can be used with all of the digital connectors. Additional features include LCD display, LED metering, and output dithering.

FEATURES

Dual Engine

- ◆ Dual Engine processing fuses TC's proprietary DARC chip technology with a powerful Motorola 80 Mips DSP chip to deliver the intensive processing power necessary to calculate the huge number of sonic details made available within the VSS 3 algorithms
- ◆ The Dual Engine structure allows any combination of full-blown algorithms to be run on each engine simultaneously – the two engines can be linked providing true stereo processing
- ◆ Choose from 6 different routing setups including serial, parallel and dual input, dual mono, stereo linked as well as Preset Glide which allows you to crossfade between two effects

VSS 3 Virtual Space Simulator

- ◆ Provides the highest degree of smoothness and clarity to the reverb tail with the ability to keep the signal 100% free of sound deteriorating modulation – modulation is still available as an option
- ◆ A large number of directional taps (between 40 and 100) are employed, creating accurate early reflections that aid in simulating the sonics of actual rooms
- ◆ Gentle signal processing ensures that the signal is always 100% correct pitch, even with extensive effects processing

More Algorithms

- ◆ Apart from the VSS3 and VSS3 Gate Reverb algorithms, you can choose between C.O.R.E. Reverb (based on TC's M5000 processor), REV-3 Reverb, Delay, Pitch, EQ, Chorus, Flanger, Tremolo, Phaser, Expander/Gate, Compressor and De-Esser

Presets

- ◆ 600 high-grade factory presets – 500 single engine presets plus 100 presets that combine engines 1 and 2, cover most any application imaginable
- ◆ An internal RAM bank allows you to store store 250 single and 50 combined presets
- ◆ The PCMCIA card slot on the front panel can be used to store an additional 250 single and 50 combined presets

Tap Tempo

- ◆ Tap Tempo key not only lets you match the Delay Time to the rhythm of a track, you can also use tap tempo to set the parameter for Reverb Decay, Chorus Speed, Flanger Speed, Phaser Speed or Tremolo Speed

Dynamic Morphing

- ◆ Dynamic Morphing allows you to morph from the preset on one engine to the preset on the other – controls are provided for the threshold level and the transition speed

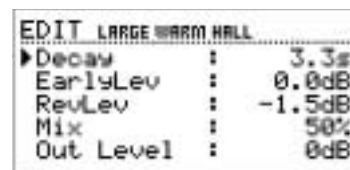

Editing

- ◆ Each of the two Engines has it's own Edit key giving you the option of editing presets and changing any parameter to create the exact ambience or effect you want
- ◆ Every parameter is on one scrolling page with the most used parameters at the top – No "nested" menus with their hard to find parameters
- ◆ VSS3 and VSS3 Gate reverbs can be edited in either Easy Mode or Expert Mode
 - In Easy Mode the Hi Color and Lo Color tools let you edit the complex spectral balance of the reverb in a second
 - In Expert mode you have access to a wide number of well-arranged parameters

Wizard

- ◆ Wizard function is a fast and intuitive way to get the sound needed for your work. Simply select the application, source and size you are looking for and the M3000 suggests a number of presets matching your request.

TC ELECTRONIC

FIREWORX

Studio Effects Processor



The FireworX is a radical sounding, extremely flexible multi-effects processor designed to challenge your imagination. A wide variety of internal effects, based on over 35 different algorithms can be inserted on an easy to use 8x8 routing grid, and controlled in realtime via a powerful yet intuitive modulation matrix. An advanced digital signal processor along with TC's proprietary DARC 3 chip technology allows the FireworX to run multiple effects simultaneously. A dynamic processing power allocation structure ensures that you always get the advantage of the full power of the FireworX allowing you to keep adding algorithms to the signal chain until all the processing power is used. Hundreds of factory and user presets plus a PCMCIA card slot for additional storage. Balanced analog inputs and outputs using 24-bit converters as well as a full compliment of digital I/O and word clock in is provided as is MIDI In/Out/Thru and a 1/4" external control input.

FEATURES

Effects

- ◆ 200 Factory Presets and room for up to 200 User Presets (depending on the size of the presets) – up to 999 additional presets can be stored on an optional PCM CIA card
- ◆ A word search filter allows you to scroll through presets that contain a specific algorithm such as Reverb

Effects Routing

- ◆ 8x8 position routing grid lets you place any of the over 35 algorithms anywhere on the grid where they will be automatically "wired" together – Left/Right can be set up separately for Input/Output in each block

Modifier Matrix

- ◆ A total of nine external and eleven internal Modifiers can be tied to numerous parameters – up to twenty connections can be made simultaneously
- ◆ External Modifiers can be controlled via MIDI controllers, Velocity, Pitchbend, Aftertouch, Note-onkey etc
- ◆ Internal Modifiers include: 2 envelope followers, 2 ADSR generators, 2 LFO's, a Pitch detector as well as a Free Form modifier that uses a sequencer that lets you design your own modulation waveform to create a rhythmic sequence

User Interface

- ◆ The twelve effect block keys on the front panel are used for bypassing or muting the active effect blocks
- ◆ Navigation is made simple via Left/Right arrow keys, parameter and value wheels as well as Enter and Exit buttons
- ◆ The Alpha Modulation wheel provides realtime control of a number of parameters in the current preset simultaneously
- ◆ All pertinent info is clearly layed out on the 56 x 128 dot backlit LCD display
- ◆ Left/Right LED input level and gain reduction meters are also provided

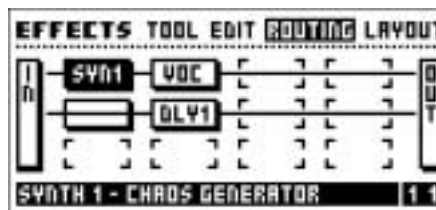

Tempo Control

- ◆ All tempo based parameters can be connected to the global tempo
- ◆ The global tempo can be tapped, dialed in, or MIDI clock based
- ◆ Each parameter can be set from 16 bars through 1/1 to 1/32 straight, dotted or triplet subdivisions of the global tempo

Inputs and Outputs

- ◆ Balanced XLR analog inputs and outputs with 24-bit A-to-D and D-to-A converters as well as AES/EBU, S/PDIF, Toslink and ADAT digital I/O
- ◆ Wordclock input (RCA)
- ◆ External control input
- ◆ Analog or digital I/Os can be used as an insert loop making it possible to connect an external device

Algorithms

Dynamic –	Expander/Gate, Soft Compressor Hard Comp/Limiter
Vocode –	Vocoder, Ring Mod. Internal, Ring Mod. External
Formant –	Formant
Pitch –	Single Voice, Dual Voice
Filters –	Resonance, Bandpass, Phaser, Resonator, Resochord
Distort –	Drive, Cruncher
Synth –	Curve Generator, Chaos generator, Noise Generator
Reverb –	Simple, Advanced
Chorus/Flanger –	Classic Chorus, Advanced Chorus, Classic Flanger, Advanced Flanger
EQ –	Fixed EQ, Modifiable EQ
Delay –	Stereo, Dual, Dual three-tap One-tap, Six-tap, Reverse
Panner –	Simple Tremolo, Advanced Tremolo Simple Panner, Surround Panner, Stereo Enhancer

TC ELECTRONIC

INTONATOR

Vocal Intonation Processor



The Intonator is a high resolution pitch correction processor aimed at reducing the often tedious task of doing vocal re-takes. Intuitive user interface gives you a choice between manual and automatic pitch correction with complete control over scale, correction amount and additional parameters that allow you to preserve the artist's unique vibrato and initial intonation while providing correction of targeted notes. Besides offering comprehensive pitch correction, the Intonator offers a variety of valuable vocal-specific processing tools including a De-esser and a special Adaptive LoCut filter (ALC) that automatically adjusts in relation to the current pitch. There is also TC's world-renowned DARC 3-chip technology, 96kHz processing and premium 24-bit A-D and D-A converters for an ultra-transparent signal path worthy of your most precious vocal tracks. To ensure compatibility with any audio system, the Intonator is equipped with XLR-balanced inputs and outputs as well as a full range of digital I/O and a word clock input.

FEATURES

Transparency

- ◆ Proprietary DARC 3 chip technology incorporates 96kHz internal processing and true 24 bit resolution that provides an ultra-transparent signal path
- ◆ Balanced XLR inputs and outputs – analog input and output gain controls allow you to take full use of the dynamic range available by the premium 24-bit converters
- ◆ Fully integrated AES/EBU, S/PDIF, Tos-link and ADAT digital I/Os with TPDF output dithering (8, 12, 16, 20, 22 or 24 bit)
- ◆ 96kHz, 88.2kHz, 48kHz and 44.1kHz compatible on both digital and analog I/O's

Pitch Correction

- ◆ Use the "Do-not-process-anything-but-this-note" function to correct only a single note or type in your personal scale
- ◆ The Window knob determines how close to the target note, ± 200 cent, the source should be in order to be corrected (100 cent is 1 semitone)
- ◆ The Attack knob controls how fast the pitch is corrected to the "correct" note
- ◆ The Amount knob sets the amount of correction added to the signal
- ◆ The Note Hold key is used to hold the current corrected pitch

Display and Keyboard

- ◆ The Display shows you the current Root note and Scale. While processing you can see both the incoming signal and the amount of correction added to the source, creating a visual confirmation of the process taking place
- ◆ The one octave keyboard on the front panel gives you instant access to changing the Root note of the current scale or the notes allowed to be corrected – it also indicates the incoming note, making it possible to recognize the note about to be processed

Audio-To-MIDI

- ◆ You can monitor and edit vocals externally by tracking the incoming pitch history to a MIDI sequencer, making the necessary corrections and play back the pitch corrections via MIDI back to the Intonator
- ◆ You can also use a MIDI keyboard for real-time manual pitch correction simply by hitting the notes to be processed

Manual Pitch

- ◆ The Manual Pitch control allows you to add pitch correction by hand
- ◆ The wheel can also be remote controlled by keyboard modulation wheel or even automated when locked to a sequencer

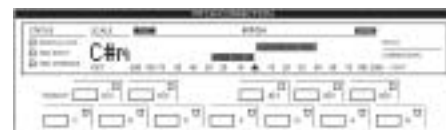

De-Esser

- ◆ The De-esser uses a relative threshold technique allowing the De-esser to adapt to the incoming signal and maintain the same threshold to the average level regardless of the input signal

LoCut Filter

- ◆ The LoCut filter can be used either in a conventional (fixed) mode or an adaptive mode where the LoCut is controlled via pitch – ensuring a perfect LoCut that never removes too much low end

Two Signal Setups

- ◆ In Normal mode, the ADIOS (Analog Dual I/O's) configuration lets you to make simultaneous recordings of processed and unprocessed vocals, making comparisons a breeze
- ◆ In Dual mode you have the option of pitch-correcting the signal in one channel while using the dynamics, De-esser and LoCut, on the signal in the other channel

TC ELECTRONIC

REVERB 4000

The Stereo Incarnation of System 6000



The Reverb 4000 delivers the massive System 6000 Reverb Palette to you in a single rack space true stereo processor. Reverb 4000 is powerful enough to be your main reverb delivering the depth, localization, spaciousness and character demanded by world class recording facilities. It utilizes the latest hardware technology and software based upon 30 man-years of development. Its broad palette spans from new state-of-the-art Reverbs to world-renowned classics, and includes the best stereo reverbs and presets from System 6000 and M5000. A full complement of I/O protocols is supported including balanced XLR analog I/O, AES/EBU, S/PDIF and ADAT digital I/O. This ensures that the Reverb 4000 will integrate seamlessly into any production environment — from computer based DAWs to large-format mixing consoles. The extremely easy to use instant access interface provides instant access to key parameters, plus you are given the option of connecting the Reverb 4000 to your computer via USB where allowing you to access using the intuitive ICON software editor for Mac/PC.

FEATURES

- ◆ 44.1 to 96kHz sample rates and processing
- ◆ 24 bit A-to-D and D-to-A converters as well as 44.1 to 96kHz Sample Rates
- ◆ One engine, massive SRAM, no compromise design.
- ◆ VSS-4 allows you to create realistic stereo spaces from two discrete sources.
- ◆ Digital and analog wide dynamic range topology
- ◆ Over 150 preset and user programs

The Ultimate Reverb Palette

- ◆ True Stereo Reverbs taken from the renowned System 6000
- ◆ New pristine Stereo Reverb
- ◆ Favorite presets and algorithms from the M5000
- ◆ Realistic Environments from a closet to a canyon
- ◆ VSS-4, Source based Reverb providing Rooms with Character
- ◆ Classic Reverbs providing Polished Sustain
- ◆ Vintage Reverb emulations including EMT 250 plate.

Instant Access User Interface

- ◆ The front panel provides instant access to key parameters - locating presets from System 6000, M5000 and vintage devices is a breeze with the dedicated Search function. Switch between Character, Glossy and Vintage Reverb effects with just a single touch of a button.
- ◆ 56 x 128 dot backlit graphic LCD display.
- ◆ PCMCIA card slot supports up to 2 MB SRAM for storing additional programs.

ICON Software Editor

- ◆ The included ICON software editor for Mac/PC provides easy access to the Reverb 4000 functions with a complete overview for detailed editing purposes.
- ◆ The USB connector on the rear of the Reverb 4000 connects directly to the ISB port of your Mac or PC for accessing the ICON software.
- ◆ Ideal for live sound applications as well as integrating with computer-based DAWs.

Inputs and Outputs

- ◆ Balanced XLR analog inputs and outputs
- ◆ AES/EBU, S/PDIF, TOS-Link and ADAT digital I/Os.
- ◆ The MIDI In, Out and Thru connectors are provided for controlling any parameter from a sequencer or from a remote midi controller.
- ◆ Word Clock input (RCA) ensures accurate sample rate synchronization.



TC HELICON

QUINTET

Affordable, Pro-Quality Vocal Harmony and Reverb for Stage and Studio



The Quintet is an affordable, professional quality vocal harmony and reverb processor for both live and recorded vocal applications. It combines TC Helicon's renowned harmony algorithms and TC Electronic's famous Reverb technology along with a high quality microphone preamp. The Quintet is also fast and easy to use — editing and control of all harmony and effect parameters either from the front panel or via MIDI. Using the Quintet live is like bringing four professional backup singers to your gig. The studio quality mic preamp and 24 bit A-to-D conversion alone justifies the Quintet's place in your rack. Add to that the ability to create high quality, solo-able harmony vocals and you see what makes the Quintet an indispensable tool for your studio.

FEATURES

- ◆ HybridShift harmony generation delivers a smooth, natural sound.
- ◆ Four harmony voices plus lead voice double-tracking with control over timing and Pitch Humanization of harmony voices.
- ◆ Five distinct harmony Modes:
 - Scale (Scalic) Mode** harmonies use key and scale information to create musically correct, diatonic harmonies.
 - Chordal Mode** harmonies take your chord information, that you input in realtime via MIDI, to create intelligent, diatonic harmonies based on your voice.
 - Shift Mode** takes the pitch of the lead voice and creates harmonies a set number of semitones away, based on that pitch.
 - Thicken Mode** presets do not produce harmony voices, instead they produce voices in unison with the input voice. The unison voices have pitch and time humanization applied to them to make them sound as if sung by another person.
 - In **MIDI Notes Mode** you provide specific MIDI note information to determine the pitch of the harmony voices.
- ◆ Selectable equal temperament or just tuning for harmonies.



User Interface

- ◆ Fast and easy to use with straight forward and simple editing with control of all harmony and effect parameters either from the front panel or via MIDI.
- ◆ 50 Presets are provided as a starting point. Each preset can be modified to suit your needs and overwritten.
- ◆ A/B program switching allows bulletproof program changes during live performance.

TC Electronic Reverb

- ◆ The reverb section adds depth and space for blending harmonies. A variety of high quality acoustic reverb simulations are provided including Living Room, Chamber, Club, Classic Hall, Concert Hall, Large Cathedral, Vocal Studio, Vocal Room, Vocal Hall, Ambience, Live Reverb, Plate1, Plate2, and Spring.

Inputs and Outputs

- ◆ High-quality balanced XLR mic preamp with variable gain and a 20dB pad.
- ◆ Mono 1/4" TRS balanced/unbalanced line level input.
- ◆ 24-bit processing with 44.1/48 kHz
- ◆ 24-bit Coaxial S/PDIF digital output
- ◆ MIDI In, Out and Thru connectors allow you to use MIDI CC to 'echo' the front-panel controls.
- ◆ 1/4" footswitch input compatible with the TC Helicon Switch-3 footswitch controller.

Switch-3 Footswitch

- ◆ Three-button footswitch is the standard footswitch for controlling the Quintet, VoicePrism, VoicePrismPlus, VoiceOneand VoiceWorks.
- ◆ Provides remote control of such features as, Bypass, Harmony Mute, Preset Up, Preset Down and more...
- ◆ Durable all-metal construction, making it durable and portable. It also includes the connector cable.

TC HELICON

VOICEPRISM PLUS

Vocal Formant Pitch Processor

The VoicePrism Plus is an entire vocal channel that provides the ability to go directly from a phantom powered mic into a high quality mic preamp where it can access a variety of fully editable onboard vocal processors including: compression and gating; dual fully parametric EQ; four harmony channels with individually adjustable gender and humanizing parameters), a 5th lead-doubling voice; and 2 independent post-effects blocks with a choice of chorus/flange, delay and reverb. The included VoiceCraft card provides a number of unique voice modeling algorithms that allow realtime resynthesis and reshaping of the human voice including the ability to add breath, growl, rasp, head and chest resonance, inflection or vibrato.

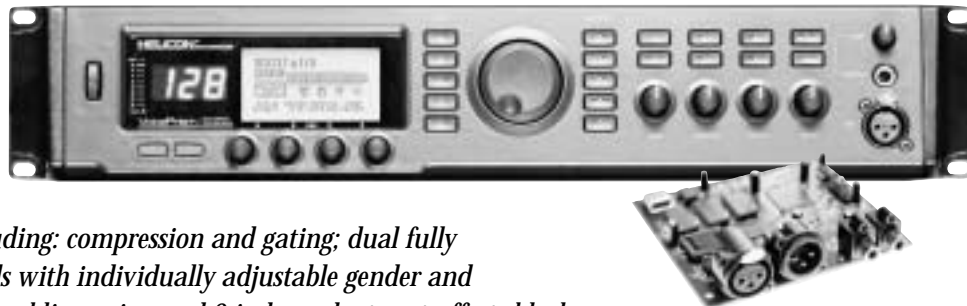

PROCESSORS

339

FEATURES

- ◆ Contains a complete complement of tools designed to expand what is possible to achieve with the most beautiful of all instruments, the human voice.
- ◆ The VoicePrism has a full range of lead and backing channel vocal processing under preset control.
- ◆ 24-bit A-to-D and D-to-A converters

Processing Stages

- ◆ The **Front End** features a high quality mic preamp with switchable phantom power that provides direct access to a variety of onboard dynamics, harmony and effects processors.
- ◆ The **Pre Effects** section provides compression and Gating and a dual fully parametric EQ that can be assigned to the lead channel, the harmony channel or both.
- ◆ The **Harmony Channel** provides up to four-voice harmony formant corrected pitch shifters to create very natural harmony voices from your vocals. Each voice also features independent humanizing parameters including: Gender, Vibrato, Timing, Randomizing and Scooping.
- ◆ The **Lead Channel** has a thickening algorithm to create double tracking effects.
- ◆ Using the two **Post Effects** blocks you can apply to your Lead and Harmony voices including Chorus, Flange, Delay and Reverb with Pre-delay to create interesting and unusual spatial effects.

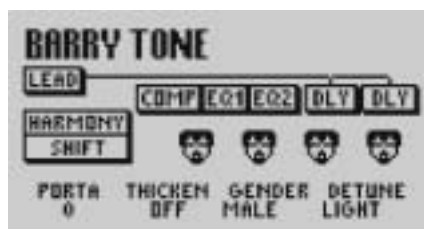

Intuitive Interface

- ◆ 128 fully editable effects and harmony preset libraries are easily accessible via an intelligent browser with context sensitive help menus, as well as the ability to audition sampled human voices for preset previewing.
- ◆ Dedicated edit buttons allow you to jump directly to multi-page edit menus – Vocals, Effects, Comp/EQ, Mix, Step.
- ◆ The 128 x 84 LCD Display shows preset information as well as menus where you can view your editable features.
- ◆ Four multifunction softknobs, underneath the LCD display, can be pushed and turned to quickly navigate through parameters and modify their settings.
- ◆ The Data Wheel provides additional navigation and editing control.
- ◆ A numeric preset number display and 10-segment LED level meters are provided for additional operating status.

Inputs and Outputs

- ◆ Balanced 1/4" TRS line inputs and outputs.
- ◆ A balanced 1/4" TRS balanced auxiliary input allows you to integrate additional audio material into the final effects blocks and mix them there with the vocals.
- ◆ Input sensitivity for the line and aux ins are switchable for +4dBu or -10dBV operation.
- ◆ Coaxial S/PDIF digital output at 44.1kHz
- ◆ 1/4" headphone output with level control on the front panel.
- ◆ Can be configured to use a 1 or 3 button footswitch. You can set the number of buttons and assign button functions in the FOOTSWITCH menu, accessed by pushing the UTILITY button.
- ◆ MIDI In, Out and Thru allows realtime parameter control via MIDI CC.

VoiceCraft Card

- ◆ The optional VoiceCraft card, included with the VoicePrism Plus, adds human voice modelling DSP algorithms that provide realtime resynthesis and reshaping of the human voice including the ability to add breath, growl, rasp, head and chest resonance, inflection or vibrato. The Card also adds AES/EBU and S/PDIF I/O.

TC HELICON

VOICEONE

Voice Pitch Shifting, Correcting And Modeling Tool

The VoiceOne is a powerful production tool that offers a unique range of voice-specific pitch shifting and



VoiceModeling algorithms designed to open up a whole new world of possibilities for enhancing, harmonizing, transposing, correcting and otherwise transforming vocal performances. Using VoiceOne's next generation VoiceModeling algorithms you can sculpt a vocal to have unique elasticity, breathiness, growl, rasp and resonant characteristics. Ideal applications for VoiceOne include: adding strength, resonance and overall character to weak vocal performances; adding breathiness and more head-tone to a darker voice; re-pitch or pitch-correct an existing vocal while maintaining the natural formants; re-phrase an existing vocal to change the timing and feel of a vocal line; create convincing harmony and doubling; create new and original vocal effects. Vocal modeling effects can be manipulated in realtime allowing you to enhance particular notes or phrases and create lush and vibrant background vocals from a single solo performance. 24-bit processing and A-to-D, D-to-A converters as well as XLR balanced analog and S/PDIF digital I/O ensure that the integrity of the source material will be maintained throughout the signal path.

FEATURES

- ◆ Combines superior voice shifting and correction (± 2 octaves) with award-winning, second generation VoiceModeling technology to provide an amazingly creative tool for processing vocals.
- ◆ The vocal-trained (voice-specific) **Pitch Recognition** algorithm employs a highly stable pitch detector that provides extremely accurate handling of vowels, hard consonants and sibilants thus ensuring that shifted vocals stay natural.
- ◆ **Intelligent harmonization algorithms** – harmonies can be controlled via MIDI, internal scale, or you can custom write your own scales.
- ◆ **Hybrid Pitch shifting algorithm** combines standard 'instrument' pitch shifting (suitable for small intervals) with formant-corrected pitch shifting which is more apt at preserving the voice characteristics over large intervals. Combining the two provides unlimited flexibility and control for achieving both natural and supernatural sounds.
- ◆ The enhanced pitch recognition is also a key component to VoiceOne's superior Pitch Correction providing fewer errors and artifacts and faster results when fixing intonation problems. Using the adjustable pitch correction/re-pitching window (0-600/infinite cents), and the hybrid shifter, you can correct and even re-pitch vocal lines keeping them natural sounding or extreme – even over wide intervals.



- ◆ Custom Main LCD display giving feedback on key data with a flexible and simple to use parameter editing interface
- ◆ 100 Factory/50 User presets
- ◆ Balanced XLR inputs and outputs with 24 bit A-to-D and D-to-A converters with 24 bit internal processing driven by a powerful 100 million instruction per second DSP engine.
- ◆ S/PDIF digital I/O is also included for a pure all digital, 24-bit signal path supporting both 44.1K and 48K rates.
- ◆ MIDI In/Out/Thru provides pitch to MIDI conversion as well as extensive MIDI control of effect parameters echoing most front panel functions
- ◆ The 1/4" footswitch connector supports momentary single or three-button external footswitches for remote control of select parameters

Next Generation VoiceModeling

- ◆ Next-generation advanced VoiceModeling allows you to enhance or even transform vocals using a variety of algorithms
- ◆ The **Flextime Inflection** algorithm seamlessly stretches and shrinks the pitch and time of a vocal line (up to 500ms) allowing it to breathe. Ideal for doubling and harmonies as well as providing you with control for radically altering phrases.
- ◆ The independently adjustable **Breath** and **Growl** algorithms provide a wide range of natural to extreme sounds.
- ◆ The **Real Vibrato** algorithm features controls and styles based on real singers from all styles of music
- ◆ The **Spectral** algorithm is a Voice Optimized Equalizer that allows you to intelligently dial up a high-boost curve for a vocal without boosting hard consonants and esses.
- ◆ The **Resonance** algorithm allows you to create, remove or enhance chest tones and head tones, as well as set the apparent length of the vocal tract.



For Any Inquiries Regarding Your Order, Call Our Customer Service:
(800) 221-5743 • (212) 239-7765 • FAX: (800) 947-2215 • (212) 239-7549

TC HELICON

VOICEWORKS

Harmony, Pitch Correction and Effects Processor

The VoiceWorks combines multi-voice harmonies, fat automatic double-tracking and transparent pitch correction, along with superb TC Electronic effects – all in a one rack space



unit. VoiceWorks utilize TC Helicon's state-of-the-art humanizing and HybridShift functions that give you complete control over the sound and allow you to create natural sounding harmonies that sound authentic even when soloed. VoiceWorks also employs TC Helicon's latest innovation the HarmonyHold function which lets you sustain back-up harmonies while you sing over them. The critically acclaimed TC Electronic Compression, EQ, Tap-Tempo Delay and Reverbs allow you to add that finishing touch to your processed vocals. Audio can be input to the VoiceWorks via the studio-quality mic pre-amp, balanced/unbalanced line input or the coaxial 24-bit S/PDIF digital input. The processed signal can be output via either the coaxial S/PDIF digital output or the balanced/unbalanced 1/4" line outputs. Full MIDI implementation allows you to control virtually every parameter of the VoiceWorks remotely including the ability to automate parameters from your favorite sequencing application. Designed for live and recording situations – anywhere superior vocal processing is required.

- ◆ HybridShift harmony generation for smooth, natural sound
- ◆ Four independent harmony voices accessible from four distinct harmony Modes: Scalic, Chordal, Shift and MIDI Notes.
- ◆ 2 Lead-voice Thickening Voices - one voice above and one voice below
- ◆ Humanization of harmony voices utilizing: FlexTime, Vibrato, Inflection, Pitch randomization and Portamento
- ◆ Selectable Equal-tempered and Just tuning for harmonies
- ◆ HarmonyHold lets you freeze harmonies while continuing to sing over them.
- ◆ Fully adjustable gender and voicing per voice

Pitch Correction

- ◆ The built-in scale-based Pitch Correction function listens to the pitch of the incoming voice, compares it to the selected correction scale, and then applies pitch correction in realtime. Besides scale type, you have control over the amount of pitch correction to be applied, attack (or speed) at which pitch correction is activated as well as a window parameter which controls how out of tune a note needs to be before pitch correction is applied.
- ◆ Suitable for studio and live performance.

Presets

- ◆ 100 presets are provided as a starting point. These presets can be easily customized and overwritten.
- ◆ Song Mode for live performance allows you to save internal "sequences" of up to 50 songs with 30 user presets per song.

Effects

- ◆ The flexible TC Electronic 3-band EQ provides frequency adjustable high and low shelving bands as well as a fully parametric band with Q frequency and Gain controls. EQ can be applied to the Lead, Harmony or both the Harmony and Lead channels.
- ◆ The TC Electronic Dynamics section allows you to apply compression and gating to the Harmony, Lead or both the Harmony and Lead. The compressor has a variable threshold with a range of 0 to -60 dB and a ratio variable from 1.1:1 to 64:1. The compressor also features an auto makeup gain circuit. The gate has a variable threshold with a range of -70dB to 0dB.
- ◆ The TC Electronic effects section provides a variety of Reverb and Tap-tempo Delay processing. Individual aux sends for each effect allow you to control the amount of each effect for the Harmony and Lead channels independently.

Mic Input

- ◆ High quality mic preamp with 48V phantom power, variable gain and a 20 dB pad.

Inputs and Outputs

- ◆ 24-bit A-to-D and D-to-A converters
- ◆ Balanced XLR mic input and a 1/4" TRS balanced/unbalanced line level input.
- ◆ Balanced left and right 1/4" TRS outputs
- ◆ Coaxial S/PDIF digital I/O
- ◆ MIDI In, Out and Thru provides access to MIDI CC control over all parameters
- ◆ The 1/4" Footswitch input is compatible with both single and 3-button footswitches (including TC Helicon's Switch-3) and provides remote control of Bypass, Harmony Mute, Preset Up/Down and more.



Additional Features

- ◆ Easy to read and comprehensive 16 character by 2 line backlit LCD display
- ◆ 5-segment LED level meter as well as independent input and output clip LEDs.

TL AUDIO

5001

PROCESSORS

4-Channel Tube Mic Preamp

In addition to offering four top quality tube mic preamps in a single 2U package, the 5001 also features a discrete mic preamp stage, 30dB pad, instrument DI inputs, improved metering and optional 24-bit digital output. The combination of sound and facilities is guaranteed to bring out the best in any microphone. Separate input and output



level controls allow the tube stages to be driven harder if necessary for increased warmth, while still allowing the overall output level to be regulated - absolutely essential if recording direct to tape. The output fader permits anything from complete attenuation through to +15dB of extra output gain - making it ideal for driving today's high level digital recorders.

- ◆ Continuously variable input and output gain controls
- ◆ 48V phantom power, phase reverse switch
- ◆ 30dB mic pad; 90Hz low cut filter
- ◆ Drive & Signal level LEDs assist with gain setting
- ◆ Instrument DI inputs
- ◆ Balanced XLR mic input
- ◆ Balanced XLR line output (+4dB) duplicated on unbalanced jack connector (-10dB)
- ◆ Optional four channel 24-bit digital output

342

5013 2-Channel Tube Parametric EQ

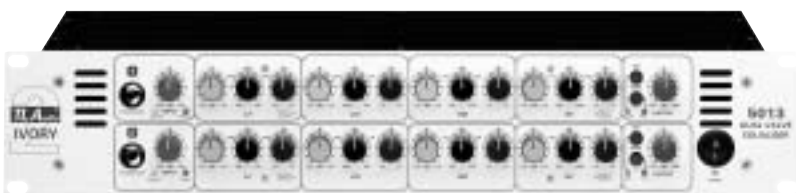

Offering the finest combination of performance and affordability, there is simply no EQ in this price range to touch it. And now the 5013 features a peaking/shelving option on both LF and HF bands plus a 'Fat' contour switch on both channels. Like all TL Audio equipment, the interfacing options couldn't be

more flexible - separate input and output level controls allow easy level matching with any other equipment, and a choice of balanced and unbalanced line inputs/outputs plus instrument DI inputs means you can get yourself up and running in seconds.

- ◆ Continuously variable input and output gain controls (-20dB to +20dB)
- ◆ Four bands of fully parametric EQ per channel: LF: 30Hz to 1kHz, LM: 100Hz to 3kHz, HM: 1kHz to 12kHz, HF: 3kHz to 20kHz
- ◆ EQ bypass switch on both channels
- ◆ Each band offers 15dB of cut or boost and variable Q (bandwidth) between 0.5 and 5
- ◆ Shelving mode available on LF and HF bands (by pulling out Q control)
- ◆ 'Fat' contour switch provides a gentle LF/HF lift combined with a mid cut, for extra warmth
- ◆ Front panel instrument input
- ◆ Drive and Peak LEDs
- ◆ Balanced XLR line inputs/outputs duplicated on unbalanced jack connectors
- ◆ Optional stereo 24-bit digital output

5021 2-Channel Tube Compressor

The 5021 provides first class audio quality, lots of flexibility and a price tag so modest, you'll think it was a mistake. Features include hard and soft knee modes, four attack and release times, an improved optical gate design and an optional digital output. It also uses TL Audio's own special transconductance amplifier design that avoids the use of VCAs - ensuring maximum audio transparency.



For Any Inquiries Regarding Your Order, Call Our Customer Service:
(800) 221-5743 • (212) 239-7765 • FAX: (800) 947-2215 • (212) 239-7549

- ◆ Each channel provides continuously variable control of: Input Gain, Threshold, Ratio, Gain Make-Up and Output Gain
- ◆ Four attack times: from 'Fast' (0.5mS) to 'Slow' (40mS)
- ◆ Four release times: from 'Fast' (40mS) to 'Slow' (4S)
- ◆ Hard/soft knee compression modes
- ◆ Automatic 'Hold' facility reduces LF distortion
- ◆ Optical gate with variable control of threshold (from -10dB to 'off')
- ◆ 'Bypass' and 'Stereo link' modes
- ◆ Switchable VU meters provide indication of output level or gain reduction
- ◆ Drive and Peak LEDs
- ◆ Front panel instrument inputs
- ◆ Balanced XLR line inputs/outputs duplicated on unbalanced jack connectors
- ◆ Sidechain insert points
- ◆ Optional 24 bit stereo digital output

5050 Tube Mic Preamp and Compressor



A simple yet great sounding tube front end, the 5050 boasts the winning combination of a mic/line/instrument preamp and mono compressor— making it the most cost-effective way of processing your sources. Features include a 30dB pad, hard/soft knee compression modes, a fully balanced line output and an optional digital output.

- ◆ The Preamp stage provides variable input gain, +48v phantom power, 30dB mic pad and 90Hz low cut filter
- ◆ Compressor section provides control of Threshold, Ratio, Gain Make-Up and Bypass
- ◆ Automatic "Hold" facility reduces LF compressor distortion
- ◆ Attack time switchable between 'Fast' (0.5mS) and 'Slow' (20mS)
- ◆ Release time switchable between 'Fast' (40mS) and 'Slow' (2S)
- ◆ Hard/soft knee compression modes
- ◆ Output fader permits complete attenuation through to +15dB of extra output gain
- ◆ Two 8-segment LED meters provide indication of output level & gain reduction
- ◆ Front panel instrument DI input
- ◆ Balanced XLR mic input
- ◆ Balanced 1/4" line input/output
- ◆ Optional 24-bit digital output

5051 Tube Channel Strip

The single channel voice processor format is a great way to get the most out of any sound source. The 5051 provides the perfect front end for any system by offering a combined preamp, compressor, EQ and noise gate in one easy-to-use package, plus an optional digital output. The 5051 compressor section is identical to that of the 5021 and includes hard/soft knee modes, and the four band EQ section is modelled after the legendary TL Audio EQ-1 —yielding superb results instantly, with an improved optical gate for removing unwanted source noise.

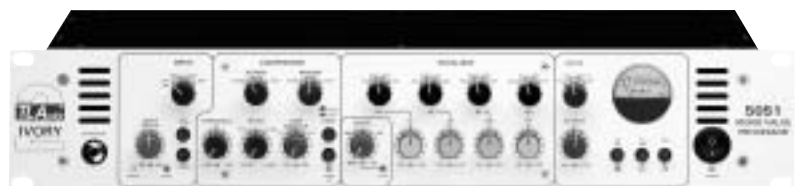

- ◆ Preamp stage: input gain, +48v phantom power, 30dB mic pad and 90Hz low cut filter
- ◆ Compressor section: control of Threshold, Ratio, Gain Make-Up and Output Gain
- ◆ Hard/soft knee compression modes
- ◆ Four switchable Attack times: 0.5mS to 40mS
- ◆ Four switchable Release times: 40mS to 4S
- ◆ Optical gate with variable control of Threshold (from -10dB to 'off')
- ◆ Instrument input; Balanced XLR mic input
- ◆ LF EQ band gives ± 12 dB shelving at 60Hz, 120Hz, 250Hz or 500Hz (12dB/octave)
- ◆ LM EQ band gives ± 12 dB peaking at 250Hz, 500Hz, 1kHz or 2.2kHz (Q=0.5)
- ◆ HM EQ band gives ± 12 dB peaking at 1.5kHz, 2.2kHz, 3.6kHz or 5kHz (Q=0.5)
- ◆ HF EQ band gives ± 12 dB shelving at 2.2kHz, 5kHz, 8kHz or 12kHz (12dB/octave)
- ◆ Switchable VU metering of input/output level or gain reduction; Drive and Peak LEDs
- ◆ 'EQ Pre' switch allows the EQ section to be placed ahead of the compressor section.
- ◆ 'Link' switch for stereo operation (two 5051s)
- ◆ Balanced XLR line input/output duplicated on unbalanced jack connectors
- ◆ Sidechain insert point
- ◆ Optional 24 bit digital output

5052

Dual Tube Channel Strip

The 5052 provides everything you would expect from a high quality 'channel strip' product, and then doubles it - making it the ideal system front end and the perfect stereo mixdown and mastering device. While most channel strip products provide a single mono channel made up of preamp, dynamics and EQ stages, the 5052 provides two channels of each with

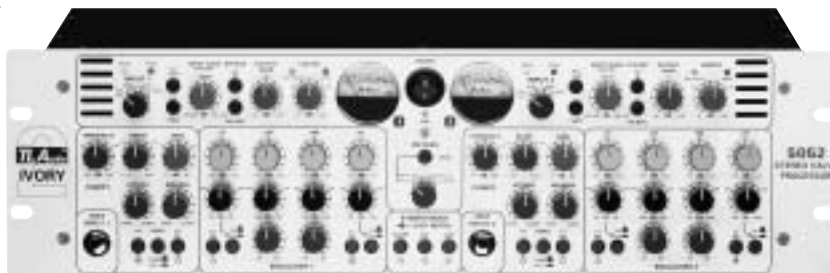

independent stereo linking of the compressor, EQ and limiter sections. Recording a stereo source to hard disc through the 5052 is simplicity itself, yet when it comes to mixdown the 5052 come into its own by offering full stereo linked EQ and dynamics, allowing unparalleled processing of the stereo mix buss signal while recording to 2-track.

Each channel of the 5052 boasts a tube preamp stage, a tube compressor, a four-band tube EQ section and a peak optical output limiter, with the following features:

- ◆ Preamp stage accepts mic, line and instrument inputs with variable input gain, 90Hz filter, 30dB pad and phase reverse.
- ◆ Compressor section offers variable threshold, ratio, attack, release and gain make-up controls, with hard and soft knee modes.
- ◆ Tube EQ section features swept LF and HF bands switchable between peaking and shelving modes, and two fully parametric mids. The EQ can be switched 'pre' or 'post' compressor, and can also be switched into the compressor sidechain for frequency conscious compression.
- ◆ Optical output limiter provides transparent brick wall limiting of the output signal, and provides a variable threshold control.
- ◆ VU metering is provided for input/output levels, and the gain reduction of the compressor and limiter stages can be separately monitored. A '+10dB' setting attenuates the meter reading to allow high input/output levels to be accurately tracked.
- ◆ The compressor, EQ and limiter stages can be individually stereo linked (channel A becomes the master, channel B the slave).
- ◆ Has an output level control, and a 'system bypass' switch allows A-B comparison of the original and processed signals.
- ◆ Full connectivity is built in, with balanced mic & line ins/outs (duplicated on unbalanced connectors), balanced inserts, compressor sidechain inserts and front panel instrument inputs.
- ◆ Optional DO-2 digital card provides 24-bit A-D conversion of the unit's main outputs, with switchable 44.1/48kHz sample rate and a word clock input.

VP-1 Tube Channel Strip



For those requiring an even higher quality channel strip, the VP-1 combines features from the TL Audio's classic PA-1 pentode preamp, C-1 compressor and EQ-2 parametric EQ. The VP-1 also

contains an expander/gate, a de-esser and an optical peak

limiter. The expander/gate, de-esser, compressor and EQ sections are all bypassable for easy A/B comparison. An optional 24-bit/96kHz digital output is also available.

Preamp stage accepts mic, instrument and line level signals. The mic input is transformer balanced and offers a choice of tube or class A signal paths. Switchable phantom power, phase reverse, 30dB pad and variable high pass filter are provided. Input gain is variable in 10dB steps with a 15dB trim control, and Drive and Peak LEDs indicate the level of tube drive and clipping respectively.

Expander/Gate offers precise and responsive VCA control of signal dynamics, and features fully variable adjustment of threshold, attack and release. A four segment bar graph meter indicates the degree of gain reduction.

De-esser employs high quality VCAs to allow effective but natural reduction of sibilance. De-esser depth, frequency and bandwidth are all fully variable. There is a bypass switch and status LED. Four segment bar graph meter indicates the amount of de-esser gain reduction.

Super-smooth compressor stage comes with both tube and optical compression circuits, and offers control of threshold, ratio, attack, release and gain make-up. Both hard and soft knee characteristics are provided, and a switchable 'Hold' circuit reduces LF distortion.

Sweetness and warmth comes via the 4-band tube EQ section, which utilizes four frequency LF/HF shelving as per the original EQ-1 equalizer, with two fully parametric mids identical to the EQ-2. The EQ can be switched 'pre' or 'post' the compressor stage.

8-Channel Precision Mic Preamp with M-S Decoding



With the emphasis shifting to digital audio platforms and modular configurations, software “plug-ins” are replacing many outboard signal processors. Other than the microphone itself, the mic preamp is the most significant analog device remaining in the signal chain. Designed to provide the detailed, transparent sonic performance necessary for the highest quality direct tracking and live sound applications, Precision 8, with its sonically pure design, simple-to-use features, and unparalleled cost/performance value, is the ultimate solution for state-of-the-art digital recording studios and project studios. Use as a complete input system for MDM’s, HDR’s, and DAW’s, Precision 8 is also ideal for location recording due to its 8-channel single rack unit format, smooth continuous gain controls, useful level metering, and easy interconnect. The integral M-S decoder provides creative spacial image control that is particularly useful in attaining an exciting stereo image with minimum effort and microphone repositioning.

FEATURES

- ◆ Eight highly transparent solid state mic preamps in a 1 unit rack configuration
- ◆ Challenges the recognized leaders in sonic accuracy and performance
- ◆ Two sonically accurate discrete FET instrument inputs (DI’s) are available for recording or live sound applications in which realistic, unaffected sound quality is desired.
- ◆ Built-in M-S (Mid-Side) decoding for creative spacial image control
- ◆ Smooth continuous gain controls
- ◆ 5-segment peak-hold level metering with selectable peak reference allows rapid optimization of program levels between the Precision 8 and devices to which it is interfaced.
- ◆ Easy interface to MDM’s, HDR’s, DAW’s, or consoles
- ◆ Dual DB25/TRS outputs for flexible interconnection
- ◆ Elegant, sturdy physical design
- ◆ Exceptional cost per channel value

P2ANALOG 2-Channel Microphone Preamp



A 2-channel microphone preamp designed to provide detailed, transparent sonic performance for the most critical direct tracking and sound reinforcement applications, the P2ANALOG features selectable M-S decoder, active DIs with impedance modification capability, dual gain range selection, selectable high-pass filters, and relay-switched signal routing. It also offers a Stereo Phase Correlation display that assists in optimizing microphone placement for stereo recording.

Modeled after the Precision 8, the P2ANALOG’s unique combination of functions make it a complete input system for standalone or PC-based recording systems. Hybrid, totally balanced, dual servo, high-voltage design provides top-notch transient response, headroom, imaging and noise performance. In addition to the acclaimed mic inputs, two instrument direct inputs (DI’s) offer incredible articulation and control for electric bass, detail and smoothness for stringed instruments and punchy, clean sound with keyboards.

	Precision 8	P2ANALOG
Gain (microphone)	+16 to +64 dB	3.5 to 52dB and 15.5 to 64dB
Gain (direct input)	-4 to +44 dB	-16 to 32dB and -4 to 44dB
Frequency Response (gain=40 dB)	1.5 Hz to 500 kHz (+0/-3 dB)	1.5 Hz to 500kHz (-3dB)(gain=40dB)
Maximum Input/Output Level	+15/31 dBu	+15/31 dBu
Input Impedance	5.5 kΩ(mic); 2 MΩ (direct input)	5.5 kΩ(mic); 2.5 MΩ (direct input)
Noise (Rs=0 Ohms)	-132 dB e.i.n.	-132 dB e.i.n.
Slew Rate	> 40 V/uS	> 40 V/uS
CMRR (CMV=+10 dBu):	85 dB	85 dB
Crosstalk	-130 dB	
THD (+26 dBu, 100 kOhm):	.0008%	.0008%

WAVES

L2 - Ultramaximizer

24-bit / 96kHz Hardware Limiter/Converter

The L2 Ultramaximizer is a 2U 19" rackmountable limiter and converter that combines refined look-ahead brick wall peak limiter algorithms and IDR (Increased Digital Resolution) dithering technology from the award-winning L1



software with 24-bit A-to-D and D-to-A converters, 48-bit internal processing and support for sample rates up to 96kHz. The L2's balanced XLR and RCA analog inputs and outputs, AES/EBU and S/PDIF digital I/O and a dedicated Word Clock input makes it compatible with a wide variety of audio applications, from tracking and mixing to mastering and concert sound. The L2's limiting capability can significantly increase the average signal level of typical audio signals without introducing audible side effects but is equally capable of extreme limiting, intentional pumping, and vintage dynamic processing effects. Additionally, L2's Increased Digital Resolution word length reduction system uses ninth-order noise shaping which can increase the perceived sound by as much as 18dB when dithering down from high resolution formats.

FEATURES

- ◆ Peak Limiter with 48-bit internal processing significantly increases the average signal level of typical audio signals without introducing audible side effects.
- ◆ Supports 44.1, 48 kHz, and x2 88.2 and 96 kHz sample rates at 24, 22, 20, 18 or 16 bit resolution.
- ◆ Linked stereo and dual mono operation.

L2 Limiter

- ◆ The use of look ahead technology allows the L2 to anticipate peaks before they happen, thereby minimizing the possibility of artifacts and can be used with absolute confidence in situations where brick wall limiting is critical.
- ◆ Dedicated front panel rotary controls accompanied by numeric displays include:
 - Threshold with a range of -30.0 to 0.0dB in 0.1dB steps.
 - Output Ceiling with a range of -30.0 to 0.0dB, in 0.1dB steps.

IDR Requantize, Dither and NoiseShaping System

- ◆ IDR (Increased Digital Resolution) is Waves' proprietary word length-reduction (quantization), dither and noise shaping technology which preserves and even increases the resolution of digital signals. For example, 16 and 20-bit masters can have the perceived resolution of 20 and 24-bit signals, respectively.

Inputs and Outputs

- ◆ 24-bit balanced XLR & unbalanced RCA analog inputs and outputs
- ◆ AES/EBU (XLR) and coaxial S/PDIF digital inputs and outputs
- ◆ Digital sync to AES/EBU, S/PDIF or from the dedicated Word Clock input (BNC)

- Variable Release Time (ARC control bypassed) with a range of 0.01 to 1000ms (logarithmic)
- ◆ ARC (Auto Release Control) dynamically controls release times to fit the human ear's expectations. This allows a greater amount of limiting and level maximizing without distracting artifacts.
- ◆ Dedicated bargraph meters for input, output and attenuation with infinite peak hold and peak reset buttons are also provided.

Applications

- ◆ For mastering applications, the combined effort of the L2's Ultramaximizer and IDR processing enhances the perceived sound quality by as much as 24dB.
- ◆ The limiter eliminates the danger of clipping when recording hotter signals – ideal for tracking and mixing as well as live sound or broadcasting.
- ◆ Requantize 24-bit input signals to 16-bit or 20-bit signal suitable for a wide array of today's recording equipment, such as DAT, 20-bit MO, CDR, etc.
- ◆ Additional applications include:
 - A-to-D and D-to-D mastering;
 - Digital recording 16 bit dithered / 24bit
 - Analog limiter insert;
 - Digital limiter insert,
 - A-to-D and D-to-A conversion

Technical Specifications:

Analog to Digital:

Frequency Response: 20 to 20k Hz (+0/- 0.01 dB)
Noise: -112 dBFS (18.3 bits)
THD: 3rd Harmonic -130dBFS, (@1kHz, -10dBFS)

Analog to Analog:

THD just below Clipping: < or = 0.0060%
Crosstalk: 99.5 dB (with full scale 1kHz source)
96kHz Freq. Response: 20 to 24.6k Hz (+0/- .5 dB)
-3 dB @ 45.2 kHz
44.1kHz Freq. Response: 20 to 20k Hz (+0/- .3 dB)
-3 dB @ 21.2 kHz



MAXXBASS 101 / MAXXBASS 102

Psychoacoustic Bass Extension Processors

MaxxBass 101 and MaxxBass 102 are bass enhancement hardware processors based on the MaxxBass software plug-in that has become a standard processing tool for computer based DAWs. Both

MaxxBass processors can add up to one and one-half octaves of bass extension without adding any distortion or stress to your sound system. In

just a few minutes the system can be tuned for optimum bass performance for a wide range of speaker types from desktop multimedia and museum installations to sophisticated club and house of worship sound systems. Both products provide a complete MaxxBass solution with a single set of input trim, frequency and intensity controls that adjust the left and right channels. The MaxxBass 101 is a 1U rack-mounting unit with balanced line level (+4dBu) analog I/O on XLR and TRS connectors and terminal blocks and the MaxxBass 102 is a half-rack unit with RCA connectors operating at -10 dBV.



FEATURES

- ◆ The MaxxBass processor is inserted in your system's signal chain between the audio source and amplifier
- ◆ A single set of controls are provided controlling both the left and right channels
- ◆ An Input Trim knob is provided for attenuating an incoming audio signal that is too hot. The 101 features a clipping indicator for the left and right channels. The 102 adds a signal present indicators.
- ◆ The Frequency knob allows you to tune the MaxxBass processor to the specific speaker system being used over a range of 25 to 100 Hz.
- ◆ The Intensity knob affects the amount of effect being applied allowing you to tune in the optimum bass level for your specific speaker system. As the Intensity knob is raised, the relative (to the original source frequency) level of harmonics increases and their decay rate becomes slower and more effect is mixed into the signal.
- ◆ The Bypass button, with status LED, allows you to turn the MaxxBass processing on and off for easy A/B comparison
- ◆ Once you have tuned your system with the parameter settings, you can disable the frequency and intensity controls and preserve the optimized settings using the system's fail-safe Lock button, accessed through a small pinhole. A Lock LED lights up to indicate that the unit is locked.
- ◆ The MaxxBass 101 is a 1U rack-mounting unit with balanced line level (+4dBu) analog I/O on XLR and TRS connectors and terminal blocks. The MaxxBass 102 is a half-rack unit with RCA connectors operating at -10 dBV
- ◆ Stereo analog inputs and outputs
- ◆ Both MaxxBass units are ideally suited for sound reinforcement and commercial sound installation applications including PA, clubs, houses of worship, restaurants, and retail stores, delivering richer, deeper bass without requiring larger, more sophisticated, or more expensive amplifiers and speakers.

MaxxBass Technology

MaxxBass is a patented psycho-acoustic bass frequency extension technology that provides perceived bass frequency response below the physical speaker cutoff in an audio system. MaxxBass utilizes the principle of the missing fundamental, which creates the sensation of low frequencies by generating a carefully calculated series of harmonics designed to simulate the auditory experience caused by the missing fundamental pitch. These harmonics extend the virtual frequency response up to 1½ octaves or two-thirds below the physical speaker cutoff frequency without perceived distortion or increased power consumption.

MaxxBass At Work

In the example below, MaxxBass is allowing the listener, using a multimedia speaker system, to perceive a 70 Hz tone even though the speaker is physically not capable of reproducing this frequency. The bass signal is analyzed by MaxxBass, which creates a carefully calculated series of harmonics of these low frequencies. The dynamics and the loudness of the original bass are duplicated in these harmonics to create the most natural-sounding enhancement of the original bass. High frequencies are merely passed to the output and added back to the signal.

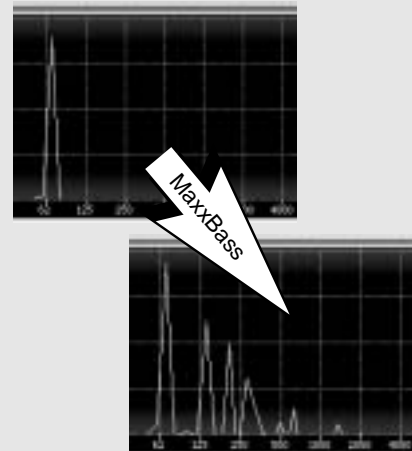

YAMAHA

REV100

Digital Reverberation Unit with 99 Programs

The Yamaha REV100 is an affordable, true stereo effects processor that offers a selection of 99 editable reverb programs in a single rack space. It offers

remarkably smooth, natural reverb sound as well as a range of other outstanding studio-quality effects including Stereo Reverb, Gated Reverb, Reverb plus Flanger, and Delays. The REV100 is designed to be super-simple to use — each of the 99 programs offers control of three parameters, including decay, delay time, and balance of wet and dry signal to allow you to build your own custom programs. The REV100 features dual 1/4" inputs and outputs and 16 bit A-to-D and D-to-A conversion at 44.1kHz. The REV100's MIDI In connector allows you to change effects programs using MIDI Program Change commands.



FEATURES

- ◆ Dedicated input level and wet/dry Mix controls.
- ◆ Peak LEDs make it easy to set the optimum input level.
- ◆ 99 high quality editable presets including true stereo reverb.
- ◆ The three most critical parameters for all effect programs can be adjustable via dedicated rotary panel controls
- ◆ Edited effects can be easily registered in memory via the stored button.
- ◆ Unbalanced 1/4" stereo (left and right) inputs and outputs.
- ◆ 16-bit A-to-D and D-to-A converters and a 44.1 kHz sampling rate provides full 20 Hz to 20 kHz frequency response with exceptionally low noise and distortion.
- ◆ Compact "1U" rack mount dimensions.
- ◆ Easy-to-read 2 digit LED display

Advanced MIDI Features

- ◆ You can select effect programs via MIDI rather than the panel controls. You can also use MIDI control change commands to actually change effect parameters.

Effect Categories

- ◆ Reverb Programs 1 - 20 – Includes essential reverb effects such as realistic hall, room, and plate reverb simulations
- ◆ Stereo Reverb Programs 21 - 40 – True stereo reverb effects that let you add ambiance to stereo signals without sacrificing the stereo image
- ◆ Gate Reverb Programs 41 - 50 – A range of "gated" reverb effects that add warmth and ambiance while maintaining a tight sound
- ◆ Delay Programs 51 - 60 – A selection of mono and stereo delay programs including straightforward one-shot repeats and complex bounce effects.
- ◆ Delay/Reverb Programs 61 - 70 – Combinations of delay and reverb that can add a little more life to your sound than delay or reverb alone.
- ◆ Reverb/Modulation Programs 71 - 99 – Reverb combined with a range of modulation effects including flange, symphonic, chorus, and tremolo.

99 Editable Presets - Exceptionally Easy Programming

The REV100 is basically a no-fuss signal processor - just select one of its 99 top-quality preset effects and you're ready to go. When you need something specially tailored to the occasion, however, the REV100 makes editing extra easy. The three most critical parameters for all effect programs are adjustable via rotary panel controls. No button-tapping to find or change settings - just rotate the appropriate controls until the sound is right. With reverb programs, for example, the panel controls give you direct access to the initial delay, reverb time, and high-frequency damping parameters - all you really need for full control. Input level and dry/wet balance controls are also provided. And when you create a sound you want to keep, just press the STORE button to register it in the REV100 memory. Of course, you can recall the original Yamaha presets whenever you like - either all at once or individually. Each of the parameter controls also has an LED that lights when the control setting matches the preset parameter value. The presets include reverb, delay, and modulation effects, plus a range of combinations so if you need reverb and flanging, for example, it's right at your fingertips.

Specifications

Frequency Response	20 Hz-20 kHz
Dynamic Range	80 dB (typical)
Distortion	< 0.1% (1 kHz, max. level)



Digital Reverberator

The REV500 is an affordable, high-quality, and easy-to-use digital reverb processor, well suited for home and project studio recording or live sound reinforcement applications.



The REV500's true stereo

processing capabilities delivers natural and spacious stereo reverb, as well as combinations of reverb with a variety of other effects. The 20-bit A-to-D and D-to-A converters and 32-bit internal processing ensure superb sound quality with a wide frequency response. The REV500 comes complete with 100 preset programs that exploit the potential of the high-performance DSP, plus there's room for 100 customized user programs. The REV500 is also flexible and simple to use. Both 1/4" phone and XLR input and output connectors are provided with the option of +4 dB input and output levels. Four rotary controls allow quick and easy editing of the basic program parameters. And MIDI In and Out terminals allow remote program selection, remote data storage, as well as realtime control and automation of program parameters.

FEATURES

True Stereo Processing

- ◆ 20-bit (64x oversampling) A-to-D and 20-bit (8x oversampling) D-to-A converters with a sampling rate of 44.1 kHz and the same 32-bit internal Digital Signal Processing (DSP) as the PROR3 provides superb sonic performance.
- ◆ True stereo reverb processing, with independent left and right channels.

Organized Program Libraries

- ◆ 100 Preset programs and 100 User programs are available divided into four easy to find categories of 25 presets each:
 - Hall** – Small, Medium and Large Halls, Churches, Concert Halls, Reverbs w/ Chorus and Flange, Gated Reverbs, Slapback and more.
 - Room** – Small, Medium and Large Rooms, Bathroom, Garage, Bright, Ambience, Tunnels, Opera, Cathedral, Live, Live Gate, Wood and more.
 - Plate** – Basic, LA Plate, Percussion, Long, Short, Vocal, Delayed Spring, Live, Cave, Fat, Thin, Light, Gated Plate, Plates w/ Symphonic, Chorus and Flange.
 - Special** – Variations of Flanging, Chorus, Dynamic Filters, Tremolo and Echo with Reverb.

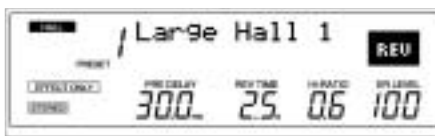

Intuitive User Interface

- ◆ An input level control accompanied by two four-segment LED level meters with clip indicators simplify level setting for optimal performance.
- ◆ A large custom multi-purpose LCD display provides information about the currently selected program and basic parameters being edited, as well as other messages related to utility functions.
- ◆ Dedicated rotary controls provide realtime control of the four most critical reverb parameters – Pre Delay, Reverb Time, Hi Ratio and Early Reflection Level.
- ◆ Internal editing parameters, specific to each effect algorithm, are easily accessed via the front panel Utility button and the four rotary controls.

Inputs and Outputs

- ◆ Left and Right balanced XLR and 1/4" inputs and outputs allow simple hookup to pro or semipro gear.
- ◆ Input and output levels for each channel are independently switchable between -10dB and +4dB.

MIDI

- ◆ The four basic parameter controls plus the output volume can be controlled in real-time via MIDI Control Changes.
- ◆ Program selection via MIDI is also supported as is MIDI Bulk Dump for user program backup.
- ◆ An optional footswitch with a 1/4" connector can be used to mute the reverb effect or advance through reverb programs.

Conveniences

- ◆ An Audition button to triggers a built-in snare and rim shot sample allowing you to instantly hear the effect of programs and edits directly from the front panel.

Specifications

Frequency Response	20 Hz to 20 kHz (+1.0 dB, -2.0 dB)
Dynamic Range	96 dB typical
Distortion Less Than	0.03% (1 kHz, max level)

YAMAHA

PRO R3

Digital Reverberator



The Yamaha ProR3 Digital Reverberator is a true stereo effects processor. It utilizes Yamaha's third-generation 32-bit digital signal processors (DSP) and high-performance 20 bit linear A-to-D and D-to-A converters to provide rich, high resolution reverbs, with breathtakingly dynamic impact. The high quality analog input

and output circuitry achieves a wide dynamic range of 110 dB, providing clean and natural sounding reverb right down to the final tail. The ProR3 is divided in two processing stages. The first stage features a choice of 10 primary effects including reverb, early reflection, room simulation, and combinations of reverb with echo, chorus, flanging, pitch change, and auto pan. The secondary stage features a chain of additional processors for fine tuning the primary effect. These include dynamic filter, compressor, EQ, gate, level, and balance stages. A pre-effect EQ is also provided for shaping the input signal. The ProR3 ships with 90 preset programs with room for an additional 90 user programs for storing customized settings. Both balanced XLR and 1/4" inputs and outputs are provided for connection to a variety of equipment. The ProR3 is an ideal choice as main or secondary reverb for any professional application.

FEATURES

- ◆ Third generation 32-bit DSP power has been coupled with 20-bit linear A-to-D and D-to-A converters to deliver unprecedented density, superior resolution and astonishing impact with a noiseless decay and a dynamic range of 110dB.

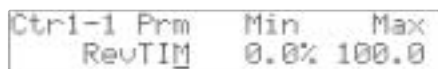

90 Presets and 90 User Memory Locations

- ◆ 90 factory presets are provided covering a wide range of applications – presets can be fine-tuned or completely re-programmed to create totally new effects. Edited effects can be stored in any of 90 user memory locations and instantly recalled.

Inputs and Outputs

- ◆ Electronically-balanced XLR and 1/4" input and output connectors – -10dB/+4dB level selectors on both the ins and outs provide level-matching flexibility.

Effects Stages

- ◆ Programs consists of two main stages; the primary effect and the secondary effects.
- ◆ Primary effects can be selected from one of the ten types divided into single effects and compound (multi) effect types, depending on the program that you select.

Single effect types include: Reverb, Early Reflection and Room Simulator

Compound effects types include:

Reverb+Echo, Reverb+Early Reflection, Reverb+Chorus, Reverb+Symphonic, Reverb+Flange, Reverb+Pitch, Reverb+Pan – you have control over the order in which compound effects occur (i.e. whether reverb comes before or after echo)

- ◆ There are 5 secondary effects provided for each program designed to shape and optimize the potential of the primary effects: DFL (dynamic filter), COMP (compressor), EQ, GATE, and LEVEL/BAL.

Dynamic Filter

- ◆ Versatile dynamic filter features low-pass, high-pass and band-pass modes with programmable center frequency, resonance, sensitivity, decay and shift direction.

Digital Pre-and Post-Reverb EQ

- ◆ 3-band sweepable pre-verb EQ controls with ± 15 db boost/cut are available right on the front panel for fast, easy access.
- ◆ The programmable Post-reverb EQ stage offers even greater control and versatility – 3 sweepable bands with a much broader frequency range, ± 15 db boost/cut and variable Q (bandwidth) parameters. The low and high bands can be each switched for shelving or peaking response.

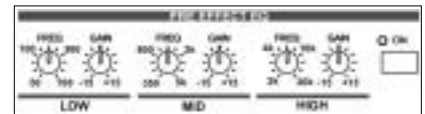

Built-In Dynamics

- ◆ The noise gate not only provides a simple threshold control, it also features a programmable trigger delay (0.1 to 100 ms), as well as adjustable hold and release times. Level detection can be carried out at the gate itself or at the pre-reverb signal – the gate can also be triggered via MIDI.
- ◆ A precision compressor is provided with variable threshold, output level, ratio, attack and release time parameters as well as selectable knee (soft, normal or hard).



ONE HOUR FREE PARKING

AT 349 W. 34th STREET (with purchase of \$100 or more)

User Interface

- ◆ The large 24-character x 2-line backlit LCD displays multiple related parameters at once for easy programming and operation including the name of the selected program and the program parameter values
- ◆ A dual concentric knob allows you to adjust the input level independently for the left and right channels
- ◆ Two 8 segment LED meters indicate accurate, pre A-to-D input levels, from -36dB to Clip, for each channel
- ◆ A two-digit seven-segment display indicates the currently selected program number – two LEDs indicate whether programs are loaded from Preset or User locations
- ◆ The Parameter keys provide direct access to the current effects' parameters, the post-EQ and Gate processors, level/balance parameters and MIDI controller assignments. Each time a key is pressed, it will cycle through the parameter pages
- ◆ The Data keys (INC) (DEC) allow you to modify the value of the selected parameter while the Cursor keys are used for navigating to parameters displayed in the LCD
- ◆ The Numeric keypad is used to directly input the a program number for recall, or direct input of parameter values
- ◆ The Main key accesses an effects most common parameters (Rev Time, Pre Delay and Hi and Lo Ratio), while the Fine Key accesses a program's more detailed parameters like density and liveness etc...
- ◆ The Compare function allows instant A/B comparison between the original and an edited sound
- ◆ The Infinite key, when pressed, will dramatically lengthen the RevTime parameter producing the effect of a "freeze-frame" or "stop-motion" sound
- ◆ MIDI In/Out/Thru connectors support program change and program dump – up to 2 different effect parameters can also be controlled via MIDI in real time – if MIDI data is being received from an external device connected to the MIDI In connector the MIDI indicator will light
- ◆ There are four user-selectable input modes – Stereo, LR/Mix, R-Mono, L-Mono

Signal Flow of the ProR3's Primary and Secondary Effects Stages

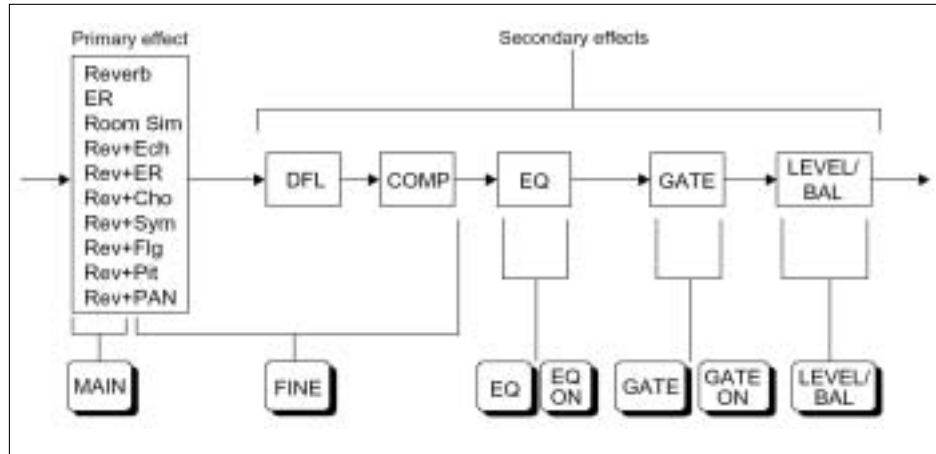

Reverb Types

- ◆ Reverb parameters are based on 2-stage reverb processing designed to achieve extremely smooth, natural reverb and allows true stereo reverb if required. There are a total of 9 reverb algorithms available including: Small Hall, Large Hall, Vocal plate, Perc.Plate, Spring, Echo Room, Strings, Snare and Reverb Flange.
- ◆ Early Reflections parameters include 6 preset early reflection types and 4 "user" types that can be created with customized individual reflection levels and pan positions.
- ◆ Room Simulator parameters are essentially basic reverb programs, configured with a range of parameters which allow you to control the dimensions and characteristics of a simulated room.

Compound Effects

- ◆ All compound effects are available in three patches configurations: series effect to reverb, series reverb to effect and parallel effect with reverb.
- ◆ Echo + Reverb parameters are one of the most commonly combinations used in recording and live sound applications
- ◆ Early Reflections + Reverb Parameters are ideal for producing exceptionally natural-sounding ambience effects
- ◆ Chorus + Reverb; Symphonic + Reverb; Flange + Reverb Parameters combine outstanding reverbs with chorus, symphonic and flange type modulation, making it easy to add a subtle touch of animation to the reverb sound or produce wild effects
- ◆ Pitch Change + Reverb Parameters — Pitch change capability can be extremely useful for creating artificial harmonies, or adding a subtle extra touch of high or low end to the basic sound. The pitch change portion of this program allows two pitch variations to be created in addition to the original sound. The series patches allow the reverb sound to be pitch-changed, while the parallel patch allows the original sound to be pitch-changed independently from the reverb effect.
- ◆ Pan (Auto-Pan) + Reverb Parameters form a useful combination for many applications

Specifications

Frequency Response	20 Hz - 20 kHz (+1.0 dB, -1.5 dB)
Dynamic Range	110 dB (typical), not less than 104 dB
Hum and Noise	< -80 dB
Distortion	< 0.007% (1 kHz, maximum level)