

## MONSTER-POWER Pro AVS 2000

#MOPAVS2000  
**\$1699<sup>95</sup>**



The Pro AVS 2000 is a six-outlet rack mount Automatic Voltage Stabilizer designed to maintain constant voltage to audio gear and prevent power-line fluctuations in professional and commercial studios or high-end home theater installs. The unit provides auto-correction for voltage spikes and dips, supporting a wide 80V to 140V range, and, at close to 70 lbs, is built like a tank.

- (4) switched, (2) unswitched power outlets
- Sequential powering with programmable delay prevents on/off pops
- Safety Overload Sensor for extreme overload gear disconnect
- (3) separate meters monitor incoming voltage, amperage draw, voltage correction
- Heavy-duty 12-ft., 12-gauge AC power cord

## MONSTER-POWER Pro 1000

#MOP1000FSPC  
**\$149<sup>95</sup>**



More than a simple power strip, the Pro 1000 is a complete floor-standing power center that uses the same noise suppression and surge protection technology that Monster has made available in their rack-mountable units. This piece is the perfect addition to any performing musician's live rig and can be used to protect sensitive studio gear and mobile systems as well.

- (8) color-coded switched AC outlets
- Current and voltage availability LED bar graph meters
- Ground, wiring fault, and surge protection indicators with alarm
- Aluminum exterior with rubberized end caps
- Heavy-duty, 10-ft. shielded power cord
- Stage 2 isolation filtering with 2775 joule rating

## MONSTER-POWER Pro 7000

#MOP7000RPC  
**\$1499<sup>95</sup>**

The Pro 7000 is a top-of-the-line rack-mountable power management system that delivers clean, balanced AC to your studio environment. Twelve specially-tailored outlets provide isolated surge protection and filtering for analog, digital, high power, and computer-based equipment, giving you maximum rejection of unwanted noise-producing interference.



- (6) switched or unswitched outlet pairs
- Defeatable voltage alarm for over- or under-voltages
- Programmable power-on sequencing
- Ground, Surge, AC Filtering, and Abnormal Voltage LED's
- Extra long 8-ft. PowerLine 300 ultra-high current power cord
- Rear connections for optional Monster FlexLamp
- Stage 5 isolation filtering with a 3145 joule rating

**Monster FlexLamp** gooseneck workspace illumination #MOMPLMPXLR5.. **\$39.95**

## MONSTER-POWER Pro 3500

#MOP3500RPC  
**\$299<sup>95</sup>**



The Pro 3500 is a low-noise, 12-outlet power distribution system in a package perfectly suited to studios, performing musicians, techs, and almost any live or installed

application. Isolation between the digital and analog filtered output sections prevents audible interference from reaching adjacent outlets easily, keeping your system noise down and allowing your gear to sound its best.

- (12) switched rear and (2) unswitched front panel outlets
- Three-stage sequenced AC power turn-on and turn-off
- Digital meter for available voltage and current demand
- Separate digital, analog and high power output sections
- Front and rear connections for optional Monster FlexLamp
- Stage 3 isolation filtering with 2775 joule rating

**Monster FlexLamp** gooseneck workspace illumination #MOMPLMPXLR5..... **\$39.95**

## MONSTER-POWER Pro 2500

#MOP2500RPC  
**\$199<sup>95</sup>**



The Pro 2500 is a single rack space surge protector and AC filtering system that brings Monster quality within reach of anyone in search of clean, noise-free power. The 8 switched rear outlets are color-coded while the front panel offers 2 easily accessible unswitched outlets to make setups quick and painless.

- (8) switched rear and (2) unswitched front panel outlets
- Two-stage sequenced power turn-on and turn-off
- Three-character LED for AC voltage monitoring
- Heavy-duty, 8-ft. PowerLine 200 power cord
- Front connections for optional Monster FlexLamp
- Stage 2 isolation filtering with 2775 joule rating

**Monster FlexLamp** gooseneck workspace illumination #MOMPLMPXLR5..... **\$39.95**

**FURMAN****AR-1215**#FUAR1215  
**\$549<sup>95</sup>**

The AR-15 is a professional rack-mounted AC line voltage regulator designed to protect equipment from voltage irregularities such as brownouts or over-voltages, and provide a steady, stable 120 VAC output. The "Extreme Voltage Shutdown" feature senses dangerously high or low voltages and shuts down the output before malfunctions or permanent damage sensitive digital equipment.

- (8) rear panel outlets and one front panel outlet
- Delivers a stable 120  $\pm$ 5VAC whenever the input line voltage is between 97V and 141V • Output capacity: 15 amps
- 10-LED bar graph input voltage meter
- Extreme voltage shutdown indicator LED • Circuit breaker on/off switch

**FURMAN****IT-20II**#FUIT202  
**\$1699<sup>95</sup>**

The IT-20II powering system feeds balanced and noise-free AC to your recording studio, broadcast station, or video production facility with failsafe construction and maintenance-free operation.

Balanced power all but eliminates inducted hum between connected devices, while multi-stage voltage suppression and extreme voltage shutdown circuitry protect your investments.

- 20 amp capacity with constant 120V output within capture range • (12) rear isolated ultra-low resistance Hubbell outlets • (2) front GFCI protected 20 amp outlets
- Ground lift switch to eliminate AC hum and ground noise • Provides over 80dB of common mode noise rejection • Protection and voltage overload indicators with voltmeter

**Furman RRM-2** rear rack-mount ears for AR-1230 #FURRM2AR1220.....**\$69.00**

**Furman ADP1520** 20 to 15 amp plug adaptor #FUADP1520.....**\$18.00**

**FURMAN****AR-20 II**#FUAR20II  
**\$1399<sup>00</sup>**

The AR-20 II is a professional 20-amp voltage regulator that transforms the irregular fluctuations from your incoming AC into a constant



120V stream, keeping sensitive electronic gear running smoothly. Housed in a sleek and sturdy 2 rack space chassis, it is designed to be a simple and maintenance-free surge suppression system, AC filter, and stable power source.

- 20-amp capacity with optional 15-amp adaptor plug
- (12) rear and (2) front panel regulated outlets
- Three character-selectable voltage/current meter
- Regulation, protection, and extreme voltage indicators
- The only 20-amp regulator with noise filtering

**Furman ADP1520** 20 to 15 amp plug adaptor #FUADP1520.....**\$18.00**

**FURMAN****PlugLock**#FUPLUGLOCK  
**\$39<sup>95</sup>**

The PlugLock is an inexpensive outlet strip with outlets spaced widely enough apart for bulky "wall wart" transformers. Easily secure cumbersome power supplies with the locking adjustable clamps.

- Mounts safely out of sight, in the back of your rack
- Can lock regular plugs as well as wall warts
- Heavy-duty, 5-ft. 14 AWG 3-conductor power cord
- Rated for 15 amps with circuit-breaker protection
- Clamps adjust from 0.4"– 2.1" above outlet
- All-steel construction

**FURMAN****Power Factor Pro**#FUPFPRO  
**\$379<sup>95</sup>**

Furman's Power Factor Pro Conditioners are specifically designed to provide clean power for guitarist, bassist, and keyboard players. Clubs, bars, and rehearsal rooms are notorious for having less than reliable AC power, and the Power Factor Pro use specialized technologies to optimize it for musician's specific needs. The Power Factor Pro features: Clear Tone Technology, SMP+ (Series Multi-Stage Protection Plus), LiFT (Linear Filtering Technology), and E.V.S. (Extreme Voltage Shutdown) over voltage circuitry.

- 4 Rear outlets • Line Voltage Meter
- Master switch controls all outlets
- Series Multi-Stage Protection (SMP)
- Automatic Extreme Voltage Shutdown (EVS)
- Zero ground contamination circuitry

## RAXXESS PD-800VM



#RAPD800VM  
**\$104.95**

The PD-800VM is a high-quality, economical rack-mounted power conditioner with eight rear-panel outlets, surge/spike protection, and front-panel voltage metering. Featuring two front panel pull-out lights with an on/off switch, the PD-800VM provides a convenient light source for both stage and studio racks.

- (8) evenly-spaced outlets (accepts wall warts)
- 15-amps rating
- Front-mounted circuit breaker
- RFI and EMI surge protection
- 12-ft., 14-gauge power cord

**PD-800L** same as PD-800VM, but without front voltage metering #RAPD800L..... **\$87.50**

**PD-800** same as PD-800L, but without front panel lights #RAPD800..... **\$64.95**

## ALESIS PowerTrip8



#ALPOWERTRIP8  
**\$99.00**

The PowerTrip8 is an 8-outlet single rack space power module that is an ideal control unit for any rackmount system. The fast-acting surge suppression responds in less than a nanosecond and the interference filtering works to prevent radio or electromagnetic waves from entering your system, which would normally cause audible noise.

- (8) outlets with high-voltage surge and transient suppressor
- Front-panel LED voltage meter with bright, clear display
- Two pull-out light bars (with dimmer) illuminate entire rack
- RFI and EMI filtering keep unwanted noise out of your system
- Single rack space makes it an easy addition to your system

## FURMAN PS-Pro II



#FUPSPROII  
**\$319.00**

The PS-Pro II is a rack-mounted power conditioner/sequencer capable of powering up a rack full of equipment in a three-step delayed sequence (the sequence is reversed for power-down). It features comprehensive surge suppression and line noise conditioning, nine outlets, and a BNC jack for attachment of a gooseneck lamp.

- (6) switched outlets (on rear panel), and (3) unswitched outlets (one front, two rear)
- SMP+ (Series Mode Protection Plus) non-sacrificial surge suppression
- LiFT (Linear Filtering Technology) with zero ground contamination
- Extreme voltage shutdown • Capable of remote remote operation
- 10-ft., 12-gauge, heavy-duty power cord

## FURMAN PL-PRO II, PL-PRO D II, PM-PRO II



#FUPLPROII  
**\$319.95**

#FUPLPRODII  
**\$324.95**

#FUPMPROII  
**\$374.95**

The 20-amps PRO II series rack-mounted power conditioners offer Furman's most comprehensive protection from power line-related transient voltages, noise, and wiring faults. These top-of-the-line conditioners all provide eight switched rear-panel outlets and one unswitched front-panel outlet.

**PL-PRO II:** features a 20-segment incoming AC line voltage meter  
**PL-PRO D II:** features an ultra-accurate, front-panel digital AC meter  
**PM-PRO II:** features ultra-accurate, front-panel digital AC and current meters

- PL-PRO II and PL-PRO D II have (2) front-panel retractable lights w/dimmers
- 20-amps rating • SMP+ with Extreme Voltage Shutdown guards against destructive wiring faults • LiFT (Linear Filtering Technology) with zero ground contamination
- Heavy-duty 10-ft., 12-gauge power cord

## FURMAN Merit Series

#FUM10  
**\$39.95**

#FUM8  
**\$54.95**

#FUM8L  
**\$84.95**

#FUM8D  
**\$119.95**



The affordable Merit Series rack-mounted power conditioners/light modules are available in four models, each with eight switched outlets on the rear panel, and an additional one on the front (the M-10, which has ten rear panel outlets only). The M-8L and M-8D feature two slide-out swiveling light fixtures, and the M-8D adds a bright red, three digit LED meter that displays incoming AC line voltage. The M-8 is designed for applications where lights are not required.

- Fast-acting transient voltage suppression and RFI/EMI interference filter
- AC Voltmeter (if present): Range 60 to 150VAC; accuracy  $\pm 2\text{VAC}$
- Separate "Rack Lights" switch and dimmer control knob for lamps (if present)
- Circuit breaker provided with push-button reset
- Maximum output current: 15 amps • Heavy-duty, 6-ft., 14 AWG 3-conductor power cord

**MONSTER-POWER**

**Pro 800**

The Pro 800 is a well thought-out surge protector that fits easily into any gig bag, giving you the assurance of protected AC wherever you may need it. Well-labeled outlets, room for bulky power supplies, and gold-plated contacts for maximum power transfer help put it in a class above the everyday power strip.

#MOP800HPPC  
**\$79<sup>95</sup>**

- (8) color-coded outlets for easy gear identification
- Audible and visible indicators for ground and surge protection
- Flat plug exhibits lower profile
- Heavy-duty, 10-ft. shielded power cord
- Stage 1 isolation filtering with 1850 joule rating



**FURMAN**

**PST-8**



The Furman PST-8 is a portable surge protector and AC filtering system that goes well beyond what is

found in traditional power strips. Unlike Furman's latest advances in AC conditioning, ordinary units make use of older technologies that may not only leak voltage to circuit ground, but provide uneven noise filtering. With the PST-8, it is possible to have clean and quiet AC power anywhere.

- (8) linearly filtered outlets, two of which accept wall-wart power supplies
- Highly visible protection-ok and extreme voltage indicators
- Transient voltage surge suppression for telephone, cable, and satellite lines
- Zero ground contamination assures clean power to critical audio/video gear
- Extreme-voltage shut-down circuit prevents AC overload damage

#FUPST8  
**\$135<sup>00</sup>**

**Furman PST-6** (6) filtered outlet version #FUPST6 ..... **\$85.00**

**HOSA**

**PWA-421**

**IEC Female to 3-Prong male adapter**

The PWA-421 is an adapter that allows any standard 3-Prong extension cord to be turned into an IEC cable for amps, powered monitors, mixers, keyboards, etc.

#HOPWA421  
**\$3<sup>49</sup>**



**HOSA**

**PWD-401**

**Multi-Head Power Cord**

The PWD-401 is a unique power cord that provides an additional 3-Prong outlet from equipment powered by IEC cables, and can be used to clean up racks by daisy-chaining multiple PWD's together.

#HOPWD401  
**\$6<sup>95</sup>**



- 1-ft., 14-gauge cord • 15-amps rating, Voltage rating 125V
- Also available in 2-ft. length (PWD-402)

**MONSTER-POWER**

**Outlets To Go**

**4 Outlets**

#MOMPOTG400WH  
**\$19<sup>95</sup>**



If you are a traveling musician you already know that hotel rooms and makeshift laptop recording locations never seem to offer enough AC outlets to connect all your gear. The Outlets To Go series from Monster allows you to pack more AC connectivity conveniently into an ultra-thin design that you can tote easily in your gear bag. It also includes a FlatProfile Plug and FlatWrap Cord for even more space savings.

- (4) outlet ultra-compact design
- Resettable circuit breaker protection
- Blue illuminated plug indicates On status
- Cord management eliminates dangling cables

**Monster Outlets To Go 6 Outlets** (6) outlet version of above #MOMPOTG600WH ..... **\$29.95**

**MONSTER POWERLINE**

**200 IEC**

**power cord**

#MOPL200PRO8  
**\$49<sup>95</sup>**



- High-performance power connection for A/V components
- 24k gold-plated contacts for maximum conductivity
- 100% mylar foil shield for superior rejection of EMI and RFI
- 8-ft. length

**MONSTER POWERLINE**

**100 IEC**

**power cord**

#MOPL100PRO8  
**\$29<sup>95</sup>**



- Improved power connection for A/V components
- 24k gold-plated contacts for maximum conductivity
- Heavy-duty Duraflex jacket for protection from snags, kinks, and tears
- 8-ft. length

**RADIAL ENGINEERING****J48**

Active direct box ideally suited for studio, broadcast, and stage use.

- Active 48V phantom-powered direct box
- Minimal power draw with high-rail voltage
- Will not choke when driven hard
- Low inter-modulation distortion



#RAJ48  
**\$199<sup>99</sup>**

**RADIAL ENGINEERING****JDI**

High-quality passive direct box for critical recording or live performance applications.

- Jensen Transformer equipped passive DI
- 100% isolation eliminates ground loops
- Virtually zero phase & harmonic distortion
- Exceptional signal handling
- High common mode noise rejection

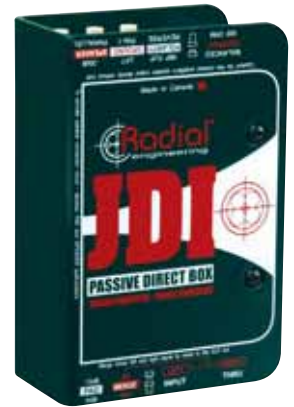

#RAJDI  
**\$199<sup>99</sup>**

**RADIAL ENGINEERING****JPC****Stereo PC-A/V Direct Box**

Stereo direct box specifically designed for use with computer sound cards and consumer electronic products

- Stereo DI for computer sound cards & A/V
- Transformer isolation eliminates ground loops
- Converts -10dB to balanced XLR mic level
- Active drive circuit for long cable runs
- 48V phantom power eliminates batteries

#RAJPC  
**\$199<sup>99</sup>**

**PRO-CO****DB-1**

Passive direct box with speaker/line-level attenuator, high-cut filter, and ground lift switches

- Floating transformer-balanced XLR output for maximum isolation
- SPKR (speaker) mode handles amplifiers up to 600 watts
- High-cut filter reduces distortion
- Ground lift switch eliminates hum and buzz
- Passive design requires no batteries or phantom power

#PRDB1  
**\$99<sup>95</sup>**

**BBE****DI 1000**

A high-quality active/passive DI with built-in Sonic Maximizer, and Jensen output transformer

- Jensen JT-DB-EPC Transformer for warmth and presence
- Purely passive or completely active operation
- Switchable 0/15dB/30dB pad switch
- Ground lift switch
- Balanced XLR Output



#BBD1000  
**\$249<sup>99</sup>**

**PRO-CO****CB-1**

Passive direct box with ground lift switch and high-cut filter

- Single-channel passive direct box
- Floating transformer-balanced XLR output for maximum isolation
- High-cut filter reduces distortion
- Ground lift switch eliminates hum and buzz
- Passive design requires no batteries or phantom power



#PRCB1  
**\$59<sup>50</sup>**

**BBE****DI100X**

Professional-grade active DI box with a built-in Sonic Maximizer processor

- Built-in, full-function BBE Sonic Maximizer
- 15dB pad switch
- Ground lift switch
- Electronically-balanced XLR output
- Recessed switches to reduce the opportunities for damage

#BBD100X  
**\$149<sup>99</sup>**

**BEHRINGER****ULTRA-DI DI100**

Economical, rugged DI Box for stage and studio applications

- Internal battery automatically shuts off when phantom power is connected
- Direct connection of amplifier outputs with ratings of up to 3,000 watts
- Switchable input attenuation
- Ground lift switch

#BED100  
**\$39<sup>99</sup>**

**WHIRLWIND****Direct 2**#WHD2  
**\$132<sup>95</sup>**

Two-channel direct box for converting unbalanced stereo signals from keyboards, CD and tape players, and computer sound cards

- 1/4" parallel wired in/out jacks
- Ground lift switch to help eliminate hum and buzz
- 20dB pad switch for connection to "hot" input signals

**WHIRLWIND****HOTBOX**#WHHB  
**\$126<sup>95</sup>**

High-quality active direct box that operates with batteries or phantom power

- Super-clean front-end circuitry
- 1/4" parallel wired in/out jacks
- Ground lift switch to help eliminate hum and buzz
- Input switch selects between instrument/line or speaker level input signals
- LED indicates "ON" status

**WHIRLWIND****DIRECTOR**#WHD  
**\$82<sup>95</sup>**

Direct Box with 30dB pad and high-cut filter switches for studio or PA applications

- 1/4" parallel-wired in/out jacks
- Ground lift switch helps eliminate hum and buzz
- 30dB pad switch for selecting between line/instrument or speaker level input signals
- Switchable high-cut filter

**COUNTRYMAN****Type 85**#CODB  
**\$159<sup>95</sup>**

High-quality direct box with top-quality components and Class-A circuitry

- Single-ended Class-A circuit
- Internal electronics are molded into a solid epoxy block
- Ground lift switch eliminates noise and buzz
- Pickup mode and Speaker mode switch allows -10dB and -46dB operation
- Powered via phantom or internal 9V battery

**WHIRLWIND****IMP 2**#WHIMP2  
**\$41<sup>95</sup>**

Built ruggedly on the inside and outside, the world-famous IMP 2 DI is found in pro systems everywhere.

- 1/4" parallel wired in/out jacks with XLR output
- Transformer is riveted, not glued, to the chassis
- Professional quality and durability

**BSS AUDIO****AR-133**#BSAR133  
**\$169<sup>95</sup>**

The AR-133 is an active audio direct box and line balancer. The unit is powered by either a 9-volt battery or phantom power.

- Rugged aluminum chassis
- Ground-lift switch
- Input pad switch with switchable 0, -20, or -40dB attenuation
- God for keyboards, amplifiers, or electric guitars and basses

**WHIRLWIND****PCDI**#WHPCDI  
**\$139<sup>95</sup>**

Direct box with RCA connectors designed to interface unbalanced stereo line sources with professional, balanced, low-impedance equipment

- Color-coded RCA phono in/thru jacks
- Color-coded XLR output jacks
- Ground lift switch to help eliminate hum and buzz
- 20dB pad switch for connection to "hot" input signals

**ART****X-DIRECT**#ARXD  
**\$40<sup>00</sup>**

Single-channel phantom or battery-operated active Direct Box

- 1/4" TRS and XLR inputs/ XLR output
- Powered via internal 9V battery or phantom power
- The Input Attenuator switches allow for a wide range of signal levels
- Switchable low-pass filter
- Phase invert switch
- Compact, black, anodized all-aluminum case

## ROLLS SE162

The SE162 Red Square is an instrument direct box/impedance-matching device with a sonic exciter built in.

- (1) 1/4" input and (1) XLR and (1) 1/4" output
- Bypassable sonic exciter with Bottom control
- Definition control adjusts presence



#ROSE162  
**\$82<sup>50</sup>**

## TAPCO DB-1A

The DB-1A is an Active direct box that can be powered either internally by two 9-volt batteries or externally by phantom power from a mixer.

- 1/4" input and (1) XLR output
- Convenient stackable design
- Ground lift helps eliminate buzz and hum



#TADB1A  
**\$49<sup>99</sup>**

## WHIRLWIND EDB1



The EDB1 is an economical direct box offering rugged construction while maintaining exceptional sound quality.

- Pad switch for connection to "hot" signal sources
- Metal construction and quality transformer
- Ground Lift switch to help isolate hum and buzz

#WHEDB1  
**\$28<sup>50</sup>**

## HOSA DIB-307A



The DIB-307A boosts guitar and bass signals up to line level for direct-to-mixer connections via either Low-Z or Hi-Z inputs.

- Amplifier speaker output may be routed to console
- Ground Lift Switch reduces 60-cycle hum.
- Rugged die cast aluminum chassis for durability

#HODIB307A  
**\$79<sup>95</sup>**

## BEHRINGER ULTRA-DI DI20

The ULTRA-DI DI20 is an active 2-channel direct DI-box and splitter that may be powered by 9V battery or phantom power.

- Up to 40dB of input attenuation
- Split mode allows 3-way output
- Ground lift eliminates ground loop problems



#BEDI20  
**\$29<sup>99</sup>**

## RADIAL ENGINEERING Pro48

The Radial Pro48 is a high-performance 48V phantom-powered active direct box designed specifically for higher-output instruments. This box is perfect for battery-powered active basses and acoustic guitars that tend to overload other direct boxes.

- Compact, rugged book-end design
- Increased dynamic range and headroom
- 48V phantom-powered with digital switching



#RAPRO48  
**\$139<sup>99</sup>**

## WHIRLWIND Direct-JT

Whirlwind's top-of-the-line passive DI features the Jensen JT-DB-EPC transformer—world renowned for wide frequency response and superior noise rejection characteristics.

- Extruded aluminum housing
- Thru output passes signal to second destination
- Selectable speaker emulation



#WHDJT  
**\$175<sup>95</sup>**

## WHIRLWIND Direct2-JT

The DIRECT2-JT is Whirlwind's premium passive Dual Direct box, built with Jensen transformers.

- Isolated grounds for each section
- Combine button creates dual inputs per channel
- -20dB pad for handling hot signals



#WHD2JT  
**\$339<sup>95</sup>**

**RADIAL ENGINEERING**

**ProDI**

#RAPRODI  
**\$99<sup>99</sup>**

The Pro DI full-range passive direct box is equipped with custom-made audio transformers for exceptional signal handling without saturation.

- Isolation transformer eliminates noise
- Compact and rugged design
- Ideal for live and studio



**RADIAL ENGINEERING**

**ProD2**

#RAPROD2  
**\$149<sup>99</sup>**

The dual-channel ProD2 delivers exceptional clarity and definition at an attractive price point.

- Very low harmonic and phase distortion
- Made of 14-gauge steel for extreme durability
- Ideally suited for acoustic guitar, bass, and keyboards



**ROLLS**

**ADi6**

#ROADI6  
**\$64<sup>95</sup>**



The ADi6 is an active direct box designed to convert a high-impedance signal and convert it to low impedance.

- Paralleled or Mix Inputs
- Variable Attenuation
- Ground Lift
- Battery or Phantom Power operation

**WHIRLWIND**

**Direct4**

#WHD4  
**\$279<sup>95</sup>**



The Direct4 is a floor-style direct box that houses four completely separate DIs in a single rugged casing.

- Extremely durable casing with solid transport handle
- Isolated grounds for each section
- Filter switch to help reduce amplifier noise and hiss

**BEHRINGER**

**ULTRA-DI DI4000**

#BEDI4000  
**\$79<sup>99</sup>**



The DI4000 is a 4 channel multi-purpose DI for stage and studio applications that features its own internal power supply.

- 8-segment LED level metering
- Switchable High Cut filter on each channel
- Illuminated switches for dark stage environments

**WHIRLWIND**

**HotBox Quad**

#WHHBQ  
**\$479<sup>95</sup>**



The HotBox Quad features 4 channels of super-clean active DI performance in a 1U rack package with built-in power supply.

- Roadworthy construction
- 1/4" parallel wired in/out jacks with XLR output
- Signal and Clip indicators on every channel

**WHIRLWIND**

**MultiDirector**

#WHMLTDIR  
**\$279<sup>95</sup>**



The MultiDirector represents 4 DIs housed in one convenient 1U rack package and is the touring sound standard for passive direct boxes.

- Passive unit requires no power
- -20dB pad available for all inputs
- (4) Color coded XLR outputs

**PRO CO**

**DB-4A**

#PRDB4A  
**\$284<sup>95</sup>**



The DB-4A provides four independent direct box channels in a convenient single rack space unit.

- (4) floating transformer-balanced XLR outputs
- Perfect for keyboards, drum machines, etc.
- Line mode handles signals up to +34dBv

**AUDIO-TECHNICA****AT8801****Single-channel 48V Phantom Power Supply**

The AT8801 provides 48V phantom power for a single microphone.

- Highly-regulated power supply provides a constant voltage source
- Rugged steel case
- Includes a plug-in power module w/6-ft. cable



#AUAT8801  
**\$62<sup>95</sup>**

**AUDIO-TECHNICA****CP8506****Four-channel 48V Phantom Power Supply**

The CP8506 provides 48V phantom power for up to four condenser microphones.

- Highly-regulated power supply provides a constant voltage source
- Rugged steel case
- Includes an attached 6-ft. ground-line cord w/ power switch



#AUCP8506  
**\$139<sup>95</sup>**

**ART****Phantom II****2-Channel Battery-Operated Phantom Power Supply**

The PHANTOM II is a 2-channel portable phantom power supply with XLR connectors that operates on two 9V batteries.

- Two-channel, 12/48V phantom power supply
- Lightweight, portable design
- Ultra-quiet operation

#ARADPP  
**\$60<sup>00</sup>**

**ROLLS****PB224**

The PB224 is a 2-channel portable 48V phantom power supply with XLR I/O connectors, powered by dual 9V batteries or an optional AC power supply.

- Portable battery-operated 2-channel 48V power supply
- Power-on LED
- Clean output, molded plastic battery compartment



#ROPB224  
**\$84<sup>95</sup>**

**ART****PHANTOM III****Single-Channel Phantom Power Supply**

The PHANTOM III is a single-channel phantom power supply with XLR connectors.

- Single-channel, 48V phantom power supply
- Lightweight, portable design
- Ultra-quiet operation



#ARPPS  
**\$50<sup>00</sup>**

**WHIRLWIND****Micpower**

The Micpower allows you to use high quality electret-condenser microphones in direct-to-recorder applications or with mixers lacking phantom power.

- Portable source of 12-18V phantom power
- Features a "Battery OK" LED
- (2) 9V batteries provide about 50 hours of continuous use



#WHMICP1  
**\$98<sup>95</sup>**

**EBTECH****Hum X**

The Hum X filters out unwanted voltage and current in the ground line that cause ground loop hum while simultaneously maintaining a solid, safe ground.

- Works with any 15amp outlet
- Removes ground hum
- Maintains safe ground

#EBHX  
**\$59<sup>95</sup>**

**RADIO DESIGN LABS****AV-HK1X**

The AV-HK1X is a mono transformer isolation module for use with a balanced, low-impedance source and either a low or high impedance load. It breaks noise-producing ground loops.

- Provides isolation in balanced lines
- Ground loop elimination
- XLR input and (1) XLR output

#RAAVHK1X  
**\$100<sup>56</sup>**

**EBTECH****HE-8****8-Channel Hum Eliminator/Line Level Shifter**#EBHE8  
**\$219<sup>95</sup>**

The HE-8 is a rack-mount unit that eliminates 60-cycle hum caused by ground loops, and converts unbalanced lines to true balanced lines.

- (8) 1/4" TRS inputs and outputs
- Eliminates AC hum/60Hz buzz and noise quickly and easily
- Completely passive design
- Converts back and forth between balanced and unbalanced lines

**PRO CO****IT-4**#PRIT4A  
**\$299<sup>95</sup>**

The IT-4 provides 4 high-quality line level output transformers for applications that require a superior degree of electrical isolation.



- XLR and 1/4" phone connectors
- (4) channels in a single rack space
- All connectors accessible from front

**PRO CO****IT-1**#PRIT1  
**\$139<sup>95</sup>**

The IT-1 isolation transformer minimizes interference from lighting dimmers, radio transmitters, and 60Hz AC power wiring.

- True floating transformer isolation
- Can be used as a line level direct box
- Ideal for portable and permanent sound systems

**RADIO DESIGN LABS****AV-HK1**#RDLAVHK1  
**\$91<sup>33</sup>**

The AV-HK1 is a stereo transformer isolation module for use with unbalanced, high-impedance audio inputs. Its use eliminates noise-producing ground loops.

- Provides isolation in unbalanced lines
- Ground loop elimination
- (2) RCA inputs and (2) RCA outputs

**HOSA****HEM-331**#HOHEM331  
**\$91<sup>95</sup>**

The HEM-331 Hum Eliminator is designed to get rid of ground loop problems, such as AC hum or buzz and/or pop noise in any audio system.

- Balanced to unbalanced conversion
- (2) ground lift switches
- (2) TRS phone inputs and (2) TRS phone outputs

**EBTECH****HE-2**#EBHE2  
**\$59<sup>99</sup>****2-Channel Hum Eliminator/Line Level Shifter**

The HE-2 eliminates 60-cycle hum caused by ground loops, and converts unbalanced lines to true balanced lines.

- Stereo 1/4" TRS I/O (includes 4 RCA adapters)
- Eliminates AC hum/60Hz buzz and noise quickly and easily
- Completely passive design
- Converts back and forth between balanced and unbalanced lines

**WHIRLWIND****ISO-8**#WHIS08  
**\$399<sup>95</sup>**

The ISO-8 provides 8 channels of XLR line isolation when a ground lift is just not enough to minimize hum and buzz in your system.

- Balancing and isolation with XLR connectors
- Flat frequency response
- Additional ground lift per channel

**WHIRLWIND****ISO-8Q**#WHIS08Q  
**\$399<sup>95</sup>**

The ISO-8Q is the perfect 8 channel 1/4" phone hum fighter where different pieces of gear are connected across long lines.

- Balancing and isolation with 1/4" phone connectors
- Quality transformers for low distortion
- Single unit rack space design

## JK AUDIO Pureformer

The Pureformer provides hum and noise reduction for sound cards and audio equipment, and removes ground loops and DC paths that can cause hum and signal breakup.

- (2) RCA inputs and (2) RCA outputs
- Durable diecast aluminum construction
- High-quality, 600-ohm audio transformers



#JKPUR  
**\$58<sup>95</sup>**

## ROLLS Buzz Off

The HE18 is a two-channel audio hum and buzz remover that will convert an unbalanced signal into a balanced signal, and vice versa.

- Eliminates ground loop hum and buzz
- Leaves signal grounds connected
- Passive; the unit requires no power.



#ROHE18  
**\$64<sup>95</sup>**

## BEHRINGER MicroHD HD400



The HD400 is a two-channel unit that removes AC hum and noise by safely removing noise-producing ground loops.

- (2) 1/4" TRS phone inputs and (2) 1/4" TRS phone outputs
- Converts between balanced and unbalanced signals
- No inherent signal loss

#BEHD400  
**\$19<sup>99</sup>**

## SAMSON S-Convert



S-Convert is a problem solver for interfacing and level matching consumer and professional audio equipment.

- (2) XLR and (2) RCA inputs with (2) XLR and (2) RCA outputs
- Level control for XLR and RCA inputs
- 18V AC adapter included

#SASCONVERT  
**\$49<sup>00</sup>**

## PRO CO AV-1A

The AV-1A allows the line- or speaker-level outputs of AV equipment to be connected to the microphone inputs of house or portable P.A. systems.

- Better sound from projectors, phonographs and recorders
- Ideal for meetings, lectures, and presentations
- 16-ohm dummy load prevents amplifier damage



#PRAV1A  
**\$123<sup>50</sup>**

## RANE BB22

The BB 22 Balance Buddy converts unbalanced -10dBV consumer level RCA outputs up to balanced +4dBu professional XLR inputs.

- (2) XLR male output and (2) RCA input connectors
- Balanced output allows for longer cable runs
- Adds no additional noise



#RABB22  
**\$149<sup>00</sup>**

## ROLLS DB25

The DB25 is a transformer-balanced, passive direct box that features a Ground Lift switch for hum elimination.



- Selectable 0dB, 20dB or 40dB pad
- (2) 1/4" paralleled inputs (1) XLR output
- Recessed switches

#RODB25  
**\$26<sup>95</sup>**

## ROLLS MB15

The MB15 ProMatch converts consumer level stereo RCA signals to balanced XLR professional line level, and back.



- (2) XLR and (2) RCA inputs
- (2) XLR and (2) RCA outputs
- Each side has stereo level controls

#ROMB15  
**\$59<sup>95</sup>**

## APHEX 228

#AP228  
**\$379<sup>00</sup>**



The 228 is an 8-channel unidirectional level matching interface that connects the output of consumer equipment to the input of professional gear.

- (8) discrete -10dBV RCA inputs
- (8) discrete +4dBu XLR outputs
- Extended Range VU meter

## ART T8

#ART8  
**\$149<sup>00</sup>**



The T8 is a totally passive audio interface that uses 8 transformers to separate input and output signal grounds, thereby isolating two systems and reducing hum and ground-loop noise.

- (8) XLR, 1/4" Phone and RCA inputs and outputs
- Reversible mounting ears
- May also be used as a signal splitter

## WHIRLWIND LM2B

#WHLM2B  
**\$148<sup>50</sup>**



This handy little box can be used to match consumer-grade audio devices (-10dB) to pro equipment (+4dB).

- (2) RCA and (1) 1/8" mini input
- (2) XLR balanced outputs
- Individual left and right level controls
- Included power supply

## WHIRLWIND LM2U

#WHLM2U  
**\$122<sup>95</sup>**



This unit matches the level and provides the conversion from balanced professional-grade devices (+4) to unbalanced devices (-10).

- (2) XLR balanced inputs
- (2) RCA and (1) 1/8" mini output
- Individual left and right level controls
- Included power supply

## RADIAL X-Amp

#RAXA  
**\$199<sup>99</sup>**

The Radial X-Amp is an active re-amping device that allows a pre-recorded track from a line level device to drive two guitar amplifiers or effect pedals simultaneously.

- Allows creative manipulation of recorded guitar track
- Two amps may be driven simultaneously
- LED peak indicator and level control



## RADIAL JD7

#RAJD7I  
**\$1099<sup>99</sup>**

The Radial JD7 Injector is a guitar signal distribution amplifier that allows a guitar signal to drive as many as seven amplifiers simultaneously without loss or coloration.

- Jensen transformers eliminate 60-cycle hum
- May be used as a direct box • 1/4" inputs and outputs provided
- Balanced inputs accept prerecorded signals from mixer



## RADIO DESIGN LABS AV-DC4

#RDAVDC4  
**\$223<sup>25</sup>**

The AV-DC4 is a mono transformer-coupled audio divider/combiner module for use with balanced, low- or high-impedance audio inputs and outputs.

- (4) XLR inputs and (4) XLR outputs
- Mono input can feed up to (3) outputs
- Stereo sources can be combined to mono



## WHIRLWIND Split 6

#WHSPLIT6  
**\$76<sup>50</sup>**



The Split 6 provides a well-built solution for splitting a line level signal up to 6 times for feeding multiple destinations.

- XLR female input wired to (6) XLR male outputs
- Feed multiple powered speakers or split intercom lines
- Microphone level safely split by 2

**PRO-CO****MC-2****2-to-1 Microphone Combiner**

The MC-2 is designed for combining the signals from 2 XLR microphones to 1 XLR mixer input.

- Polarity reverse switch on second input
- Uses Pro Co MBT-2 transformer
- Rugged Uni-box construction



#PRMC2  
**\$124<sup>95</sup>**

**WHIRLWIND****IMP Combiner****2-to-1 Microphone Combiner**

The Whirlwind Microphone Combiner is a 2-input, 1-output XLR signal combiner.

- (2) XLR inputs and (1) XLR output
- Phase reverse switch flips the polarity of Input #2



#WHIMCOM  
**\$94<sup>50</sup>**

**WHIRLWIND****IMP Line Level Combiner****2-to-1 Line Level Combiner**

This unit combines two line level signals into one output, and compensates for the 6dB of gain that occurs when two in-phase signals are combined.

- (2) XLR inputs and (1) XLR output
- Ground lift switch

#WHIMCOML  
**\$107<sup>50</sup>**

**WHIRLWIND****SP1x2****1x2 Microphone splitter**

The SP1x2 provides one direct and one transformer-isolated output, from a microphone level input.

- (1) XLR inputs and (2) XLR outputs
- The transformer isolated output features a ground lift switch

#WHSP1X2  
**\$86<sup>95</sup>**

**WHIRLWIND****SP1x3****1x3 Microphone Splitter**

The SP1x3 provides one direct and two transformer-isolated outputs, from a microphone level input.

- (1) XLR inputs and (3) XLR output
- The transformer-isolated outputs feature a ground lift switch.



#WHSP1X3  
**\$99<sup>95</sup>**

**WHIRLWIND****MLTSP1x2****Multisplitter**

The MLTSP1x2 provides four channels of passive and isolated microphone splitting in a single space rack panel.

- (4) XLR inputs and (8) XLR outputs
- One direct and one transformer-isolated output per channel
- Each isolated output has a front panel ground lift switch.

#WHMLTSP1X2  
**\$317<sup>95</sup>**

**PRO-CO****MS-2****1-to-2 Microphone Splitter**

The MS-2 is designed for splitting the signal from a Low-Z balanced microphone between two mixers.

- (1) XLR input and (2) XLR outputs (Direct and Isolated)
- Isolated output has ground lift switch
- Uses Pro Co MBT-1 transformer

#PRMS2  
**\$99<sup>95</sup>**

**PRO-CO****MS-3****1-to-3 Microphone Splitter**

The MS-3 is designed for splitting the signal from a Low-Z balanced microphone between 3 mixers.

- (1) XLR input and (3) XLR outputs (1 Direct and 2 Isolated)
- Isolated outputs have ground lift switches
- Uses Pro Co MBT-1 transformer

#PRMS3  
**\$122<sup>95</sup>**

**ROLLS****Cable Detective CT 1**

Any musician or sound person knows how difficult it is to maintain cables. The CT 1 provides an efficient way to detect shorted or open cables. The unit tests 1/4" TS, 1/4" TRS, RCA, XLR, and MIDI cables plus cross combinations, preparing you for just about any audio situation. Three front-panel LED's make verification a breeze even in dark stage settings.

#ROCT1  
**\$53<sup>95</sup>****WHIRLWIND****Tester**

This versatile cable tester checks many varieties of audio cable. It tests most cable combinations of XLR, 1/4", or RCA Phono plugs for shorts, opens, and polarity reverse. The hands-free design allows manipulation of the cable to locate intermittents. An On/Off switch is provided, with an LED to indicate sufficient testing power. The included belt clip and compact durable casing ensure that you will be able to use this box anywhere.

#WHT  
**\$76<sup>50</sup>****BEHRINGER****CT100**

Tests XLR, mono, and TRS phone (1/4", 1/8", TT), RCA and MIDI connectors. It shows which input pin is connected to which output pin. Separate LED's indicate proper shield connection and phantom power presence. The CT100 also offers an

installed cable test mode, continuity check, and test-tone generator. This microprocessor-controlled device was designed to ensure fast, reliable problem location, and the included belt clip adds to its versatility.

#BECT100  
**\$29<sup>99</sup>****EBTECH****Swizz Army Cable Tester**

The Swizz Army Tester checks XLR, 1/4", RCA, 1/8", TT & MIDI cables for continuity and intermittent connections. Also detects opens and shorts for each pin. Other features include a test-tone generator (+4, -10, Mic), phantom power detector, grounded XLR shield detector, and cable wiring display. The display

LED's will also stay lit until reset, allowing you to catch intermittent faults that may have occurred too quickly to notice otherwise.

#EBSWIZZCT  
**\$89<sup>99</sup>****HOSA****CBT-375**

The CBT-375 is a one-button, automatic cable tester that makes verifying the continuity of your RCA, 1/4", 3.5mm, XLR, Speakon, and Banana connections quick and easy. Just plug one end of the cable into the right side of the tester, plug the other end of the cable into the left side and push the red button on top of the unit. The LED readout will give you a clear indication of your cable's status. Its durable construction will allow many hours of heavy use.

#HOCBT375  
**\$103<sup>95</sup>****WHIRLWIND****QBOX**

The Qbox is the all-in-one audio line tester ideal for applications such as live sound, maintenance, and installation work. It includes a microphone, a speaker, a test tone generator, outputs for standard headphones, a 1/4" jack for line-in or a 2k Ohm (telephone) earpiece out. A handy clip attaches the Qbox to your belt or equipment rack.

#WHQB  
**\$189<sup>95</sup>****ART****CableCOP**

The Cable COP provides testing for mic cables and patch cords with 2 or 3 conductors, instrument cables with 2 conductors, basic speaker cables with 2 conductors, and MIDI cables comprised of DIN5 connectors using 2 conductors. LED's on the CableCOP will only illuminate when the connected cable completes a circuit. As a result, you're able to tell immediately which cables need to be repaired. An LED may also fail to illuminate if a 3-conductor cable has been wired out-of-phase.

#ARCT  
**\$45<sup>00</sup>****WHIRLWIND****MCT-7**

This diagnostic cable tester has connectors for analyzing almost any type of cable combination. The convenient rotary switch allows testing of each conductor within the cable and can determine the internal wiring configuration. It tests NL4, 5 pin DIN (MIDI), BNC, XLR, TRS, RCA and 3.5 mm types with handy connector diagrams printed on the front panel to aid problem identification. With an all-metal housing, this unit is made for the rigors of heavy stage and studio use.

#WHMCT7  
**\$119<sup>95</sup>**

**AT8202** Selectable 10, 20, or 30dB attenuator in-line XLR barrel #AUAT8202.....**\$43.50**



**CP8201** Low-to-High Impedance Transformer XLR-F to 1/4"-M barrel #AUCP8201.....**\$19.95**



**A10Q, A20, A30** Pad w/ 10, 20, or 30dB attenuation in-line XLR barrels #PRMAX10, PRMAX20, PRMAX30 .....**\$34.95**



**FPSC0010B** Mic to Line Level in-line XLR barrel #PRLMX .....**\$34.95**



**FPSC0010B** Ground Lift in-line XLR barrel #PSAGL .....**\$27.55**



**FPSC0010D** Line to Mic Level Pad in-line XLR barrel #PSALMP .....**\$27.55**



**FPSC0010C** Phase Reversal in-line XLR barrel #PSAPR .....**\$27.55**



**A15LA** Line Output to Low Impedance Mic Input in-line XLR barrel #SHA15LA.....**\$34.95**



**9144PC** Low-to-High Impedance Transformer (150-15K Ohms), XLR-F to 1/4"-M barrel #PR9144PC .....**\$56.95**



**ITX** Isolation Transformer (for 600-Ohm Loads) in-line XLR barrel #PRITXMXF.....**\$57.50**



**PRX** Polarity Reverse in-line XLR barrel #PRPRX.....**\$32.95**



**GLX** Ground Lift in-line XLR barrel #PRGLX .....**\$32.95**



**A15PRS** Bi-Directional Polarity switch in-line XLR barrel #SHA15PRS.....**\$54.95**



**A15BT** Bridging Transformer matches balanced and unbalanced levels XLR barrel #SHA15BT.....**\$39.95**



**LTLIMP** Impedance Transformer in-line XLR-F to 1/4"-M barrel #VWHLTIMP.....**\$18.50**



**IMPHR** Phase Reverse in-line XLR Barrel #WHIMPHR.....**\$25.95**



**A15AS** Selectable 15, 20 or 30dB attenuator in-line XLR barrel #SHA15AS .....**\$38.50**



**A95U** Reversible Line Matching Transformer, XLR Male to 1/4" Phone Female #SHA95U .....**\$32.50**



**A85F** Low-to-High Impedance Mic Matching Transformer, XLR-F to 1/4"-M barrel #SHA85F .....**\$17.50**



**A95UF** Line Matching Transformer (for 75-300-Ohm Mics) XLR- F to 1/4"- F barrel #SHA95UF .....**\$34.95**



**MIT-156** Low-to-High Impedance Transformer In-Line XLR-F to 1/8" stereo mini-M, 18" #HOMIT156.....**\$19.95**



**CYX402** Stereo 1/8" Mini Male to 2 XLR Male, 6 ft. #HOYCSMM2XM6 .....**\$14.95**



**XLRJ2XLRP** XLR Female to 2 XLR Male Y-Cable, 18" #COYCXF2XM .....**\$22.99**



**XLRP2XLRJ** XLR Male to 2 XLR Female Y-Cable-18" #COYXM2XF.....**\$22.99**



**YPP308** Stereo 1/4" Female to 2 Stereo 1/4" Male-6" #HOYCSPF2SPM.....**\$5.95**



**YPR257** Stereo 1/4" Female to 2 RCA Male, 6" #HOYCSPF2RM .....**\$5.50**



**SPPS2PJC** Stereo 1/4" Male to 2 RCA Female, 6" #COYCSPM2RF.....**\$3.95**



**YMP137** Stereo 1/8" Mini Male to 2 Mono 1/4" Female, 6" #HOYCSMM2PF.....**\$5.50**



**YPP118** Stereo 1/4" Male to 2 Stereo 1/4" Female-6" #HOYCSPM2SPF6.....**\$5.50**



**YPP136** Stereo 1/4" Female to 2 Mono 1/4" Male, 6" #HOYCSPF2PM .....**\$5.50**



**BNP116** Mono 1/4" to dual Banana, 6", (16 gauge) #HOAPF2B16.....**\$17.95**



**GSK116** Mono 1/4" to Speakon, 6", (16 gauge) #HOAPFS16.....**\$15.95**



**GPR104** 1/4" TS Phone Female to RCA Male  
#HOAPFRM ..... **\$2.95** 

**SPPJ Mono** 1/4" Phone Male to RCA Phono  
Female #COAPMRF..... **\$2.09** 

**GPP273** Stereo 1/4" Phone Male to Angled  
Stereo 1/4" Phone Female  
#HOASPMRASPF ..... **\$7.50** 

**GPR123** Mono 1/4" Phone Male to Angled  
RCA Phono Female (pack of 2)  
#HOAPMRARF2 ..... **\$4.95** 

**GPM103** Stereo 1/8" Mini Female to Stereo  
1/4" Phone Male #HOASMFSPM..... **\$2.95** 

**GPP359** (1) Stereo 1/4" Male Phone to  
(2) Stereo 1/4" Female Phone  
#HOASPM2SPF ..... **\$3.95** 

**GMP112** Stereo 1/8" Mini Male to Stereo  
1/4" Phone Female #HOASMMSPF..... **\$2.95** 

**GPP290** Mono 1/4" Phone Male to Stereo  
1/4" Phone Female #HOAPMSPF..... **\$3.50** 

**SPPMJ** Mono 1/8" Mini Female to Mono  
1/4" Phone Male #COAMFPM..... **\$1.29** 

**GPP105** Stereo 1/4" Phone Female to Stereo  
1/4" Phone Female #HOASPFSPF ..... **\$3.50** 

**SPPXLRJ** Mono 1/4" Phone Male to XLR  
Female Unbalanced #COAPMXF ..... **\$6.99** 

**SPPXLRP** Mono 1/4" Phone Male to XLR  
Male Unbalanced #COAPMXM ..... **\$6.99** 

**GXJ183** Stereo 1/4" Phone Female to XLR  
Female Balanced #HOASPFXF..... **\$12.50** 

**XLRPSPJ** Stereo 1/4" Phone Female to XLR  
Male Balanced #COAPFXM..... **\$6.99** 

**GXP143** Stereo 1/4" Phone Male to XLR Female  
Balanced #HOASPMXF ..... **\$11.95** 

**GXJ235** Stereo 1/4" Phone Female to XLR  
Male Balanced #HOASPFXM ..... **\$9.95** 

**XLRPPJ** RCA Phono Female to  
XLR Male Unbalanced #COARFXM ..... **\$6.99** 

**XLRJPJ** RCA Phono Female to  
XLR Female Unbalanced #COARFXF..... **\$6.99** 

**PPXLRP** RCA Phono Male to  
XLR Male Unbalanced #COARMXM ..... **\$6.99** 

**PPXLRJ** RCA Phono Male to  
XLR Female Unbalanced #COARMXF..... **\$8.99** 

**XLRJBL XLR** Female to XLR Female Balanced  
#COAXFXF ..... **\$8.99** 

**XLRPBL** XLR Male to XLR Male Balanced  
#COAXMXM..... **\$6.99** 

**GSK116** Mono 1/4" Phone Female to Speakon 6"  
#HOAPFS16 ..... **\$19.95** 

**NL4MMXBULK** Speakon Female to Speakon Female  
#HOALSFSF ..... **\$9.95** 

**COMPREHENSIVE**  
**Audio Adapter Kit & Storage Case**

This audio adapter kit provides a pair of virtually every audio adapter in current use. The kit includes a sturdy plastic storage case with 10 compartments w/ adjustable dividers.

- |  |                               |  |
|--|-------------------------------|--|
| (2) Mini Female Stereo to Mini Female Stereo | (2) Mini Male to Phone Female | (2) Phono Female Stereo to XLR Male (Balanced) |
| (2) Stereo Mini Female to Stereo Phone Male  | (2) Mini Female to Phone Male | (2) Phone Female to XLR Male                   |
| (2) Phono Male Stereo to XLR Male (Balanced) | (2) Mini Female to RCA Male   | (1) Stereo Mini Male to 2 RCA Male (Y-Cable)   |
| (2) Phone Male to XLR Male                   | (4) Phone Male to RCA Female  | (1) Phono Male Stereo to 2 Phono Stereo Female |
| (2) Mini Female to Mini Female               | (2) Phone Female to RCA Male  |  |
| (2) RCA Male to XLR Female                   | (2) Phone Male to XLR Female  |  |
| (2) Mini Male to RCA Female                  | (2) XLR Female to XLR Female  |  |
| (4) Phone Female to Phone Female             | (2) RCA Female to XLR Male    |  |

#COAK  
**\$149<sup>95</sup>**



## SABRA SPK Kit

The Sabra-Som SPK is a complete shock mount and pop filter system including: the SPF pop filter, SSM-1 shock mount, and ST2 dual thread support. The SPF pop filter system is effective at eliminating noise caused by plosives, and the SSM-1 shock mount minimizes vibration-related noise.

#SASPK  
**\$109<sup>95</sup>**



## SABRA SPF Kit

The SPF system features two parallel pop filter rings mounted on an articulated arm for easy, sturdy positioning and placement. This flexible pop filter system is highly effective at eliminating breath noise and plosive sounds.

#SASPF  
**\$59<sup>95</sup>**



#POVAC6C  
**\$59<sup>95</sup>**



## POPLESS VOICE SCREENS

### VAC-6

The Popless Voice Screens VAC-6 is a pop filter/gooseneck combination with dual 6" windscreens for enhanced wind diffusion and pop suppression. It features a 15" gooseneck, and the position of each windscreen can be freely adjusted.

#POVACS 6  
**\$59<sup>95</sup>**



## POPLESS VOICE SCREENS

### VAC-s6

The VAC-s6 is a studio pop filter equipped with: a shock mount clamp, an adjustable 8" mini-gooseneck w/ screen holder, and (2) 6"-diameter screens. The VAC-s6 attaches to any microphone shock mount and its positioning is easily adjustable.

## POPLESS VOICE SCREENS

### VAC-RE20

The Popless Voice Screens VAC-RE20 is a pop filter designed for the Electro-Voice RE20 & RE27 broadcast microphones. It attaches to the Electro-Voice 309/A shock mount (required) and features a ball-and-socket joint for easy positioning.

#POVACRE20  
**\$44<sup>95</sup>**



## RAXXESS POMT

The POMT is a 6" STOP-IT pop filter with a flexible gooseneck and a steel stand clamp. The gooseneck allows for proper placement in front of microphones, and the steel clamp attaches easily to any microphone stand. The POMT is very effective at reducing plosives and breath noise in vocal performances.

#RAPOMT  
**\$24<sup>95</sup>**

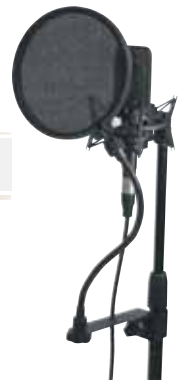

#SHPS6  
**\$29<sup>95</sup>**



## SHURE PS-6

The Shure PS-6 "Popper Stopper" is a pop filter/gooseneck combination that helps reduce noise due to plosive "p" and "b" sounds. It features a 6", 4-layer screen, and includes an adjustable metal gooseneck and a heavy-duty microphone stand clamp.

#SEPS  
**\$39<sup>00</sup>**



## SE ELECTRONICS Studio Pop Screen

The Studio Pop Screen's unique 5 1/4" metal screen is louvered at a slight angle to redirect ultra-low frequency breath blasts, and includes a flexible gooseneck arm and an adjustable stand clamp. The filter does not attenuate high frequencies (as fabric screens do), leaving vocal performances unaffected while reducing annoying low frequency "pops."

**WindTech Series 300** (black) 1 3/8" inside diameter, 1 7/8" depth, 25 colors #WI300.....**\$4.95**

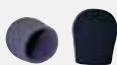

**WindTech Series 900** (black) 1 5/8" inside diameter, 2 1/8" depth, 22 colors #WI900.....**\$4.95**



**WindTech Series 600** (black) 1" inside diameter, 1 3/4" depth, 22 colors #WI600.....**\$4.50**



**WindTech Series 5700** (black) 1" inside diameter, 1 3/4" depth, 22 colors #WI5700.....**\$4.50**



**WindTech Series 1100** (black) 1/4" inside diameter, 3/4" depth, 22 colors #WI1100.....**\$3.95**



**WindTech Series 2300** (black) 3/16" inside diameter, Black or Off-white #WI2300.....**\$3.50**



**Tram BWS** windscreen for TR50 lavalier mic #TRBWS.....**\$12.49**



**Countryman E6 Windscreen** (beige) windscreen for E6 earset mic #COE6WSBE.....**\$5.95**



**Sony WS44** windscreen for ECM-44B lavalier mic #SOWS44.....**\$11.95**



**Sony WSU77S** foam windscreen for ECM-77 lavalier mic #SOWSU77S.....**\$9.99**



**Sony WSM77S** for ECM-77 lavalier #SOWSM77S.....**\$19.95**



**Sony ADR77B** metal windscreen (6 pack) #SOADR77B.....**\$94.95**



**Sennheiser MZW-66P** (black) velour-coated foam windscreen for ME-66 #SEMZW66P.....**\$64.95**



**WindTech BG-1** (black) 3/4" inside diameter, 7 1/4" depth #WIBG1.....**\$27.95**



**WindTech BG-2** (black) 3/4" inside diameter, 11 1/2" depth #WIBG2.....**\$33.50**



**WindTech BG-3** (black) 3/4" inside diameter, 20" depth #WIBG3.....**\$54.50**



**WindTech Series 1200** (black) 3/4" inside diameter, 1 5/8" depth, 22 colors #WI1200.....**\$4.50**



**WindTech Series 1300** (black) 5/8" inside diameter, 1 1/4" depth, 22 colors #WI1300.....**\$3.95**



**WindTech Series 1500** (black) 3/8" inside diameter, 3/4" depth, 22 colors #WI1500.....**\$3.95**



**WindTech Series 500** (black) 1/2" inside diameter, 1 1/4" depth, 22 colors #WI500.....**\$3.95**



**Rycote WindJammer** (black) furry windscreen for lavalier mics, also available: tan, gray, white #RYWFLB.....**\$25.00**



**Remote Audio MicroCat** (black) high-wind universal lavalier windscreen, also available: tan, gray, white #REMCATB.....**\$25.00**



**Audio Technica AT8116** for MT803 & MT831 lavalier mics #AUAT8116.....**\$9.50**



**Lectrosonics RK150** windscreen for M150 lavalier mic #LERK150.....**\$2.98**



**Sennheiser MZW-2F** foam windscreen for ME2 lavalier mic #SEMZW2F.....**\$5.00**



**Sennheiser MZW-2EW** metal windscreen for ME2 lavalier mic #SEMZW2EW.....**\$12.50**



**Shure A58WS** (black) foam windscreen for ball-type mics #SHA58WSBK.....**\$7.50**



**Shure A2WS** (black) locking foam windscreen for SM57 and 545 mics #SHA2WSBK.....**\$22.50**



**WindTech BG-60** (black) 1" inside diameter, 6" depth #WIBG60.....**\$27.95**



**WindTech BG-70** (black) 1" inside diameter, 11 1/4" depth #WIBG70.....**\$33.50**



**WindTech SG-1** (black) 3/4" inside diameter, 11 1/4" depth #WISG1.....**\$27.50**



**WindTech SG-2** (black) 3/4" inside diameter, 11 1/4" depth #WISG2.....**\$34.95**



**ON-STAGE****MY-251**#ONMY251  
**\$2<sup>95</sup>**

The MY-251 is a unique, elliptical-shaped clip designed to fit most brand name microphones. It has a 5/8"-27 female threaded brass insert and a black-finish base.

**WINDTECH  
MC4**#WINC4  
**\$5<sup>50</sup>**

The WindTech MC4 is an extra-large, heavy-duty wireless mic clip that holds most mics up to 1.75" in diameter, threading is brass inserted US standard 5/8"-27.

**ON-STAGE****MY-200**#ONMY200  
**\$4<sup>95</sup>**

The MY-200 is a spring-loaded clip designed to accommodate a variety of microphone sizes. It has a 5/8"-27 female threaded insert in a black-finish plastic base.

**ON-STAGE  
MY-250**#ONMY250  
**\$2<sup>95</sup>**

The MY-250 is an unbreakable rubber mic clip designed for tapered-styled dynamic microphones. It has a 5/8"-27 female threaded insert in a black-finish plastic base.

**ON-STAGE****MY-110**#ONMY110  
**\$4<sup>95</sup>**

The MY-110 is an unbreakable rubber mic clip designed for straight-style handheld wireless microphones. It has a 5/8"-27 female threaded insert in a black-finish plastic base.

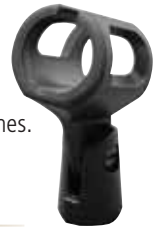
**ON-STAGE  
MY-100**#ONMY100  
**\$4<sup>95</sup>**

The MY-100 is an unbreakable rubber mic clip designed for tapered-styled dynamic microphones. It has a 5/8"-27 female threaded insert in a black-finish plastic base.

**ON-STAGE****MY-200**#ONMY200  
**\$4<sup>95</sup>**

The MY-200 is a spring-loaded clip designed to accommodate a variety of microphone sizes. It has a 5/8"-27 female threaded insert in a black-finish plastic base.

**ON-STAGE  
MY-250**#ONMY250  
**\$2<sup>95</sup>**

The MY-250 is an unbreakable rubber mic clip designed for tapered-styled dynamic microphones. It has a 5/8"-27 female threaded insert in a black-finish plastic base.

**SHURE****A53M**#SHA53M  
**\$37<sup>50</sup>**

The Shure Shock Stopper isolation mount/swivel adapter reduces transmission of mechanical noise and vibration.

**SHURE  
A55HM**#SHA55HM  
**\$34<sup>95</sup>**

Shure's Shock Stopper swivel adapter/isolation mount reduces transmission of noise and vibration, featuring a unique design allowing the mic to be snapped in and out without removing the cable.

**WINDTECH****PG-95**#WIPG95  
**\$6<sup>95</sup>**

The PG-95 is a pistol-grip shotgun microphone clip with a compact, lightweight design. It provides a female 5/8"-27 thread brass insert, and the mic clip angle is adjustable.

**ON-STAGE  
MY-325**#ONMY325  
**\$7<sup>95</sup>**

The MY-325 is a shock-mount mic clip designed to reduce the effects of low-end rumble. It has a 25mm opening for handheld dynamic microphones and a 5/8"-27 female threaded insert.

**ON-STAGE****MY-330**#ONMY330  
**\$7<sup>95</sup>**

The MY-330 is a shock-mount mic clip designed to reduce the effects of low end rumble. It has a 30mm opening for handheld wireless microphones and a 5/8"-27 female threaded insert.

**ON-STAGE  
MY-320**#ONMY320  
**\$7<sup>95</sup>**

The MY-320 is a shock-mount mic clip designed to reduce the effects of low end rumble. It has a 20mm opening for handheld condenser microphones and a 5/8"-27 female threaded insert.

**MIC-EZE****PIG-E-BAK**#MIPB  
**\$34<sup>95</sup>**

The MIC-EZE PIG-E-BAK double mic clamp mounts mics for dual feed and adjusts for phase cancellation. Dual vertical in-line clamp set with a swing type center attachment.

**Min-Eze**#MIMINEZE  
**\$36<sup>95</sup>**

The Min-Eze is an adjustable, dual perpendicular microphone clamp/clip with a trapeze-style center attachment. It features spring-action clamps with extra wide-opening jaws and protective clamp pads.

**ON-STAGE****MY-410**#ONMY410  
**\$23<sup>95</sup>**

The MY-410 is a universal shock mount designed to fit most large condenser microphones (42-48mm). Its die-cast steel adapter is fitted with female 5/8"-27 threads.

**MIC-EZE  
FE5**#MIFES  
**\$36<sup>95</sup>**

The FE5 is an adjustable microphone clamp featuring a 5" gooseneck with spring-loaded, lockable mounting clamps on each end. The clamps open to 2" wide.

**ATLAS  
TM-1**

#ATTM1  
**\$17<sup>50</sup>**

Twin microphone mounts provide for the horizontal attachment of two or three mics onto most stands, goosenecks, and stand adapters.



**ON-STAGE  
MY-500**

#ONMY500  
**\$10<sup>95</sup>**

The MY-500 is a 6" mic extension bar with a 5/8"-27 threaded knob for mounting standard mic clips, and an attachment bracket with tightening knob, to attach to a mic stand.



**K&M  
23500B**

#KM23500B  
**\$27<sup>50</sup>**

K&M fixed microphone support bar measures 8" across and accommodates 2 or 3 microphones.



**ON-STAGE  
MY-700**

#ONMY700  
**\$23<sup>95</sup>**

The MY-700 is a multi-use stereo bar designed to hold up to 6 microphones on 5/8"-27 threaded knobs. Its outside arms can be angled from 0 to 45 degrees.



**ON-STAGE  
MY-550**

#ONMY550  
**\$9<sup>95</sup>**

The MY-550 is a 6" mic extension bar with a 5/8"-27 threaded knob for mounting standard mic clips, and an attachment bracket with tightening knob, to attach to a mic stand.



**WINDTECH  
MPC-10**

#WIMPC10  
**\$14<sup>95</sup>**

The WindTech MPC-10 "C" type, multi-position clamp, fits 1.25" diameter tube or flat surface. The male 5/8"-27 thread insert rotates 90 degrees in three positions. Soft rubber insert prevents scratching.



**WINDTECH  
MA12**

The MA12 is ideal for mounting mics to instruments, drums, brass and hard to reach areas and adapts to standard microphone holders.

#WIMA12  
**\$9<sup>95</sup>**

**ATLAS  
CO1B**

#ATCO1B  
**\$18<sup>50</sup>**

The Atlas CO1B connect-on swivel adapter/clamp facilitates installation of a second mic to any floor or desk stand with 5/8" or 7/8" diameter tubing.



**ON-STAGE  
DM-01**

#ONDM01  
**\$5<sup>95</sup>**

The DM-01 is a clamp designed to securely attach a mic clip to a drum rim. It works with any 5/8"-27 mic clip (black finish).



**ON-STAGE  
DM-50**

#ONDM50  
**\$11<sup>95</sup>**

The DM-50 is a drum rim mic clip that dampens unwanted vibrations when miking drums. It fits 6"-18" drums with rims as tall as 1 3/8" (black powder-coat finish).



**WINDTECH  
DMC-2**

WindTech "C" clamp-style drum clamp, secures microphones to drums and many percussion instruments.

#WIDMC2  
**\$5<sup>50</sup>**

**CAD  
DSM1**

#CADSM1  
**\$19<sup>95</sup>**

The DSM1 is an anti vibration drum microphone mount designed to fit most lug-type drums. It features a quick-release design, rugged die-cast and steel construction.



**ON-STAGE  
TM02C**

#ONTM02C  
**\$3<sup>95</sup>**

The TM02C is a flange mount designed for mounting mic clips to flat surfaces. It has 5/8"-27 female threading, a chrome finish, and it includes mounting screws.



**TM02B** black finish version #ONTM02B ..... **\$3.95**

**ATLAS  
AD12BE**

#ATAD12BE  
**\$8<sup>95</sup>**

The Atlas AD12BE is a surface-mounting flange with a 5/8"-27 threaded fitting to accommodate goosenecks or microphone poles and microphone mounting hardware.



**TM08C**

#ONTM08C  
**\$4<sup>95</sup>**

The TM08C is a flange mount with a rubber base, designed for isolating mic clips from vibration and mounting them to flat surfaces. 5/8"-27 female threading, chrome finish.



**TM08B** black finish version #ONTM08B ..... **\$4.95**

**AUDIO-TECHNICA  
AT8601**

#AUAT8601  
**\$18<sup>95</sup>**

The Audio-Technica AT8601 microphone desk stand is compatible with 5/8"-27 threaded stand clamps.



**AUDIO-TECHNICA**  
**AT8646QM**

The Audio-Technica AT8646QM is an integrated mount, fitted with an XLR Female connector for lectern, pulpit, and conference table microphones.

#AUAT8646QM  
**\$36<sup>95</sup>**



**AUDIO-TECHNICA**  
**AT8416 Mic Shock Mount**

The Audio-Technica AT8416 shock mount effectively isolates mounted microphones from impact vibration and shock handling noise.



#AUAT8416  
**\$49<sup>95</sup>**

**ON-STAGE**  
**DS7100B**

The DS7100B is a non-adjustable, round-based desktop mic stand with a 4" fixed-height shaft and a 6" base. It is a great solution for basic tabletop applications.

#ONDS7100B  
**\$6<sup>49</sup>**



**DS7200B**

The DS7200B is a round-base desktop mic stand that is adjustable in height from 9"-13". This stand features a die-cast steel clutch, a removable shaft, and a 6" base. **DS7200C chrome version #ONDS7200C..... \$11.95**

#ONDS7200B  
**\$11<sup>95</sup>**



**ATLAS**  
**DS-2**

The Atlas DS-2 is a desktop mic stand with a square, vibration-isolating base. The stand measures 4" in height and features a threaded pole that accommodates any standard microphone mount.

#ATDS2  
**\$27<sup>95</sup>**



**ATLAS**  
**DS-5**

The Atlas DS-5 is a fixed-height, desktop mic stand with a round cast-iron base that measures 5" high, accommodating any standard microphone mount.



#ATDS5  
**\$11<sup>95</sup>**

**AKG**  
**ST305**

The ST305 is a cast-iron tabletop microphone stand with a Neoprene-layered shock-mounted base, measuring 6.25" in height, and accommodating all standard microphone mounting hardware.

#AKST305  
**\$207<sup>95</sup>**



**SHURE**  
**S37A**

The Shure S37A low-profile microphone desk stand is designed for use with various Shure swivel adapters and shock mounts, and has a non-reflective, gray-colored finish.

#SHS37A  
**\$26<sup>95</sup>**



**ATLAS**  
**DS-7**

The Atlas DS-7 is a sturdy round-base table stand that is adjustable in height from 8-13 inches and fits all standard mic mounting hardware.

#ATDS7  
**\$16<sup>50</sup>**

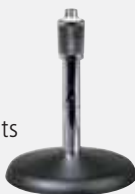

**K&M**  
**23110N**

The K&M 23110N low-profile tabletop microphone stand offers sturdy, folding tripod legs and is compatible with standard microphone mounting hardware.



#KM23110N  
**\$9<sup>95</sup>**

**ON-STAGE**  
**DS300B**

The DS300B is a mini boom desktop stand equipped with the innovative Posi-Lok clutch and a 6" diameter base. The Posi-Lok clutch features 52-locking teeth and an ergonomic knob.

#ONDS300B  
**\$19<sup>95</sup>**



**ON-STAGE**  
**MSA-9500**

Includes: Posi-Lok clutch, 7", 13", 18" boom attachment, 5/8"-5/8" & 5/8"-7/8" connectors for desktop weighted bases.



#ONMSA9500  
**\$28<sup>70</sup>**

**ON-STAGE**  
**QK2-B**

The QK2-B is a quick-release mic adapter that allows you to quickly interchange a mic/mic clip with a touch of a button (black finish).

#ONQK2B  
**\$12<sup>95</sup>**



**ATLAS**  
**LO2B**

The Atlas LO2B is particularly useful for applications that require the quick removal of stand-mounted mics and features a secure, snap-on fastener and durable, push-button release.



#ATLO2B  
**\$16<sup>50</sup>**

**AUDIO-TECHNICA**  
**AT8459**

Audio-Technica 8459 Dual swivels provide an unlimited number of positions for exact mic placement; compatible with 5/8"-27 threaded stands.

#AUAT8459  
**\$39<sup>95</sup>**



**SHURE**  
**A27M**

The Shure A27M is a stereo microphone adapter designed to hold two microphones in selectable positions for stereo broadcasting, recording, or sound reinforcement (ideal for flexible independent positioning).

#SHA27M  
**\$59<sup>95</sup>**



**ATLAS**

**GN Series**

**Flexible Goosenecks**

The Atlas GN-6(E)/GN-13(E)/GN-19(E) are flexible goosenecks in 6", 13", and 19" lengths, respectively, attach to any microphone stand or adapter, and are available in chrome or ebony (E) finishes.

- GN19** #ATGN19.....**\$11.95**
- GN19E** #ATGN19E.....**\$11.95**
- GN13** #ATGN13.....**\$9.50**
- GN13E** #ATGN13E.....**\$9.50**
- GN6** #ATGN6.....**\$5.50**
- GN6E** #ATGN6E.....**\$5.50**



**ON-STAGE**

**MSA9030-06C**

#ONG6C  
**\$2.99**

The MSA9030-06C is a chrome-finish 6" gooseneck with 5/8"-27 male/female threads

**MSA9030-06B** black version #ONG6B.....**\$2.99**



**ON-STAGE**

**MSA9030-13C**

#ONG13C  
**\$4.95**

The MSA9030-06C is a chrome-finish 13" gooseneck with 5/8"-27 male/female threads.

**MSA9030-13B** black version #ONG6B.....**\$3.95**



**ATLAS**

**BE-E**

#ATBEE  
**\$18.50**

The B-EE is a two-section boom arm with an adjustable length of 24"-39", a metal swivel mount with 5/8"-27 threads (black).



**ATLAS**  
**PB21XE**

#ATPB21XE  
**\$43.95**

The PB21XE is an extendable-length boom arm with a fixed 3/4-lb counterweight. Its length is adjustable between 16 1/4"-24 1/2" (black).



**ON-STAGE**

**MSA7040TB**

#ONMSA7040TB  
**\$14.85**

The MSA7040 is a top-mounting, telescoping boom arm adjustable in length between 19"-32" (black).



**ON-STAGE**

**MSA7020B**

#ONMSA7020B  
**\$11.45**

The MSA7020B is a 32" fixed-length, top-mount boom arm (black).



**QUIK-LOK**

**A-113**

#QUA113BK  
**\$32.95**

The A-113 is a 30" fixed-length boom arm with a fast, non-slip boom swivel adjustment and a non-reflective, black enamel finish.



**QUIK-LOK**

**A-291**

#QUA291B  
**\$39.95**

The A-291 is a telescopic boom arm that adjusts from 22" - 40", with a non-slip boom swivel adjustment and a non-reflective, black enamel finish.



**ON-STAGE**

**MSA-9508**

#ONMSA9508  
**\$11.90**

The MSA-9508 is a 7" Posi-Lok mini-boom with a clamp style attachment for floor & desktop stands.



**ON-STAGE**

**MSA-9502**

#ONMSA9502  
**\$8.90**

The MSA-9502 is a Posi-Lok clutch with a 7" mini boom arm, in black finish.

**MSA-9503** 13" version #ONMSA9503.....**\$9.90**



**K&M**

**21110B**

#KM21110B  
**\$29.95**

The 21110B is a telescoping boom arm with counterweight that is adjustable between 18"-30" (black finish).



**K&M**

**21120B**

#KM21120B  
**\$32.95**

The 21120B is an extra-long telescoping boom arm with counterweight that is adjustable between 22"-38" (black finish).



**ON-STAGE**

**MA200**

#ONMA200  
**\$1.95**

The MA200 is a 5/8" male to 3/8" mic screw adapter for use with mic stands with European 3/8" threads.



**ON-STAGE**

**MA100**

#ONMA100  
**\$1.95**

The MA100 is a 3/8" male to 5/8" mic screw adapter for use with mic stands with European 3/8" threads.



**ULTIMATE-SUPPORT**

**MC05**

Round-Base Microphone Stand (black)

#ULMC05B  
**\$27<sup>99</sup>**

The Ultimate Support MC05 microphone stand features a cast-iron round base and an ergonomically-designed clutch for easy height adjustment from 34"-64".



**ULTIMATE-SUPPORT**

**MC-87**

Adjustable Microphone Stand w/Quick-Release Clutch

#ULMC87  
**\$49<sup>99</sup>**

The Ultimate Support MC-87 microphone stand features a quick-release clutch for easy adjustment. The stand is adjustable from 34"-64" and is uniquely designed to allow multiple stands to be stacked and stored effortlessly.



**ULTIMATE-SUPPORT**

**MC-97**

Tripod Microphone Stand w/Boom

#ULMC97  
**\$69<sup>99</sup>**

One-hand clutch and low-profile stackable base allow simple height adjustment and storage of up to six stands. 40"-60" adjustable height.



**ATLAS**  
**MS-10C**

Leader Stand Series Round-Base Microphone Stand

#ATMS10C  
**\$24<sup>95</sup>**

The Atlas MS10C (Chrome) Leader series microphone stand features a round cast-iron base with an adjustable height from 35"-63".

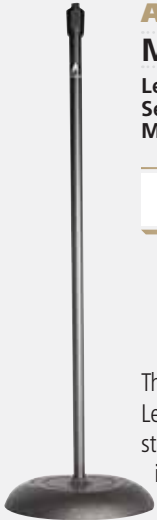

**ATLAS**  
**MS-25**

Heavy-Duty Triangular-Base Microphone Stand

#ATMS25  
**\$119<sup>95</sup>**

The Atlas MS-25 microphone stand features a triangular, cast-iron base for use on stage or broadcast. The stand is adjustable in height from 38"-67".



**ON-STAGE**  
**MS7201B**

Round-Base Microphone Stand

#ONMS7201B  
**\$21<sup>95</sup>**

The MS7201B is a round-base mic stand, adjustable from 34"-60" in height. It features a 9-lb sand-cast base, a steel mid-point locking clutch, and a black powder-coat finish. Base diameter: 10"

**MS7201C** chrome version  
#ONMS7201C..... **\$22.95**

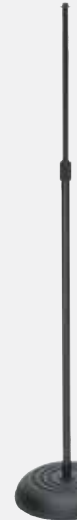

**ON-STAGE**

**MS7600**

Hex-Base Mic Stand

#ONMS7600B  
**\$21<sup>95</sup>**

The MS7600 is a conventional threaded-shaft mic stand with an adjustable height of 34"-60". It features a low-profile design, a uniquely-shaped 9-lb base, and a black finish.



**ON-STAGE**

**MS7625B**

Hex-Base Quarter-Turn Mic Stand

#ONMS7625B  
**\$19<sup>95</sup>**

The MS7625B is a hex-base threadless microphone stand that is easily assembled or disassembled with a quarter-turn clockwise to lock, and a quarter-turn counter-clockwise to remove. It features a low-profile design and a uniquely-shaped 9-lb base.



**ON-STAGE**

**MS7625PG**

Pistol-Grip Hex Mic Stand

#ONMS7625PG  
**\$34<sup>95</sup>**

The MS7625PG is a hex-base threadless microphone stand that is easily assembled or disassembled with a quarter-turn clockwise to lock, and a quarter-turn counter-clockwise to remove. It features a pistol grip on the top of the stand for one-handed height adjustment.



**ON-STAGE**

**MS7700B**

**Euro-Style Tripod Base  
Mic Stand**

#ONMS7700B  
**\$19<sup>95</sup>**

The MS7700B is an extremely stable tripod microphone stand with an adjustable height of 36"-63" and a base spread of 23". It features long foldable legs and a steel mid-point locking clutch.

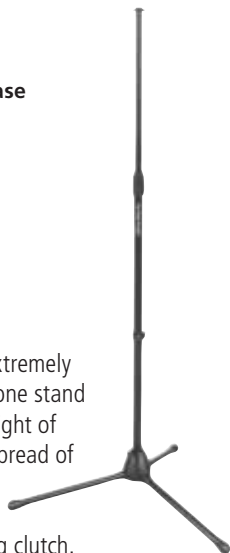

**QUIK-LOK**

**A-300**

**Tripod  
Microphone Stand w/  
Fixed Boom**

#QUA300  
**\$39<sup>95</sup>**

The Quik-Lok A-300 microphone boom stand features a sturdy tripod base with locking legs. The telescoping boom is adjustable in length from 30"-76.2" and the stand height is adjustable from 37.75"-65".



**ATLAS**

**TEB-B**

**Tripod Microphone  
Stand w/Boom**

#ATTEBE  
**\$34<sup>50</sup>**

The Atlas TEB-B a light-weight tripod microphone stand/ boom combo. The stand's height is adjustable from 37"-65", and the boom length between 24"-39" (black).



**K&M**

**21020B**

**Tripod  
Microphone  
Stand w/Boom**

#KM21020B  
**\$74<sup>95</sup>**

The K&M 21020B tripod microphone stand/boom provides lightweight, sturdy support for live sound and recording applications. It has a fixed-length, 32" boom, and its height is adjustable from 35.50"-65".



#ONMS7701B  
**\$28<sup>95</sup>**

**ON-STAGE**

**MS7701B**

**Euro Boom  
Microphone Stand**

The MS7701B is a foldable boom stand with an adjustable height of 36"-63", a boom length of 30" and a base spread of 23". It features a cast-steel mid-point clutch, high impact plastic leg housing, and a removable boom arm.

**MS7701TB adjustable-boom  
version (19"-33")**  
#ONMS7701TB..... **\$36.95**

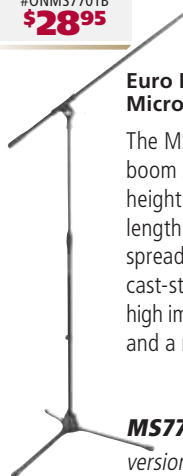

**QUIKLOK**

**A206B**

**Tripod with  
Telescopic Boom**

#QUA206B  
**\$79<sup>95</sup>**

The A206B is a heavy-duty tripod mic stand with an adjustable height of 37.75"-65.25". It features a telescoping boom arm (22"-40"), steel tubing, and high-grade hardware. Base spread: 27.5"

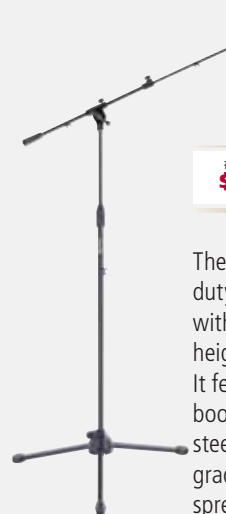

**SHURE**

**S15A**

**Tripod Floor Stand**

#SHS15A  
**\$157<sup>50</sup>**

The S15A is a lightweight tripod floor stand designed for portability. It features 5 telescoping sections with a height adjustable between 3.5 ft. and 14 ft. Carrying case included.



**ON-STAGE**

**SMS7650**

**Hex-Base  
Studio Boom**

#ONSMS7650  
**\$129<sup>95</sup>**

The SMS7650 is a heavy-duty studio boom with a 3-section vertical shaft that is adjustable in height from 38"-80". It features a 22-lb base with removable casters, a 79" boom arm w/counter weight, and a 7" mini-boom adapter.

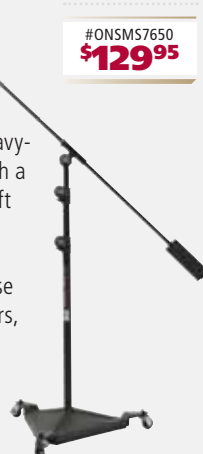

**ON-STAGE**

**SB96+**

**Studio Boom**

#ONSB96P  
**\$103<sup>95</sup>**

The SB96+ is a studio boom stand with a telescoping vertical shaft that is adjustable from 45"-76" in height. It features an extra long telescoping boom (43"-79") with a solid steel counterweight, a 40-tooth boom clutch, and a Posi-Lok mini-boom arm with mic clip.



**ON-STAGE****SS7730****Classic Speaker Stand**#ONSS7730  
**\$44.95**

The SS7730 is a steel/aluminum speaker stand with an adjustable height of 44"-80". It has a 1 3/8" diameter upper shaft (with a 1 1/2" adapter included), a base spread of 32"-48" and a weight capacity of 160 lbs (black).

**ON-STAGE****SS7761B****All-Aluminum Speaker Stand**#ONSS7761B  
**\$44.95**

The SS7761B is an all-aluminum speaker stand with an adjustable height of 44"-80". It has a reversible 1 3/8"-1 1/2" upper shaft (with locking safety pin), folding tripod leg, and a weight capacity of 120 lbs (black).

**ON-STAGE****SS7766****6-Position Speaker Stand**#ONSS7766  
**\$63.49**

The SS7766 Airhead is an aluminum tripod speaker stand equipped with a 6-position push-up locking system, and a pneumatic shock absorber in the center shaft. Its has an adjustable height of 40"-73" and a weight capacity of 100 lbs (black).

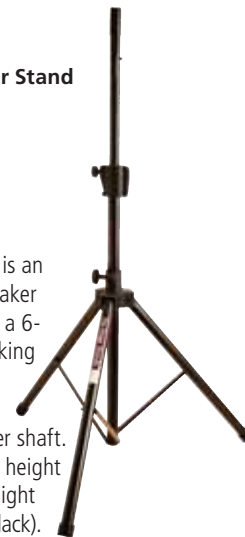
**ON-STAGE****SS8800B+****Power Crank-Up Speaker Stand**#ONSS8800BP  
**\$94.95**

The SS8800B+ is an aluminum tripod speaker stand that can be cranked up by hand or powered up by an electric or cordless drill (drill not included). It has an adjustable height of 47"-80" and a weight capacity of 100 lbs (black).

**ULTIMATE-SUPPORT****TS-80****6'7" Speaker Stand (silver)**#ULTS80S  
**\$79.99**

The TS-80 is a sound reinforcement speaker stand with adjustable height between 3'8" and 6'7". Its load capacity is 150 lbs and it weighs just 6 lbs 4 oz. The base diameter is 47" and it measures just 43.50" x 5.50" when folded.

**ULTIMATE-SUPPORT****TS-90****6'7" Speaker Stand w/Telelock collar (black)**#ULTS90B  
**\$99.99**

The TS-90 is a sound reinforcement speaker stand featuring the unique "TeleLock" collar (that allows one person to set up heavy speakers easily). It has an adjustable height between 3'8" and 6'7" and a load capacity of 150 lbs.

**ULTIMATE-SUPPORT****TS-88B****6'7" Speaker Stand (black)**#ULTS88B  
**\$109.95**

The TS-88B is a light-weight aluminum sound reinforcement speaker stand with an adjustable height between 5'2" and 6'7", and a load capacity of 150 lbs. Measuring 57.5" folded, the stand features a glass-reinforced telescoping collar and a die-cast metal collar clamp for maximum stability.

**ULTIMATE-SUPPORT****TS-99B****9'2" Speaker Stand (black)**#ULTS99B  
**\$129.95**

The TS-99B is a light-weight sound reinforcement speaker stand with an adjustable height from 5'2" to 9'2", and a load capacity of 150 lbs. The stand measures 57.5" folded, and features the "TeleLock" collar, allowing for easy one-person speaker setup.

**ON-STAGE****Mix-400****Autolocator/Mixer Stand**#ONMIX400  
**\$99.95**

The Mix-400 is a rolling stand designed for autolocators, mixers, and drum machines. It features a heavy-duty base with casters, a height-adjustable shaft and a completely adjustable (width & angle) top platform.



**ON-STAGE**

**MS7920B**

Bass Drum/Boom Combo

#ONMS7920B  
**\$19<sup>95</sup>**

The MS7920B is a low-profile, weighted-base boom stand designed specifically for miking kick drums. Its height is adjustable, and it features a 16" boom, a mid-point clutch, and heavy die-cast base.

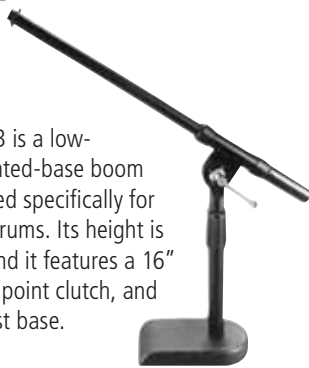

**ON-STAGE**

**MS7411B**

Drum/Amp Tripod w/Boom

#ONMS7411B  
**\$23<sup>75</sup>**

The MS7411B is a low-profile tripod boom stand designed for drum and amp cabinet miking applications. Its height is adjustable, and it features a 16" boom, a mid-point clutch, and folding legs.

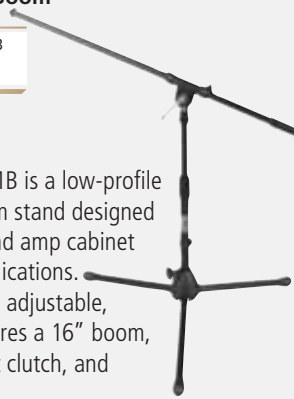

**ON-STAGE**

**MS7311B**

Kick Drum/Amp Stand

#ONMS7311B  
**\$25<sup>75</sup>**

The MS7311B is a weighted-base boom stand designed for miking kick drums and amp cabinets. Its height is adjustable from 8"-14", and it features a 17" boom, a mid-point clutch, and a die-cast base.



**K&M**

**25910B**

Tripod Microphone Stand w/Boom

#KM25910B  
**\$69<sup>95</sup>**

The K&M 25910B is a short tripod microphone stand/boom ideal for kick drum, bass, and guitar cabinet miking. It provides a fixed boom length of 21" and fixed height of 10.50".



**QUIK-LOK**

**BS-313**

Single-Brace, Low-Profile Amp Stand

#QUBS313  
**\$26<sup>95</sup>**

Adjustable, single-brace stand designed for small guitar, bass, keyboard amps, and combos. Height adjustment range: front tier 8.25-11", back tier 11.4-18.6"; depth range 11.8-15"; weight capacity 75 lbs



**QUIK-LOK**

**BS-317**

Double-Brace, Low-Profile Stand

#QUBS317  
**\$47<sup>95</sup>**

Adjustable, all-steel stand perfect for large guitar, bass, keyboard amps, and combos. Height adjustment range: front tier 8.25-11", back tier 11.4-18.6"; depth range 11.8-15"; weight capacity 100 lbs



**QUIK-LOK**

**QL-640**

Fully-Adjustable Amp Stand

#QUQL640  
**\$62<sup>95</sup>**

Full-circle, tilt-adjustable amp platform allows for exact amp positioning. Five height adjustment positions w/spring-loaded locking pin. Height adjustment range: 12.4"-24.8", depth range: 15.5"-23.7", weight capacity: 60 lbs



**ON-STAGE**

**KS7350**

Pro Heavy-Duty Folding-Z Stand

#ONKS7350  
**\$59<sup>95</sup>**

The KS7350 is a versatile keyboard stand with a weight capacity of 500 lbs. It allows for independent height or width adjustments and folds for easy storage. Applications: DJ, mixers and keyboards; height adjustment: 24"-38"



**ON-STAGE**

**KS7365EJ**

Pro Heavy-Duty Folding-Z w/2nd Tier

#ONKS7365EJ  
**\$116<sup>50</sup>**

The KS7365EJ is a heavy-duty, two-tier keyboard stand with a weight capacity of 400 lbs. Its height is adjustable between 28" and 36", and its width adjusts between 20" and 37".

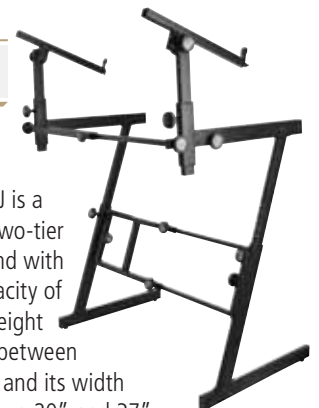

**QUIK-LOK**

**QLX-22**  
Double-brace  
"X" Stand  
w/adjustable  
2nd Tier

#QUQLX22  
**\$97<sup>50</sup>**



The QLX-22 is a double-brace "X" style keyboard stand with adjustable second tier and unique "QLX RECALL" locking disc system. Load capacity: 200 lbs

**ULTIMATE-SUPPORT**

**IQ-1000**  
Single-Brace/Single-Tier  
"X" Stand

#ULIQ1000  
**\$49<sup>99</sup>**

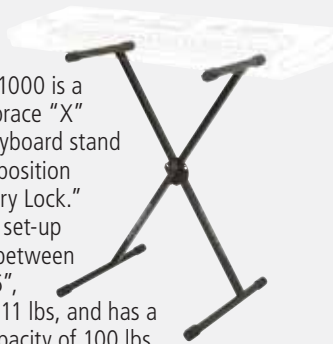

The IQ-1000 is a single-brace "X" style keyboard stand with 4-position "Memory Lock." It has a set-up height between 26.5-36", weighs 11 lbs, and has a load capacity of 100 lbs.

**ULTIMATE-SUPPORT**

**IQ-2000**  
Double-Brace/Single-Tier  
"X" Stand

#ULIQ2000  
**\$69<sup>99</sup>**

The IQ-2000 is a double-brace "X" style keyboard stand with 4-position "Memory Lock." It has a set-up height between 26.5 and 36", weighs 15 lbs, and has a load capacity of 150 lbs.



**ON-STAGE**

**KS8391**

Double-X Stand

#ONKS8391  
**\$29<sup>95</sup>**

The KS8391 is an adjustable height stand with a weight capacity of 200 lbs. It features double-X supports and the patent-pending quikSQUEEZE technology (5-position steel reinforced clutch and center hinge). Height adjustment: 27"-39"; base spread: 11"-30"

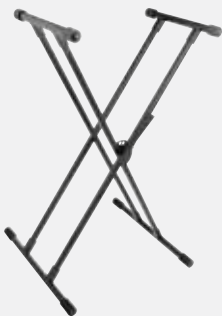

**ON-STAGE**

**KS8290**

Pro Heavy-Duty  
Single-X Stand

#OMKS8290  
**\$46<sup>95</sup>**

The KS8290 is a heavy-duty single-X stand with a weight capacity of 395 lbs. It features On-Stage's heaviest tubing, a 5-position ERGO-LOK clutch and Lok-Tight construction. Applications: large-format keyboards; height adjustment: 27"-39"; base spread: 11"-30"



**ON-STAGE**

**KS8291**

Pro Heavy Duty  
Double-X Stand

#ONKS8291  
**\$54<sup>95</sup>**

The KS8291 is a heavy duty double-X stand with a weight capacity of 395 lbs. It features On-Stage's heaviest tubing, a 5-position ERGO-LOK clutch, and Lok-Tight construction. Applications: large-format keyboards; height adjustment: 27"-39"; base spread: 12"-32"

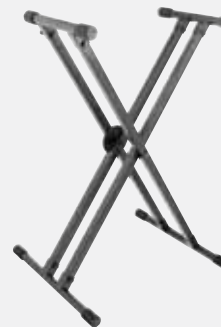

**ON-STAGE**

**KSA7500**

Universal 2nd Tier

#ONKSA7500  
**\$24<sup>95</sup>**



The KSA7500 is universal 2nd tier that includes an internal attachment to fit any keyboard stand with either 1" or 30mm round or square tubing. Weight capacity: 60 lbs

**ULTIMATE SUPPORT**

**VS-80B**

V-Stand

#ULVS80  
**\$179<sup>99</sup>**

The VS-80B is a versatile keyboard, DJ equipment & console stand ideal for live performances requiring quick setup and tear-down. It has a load capacity of 250lbs, fully adjustable height of 24.5" - 41.5" and folds into a compact 28 x 9.5 x 6" (black).



**ULTIMATE SUPPORT**

**Apex AX-48B**

Column Keyboard Stand

#ULA  
**\$189<sup>99</sup>**

The AX-48B is a 46" column keyboard stand designed for live performance. This dual-tier stand has a load capacity of up to 125 lbs. per tier and folds into a self-contained, compact unit with a heavy-duty carrying handle (black).



**AX-48S** matte-silver finish version  
#ULAX48S..... **\$189.99**

**ON-STAGE**  
**SM7122B**

#ONSM7122BB  
**\$13<sup>95</sup>**

The SM7122B is a compact sheet music stand with a two-section telescoping shaft and a cam-lock clutch. It can be used sitting or standing, and the tripod leg assembly folds up for storage (black).

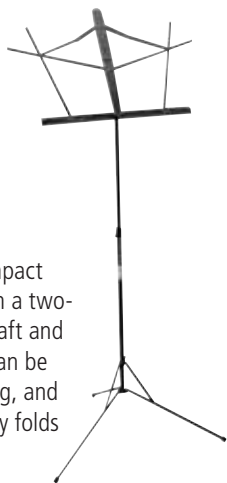

**SM7122N** nickel-finish version  
#ONSM7122NB .....**\$9.95**

**ON-STAGE**  
**SM7611B**

#ONSM7611B  
**\$43<sup>95</sup>**

The SM7611B is a hex-based conductor's stand with an adjustable height of 32"-48" (clutchless). It features a tilting 13 1/2x19" bookplate with a 2" lip and a 12" base.



**ON-STAGE**  
**SM7211B**

#ONSM7211B  
**\$45<sup>95</sup>**

The SM7211B is a tripod-based conductor's stand with an adjustable height of 25"-45". It features a mid-point clutch and a tilting 13 1/2x19" bookplate with a 2" lip.



**ON-STAGE**  
**KT7800**

#ONKT7800  
**\$29<sup>95</sup>**

**3-Position X-Style Bench**



The KT7800 is an affordable bench designed for studio or home use, with a weight capacity of 300 lbs. It features a 2" padded

covered seat and folding legs. Bench seat size: 12x17"; 6 adjustable height positions

**ON-STAGE**  
**KT7800+**

#ONKT7800P  
**\$49<sup>95</sup>**

**Deluxe X-Style Bench**



The KT7800+ is a deluxe keyboard bench designed for comfort, and a weight capacity of 360 lbs. It features a 3" cushioned seat, folding legs, and

a spring-loaded, double-deadbolt locking system. Bench seat size: 12-1/2x23-1/2"; 8 adjustable height positions

**ON-STAGE**  
**KSB6500**

#ONNKS6500  
**\$28<sup>25</sup>**

**Folding Z and Platform Stand Carry Bag**



The KSB6500 is a heavy-duty carry bag designed

for folding Z and platform keyboard stands. It is made of a padded nylon material, and provides 2 hand straps, 2 internal Velcro straps, and a center length-wise double zipper. Dimensions: 30x16x8.75"

**CASIO**  
**PBench**

#CAPBO  
**\$39<sup>95</sup>**



The PBench is capable of holding up to 250 pounds and folds flat for easy portability. The padded black seat cushion makes this portable bench comfortable as

well as attractive; it's the perfect complement to your digital piano or keyboard.

**YAMAHA**  
**PKBB1**

#YAPKBB1  
**\$39<sup>95</sup>**



The PKBB1 offers lasting comfort and a reputation as one of Yamaha's top-selling benches. Its ultra-thick padding and extra-wide single seat assures the utmost comfort for hours of music enjoyment. With a

definitive black finish and a soft padded seat, this bench is fully adjustable for individual comfort, and folds up for your traveling convenience.

**GATOR CASES**  
**GX-33**

#GAGX33  
**\$34<sup>99</sup>**

**Mic Stand Bag**



The GX-33 is a rugged microphone stand bag with 3 separate compartments for mic stands and 5 form-fitted mic drops. It is constructed of 600-denier nylon and provides 2 webbed handles & an adjustable shoulder strap. Dimensions: 55x8.5" diameter

**RAXXESS**

**Elite Speaker Stands**

ERSS-42's are studio monitor stands constructed of fused melamine with a fixed height of 42". They have 14"-square platforms and bases, dual-cable management ducts, and feature contrasting silver trim (pair).



**ESS-42BSL** *ebony finish* #RAESS42BSL.....**\$229.95**  
**ESS-42MSL** *maple finish* #RAESS42MSL.....**\$229.95**

**ON-STAGE**

**SM6000-P**

**Adjustable Studio Monitor Stands**

#ONSM56000P  
**\$84.95**



The SM6000-P is a studio monitor stand with an adjustable height of 36"-52" and a 9"-square top platform. Its 3-point triangular base is equipped with leveling spikes and its weight capacity is 90 lbs (pair).

**RAXXESS**

**Economy Speaker Stands**



ERSS's are studio monitor stands constructed of 3/4" furniture-grade hardboard and finished in a black oak laminate. The speaker platform and base are 12" square (pair).

**ERSS-36 36"** *version*  
 #RAERSS36 ....**\$134.95**  
**ERSS-42 42"** *version*  
 #RAERSS42 ....**\$139.95**

**SAMSON**

**MS-200**

#SAMS200  
**\$69.00**



MS-200's are professional-grade isolated studio monitor stands with a telescoping column (adjustable from 30"-50"), a solid metal speaker platform and heavy base with carpet spikes. 40 lbs maximum speaker load (pair)

**MS-100** #SAMS100 ..... **\$59.00**

**RAXXESS**

**Graphite Group Speaker Stands**

The GRFSS42 is a pair of studio monitor speaker stands made of medium-density fiberboard with a vinyl brushed-aluminum finish. The speakers are 42" in height, feature a 5"-square center post, and measure 14" square at the base, which is equipped with rubber floor bumpers (pair).

#RAGRFSS42  
**\$204.95**



**ULTIMATE SUPPORT**

**MS-45B2**

#ULMS45B2  
**\$188.95**

Aluminum Studio Monitor Stands MS-45B2's are aluminum studio monitor stands with a fixed height of 45" and a 9"-square top plate. They have a triangular metal spiked base, a streamlined cable management system, and a weight capacity of 75 lbs (pair).



**MS-36B2 36"** *version* #ULMS36B2.....**\$174.95**

**QUIKLOK**

**BS-342**

**Heavy-Duty Monitor Stand**

BS-42's are heavy-duty monitor stands with a tri-support design, adjustable leveling floor spikes, and a fixed height of 42". They have 11" rubber padded square top plates, integrated cable management, and a weight capacity of 125 lbs (pair).

#QUBS342  
**\$139.95**

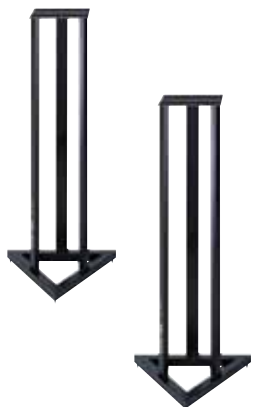

**BS-336 36"** *version* #QUBS336.. **\$129.95**

**MIDDLE ATLANTIC**

**Edit Center Speaker Stands**

Edit Center Speaker Stands are 36" fixed height monitor stands featuring high-mass all wood construction, unique dual cable channels and reversible speaker platforms & bases (graphite or cherry wood). Include both carpet spikes and rubber feet. (pair)

#MIECSPK36  
**\$399.95**



**OMNIMOUNT PRO**  
**WB Series**

WB Series mounts are designed to support enclosures of limited strength as a bottom mount or virtually invisible mount when attached to the top of an enclosure. These mounts provide a wide range of vertical and horizontal movement.

**Wall to bottom/top of the enclosure**  
*Available in black or white*

- WB 20.5** for enclosures up to 20.5 lbs; black #OM205WBB, white #OM205WBW..... **\$39.95**
- WB 30.0** for enclosures up to 30 lbs; black #OM300WBIFKB, white #OM300WBIFKW... **\$76.95**
- WB 60.0** for enclosures up to 60 lbs; black #OM600WBB, white #OM600WBW..... **\$89.95**



- WB 120.0** for enclosures up to 120 lbs; black #OM1200WBB, white #OM1200WBW..... **\$129.50**



**OMNIMOUNT PRO**  
**WBX Series**

WBX mounts are WB mounts that provide a longer reach from the wall. The supporting tube is approximately 25% longer and 25% larger in diameter than the WB. It is used for larger enclosures needing more rotation for proper coverage.

**Wall to bottom/top of the enclosure (extended)**  
*Available in black or white*

- WBX 30.0** for enclosures up to 30 lbs  
black #OM300WBXB, white #OM300WBXW..... **\$69.95**
- WBX 60.0** for enclosures up to 60 lbs  
black #OM600WBXB, white #OM600WBXW ..... **\$88.95**
- WBX 120.0** for enclosures up to 120 lbs  
black #OM1200WBXB, white #OM1200WBXW ... **\$137.50**

**OMNIMOUNT PRO**  
**WA Series**

WA mounts provide a more limited range of vertical and horizontal movement, but have less visual impact on the room environment. For enclosures having footings at the back of the enclosure, the WA is the best mounting solution for the widest coverage.

**Wall to back of the enclosure**  
*Available in black or white*

- WA 20.5** for enclosures up to 20.5 lbs  
black #OM205WAB, white #OM205WAW..... **\$39.95**
- WA 30.0** for enclosures up to 30 lbs  
black #OM300WAIFKB, white #OM300WAIFKW..... **\$69.95**
- WA 60.0** for enclosures up to 60 lbs  
black #OM600WAB, white #OM600WAW ..... **\$89.95**
- WA 120.0** for enclosures up to 120 lbs  
black #OM1200WAB, white #OM1200WAW ..... **\$129.50**



**QUIKLOK**  
**QL-30**  
**Speaker Wall Mount**

The QuikLok QL-30 is a speaker wall mount with a 2-hole speaker plate, a 4-hole wall plate, and a front-to-back depth of 4.75"; an ideal mounting solution for all types of commercial installation applications.

#QUQL30  
**\$59.95**

- 30-lb weight capacity
- Perfect for homes, stores, theaters, churches, and all kinds of commercial applications
- Heavy-duty, arc-welded steel construction
- Standardized mounting holes fit most popular speakers
- Tilt-and-swivel adjustable for exact directional positioning
- Non-reflective black enamel finish

- QL-30E** 4-hole speaker plate & 4-hole wall plate #QUQL30E ..... **\$69.95**
- QUQL60** 60-lb capacity, 4-hole speaker plate & 3-hole wall plate #QUQL60 ... **\$64.95**

**QUIKLOK**  
**QL-90**

**Tilt-Adjustable Speaker Wall Bracket**

The QuikLok QL-90 is a tilt-adjustable speaker wall bracket for speaker cabinets with 1-3/8" mounting hole with a distance from wall of 14.3".

- 75 lbs weight capacity (if stud mounted)
- Full tilt and side-to-side adjustment
- All-Steel Construction
- Available in black or white
- Optional corner mounting plate available (QL-90CK)

#QUQL90  
**\$57.95**



**ON-STAGE**  
**SS 7913B**

**Wall-Mount Speaker Bracket**

SS7913B is a wall-mount bracket designed for mounting speaker cabinets with 1 3/8" or 1 1/2" bottom mounting holes. Ideal for sound contractors, night clubs, and schools.

- 100 lbs weight capacity
- Applications: Small speaker cabinets
- Rectangular tubing
- Includes: screws for assembly, 1 3/8"- 1 1/2" adapter sleeve

#ONSS7913B  
**\$54.95**  
*per pair*

