



### XA10 Professional HD Camcorder

Ultra-compact, the XA10 shares nearly all the functionality of the XF100, but in an even smaller, run-and-gun form factor. 64GB internal flash drive and two SDXC-compatible card slots allow non-stop recording. Able to capture AVCHD video at bitrates up to 24Mbps, the camcorder's native 1920 x 1080 CMOS sensor also lets you choose 60i, 24p, PF30, and PF24 frame rates for customizing the look of your footage. Equipped with Genuine Canon 10x HD video lens, with lowlight sensitivity to f/1.8 and a zoom range of 30.4mm-304mm.

- Full image customization, cinema looks and infrared recording (for night shooting)
- HDMI/component/composite output.
- Dual XLR inputs, relay recording, waveform, color peaking, and zebra patterns.
- Detachable handles allows for truly low-profile shooting
- 3.5" Touch Panel LCD with Touch & Track, Touch Focus and Touch Exposure functions

**XA10 (CAXA10)**..... **Call or Log-on**      **XA10 in PAL (CAXA10P)**..... **1995.00**



### XF100 • XF105 HD 1920 x 1080 4:2:2 CCD Camcorders



The XF100 and XF105 feature 50Mbps MPEG-2 4:2:2 recording of 1920 x 1080 HD video onto Compact Flash (CF) cards. They utilize file-based MPEG-2 compression with an MXF File Wrapper to ensure full compatibility with existing industry infrastructure, metadata and non-linear editing systems. They are equipped with Canon 10x (30.4-304mm equivalent) HD lens; enable the easy set-up and capture of high-definition 3-D video when two XF100 or XF105's are paired; and have built-in infrared low-light enabling the capture of HD video in complete darkness. Otherwise the same, XF105 adds HD-SDI output, genlock, and SMPTE time code (I/O) terminals for multi-camera or 3-D productions.

**XF100 (CAXF100)**..... **Call or Log-on**      **XF105 (CAXF105)** ..... **Call or Log-on**

### XF100 • XF105 • XF300 • XF305 All Feature

- Hot-swappable dual card slots and support for UDMA CF cards
- Canon XF Codec is supported by Adobe, Apple, Avid, and Grass Valley to ensure compatibility
- Can record at multiple bit rates, resolutions and variable frame rates for slow and fast motion.
- XF100 and XF105 have 3.5" (920,000 dot) LCD monitor; the XF300 and XF305 have a rotating 4" 1.23-megapixel LCD monitor that can be positioned on right or left side of the camcorder.
- Built-in waveform monitor, XF300/XF305 add a vectorscope.
- 0.24", 260,000-dot (XF100/300) and 0.52" 1.55-megapixel color electronic viewfinder (XF300/305), for critical focus and 100% field-of-view coverage for accurate judgment of composition.
- Variable-interval (for time-lapse) and frame-record for stop-motion animation
- Built-in stereo mic as well as dual XLR inputs for external audio sources.

### XF300 • XF305

HD 1920 x 1080 4:2:2 3-CCD Camcorders

The XF300 and XF305 step up with three 1920 x 1080 CMOS sensors and Canon 18x HD (29.3-527.4mm equivalent) L-series lens and a full manual focus mode with mechanical "hard" end stops and distance markers for repeatable manual focus. HI-UD (high-index, ultra low dispersion), UD and aspherical lens elements minimize chromatic aberrations and provide a compact size and weight to the lens – while also delivering a resolution of 1000 TV lines. The lens incorporates SuperRange Optical Image Stabilizer (OIS) system with Dynamic and Powered modes for optimal performance in any situation. Otherwise the same, XF305 adds HD-SDI output, genlock, and SMPTE time code (I/O) terminals for multi-camera or 3-D productions.

**XF300 (CAXF300)** ..... **Call or Log-on**      **XF305 (CAXF305)**..... **Call or Log-on**



### Cinema EOS System

EOS C100 Digital Video Camera

C300 Digital Cinema Camera

EOS C500 4K Digital Cinema Camera



Canon's Cinema EOS System cameras are engineered to provide exceptional image creation capabilities for professionals in the motion picture, television, and other high-resolution digital production industries. They each feature a Super 35mm-equivalent 8.29-megapixel CMOS sensor, use MPEG-2 Full HD compression, employ 4:2:2 color sampling, and have a maximum recording rate of 50 Mbps. Compact bodies offers exceptional maneuverability, enabling shooting from vantage points all but inaccessible to large cinema cameras.

- Ideal for beginning filmmakers working on a budget, the C100 delivers full 1920 x 1080 HD video in the AVCHD format for compatibility with laptop and desktop editing systems. It has an EF mount making it compatible with over 70 zoom and prime lenses in Canon's EF, EF-S and EF Cinema lens lineups. Designed for extensive operational versatility, the EOS C100 features a mobile core configuration that allows users to add accessory parts according to their production needs.
- Stepping up, the EOS C300 is available in EF- and PL-mount versions and are equipped with four start/stop buttons positioned at various locations to satisfy any preferred camera-holding style, and can be outfitted with a host of accessories, including matte boxes, follow focuses and external video and audio recorders. They can be also be outfitted with a handle, grip, thumb rest and monitor unit.
- Available in EF- and PL-mount versions, the EOS C500 and C500 PLs are 4K (4096 x 2160-pixel) cinema cameras. 4K is particularly important for motion pictures that include scenes compositing live-action cinematography with high-resolution computer-generated imagery. The C500 and C500 PL output 4K resolution as a 10-bit uncompressed RAW data stream, as well as being able to output quad full-HD (3840 x 2160), 2K (2048 x 1080), full HD (1920 x 1080), and other imaging options.

**EOS C100** EF Cinema Camcorder Body (C100EF)..... **6499.00**  
**EOS C300** Cinema EOS Camcorder Body with EF Lens Mount (C300EF)..... **15999.00**  
**EOS C500** 4K Cinema EOS Camcorder Body with EF Lens Mount (C500EF)..... **25999.00**  
**EOS C300 PL** Cinema EOS Camcorder Body with PL Lens Mount (C300PL)..... **15999.00**  
**EOS C500 PL** 4K Cinema EOS Camcorder Body with PL Lens Mount (C500PL)..... **25999.00**

### EF Cinema Lenses

Engineered to meet or exceed the exacting standards of working professionals, every Canon EF Cinema lens is designed to fulfill contemporary 4K production standards, surpassing the performance requirements of any HD imaging system. Zoom lenses feature large aspherical lens elements to achieve sharp, consistent images in virtually every shooting situation. Geared inner focusing minimizes focus-induced changes in the angle of view, reducing focus breathing virtually to zero. 11-blade aperture diaphragms ensure beautiful bokeh – and innovative glass construction counteracts barrel expansion and contraction to avoid temperature-induced marking discrepancies. Each EF Cinema zoom lens or EF Cinema prime lens shares uniform gear position, diameter and rotation angle as well as front lens diameters, enabling the film crew to quickly change lenses without adjustment of the rig setup.



CN-E 14mm T3.1 EF Mount (CAE14EF)..... **5220.00**  
 CN-E 24mm T1.5 L EF Mount (CAE24EF)..... **5220.00**  
 CN-E 50mm T1.3 L EF Mount (CAE50EF)..... **4950.00**  
 CN-E 85mm T1.3 L EF Mount (CAE85EF)..... **4950.00**  
 CN-E 135mm T2.2 L EF Mount (CAE135EF)..... **4950.00**  
 CN-E 14.5-60mm T2.6 L in EF Mount (CAE14560EF) or PL Mount (CAE14560PL)..... **42750.00**  
 CN-E 15.5-47mm T2.8 L in EF Mount (CAE15547EF) or PL Mount (CAE15547PL)..... **23275.00**  
 CN-E30-105mm T2.8 L in EF Mount (CAE30105EF) or PL Mount (CAE30105PL)..... **23275.00**  
 CN-E 30-300mm T2.95-3.7 L in EF Mount (CAE30300EF) or PL Mount (CAE30300PL)..... **44650.00**

### Canon Accessories

**BP-955:** Li-ion battery (CABP955)..... **159.95**      **DC-920:** DC Coupler (CADC920)..... **19.99**  
**BP-975:** Li-ion battery (CABP975)..... **214.95**      **DC-930:** DC Cable (CADC930)..... **28.95**  
**BP-970G:** Li-ion battery (CABP970G)..... **141.99**      **D-Terminal to Component Video Cable**  
**Pearstone BP-970:** (PEBP970)..... **Call**      **(CADTC1000)**..... **38.99**  
**CA-930** AC Adapter (CACA930)..... **129.50**      **WD-H72:** 72mm 0.8x Wide Angle Converter  
**CA-940:** AC Adapter for EOS C300 & C300 PL      **Lens (CAWDH72)**..... **149.00**  
 Camcorders (CACA940)..... **249.95**      **TA100:** Tripod Adapter (CATA100)..... **149.95**  
**CB-920:** DC Adapter/Charger (CACB920) **109.99**      **TB-1:** Tripod Adapter Base (CATB1)..... **32.95**

**Canon Ikan Stealth-ENG EV2** Shoulder Mount System for XF-Series (CASMR)..... **619.95**

800-947-1186 | 212-444-6686



**GY-HM150U • GY-HM710U • GY-HM750U**

ProHD Memory Card Camcorders

The hand-held GY-HM150U and shoulder-mounted GY-HM710U/GY-HM750U are solid state 3-CCD camcorders that record 35Mbps HD video and uncompressed audio directly to SDHC media cards in the native Quicktime format used by Apple Final Cut Pro X, allowing instant editing of recorded material without file conversion.

The GY-HM150U features three 1/4" CCDs, integrated Fujinon 10:1 Zoom HD Lens and records 1920 x 1080, 1440 x 1080 and 1280 x 720p to SDHC and SDXC memory cards. It has a 2.8" LCD monitor (206,000 pixels), 0.44" electronic viewfinder (235,000 pixels) and HDMI output.



GY-HM750U

The GY-HM710U and GY-HM750U feature three 1/3" CCDs have a detachable 14x Canon HD lens and can also record video as AVI files. They also offer SD recording, 20-second Pre Rec (retro) recording, HD-SDI and IEEE1394 output, and image flip. (No 1280 x 720p on the GY-HM710U). Both come with 4.3" LCD monitor (410,000 pixels) and 0.45" LCOS electronic viewfinder (1.22 megapixels).

They have two SDHC memory card slots, for up to 64GB of on board storage—or 6 hours of continuous HD recording. They record on the second card when the first card is full. The GY-HM750U adds compatibility with SxS media (with optional KA-MR100G), and offers variable frame rate recording.



GY-HM150U

- GY-HM150U** Compact handheld 3-CCD camcorder (JVGYHM150)..... **1995.00**
- CTC-HM100SSC** Hard shipping case for the GY-HM150U (JVCHM100)..... **231.95**
- Remote Servo** for the GY-HM150U (JVHZHM150VZR)..... **Call or Log-on**
- Wide Conversion Lens Package:** for the GY-HM150U (JVHM100U169W)..... **Call or Log-on**
- GY-HM710U** with Canon 14x lens (JVGYHM710U)..... **5595.00**
- GY-HM750U** with Canon 14x lens (JVGYHM750U)..... **6895.00**
- KA-551U** Tripod adapter plate for JVC ProHD camcorders (JVKA551U)..... **295.00**
- Portabrace CTC-100B/SR** Travel camera case for GY-HM100U (JVCTC100BSR)..... **Call or Log-on**
- PortaBrace CTC-700B/S** Travel case for the GY-HM710U/750U (JVCTC700BS)..... **319.95**

**GY-HM790U** ProHD ENG / Studio Camera

Modular 3-CCD shoulder-mount HD video camera with solid state recording and studio functionality. Same as the GY-HM750U (except no simultaneous recording on 2 cards), the GY-HM790U is equipped with a 68-pin connector that allows modules to be attached without external cabling. The KA-M790 multi-core studio interface module offers a 26-pin interface compatible with JVC and Sony cables to connect with a CCU. For studio, the GY-HM790U can be handheld or fitted with the KA-790 sled to support a studio viewfinder, teleprompter and large lens.



- #JVGYHM790U (Body with 14:1 Canon Lens)..... **8995.00**
- #JVGYHM790CHU (Body Only—no lens)..... **8095.00**
- RM-HP790DU HD/SD Camera Control Unit (JVRMP790DU)..... **4720.00**
- VF-HP790 8.4" LCD Studio Viewfinder (JVVFHP790G)..... **4169.95**
- KA-790 Studio Sled (JVKA790G)..... **1899.00**
- KA-M790 Multicore Studio Interface Unit (JVKAM790G)..... **2620.00**
- SA-K790 Mounting Bracket for VF-HP790G Viewfinder (JVSAK790)..... **395.00**

- HZ-ZS13U** Rear Servo Zoom Control (JVHZS13U)..... **749.95**
- HZ-FM13U** Rear Manual Focus Control (JVHFM13U) ... **689.95**
- HZ-FM15U** Rear Manual Focus Control (JVHFM15U) ... **689.95**

**SR-HD1250 • SR-HD1500** Blu-Ray and HDD Recorder Combos

Copy videos to a Blu-ray disc from HD camcorder, from the HDD, or downconvert videos and record them onto a DVD. The internal HDD also enables easy editing and dubbing of multiple discs. The SR-HD1250 has a 250GB hard drive and includes component and HDMI outputs. The SR-HD1500 steps up with a 500GB hard drive, RS-232C and support for .MOV files (for Apple Final Cut Pro), making it compatible with footage recorded with the GY-HM150, GY-HM710 or GY-HM790U in the SP mode.



- SR-HD1250** (JVSARD1250US) and **SR-HD1500** (JVSARD1500US)..... **Call or Log-on**

**GY-HMQ10** Handheld 4K Camcorder

The GY-HMQ10 can capture and record real-time video at 4x the resolution of full HD—3840 x 2160 images at 24p, 50p and 60p. It incorporates a 8.3MP CMOS sensor and employs a razor sharp 10x zoom lens specifically designed for 4K imaging. Custom LSI chips deBayer the image and provide a live 4K output while simultaneously compressing video for recording onto memory cards. 4K recordings up to 2 hours can be made using four 32GB SDHC cards. The GY-HMQ10 can also record Full HD 1920 x 1080 on a single memory card in the AVCHD format.



Operation and form factor is similar to the GY-HM150U with manual or auto control of focus, iris, gain, shutter, gamma level, color matrix, and white balance. (JVGYHMQ10) ..... **4995.00**

**GY-HM600 • GY-MH650** Handheld ProHD Cameras

The GY-HM600 and GY-HM650 feature three, 1/3" 12-bit CMOS sensors (1920x1080 pixels each) and built-in Fujinon HD wide angle 23x zoom (29mm-667mm equiv) with manual focus, iris rings and an optical image stabilizer. The cameras have a 1.22 MP color viewfinder and color 3.5" LCD, offer sensitivity of F11 at 2000 lux and have time-code sync input as well as HD-SDI and HDMI outputs. They record HD or SD in native XDCAM EX (.MP4), Final Cut Pro (.MOV), and AVCHD, to two SDHC or SDXC cards.



A second trigger and servo zoom control makes it easy to record at low or high angles, while Pre Rec (retro cache) prevents missed shots.

They have built-in stereo mic, two XLR inputs with phantom power and a shotgun mic holder, as well as a headphone jack and separate input for a wireless mic receiver.

The GH-HM650 steps-up with dual codecs, so it can produce full HD files on one memory card while simultaneously creating smaller, Web-friendly files (1/4 HD) on a second card. You can then deliver the footage back to a station via built-in FTP and Wi-Fi—no microwave or satellite connection required.

- GY-HM600** ProHD Camera (JVGYHM600U)..... **4495.00**
- GY-HM650** ProHD Mobile News Camera (JVGYHM650U)..... **5695.00**
- SSL-JVC50:** 4900 mAh IDX Lithium-Ion Battery for GY-HM100 600/650 (JVSSLJVC50)..... **160.00**
- LC-2J:** Dual Charger for SSL-JVC50 Batteries (JVL2J)..... **160.00**

**GV-LS1 • GV-LS2** Live Streaming Cameras

12.4MP Back-illuminated CMOS image sensor and high-performance FALCONBRID processing engine team up to provide glitch-free low-latency Full HD 1920 x 1080 streaming. Audio is picked up by the internal stereo mic and connection of external microphone is also possible. Just insert a memory card in the SD Slot to record Full HD video. Built-in Wi-Fi allows you to wirelessly link them to the web for control via iPad/iPhone, tablet, smartphone or PC. Link up to four cameras, then easily switch from camera to camera and control any one at any time. Motion sensor-based automatic pan/tilt is also possible.



**GV-LS1 Only:** 4x digital zoom and electronic Pan/Tilt/Zoom. Splash-proof body is compliant to IPX3 standards so you can use it in a wider range of environments. (JVGVL1SBUS)..... **799.00**

**GV-LS2 Only:** Uses DD (Direct Drive) motors to provide near-silent panning/tilting. Quick and responsive, lateral movement of ±150° and -30° to +40° vertically means you can place in just about anywhere. Optical 10x zoom assures lossless high-quality close-ups. (JVGVL2WUS)..... **999.00**

**SR-HD2500** Blu-Ray Disc & HDD Recorder with HD-SDI

- For disc authoring, videos are transferred to the internal 500GB hard drive, then assembled into a completed project and recorded to Blu-ray disc via a simple, menu-driven interface. Record and author professional BDMV (with menu) or BDAV discs using BD-R or BD-RE discs.
  - Create a "window burn" of the time code embedded in the SDI signal.
  - Provides on-screen time and date information, even when there is no time code embedded in the SDI signal—useful for surveillance and law enforcement as well as academic and medical research.
  - Supports AVC H.264, MPEG-TS, and MPEG-2 video recording, plus Dolby Digital and Linear PCM audio recording. It accepts AVCHD camcorder files as well as .MOV files at 19, 25, and 35 Mbps.
  - HD/SD-SDI input, USB and i.Link (IEEE-1394) ports, as well as a SDHC card slot. Composite and S-Video inputs provide support for legacy analog devices. There are also HD-SDI, HDMI, and component outputs for flexible monitoring, and a RS-232 port for external control.
- #JVSARD2500US..... **Call or Log-on**



# Panasonic

## AG-HMR10 • AG-HCK10

Full HD Portable SD Card Recorder and Multi-Purpose Camera Head

Ideal for video production, sports, law enforcement, remote operation and surveillance, the AG-HMR10 is a hand-held, battery-operated portable recorder with HD-SDI I/O while the AG-HCK10 camera head features three 1/4" HD 3-MOS imagers, 12x optical zoom, and OIS (optical image stabilizer). When connected via supplied 3m detachable cable, iris, focus and zoom can be controlled from the recorder.



**AG-HMR10** (PAAGHMR10) ..... **Log-on**    **AG-HCK10** (PAAGHCK10) ..... **Log-on**  
**HMR10-HOOD:** LCD Hood for AG-HMR10 Recorder (PAHMR10HOOD) ..... **107.95**  
**HMR10-STAND:** Table Stand for AG-HMR10 Recorder (PAHMR10STAND) ..... **93.50**  
 10' Extension Cable (PAAGC20003G) ..... **304.99**    65' Extension Cable (PAAGC20020G) ..... **632.95**

## AG-AC7 Shoulder-Mount AVCHD Camcorder

Versatile, low-cost and lightweight (under 4 lbs.) professional AVCHD shoulder-mount camcorder featuring full HD (1920 x 1080) and SD (480i) recording to SDHC/SDXC cards. It features multiple recording formats and comes complete with a large grip and zoom lever, as well as a wide-diameter manual focus ring for smooth precise operation.

- 16.8x optical zoom (23x Intelligent Zoom)
- Intelligent Auto (iA) function plus full manual control of focus, iris, shutter speed, white balance
- On-screen assist functions (Zebra Pattern/Luminance Level/Histogram)

#PAAGAC7 ..... **Call or Log-on**



## AG-HMC80 3-Chip AVCCAM Shoulder-Mount HD Camcorder

- 3-megapixel 3MOS imager produces 1920 x 1080 or 1280 x 720 AVCHD video with high sensitivity.
- 12x optical zoom (40.8-490mm equivalent)
- Record 480i/p DV (60i, 30p, 24p) on SD cards with squeeze, letter box and side crop options.
- User-assignable manual focus ring (Focus/Iris/Zoom); time code/UB recording; time/date stamp; wired remote control terminals (zoom, focus, iris, REC start/stop controls).
- Two XLR inputs (mic/line) with +48v phantom power, built-in stereo mic, and external mic-in jack. Also HDMI output, USB 2.0, composite (BNC), analog component (BNC x3), and IEEE1394 output.
- Waveform monitor, focus assists, auto focus with face detection, zebra display, color bar, tally lamps, slow smooth zoom and soft landing, slow shutter and synchro-scan, and programmable user buttons.

#PAAGHMC80 ..... **Call or Log-on**



## AG-AC90 3-Chip AVCCAM HD Camcorders

Ideal for wedding and event, sports and corporate AV shoots, the AG-AC90 records in 1080/60p, 60i, 30p and 24p, as well as in standard definition (480/60i). It features high-sensitivity Full-HD 2.19 megapixel 3-MOS imagers 12x zoom lens, two SD card slots for simultaneous recording; five-axis image stabilizer that dramatically improves stabilization for hand-held shooting; and an intelligent Auto (iA) Zoom 25x super-resolution function for automatic adjustments of edge, gradation and detail.

- 12x zoom (29.8-357.6mm equivalent) lens with three independent adjustable rings for zoom, focus and iris, and Panasonic's exclusive Nano Surface Lens Coating reduces ghosting and flares.
- Advanced features include time code/UB recording; time/date stamp, and two wired remote control terminals (for zoom, focus, iris, REC start/stop controls).
- Equipped with a widescreen LCOS color viewfinder and a widescreen, 1.15-million pixel 3.5" LCD color monitor which can rotate 270° for easy low-angle, high-angle and self-interview shooting.
- HDMI output, USB 2.0 (mini B-type), Multi-AV output.
- For audio, has built-in stereo mic, two locking XLR inputs with switches for mic/line, two RCA audio outputs, and records two channels of Dolby Digital.

#PAAGAC90 ..... **Call or Log-on**



## AG-HMC40KIT 3-Chip AVCCAM Handheld Camcorder with 10.6MP Still Capability

- Just 2.2 lbs, 1/4" 3-MOS image sensors produce 1920 x 1080 HD video with high sensitivity.
- Leica Dicomar 12x optical zoom
- 2.7" rotatable (270°) touch panel LCD monitor
- Cine-Like Gamma mode
- Supports all 1080 and 720 modes including 23.98p
- Waveform monitor, focus assists, time date stamp, auto focus with face detection, zebra display, synchro-scan, programmable user buttons, time code/UB recording, and remote control terminal.
- HDMI and analog component out, ext. mic input, headphone jack, USB 2.0 interface
- Supplied AG-MYA30G XLR adapter offers 2-channel input (mic/line) with +48v phantom power.

#PAAGHMC40K ..... **Call or Log-on**



shown  
with optional  
shotgun mic

## AG-AC130A • AG-AC160A 3-Chip AVCCAM HD Camcorders

- Full-HD 2.2 megapixel 3-MOS imagers produce 1920 x 1080 or 1280 x 720 AVCHD video at high sensitivity.
- 22x zoom (28-616mm equivalent) lens with three independent adjustable rings for zoom, focus and iris.
- Optical Image Stabilizer, time code/UB recording; time/date stamp; and two wired remote control terminals (zoom, focus, iris, REC start/stop controls).
- Two SD slots for relay or simultaneous recording
- Widescreen 3.45" (921,000-pixel) LCD color monitor and 1,226,000-pixel LCOS color viewfinder
- Waveform and vectorscope display, focus assists, auto focus with face detection, zebra display, color bar, tally lamps, 4-position ND optical filter controls, slow shutter and synchro-scan shutter functions.
- HDMI output, USB 2.0, IEEE 1394 output and a built-in stereo mic. Two locking XLR inputs with switches for mic/line, two RCA audio outputs, and +48v phantom power capability.
- The AG-AC160 steps up with variable frame rate recording in 1080p for fast or slow-motion effects, Linear PCM audio, HD-SDI output and is 50Hz/60Hz switchable for worldwide use.

#PAAGAC130A ..... **Log-on**    #PAAGAC160A ..... **Log-on**    #PAAGHMC150 ..... **Log-on**



## HDC-Z10000 Integrated Twin-Lens 2D/3D Camcorder

Combines two large f1.5 lenses with two independent, high-sensitivity 3MOS sensors (left and right) for superb color and detail reproduction. Creates outstanding Full HD 3D video content (which can be viewed on any Panasonic consumer 3D TV) or 2D images. Offers 10x optical zoom (12x in 2D). 1,152,000-dot, 3.5-inch 3D LCD requires no 3D eyewear to view. Also features a 0.45-inch EVF. Three independent manual rings allow fine adjustment for the focus, zoom and iris. Shoot close-ups from 17.7" away

- Built-in microphones for recording Dolby Digital 5.1-channel surround sound/2-channel stereo, plus XLR audio inputs with a 48v phantom power.
- Dual SD card slots that can be deployed for either relay or back-up recording.

#PAHDCZ10000 ..... **Call or Log-on**



## AG-AF100A Micro 4/3" Professional HD Camcorder

Optimized for HD recording, the AF100A delivers the shallow depth of field and wider field of view of a large imager, with the flexibility and cost advantages of a handheld camcorder. The sensor has about the same imaging area as that of 35mm cinema film and achieves stunning, film-like images. With an interchangeable lens micro 4/3" mount, the AG-AF100A can utilize an array of low-cost still camera lenses as well as film-style lenses with fixed focal lengths, prime lenses, and zoom lenses.

- Records 1080/60p/60i/50i/30p/25p and 24p native) and 720 (60p, 50p, 30p, 25p and 24p native, utilizing AVCCAM's highest-quality PH mode (24Mbps)
- Variable frame rates in 24p, 30p and 25p in 1080p
- Uncompressed 10-bit 4:2:2, HD-SDI and HDMI output
- Built-in gamma curves including HD Norm, HD Low and High, Cine-like D, Cine-like V, B.Stretch
- With two card slots, use two 32GB SDHC cards and record for 6 hours with automatic clip spanning. Or use an 64GB SDXC card and record for 12 hours in PH Mode, and 48 hours in HG Mode.

#PAAGAF100A ..... **Call or Log-on**





**AG-HPX170**

1/3" 3-Chip P2 HD Handheld Camcorder

- 13x Leica Dicomar (28-364mm equivalent) lens and a cam-driven manual zoom for smooth, precise operation. Provides auto or manual focus and iris.
- 20-step frame rate selection in 720p mode for fast- or slow-motion in-camera effects
- Variety of advanced gamma functions and settings including a CineGamma mode.
- HD/SD-SDI output for live feed, editing and monitoring. Also has IEEE1394 and USB 2.0 interfaces.
- Records in 20 HD and SD formats and is switchable between 16:9/4:3 aspect ratios.



#PAAGHPX1700 ..... **Call or Log-on**

**AG-HPX255**

1/3" 3-Chip P2 HD Handheld Camcorder

- Full-HD 2.2 megapixel 3-MOS imagers and a 20-bit DSP
- 10-bit, 4:2:2 independent-frame, full 1920 x 1080 resolution AVC-Intra recording at 100 Mb/s as well DVCPRO HD, DVCPRO50, DVCPRO and DV.
- 22x HD lens (28-616mm equivalent) with 3 adjustable rings and Optical Image Stabilizer (O.I.S.)
- Variable frame rate capability in 1080p up to 30fps as well as 720p up to 60fps for undercranking/overcranking to create fast or slow-motion effects.
- Genlock/timcode input for multi-camera operation, as well as an HD-SDI output, HDMI output, IEEE 1394 in/out, and two P2 card slots



#PAAGHPX255 ..... **Call or Log-on**

#PAAGHPX250 (AG-HPX250 P2 HD Handheld Camcorder) ..... **Call or Log-on**

**AG-HPX370** P2 HD Camcorder with AVC-Intra

- Three 1/3", full-HD 2.2 megapixel 3-MOS imagers for Full HD 1920 x 1080, 10-bit 4:2:2 master-quality HD recording.
- High-resolution recording using AVC-Intra and DVCPRO HD, plus SD recording in DVCPRO50, DVCPRO and DV formats for complete flexibility.
- Native 24p (23.98 fps) for indie film production
- Variable frame rates, Chromatic Aberration Compensation (CAC), built-in scan reverse, advanced gamma functions, waveform and vectorscope display and focus assist tools.
- LCOS color viewfinder (1,226,000-pixels) and 3.2" LCD color monitor (921,000-pixels)



#PAAGHPX370 (with 17x Fujinon HD Zoom Lens) ..... **Call or Log-on**

**AG-HPX600** 2/3" 3-CCD P2 HD Camcorder

Weighing less than 7 lbs. and using low power, the AG-HPX600 incorporates a 2/3 type MOS sensor to produce beautiful HD images. It offers high sensitivity of F12 and a S/N ratio of 59dB. It supports AVC-Intra100/50, DVCPRO HD, DVCPRO50, DVCPRO, and DV as standard. It is 50Hz/59.94 Hz switchable for worldwide use. Equipped with Chromatic Aberration Compensation (CAC), Dynamic Range Stretch (DRS) function, smart user interface, two P2 card slots and an SD card slot.



Shown with optional lens

#PAAGHPX600B (without lens) ..... **Call or Log-on**

**Optional Accessories for Panasonic Camcorders**

CGA-D54 Lithium-Ion Battery Pack (PACGRD54) .....	<b>122.50</b>
VW-VBG6 Rechargeable Li-Ion Battery (PAVWVBG6PPK) .....	<b>129.95</b>
VW-VBD19PPK: 7.2V, 186 mAh Lithium-Ion Snap-On Battery (PAVWVBD19PPK) .....	<b>93.95</b>
AG-B25 AC Power Adapter / Battery Charger (PAAGB25) .....	<b>169.95</b>
SHAN-TM700 Quick-Release Tripod Adapter (PASHANTM700) .....	<b>429.95</b>
SHAN-HPX300 Custom Shipping Case (PASHANHPX300) .....	<b>569.95</b>
<b>16GB F-Series</b> P2 Memory Card (PAAJPE016FG) .....	<b>379.99</b>
<b>32GB F-Series</b> P2 Memory Card (PAAJP2E032FG) .....	<b>459.00</b>
<b>64GB F-Series</b> P2 Memory Card (PAAJP2E064FG) .....	<b>649.99</b>



**AJ-PCD2GPJ**

Single-Slot P2 Memory Card Drive

Affordable single-slot P2 memory card drive designed for offloading footage in the field. Using two USB slots--one for data transfer, the other for power -- the drive lets you offload footage from a P2 card to any computer or laptop. Rugged and reliable, the AJ-PCD2GPJ works with all P2 cards and formats, and is Mac/Windows compatible.



#PAAJPCD2 ..... **Call or Log-on**

**AJ-PCD35** 5-Slot P2 Card Drive

When connected to your computer, the P2 cards appear as one drive, making it extremely easy to browse through video footage. The AJ-PCD35 can ingest up to five cards at once over FireWire or USB 2.0 with fast data transfer. It connects via a "PCI-e" card slot of a tower computer to support a peak transfer speed of up to 1.2 Gbits/sec. This is 3x faster than USB 2.0 and 1.5x faster than Firewire/1394b.



#PAAJPCD35 ..... **Call or Log-on**

**AJ-HPD24PJ** Portable P2 Deck

Lightweight (4.4 lbs), 1/2 rack-wide, 2 RU-high recorder for professional HD production. Outputs for HDMI and HD-SDI as well as composite video. The deck has two slots for P2 cards and acts as a USB 3.0 device. It has a 3.5" LCD screen that shows not only thumbnails and live playback video, but also a waveform and vectorscope. Featuring time code I/O as well as RS-422 control, the AJ-HPD24PJ is an NLE deck as well as a component in a live-event environment, recording the feed of a switcher. Set up a system that can record and play back 3D video using the HDMI output and the HD-SDI input of two AG-HPD24PJ decks.



#PAAJHPD24 ..... **Call or Log-on**

**AG-HMX100**

3D Compatible Digital A/V Mixer

Compact, all-in-one, digital AV mixer with a built-in HD/SD multi-format compatible video switcher, audio mixer, frame synchronizer and digital effector. It serves as a audio/video switcher, adds a variety of effects, and transmits signals — all by itself. Multi-View function displays all source images on a single monitor, while keeping the system configuration simple and clean. Can also operate as a 3D video switcher with dual SDI inputs. (PAAGHMX100) ..... **Call or Log-on**



**AW-HS50N** Compact HD/SD Live Switcher

Half-rack width 10-bit switcher ideal for use in mobile video production and AV facilities. Has 4 HD/SD-SDI and one HD DVI-D input and two HD/SD-SDI and one scalable DVI-D outputs. Built-in multi-viewer allows 4, 9, or 10 images on a single display. Features P-I-P with dissolve transitions, switchable up-conversion and color correction. Includes a chroma/linear keyer, a downstream keyer (DSK), auto or manual video transitions, wipe and PIP preset memories, and frame memories. (PAAVHS50) ..... **Call or Log-on**



**AV-HS410** 9-Input HD/SD Smart Switcher

Powerful and expandable, the AV-HS410 supports multiple video formats, including 1080/24psf. High-resolution 7" color LCD panel displays selected video inputs or outputs, menus and settings in an easy-to-read format, as well as the built-in waveform and vectorscope. MultiViewer configurations include 4, 5, 6, 9, 10 or 16 sections and support the display of time, audio level meters and 4:3 markers. Features a dual-channel video clip recorder/player, effects preview, linear, luminance and chroma keying, time-line editing and high-quality 3D and 2D transition effects for both background and key. (PAAVHS410) ..... **Call or Log-on**



## Panasonic

### AW-HE60H • AW-HE60S

#### Multiformat HD/SD Integrated PTZ Cameras

The AW-HE60H and AW-HE60S incorporate a highly-accurate pan-tilt head that offers precise, fast, fluid movement in all directions, enabling the capture of both slow and fast-moving objects without excessive vibration and bounce. They feature an 18X HD optical zoom plus 10X digital zoom, live video monitoring for remote preview and control, and a Night Mode for shooting in extremely low light using IR illumination. Also feature 3-step gamma correction, 7-step chroma level adjustment, 100 pre-set memories, up to 1/10,000 electronic shutter with synchro scan, tally light, and a ceiling mounting bracket.



Otherwise the same, the HE60H has an HDMI output making it ideal for HD videoconferencing and distance learning; the HE60S has HD/SD-SDI output and genlock, making it ideal for multi-camera systems as well as TV/cable production, sports, A/V and conference facilities, houses of worship, and staging applications. AW-HE60H with HDMI output (PAAWHE60HE)..... **4389.95**  
AW-HE60S with HD/SD-SDI (PAAWHE60SE)..... **4890.00**  
AW-RP50 Remote Camera Controller (PAAWRP50)..... **1990.00**

### AW-HE120

#### Multiformat HD/SD Integrated PTZ Camera

The AW-HE120 integrates super-smooth pan/tilt/zoom (PTZ) mechanisms within a unique ergonomic design, making it a cost-effective robotic camera solution for a wide range of applications. 1/3-type 2.2MP U.L.T. 3-MOS sensors enable Full HD superior picture quality and excellent color fidelity. It features a  $\pm 175^\circ$  panning range and tilt range from  $-30^\circ$  to  $+210^\circ$ , 20x optical zoom plus 10x digital zoom, 1000 lines of resolution, 60dB S/N ratio, 16-axis color correction, Panasonic DRS (Dynamic Range Stretch) and built-in remote-controllable four-position ND filter. Supports RS-422 serial and IP control, as well as direct and Web-based IP remote control, enabling the camera to be securely operated and adjusted remotely from a web browser.



#PAAWHE120K..... **Call or Log-on**



### ClearVIEW HD-19

#### Robotic PTZ Camera

Perfect for videoconferencing, distance learning, and live-event recording in houses of worship and other venues, motorized 19x optical zoom captures wide (58.1°) for small rooms as well as tight (3.2°) for long distances in larger rooms. 1.3 Megapixel 1/3-type Sony Exmor CMOS sensor offers high S/N, and very low minimum illumination of only 0.7 lux. SmartSHOT technology with adjustable image processing (AIP) means that the user can control the advanced digital signal processing (DSP) functions of the camera, which in turn results in an extremely crisp, detailed image with vibrant color. The camera features simultaneous HD analog component and SD analog composite outputs so you can monitor the camera locally on any monitor as the camera sends high-quality HD video (1080p, 1080i, and 720p are selectable) to the rest of the video system.



ClearVIEW HD-19 Robotic PTZ Camera (VACVHD19)..... **2744.50**  
ClearVIEW HD-18 Hi-Def 1/3" PTZ Camera (VACVHD18)..... **3099.95**  
CeilingVIEW HD HideAway for ClearVIEW (VACVHDHA)..... **1479.50**  
Toshiba IK-HR1H CMOS HD Camera Head (TOIKHR1H)..... **1899.50**

### EVI-D70 PTZ Color Video Camera

Pan/Tilt/Zoom remote desktop or ceiling-mounted camera with a 1/4" EXview HAD image sensor, 18x zoom lens, image inverting capability, high-speed yet quiet direct drive operation, and six camera position presets. It includes a wireless remote and can be controlled by optional RS-232C and RS-422 serial controllers.



In Black (SOEVID70) or White (SOEVID70W)..... **835.00**

Vaddio Wall Mount Bracket in Black (VATPWMB70B)..... **43.95**

Vaddio Wall Mount Bracket in White (VATPWMB70W)..... **43.95**

### EVI-D80 • EVI-D90

#### PTZ Color Video Cameras

The EVI-D80 (18x) and EVI-D90 (28x) can pan 170° in either direction at up to 100° a second. They feature a 1/4" EXview HAD CCD, composite and S-Video outputs, six presets, and can be controlled via RS-232 or RS-422 or by included IR remote. E-Flip ensures images are displayed right-side up



EVI-D80 18x PTZ Camera (SOEVID80)..... **820.00**

EVI-D90 28x PTZ Camera (SOEVID90)..... **925.00**

EVI-D90 in White (SOEVID90W)..... **925.00**

EVI-H100S in Black (SOEVIH100S), White (SOEVIH100SW)..... **2725.00**

EVI-H100V in Black (SOEVIH100V), White (SOEVIH100VW)..... **2665.00**

### EVI-HD3V • EVI-HD7V

#### 720P and 1080P HD PTZ Cameras

Both use a 2MP 1/3" CMOS sensor to produce high-resolution images. They incorporate a DVI-I output to produce component or RGB. DVI-I is HDMI as well as VGA (component) compatible with simple adapters.



They feature 10x optical zoom/wide angle lens, smooth, high-speed pan/tilt operation and six position presets. Camera settings and pan/tilt/zoom functions can be performed remotely at high speed via the RS-232C interface.

EVI-HD3V 720p PTZ Camera (SOEVIHD3V)..... **1980.00**

EVI-HD7V 1080p PTZ Camera (SOEVIHD7V)..... **2120.00**

### BRC-300

#### 3-CCD PTZ Color Camera

Provides high-quality, low-noise SD images in 4:3 and 16:9. 12x autofocus optical zoom with wide-range pan/tilt/zoom capability. Controlled from a PC via RS-232 or RS-422. Integrates into S-Video, RGB, iLINK, fiber or SDI systems.



#SOBR300 (3-CCD PTZ Camera)..... **Call or Log-on**

#SOBRBK302 (Uncompressed SDI Video Card)..... **Call or Log-on**

Vaddio Thin Profile Wall Mount Bracket (VATPWMB300)..... **82.50**

### BRC-Z330 High Definition PTZ Camera

Designed for a wide variety of remote video applications, features a 1/3" 2-MegaPixel CMOS image sensor and 18x optical zoom lens. Simultaneously delivers high definition images in 1080i and 720p, while still able to output standard definition.



#SOBRZ330..... **Call or Log-on**

BRC-H900 1/2" HD 3CMOS Camera (SOBRCH900)..... **11900.00**

## SONY

### HXR-MC1

#### HD POV Camera and Recording System

Compact full high-definition point-of-view (POV) camera, the HXR-MC1 consists of a tiny splash-proof camera system and a handheld controlling unit with LCD panel and recording function. The unique style of the HXR-MC1 enables shooting in extraordinary angles, such as shooting sports from the user's point of view and onboard shooting in motor sports. Thanks to the LCD-equipped main unit, once the shot is taken, users can check the material immediately. (OHRMC1)..... **1795.00**



### EVI-HD1 High-Definition PTZ Color Camera

Flexible full 1080i HD remote Pan/Tilt/Zoom camera featuring 1/3" CMOS (2 MP) image sensor, 10x optical wide angle zoom lens, and HD-SDI output. In fact, you can output in one of 14 formats – eight HD and six standard definition. Direct drive motor ensures quick but quiet movement.



#SOEVIHD1..... **2496.00**

Vaddio Thin Profile Wall Mount Bracket (VATPWMBHD1)..... **99.00**

### EVI-D100 PTZ Color Video Camera

Wide-angle lens and quiet, high-speed direct drive operation makes it ideal for small, closed-in venues. Features 1/4" CCD, 10x optical zoom, and six position presets. Includes wireless remote control, or can be controlled by optional VISCA/RS-232C serial controllers.



#SOEVD100..... **780.00**

#SORC815 (50' VISCA/RS-232 Control Cable for EVI-D100)..... **59.95**

Vaddio Wall Mount Bracket in Black (VATPWMBD100B)..... **43.95**

Vaddio Wall Mount Bracket in White (VATPWMBD100W)..... **43.95**

### BRC-H700 / BRC-Z700

#### 3-Chip PTZ HD Color Cameras

Compact HD 1080i cameras with wide pan and tilt ranges, Zeiss lenses, and fast, accurate movements. The highly sensitive BRC-H700 with 1/3" CCD sensors has the widest viewing angle in the BRC series. BRC-Z700 provides HD/SD output via 1/4" CMOS chips, 20x optical zoom, and a very quiet and precise motor.



#SOBRCH700 (BRC-H700 PTZ Camera)..... **Call or Log-on**

#SOBRZ700 (BRC-Z700 PTZ Camera)..... **Call or Log-on**

#SOHFBKHD1 (HD Digital & Analog SDI Output Board)..... **Call or Log-on**

#SOBRBKHD1 (HD/SD-SDI Output Card for BRC-Z700)..... **1415.00**

#SOHFBKSD1 (SD-SDI, Component, RGB & Composite)..... **Call or Log-on**

### RM-BR300 Joystick Remote Controller

The RM-BR300 has one input for each RS-232C and RS-422 serial port, and can control up to 7 EVI/BRC series cameras that are daisy-chained from one source camera in your system.



#SORMBR300 (RM-BR300 Joystick Controller)..... **Call or Log-on**

#SORC8931 (10' RS-232 Control Cable)..... **19.90**



**HXR-NX30** Palm Size NXCAM HD Camcorder with Projector

Captures AVCHD video in Full HD 1080p at 60 fps, as well as high-quality still images. Equipped with 96GB of flash memory, and NightShot capabilities. It supports all AVCHD recording formats at 28 Mbps. Ultra-wide angle Zeiss 10x optical zoom lens mounted within a gyroscope offers unbelievable image stabilization. Built-in light offers auxiliary light source for video or flash for still image capture. Offers timecode / UB recording & HDMI embedded timecode output. Dual XLR inputs with phantom power, stereo shotgun mic and level controls. Last, an integrated projector built into the back of the LCD display lets you project a 100" diagonal image on any flat, near-white surface. (SOHXRNX30U)... **1999.00**



**HXR-NX5U** NXCAM AVCHD Camcorder

Three 1/3" Exmor CMOS sensors and 20x "G" lens deliver Full HD resolution and low light sensitivity (1.5 lux) with low noise. Records AVCHD up to 24Mbps along with 1080/24p, 720/60p and MPEG-2. Offers a choice of bit rates (24/17/9 or 5 Mbps), as well as selectable audio recording – Dolby Digital stereo or Linear PCM stereo which provides uncompressed audio quality. Has 3.2" (16:9) Xtra Fine LCD (921K dots) and 0.45" Xtra Fine electronic viewfinder (1,227,000 pixels). Features Active SteadyShot, SMPTE timecode I/O and GPS functions. Dual memory card slots as well as simultaneous hybrid recording using the optional HXR-FMU128 flash memory unit. #SOHXRNX5U..... **3999.00** HXR-NX5P "PAL" (SOHXRNX5P)..... **3995.00**



**HXR-NX70U** Compact NXCAM Rain-and Dust-proof Camcorder

Sealed body makes it ideal for documentary and news videographers traveling to far-flung, unpredictable locations. Exmor R CMOS sensor combines with ultra wide 10x Sony G lens and Optical SteadyShot to provide outstanding full HD 1080p video even in low light. 24p recording along with CinemaTone technology for realistic, film-like skin tones. Shoot 12.3MP stills while recording video. Manual focus, zoom or iris. Zebra and peaking indicators can be viewed through the large viewfinder or 3.5" touchscreen LCD. Detachable handle with dual XLR inputs – and an on-camera shotgun mic. Built-in GPS receiver lets you "tag" locations, with data extractable to a PC and mappable via Google's mapping service. Record to 96GB memory, Memory Stick or SDHC. #SOHXRNX70U..... **2799.00** HXR-NX70E "PAL" (SOHXRNX70E)..... **3149.95**



**HXR-NX3D1** NXCAM 3D Compact Camcorder

Record stereoscopic 3D video at Full HD 1920 x 1080 resolution. Camera features HD native Exmor R CMOS sensor, 12x Sony "G" lens (10x in 3D mode), and solid-state recording of AVCHD in many formats. 3.5" lenticular LCD display lets you monitor the stereo effect while you're shooting – without any glasses. You can also view just the left image, right image, or a composite mix of both, "flattened" so you can eyeball the disparity between the left and right video channels. Since handheld 3D image stabilization is crucial, Sony's Optical Steady Shot corrects camera shake in three parameters: up/down, left/right, and rotational. #SOHXRNX3D1U..... **Call or Log-on**



**HDR-AX2000** AVCHD Camcorder

Three Sony 1/3" Exmor CMOS sensors and 20x G lens with Active SteadyShot stabilization deliver full high-definition resolution and 1.5 lux low light sensitivity with low noise. The camcorder will record AVCHD up to 24Mbps, delivering 1920 x 1080 HD images with both interlace and progressive modes along with native 1080/24p, 720/60p and MPEG-2 standard definition recording. Features 3.2" (16:9) Xtra Fine LCD with 921,000 pixels and 0.45" Xtra Fine EVF with 1,227,000 pixels. Three built-in ND filters, plus manual settings for iris, gain, white balance, shutter speed and focus. Record button on the handle as well as on the side grip. Two slots for Memory Stick Pro Duo and SD/SDHC cards. Dual XLR inputs, and HDMI, component, and S-Video outputs. #SOHDRAX2000H..... **3498.00** HDR-AX2000E "PAL" (SOHDRAX2000E) **3399.00**



**HDR-FX1000** 3-CMOS HDV Camcorder

- 1/3" ClearVid CMOS image sensors with Exmor technology capture sharp, detailed images even in low light (to 1.5 lux).
- 24p progressive scan mode plus CinemaTone Gamma and CinemaTone Color give footage an even more film-like feel.
- 20x G-Lens (29.5-590mm) optical zoom lens with three built-in ND filters and three manual rings.
- 3.2" Xtra Fine LCD display (921k pixels)
- Smooth slow record • Manual gain, shutter and white balance

#SOHDRFX1000..... **3198.00** HDR-FX1000E "PAL" (SOHDRFX1000E)..... **3148.00**



**HDR-FX7** 3-CMOS HDV Camcorder

- 3CMOS sensor capture stunning HDV 1080i video
- Simultaneously record HD video and still images
- Carl Zeiss 20x HD optical lens plus a 1.5x digital extender available throughout the entire zoom range
- Manual zoom and focus rings • Smooth slow record
- Super SteadyShot optical stabilization system
- 3.5" wide (16:9) Hybrid Clear Photo LCD Plus display

#SOHDRFX7..... **Call or Log-on**



**HVR-Z5U** 3-CMOS Handheld HDV Camcorder

- 3 ClearVid™ CMOS Sensor system with Exmor technology for excellent low-light sensitivity
- Sony 20x "G Lens" (29.5-590mm) wide-angle zoom offers a field of view ideal for many shooting situations.
- Zoom, focus, and iris control rings using one hand. Built-in digital extender increases zoom to 30x while optical Super SteadyShot system lets you achieve a stable picture.

#SOHVRZ5U..... **Call or Log-on** HVR-Z5P "PAL" (SOHVRZ5P)..... **3795.00**



**HVR-Z5U • HVR-Z7U • HVR-S270U All Feature**

- They can switch between HDV 1080i, DV CAM, and standard DV recording for supreme flexibility.
- They can convert 1080i material down to 480i and output via i.LINK interface or other SD connectors.
- HDV can also be recorded as a memory file on CompactFlash cards using the supplied (optional with the HVR-Z5U) HVR-MRC1K Memory Recording Unit. Store over two hours of HDV on a 32GB card.
- They feature 24p/30p HDV native progressive recording and 24p/30p progressive scan mode
- They are equipped with Sony's 3.2" XtraFine LCD (921,000 pixels) and 0.45" XtraFine EVF

**HVR-Z7U • HVR-S270U**

3-CMOS Handheld and Shoulder-Mount Interchangeable Lens HDV Camcorders

The handheld HVR-Z7U and shoulder-mounted HVR-S270U step up from the HVR-Z5U with a 1/3" bayonet interchangeable lens system. This allows the use of a wide range of lenses from Canon and Fujinon. Both come standard with a 12x Zeiss lens for HD video. The HVR-Z7U uses InfoLithium batteries and has an HDMI output. The HVR-S270U uses BP-GL65 or BP-GL95 batteries, has four-channel audio input, HD/SD-SDI output, and also supports standard-size cassettes for extended recording times (up to 4.5 hours).

HVR-Z7U (SOHVRZ7U)..... **Call or Log-on** HVR-S270U (SOHVRZ270U)..... **6995.00**



**HXR-MC2000U** Shoulder Mount AVCHD Camcorder

Resting comfortably on your shoulder for steady handheld shooting, the HXR-MC2000U features a single Exmor R CMOS sensor with ClearVid Array for exceptional low-light performance, 12x wide angle optical zoom "G" lens, Optical SteadyShot with Active Mode and 2.7" PhotoPlus Touch Screen. Ergonomically designed handle contains a record button and zoom control, essential for low position shooting. Can record up to 13 hours in FH mode with a single NP-F970 battery to 64GB memory, or to Memory Stick Pro Duo or SD/SDHC cards. Can also record standard definition MPEG-2. (SOHXRMC2000U)..... **1699.00** HXR-MC1500E Shoulder Mount "PAL" AVCHD Camcorder (SOHXRMC1500P)..... **1495.00**



## SONY

**GV-HD700** HDV Portable Video Walkman

Record SD resolution and playback HDV resolution, view content on its built-in 7" 16:9 color LCD screen, or output 1080i/720p HD video to an HD display via the HDMI output. Features crystal clear still/slow-motion playback, MiniDV SP/LP record/playback, IEEE-1394 (DV) interface, component output, and 12-bit/16-bit PCM digital audio recording. Capture digital still images from tape, analog or i.LINK input, directly onto Memory Stick Duo media. (SOGVHD700)..... **1149.00**  
 #SOGVHD700E (GV-HD700 "PAL")..... **1199.99**

**HVR-M15AU • HVR-M25AU • HVR-M35AU**

## HDV Videocassette Recorders

HVR-M15AU



They offer HDV 1080i, DVCAM, and DV SP recording and playback on mini-size DV as well as standard-size cassettes. They can convert material from 1080i down to 480i and 576i, and output these signals via their i.LINK, analog component, composite or S-Video connectors.

- Three types of color bars and 1kHz audio tone
- Built-in tape cleaner helps prevent signal dropouts and improve recording and playback.
- Compact and unobtrusive, the HVR-M15AU is can be placed horizontally or vertically.
- The HVR-M25AU adds a 2.7" wide ClearPhoto LCD and an HDMI output. DUPLICATE PLUS function makes it easy to copy video and audio from an i.LINK compatible VCR or camcorder.
- The HVR-M35AU adds support for "native progressive" recording modes, down-conversion playback, and has HD/SD-SDI output with embedded audio and timecode data. It can play back the 4-channel audio data in HDV 1080i format as well as the four-channel audio data in DVCAM format.

**HVR-M15AU** (SOHVRM15AU)..... **Log-on**    **HVR-M25AU** (SOHVRM25AU)..... **Log-on**  
**HVR-M35AU** (SOHVRM35U)..... **Log-on**    **HVR-1500A** (SOHVR1500A)..... **7495.00**  
**Sony 3-Year Extended Warranty for Professional VCRs up to \$10,000** (SOEWD)..... **139.00**

**HDV & XDCAM Camera Accessories**

SxS-1 G1A: 32GB Memory Card (SOSBS32G1A)..... **356.00**  
 SxS-1 G1A: 64GB Memory Card (SOSBS64G1A)..... **598.00**  
 64GB SxS PRO Memory Card (SOSBP64A)..... **1099.99**  
 NP-F970: Info-Lithium Battery Pack (SONPF970)..... **Call or Log-on**  
 NP-F970 Info-Lithium Battery 2 Pack (SO2NPF970B)..... **249.95**  
 AC-VQ1051D AC Adapter/Twin Charger For L-Series Batteries (SOACVQ1051D)..... **88.89**  
 BP-GL65: 65WH lithium-ion V-mount battery with info function (SOBPL65)..... **316.95**  
 BP-GL95: 95WH lithium-ion V-mount battery with info function (SOBPL95)..... **599.95**  
 BP-L60S: 65WH lithium-ion V-mount battery pack (SOBPL60S)..... **399.95**  
 BP-L80S: 83WH lithium-ion V-mount battery pack (SOBPL80S)..... **579.95**  
 AC-DN10: AC adapter/charger – V-mount mechanism, 4-pin XLR (SOACDN10)..... **624.95**  
 BP-U30: 23WH lithium-ion battery with info function for PMW-EX1R/EX3 (SOBPU30)..... **144.95**  
 BP-U60: 56WH lithium-ion battery with info function for PMW-EX1R/EX3 (SOBPU60)..... **269.95**  
 BP-U90: 85WH lithium-ion battery with info function for PMW-EX1R/EX3 (SOBPU90)..... **425.00**  
 BC-U1: Battery charger for BP-U Series batteries (SOBCU1)..... **168.95**  
 BC-U2: Dual battery charger for BP-U Series batteries (SOBCU2)..... **339.95**  
 RM1BP: LANC Remote Control (SORM1BP)..... **219.95**  
 VCT-U14: Tripod adapter (SOVCTU14)..... **Log-on**    VCT-14: Tripod adapter (SOVCT14)..... **299.95**  
 LCEX3TH: Transit Case for PMW-EX3 (SOLEX3TH)..... **319.95**  
 LCEX1AME: Ameripack Hard Transit Case for PMW-EX1 (SOLEX1AME)..... **289.95**  
 LC-424TH Shipping Case (SOLC424TH)..... **389.95**  
 SHL-32W LCD Hood (SOSHL32W)..... **42.00**  
 SHL-32WBP: LCD Hood for 3.2" LCD (SOSHL32WBP)..... **64.95**  
 VCL-EX0877: 0.8x W/A Lens Adapter for PMW-EX1 (SOVCLX0877)..... **Call or Log-on**  
 VCL-HG0872K Wide Conversion Lens Kit for HVR-Z5U (SOVCLHG0872K)..... **699.95**  
 PROTECH ST-1: Press Shooter Tripod Adapter Plate (SOST1)..... **144.95**  
 VCT-SP2BP Camcorder Support (SOVCTSP2BP)..... **479.95**  
 NIPROS ST-7: Shoulder Mount Adapter for PMW-EX1/3 (SOST7)..... **899.95**  
 HVL-LBP Battery-Powered LED Light (HVLBPB)..... **525.00**  
 3-Year Ext. Warranty for cameras up to \$10,000 (SOEWC)..... **139.95**

**HXR-FMU128** 128GB Flash Memory Unit

Designed exclusively for the HXR-NX5U, the HXR-FMU128 enables hybrid recording of video footage. 128GB storage capacity provides continuous recording for up to 11 hours at the highest bit-rate—making it ideal for recording music festivals, seminars, and weddings, and for making documentaries. (SOHXRFMU128)..... **639.95**

**HVR-MRC1:** CompactFlash Recording Unit (SOHVRMRC1)..... **749.00**

**PMW-100** XDCAM HD422 Handheld Camcorder

Shoot broadcast-quality 50 Mb/s MPEG-2 recording with a camera that weighs under 4 lbs. Extremely sensitive, 1920 x 1080 CMOS sensor makes the camcorder suitable for low-light videography. NightShot function extends that functionality to complete darkness; built-in infrared LED illuminates the dead of night. Built in 10x zoom lens with manual control, HD/SD-SDI output, timecode I/O and genlock in. There are also dual XLRs for audio, composite video out, and HDMI out. There are six standard curves and four HyperGamma settings, which match those of Sony's high-end CineAlta cameras. Cache recording up to 15 seconds is available. Two SxS slots allow you to record up to 240 minutes even at the highest quality. #SOPMW100 (without SxS Memory Card PRO)..... **3980.00**

**PMW-200** 3CMOS XDCAM HD422 Camcorder

The PMW-200 features three 1/2" Full HD 1920 x 1080 Exmor CMOS sensors for high sensitivity of F11 at 2000 lux, low 56dB noise and a wide dynamic range. It has a 14x fixed zoom lens (servo/manual) with unique focus ring mechanism, and dual ExpressCard SxS memory card slots for up to four hours of 50 Mbps MPEG HD422 recording. Other features include focus magnification, Slow/Quick motion playback, slow shutter, shutter angle settings, six Gamma and four HyperGamma settings, picture cache recording, and a USB port for using the camcorder as a card reader. It offers four-channel audio recording, as well as HD/SDI and composite/HD-Y outputs. #SOPMW200 (without SxS Memory Card PRO)..... **6299.00**  
**PMW-160** 3CMOS (1/3") XDCAM HD422 Camcorder (SOPMW160)..... **6299.00**

**PMW-EX3** 3CMOS XDCAM EX Pro HD Camcorder with Interchangeable Lens

Utilizing the same electronics as the PMW-EX1R, the PMW-EX3 features an interchangeable 1/2" lens mount, removable viewfinder, and easy-to-hold body with a retractable shoulder pad. Filmmakers and wildlife/event videographers requiring variable lenses can take advantage of the outside dials for peaking, brightness and contrast, a push-button frame rate dial, and zebra switches. Additionally, the PMW-EX3 features genlock and timecode in/out for multi-camera operation. #SOPMWEX3Q (without SxS Memory Card PRO)..... **8320.00**

**PMW-320**

## XDCAM EX Shoulder-Mount Camcorder

- Three 1/2 Full-HD CMOS sensors, multiple-format recording, 4-channel audio and solid state SxS workflow.
- Capture HQ 35Mbps Full HD 1920 x 1080 or 25Mbps DVCAM footage to SxS PRO or SxS-1 memory cards — storing over 4½ hours of MPEG-2 HD video on two 32GB cards.
- Scene file settings, adjustable gamma, and Matrix settings can be stored on memory cards.
- They are also studio-configurable, with timecode in/out, genlock in, HD/SD SDI and HDMI out.

#SOPMW320K (with Fujinon 16x Zoom Lens)..... **9990.00**

**PDW-U2** XDCAM USB 3.0 Drive

Compatible with XDCAM HD422, XDCAM HD, and XDCAM SD. Handles quad-layer (PFD-128QLW), DL disc (PFD-50DLA) and single-layer disc (PFD-23A). The PDW-U2 features a dual-channel head system that puts two optics on one head to achieve incredibly fast read and write speeds. Sits on your desk either horizontally or vertically and connects to your computer via USB 3.0, for extremely high data transfer speeds.

**PDW-U2** XDCAM drive with USB 3.0 (SOPDWU2)..... **4350.00**

**PDW-U1** XDCAM drive with USB 2.0 (SOPDWU1)..... **3200.00**

50GB rewritable XDCAM disc (SOPFD50)..... **49.95**

128GB Quad-layer XDCAM disc (SOPFD128)..... **79.95**

**Maxell** 23.3GB XDCAM disc (MAPDRE23SL)..... **17.49**

**Maxell** 50GB XDCAM disc (MAPDXPD50DL)..... **31.99**

**TDK** 23.3GB XDCAM disc (TDXP23Q)..... **18.99**



SONY

**NEX-VG30 • NEX-VG900**

Interchangeable Lens Camcorders

Stepping up from the NEX-VG20 (p. 287), the NEX-VG30 features the same 16.1MP Exmor CMOS sensor, BIONZ image processor, Quad Capsule Spatial Array mic, and the Sony E-mount. Plus, it adds XGA OLED Tru-Finder EVF (2,359,000 dots) with eye-sensor, Multi Interface shoe, Picture Effects, can record in 24p or 60p and offers an optional external XLR adapter. For added creative control, a seesaw lever allows slow, smooth zoom capability that is almost impossible to achieve when zooming manually. Extensive manual settings also give videographers greater control and comfort. For supreme imaging quality, the NEX-VG900 steps-up with a 24.3MP Exmor CMOS full-frame 35mm sensor to fully exploit the artistic potential of interchangeable lenses. Capture full-frame, 24MP still photos with RAW format support for all the post-processing flexibility. The sensor also allows the creation of distinctive 'bokeh' (defocus) effects; high sensitivity for extremely clear, low-noise images; and effortless reproduction of smooth, true tonal gradation.

- NEX-VG30** Body Only (SONEXVG30)..... **1798.00**
- NEX-VG30** w/18-200mm (SONEXVG30H)..**2698.00**
- NEX-VG30EH 'PAL'** with 18-200mm Power Zoom (SONEXVG30EH)..... **2489.95**
- NEX-VG900** Full-Frame Interchangeable Lens Camcorder Body Only (SONEXVG900)..... **3298.00**
- NEX-VG900E 'PAL'** Body Only (SONEXVG900E)..... **3149.00**



**NEX-EA50UH**

Interchangeable Lens Camcorder with 18-200mm Servo Zoom Lens

35mm large sensor camcorder with servo-controlled zoom lens capability, the NEX-A50UH's Exmor APS-C HD CMOS sensor produces high-quality images with low noise and high sensitivity in low light. It enables 1080 recording at 60i/p, 50i/p, 30p, 25p, or 24p. Camera incorporates Sony's E-mount interchangeable lens system, which enables auto focus, auto exposure and stabilization during video shooting.

- Use as DSLR and capture 16.1MP still pictures. Offers a dedicated shutter release button, a mechanical shutter to eliminate rolling shutter artifacts, and a hot shoe.
- Included 18-200mm f/3.5-6.3 servo zoom features a quiet auto focus motor, circular iris blades for pleasing bokeh, continuous variable iris and Optical Steady Shot image stabilization with Active Mode. Controlled by both the zoom rocker lever on the camcorder grip and the camera handle, as well as by the rocker on the lens itself and also via LANC remote controllers.
- Extendable shoulder pad allows users to quickly switch between handheld and shoulder configuration without needing any extra accessories.
- 2-channel XLR audio, Linear PCM audio, time code, user bit and built-in GPS. Sony's HXR-FMU128 flash memory unit can dock directly to the camcorder for simultaneous back-up recording.

**#SONEXEA50UH (includes ECM-XM1 shotgun microphone)..... 3599.00**



**NEX-FS100U** NXCAM Super 35mm Digital Motion Camcorder

Like the PMW-F3, the NEX-FS100U features an Exmor Super35 CMOS sensor and interchangeable lenses. But it doesn't support SDI or HDSLI, and instead of SxS cards, uses Memory Stick and SD/SDHC/SDXC media. The camera can record 1080p full HD video at 60, 30 and 24fps and bit rates as high as 28Mbps in the AVCHD format (can also record in SD MPEG-2 format). Uncompressed 4:2:2 footage with embedded SMPTE timecode can be output via HDMI. Over & Under Cranking function allows you to select a frame rate that's different than the one used for playback. 3.5-inch, 921,600-dot XtraFine LCD can be rotated for easy viewing from either side of the camera. Body Only (SONEXFS100U)..... **4999.00** With 18-200mm Lens (SONEXFS100UK)..**5599.00**



**NEX-FS700U** NXCAM Super 35mm Digital Motion Camcorder

The NEX-FS700U steps up with a4K resolution sensor – matching Hollywood film cameras and providing complete compatibility with cine-style film lenses. The sensor's large size also increases control over depth of field, and delivers higher sensitivity in low light, lower image noise, and an exceptional dynamic range. Able to shoot full 1080p video in a range of frame rates, it records AVCHD footage onto SD card/MemoryStick or via the FMU (flash memory unit) port. Or it can output 4:2:2 video via HDMI or 3G/HD-SDI to a recorder. Simultaneous recording to both is also possible when instant backup is called for. Can record bursts (8 to 16 seconds) of super-slow motion video at rates up to 960 fps. Full-resolution recording is possible at up to 240 fps; at 480 and 960 fps, resolution is reduced.

**NEX-FS700U** Body Only (SONEXFS700) **7999.00** With 18-200mm Lens (SONEXFS700UK)..**8599.00**



**PMW-F3K/RGB** Super 35mm XDCAM EX Camera

On par with Hollywood film cameras, the PMW-F3K's super 35mm-size CMOS sensor provides increased control over depth of field, higher sensitivity in low light, lower image noise, and an exceptional dynamic range. Included PL mount adapter allows use with a number of PL-mount cine lenses. Records natively to SxS cards, while dual-link HD-SDI ports let you output to an external recorder. Also features variable frame rates, multiple-format recording, slow shutter, and uncompressed PCM audio. 3D-LINK option allows two camcorders to be controlled simultaneously for 3D stereoscopic shooting.

- #SOPMWF3LRGB (with no lens)..... 13,960.00**
- #SOPMWF3KRGB (with 35mm, 50mm and 85mm lenses)..... 19,890.00**
- CBK-RGB01 S-Log Gamma Option for PMW-F3 (SOCBKRGB01)..... 899.00**



**PMW-F5 • PMW-F55**

CineAlta 4K Digital Cinema Camera

Featuring a modular and compact design for easy configuration, the PMW-F5 and PMW-F55 deliver unprecedented creative options for HD, 2K QFHD and 4K production. Both offer multi-codec support: Sony's XAVC MPEG-4AVC/H.264 format, SR codec (MPEG4 SSI), and XDCAM 50Mbps 4:2:2 codec. In-camera recording is to Sony's new SxS PRO+ memory card media (for the F55, 4K 60p; 422 10-bit XAVC and HD 422 10-bit XAVC High Frame Rate); and for the F5, HD XAVC and HD high frame rate). They can dual record in a number of different configurations: Record in parallel to a SxSPro+ card, to both SxS slots with the same or different codecs, and to SxS at the same time as to the AXS-R5 in RAW.

- The cameras are further distinguished by wide (14 stops) exposure latitude, high sensitivity, and low noise. The F55 adds a global shutter to eliminate rolling shutter skew and flash band, delivering the same color filter with ultra wide color gamut as the F65 for true color reproduction.
- Each features a 4K Super 35mm image sensor with a 4096 x 2160 resolution (11.6M total pixels).
- AXS-R5 RAW recorder allows shooters to capture super slow-motion imagery in up to 60p 4K RAW on AXS memory – for 2K RAW, up to 240fps with the F55; and up to 120 fps with the F5 – all without crop factor or loss of angle of view.
- PL-mount prime cine lens technology lets users choose cine optics from Angenieux, Canon, Zeiss, Cooke, FUJIFILM, Leica, Schneider Optics and others. Shooters can use still lenses by removing the supplied PL-mount adaptor. This makes it easy to accept adapters for Canon EF, Canon FD, Nikon DX, Nikon G, Leica M and even 2/3-inch broadcast B4 lenses.



- PMW-F5:** CineAlta Digital Cinema Camera (SOPMWF5)..... **16,490.00**
- PMW-F55:** CineAlta 4K Digital Cinema Camera (SOPMWF55)..... **28,990.00**
- DVF-EL100:** 0.7" OLED viewfinder with 1280 x 720 HD resolution (SODVFL100)..... **4930.00**
- DVF-L350:** 3.5-inch LCD viewfinder (SODVFL350)..... **3230.00**
- DVF-L700:** 7" Full HD Monitor (SODVFL700)..... **4499.95**
- PVM-X300:** 30" 4K Trimaster Monitor (SOPVMX300)..... **31,679.95**
- AXS-R5:** 16-bit RAW 4K and 2K Recorder (SOAXSR5)..... **5350.00**
- AXS-512S24:** 512GB Memory Card for AXS-R5 Recorder (SOAXS512S24)..... **1800.00**
- AXS-CR1:** USB 3.0 AXSM Memory Cards Reader (SOAXSCR1)..... **550.00**
- HXR-IFR5:** 4K Recording Interface f/FS700U (SOHXRIFR5)..... **Call or Log-on**

Sony's PL mount prime lenses are certified for 4K capture, and designed to minimize geometric distortion, vignetting and breathing. A nine-blade iris delivers beautiful bokeh and the focus rings rotate 240°. Series includes focal lengths of 20, 25, 35, 50, 85 and 135mm. For easy lens changes, each has the same T2.0 aperture, the same external diameter, matte box diameter, and gear locations for follow focus and aperture. All are the same height except for the 135mm lens.

- 3 Lens Kit with 20mm / 25mm / 135mm lenses (SOSCLPK3F)..... 11,500.00**
- 6 Lens kit with 20mm / 25mm / 35mm / 50mm /85mm and 135mm Lenses (SOSCLPK6F) ..20,900.00**

**PMW-50** SxS Field Deck

Lightweight (2.2 lbs.) but rugged handheld recorder/player. Playback and view content from an SxS memory card via two ExpressCard 34 slots, on its 3.5" LCD monitor. It also lets you copy the data from an SxS card to other storage devices; record an external SDI signal; or convert a signal from SDI to i.LINK. Supports MPEG HD422 50Mbps (MXF) and MPEG HD420 35Mbps (MP4). Runs on a BP-U series battery or 12v DC. Also accepts SD, MS and XQD cards. HD/SD-SDI inputs plus a host of outputs including analog composite, HD/SD-SDI, HDMI, analog audio, headphone, iLink and USB. Wi-Fi remote control capable with the optional CBK-WA01 adapter.

**#SOPMWF50..... 4900.00**





## Batteries &amp; Chargers

<b>ElipZ 10K:</b> 7.2v, 75 WH under the camera mounted lithium-ion battery (ANELIPZ10K).....	<b>178.59</b>
<b>ElipZ Desktop Charger</b> (ANEC).....	<b>159.95</b>
<b>ElipZ 10K Battery and ElipZ Charger</b> (ANELIPZ10KPK).....	<b>231.00</b>
<b>ElipZ Adapter Cables:</b>	
For HVR-Z1U (ANSHADPELPZ).....	<b>66.64</b>
For GL-2, XH-AI, XH-GI (ANCAADPELPZ).....	<b>64.95</b>
For GY-HM100 (ANJ100ADPELP).....	<b>79.00</b>
For AG-HMC150 (ANP150ADPELP).....	<b>79.09</b>
For AG-DVX100/A/B, HVX-200, HPX-170 (ANPADPELPZ).....	<b>75.95</b>
32" ElipZ Extension Cable (ANCAEXTELPZ).....	<b>30.00</b>
Power Adapter for DSLR Cameras (ANDSLRADPELP).....	<b>78.95</b>
<b>Dionic 90:</b> 90WH Lithium-ion battery (AND90).....	<b>399.00</b>
<b>Dionic-HC:</b> 91WH Lithium-ion battery (ANDHC).....	<b>455.00</b>
<b>HyTRON 50:</b> 50 WH NiMH battery (ANH50).....	<b>264.95</b>
<b>HyTRON 100:</b> 100 WH NiMH battery (ANH100).....	<b>379.75</b>
<b>HyTRON 140:</b> 140WH NiMH battery (ANH140).....	<b>475.00</b>
<b>Tandem-70:</b> On-camera AC adapter & charger (ANT70).....	<b>519.95</b>
<b>TWIN:</b> Two-position portable quick charger (ANTT).....	<b>609.95</b>
<b>T2:</b> Dual battery charger and AC adapter (ANTT2).....	<b>849.00</b>
<b>TM4:</b> Simultaneous four-position charger (ANTM4).....	<b>1599.00</b>
<b>TWQ:</b> Quad charger and AC adapter (ANTTWQ).....	<b>1099.00</b>
<b>Quad-2702:</b> Quad charger/AC with DDM (ANQ2702).....	<b>1300.00</b>
<b>D-2722:</b> Dual charger/AC adapter with DDM (AND2722).....	<b>1199.00</b>
<b>PSM-160:</b> AC adapter with 13.5v 60W output (ANPSM160).....	<b>262.00</b>



## Gold Mounts

<b>QR-GOLD:</b> Large universal plate (ANQRGOLD).....	<b>97.19</b>
<b>QRC-GOLD:</b> Compact universal plate (ANQRCGOLD).....	<b>109.95</b>
<b>QR-DSR:</b> Gold Mount for Sony DSR series (ANQRDSR).....	<b>169.00</b>
<b>QRC-BMD:</b> For Blackmagic Cinema Camera (ANQRCBMD).....	<b>249.00</b>
<b>QRC-CA940:</b> for Canon C300 (ANQRCA940).....	<b>329.00</b>
<b>QR-DP800:</b> For for Panasonic AG-DP800 (ANQRDP800).....	<b>167.53</b>
<b>QR-EX3:</b> Gold Mount for PMW-EX3 (ANQREX3).....	<b>159.95</b>
<b>QR-DSLR:</b> Power Solution for Canon DSLR (ANQRDSLR).....	<b>149.00</b>
<b>QR-SDH:</b> Gold Mount for Sony V-mount (ANQRSDH).....	<b>169.00</b>
<b>QR-UNIV:</b> Universal Gold Mount adapter (ANQRUNIV).....	<b>129.95</b>
<b>QR-A200:</b> For Sony DNV-A25/220/A225 (ANQRA200).....	<b>129.95</b>
<b>QRC-Dual:</b> PT Gold Mount for Sony PMW-F3 (ANQRCDPT).....	<b>179.00</b>
<b>QR-DXCM3A:</b> For Portable Monitors (ANQRDXCM3A).....	<b>154.95</b>
<b>QRC-EPIC:</b> Gold Mount for Red EPIC (ANQRCEPIC).....	<b>395.00</b>
<b>QR-HOTSWAPGM:</b> Hot-Swap Battery Plate (ANQRHSGM).....	<b>299.95</b>
Uni Pac Gold Mount Snap-On Battery Holder (ANUP).....	<b>219.95</b>
4 PowerTap Sandwich Adapter (ANQRQAADPT).....	<b>314.00</b>
4-pin XLR Snap-On Plate for Gold Mounts (ANSOXLR).....	<b>109.00</b>

## On-Camera Lights &amp; Accessories

<b>EledZ:</b> 4.5w on-camera LED light (ANELEDZ).....	<b>319.95</b>
<b>EightZ:</b> 6v 10w on-camera halogen light (ANELIGHTZ).....	<b>145.04</b>
<b>UL2-6:</b> 25w Ultralight-2, 6" PowerTap cable (ANUL26).....	<b>242.95</b>
<b>UL2-20:</b> 25w Ultralight-2, 20" PowerTap cable (ANUL220).....	<b>259.00</b>
<b>ULHM-LED:</b> 9w LED head module (ANULHMLED).....	<b>399.00</b>
<b>UL2-20BASE:</b> Power base for the Ultralight-2 (ANUL220B).....	<b>144.95</b>
<b>UltraDAYlite</b> HMI On Camera Light (ANUDL).....	<b>944.95</b>
<b>UL2 LED Package:</b> Consists of ULHM-LED Head Module and UL2-20 Ultralight (ANUL2LEDPKG).....	<b>649.00</b>
<b>UL-DC:</b> Dichroic Filter for Ultralight-2 (ANULDC).....	<b>78.40</b>
<b>UL-DF:</b> Light Diffuser for Ultralight-2 (ANULDF).....	<b>61.95</b>
<b>UL-SB:</b> SoftBox for Ultralight-2 (ANULSB).....	<b>85.26</b>
<b>UL-WA:</b> Wide-Angle Adapter for Ultralight-2 (ANULWA).....	<b>61.95</b>
<b>XL-WEDGE:</b> Wedge Adapter for Ultralight-2 (ANXLWUL2).....	<b>44.95</b>
<b>PowerTap Multi:</b> Male-to-4 female receptacles (ANPTM).....	<b>84.95</b>
<b>PowerTap Plug</b> to 4-pin XLR Rt. Angle (ANPOWERTAP9X)....	<b>69.95</b>
<b>PowerTap Plug</b> to 4-pin XLR Lt. Angle (ANPOWERTAP9X)....	<b>69.95</b>
<b>PowerTap Kit:</b> Male pins and housings for PowerTap connection (ANPTK).....	<b>12.80</b>
<b>Female PowerTap Kit:</b> Adapts any 12v DC light to PowerTap (ANFPTK).....	<b>13.59</b>
<b>PT-FS4:</b> PowerTap to Firestore DR-HD100 power adapter cable (ANPTFS4).....	<b>49.95</b>
<b>PowerTap Open End:</b> 3' Male PowerTap power cable to open end (10 amp max) (ANPTOE).....	<b>44.99</b>
<b>PowerTap-36:</b> 36" PowerTap to XLR cable (ANPT36).....	<b>64.95</b>
<b>PTE:</b> PowerTap male to female 7' extension cable (ANPTE)....	<b>68.50</b>
10' XLR-4M to XLR-4F Power Cable (ANXLR4).....	<b>61.66</b>
28" PowerTap to 4-pin XLR-F cable for the original Ultralight (ANPT28).....	<b>56.00</b>

## Lead Acid Batteries

<b>BES-015NC:</b> Belt/shoulder mounted 12v DC 172WH battery with cigarette plug connector (BEBES015NC).....	<b>89.95</b>
As above, plus 4-pin XLR connector (BEBES015XLRN).....	<b>99.95</b>
<b>BES-018NC:</b> Belt/shoulder mounted 12v DC, 216WH battery with cigarette plug connector (BEBES018NC).....	<b>112.50</b>
Same as above, plus 4-pin XLR connector (BEBES018XLRN).....	<b>121.95</b>
<b>HP-3NC:</b> Belt/shoulder mounted 12v DC, 36WH battery with cigarette plug connector (BEHP3NC).....	<b>42.95</b>
Same as above, plus 4-pin XLR connectors (BEHP3XLRN).....	<b>54.95</b>
<b>MM-7NC:</b> Shoulder pack 12v DC, 108WH battery with cigarette plug connector (BEMM7NC).....	<b>55.95</b>
Same as above, plus 4-pin XLR connector (BEMM7XLRN).....	<b>75.95</b>
<b>MM-9NC:</b> Shoulder pack 12v DC, 108WH battery with cigarette plug connector (BEMM9NC).....	<b>59.95</b>
Same as above, plus 4-pin XLR connector (BEMM9XLRN).....	<b>82.95</b>
<b>MM-12NC:</b> Shoulder pack 12v DC, 144WH battery with cigarette plug connector (BEMM12NC).....	<b>88.95</b>
Same as above, plus 4-pin XLR connector (BEMM12XLRN).....	<b>99.95</b>
<b>PRB-7NC:</b> Backpack 12v DC, 84WH battery with cigarette plug connector (BEPRB7NC).....	<b>69.95</b>
<b>PRB-9NC:</b> Backpack 12v DC, 108WH battery with cigarette plug connector (BEPRB9NC).....	<b>64.95</b>
<b>PRB-12NC:</b> Backpack 12v DC, 144WH battery with cigarette plug connector (BEPRB12NC).....	<b>89.95</b>
As above, plus 4-pin XLR connector (BEPRB12XLRN).....	<b>109.00</b>
<b>PRB-15NC:</b> Backpack 12v DC, 173WH battery with cigarette plug and 4-pin XLR connector (BEPRB15XLRN).....	<b>119.95</b>
<b>PRB-154NC:</b> Heavy-duty backpack 12v DC, 173WH battery with cigarette plug connector (BEPRB154NC).....	<b>119.95</b>
As above, plus 4-pin XLR connector (BEPRB154XLRN).....	<b>119.95</b>
<b>PRB-18NC:</b> Backpack 12v DC, 216WH battery with cigarette and 4-Pin XLR connectors (BEPRB18XLRN).....	<b>138.50</b>
<b>PRB-24NC:</b> Heavy-duty backpack 12v DC, 288WH battery with cigarette plug connector (BEPRB24NC).....	<b>169.95</b>
As above, plus 4-pin XLR connector (BEPRB24XLRN).....	<b>174.95</b>
<b>SLM-5ATM:</b> Slimline 12v, 54WH lead acid battery belt with cigarette plug jack with ATM-PRB Charger (BESLM5ATM).....	<b>74.95</b>
<b>NMH-54NC:</b> "Side Kick" 12v DC NiMH battery, 54WH with cigarette plug connector (BENMH54NC).....	<b>79.95</b>
As above, plus 4-pin XLR connector (BENMH54XLRN).....	<b>99.95</b>
PV-BP88 12v, 2300mAh lead-acid battery (BEBP88).....	<b>29.95</b>
NP-1 Style Nicad battery (BEBPNP1).....	<b>69.95</b>
NP-1 Style NiMH battery (BEBPNP4).....	<b>89.95</b>
V-Mount 95WH li-ion battery (BEBPLI95).....	<b>224.95</b>



## Battery Chargers &amp; Power Supplies

Power supply for 4-Pin XLR equipment (BEPISA124).....	<b>146.72</b>
<b>CQ14</b> 14v quick charger with cigarette connector for battery-belts and shoulder-packs (BEBEQ14).....	<b>47.95</b>
<b>NMH-ATMX</b> Automatic charger for NiMH battery packs with 4-pin XLR connector (BENMHATMX).....	<b>79.95</b>
<b>ATM-PRU</b> Automatic universal charger (BEATMPRU).....	<b>39.95</b>
<b>NMH-ATM</b> Charger for NiMH batteries (BENMHATM).....	<b>74.95</b>
<b>AC to DC Adapter</b> allows any 120V AC powered device to receive power from a DC power source (BEACTODC).....	<b>7.00</b>

## Power Extension Cables

5' 4-pin XLR-M to 4-pin XLR-F cable (BEXLR5MF).....	<b>15.13</b>
10' 4-pin XLR-M to 4-pin XLR-F cable (BEXLR10MF).....	<b>21.95</b>
20' 4-pin XLR-M to 4-pin XLR-F cable (BEXLR20MF).....	<b>27.95</b>
16" 4-pin XLR-M to cigarette-F adapter cable (BEXLRCJ).....	<b>22.75</b>
16" 4-pin XLR-F to cigarette-M adapter cable (BEXLRCP).....	<b>21.95</b>
Cigarette-M to 2-cigarette-F Y-adapter (BEY21).....	<b>9.95</b>
10' cigarette plug power extension cable (BEBX10).....	<b>6.45</b>

## LED-70

## On-Camera 70w Video &amp; DSLR LED Light

Dimmable, daylight balanced (6500K) LED light with a compact form factor. Powered by 4 AA batteries or optional AC adapter, the unit's 96 LED bulbs produce a bright, 70w equivalent beam with a 30-ft. reach. Includes a clear frosted filter for softening glare and amber 4300°K correction filter for shooting indoors.



#BELED70.....	<b>79.95</b>
#BELED70B (LED-70 with Battery & Charger).....	<b>99.95</b>
<b>LED-125:</b> Dimmable 125W LED light (BELED125).....	<b>99.95</b>
<b>LED-125</b> with HP-3NC Battery & Charger (BELED125B).....	<b>173.95</b>
<b>LED-180:</b> Dimmable 180w LED light (BELED180).....	<b>148.95</b>
<b>LED-180</b> with HP-3NC Battery & Charger (BELED180B).....	<b>212.95</b>
<b>LED-180</b> w/NMH-54NC Battery & Charger (BELED180N).....	<b>293.95</b>

800-947-1186 | 212-444-6686

Power & Lighting



**Lux-LED 4** On-Board Camera Light

Featuring highly efficient LED technology, the compact and weather-resistant Lux-LED 4 generates greater brightness (250 Lux at 3-ft.) while consuming less power (4w) than standard tungsten on-board camera lights. Unique geometric spiral LED arrangement ensures even illumination. Fits on any camcorder using the standard shoe horn mounting. The provided D-Tap cable allows the light to be powered by camera batteries. Built-in dimmer as well as a focus slide mechanism that controls the illumination angle between 40° (spot) and 60° (flood).  
#BELLUXLED4.....**265.00**

**BOWER VL-12K**

Professional LED Light

Cool-running video light, you can adjust both intensity and color temperature to match the scene. Using a standard shoe mount to attach to your camera, 6500K beam can be corrected to 5600K or softened with the attached fold-out filters. Includes barndoors, NP-F750 type battery and charger. (BOLL).....**89.99**



**Cineroid**

**L10C-3K • L10C-5K**

3000K & 5400K On-Camera LED Lights

Lightweight, on-camera LED lights with a 3000K (Tungsten) or 5400K (Daylight) balance making them ideal for use with a camcorder or video-capable DSLR. Light-intensity control of the 120° beam via the 30-step dimmer with settings displayed in the LED window. They lights are powered by optional external 12v battery sources or camera batteries via the included battery plate.



#CIL10C3K (3000K Tungsten) ..... **239.00**  
#CIL10C5K (5400K Daylight) ..... **239.00**

**L2C-3K5K**

On-Camera LED Light (Tungsten/Daylight)

Use for video or video-capable DSLR lighting. Just 6.2 oz and the size of a Smartphone, the L2C-3K5K features a color temperature of 3,000 or 5400K and a 135° beam angle that you can compress using the supplied honeycomb grid. (CIL2C3K5K) ..... **529.00**



**Ledzilla** Mini LED Daylight Camera Light

Small on-board light focuses from -4° to 56°. Flip-up diffuser makes beam even wider. Convert from daylight to tungsten light using built-in dichroic filter. Adjustable support arm for positioning above and forward of the camera. Dims smoothly from full power to 0. Built-in barndoors. Power from any 6v to 18v source using optional cable, or mini-DV batteries with optional battery shoe. Front-end bayonet for attachments and light modifiers.  
#DEDLOBML ..... **529.00**  
#DEDLOBMLSH (same as above, plus battery shoe) ..... **574.95**



**DL-DV110C** Video & DSLR LED Light

Versatile on-camera light that attaches to your camera's shoe and allows you to set color temperature at any level between 3000K and 6000K. Light output is also variable. Comes with a rechargeable lithium-ion battery and charger and an adapter that lets you use 4AA batteries. (DODLDV110C) ..... **139.00**  
**DV112** On-Camera LED Light with Battery (DODLDV112)..... **99.95**  
**DV112A** On-Camera LED Light (DODLDV112A) ..... **71.48**  
**DL-DV60** Video & DSLR LED Light (DODLDV60Q)..... **88.99**  
**DL-DV60A** Video & DSLR LED Light (DODLDV60AQ)..... **59.95**



**DL-DV320C**

LED Light with Variable Color Temperature

Large, bright light for on-camera or light stand use. Composed of 256 LEDs, is equivalent to a 200w incandescent light. Four settings let you step down light output from full to 3/4, 1/2, and 1/4 strength. The light is rated at 5600K (daylight) and includes a filter for 3200K (tungsten). Includes a Sony NP-F750-style Li-Ion battery and a charger, or power it via the included AC adapter. (DODLDV320C) ..... **279.95**



**TC200-EX** 2-Position Battery Charger

- Fast, simultaneous charging of two batteries.
- Dynamic Power Management (DPM) minimizes battery charge time by alternating the current.
- 100–240v AC power supply

#DOTC200SQ (for Sony BP-U60 Batteries)..... **274.95**  
#DOTC200PQ (for 7.2v DC Panasonic AG-NMC150 batteries) .. **219.95**



**TC40** Four-Position Simultaneous Battery Charger:

for Panasonic CGR-D54 batteries (D04PCPQ)..... **344.95**  
for Panasonic VW-VB66 Batteries (D04PTDMCPQ1)..... **309.95**  
Panasonic Replacement DC Cable (DODCCP)..... **26.95**

**TC-400** 4-Position Battery Charger

- Fast, simultaneous charging of four battery packs
- Available with LCD screen that shows charge progress
- 100–240v AC power supply

#D04PCSX (for Sony EX-1 batteries) ..... **619.95**



**F L O L I G H T™**

**Microbeam 128 LED**

On-Camera 5600K, Spot Video Light

Weighing just 16 oz. and compatible with existing camcorder batteries, features a 100 - 0% dimmer and runs for hours on a Li-Ion battery. Includes color filter pack with 3200K filter.

Microbeam 128 LED w/Panasonic Plate (FLEED128PDS) ..... **259.00**  
Microbeam 128 LED w/Sony Plate (FLEED128SDF)..... **259.00**  
Sony Mount & Charger for 128/256 LED (FLEEDBATKIT)..... **79.95**

**Microbeam 256 LED:**

3200K Flood with Sony Battery Plate (FLEED256STF)..... **375.00**  
5600K Flood with Sony Battery Plate (FLEED256SDF)..... **375.00**  
5600K Flood with Panasonic Battery Plate (FLEED256PDF)..... **375.00**  
Microbeam 512 LED Gel holder (FLEEDGEL512)..... **25.00**  
Microbeam 1024 LED Gel holder (FLEEDGEL1024)..... **49.00**



**On-Camera Lights**

50w Mini-Fill Dimmer with PowerTap (FRMFICPT)..... **342.95**  
75w Mini-Fill Dimmer with 4-pin XLR (FRMFIC4X)..... **319.95**  
100w Mini-Fill Dimmer with Cigarette Plug (FRMFIC12P) ..... **345.95**



3" Stud with 1/4-20 Thread for Mini-Fill (FRLS1)..... **26.95**  
1.5" Stud with 1/4-20 Thread for Mini-Fill (FRLS1A) ..... **23.95**  
3" Stud with Shoe Mount for Mini-Fill (FRLS21)..... **29.95**  
1.5" Stud with Shoe Mount for Mini-Fill (FRLS21A)..... **32.95**  
Flip-Up Dichroic Filter for Mini-Fill (FRMFDF)..... **129.95**  
1/2" Stud to Shoe Mount Adapter (FRMS21A)..... **26.50**  
LED Lamp Kit for Frezzi Mini-Fill Lights (5000K) (FRMFLKC)..... **99.95**  
Power-Tap-Fto XLR-M Adapter Cable (FRACPTFLRM2) ..... **58.50**



**iLED 120**

On-Camera LED Light

Offers a bright, wide angle beam pattern and has a daylight color temperature of 5300-5900 K. Features an intensity slider control, a rechargeable on-board lithium battery, and multiple light stacking options. (IKILED120)..... **116.00**



**iLED 144** On-Camera Bi-Color LED Light

Produces a wide, bright beam with variable color temp (3200-5600K) for shooting indoors and out. Features a built-in dimmer, AC/DC power and long-lasting onboard Sony L-type battery. You can securely stack lights together to form a wall of LEDs. (IKILED144)..... **251.00**



**Multi-K** Variable Color Temperature LED Light

Dial in the color temperature you need, using a combination of three differently colored lights to provide a range of color temperatures from 2800-6500K. With case, shoe mount and AC adapter. (KMULTIK) ..... **314.00**



**iLED 312** On-Camera Dual-Color LED Light

Features variable color temperature (3200-5600K) for shooting indoors (tungsten) and out (daylight), a built-in dimmer, AC/DC power, two long-lasting onboard batteries (with dual charger), and a ball head mount for attaching the light to your camera's shoe. (IKILED312Q)..... **359.00**  
iLED-ONE-TK Table/Mini LED Light Kit (IKILEDONETK)..... **239.95**



**IBS-970:** Sony NP-F970 Replacement (IKIBS970) ..... **62.86**  
**IBC-950:** Canon BP-950G Replacement (IKIBC950G) ..... **62.86**  
Portable Charger for Sony L series batteries (IKICH750)..... **33.95**  
**IBS-U65** BP-U Ultra-High Capacity Battery (IKIBSU65)..... **161.00**  
**IB-L130A** Lithium-Ion AB Mount Battery (IKIBL130A)..... **330.00**  
**IB-L130S** Lithium-Ion V-Mount Battery (IKIBL130S)..... **329.95**



**ENDURA Series**

Lithium-Ion 14.4v V-Mount Batteries

Compact, lightweight high-power batteries with LED lamps for easy reference of remaining power.



- E-7S:** 71WH (IDE7S)..... **229.00**
- E-HL9S:** 88WH (IDEHL9S)..... **401.00**
- E-HL9:** 88WH with Digi-View Display (IDEHL9)..... **483.00**
- E-10:** 98WH (IDE10)..... **392.00**
- E-10S:** 98WH (IDE10S)..... **328.00**
- Elite:** 136WH with Digi-View Display (IDEE)..... **677.00**

**ENDURA Series Lithium-Ion Chargers**

- Single Channel V-plate Charger (IDVLPVC1)..... **249.95**  
2-battery (with 60w power supply) and 4-battery quick chargers
- VL-2 Plus:** 2-battery sequential charger (IDVL2)..... **425.00**
- VL-2S Plus:** 2-battery simultaneous charger (IDVL2S)..... **610.00**
- VL-4S:** 4-battery simultaneous charger (IDVL4S)..... **868.00**

14.4v NP-1 Style

Lithium-Ion Batteries & Chargers

- NP-L7S** NP-Style Lithium-Ion Battery (IDNPL7S)..... **217.00**
- JL-2Plus:** Dual NP-1 style (Nicad, NiMH or lithium-ion) sequential battery charger with 60w power supply (IDJL2P)..... **387.00**

DC Power Supplies

- Run on 100-240v AC 50/60 Hz and include 10' 4-pin XLR cable.
- IA-60A:** 1-Ch, 4.4 amp, 12v/60w (IDIA60A)..... **266.00**
- IA-200A:** 2-Ch, 7 amp, 12v/100w (IDIA200A)..... **467.00**

Lithium-Ion 7.4v Batteries & Charger

- SSL-VBG50:** 7.4v 5000mAh Lithium-ion battery for the Panasonic AG-HMC70, AG-HMC80 and AG-HMC150 (IDSSLVBG50)..... **133.00**
- LC-VWP:** Dual channel simultaneous charger for SSL-VBG50 batteries (IDLCVWP)..... **120.00**

Adapters, Brackets, Cables

- 10' 4-Pin XLR Power Extension Cable (IDCA4XLR)..... **35.00**
- DC-DC Cable for Canon EOS 7D / 5D Mark II (IDCEOSC)..... **142.00**
- A-NH2E:** Adapter Plate for NP/BB Batteries (IDANH2E)..... **49.00**
- A-AB2E Adapter Bracket:** Adapts an Anton Bauer Gold Mount battery plate to the IDX Endura V-Mount (IDAAB2E)..... **156.00**
- C-EB(XLR) Power Adapter:** Allows use of Endura V-Mount battery to power equipment via 4-pin XLR (IDCEB(XLR))..... **155.95**
- A-E2EX3:** ENDURA Battery Adapter for PMW-EX3 and PMW-EX30. Includes a 2 pin D-Tap 50W connector for simultaneously powering the IDX X5-Lite on-camera LED light (IDAE2EX3)..... **159.00**
- P-V2:** Convert most cameras to a V-Mount battery connection. Also has a 2 pin D-Tap output and Dig-View (IDPV2)..... **91.00**
- P-VS2:** As above, plus features Syncron-turns on-board light on and off in sync with a camera's record button (IDPVS2)..... **102.00**
- P-V212** Endura V-Mount Plate (IDPV212)..... **177.00**
- P-V257:** Endura V-Mount Plate (IDPV257)..... **177.00**



**X6 On-camera LED Light**

Flexible and lightweight, the unit's 63 super-white LEDs provide bright, daylight-balanced light outdoors. If you need to match interior lighting, a swing-away correction filter gives you the necessary tungsten balance. A built-in dimmer allows for smooth modulation of brightness level. Includes swiveling barndoors and is powered by four AA batteries



#LESWL63..... **184.95**



**Micro On-Camera LED Light**

Dimmable 5600K daylight 3w LED light powered by AA batteries or DV battery (with optional DV plate). Included filter lets you warm the illumination or change to 3200K tungsten. Integrated camera shoe with adjustable tilt mechanism allows for multiple mounting configurations.



- Micro:** 3W light without power (LILPMICRO)..... **198.00**
- MicroPro:** 9W LED light without power (LIMPLEDL)..... **315.00**
- Three piece gel set for the Micro (LILPMICROGEL)..... **22.50**
- Sony Battery Adapter Plate for Micro (LILPMDAS)..... **31.50**
- Canon Battery Adapter Plate for Micro Pro (LILPMPDAC)..... **36.00**
- Panasonic Battery Adapter Plate for Micro Pro (LILPMPDAP)..... **36.00**
- Sony Battery Adapter Plate for Micro Pro (LILPMPDAS)..... **36.00**

**Croma On-Camera LED Light**

Produces a shadowless soft light at variable color temperatures adjustable by a dial on the side of the panel. Color can be selected from 3200K tungsten to 5600K daylight, and brightness can be tweaked via smooth 0-100% dimmer dial. (LICROMA)..... **584.10**



**SolaENG 3" LED Fresnel**

Provides the beam control, illumination, and single-shadow properties of a Fresnel fixture at a fraction of the required power. Fully dimmable, this cool-to-the-touch on-camera LED is flicker-free and requires only 30w of power to produce the tungsten equivalent of 250w. (LISENG)..... **715.50**



**MiniPlus 25 Watt On-Camera Light Kits**



MiniPlus is a heavy-duty, compact, portable, dimmable LED soft light. Mount on a camera, wall, or any place that calls for a highly portable softlight. Provides absolutely flicker free

- 5600°K and minimal color shift when dimming. Kits include Mini-Plus, rechargeable battery, power cable, 110 - 240v AC adapter/charger, filters and hard case.
- Tungsten 3200K Flood Kit (LIMPLCPK50T)..... **976.50**
- Daylight 5600K Flood Kit – No Case (LIMPLPK50)..... **684.00**
- Daylight 5600K Flood Kit (LIMPLCPK50)..... **976.50**
- Daylight 5600K Spot Kit (LIMPLPK30)..... **976.50**
- Tungsten 3200K LED Flood Light only (LIMPFTF)..... **598.50**
- Daylight 5600K LED Flood Light only (LIMPFDL)..... **598.50**
- Daylight 5600K LED Spot Light only (LIMPFDL)..... **598.50**

**MiniPlus Accessories**

- MiniPlus 2-Pin D-Tap Power Cable (LIABP)..... **56.70**
- "Baby" Pin (1/4-20) light stand stud adapter (LIBPA)..... **13.50**
- Panasonic DV battery adapter plate (LIDVAPP)..... **89.10**
- Canon DV battery adapter plate (LIDVAPC)..... **89.10**
- Sony "L" and "M" battery adapter plate (LIDVAPS)..... **89.10**
- 2-inch Jumper Cable (LIPAJ) or 10' Extension Cable (LIPAG)..... **9.00**
- 100-240v AC Adapter/Charger with Int'l Plug Set (LIPWR)..... **58.50**
- MDVAP-P DV Adapter Plate for Panasonic (LILPMDAP)..... **31.50**
- AC Power Supply for Micro and MicroPro (LIPMMP)..... **31.50**
- 12v Rechargeable NiMH Battery (LILPB)..... **170.10**

**Ringlite Mini Soft,**

Wrapping, HD Talent Light

At home on or off camera, mounted on a stand, the wall, or elsewhere, the Ringlite Mini delivers luxurious levels of luminous soft, directional output in a cost-effective, versatile package. (LIRMP)..... **2065.50**



**i-Light • iD-Light**

12/14v 55 or 100-watt DC Focusing Lights

The battery-powered i-Light and iD-Light provide fill light, eye-light, highlights, and contrast control in news and documentary shooting, without overwhelming available light. Ideal for on-camera use, 6:1 focusing range lets you change lamp position from flood to spot or anywhere in between. Otherwise identical, the iD-Light has a built-in 20 kHz dimmer to provide graceful, flicker-free dimming.



- i-Light with Anton Bauer Tap (LOI045)..... **155.99**
- i-Light with 4-pin XLR plug (LOI02)..... **149.95**
- iD Light with Anton Bauer Tap (LOID045)..... **255.00**
- iD Light with cigarette plug (LOID01)..... **262.99**
- iD Light with XLR plug (LOID02)..... **262.99**

**Pro-Light**

12v/30v/120v, 50-250w AC/DC Focusing Light

Looks like the i-Light, but adds 30v DC and 120v AC capability. Small and focusable, the Pro-Light is more efficient than a mini-fresnel of equal wattage, yet it gives an exquisite even light, with fresnel like shadow quality, evenly dispersed flood, and a uniform spot with significant barndoor cut. To use as an on-camera light, simply add a DC adapter cable and swappthe bulb.



- Pro-Light (120-230VAC/12-30VDC) (LOPLA)..... **127.95**
- Pro-Light (230VAC) (LOPLX)..... **119.99**

**Blender 120-240V/12VDC LED Light**

Makes it possible to fine-tune your lights to match (or contrast with) whatever light you're grappling with. With twin arrays of daylight and tungsten LEDs in one fixture, two simple dials make it possible to dial in the light to exactly the color you choose (from 2800°K to 6000°K). This tiny unit (1.2 lbs and small enough to hold with a pistol grip) puts out a solid 56W of light, and is dimmable from 100% to 10%. Runs on included AC adapter, or an optional camcorder battery sled (Panasonic, Sony or Canon). Also includes front safety plastic and three front diffusers. (LOBLN10)..... **494.00**



**Manfrotto ML360H**

Midi-36 Hybrid LED Panel

As a Hybrid LED light, the ML360H has a flash setting, triggered by a sync cable, that emits a pulse of light 4x brighter than the maximum continuous light it can produce. When used as a continuous light source, 36 LEDs emit a constant 5600°K (daylight), with an illuminance of 420 LUX at a distance of 1m. Its infinitely variable dimmer allows precise control over light output and exposure. Can be hand-held, fitted to supports via 1/4" thread or mounted on a flash shoe—horizontally or vertically thanks to its two shoe attachments. #MAML360H..... **114.97**



**PAG**

- Snap-On to V-Mount Adaptor (PA9510)..... **191.95**
- PAGlink PL96e 14.8V V-Mount Li-Ion Battery (PAL96E3)..... **537.95**

**Polaroid**

- Swivel & Bounce 256 LED Video Light (POPLED256)..... **189.95**
- LED Video Light Panel (POPLED54)..... **79.95**

800-947-1186 | 212-444-6686



**RL48-B LED RingLight Stealth Edition**

- 80W equivalent for camcorders, DSLRs
- 4 hour run-time with 3x AA batteries
- 6 oz and weather resistant
- Slides onto shotgun mic
- 48 ultra-bright Grade-A LEDs, dimmable over 1.5 stops



#RORL48BS (with comprehensive filter kit) ..... **129.99**

**Creative Color Kit V2:** Includes Rotolight RL48-B, Rotolight Stand, Color FX Filter Kit and Pouch (ROCKV2)..... **199.99**  
 Rotolight Stand (RORL48STAND)..... **58.99**  
 Add-On Color Filter Pack (10 filters) (RORL48CFP)..... **Log-on**  
 Male 1/4" to 1/4" Adapter Stud (RORL1414) ..... **12.50**  
 Male 1/4" to 3/8" Adapter Stud (RORL1438) ..... **7.50**  
 Female 3/8" to Male 1/4" Adapter Stud (RORL3814)..... **7.50**  
 RL48-360 Ball Swivel to 1/4"-20 Adapter (RORL48360) ..... **21.99**  
 Superclamp (RORLSC)..... **34.99**  
 Video Accessory Pouch (RORL48ABP)..... **Log-on**

**sachtler Reporter LED H**

On-Camera Light

Compact, energy efficient, and highly robust dimmable, tungsten-balanced LED light. With its tough, waterproof housing and single LED module that can be swapped out for either daylight or tungsten, the LED H allows an input voltage of 6 to 24v DC, making it a great match for everything from a small 7.2V HDV camcorder to a large studio or ENG broadcast camera. Includes 4-leaf barndoors, and a removable reflector that further focuses the light. (SARLEDDT)..... **298.50**



**Seculine L2S5K On-Camera LED Light**

Delivers dependable on-camera lighting in a lightweight package. Attached using the included mini ballhead and 1/4" screw mount, this daylight-balanced (5600K) light has a built-in dimmer that can vary the light output from 0 to 100% in 30 steps, and a built-in fan that can be controlled with 5-step manual control. Light module is interchangeable with optional 3200K module for easy switching between daylight and tungsten light. (SELUDMBC)..... **399.00**  
 With Tungsten & Daylight Light Modules (SELUDMBC)..... **570.00**



**SV SV-840K**

On-Camera AC/DC Light Kit



- Tilt function for ceiling bounce
- Comes standard with 4 leaf barn door, 5600K dichroic filter and 100w 12v DC lamp
- Includes universal shoe, 12v DC battery and charger, 4-pin XLR cable and XLR plug to AC cord.

#SMSV840K..... **179.00**

**Cool-Lux**

LC-7150 500 Watt AC Photo Dimmer (COLC7150)..... **21.95**  
 MD-5150 Scissor-Clamp (T-Bar) Light Mount (COMD5150)..... **15.95**  
 MD-5250 Original Spring Clamp Light Mount (COMD5250) ... **19.95**  
 MD-5300 Light and Umbrella Mount (COMD5300)..... **22.95**

**Xtender**

CSR-10 Shoe Receiver (XTCSR10)..... **38.95**  
 SFRC-10-1 Single Rod Clamp (XTSFRC101)..... **68.95**



**STL-3000 Professional On-Camera Video Light**

Puts out 900 lumens of bright LED light from the top of your camera. The included L bracket mounts to a camera's cold shoe, and the angle of the bracket is adjustable. This combined with the dimmer, makes it suitable for a variety of shooting situations. (STL3000)..... **199.99**  
 STL-VariColor 320 On-Camera LED Light (STLVARIC320)..... **249.00**



**witronix XP-L90**

90WH 14.4v Lithium-Ion Batteries  
 Features 2-pin output connectors, power gauge and information storage.  
 #SWXPL90S (Sony V-Mount)..... **417.50**  
 #SWXPL90A (Anton Bauer Mount) ..... **417.50**  
 #SWXPL130S (XP-L130S 130WH Battery)..... **349.95**  
 XP-L95RED V-Mount Battery f/RED ONE (SWXPL95RED) ..... **377.95**  
 V-Mount Plate for Sony F3 (SWGPS2PTX)..... **199.95**  
 V-Mount Plate for EPIC / Scarlet (SWGPSEPIC10)..... **299.95**  
**NP-50:** 13.2v 50WH NiMH NP-1 Style Battery (SWNP50)..... **129.95**  
**NP-L60:** NP-1 Style Li-Ion Battery (SWNP60)..... **166.95**



**TL-BT200 TorchLED Bolt**

200w On-Camera Dimmable LED Light

16-LED light is powerful enough to use as a fill light outdoors. Features a brightness and throw (40-50') that put it in the range of halogen lights. Two knobs for controlling the 5-100% dimming of 3000K light and 6000K light.  
 #SWTLBT200 ..... **379.95**  
 Bolt Battery Kit (SWTLBTK)..... **79.95**  
**TL-50 TorchLED** 30w LED Light (SWTL50)..... **149.95**  
 Battery Pack for TL-50 (SWTLB11)..... **60.00**



**GP-H56**

DV/HDV On-Camera LED Light  
 Draws only 16w while producing the equivalent of 100W of daylight-balanced light. Frosted and CTO pop-in gels and a focusing lens to convert the beam from 115° to 45° are built in to the light.  
 #SWGPH56S (uses Sony L series batteries)..... **248.95**  
 #SWGPH56P (uses Panasonic CGR series batteries)..... **219.00**



**Power Supplies and Power Cables**

20" Powertap Cable for Canon (SWXPDVC20)..... **109.95**  
 20" Powertap Cable for C300 (SWXPDVC30020)..... **119.74**  
 20" adapter cable for Sony (SWXPDVS20)..... **112.95**  
 24" P-tap cable for Marshall LCD50 (SWXPMAR8)..... **119.95**  
 28" PowerTap to open-end cable (SWPTCABLE)..... **23.50**  
 28" PowerTap to 4-pin XLR cable (SWPTXLR)..... **34.95**  
 36" PowerTap Extensino Cable (SWTPTMPTFCABL)..... **41.95**  
 48" Power Cable for Canon DSLRS (SWXPDVCH)..... **150.00**  
 Powertap BlackMagic 24" converter cable (SWXPMAGIC12)..... **149.00**  
 Dual P-Tap V-Mount Plate for Cinema (SWGPSBMCC) ..... **182.50**  
 PowerTap male to female and 4-pin XLR-F (SWPTXF3) ..... **39.00**  
 V-Mount hot swap adapter (SWGPTS)..... **159.95**  
 V-Mount plate with PowerTap port (SWGPS)..... **79.95**  
 SPU-4 Compact power supply (SWSPU4)..... **90.00**  
 GP-2LAJ 2-position charger for A/B (SWGP2LAJ) ..... **375.00**  
 GP-2LSJ 2-position charger for V-mount (SWGP2LSJ) ..... **375.00**  
 PowerBase 70 (Battery Pack Only) (SWPB70B)..... **245.95**  
 PowerBase 70 for Panasonic AG-AF100 (SWPB70VBG)..... **299.00**  
 PB70C PowerBase Charger (SWPB70C) ..... **44.95**  
 Powerbase-70 for Blackmagic Cinema (SWPB70BMCC) ..... **299.95**  
 Powerbase-70 Contact Block for Cinema (SWGPDVBMCC)..... **89.95**

**SERIES7**

**SL-50 7.2V 7000mAh Lithium-Ion Battery**

Power a 7.2v camcorder for up to 50% longer. Features 4-stage LED readout with temperature and fuse protection. Optional plates allow use on different cameras. (SESL50) ..... **78.00**  
 Adapter Plates for Sony (SES7SHD) ..... **29.95**  
**BCL-1:** Quick Charger for SL-50 Batteries (SEBCL1), **118.95**



**EX-L96 96WH 14.4v Lithium-Ion Battery**

50% longer runtimes for the PMW-EX1 and PMW-EX3. Features 4-LED remaining power gauge and on-board PowerTap for powering 12v accessories such as lights or monitors). #SEEXL96..... **Call**

**VariZoom**

Lithium-Ion & NiMH Batteries and Charger

**S8056N:** NP-1 style 56WH lithium-ion battery with 4-level LED power indicator. Intelligent control circuit for temperature, current and voltage protection. VAS8056N ..... **159.95**

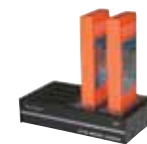

**SC-302:** Multi-chemistry dual-bay sequential charger for NP-1 style Nicad, NiMH, and lithium-ion batteries. #VASC302..... **164.95**

**S-8080A 14.4 VDC Lithium Ion Battery**

88WH V-mount on camera battery with 4-level digital LED readout. #VAS8080A..... **198.50**  
 4-Pin XLR to D-Tap Adapter Cable (VAS7101) **28.49**  
 S7000S Camcorder Battery Plate (VAS7000S) ..... **66.49**



**Vidpro Z-96K**

Video and Photo LED Light

With 96 high intensity LEDs, the light can offer bright illumination by producing a powerful light beam. Using the adjustable stepless dimmer, you can control the brightness in the range of 0-100%. You can select different color temperatures (5600-4200K-3200K) using filters. Magnetic mounting system allows quick and secure filter/diffuser usage. Interlocking housing design supports creation of stackable multi-unit LED array. (VIZ96K) ..... **164.52**  
 Varicolor LED Light Package, 8 pack (VLED144) ..... **149.00**  
 Varicolor LED Light Package, 9 pack (VLED312) ..... **199.00**  
 K-120 On-Camera LED Video Light Kit (V/K120) ..... **119.99**  
 Z-96K4 Professional LED Light Kit (VIZ96K4)..... **579.00**  
 AC Adapter for Z-96 LED Light Kit (VIZ96AC)..... **19.95**



**Z90 LED ENG Kit**

The Z90 head packs 230 Hi-LEDs into a square inch panel which produces a remarkably soft 60° beam. Instantly change between fully calibrated Tungsten and Daylight white light with the push of a button. Gel Mode gives you over 400 industry-standard theatrical gel numbers. #ZYZ90ENGK..... **1149.95**  
 Z90 D-Tap Battery Cable (ZYCZ90)..... **61.90**



## DELV CAM

## DELV-MLCD25

2.5" Color LCD Monitor

2.5" (480 x 234) display so tiny, it comes with a wrist strap. Ideal for confidence-monitoring. Composite video input (NTSC/PAL) plus included T-cable feeds a second monitor via its loop output. Has a built-in Li-ion battery, and comes with an AC adapter /battery charger. (DELVMLCD25).....



159.95

## EN200 5.6" LCD Monitor

5.6" (480 x 234) LCD monitor with RCA composite video and audio inputs and headphone output. Screen reverse switch displays image upside down, great for ceiling mounting in vehicles. Controls include volume, color, contrast, and brightness



#DEEVFEN200 ..... 199.95

## Marshall

## V-LCD4L-PRO-L

4" LCD Monitor

- View in both color or B&W
- Switchable dual video BNC inputs
- Wide viewing angle
- Color, contrast, and brightness control



#MAVLCD4PROL ..... 229.95

#MAVLCD4PROLK (with battery, charger and case) ..... 281.75

## V-LCD50-HDMI

5" HDMI On-Camera Monitor

- 800 x 480 resolution • HDMI input
- High brightness and clarity
- Shoe mount adapter
- Front panel controls
- False Color Filter • Peaking filter
- Runs on included AC adapter or 4 AA batteries



#MAVLCD50HDMI ..... 479.00

#MAVH50 (5" Monitor Hood for the V-LCD50) ..... 19.54

## V-LCD5.6-PRO

5.6" Camera Mountable LCD Monitor

- Built-in speaker and reverse image capability.
- Can mount on top of even the smallest video cameras
- Audio and headphone input
- Built-in tilting stand



#MAVLCD56PRO ..... 251.85

## V-LCD51

5" Backlit-LED LCD Monitor

Features 800 x 480 resolution and 600:1 contrast ratio. Switch between full-screen, 4:3 and 16:9. Offers RGB Bias and Gain, RGB Check Field, Peaking mode, RGB Field Detect, Image Flip, Freeze Frame, host of markers, and three color temperature presets (5500K, 6500K, 9300K). Includes two chargers (one DC), hood, hot-shoe adapter, bracket with two hot shoes and power supply. With LP-E6 Battery and Adapter (MAVLCD51LPK).....



379.00

With NP-F970 Battery and Adapter (MAVLCD51SL) ..... 389.00

## ikan

## VL5 5" LCD WVGA (800 x 400) HDMI Monitor

Monochrome and Color Peaking features highlight the desired focus area in a bright, silver outline. Other features include Underscan, switchable aspect ratio & ratio guides, Blue Gun, RGB adjustable, native EOS-5D Live View output and 480i/p, 576i/p, 720p, 1080i/p input. Includes sun visor, shoemount, and BP5-E6 DV battery plate #IKVL5KITE6.....



224.00

## IndiPRO Tools Pro5

5" Monitor for DSLRs / Camcorders

Features 800 x 480 resolution, 600:1 contrast ratio, and HDMI input. Professional functions include monochrome and color peaking modes; adjustable RGB; Blue Gun mode, and Underscan. Native Canon 5D Live-View Output shows images in the 5D's aspect ratio, without stretching them. With Canon BP (INP5LDCBP) or LP-E6 (INP5LCDLPE6), Panasonic CGR (INP5LCDPCGR) or Sony Battery Plate (INP5LCDSL).....



## SONY CLM-V55 5" Clip-on LCD

- WVGA (800 x 480) resolution
- Color peaking and pixel magnification for precise focus confirmation
- Adjustable aspect ratio (16:9/4:3), color tone (phase), color temp
- Speaker and headphone jack
- Tilt/swivel for comfortable viewing at any angle
- On-screen markers aid precise framing



#SOCLMV55 ..... 398.00

#SOCLMV552B (w/NP-FM500H battery &amp; BC-VM10 charger)..... 498.00

## TTE VISION

## LCD-562

5.6" LCD Monitor

- 900 x 234 resolution
- NTSC/PAL switch
- Composite video and audio I/O
- AA battery box can hold 8 alkaline or 10 nicad batteries



#TOLCD562 ..... 271.00

HS-1 Hot Shoe Mount (TOHS1)..... 18.79

LCD-410 4" LCD Monitor (TOLCD410)..... 189.00

LCD-501 5" LCD Monitor (TOLCD501)..... 225.00

BP563 Rechargeable Battery Pack (TOBP563C)..... 74.00

## Marshall M-CT6

6.2" HDMI/VGA LCD Monitor

LED-backlit 800 x 480 monitor, 400 nits, 500:1 contrast ratio, headphone jack, rear speaker, HDMI input and a VGA port for connection to a PC. Features Auto Aspect Ratio Detect, Zoom, Image Flip and Flop, and full color adjustment. Battery saver switch lets you conserve battery power whenever possible. Includes Canon LP-E6 battery adapter and battery, two battery chargers (one a car charger), hot-shoe adapter, HDMI and AV cables, remote control, carrying pouch and a power supply. #MAMCT6CE6.....



359.95

## DELV CAM

## DELV-HD7

7" HDMI/VGA LCD Monitor

Features 800 x 480 resolution, 500:1 contrast ratio and brightness of 300cd/m<sup>2</sup>. With the automatic display adjustment, you can adjust settings like brightness, contrast, resolution, and color quality. Four adjustable backlight levels for daytime or night-time use. HDMI & VGA inputs, plus dual composite video and audio inputs. Works on 12v DC and comes with a 110/220 power adapter. Includes full-function IR remote control. #DEHD7.....



269.95

UltraMount Universal Ball Mount (DEUUBM)..... 13.95

Case with sunshade for 4-7" LCD monitors (DEMCS1)..... 19.95

Motorcycle Camera and Video Mount (DERAMB149ZC1)..... 26.95

## DSLR-7L On-Camera 7" HDMI LCD Monitor

High resolution, super bright monitor with HDMI loop-thru input and pixel-to-pixel mode. Can be powered via 12v DC or camcorder battery and includes a snap-on sun shade hood.



- One-touch front panel Peaking, Exposure, False Colors, DSLR ratio adjustment and Histogram functions. Also color bar, Underscan, H/V Delay, Freeze Input, Center Marker or Screen Marker. #DELVDSL7L (with DC adapter and Sony battery plate).....

399.95

## DELV-7XLPRO

7" 16x9 Color LCD Monitor with ATSC Tuner

Offering ultra bright, high resolution LCD technology, the monitor delivers amazing clarity and incredible wide angle peripheral viewing. Features 16:9 aspect ratio, 1440 x 234 resolution and NTSC/PAL auto signal detection.



- Integrated ATSC Tuner lets users monitor the off-air digital broadcasts in their area. Also cable ready from any CATV feed. #DE7XLPROA.....

249.00

## DELV-7XLPRO 7" 16:9 LCD Monitor Field Kit:

Includes the monitor, battery and charger, AC adapter, mounting bracket for a monopod /boom pole, strap, and a Cordura carrying case with fold-out flaps that attach via touch-tabs to the sides for viewing privacy, or shade the screen. (DE7FPWC).....

395.00



## DJ7HDPRO 7" LCD

Production Monitor Bundle

Compact and lightweight high-quality

HD/SD monitor with intuitive onscreen controls

and a risp

1024 x

600 resolution so your shots are sharp, perfectly framed, and in focus. Front panel switches for aspect ratio, mode/input, on-screen menu, image magnification.



- Onscreen controls for color temperature, Picture in Picture (PIP), screen markers, sound and much more
- HDMI input plus component and composite video/audio I/O
- Includes cables, sun shade, hotshoe ball head stand, NP-F type battery and charger. Also includes tally connection kit, neoprene monitor cover, and 11" articulating arm and mini clamp. #DIHDPRO7LCD.....

549.95

800-947-1186 | 212-444-6686

On-Camera Monitors



**SWIVI 5.6" LCD Monitor for DSLRs**

Attaches to a DSLR with an HDMI port and Live-View function via the tripod socket. The monitor swings out up to 180° and will tilt as much as 270° for superb flexibility in viewing your images. Features peaking mode, zoom in/out function and stereo speakers. Runs on Canon-type LP-E6 battery and includes a sunshade hood. (DOCSSWIV).....**349.00**



**JVC DT-X71C ProHD**

7" AC/DC Portable Monitor

- 1024 x 600 resolution, switchable 16:9 or 4:3, 900:1 contrast ratio, 400 cd/m2 brightness,
- Underscan/overscan switch, plus image can be rotated by 180°.
- HDMI, composite, stereo audio, and composite loop through out
- Two TALLY lights give "live" signals that shooting is going on.



#JVDTX71C.....**Log-on**  
 #JVDTX71H (7" AC/DC HDMI/HD-SDI LCD Monitor).....**Log-on**  
 #JVDTX71F (7" AC/DC HDMI/HD-SDI Waveform Monitor).....**Log-on**

**SONY**

**LPM-770BP 7" Active Matrix LCD Monitor**

- Color peaking function
- False color level indicator
- Native resolution function with 1:1 pixel mapping
- HDMI, component, and two composite inputs
- Powered via its 4-pin XLR plug or L-Series batteries



#SOLPM770BP.....**1049.95**



**HD071A2 7.1" HD Pro LCD Monitor**

- Resolution of 1024 x 600, but input is scalable up to 1080p.
  - Brightness of 400 nits, and 500:1 contrast ratio.
  - Three 1/4"-20 threaded inserts for multiple mounting options.
  - RGB color-temperature controls
  - Focus assist (peaking), false color, blue gun (blue only)
  - HDMI, HD component, SD composite, and analog VGA inputs
- #MAHD071A2 (with IR remote control).....**399.00**  
 HD089B2 8.9" HD Pro LCD Monitor (MAHD089B2).....**399.00**  
 SH089X2 Sunhood for the HD089B2 (MASH089X2).....**25.00**



**VariZoom VZ-TFT7**

7" LCD Monitor

Combined with a tripod-mounted camera and a VariZoom lens controller, the VZ-TFT-7 emulates a 16:9 studio-style rig costing thousands of dollars.



#VAVZTFT7 (VZ-TFT7 Monitor).....**278.49**  
 #VAVZTFT7U (with Battery, Case, Shoe Mount, Sun Hood).....**386.10**  
 Replacement Li-Ion Battery Pack (VAVZB72).....**39.99**  
 Sun Hood for VZ-TFT7 (VAVZHD7).....**18.95**

**ikan**

**VK7i 7" IPS LCD Monitor**

The VK7i employs an HD IPS (In-plane Switching) LCD panel, giving the monitor 1280 x 800 resolution, wider viewing angles and exceptional color rendition. Features on-screen tally, HDMI loop-through, RGB adjust, DSLR Scaling and Clip Guides. The VK7i is easy to power in the field with multiple battery plate options from DV battery, DSLR, or Pro battery.

- Monochrome and color peaking feature with a red highlight can help you achieve sharp in focus images every time.
- False Color feature utilizes a full spectrum of assigned color indicators, ensuring flawless shot exposure.



#IKVK7IE6 (with Canon E6 Battery Plate).....**449.00**

**VX7i 7" 3G-SDI LCD Monitor w/ IPS Panel**

1280 x 800 HD IPS LCD Panel, 3G HD-SDI, HDMI, composite and component inputs - all complimented with outputs with no signal loss and loop through capabilities. Tally system on the front and back. Front panel controls include two assignable function and input selection buttons, and knobs for aspect ratio, brightness, contrast, and chroma.

- Powered by DV Canon DSLR, or professional batteries that mount on the back. There are mounting holes for the plate that holds the V-mount or the Anton Bauer Pro batteries.



IKVX7IE6 (with Canon E6 Battery Plate).....**809.00**

**D7 • D7w**

7" 3G-SDI LCD Monitors w/ Hi-Def Panel

Sleek yet durable aluminum construction dissipates heat while protecting the monitor thus ensuring its reliability and longevity. 1280 x 800 IPS panel puts out vibrant colors and great viewing angles. The D7w steps-up with waveform, vectorscope and RGB parade.

- 1:1 pixel-to-pixel mapping • Monochrome and Color Peaking
- False Color feature • DSLR Scaling function
- Clip Guide levels to accurately display overexposed images

D7 with Sony L-Series Power Kit (IKD7K).....**989.10**  
 D7w with Sony L-Series Power Kit (IKD7WK).....**1169.00**



**MR7**

7" 3G-SDI Monitor w/ Built-in H.264 Recorder

Rugged 7" 1024 x 600 field monitor with built in H.264 recorder with 4GB of internal memory plus an SD slot. Housed in a durable construction with rubberized texture for a firm grip, the H.264 recorder has an "auto start/stop" feature that syncs the time code from your camera to the monitor's recording files.

- Supports 2K resolution
- HDMI-to-SDI conversion with 1:1 resolution mapping
- Waveform, vectorscope, RGB Parade, a test pattern generator, and audio VU meter. Audio level meter up to 1~16 channels
- Tally Display / Tally LED Control output

#IKMR7.....**2069.00**



**Marshall**

**M-CT7 7" Portable On-Camera Field Monitor**

- Up to 1920 (H) x 1440 (V)
- 2 composite video, HDMI, and VGA inputs
- Rear speaker for audio monitoring
- Auto Aspect Ratio Detect
- Image Flip / Flip
- Color Temperature Adjustment



With Canon BP511 battery (MAMCT7C511).....**359.95**  
 With Canon LP-E6 battery (MAMCT7CE6).....**359.95**  
 With Nikon EN-EL3E battery (MAMCT7NEL3).....**359.95**  
 Sun Hood for M-CT7 (MAMSUN702).....**18.39**  
 Sun Hood for M-LCD7-HDMI (MAMSUN701).....**18.39**  
 Sun Hood for 7" V-LCD Series (MAVH70X).....**19.54**  
 V-LCD70-ATSC 7" Field Monitor (MAVLCD70ATSC).....**201.25**

**V-LCD70XHB-HDMI**

7" Field / Camera-Top LCD Monitor

- 800 x 480 resolution
- 800cd/m² brightness
- 800:1 contrast ratio
- Optical grade polycarbonate scratch-proof protective screen
- False color filter/peaking filter
- Adjustable backlight and markers
- Composite, component and HDMI input
- Pixel-to-Pixel mode • RGB check field / field detect
- 4 User-programmable buttons • 4-pin XLR power jack



#MAHDMIPT.....**987.85**  
 With Canon (MAHDMIPTCM), Panasonic (MAHDMIPTPV), or Sony L battery mount (MAHDMIPTSL).....**1010.85**

**ikan vhs 8" HDMI Monitor with HD Panel**

Ultra wide 1600 x 768 HD LCD with H.U.D (Heads Up Display) vertically on the right side of the screen that reads incoming signals as well as false color and peaking. Ideal for on camera fieldwork as well as mounted on a stand for studio use. Features four customizable touch sensitive function buttons, HDMI I/O and composite outputs.

- DSLR Scaling, Underscan, Movable Pixel to Pixel
- Guides (4:3 & 16:9 Framing Safe Area)
- Check Field (blue, red, green, monochrome)

#IKVH8E6 (with Canon E6 Battery Plate).....**359.00**



**Sun Shades for Ikan LCD Monitors**

SH56 Sun Hood for V5600 LCD (IKSH56).....**33.49**  
 SH8 Sun Hood for V8000 (IKSH8).....**31.36**  
 SHX7 Sunhood for the VX7/VX7e (IKSHX7).....**38.49**  
 SHX7-V Sunhood for VH7e and VL7 (IKSHX7V).....**17.86**  
 SHX9 Sunhood for the VX9/VX9e (IKSHX9).....**40.36**

**Power Accessories for Ikan LCD Monitors**

BP2-E6 Battery Plate for Canon 5D/7D Battery (IKBP2E6).....**24.95**  
 BP5-C DV Battery Plate (IKBP5C).....**17.86**  
 BP5-E6 (IKBP5E6), BP5-S Battery Plate for VL5 (IKBP5S).....**19.00**  
 Panasonic (IKBP2TP), Sony (IKBP2TS) or Canon DV Battery Plate for VH7 (IKBP2TC).....**26.86**  
 Panasonic DV Battery Plate for VX9 (IKBP2P).....**26.86**  
 Sony DV Battery Plate for VX9 (IKBP2S).....**27.99**  
 Sony Battery Adapter Plate for "L" Series (IKAC107S).....**62.86**  
 Canon Battery adapter for the V5600/V7000 (IKAC107C).....**62.86**  
 BP5-P DV Battery Plate for VK7/VH8 Monitors (IKBP5P).....**17.86**  
 Anton Bauer Mounting Plate (IKMA).....**59.95**  
 IBP-D54 Battery for Panasonic Cameras (IKIBPD54).....**62.86**

## ikan

### VX9e 8.9" HD-SDI LCD Monitor

Equipped with Monochrome/Color Peaking for sharp lines and stark contrasts the VX9e (1024 x 768) gives you optimal focus control. With the False Color feature, the VX9e offers a full spectrum of assigned color indicators to ensure flawless shot exposure.



- HD-SDI (which also converts the signal to analog component out), HDMI, HD/SD component, S-Video, and composite inputs,
  - Adjustable under/over exposure and over exposed warning
  - Underscan, H/V delay, Blue gun – monochrome
  - Aspect ratio (Full / 16:9 / 4:3) • Side-by-side freeze frame
- With Canon 900 (IKVX9EC), E6 (IKVX9EE6), Panasonic (IKVX9EP), Sony BP-U (IKVX9ESU) or Sony battery plate (IKVX9ES)..... **809.00**  
 VX9e Deluxe Kit with Sony L Series battery (IKVX9ESDK)..... **949.95**

## Marshall MD Series

5.6,-7- and 9" Monitors

with Modular I/O

Feature a wide variety of formats and markers, 4 user-configurable front panel function buttons, RGB gain and bias control, backlight control and RGB Check Field / Field Detect. Also offer icon driven menu system, Waveform display with dual audio bars, headphone output, and variable pixel-to-pixel function.



- 5.6" Base unit only —no module (MAVLCD56MD)..... **799.00**
- 5.6" with 3G/HD/SD-SDI input module (MAVLCD56MD3G)..... **999.00**
- 5.6" with 3G/HD/SD-SDI output module (MAVLCD56MD3O)..... **999.00**
- 7" Base unit only —no module (MAVLCD70MD)..... **790.00**
- 7" with 3G/HD/SD-SDI input module (MAVLCD70MD3G)..... **999.00**
- 9" Base unit only —no module (MAVLCD90MD)..... **1399.00**
- 9" with 3G/HD/SD-SDI input module (MAVLCD90MD3G)..... **1599.00**
- Sun Hood for V-LCD56MD 5.6" Monitor (MAVH56MD)..... **18.99**
- Sun Hood for V-LCD70MD 7" Monitor (MAVH70MD)..... **18.99**
- Sun Hood for V-LCD90MD 9" Monitor (MAVH90MD)..... **18.99**

### Power Accessories for Marshall LCD Monitors

- Battery Plate for Canon BP-970G (MABBP970G),
- Panasonic CGA-D54 (MABPCGAD54), Sony NP-F970 (MABPNF970) or Sony BP-U60 (MABPBU60)..... **22.94**
- 4-Pin XLR Power to A/B Power Tap (MAVPACDXLR)..... **40.25**
- VBP-12LCD Battery with Charger (MAVBPT12LCD)..... **56.35**
- V-Mount to A/B Battery Adapter (MAVABA01)..... **171.35**
- 12v AC (500ma) Power Supply (MAVPS12500)..... **11.39**
- 12v DC, 1 Amp Regulated Power (MAVPS121000)..... **16.09**
- V-BR5-LPE6 Battery Adapter (MAVBR5LPE6)..... **29.95**
- V-BR5-SL Battery Adapter (MAVBR5SL)..... **29.95**
- M-SC7 Case for 7" Monitors (MAMSC7)..... **48.00**
- AB Battery Mount (MA00321302A)..... **79.99**
- Battery Plate (MABPYVVBGG)..... **22.94**
- V-PA5V-2.0-US Power Supply (MAVPA5V20US)..... **17.25**
- IDX V-Mount Battery Adapter Plate (MA00321301A)..... **79.99**
- Battery Plate for Canon LP-E6-Type Batteries (MADSLRCL)..... **23.99**

## VELLO Vello Rigion

9" HD Camera Monitor

- 1024 x 600 backlit TFT display
- S-Video, component, HDMI, AV, VGA and VGA audio inputs
- Dedicated shutter release
- Includes remote, battery, shade, cable releases and AC adapter/charger (VECM9HD)..... **599.95**



## ON CAMERA LCD MONITOR MOUNTS & MOUNTING ARMS

### Noga

DG1108CA Cine Arm with 1/4" 20 Screw (NODG1108CA).....	<b>129.95</b>
MG6145CA Cine Arm (NOMG6145CA).....	<b>140.00</b>
DG6145CA Cine Arm (NODG6145CA).....	<b>119.95</b>
DG14CA-SA Cine Arm with Hot Shoe (NODG14CASA).....	<b>169.00</b>
NF Cine Arm 3/8" and Cine Lock Kit 1 (NONF38CACL1).....	<b>174.95</b>
NF1108CA Cine Arm (NONF1108CA).....	<b>126.00</b>
NF6145CA Cine Arm (NONF6145CA).....	<b>109.95</b>
DG14CA-CL1 Hold-it Cine Arm Kit (NODG14CACL1).....	<b>169.00</b>
Cine Arm & Cine Lock Kit 2 (NONF14CACL2).....	<b>239.95</b>
NF14CA-SA Cine Arm & Slide Shoe Kit (NONF14CASA).....	<b>174.95</b>

### Zacuto

Zamerican Articulating Arm V3 Small (ZAZARMS3).....	<b>185.25</b>
Zamerican Articulating Arm V3 Medium (ZAZARM3).....	<b>194.75</b>
Zamerican Articulating Arm V3 Large (ZAZARML3).....	<b>204.25</b>
Hotshoe Ball Mount (ZAZHSBM).....	<b>45.60</b>

<b>16x9 Inc.</b> Cine Lock QR Mounting Bracket (16CL01).....	<b>81.00</b>
<b>CPM Camera</b> 4" Articulated Arm with Rod Mount (CPA44).....	<b>49.95</b>
<b>CPM Camera</b> 8" Articulated Arm with Rod Mount (CPA48).....	<b>69.95</b>
<b>Delvcam</b> Delv-Flex Arm & Super Clamp (DEFLEXPRO56).....	<b>71.40</b>
<b>Digital Juice</b> Articulating Arm (DIAASMA).....	<b>46.95</b>



<b>Flolight</b> 11" Articulated Mounting Arm (FLARM11).....	<b>55.00</b>
<b>Manfrotto</b> Video Monitor Tray (MA311).....	<b>50.38</b>
<b>Manfrotto</b> 3/8" Mounting Plate w/ Lock Screws (MA208).....	<b>Log-on</b>
<b>Manfrotto</b> 3/8" Mounting Plate w/ Hex Stud (MA208HEX).....	<b>Log-on</b>
<b>Marshall</b> Tripod Mount Brackets (3) (MAVLC70TMB0).....	<b>22.94</b>
<b>Matthews</b> Mount for Baby (5/8") Spigot (MAMMLS).....	<b>184.75</b>
<b>Pearstone</b> 4.2" Articulating Israeli Arm (PEAA42).....	<b>34.95</b>
<b>Pearstone</b> 8.3" Articulating Israeli Arm (PEAA83).....	<b>39.95</b>
<b>Redrock Micro</b> 1.5" Micro Arm Short (RE20540004).....	<b>49.00</b>
<b>Redrock Micro</b> 4" Micro Arm Long (RE20540002).....	<b>64.50</b>
<b>RotoLight</b> 6" Articulated Magic Arm (RORLARM6).....	<b>Log-on</b>
<b>RotoLight</b> 6" Articulated Arm Kit (RORLARM6K).....	<b>99.99</b>
<b>RotoLight</b> 10" Articulated Magic Arm (RORLARM10).....	<b>99.99</b>
<b>RotoLight</b> 10" Arm & Clamp Kit (RORLARM10KIT).....	<b>129.99</b>

## HOODMAN LCD Hoods

Contoured Wrap-Around Viewfinder Hood

Hoodman H Series provides glare-free viewing of your LCD screen even in bright outdoor light. Made of plastic inserts wrapped in water resistant nylon, elastic straps are used to mount hoods to cameras. Hoods fold for quick and easy storage.



For 3" screens (HOHD300V).....	<b>Call or Log-on</b>
For 3.5" screens (HOH400).....	<b>Call or Log-on</b>
Hi-Def 16 x 9 LCD Camcorder Hood (HOHD350).....	<b>24.99</b>
For 4" screens (HOHD450).....	<b>24.99</b>
7" Monitor Hood for RED Cameras (HOHR7).....	<b>59.99</b>
For 6" LCD Monitors (HOH600).....	<b>39.95</b>
Short Hood for 8.4" LCD Monitors (HOH900S).....	<b>84.95</b>
Long Hood for 8.4" LCD Monitors (HOH900).....	<b>Call or Log-on</b>

## PETROL BAGS Mini Hood

Two-piece monitor hood reduces glare especially in bright sunlight. Made of light-weight padded fabric with rigid internal panels. Mini Hoods can be positioned 90° or 180° on the monitor. For camcorders with 2.5" diameter LCD (PEPA1007)..... **21.06**  
 For camcorders with 3.5" diameter LCD (PEPA1009)..... **21.06**



## Raider i-cuffs

Viewfinder Hoods

Attach securely to your viewfinder via a touch fastener for positioning and fit. Ultrasuede chamois fabric is waterproof and is crafted to the highest standards of durability and comfort (will still look new after 100,000 rubs).

#RAICUFFDV (fits viewfinders up to 5.5").....	<b>39.95</b>
#RAICUFF (fits viewfinders up to 9.5").....	<b>44.95</b>
#RAICUFFHD (fits viewfinders up to 10.5").....	<b>49.95</b>



## Garfield Hush Heels

Noise-Suppressing Foam Heelpads for Footwear (GAHH)..... **26.55**



## Mark Vb

Director's Viewfinder

Smooth 12x zoom ring. Focal lengths viewed in windowson viewfinder barrel.

Adjustable aspect ratio ring (1.33:1,

16x9, 1.85:1, 2:40:1 anamorphic). 6 glass elements for sharpest possible image. Color coded film sizes and video formats. Adjustable focus ring and rubber eyecup.



#ALDVFMB5.....	<b>659.95</b>
#ALDVFMB (Mini Director's Viewfinder).....	<b>142.95</b>
#ALRENV (Replacement Eyecup for Mark Vb).....	<b>5.50</b>
#ALWAA (Wide Angle Attachment for Mark Vb).....	<b>124.95</b>

**Blue Ring Gaffer's Glass:** Pocket-sized lens gives you a clearer picture as to where light will be thrown. Can also reveal the location of the sun behind clouds. (ALBRGG)..... **49.95**

<b>Birms &amp; Sawyer</b> Director's Micro Viewfinder (BIMVFQ).....	<b>194.95</b>
<b>Delta 1</b> Director's Hi-Chair (DEHCD).....	<b>211.95</b>



## VFM-11X Micro Director's Viewfinders

Covers focal lengths from 8mm to 80mm for 1" and 2/3" chip SD and HD cameras, 16mm focal lengths of 8.5mm to 94mm, and 35mm focal lengths of 18mm to 200mm. Aspect ratios are 1.33 (TV), 1.66, 1.78 (HDTV), 1.85 and 2.35.

#CADVFMZQ.....	<b>169.95</b>
----------------	---------------



## VDL-11X 11x Large Rotating Viewfinder

Professional yet affordable director's viewfinder that covers just about any film and TV format. Full range of focal length and aspect ratio adjustments.

#CAVDL11X.....	<b>378.95</b>
#CAVDM11X (11x Micro Director's Viewfinder).....	<b>228.95</b>



800-947-1186 | 212-444-6686



- 2.7" LCD Hood (VELHV27)..... **14.95**
- 3.0" LCD Hood (VELHV30)..... **18.50**
- 3.5" LCD Hood (VELHV35)..... **18.50**



- Camtrol 3" LCD Camshade (CALC3)..... **18.95**
- Camtrol 3.5" LCD Camshade (CALC35)..... **19.95**



**Oval Eye Cushions**

High-quality view-

finder eye cushion covers for professional video camera viewfinders. Provide thick, cushioned comfort and absorbency.

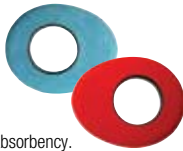

- Red Fleece Oval Small (BL90148), Large (BL90138)
- Red Fleece Round (BL20132), Blue Fleece / Large (BL90139), Red Microfiber Large (BL90132), Small (BL90142), X-Small (BL20102) Red Microfiber Long (BL90122)
- Blue Microfiber Large (BL90133), Small (BL90143), Round (BL20143), Chamois Small (BL90141), Large (BL90131), Long (BL90121), Chamois / Round X-Small (BL20101), Small (BL20141), Large (BL20131), X-Large (BL20121)..... ea. **5.45**
- Birns & Sawyer** Oval Chamois Eyepiece Cover (BIOEC)..... **5.95**
- Birns & Sawyer** XL Oval Chamois Eyepiece Cover (BIXLOEC)..... **6.95**



**Test Charts**

- Pocket CamFocus Test Chart (DSPCF)..... **69.95**
- Handy CamFocus Test Chart (DSHCF)..... **74.95**
- PCE Pocket Camette Test Chart (DSPCE)..... **99.95**
- 5-Step Grayscale, 6 Primary Colors, CamWhite (DSHCE)..... **154.95**
- FrontBox 12+4 Test Chart (DSFB12P4)..... **374.95**



**WarmCards White Balance Reference System**

Set of white balance cards that make it easy to get a warmer (or cooler) white balance, then keep the modified white balance consistent throughout the shoot – with precision.



- WarmCards 3.0 White Balance System (VOWC3)..... **89.95**
- WarmCards 3.0 Junior White Balance System (VOWC3JR)..... **49.95**

**Production Slates**

These versatile, dry-erase production slates (clappers) help sync your sound and identify shots on sets and production locations.



- Alan Gordon Enterprises**
- 11 x 9" Color Combo Scene Slate (ALCCSP)..... **65.95**
- 12 x 9.25" Engraved Combo Slate (ALCS119)..... **64.95**

- Birns & Sawyer**
- Economy Dry Erase Production Slate (BIDES)..... **29.50**
- Insert Slate without Clapper Sticks (BIS)..... **19.50**
- Slate with Color Clapper Sticks (BISACC)..... **94.95**
- Acrylic Production Insert Slate (BISAICC)..... **74.95**
- Chalkboard Production Slate (BISCBWC)..... **49.50**

- Pearstone**
- Erase Clapboard with B&W Sticks (PESADB711)..... **44.95**
- Erase Clapboard with Color Sticks (PESADC711)..... **49.99**
- Erase Clapboard with Color Sticks (PESADC7562)..... **29.95**
- Erase Clapboard with Color Sticks (PESADC911)..... **29.95**
- Acrylic Slate Inset (PESA15334)..... **7.95**
- Wooden Chalk Clapper (PESWC7363)..... **14.95**

- Cavision** Production Slate w/Clapper Sticks (CASSN2819)..... **59.00**
- Ikan** 9x11" White Production Slate (IKPS01)..... **35.66**
- ikan** PS02 Laser Engraved Production Slate (IKPS02)..... **44.86**
- ikan** Tablet Production Slate (IKTS01)..... **75.47**



**Professional Lens Attachments**

- EXII 72mm 0.6x Wide Angle Adapter (169HDWA6X72)..... **249.00**
- EXII 0.6x W/A Adapter f/PMW-EX1/3 (169HDWA6XE)..... **249.00**
- EXII 46mm 0.7x W/A Converter (169HDWC7X46)..... **190.00**
- EXII 82mm 0.8x W/A Converter (169HDWC8X82)..... **399.00**
- EXII 0.8x W/A Converter f/PMW-EX1/3 (169HDWC8XE)..... **590.00**



- 0.6x W/A for AG-HPX170/AG-HMC150 (CE0HD-6WAAG)..... **398.95**
- 0.3x Ultra Fisheye for DSR-200A (CEDSFEWA00)..... **828.95**
- 0.6x Wide Angle for PMW-EX1/3 (CEHD06WAEX1)..... **309.00**
- 0.6x WA for HVR-Z7U/ HVR-S270U (CEHD06WAZ7U)..... **379.95**
- 1.6x HD Tele for PMW-EX1/3 (CEHD16TCX1)..... **769.95**
- 2.0x Tele for PMW-EX1/3 (CEHD20TCX1)..... **1049.95**
- 0.75x Wide Angle for PMW-EX1/3 (CEHD75CVEX3)..... **849.00**
- 0.75x W/A for HVR-Z7U/ HVR-S270U (CEHD75CVZ7U)..... **799.00**
- 0.55x Fisheye for PMW-EX1/3 (CEHDFESUEX1)..... **419.95**
- Xtreme Fisheye Adapter Lens (CEHDFEWAAAG)..... **2699.00**
- 4x4 Sunshade/Filter Holder (CEVSS05)..... **126.10**



**Professional Video Lenses & Accessories**

**16x9 Inc.**

- PL to Sony E Cine Lens Mount (169CLMPLE)..... **499.95**
- PL to Sony E Cine Lens Mount w/bracket (169CLMPLES)..... **786.50**
- 110mm Rubber Lens Shade (169HU110S)..... **150.00**
- 110mm Rubber Lens Shade (169HU110L)..... **150.00**

**Fujinon**

- XA17x7.6BERM 17x 2/3" P2HD lens (FUJA17X76BER)..... **9999.95**
- 17x7.6BRM 17x 2/3" P2HD lens (FUJA17X76BRM)..... **7632.50**
- XS8X4AS-XB8 8x for Sony PMW-EX3 (FUXS8X4AS)..... **3899.95**
- XT17s45BRMK1 HD ENG lens (FUXT17S45BR)..... **Log-on**

**Cooke**

- miniS4/i Cine Lens Set (COPSET6)..... **46000.00**

**Sony**

- 11-16mm T3.0 Wide Angle Zoom Lens (SOSCLP11X15)..... **6999.95**
- SCL-Z18X140 for Sony PMW-F3 (SOSCLZ18X140)..... **9699.00**
- 3 Lens Kit PL Mount (SOSCLPK3F)..... **11,500.00**
- 6 Lens Kit PL Mount (SOSCLPK6F)..... **20,900.00**

**Porta Brace**

- LC-55X65 Medium Lens Cover (POLC55X65)..... **68.57**
- LC-6X8 Large Lens Cover (POLC6X8)..... **68.57**



**Compact Prime CP.2 Cine Lenses**

Compact Prime CP.2 lenses offer interchangeable mounts that allow the lenses to be used with a wide range of cameras. They also offer a wide choice of lenses. With precision and speed, the lenses are the perfect tool for independent filmmakers, still photographers or large studios using HD/SLR equipment as a second camera unit for TV and film productions.

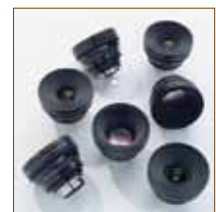

- 15mm/T2.9 EF Mount (ZCEP2T2915EF)..... **5700.00**
- 15mm/T2.9 PL Mount (ZCEP2T2915PF)..... **5700.00**
- 18mm T/3.6 EF Mount (ZCEP2T18T36EF)..... **3990.00**
- 18mm T/3.6 PL Mount (ZCEP2T18T36PL)..... **3990.00**
- 21mm/T2.9 EF Mount (ZCEP2T2921EF)..... **3990.00**
- 21mm/T2.9 PL Mount (ZCEP2T2921PL)..... **3990.00**
- 25mm T2.1 EF Mount (ZCEP2T2125EF)..... **4500.00**
- 25mm T2.1 PL Mount (ZCEP2T2125PF)..... **4500.00**
- 28mm/T2.1 EF Mount (ZCEP2T2128EF)..... **3990.00**
- 28mm/T2.1 PL Mount (ZCEP2T2128PL)..... **3990.00**
- 35mm/T1.5 Super Speed EF Mount (ZCEP2T1535EF)..... **4900.00**
- 35mm/T1.5 Super Speed PL Mount (ZCEP2T1535PF)..... **4900.00**
- 35mm/T2.1 EF Mount (ZCEP2T2135EF)..... **3990.00**
- 35mm/T2.1 PL Mount (ZCEP2T2135PL)..... **3990.00**
- 50mm/T1.5 Super Speed PL Mount (ZCEP2T1550PF)..... **4500.00**

- 50mm/T1.5 Super Speed EF Mount (ZCEP2T1550EF)..... **4500.00**
- 50mm/T2.1 Makro EF Mount (ZCEP250T21ME)..... **4900.00**
- 50mm/T2.1 EF Mount (ZCEP2T2150EF)..... **3990.00**
- 50mm/T2.1 PL Mount (ZCEP2T2150PL)..... **3990.00**
- 85mm/T2.1 EF Mount (ZCEP2T2185EF)..... **3990.00**
- 85mm/T2.1 PL Mount (ZCEP2T2185PL)..... **3990.00**
- 85mm/T1.5 Super Speed EF Mount (ZCEP2T1585EF)..... **4500.00**
- 85mm/T1.5 Super Speed PL Mount (ZCEP2T1585PF)..... **4500.00**
- 135mm/T2.1 EF Mount (ZCEP2T21135EF)..... **5700.00**
- 135mm/T2.1 PL Mount (ZCEP2T21135PL)..... **5700.00**
- 28-80/T2.9 EF Mount (ZCE2T2928EF)..... **19900.00**
- 28-80/T2.9 PL Mount (ZCE2T2928PF)..... **19900.00**
- 70-200/T2.9 EF Mount (ZCE2T2972EF)..... **19900.00**
- 70-200/T2.9 PL Mount (ZCE2T2972PF)..... **19900.00**
- Torx T6 Torque Wrench (ZETT6)..... **173.00**



**4 x 5.65" Matte Box**

Wide 16:9 hard shade matte box designed for use with a Cavision 5D Mark II shoulder mount rig. Offers 2 filter stages, expandable French flag, 85mm rubber adapter ring, and a bracket for attaching optional 15mm support rods.



- For Cavision 5D MII (CAMB41695DM2).....**405.90**
- 3x3" Matte Box with Top and Side Flags (CAMB3485S).....**208.95**
- Heavy Duty Clamp On Flag with arm (21mm) (CAMCF21).....**39.95**
- 6mm Thick 58 to 82mm Step-Up Ring (CAAR8258D6).....**10.00**
- 6mm Thick 72 to 82mm Step-Up Ring (CAAR8272D6).....**9.95**
- 6mm Thick 77 to 82mm Step-Up Ring (CAAR8277D6).....**10.00**
- 12mm Thick 77 to 82mm Step-Up Ring (CAAR8277D12).....**14.95**



**FM600 4x4 Matte Box**

This matte box features a French flag and 2 filter holders—one fixed, one that rotates 360°. Affixes to lens diameters of 43–82mm with the implementation of an optional Formatt threaded attachment adapter.



#FOMBFM600.....**220.97**



**Matte Box PRO**

Features adjustable top and side flags, two filter stages, two multi-

format filter holders, a swing-away mounting bracket and rubber lens donuts in four sizes. Filter stages can be rotated 360°.

The swing-away bracket facilitates quick access for lens changes, and the rubber lens donuts accommodate different lens diameters and prevent light leaks from behind the matte box.



#DIMBP.....**499.95**



**D/Matte Matte Box**

Designed with DSLR lenses in mind, features an 86mm lens opening, and includes an adjustable French flag, two 4 x 4 filter slots (one rotating), and an 86-82mm step down ring. For lenses smaller than 82mm, there are optional rings available.



#DFDM.....**240.00**  
82 to 52mm Step Down Ring (DFAR52).....**11.00**

**D/Matte Complete Matte Box**

Same as the standalone D/Matte Box but adds swing-away bracket for mounting 15mm rods and with French flags on both the top and sides. Use mounted on 15mm rods, clipped onto the lens of your camera as the D/Matte is a clip-on matte box first; or, for added support, you can have it mounted and clipped on at the same time (DFDMC).....**379.95**



**Chrosziel Matte Box Accessories**

- 104-77mm Step Down Adapter Ring (CH41109).....**73.00**
- 110-77mm Step Down Ring (CHSDR11077).....**89.00**
- Flexible Step-Down Ring (110:75-98mm) (CHSDR7598).....**94.00**
- Flexible Step-Down Ring (110:50-85mm) (CHSDR5085).....**94.00**
- Top French Flag S16 (Foldable) (CHC41029).....**97.85**



**O-BOX WM Set (15mm LWS)**

Includes the O-Box WM matte box, a wide mini sunshade, top flag, two 4 x 4" filter frames, two 4 x 5.65" filter frames, and a 15mm LWS rod bracket.



- #OCOBSL.....**1099.00**
- O-Box WM Side Flag Bracket Set (2 Brackets) (OCOBFSB).....**159.80**
- O-Box WM Side Flag Set (2 Flags) (OCOBFSF).....**70.55**
- C1243-1117 Bellows Ring (OCBR).....**149.95**
- Studio Adapter (19mm) (OCOBSSA).....**85.00**
- Clamp Ring (150-80mm) (OCCR15080).....**70.55**
- Clamp Ring (150-95mm) (OCCR15095).....**64.95**
- Clamp Ring (150-110mm) (OCCR150110).....**70.55**
- Clamp Ring (150-114mm) (OCCR150114).....**70.55**
- Reduction Ring (114-80mm) (OCCR11480).....**56.10**
- Reduction Ring (114-95mm) (OCCR11495).....**56.10**
- Reduction Ring (114-110mm) (OCCR114110).....**56.10**



**Wide Angle Matte Box for 4 x 4" Filters**

Includes a wide angle matte box with 105mm attachment, 4 x 4" rotating filter tray, 4 x 4" fixed filter tray, wide angle rayshade, GARD donut adaptor ring, GAR step-down adapter ring, and an adapter unit for 15mm and 12mm bars. Standard lenses as well as wide angle lenses can be accommodated using the wide rayshade.



- GWMC (GEGLGWMC).....**433.00**
- Universal Donut "Nun's Knickers" Adapter (GEGARDNK).....**63.00**
- GFF French Flag Assembly (GEGFFW).....**89.00**
- 52mm (GEGAR52), 58mm (GEGAR58), 67mm (GEGLAGAR67), 72mm (GEGAR72), 77mm (GEGAR77) or 82mm rings (GEGAR82).....**36.00**



**microMatteBox Standard Bundle**

Accommodates any lens – whether camcorder, film, DSLR, or 35mm lens adapter.

With its convenient swing-away design, this cinema-grade lens attachment allows the use of 4x4" and 4x5.65" filters that can rotate 360° or be easily swapped out for different looks. Everything on the microMatteBox can be easily locked, adjusted, or simply removed.



- #RE80030042.....**670.00**
- microMatteBox French Flag (RE1130024).....**50.50**
- microMatteBox flag kit (RE80030048).....**147.50**
- microMattebox hard case with 15mm foam (RE1200001).....**245.00**
- Donut Kit for microMatteBox (RE80030062).....**19.95**
- microMatteBox Knob Kit in Black (RE80030084).....**24.50**
- microMatteBox Knob Kit in Blue (RE80030102).....**24.50**



**microMatteBox Deluxe Bundle**

Accommodates any lens – whether camcorder, film camera, DSLR or 35mm lens adapter. With its convenient swing-away design, this cinema-grade lens attachment allows the use of 4x4" and 4x5.65" filters that can rotate 360° or be swapped out for different looks. Light spillage and lens flare are controlled by a top/bottom French flag and a pair of side wings that can be locked, adjusted or removed.



- #RE80030043.....**995.00**
- #RE80030044 (microMatteBox Deluxe Bundle for RED One)....**899.00**



**Manfrotto SYMPLA**

**Flexible Mattebox**

Unconventional design features an accordion-like rubber hood that serves many purposes very effectively. It allows universal compatibility with lenses from wide to long; it can be pressed up against glass – when you need to shoot through glass – to just about completely block out reflections; it protects the lens against knocks and scrapes; it packs flat for transportability. Mounts and moves along two 15mm rods and vertically adjusts 50mm to align with any lens. Has two 4 x 4" filter holders (one of which rotates). (MAMVA512W).....**607.10**



**SYMPLA Mattebox System**

This system adds a Variable Plate and 12" rods to the SYMPLA flexible mattebox. The Variable Plate is a quick-release camera plate that adjusts at a lateral axis to offset the camera from the plate's center, at a vertical axis to align the plate higher and lower, and that adjusts back and forth along the rods, exactly the way the Universal Mount does and in conjunction with the Universal Mount.



#MAMVA512WK.....**849.90**

**MOVICAM Mattebox MM1**

Features a 144mm rear opening and is compatible with lenses up to 14mm (35mm academy). It is equipped with a 16:9 carbon fiber housing, a French flag and side wings for light control, one fixed / one rotating 4 x 5.65" filter holder, a 15mm mini swing-away bracket, and a 144:114 rubber bellows that can optionally be stepped down. The swing-away bracket provides industry-standard 15mm rod support.



- #MOMM1.....**1087.00**
- Mattebox MM2:** 16:9 ABS Housing, French Flag, Side Wings, one Fixed and one Rotating 4x5.65 Filter Holders, Ø 130mm Clamp Adapter, Mini 15mm Swing Away Bracket (MOMM2).....**916.00**
- Mattebox MM3:** 16:9 ABS Housing, French Flag, Side Wings, one Fixed & one Rotating 4x4 Filter Holders, Ø 104mm Clamp Adapter, Mini 15mm Rod Clamp Bracket (MOMM3).....**584.00**
- Clamp-on Mattebox MM102 (MOMM102).....**854.00**
- Mattebox MM1A (MOMM1A).....**1363.00**
- Mattebox MM5 (MOMM5).....**1980.00**
- Universal Stretch Donut (130mm) (MOARU130).....**71.00**
- Universal Stretch Donut (144mm) (MOARU144).....**71.00**



**MB-1B Matte Box Case**

Organizes all the parts of the matte box so it can be quickly transferred to the camera lens. Made from 1000 denier water-resistant Cordura nylon with a rigid interior frame and a fully foam padded interior. Large front outside pocket for accessories and a mesh pocket inside the top that allows viewing the contents.



#POMB1B.....**172.73**

**Dinkum Matte Box Accessories**

- FlareDinkum COMPACT (DI3020).....**35.95**
- FlareDinkum PRO French Flag Assembly (DI3037).....**67.45**
- FlareDinkum CINE French Flag Assembly (DI3044).....**71.95**

800-947-1186 | 212-444-6686



**RFD15BC** Basic Mini Single Wheel Follow Focus

Ideal for mini-DV / prosumer cameras, horizontal adjustment allows for use on different lens types and sizes. Entirely geared transmission provides smooth operation and minimal backlash. Can be used in a dual setup to control both focus and zoom. Removable marking plate lets you mark focus points during rehearsal and then use those points as guides during the actual shoot.



- #CARFD15BM (for Mini-DV / prosumer cameras) ..... **211.95**
- Follow Focus Speed Crank Lever (CARFSCA)..... **34.95**
- 12" Whip for Cavigation Follow Focus (CARFW12) ..... **39.50**
- 18" Follow Focus Whip (CARFW18) ..... **49.95**

Follow Focus Gear Ring for:

- 61-65mm (CARFGR63), 73-76mm (CARFGR75), 78-81mm (CARFGR80) or 82-86mm lenses (CARFGR85)..... **18.45**
- Small Film Lens Gear for RFF-15 (CAFMM0828)..... **16.95**
- Medium Film Lens Gear for RFF-15 (CAFMM0834) ..... **17.49**
- Large Film Lens Gear for RFF-15 (CAFMM0844) ..... **17.49**
- Cinematographers 65' Tape Measure (CARFTMM20)..... **17.95**



**EV2** DSLR Follow Focus Kit

Kit consists of the FG Follow Focus Cine Kit and the EV2 Adjustable Baseplate. With the adjustable baseplate, you can achieve easy left, right, forward, and backward maneuverability. You can use the FG Follow Focus with all Ikan Elements kits or any 15mm rod-based camera support system. An integrated 2" diameter control wheel allows the follow focus to offer low backlash. Included 17" FG Follow Focus Whip integrates a vinyl covering and a crank stability grip for smoother and enhanced control.



- #KELEFGSBBP ..... **494.00**

**ELE-FGK** Follow Focus Cine-Kit

Driven by a 2" diameter control wheel and 2.3" diameter focus gear, offers you smooth and precise focusing even when your subject moves. Featuring low backlash, horizontal adjustment and compatibility with standard film pitch gearing of .8 MOD, the follow focus system can be used with a number of lenses with varied diameters. 17" FG Follow Focus Whip with vinyl covering and a crank stability grip offers smooth control over focusing. Compatible with all industry-standard 15mm rod-based camera support systems.



- #KELEFGK ..... **369.95**
- 2.5-4.25" Diameter Adjustable Zip Gears (KELEFGKLG) ..... **45.00**

**OConnor CFF-1**

Cine Follow Focus One

Modular design eliminates the need to juggle separate bridge plates. A single snap-on bridge clamps onto either 15mm or 19mm studio rod systems.



This lets users straddle the line between both standards with ease and efficiency. Numerous mounting options for specialty setups are possible as the main bridge slides independent of the support bridge dovetail. (OCCFF)**3299.95**

- O-Focus DM Cine Lens Set (OCDMCLS)..... **1860.65**
- O-Focus DM Photo Lens Set (OCDMPLS)..... **1773.95**



**D/Focus V3** Follow Focus

Compatible with cinema lenses, it can be used with still lenses using the optional D/Gear from D/Focus. V3 is a rod-mount follow focus. It mounts and tightens onto two 15mm rods. Once mounted, V3 is a lens-adjustable follow focus. (DFV3).....



- ..... **139.95**
- V3 Follow Focus with D/Gear Lens Gear (DFV3DG)..... **169.95**
- D/Crank Speed Crank for Follow Focus (DFDC) ..... **32.50**
- D/Riser Height Adjuster for V3 Gearbox (DFDR)..... **44.99**
- D/Gear Follow Focus Gear Ring (DFDG) ..... **29.99**

**D/Focus Systems Starter Bundle:** Adds a base plate and rods to provide a significant improvement in your ability to create cinema quality images over a camera on a tripod alone. You'll be able to accurately focus on moving subjects and rack focus between two or more areas in the scene. (DFSB)..... **319.00**

**D/Mount V4** Bundle for Follow Focus and DSLR

New design utilizes a sliding base-plate to adjust the D/Focus similar to a rail system, but in a smaller, more dedicated package. The V4 locks down firmly and won't come loose under normal use. Includes D/Mount V4, D/Focus V3, and a D/Gear Pro Lens Gear.



- #DFDMB ..... **225.00**



**microFollowFocus| Blue**

0.8 film pitch drive gear lets you pull focus of still and cinema lenses. The follow focus includes a backlash dial that enhances focusing precision. Integrated hard stops with begin/end setups enable fast repeatable racking between two focus points, achieving perfect focus on lenses without hard stops. Indicator allows you to pull focus from any place on the camera while maintaining view of focus indicator and focus wheel. Metal machined accessory port lets you add focus whip or speed crank. A Kung Fu rubberized handgrip prevents hand-slips and ensures stable shooting.



- ..... **795.00**
- microFollowFocus Blue Studio (RE30660003) ..... **1190.00**
- microFollowFocus / Blue Indie Bundle (RE160660001)..... **928.50**
- microFollowFocus (RE30660011)..... **595.00**
- microFollowFocus Indie Bundle (RE160061108) ..... **693.50**
- 3" microWhip (RE20140003) ..... **64.50**
- 12" microWhip (RE20140012) ..... **69.50**
- 18" microWhip (RE20140018) ..... **74.50**
- microWhip Bundle (REWBUNDLE)..... **208.50**
- microLensGear (Black) Size A (RE32000004)..... **44.50**
- microLensGear (Black) Size B (RE32000005)..... **44.50**
- microLensGear (Black) Size C (RE32000006)..... **44.50**
- microLensGear (Black) Size D (RE32000007)..... **44.50**
- microLensGear (Blue) Size A (RE32000014)..... **44.50**
- microLensGear (Blue) Size B (RE32000015)..... **44.50**
- microLensGear (Blue) Size C (RE32000016)..... **44.50**
- microLensGear (Blue) Size D (RE32000017)..... **39.95**
- microLensGears Kit - 4 Gears (Black) (RE80030107) ..... **178.00**
- microLensGears Kit - 4 Gears (Blue) (RE80030108) ..... **178.00**
- microFollowFocus Reversing Gear (RE80030049) ..... **45.00**
- microSpeedCrank (RE3019FFC)..... **49.50**
- microLensGear Replacement Screw Set (RE80090003) ..... **25.00**



**Bravo Deluxe** Follow Focus System

Features end stops, 0.5/0.6mm pitch gear utility, and gear tension adjustment to prevent backlash. Rotates the focus ring of your lens by 360°. Pair it with a flexible lens gear ring to make a complete follow focus package.



- #GEGLBGFODEL ..... **629.95**
- #GEGFG (Follow Focus Flexible Lens Gear Ring) ..... **63.25**
- #GEGLPG08 (Superior Follow Focus 0.8 Pitch Gear) ..... **38.25**



**MF-1** Mini Follow Focus

Single-sided variable lock. Includes 0.8 gear drive, flexible gear ring, focus scale, mounts onto mini 15mm rods. (MOMF1).....



**MF-2** Mini Follow Focus

Single sided. Includes 0.8 gear drive, flexible gear ring, focus scale. Mounts onto mini 15mm rods. (MOMF2)..... **727.00**

- Flexible Gear Ring (MOFGR)..... **43.00**
- 12" Follow Focus Flexible Whip (MOFFFW)..... **93.00**



**Friction & Gear Follow-Focus Clic** with Adjustable Marker

Attaches to standard 15mm rods via clamp. The focus mechanism also works with a clamp system, which when unlocked loosens the focus mechanism and allows it to be moved horizontally. The focus disk can either be a friction wheel or a gear wheel (both included).



- #SHFFCLIC ..... **491.92**
- Friction & Gear Follow-Focus Riser Rail Kit (SHFFROD2)..... **553.52**
- Lens Gear Kit: 0.8 Pitch for Still Lenses (SHLGKIT8) ..... **126.28**



**Z-FF-1** Z-Focus Single 15mm

Completely gear-driven design for slip free, accurate movement.

Helical gear adjustment screw allows you to tighten up gear play. Standard accessory port for follow focus whips and speed cranks. Includes dry erase marking disc that allows the camera operator to see focus marks.



- (ZAZFF1) ..... **1021.25**
- Z-Focus with ZipGear Prime Lens Kit (ZAZFF1ZGK) ..... **1273.00**
- ZWIP Follow Focus Accessory (ZAZW1)..... **141.55**
- Z-ZG-16 ZipGear (ZAZZG16)..... **64.60**
- Z-ZG-16R ZipGear Strand (ZAZZG16R) ..... **11.40**
- Z-ZG-16S ZipGear Strand with Stop (ZAZZG16S)..... **89.30**
- Z-ZG-PLK4 ZipGear Prime Lens Set (ZAZZGPKL4) ..... **251.75**
- Z-Focus Extender (ZAZFFE) ..... **90.25**

- Digital Juice** Standard Follow Focus (DIFFSQ)..... **233.50**
- Digital Juice** Follow Focus Pro (DIFFP) ..... **373.95**
- Letus35** Follow Focus (LELTFF)..... **839.95**
- Chrosziel** Focus Drive Mod 0.8 - 36.8mm (CH20122)..... **105.45**
- Chrosziel** Gear Ring for Canon 24-70mm (CHC206836) ..... **188.10**
- Chrosziel** Flexi Gear Ring (60-120mm) (CHGR60120) ..... **153.90**
- Wide Open Camera** Lens Gear in Small (18.00), Medium (WILM210), Medium Plus (WILM235) or Large (WILL255)..... **18.00**
- Wide Open Camera** Universal Lens Gear (WILU)..... **21.00**



**RS-15IIM Rod Support System for HDV Camcorders**

Heavy-duty rod system incorporates two carbon fiber rods, mini-DV camcorder mounting plate, and vertical and horizontal adjustments with locating pin for enhanced stability. 250mm back and forward adjustable length. (CARS15IIM) ..... **153.50**  
 #CARS15IIM200 (200mm adjustable length) ..... **144.95**



**DS-SB15-SP1**

15mm Rod Camera Support System

Works in conjunction with Century's matte boxes. Utilizes 15mm aluminum rods and a base plate to hold up the matte box. Also features an integrated shoulder bracket. (CEDSSB15SP1) ..... **349.00**



**Simplis Rails Assembly Kit**

Lets you attach rails to a Simplis quick release plate. Consists of a pair of 15mm solid carbon fiber rails, a pair of 15mm universal rails blocks and a tripod adaptor plate. Using the kit, you can mount multiple accessories to your system. #CISRAK ..... **184.98**



**Cine Bundle Camera Support**

Cine Bundle is a serious tripod-mounted camera support and one of the simplest and most affordable ways to "Cinema-ize" your DSLR. It includes the JAG35 DLSR Baseplate with 8" rods, the D/Focus V3, D/Gear, D/Crank and the D/Matte Matte Box. (DFCB) ..... **749.95**  
 Starter Bundle (DFSB) ..... **329.95**



**GMB/DSLR Adapter Bar System**

Support adapter suitable for most DSLR cameras, the GMB/DSLR offers a higher "seat" to accommodate different cameras and optional add-ons, such as audio adapters. The GMB/DSLR can be maneuvered horizontally and vertically, providing perfect alignment with a mattebox and lens, all with just with a twist of a knob. #GEGMBDSL ..... **233.00**  
 Hot Plate Adapter Bar System (GEGLGMBHP) ..... **389.00**



**Redrock Micro**

Studio Bundle for Panasonic AG AF-100 (RE21066110) ..... **1928.00**  
 Studio Bundle for Sony FS-100 (RE210660005) ..... **2177.50**

**Zacuto**

C300 Studio Baseplate with 12" Rods (ZAZCSB) ..... **380.00**  
 Single Action Tripod Kit (ZAZDSAB) ..... **1467.00**  
 Studio Baseplate for Scarlet and Epic Cameras (ZAZESSB) ..... **441.75**  
 DSLR Baseplate with Rods (ZAZDSLBB) ..... **399.00**

**OConnor C1245-1001**

Universal Baseplate

Allows you to attach accessories to small and medium sized digital cine cameras, and offers a sturdy support to keep the lens parallel to the rods. Consists of four rods, two 1/4" and one 3/8" 3-way camera screws, dual 15mm LWS horizontal rod brackets, top and bottom camera plate. (OCUBP) ..... **499.95**



**Z-M-UB Mini Baseplate**

Designed for DSLR cameras like the Nikon D90 and Canon 5D Mark II, the baseplate puts dual 15mm rods in front of the lens so you can attach a matte box, follow focus, or other device. Can also be used with flat-bottomed camcorders such as the AG-HPX170. #ZAZMUB (Mini Baseplate) ..... **408.50**  
 #ZAZUB3 (Universal Baseplate V3) ..... **408.50**



**ROD ACCESSORIES**

**Cavision**

Dual Handgrips for 15mm Rods (CARHD1560) ..... **79.00**  
 Lens Support with metal lens fastener (CAR15LS2510M) ..... **74.95**  
 15mm Aluminum Rod 8" - Pair (CAAT1520) ..... **26.95**  
 15mm Carbon Fiber Rods 10" - Pair (CATC15225) ..... **39.95**  
 RS15HS Single Handgrip for 15mm Rods (CARS15HS) ..... **49.95**  
 R156025 Bracket for 15mm Rods (CAR156025) ..... **33.95**  
 Lens Support with Trimmer Knob (CAR15LS25100) ..... **79.95**  
 RPSHC Spacer for Smaller Camcorders (CARPSSH) ..... **23.95**

**Element Technica**

8" 15mm Ultra Rod (ELUR58) ..... **39.95**  
 12" (ELUR512) ..... **49.95**    15" (ELUR515) ..... **60.00**  
 18" (ELUR518) ..... **64.95**    24" (ELUR524) ..... **79.95**  
 18" 19mm Stainless Steel Rod (ELSS918) ..... **64.95**  
 24" 19mm Stainless Steel Rod (ELSS924) ..... **79.95**

**IndiPRO Tools**

DSLR Baseplate with 9" 15mm Rods (INDIB) ..... **99.00**  
 Baseplate & Follow Focus Combo (INFFK) ..... **219.00**

**Redrock Micro**

microSupport Baseplate with 4" Rods (RE80030050) ..... **383.00**  
 microSupport Baseplate (RE30140002X) ..... **305.50**  
 microSupport Baseplate (RE30140002) ..... **249.50**  
 Lightweight Support Arm 15mm (RE20380010) ..... **72.50**  
 Pair of 15mm Iris Rods  
 9" (RE80030013) ..... **79.00**    12" (RE80030014) ..... **89.00**  
 18" (RE80030015) ..... **99.00**    24" (RE80030016) ..... **119.00**  
 15mm Single 2" Carbon Fiber Rods  
 2" (RE2110007) ..... **16.00**    4" (RE2110006) ..... **32.00**  
 6" (RE2110005) ..... **36.50**    9" (RE2110004) ..... **39.50**  
 12" (RE2110003) ..... **44.50**    18" (RE2110002) ..... **49.50**  
 Pair of 15mm Carbon Fiber Rods  
 2" (RE80110007) ..... **32.00**    4" (RE80110006) ..... **64.00**  
 6" (RE80110005) ..... **72.50**    9" (RE80110004) ..... **79.00**  
 12" (RE80110003) ..... **89.00**    18" (RE80110002) ..... **99.00**

**BRACKETS, CLAMPS & PLATES FOR RODS**

**Genus**

GAP Adapter Plate (GEGAP) ..... **122.00**  
 Height Extension Bracket (GEGLGHEB) ..... **125.00**  
 Matte Box Adapter (GEGLGSP40003) ..... **63.75**  
 Uni-Plate Adapter Bar System (GEGLGMBUP) ..... **418.00**

**Redrock Micro**

microRiser (RE80170018) ..... **224.50**  
 microRiser (Quick Release) (RE20640001) ..... **210.00**  
 microClamp (RE32000020) ..... **79.50**  
 microLink3 (67.50), microMount (RE4250001) ..... **67.50**  
 microLensSupport (RE20400001) ..... **128.50**  
 microMount (3 Pack) (RE80030024) ..... **202.50**  
 microPod Accessory Plate (RE20380002) ..... **152.50**  
 microLink4 Riser (RE20570002) ..... **106.49**  
 microOmniMount (RE3033SA) ..... **157.50**  
 microMount with Cold Shoe Spud (RE81120001) ..... **91.00**  
 microShoulderMount Offset Kit (RE80030080) ..... **67.50**

**SHAPE**

Sliding Rod Block (SHRODSUP2) ..... **60.72**  
 Double Sliding Rod Block (SHRODSUP3) ..... **116.16**  
 Paparazzi Riser (SHRISERPA1) ..... **87.12**

**Movcam**

4" 15mm Aluminum Rod (MORA4) ..... **19.00**  
 8" (MORA8) ..... **28.50**    12" (MORA12) ..... **38.00**

**SHAPE**

Pair of 15mm 8" Female - Female Rods (SH2ROD15FF8) ..... **48.84**  
 Pair of 15mm 4" Male-Female Rods (SH2ROD15MF4) ..... **40.48**  
 Pair of 15mm 6" Male-Female Rods (SH2ROD15MF6) ..... **44.00**  
 BP0007 V-Lock Quick Release Base Plate (SHBP0007) ..... **905.52**

**Zacuto**

1/2" Rod Cap (Black) (ZAZRC1B) ..... **11.40**  
 1" Male/Female Rod Extension (ZAZREFM1) ..... **19.00**  
 2" Male/Female Rod Extension (ZAZREFM2) ..... **20.90**  
 2" Male/ Female Rod Extension in Black (ZAZBREFM2) ..... **20.90**  
 2" Female to Female Rod Extension (ZAZREFF2) ..... **18.00**  
 3" Female to Female Rod Extension (ZAZREFF3) ..... **21.60**  
 3" Female / Female Rod Extension Black (ZAZBREFF3) ..... **22.80**  
 3.5" Male/Female Rod Extension (ZAZREFM35) ..... **23.75**  
 3.5" Male/ Female Rod Extension in Black (ZAZBREFM35) ..... **23.75**  
 4.5" Female/Female Rod Extension (ZAZREFF45) ..... **28.50**  
 4.5" Male/Female Rod (ZAZREFM45) ..... **28.50**  
 4.5" Male-Female Rod - Black (ZAZBREFM45) ..... **28.50**  
 6.5" Female Rod Extension (ZAZBREFF65) ..... **61.75**  
 7" Rod Extensions (2) (ZAZREM7) ..... **66.50**  
 7" Male / Female Rod Set in Black (ZAZBREM7) ..... **66.50**  
 8" Support Rods (ZAZREFF8) ..... **66.50**  
 10" Rod Extensions (2) (ZAZREM10) ..... **80.75**  
 10" Male Rod Set (ZAZBREM10) ..... **80.75**  
 12" Rod Set 12" (ZAZRSM12) ..... **80.75**  
 12" Female / Female Rod Set in Black (ZAZBRSM12) ..... **80.75**  
 Z-Mount Zwiwel (ZAZMOZW) ..... **80.75**  
 Zround Mount (ZAZRM) ..... **114.00**  
 Wireless Plate Pro (ZAZWPP) ..... **52.25**  
 Zicro Mini (ZAZZCM) ..... **47.50**  
 T-Mount Rod Adapter (ZAZTM) ..... **71.25**  
 Tri-Mount Rod Adapter (ZAZTRIM) ..... **114.00**

**Zacuto**

Z-ZC ZicroMount (ZAZZC) ..... **71.25**  
 ZM-3 Zicromount III (ZAZM3) ..... **87.40**  
 Z-MO-2 Z-Mount II (ZAZM02) ..... **95.00**  
 1/4 20" Lens Support (ZAZ14LS1) ..... **225.15**  
 1/4 20" Lens Support with 2.5" 15mm Rods (ZAZ14LS25) ..... **225.15**  
 Zwing Away Adapter for 15mm Rods (ZAZZWING1) ..... **375.25**

**Anton Bauer** 15mm Rod Clamp Kit (AN15MMRCKIT) ..... **122.50**  
**Anton Bauer** MATRIX Cheese Plate (ANMATCHSPILT) ..... **149.95**  
**Chrosziel** Center Bracket (CH42002) ..... **153.90**  
**Chrosziel** AC-403-10 Handgrips (CH40310) ..... **119.70**  
**Movcam** Clamp Adapter for Shoulder Pad (MOCA) ..... **65.00**  
**Movcam** Rosette Hand Grip Adapter (MOHGA15) ..... **333.00**  
**Movcam** Monitor Bracket (MOMBMM) ..... **109.00**  
**OConnor** O-Grips Three System Rod Bridge (OCGRB) ..... **374.85**  
**OConnor** 18" 15mm Pair Rods (OC1815HSR) ..... **113.90**  
**Okii** MC1 USB Mini Controller (OKMC1) ..... **250.00**  
**Okii** FC1 USB Focus Controller (OKFC1) ..... **350.00**  
**Okii** Function Micro Clamp (OKAC009) ..... **40.00**  
**Okii** Function Multi Lock Clamp (OKAC018) ..... **55.00**  
**Vocas** Sony EX-3 Base Reinforcement Plate (VOBPSX3) ..... **136.95**

800-947-1186 | 212-444-6686



**DSRL-EgripZ**  
Handheld DSLR Support



Wide, flexible handles allow one hand to support the camera while the other is free to manipulate the shutter and other controls. Handles can also be twisted in opposite directions or to one side for use as a shoulder or chest mount.

#ANEGRIPZDSRL..... **86.50**



Shoulder Pad Packages for DSLR Cameras

Increase endurance and reduce jitter while shooting with the EOS 5D MKII or other video-enabled DSLR. Viewfinder magnifies the LCD image by 6x for finer control over critical focus and scene framing. Two pistol-style handgrips attach to the front of the 12" 15mm rods. Camera is easily removed from the rig, enabling quick switch from shoulder-mounted to handheld shooting. System with follow focus device puts smooth control over your lens's focus ring.



- #CAMH3QRSD (with Follow Focus)..... **626.95**
- #CAMH3QRSDBT (with Flat Camera Plate & Viewfinder)..... **393.50**
- #CAMH3QRSDL (Standard Package for 7D & T2)..... **399.00**
- #CAMH3QRSDFL (with Follow Focus for 7D & T2)..... **569.95**
- #CARSA1580DS (Shoulder Pad with Dual Handgrips)..... **177.95**
- #CARSA1580SSP (Shoulder Pad with Single Handgrip)..... **159.95**

**Triple Handgrip Cage**

Compact DSRLR Support

Simple way to manage devices needed for shooting video – there are multiple 1/4" and 3/8" mounting points to which you can mount mics, monitors, lights, etc. The cage uses 15mm rods and has an 8.66" vertical distance between rod placement sites. It also features side handles and a top handle.



#CARHD1915U22..... **299.00**



**HDV Cage Kit**

Heavy-duty cage designed to hold accessories like monitors, LED lights, and microphones. Compatible with most HD/SLR cameras, it can be used hand-held or mounted to a tripod. It's made from durable, lightweight aluminum with a black anodized finish. Includes two wire keepers to keep things well-organized. (CUHDVCK)..... **179.95**



**HDV PRO Kit**

Compatible with HD/SLR cameras, it is designed to hold accessories like monitors, mics and lights. Using the camera's neck strap, it offers a balanced, stable setup. Foam covered grips offer a firm and comfortable grip of the entire setup. Can be attached to a tripod or monopod. Adjustable camera mounting plate allows easy access to the battery door and includes two extension bars for proper alignment of any component. (CUHDVPK)..... **224.95**



**DSLR Shoulder Shooter Kit**

Carbon rail kit includes is a pair of 12" and 20" precision ground carbon fiber rails. Connect the dual side grips to the single uni strut. With a handle kit and single small uni strut/side strut, the kit provides multiple attachment points for monitors, XLR adapters, and follow focus systems. Also integrates a shoulder pad for comfort and a belly pan. (CPSDS)..... **463.95**



**Street Runner Bundle**

Lightweight rig for DSLR shooters with three points of contact—one hand on the handle, a chest pad on your chest and your focusing hand on the follow focus. Allows you to mount many accessories to the rig. It includes the JAG35 Field Runner Rig, a very compact and lightweight shoulder rig, V3 Follow Focus, Follow Focus Gear Ring and D/Crank Speed Crank. #D|FSRB..... **479.95**



**Field Runner Bundle**

Ergonomic offset shoulder rig for DSLR shooters on a budget or on the go. Shooters who use the camera's LCD display with or without a viewfinder for monitoring prefer the Field Runner Bundle because it places the camera in front of the face. Includes the JAG35 Field Runner Rig, a very compact and shoulder rig, V3 Follow Focus, Follow Focus Gear Ring and D/Crank Speed Crank. (D|FFRB)..... **534.95**



**V1 Magic Rig**

Lightweight support rig with a height-adjustable baseplate and a quick-release plate. Provides two points of contact, so one hand holds the grip as the gunstock steadies the rig against the chest or bicep; meanwhile the other hand is free for adjusting zoom and focus, changing camera settings, and triggering recording. (DODLV1)..... **94.95**  
Accessory Kit for V1 (DODLV1A1)..... **39.95**  
HDSLRL Rig V5 Shoulder Hand Brace (DODLV5)..... **109.95**  
Video Stabilizer with Grip and Quick Release (DODLV0375)..... **69.00**  
P&C Handgrip (DOPCGRIP)..... **19.95**



**DL-V9 HD/SLR Camera Support**

Simple, lightweight method of providing support for your camera when shooting video, while keeping both hands free. It features an adjustable, padded breathable body harness, support column that can be angled up to 180° and a camera platform that tilts ±45°. Weighs only 3 lbs. while supporting up to 10 lbs. Includes a zoom control ring, quick release plate, anti-twist plate, waist strap and nylon bag. (DODLV9)..... **149.95**



**Studio FloPod I Video Stabilizer**

Innovative stabilizing support for HD/SLR cameras. Mounted to a C-bracket, the camera's weight pulls the bracket left & right, resulting in horizontally stable framing even as you walk and tilt the handgrips slightly side to side. A zoom ring with large lever allows you to zoom in and out with a single finger while you keep the rest of your hand on a grip. Also includes counterweights for more fluid motion. (DORS3124)..... **249.95**



**GCSMK Shoulder Mount**

Modular, easy-to-assemble support rig provides stability and comfort for long shoots. Included base plate, handgrips, shoulder mount, and counterweight. All are adjustable to perfectly balance your camera and accessories on your shoulder. 15mm rods let you accessorize with a mattebox, follow focus, or audio recorder. (GEGCSMK)..... **650.00**



**GL GSBK Shoulder Brace System Kit**

Mount your video-enabled DSLR camera and shoot jerk-free videos. Featuring the shoulder brace with protective pad, it allows you to shoot stable video. With a flexible design based on 15mm rods, the brace system allows you to configure it according to your shooting style. The length and angle of the shoulder brace can be adjusted for comfortable shooting. (GEGLSBK)..... **599.99**



**ikan Flyweight DSLR Camera Stabilizer**

Easy-to-use shoulder-mounted rig for DSLR cameras that delivers key components preassembled for your convenience. Enhanced lightweight shoulder pad system rests comfortably on your chest and shoulder, with a soft weight bag that is shipped empty and filled with the weight material of your choice. The baseplate can be adjusted for height and side-to-side and the tripod mounting plate accepts industry-standard quick-release or larger wedge-style plates. Rubberized non-slip grips absorb moisture to give you a solid grip on your equipment at all times. (IKELEFLWDSLRL)..... **349.95**  
Universal Grip Bar (IKELEUGRIP)..... **13.36**  
15mm Pair of 6" Rods (IKELE15R6)..... **26.86**  
15mm Pair of 9" Rods (IKELE15R9)..... **29.56**  
15mm Pair of 12" Rods (IKELE15R12)..... **31.36**  
15mm Pair of 18" Rods (IKELE15R18)..... **39.95**  
15mm Pair of 24" Rods (IKELE15R24)..... **48.95**  
15mm Rod Adapter (IKELE15RDA)..... **22.36**  
Elements DoubleCheese Plate (IKELEDBLPT)..... **53.86**  
D-Ring Screws (IKELEDRING)..... **5.35**  
ELE-PT Cheese Plate (IKELEPT)..... **31.36**  
Elements Pinch Clamp (IKELEPN)..... **26.86**



**K-Tek.****Norbert Sport Frame**

Camera mounting frame for HD/SLR and compact HD cameras. Constructed from machined aluminum, the top plate features nine cold shoe sockets and multiple 1/4-20 and 3/8-16 threaded holes for flexible mounting of accessories. A handle with quick release provides a sturdy grip for a mounted camera. Two carbon fiber, foam-covered side handles provide convenient handling of the entire frame. Use with 15mm rail systems.



#KTKN2285.....**256.50**

**Manfrotto****SYMPLA****Fig Rig Version**

Walk around and make quick and wide movements, holding the rig as a steering wheel with a camera mounted near its lower center.



Universal Mount is attached to that center and can take on 15mm rods (and anything else attached to them). Or, you can remove the mount and attach a camera plate in its stead. The crossbar adds two more 3/8" screw-holes and one 1/4"-20 screw-hole for mounting compatible accessories. (MAMVA522W).....**329.99**

**Manfrotto****SYMPLA****Highly Adjustable DSLR Shoulder Rig**

With 3 axis you can slide the camera up and down the rods, offset the camera from the plate's center, and align the plate higher and lower.

This allows the camera to be set up for different types of shots and the viewfinder to be positioned right in front of your eye.

Swivel-joint adjustable handles can be set in almost any position — vertical, horizontal, up-side down, and every other in between. They can be set closer together, wider apart, and rotated 360°, allowing comfort and precision. Once you find the right position, just lock it in place — each handle has its own locking dial (and each handle can be positioned differently). The SYMPLA also help incorporate optional remote controls to the rig. SYMPLA offers two different remote control units for adjusting focus on DSLRs.

Every component of the rig is easily detachable thereby giving you the flexibility to reconfigure your rig with other optional components should you ever want to.



#MAMVA511WK.....**849.95**  
 Universal Mount (MAMVA517W).....**64.99**  
 V-Offset (MAMVA524W).....**159.99**  
 H-Offset (MAMVA519W).....**159.99**  
 6" Rods (MAMVA523W).....**64.95**  
 12" Rods (MAMVA520W).....**84.95**  
 Adjustable Handles (MAMVA518W).....**299.99**  
 Shoulder Pad (MAMVA511W).....**139.99**  
 Lens Support (MAMVA514W).....**89.90**  
 Counterweight (MAMVA521W).....**99.99**  
 Clamp-On Remote for Canon DSLRs (MAMVR911ECCN).....**329.56**  
 Fixed Plate (MAMVA513W).....**279.99**  
 Variable Plate (MAMVA515W).....**349.99**  
 Deluxe Remote for Canon DSLRs (MAMVR911EJCN).....**607.10**

**MOVICAM****Camera Cage for Sony PMW-F3**

Solid, lightweight camera cage support for the Sony PMW-F3. Includes a lightweight support with two 12" 15mm rods and a shoulder pad. There's also a top mount that fits directly over the top of a PMW-F3 handle and mounts to the three 1/4"-20 holes — it comes with two 0.74" (19mm) diameter and 13" long rods that can be used to mount other accessories.



#MOCCSF3.....**2630.00**  
 Anti-Skid Handgrip for 0.59" (15mm) Rods (MOHG2).....**185.00**  
 Rosette Hand Grip Set (MOHGSR).....**247.00**  
 Bracket and Converter for Gold-Mount Battery (MOBBGM).....**404.00**  
 Bracket and Converter for V-Mount Battery (MOBBVML).....**404.00**  
 Shoulder Pad (MOPZ).....**93.00**  
 Rosette-Articulating Shoulder Pad Assembly (MOSPR15).....**333.00**  
 0.74" (19mm) Shoulder Pad (MOSPR19).....**265.00**

**CXS-1 Shoulder Stabilizer Support System**

Constructed of an extremely high quality aluminum and stainless steel material, the camera and shoulder pad can be adjusted to fit your body (right or left shoulder) and shooting style. Customize by adding brackets for microphones and lights. Removable grip handle may be used stand alone.

#OPTCX1.....**89.95**  
 CXSB-1 Shoulder Strap Support Belt (OPTCXSB1).....**9.95**  
 HG-1 Heavy-Duty Grip Handle (OPTHG1).....**14.95**  
 CBW-1 Counterbalance Weight (OPTCBW1).....**19.95**

**CXS-200 Dual Grip DSLR Stabilizer**

Dramatically improve comfort and shot quality. The CXS-200 can be used with the handles pointed up for regular shooting, or reversed for higher angled shots. The 15mm universal rail system allows you to customize your rig with accessories such as lights, mics or a follow focus.



CSS-200 Dual Grip DSLR Stabilizer (OPTCX200).....**105.75**  
 CXS-300 Dual Grip Shoulder Stabilizer (OPTCX300).....**179.95**

**X-Cage Video Stabilization Rig for DSLRs**

Sturdy aluminum rig gives you a stable platform for shooting video using your HD/SLR camera. Compatible with 15mm rods, the X-Cage has room for accessories such as monitors, lights, mics, follow-focus system, etc. to be attached. It has eight 15mm thread mounting locations. Four 105mm dual-threaded rails and two 77mm male-threaded rails are included, as are two 90° rail connectors.



#OPTXCAGE.....**110.13**

**Wooden Camera**

WC-142000 1/4-20 Hot Shoe Mount (WOWC142000).....**25.00**  
 QB Battery Back Plate for Anton Bauer (WOWC149600).....**79.00**

**OConnor****O-Grips Double Jointed Set**

Set of modular O-Grips configured to create double handles for custom applications, loads up to 44 lbs. Titanium core based construction provides rigidity and stability for camera mounted operations. Supports 15mm and 19mm Studio and 15mm LWS rod systems. Achieve complete spherical stepless articulation. Accessories as well as multiple-point connection via the 3/8 stainless steel top screw and 3/8 bottom thread. (OCOGRDJS).....**1874.25**  
 O-Grips Single Jointed Set (OCOGRSJS).....**924.95**  
 O-Grips Single Module (OCOGRSM).....**471.75**

**Polaroid Sure-Grip****Camera Stabilizing Handle Mount**

With a stable mount and a comfortable top handgrip for a DSLR or a camcorder, you get an easier way to carry your camera, plus smoother, more stable video shooting at lower levels. Makes it easy to shoot from a skateboard, rollerblades or a bike. Hotshoe adapter allows you to mount a light, remote control, or microphone.



#POPLSTA.....**27.95**

**nano-RunningMan**

By allowing 3 points of contact between yourself and the camera—handgrip, body pad, and camera grip, RunningMan provides a compact, lightweight solution for achieving stable handheld video. Add the optional microFinder, and you add a fourth point of contact for an even sturdier shooting alternative. (RE190010009).....**467.00**

**manCam HD/SLR Camera Rig**

Provides balanced, sturdy support for shooting video with a DSLR camera. Offset handles balance the rig and eliminate rotational motion, even if you're using heavy lenses, or a prosumer video camera. It includes a DSLR baseplate, rubberized hand grips, handlebar rods and handlebar rod clamps, and two 12" carbon fiber rods. (RE15001000).....**615.00**

**theEvent Handheld Rig**

Designed to turn your tall professional HD/SLR into a video rig. Features two handgrips and a microBrace body pad, for three points of contact. theEvent is designed to be held in front of your body so you can move fast, and quickly reposition the camera for high- or low-angle shots. It can be adjusted with 6 lift-and-lock thumbscrews and nearly infinite ways to position the handgrips, body pad and camera. Included 15mm carbon fiber rods let you add a follow focus at any time. #RE81250001.....**779.00**



800-947-1186 | 212-444-6686

DSLR Video Rigs



**microShoulderPad with Rod Clamp**

Fits comfortably on the shoulder using high quality rubberized foam padding. Slide forward or back along the rods and locked in place for perfect balance and support. (RE80170005)..... **197.50**



**DSLR Field Cinema Bundle**

Comprehensive package for converting video DSLRs to useful cinema production rigs. Ideal for DSLRs that have the ability to output an HD picture to an external monitor while recording. Having an HD monitor opens new doors like the ability to allow a Camera



Assistant to pull focus as opposed to the operator. #RE180010003 (Standard Bundle v2)..... **1149.00**  
 DSLR Field Cinema Deluxe Bundle Blue (RE180660001) .... **2121.00**  
 DSLR Field Cinema Deluxe Bundle V2 (RE180661112)..... **1921.00**

**microShoulderMount**

Whether shooting with a tiny camcorder, video DSLR, or ENG-style camera and 35mm lens adapter, this kit not only increases the stability of handheld shooting, it provides new levels of flexibility to how you shoot. The shoulder pad and two rubberized handgrips can be adjusted in nearly any configuration along the included handlebar rods and optional 15mm support rods.

#RE80030022..... **469.00**

**microShoulderMount Deluxe Bundle**

Includes everything in the microShoulderMount Bundle, and adds 18" rods. The Deluxe Bundle is great for camera setups that don't already have a rod support system. (RE80030023)..... **568.00**



**nano - Low Down Deluxe**

Add drama to your handheld and tracking shots. Versatile solution for shooting handheld DSLR video from a variety of angles. One rubberized top handle and two side handles attach to your camera's shoe mount and provide firm, secure grips for positioning your camera at any level from head to toe. (RE190010008) ..... **491.50**



**DSLR Cinema Bundle**

Modular, tripod-mounted system converts your camera for professional-style cinematography. Includes microMateBox, microFollowFocus for precise lens adjustments, two pairs of 12" plus a pair of 9" 15mm carbon fiber rods. microHandle top handle is useful for low-angle shoots. The top handle lets you carry the camera setup with a single hand. (RE180661114) ..... **2407.50**  
 #RE180660005 (with MicroFollowFocus Blue) ..... **2607.00**



**"Captain Stubling" DSLR Rig**

Taking its name from its designer, DV and VFX guru Stu Maschwitz, the rig's design reflects his philosophy on shooting: "Put the camera everywhere, stay light, and do it all yourself." Enabling steady handheld operation for a variety of shooting styles, the rig features the DSLR Baseplate, which puts your camera at the proper level to integrate the microFollowFocus. Dual rubberized handgrips give steady support for your camera even as you pull focus – comfortably, and without any awkward joggling that could ruin a shot. (RE180661105)..... **1147.00**  
 #RE180660007 (with MicroFollowFocus Blue)..... **1347.00**



**theEvent DSLR 2.0 Hybrid Rig**

Stabilized rig designed with wedding, event, or photojournalism shooters in mind. It features two handgrips, a microFinder loupe eyepiece (loupe not included), and microBrace body pad. Setup affords maximum stability and mobility with a very low overall weight. #RE80170016..... **794.50**



**eyeSpy**

**eyeSpy Standard:**

A cost-effective base package, starts with shoulderpad, 18" 15mm carbon fiber rods, and single rubberized handgrip. Then adds rod extension to center the camera for viewfinder use, and tops it off with the DSLR baseplate, and microFinder loupe accessory. #RE80170011..... **771.50**



**Redrock Micro DSLR Video Rig Accessories**

- microHandle (RE20160001) ..... **172.50**
- microHandle Plus (RE20160002) ..... **195.00**
- microHandGrip (RE2190009) ..... **74.50**
- microHandGrip Accent Kit (RE80030091)..... **21.50**
- microSupport Cheeseplate (RE332CP)..... **80.00**
- microShoulderMount Rod Clamp (RE80030041)..... **67.50**
- microBrace Body Pad (RE80170017)..... **243.50**
- microMount (w/out Spud) (RE20250001) ..... **59.50**
- microSpud (RE20250002) ..... **8.00**
- microLink4 Riser Offset Accessory Kit (RE80170015)..... **179.00**
- microTie Cable Organizers (3 Pack) (REMT3P)..... **24.50**
- nano Focus+Zoom Lever (RE20690001) ..... **34.50**
- Double Handgrip Acc. Kit for eyeSpy (RE80170013) ..... **197.00**
- 4" Grip Rod (RE2190011)..... **49.50**
- 8" Grip Rod (RE2190010) ..... **54.50**
- 4" Handlebar Rod (RE80170002) ..... **15.00**
- 8" Handlebar Rod (RE80170003) ..... **22.50**
- Handlebar Clamp (RE20170002) ..... **85.00**
- Clamp - 15mm for Really Right Stuff (RE20840001) ..... **199.00**
- DSLR Tripod Platform (RE80170007)..... **184.00**
- DSLR Baseplate (RE30430002) ..... **174.50**
- DSLR Mini Tripod Platform (RE20740001)..... **59.00**
- backPack Accessory Kit for ultraCage (RE31160001) ..... **125.00**
- microShoulderMount Hardware Kit (RE32000021)..... **35.00**
- powerPack Kit for EOS C100/C300 (RE81080001) ..... **409.95**
- Cold Shoe Mounting Spud (RE21120001) ..... **32.00**



**Universal Shoulder Pad**

Offers extra cushioning for various DSLR shoulder-mounted rigs or for certain shoulder-mounted broadcast cameras. The bottom of the pad is covered with an anti-skid dot fabric. The pad attaches to a camera or to rig hardware via three hook-and-loop fasteners. (POSP3G)..... **45.00**



**witronix DSLR-PRO/C**

**DSLR Camera Shoulder Support**

Constructed from machined aircraft aluminum for durability, an elevated platform ensures that the DSLR viewfinder is raised to eye level. Three-axis movement allows for extreme mobility when positioning your shots. A short slide channel allows for wide-angle shots without visual interference. Includes a Series 7 battery mount for use with Canon EOS 5D and 7D cameras. (SWDSLAPROC)..... **269.00**



**PAPARAZZI I**

Handle offers a stable base, letting you shoot shake-free videos. Features a large external frame with a variety of threaded holes on the sides, and top and below the handle, for attaching accessories like lights, monitors, mics, grips, etc. Attaches to a tripod using an optional quick release plate. (SHPA1100)..... **198.44**  
 Paparazzi with Bloc (SHPA001BLOC)..... **207.24**



**Composite Stabilizer Camera Support**

Hand-held support with an adjustable camera platform. Features back pad, adjustable composite shoulder pad, two 15mm 6" rods, rod block, 15mm rod riser system, quick handle, telescopic support arm with rod block. The Adjustable Composite Shoulder Pad rests on your shoulder such that the body supports the weight of the camera and its accessories and is padded for superior comfort. Back pad fits any body type with a vertical adjustment range of 1 1/2" and a horizontal adjustment spanning 360°. #SHCOMPOSTAB ..... **879.00**



**Shape Individual Components**

- Quick Handle + Rod Block (SHHAND5)..... **307.12**
- Lens Support (SHLENSSUP1) ..... **98.56**
- Counter Weight (SHPADCW1) ..... **60.72**
- 15mm Rod Riser System (SHROD2) ..... **175.12**
- Shape Belt (SHBELT1)..... **60.72**
- Telescopic Support Arm + Rod Block (SHARM2)..... **219.12**
- Composite Shoulder Pad (SHSHPAD1)..... **157.52**
- Adjustable Composite Shoulder Pad (SHSHPAD2) ..... **148.72**
- Paparazzi I Handle (SHPA001)..... **148.72**
- Double Bracket for Paparazzi II Frame (SHBRAC1)..... **43.12**
- Counter Weight (SHPADCW1)..... **60.72**
- Female Spigot 3/8" 16 to 1/4" 20 (SHSPIGOTF1) ..... **5.28**
- Male Spigot 3/8" 16 to 1/4" 20 (SHSPIGOTM1)..... **5.28**
- Camera Screw Knob 1/4" 20 (SHVSCAM1) ..... **12.32**
- CP33 Multi-Purpose Mounting Cheese Plate (SHCP33) ..... **130.24**
- Mini Composite Shoulder Pad (SHPAD3) ..... **153.12**



### Target Shooter

Infinite adjustability and 3-points of contact for enhanced stability. Included Gorilla plate attaches to the bottom camera via 1/4"-20 mount, and is joined to the rest of the Shooter via a 15mm rod. The rig can be freed from the Gorilla plate by flipping the red lever. With the gunstock pressed against your body, you can adjust height and angle for the most comfortable fit, bringing the ergonomics and stability of a camcorder to your DSLR. A tripod plate can be installed to quickly move from handheld to tripod.



#ZAZDTS ..... **436.50**

### Striker

Infinite adjustability and 3-points of contact for enhanced stability. Gorilla plate attaches to the bottom of your camera via 1/4"-20 mount, and is joined to the rest of the Shooter via a 15mm rod. With the gunstock pressed against your body, you can adjust height and angle for the most comfortable fit. Also includes a handgrip for waist-level support.



#ZAZDSR ..... **779.00**

### Single Action Tripod Kit

Tripod only kit with a follow focus unit, that can be easily upgraded to a shoulder mounted rig. Works with any DSLR camera with or without battery grips. It is also adjustable in height. The Baseplate can be attached to your tripod plate using 1/4"-20 and 3/8 16" tripod plate screws. The Single Action Kit allows you to quickly release your camera from the rig by turning the red knob and then pulling up on your camera. The quick release plate stays mounted to your camera. It allows you to switch, using it as a camera or as a part of a rig. You can easily add the optional Z-Finder Pro.



#ZAZDSAB ..... **1467.00**

### Cross Fire (Black)

Brings together the handgrip, gunstock and adjustable 15mm rods of the Striker with the follow focus of the Single Action kit to deliver a versatile, lightweight support rig for any DSLR. Shoot smooth handheld video one moment, then mount the rig intact to your tripod using the included baseplate. The camera's quick release plate allows for easy removal, while the 0.8 pitch Zipgear can be cut and sized to match your lens of choice for precise, accurate follow focus.



#ZAZDCFB ..... **2137.50**

Zwiss Cage (ZAZDZWCB) ..... **972.00**

Newsman Baseplate Kit (ZAZNEWSB) ..... **1791.00**

Sling Shot DSLR Camera Rig (ZAZDSS) ..... **639.00**

Double Barrel Dual Handheld DSLR Rig (ZAZDDBB) ..... **3654.00**

### Bolt Action

This shoulder-mounted support system is a basic in-line dual handgrip system for DSLR cameras. It has a height-adjustable baseplate that will function with any DSLR, with or without a battery grip. Dual handgrip system helps reduce fatigue and keep the rig balanced. Works equally well on the right or left shoulder. Compatible with 15mm lightweight accessories.



#ZAZDBA ..... **1525.00**

### Fee-N-G DSLR ENG-Style Camera Support

Compact rig for ENG-style shooting with a DSLR. This streamlined, lightweight unit has a single handgrip rather than a dual system to save weight and space. The EVF Standard Mount will accept any electronic viewfinder, and it includes a kickstand that keeps the camera level when it's on the ground. A shorter DSLR handle at camera lens level gives you precisely balanced control when shooting in low mode. There's also a soft foam shoulder pad with 7" rods and a counterweight.



#ZAZDFNG ..... **1530.00**

### Fast Draw (Black)

Adjustable handgrip and shoulder pad provide stability and comfort, while the Z-Lite Double counterbalance weight keeps your rig from getting too front-heavy. And as the day grows long and your subject settles into one place, you can easily mount the entire rig onto a tripod using the DSLR baseplate.



#ZAZDFDB ..... **1395.00**

### Scorpion DSLR Shoulder Mount

Scorpion is designed to make shoulder-mounted DSLR video shooting easy and comfortable. It features a curved, form-fitting silicone gel shoulder pad that connects to the back of the baseplate with two 2" M/F rods. The rods screw into the back of the included DSLR baseplate and connect to the front of the shoulder pad via 15mm quick release ports, making it fast and easy to switch from shoulder mount to tripod and back. A ball joint allows the entire shoulder pad assembly to articulate in multiple directions so you can angle it to fit your body exactly the way you want it, for maximum comfort.



#ZAZDSP ..... **2430.00**

Scorpion Shoulder Assembly (ZAZDSPA) ..... **988.00**

### Z-EVF-1S EVF Snap

#### 3.2" High-Resolution Monitor

Compatible with the Z-finder series, displays images at a resolution up to 800 x 480. Attaches firmly to the HDMI port on the camera, allowing you to operate your DSLR with correct form factor for video.



#ZAZEVF1S (Z-EVF-1S EVF Snap) ..... **641.25**

#ZAZEVF1F (EVF Flip-Up Electronic View Finder) ..... **736.25**

### Z-Finder EVF 3.2" High-Resolution Monitor

Operate any camera with an HDMI port with the correct form factor for video. Gives you better resolution, gets your eye where it's most comfortable, enables low mode shooting, and shortens the camera package. Keep your electronic viewfinder in the back of a dolly or crane, detached from the rig for car shots, and more.



#ZAZFINDEREVF ..... **764.75**

#ZAZFINDEEVFP (Z-Finder EVF Pro) ..... **950.00**

### C300 Grip Handle Relocator

Attaches to a Zgrip to achieve distance-extended, chest-level handling of a Canon C300 Grip (which is a button-equipped hand controller that comes with the C300). A 24" cable built into the Relocator allows the C300 Grip to be used on a Zgrip, and allows it to be used from 24" farther than usual. (ZAZC3GR) ..... **356.25**



### Zacuto DSLR Video Rig Accessories

Gorilla Plate (ZAZGRB) ..... **65.55**

Gorilla Plate Adapter (ZAZGRPAPT) ..... **16.63**

1/4-20" Screw for DSLR Baseplate / Gorilla Plate (ZAZR262) ..... **11.40**

Z-ZHH Zonitor Lightweight Kit (ZAZZH15) ..... **366.30**

Z-LTE Z-Lite Counterbalance Weight (ZAZLTE) ..... **175.75**

Z-LTE-D Z-Lite Double (ZAZLTD) ..... **201.40**

Z-SP1 Shoulder Pad with 7" Rods (ZAZSP1) ..... **237.50**

DSLR Handle, Black (ZAZDSLH) ..... **237.50**

Z-ZWP Zwiss Plate (ZAZZWP) ..... **141.55**

EVF Gorilla Plate Bracket (ZAEGBP) ..... **228.00**

EVF Cheese Stick (ZAZECS) ..... **28.50**

EVF Quick Release Mount (ZAZEQMB) ..... **84.55**

Z-ERM EVF Rod Mount (ZAZERM) ..... **323.00**

Z-ESM EVF Standard Mount (ZAZESM) ..... **251.75**

EVF Tri-Mount Kit (ZAZETMB) ..... **323.00**

Cable Pincher (ZAZPNCH) ..... **123.50**

Z-OR Q-Release (ZAZOR) ..... **166.25**

HDMI Right Angle Adapter (ZAZRA) ..... **6.65**

Universal Baseplate Camera T-Slide (ZAZUB3CT3) ..... **18.05**

ZUD 1/4" 20, Black (ZAZUD1420B) ..... **41.80**

Z-1420 Screw 1/4-20 (ZAZ1420) ..... **11.40**

Z-ARM-ADPT Connection Adapter (ZAZARMADPT) ..... **16.50**

Shoulder Pad without Rods (ZAZSPD) ..... **171.00**

Zicro Coldshoe (ZAZZCS) ..... **71.25**

Z-GUN-S Gun Stock Chest Mount (ZAZGUNS) ..... **225.15**

Zgrip Glove (ZAZHGG1) ..... **23.28**

Horizontal Zwiss Plate (ZAZHZWP) ..... **232.75**

Ratcheting Lever for Zacuto Components (ZAZRL) ..... **9.26**

Ratcheting Lever Kit for Zacuto Components (ZAZRLK) ..... **36.10**

Top Handle for Blackmagic Cinema Camera (ZAZBMTH) ..... **199.50**

Top Handle for Lightweight Camera (ZAZCSH) ..... **228.00**

Sony-FS100 Top Handle (ZAZFSTH) ..... **228.00**

Zgrip Handle with C300 Grip Relocator (ZAZHGC3GR) ..... **551.00**

800-947-1186 | 212-444-6686

Shoulder & Hand Mounted Support



**EgripZ** Handheld Camera Support

Flexible, handheld support, adapts into virtually any position or configuration, enhancing and facilitating smooth camera operation. Attaches easily to a monopod or other support base for additional stability, and can serve as a comfortable camera shoulder support.

#ANEGRIPZ ..... **77.95**



**Stasis Flex** Shoulder Mount Stabilizer

has an infinitely adjustable mechanism which allows users to position the camera into virtually any shooting position- in/out forward/back or up/down. Can be a platform for mounting Gold Mount, ElipZ or other Anton Bauer accessories.

#ANSF ..... **222.46**



**Camera Comfort Cushion**

Helps eliminate common upper extremity disorders and musculoskeletal injuries associated with carrying video cameras. Works with shoulder mounted MiniDV to broadcast sized cameras. (ALCC)...**59.95**



**Scorpion EX** Video Camera Stabilizing Handle

Made from a lightweight composite material with polymer grip, the Scorpion EX provides a comfortable and solid platform, and offers stable support dampening jerky movements like a camera stabilizer or Jib arm.

Includes an accessory shoe and multiple shoes can be used. Featuring 1/4"-20 threaded feet, can be fitted to an optional cheese plate facilitating fast switching between handheld and tripod-mounted shots. (CAEX) ..... **64.95**



- Scorpion EX Pro Kit (CAKEX) ..... **229.95**
- Starter Kit (CAKT1) ..... **99.95**
- Scorpion Accessory Shoe (CAAC) ..... **19.95**
- Flash / Cold Shoe 1/4"-20 Converter (CA142) ..... **19.95**
- PC Accessory Kit (CAAK1) ..... **49.95**
- Scorpion EX Cheese Plate (CACPL) ..... **49.95**
- Mounting Knob (CAKN) ..... **6.95**
- Short Bar Headrest Camera Mount (CRC1) ..... **44.95**
- Scorpion Lockout Kit (CALK) ..... **39.95**
- Scorpion Universal Stabilizing Camera Handle (CACHU) ..... **29.95**



**Steady Stick Compact**

Belt-mounted support arm shifts camera weight from shoulder to torso, leaving your hands free to direct the movement of the camera. Compatible with any compact camcorder that features a 1/4"-20 tripod socket.



**Shoulder Mount Stabilizer**

Lightweight stabilizer featuring 2-point



stabilization using the back and chest. It has a spring-loaded, locking pivot point, and is easily adjustable, with high-density foam-lined shoulder and chest pads. The weight of your gear is distributed onto your back and chest, leaving your hands free. You get smoother looking video and reduced muscle fatigue. A 1.5" strap is provided to clip onto the unit and across the body for further safety and stability when in use.

#DISMS ..... **79.95**



**Hands-free Video Stabilizer**

Consists of a bracket with padded shoulder mount, a spring chest harness, heavy-duty strap and two adjustable platforms to accommodate large camcorders and DSLRs with telephoto lenses, and small camcorders and DSLRs with short tele lenses. (DOVS).....**40.65**



**GL GVCSMK** Video Shoulder Mount

Shoulder support system that allows you to attach camera accessories with the help of adjustable 15mm rods. With the non-slip foam grips, an adjustable shoulder pad, and a counter weight, the mount ensures stable and efficient shooting. Use to attach matte box, follow focus, and monitors.

#GEGLGVCSMK ..... **923.00**



**HD Camera Brace**

for Cameras up to 13 lbs.

Puts a DSLR camera or small to mid-size camcorder on your shoulder and provides two comfortable hand grips so you can capture steady, smooth handheld shots with ease. The rig features a 3/4"-thick pad for your shoulder and fully adjustable components - you can tweak the positioning of both hand grips, and adjust the distance from the camcorder's LCD to your eye. The shoulder brace features several 1/4"-20 mounting holes on both its top and rear, presenting a perfect platform for mounting accessories.

#HAHDB ..... **Call or Log-on**



**WristShot**

DSLR Support System

Capable of supporting any DSLR, WristShot combines strap-on pads with an articulating arm that can be adjusted on 5 axes, allowing you to lock the camera into position for optimal stability and comfort.

#HOHWS1 ..... **69.99**



**HunterCam CLAMP-A-CAM MINI**

Self Clamping Camera Support

Portable camera mount with pan and tilt head with quick release which can be attached to objects 1/2 to 2" thick in any position. Constructed of weather-resistant anodized aluminum with stainless steel fasteners and Teflon bushings. (HUCACM)..... **89.95**



**ikan Flyweight Camcorder Shoulder Rig**

Lightweight system for midsize camcorders with interchangeable pad that allows you to rest the rig on your chest for stability. Large EV2 baseplate can be adjusted laterally and vertically (great for offset shots) and the integrated tripod mounting plate accepts quick-release or larger wedge-style plates. Enhanced adjustable tension knobs safely secure your camcorder. Heavy-duty non-slip rubberized grips. Includes cheese plate and Cheese Stick JR mounting accessories. (IKEFLWCAM)..... **449.00**



**ikan Recoil**

DSLR & Camcorder Shoulder Support

Adjustable chest brace for a comfortable fit over the body. Mounting platforms for video or still camera. Foam handgrip adds stability and control when shooting video with a DSLR. Folds up for easy storage.

IKELERECOIL ..... **89.00**



**Manfrotto Modo Steady 585**

Camera Support

Handheld camera stabilizing device. It works with small cameras and offers weighted camera stabilizing or shoulder support balance for moving camera applications. (MA5851) ..... **Call or Log-on**



**Manfrotto Fig Rig** Handheld Stabilizer System

Unique design absorb handheld shocks and extraneous movement. Padded handgrip for a comfortable, secure grip. Supplied cable clips keep cables out of your way. Includes a 501PL sliding quick-release plate.

#MA595B ..... **274.90**

#MA595BAG (Fitted Soft Case for Fig Rig) ..... **70.00**

#MA595CLA (Fig Rig Clamp) ..... **50.95**



**Polaroid Video Mount**

Adjustable chest/shoulder-brace system employs a spring-tension design for its center column. The chest and shoulder contact points are padded with thick foam for comfort. Adjustable heavy-duty nylon strap hugs the rig to your body, so hands free to handle zoom, focus, lighting, etc. (POPLVM) ..... **34.99**



**MOV CAM**

**Lightweight Support for Sony NEX-FS700**

Multi-component shoulder support consisting of a base plate with two 8" 15mm rods, a height spacer atop the plate, rosettes for mounting optional rosette hand grips, and a rubber shoulder pad. The rods can be used to support a mattebox and follow focus, and the spacer atop the plate features two screw-holes on its side into which you can attach a Movcam FS700 Side Bracket with an FS700 Top Handle. This combination will wrap around the camera and provide you with numerous 1/4" and 3/8" threads, with a rod clamp and with a cold shoe. (MOLWSSFS700)..... **632.00**



**NEX-FS700 Shoulder Support Kit**

Lightweight, easy-to-set-up and easy-to-use support for the Sony NEX-FS700 camera. A baseplate, side bracket and top handle make up the kit and together deliver a terrific handheld support. A mini cheeseplate (part of the top handle) and a side-bracket are connected together in this kit to create a half-sided cage, which both protects the camera and provides many mounting threads for accessories to be attached to. In Black (MOV30317B) or Gray (MOV30317)..... **1244.00**



**ultraCage | blue for Canon C300**

Designed specifically for the Canon EOS C300, the ultraCage is lightweight and form fitting enough to be completely unobtrusive – all camera features can be accessed without interference. The C300's removable handgrip can even be attached without removing the camera from the cage. Can be easily configured in studio and handheld setups, and it's nearly infinitely expandable. Compatible with an optional Redrock Micro power Pack that powers not only the C300 camera, but up to 2 additional camera-top accessories such as monitor, wireless follow focus, external recorders, or audio systems. #RE31010100..... **550.00**



**ultraCage | blue 15mm Cinema Bundle for Canon EOS C300**

System starts with the ultraCage I blue, providing the core baseplate and camera cage. The ultraCage maximizes stability, and supplies top and bottom rails, a tripod attachment, and multiple points for mounting accessories. The rear chassis cage delivers a robust top- and bottom-rail setup with 48 additional mounting points, so all of your accessories such as camera-top monitors, audio boxes, external recorders, microphones, etc. can be secured on your rig. The ultraCage I blue top handle can be configured for single, single with double-clamp, and double top handle to strike a perfect balance between strength and light weight. #RE81010104..... **1586.75**



**SHAPE**

**Mountain 5100 Camera Support**

Ideal solution for shooting in tight situations with a minimum of gear. The system has three components. The Power-Grip TL6AMB vacuum cup has a 7.5 lb capacity and will cling to any clean, reasonably flat surface. The articulating arm provides camera angle options while the Manfrotto 143BKT camera bracket offers flexibility in movement and 1/4"-20 camera mounting screw. (SHM05100)..... **175.12**



**Blackmagic Handheld Cage Kit**

Lightweight rig designed for the Blackmagic Cinema Camera. Ideal for handheld and tripod work, the cage is made from CNC-machined aluminum and weighs just 2.8 lb. It includes an adjustable top handle with patented 360° push-button technology. Both the cage and the top handle are threaded with multiple 1/4"-20 and 3/8"-16 screw mounts for mounting accessories. The bottom of the cage has screw mounts for attaching a tripod plate and a pocket for camera ventilation. #SHBMCCHH..... **540.32**



**Composite Grip**

Made of aluminum, CNC machined, and powder-coated with wrinkle finish, the grip features adjustable camera platform height, quick handle with 360° rotation, push button operation and backpad for stability and comfort. Includes Paparazzi Riser. (SHCOMPGRIP)..... **694.32**  
#SHCOMPOF3 (COMPOSITE F3)..... **679.00**  
V-Lock Quick-Release Baseplate Kit (SHBP7000)..... **1987.92**  
Composite C300 Camera Support Bundle (SHCC300)..... **1715.12**



**STEDI-STOCK**

**SSSB Stedi-Stock Shoulder Brace**

Working much like a rifle stock, it mounts the camera or optic device on a 1/4-20 screw, offering a stable platform for viewing or recording. #ST801SSSB..... **Call or Log-on**



**witronix HDV-PRO Shoulder Support**

Made from machined, aircraft aluminum and is fully adjustable. Swinging arm and flexible shoulder brace provide more versatility when shooting. Folds down to fit most camera bags. (SWHDVPRO)..... **248.00**  
#SWHDVPRO (with V-mount Plate)..... **380.00**



**Mini Rover Camera Grip**

Sturdy all-metal L-shaped bracket, the Mini-Rover is ideal for mounting accessories such as mics or lights in the shoe above the cushioned handgrip. Padded camera platform has anti-twist pins to keep the camera stable, plus standard tripod mounting holes. (MIRO3)..... **69.95**



**VariZoom**

**DV Media Rig Pro Support System**

Articulating weight balance system for camcorders up to 7 lbs. Spring-loaded abdominal suspension pod and swiveling shoulder arch add comfort and professionalism to any shoot. Full tilt, side-to-side, and front-to-back axis capabilities. Rotating mount for lights, monitors, mics and more. (NAVZDVMR)..... **569.95**



**VZ-LSP Shoulder Mount Support System**

Crafted with precision from machined aluminum, this tough, lightweight shoulder brace has 10 adjustable fittings. The VZ-LSP is for camcorders weighing up to 8 pounds. #NAVZLSP (VZ-LSP w/abdominal brace)..... **428.95**  
VZ-DVTRAVELER (NAVZDVTRAVEL)..... **305.59**



**VideoPerch**

Attaches to just about any solid surface up to 1.5" thick. Leave your heavy, expensive tripod behind and use this unique arm mount to set up your camcorder on a tree, a car window, a golf bag, or even the back of a chair. (MAMKVPO6)..... **69.95**



**VIDEO INNOVATORS**

**S-800 Shoulder Mount Support**

This fully adjustable shoulder rest fits all consumer/prosumer camcorders to keep your shots steady while reducing fatigue. #VIS800Q (S-800 Standard Shoulder Rest)..... **59.95**  
#VIS800P (S-800P Pro Shoulder Rest)..... **69.99**  
#VIS800SP (S-800SP Super Pro Shoulder Rest)..... **92.00**  
ES-800SP Extended shoulder rest (VES800SP)..... **34.95**



**C300 Target Shooter Camera Rig**

Easily assembled lightweight stabilization rig for run and gun shooting with a Canon C300. Includes a Gorilla baseplate that attaches to your camera with 3/8"-16 and 1/4"-20 screws and has 15mm threaded holes for mounting a follow focus, lens support or other accessories in front of the camera. A tripod plate can be installed to quickly move from handheld to tripod. #ZAZCTS..... **498.75**  
Stinger for Blackmagic Cinema Camera (ZAZBMST)..... **1567.50**  
C300 Stinger Shoulder Mounted Rig (ZAZCSTG)..... **1472.50**  
Recoil Rig for C300/Scarlet/Epic Cameras (ZAZCRL)..... **1306.25**  
Recoil Lite for C300/Scarlet/Epic Cameras (ZAZCRLLT)..... **532.00**



**Mighty-Wondercam Classic Shoulder Pod (MICQ)..... 179.95**  
**Novoflex Chest/shoulder pod (NOCSP)..... Log-on**  
**Sima Mini Video Prop Chest Support (SISVFP3)..... 17.49**  
**Smith-Victor CS-1 Camcorder stabilizer (SMCS1)..... 59.00**  
**The Pod Black Pod Camera Platform (THBP)..... 44.98**  
**Zacuto iPhone Handgrip System (ZAZIPS)..... 114.95**  
**Zacuto Zgrip iPhone Jr. (ZAZZGIPJ)..... 65.55**

800-947-1186 | 212-444-6686

**Easyrig**

**Mini Strong**

Stabilizing Camera Support

Cost effective system, it supports 9 to 13 lbs of camera weight, relieves the strain of that weight from your arms, and leaves you only with the job of maneuvering the camera in desired directions. Includes a protective transport bag that fits not only the Easyrig but also your camera and many of its accessories.

#EAERMS..... **1339.00**



**GLIDECAM**

**XR Series Handheld Camera Stabilizers**

Offset, foam cushioned, handle grip is attached to a free floating, three-axis gimbal isolating your hand's unwanted motions from the camera. Quickly adjust the camera's horizontal balance via the dynamic camera balance platform; and the camera's vertical balance by varying the amount of counterweight disks, or by changing the length of the no-tools telescoping Central Post. When balanced properly the camera floats, ready for you to move into action.



**XR-1000:** for cameras from 1-3 lbs (GLXR1000)..... **259.00**  
**XR-2000:** for cameras from 2-6 lbs (GLXR2000)..... **359.00**  
**XR-4000:** for cameras from 4-10 lbs (GLXR4000)..... **424.00**

**GLIDECAM**

**HD1000/2000/4000**

Camera Stabilization Systems

Transform camera footage into hypnotically smooth, professional-looking images. They feature precision 3-axis gimbal, foam padded handle grip, integrated quick-release camera plate, adjustable dynamic balance and inertial control base platform.



#GLHD1000 (cameras up to 3 lbs)..... **Call or Log-on**  
 #GLHD2000 (cameras from 2-6 lbs)..... **Call or Log-on**  
 #GLHD4000 (cameras from 4-10 lbs)..... **Call or Log-on**  
 #GLGCGB (Forearm Brace)..... **Call or Log-on**

**GLIDECAM**

**Smooth Shooter**

Designed to work with the 2000 and 4000 Pro, lets you glide effortlessly over rough terrain to achieve smooth, track-like footage. Includes vest, Dyna-Elastic arm, stainless steel arm post, steel weight plates and docking bracket. (GLSS)..... **Log-on**



**GLIDECAM X-10**

Professional stabilization system designed for cameras weighing up to 6 lbs. when used with the 2000 Pro, or 4 to 10 lbs. when used with the 4000 Pro. Support arm can be boomed up and down, as well as pivoted in and out, and side-to-side. Support vest is lightweight, comfortable and can be adjusted to fit a wide range of users. (GLX10)..... **Log-on**



**Blackbird Camera Stabilizer**

Allows easy leveling, balancing and positioning of DSLRs and camcorders up to 8 lbs. Includes a camera

stage/chassis with support arm, mounting plate, locating pin, gimbal and extender, T-bar assembly with two horizontal bars and counterweights. (#CABBB)..... **469.95**

Case for Blackbird (CACBB)..... **64.95**  
 Resting Stand for Blackbird (CARSBB)..... **64.95**  
 Tripod Adapter for Blackbird (CATABB)..... **24.95**  
 Blackbird Kit (CABBK)..... **669.95**



**SteadyTracker UltraLite**

Lightweight stabilization system for camcorders up to 3 lbs. Features panning control with the ability to upgrade with monitors and low-mode accessories. For heavier loads, the SteadyTracker Xtreme handles camcorders up to 8lbs.

#COSTUL (SteadyTracker UltraLite)..... **193.95**  
 #COSTX (SteadyTracker Xtreme)..... **289.95**



**SteadyVid PRO**

Supports a DV or DSLR camera weighing up to 5 lb. with one-touch and precision adjustments on all joints and axes. Features aluminum construction, adjustable mounting plate, comfortable grip handle, super-smooth gimbal, and a spirit level. Includes two removable weights plus a main counterweight. (OTSVPRO)..... **149.95**



SteadyVid EX Stabilizer (OPTSVEX)..... **59.95**

**STEADICAM**

**Smoother**

Takes the same technology from expensive Hollywood Steadicam rigs and shrinks it down. Simply snap your iPhone or iPod Touch into the specially designed mount, grip the handle, and float your camera smoothly and effortlessly through the air.

For iPhone 4 (STSIP4), iPod Touch (STSIT), GoPro HERO (STSGPM)..... **149.95**



**STEADICAM**

**Merlin 2 Handheld Stabilizer**

Lets you go where the scene takes you – up or down steps, indoors and out, through crowds – almost without limitation. The Merlin 2 weighs just 1.4 lb and can handle cameras up to 5 lb in weight. It gives you precise, elegant control for dramatic, professional you-are-there footage. The quick-release mount lets you instantly switch between your stabilizer and any tripod. This system utilizes a metal gimbal for smooth camera movement.

#STM2S..... **649.00**



**STEADICAM Pilot**

Camera Stabilizer System

State-of-the-art system lets you achieve smooth-as-silk camera movement without the need for a dolly, jib or crane. Accommodating cameras from 2 to 10 lbs, the two-section, articulated design includes a silky-smooth Iso-Elastic arm, ultra low profile vest, lightweight sled with CarbonLite expandable post, 5.8" 16:9 color LCD monitor and low-mass gimbal.



#STPAA (with AA battery mount)..... **3795.00**  
 #STPAB (with Anton Bauer battery mount)..... **3795.00**  
 #STPVL (with V-Lock battery mount)..... **3795.00**

**STEADICAM Zephyr**

Camera Stabilizer System

No-tools adjustable Iso-elastic™ arm supports up to 20 lbs. HD ready with connector rich base and stage. "On the fly" weight adjustment. Dual axis vernier adjustable stage. Unparalleled inertial control and dynamically adjustable base. Facilitates quick setup via a single knob rod-release feature.



#STZABBSVHDM (with HD monitor and AB mount)..... **11,325.00**  
 #STZABBCVHDM (HD monitor, AB mount, compact vest)..... **11,515.00**  
 #STZVMCVHDM (HD monitor, V-lock, compact vest)..... **10,495.00**  
 #STZVMSVHDM (HD monitor, V-lock, stand, vest)..... **11,325.00**

**STABILIZER ACCESSORIES**

**Anton Bauer**

FGM-S Gold Mount with Cable (ANFGMS)..... **159.00**

**Glidecam**

Docking Bracket for Stabilizers (GLGLHDSDB)..... **94.99**  
 BP-L4P Battery Pack (GLBPL4P)..... **Log-on**  
 L4-PRO-BKT Monitor Mounting Bracket (GLL4PROBKT)..... **12.95**  
 Low Mode FX Kit for the 2000/4000 (GLLMFXK)..... **229.00**  
 Body-Pod (GLGCBP)..... **Log-on**  
 Forearm Brace (GLGCFB)..... **Log-on**  
 L4-PRO 4" Active Matrix TFT LCD Monitor (GLL4P)..... **399.00**  
 Camera Weight Plate (GLGLCWV)..... **14.95**

**Porta Brace**

Case for HD2000/HD400 and camera (POLR3BGLCC)..... **169.95**

**Steadicam**

iPod Touch Smoother Mount (STMAIPT)..... **24.95**  
 iPhone 4 Smoother Mount (STMAIP4)..... **24.95**  
 GoPro HD Hero & HD Hero2 Smoother Mount (STMGP)..... **23.50**  
 SteadiSTAND for Merlin (STSS)..... **165.00**  
 Replacement Camera Mounting Screw for Merlin (STCMS)..... **7.95**  
 Replacement Locating Pin for Merlin (STLP)..... **3.95**  
 Backpack for Merlin or Pilot (STBSPM)..... **385.00**  
 Merlin-ARMVESTPK Upgrade Kit (STMAVQ)..... **1495.00**  
 Docking Bracket for Merlin (STDBZ)..... **39.95**  
 Start Balance Weight with O-Ring for Merlin (STSW)..... **25.00**  
 Tripod Adapter Plate for Merlin (STAP)..... **19.95**  
 Custom Fitted Travel Case for Merlin (STCM)..... **99.95**  
 Middle Balance Weight with O-Ring for Merlin (STMW)..... **25.00**  
 Steadicam Tool Kit Bag (STTKB)..... **19.95**  
 Mini Low-Mode F Bracket (STLMBFM)..... **199.00**  
 Display Unit - Upright Stand for Steadicam (STMDU)..... **84.95**  
 Camera Plate for Merlin 2 Camera Stabilizer (STDPM2)..... **84.95**  
 801-7920-06 End Weight with O-Ring (STEW)..... **25.00**  
 Merlin Vest Buckle & Belt Upgrade Kit (STMPV)..... **49.95**  
 FFR-000014 Sand Bag (STSB)..... **24.95**  
 Stage Weight Bracket (Merlin) (STSWB)..... **85.95**

PRO VIDEO TRIPOD HEADS



Fluid Heads

The FM18 compact fluid head with quick release features independent tilt & pan adjustment/locks.

Model	Capacity	Height	Weight	SKU	Price
FM18	18 lbs.	NA	4 lbs.	DAFM18	99.95



GITZO Fluid Heads

The extremely compact, low profile G2180 fluid head with quick-release features a fully adjustable counter balance system. The G2380 fluid effect video head with quick-release provides exceptionally smooth pans and tilts.

Model	Capacity	Height	Weight	SKU	Price
G2180	12 lbs.	4"	2 lbs.	GIG2180	249.99
G2380	18 lbs.	NA	4 lbs.	GIG2380	299.99



Manfrotto Video Fluid Heads

Model	Capacity	Height	Weight	SKU	Price
128LP	8.8 lbs.	4.3"	2.2 lbs.	MA128LP	Log-on
128RC	8.8 lbs.	4.5"	2.2 lbs.	MA128RC	Log-on
501HDV	13.2 lbs.	4.5"	3.5 lbs.	MA501HDV	177.90
502HD (A)	8.8 lbs.	5.9"	4 lbs.	MAMVH502A	194.99
502HD (AH)	8.8 lbs.	5.1"	3.5 lbs.	MAMVH502AH	169.95
504HD	16.5 lbs.	6.1"	6.4 lbs.	MA504HD	339.95
509HD	29 lbs.	7"	8.4 lbs.	MA509HD	799.90
526	35.3 lbs.	5.9"	7.9 lbs.	MA526	1019.95
701HDV	9.5 lbs.	3.7"	1.8 lbs.	MA701HDV	129.99
700RC2	5.5 lbs.	3.8"	1.1 lbs.	MA700RC2	Log-on



sachtler Fluid Heads

The 0707 FSB-8 fluid head provides a 75mm ball, 10-stage counterbalance, as well as five steps of drag (plus 0) for both tilt and pan. The 1006 DV-10 SB features 12 counterbalance presets, a self-illuminated touch bubble for leveling with the 100mm half-ball base, plus 5-step horizontal and vertical drag presets. The 1205 DV-12SB fluid head features a 12-step counterbalance system with a 2.8" sliding plate for perfect balance, and 5 steps of drag plus zero in both axes for whip pans.

Model	Capacity	Height	Weight	SKU	Price
0307	8.8 lbs.	6.4"	4.2 lbs.	SAFSB4	729.80
0405	13.2 lbs.	—	4.7 lbs.	SAFSB6T	1295.60
0407	13.2 lbs.	—	4.4 lbs.	SAFSB6	1295.60
0705	20 lbs.	6.4"	4.7 lbs.	SAFSB8T	1681.00
0707	20 lbs.	—	4.7 lbs.	SAFSB8	1681.00
1006	26 lbs.	7"	5.9 lbs.	SADV10SB100	2443.60
1205	31 lbs.	7"	6 lbs.	SADV12SB	3062.70
Video 18 S1	40 lbs.	6.8"	7.3 lbs.	SAV18S1	4768.00



Vinten Fluid Heads

Model	Capacity	Height	Weight	SKU	Price
Vision Blue	11 lbs.	4.8"	5.3 lbs.	VIV40920001	803.60
Vision Blue 5	26 lbs.	4.9"	5.3 lbs.	VIVB5	1789.25
Vision 8AS	27.6 lbs.	3.6"	6.8 lbs.	VIV8AS	3075.00



ADDITIONAL TRIPOD HEADS

Benro S2 Video Head: 5.56 lb. capacity, weighs 0.8 lbs. (BES2).....	76.00
Benro S6 Video Head: 13.2 lb. capacity, weighs 2.6 lbs. (BES6).....	160.00
Cartoni Focus HD Video Tripod Head: 26 lb. capacity, weighs 5 lbs. (CAF125).....	974.95
Cinevate Dromos Hi Hat: Accepts 100mm ball natively and 75mm with adapter (CIDHH).....	399.99
Daiwa / Slik Digital Balance Pro Fluid Pan Head with Quick Release (DA618665).....	189.95
Libec RH25R Pan and Tilt Fluid Head: 13 lb. capacity, weighs 5.3 lbs. 75mm bowl (LIRH25R)....	624.00
Libec RH35R Pan and Tilt Fluid Head: 20 lb. capacity, weighs 5.7 lbs. 75mm bowl (LIRH35R)....	939.95
Miller 1034 Compass15 Fluid Head: 20 lb. capacity, weighs 5.5 lbs. 75mm bowl (M11034).....	1250.95
Miller 1022 Arrow 25 Fluid Head: 30 lb. capacity, weighs 6.7 lbs. 100mm bowl (MIA25FH).....	2691.00

PRO VIDEO TRIPOD LEGS



Manfrotto Single Leg Tripods

The versatile 755XB and 755CX3 MDeVe tripods feature a video-ready leveling system fitted directly to the top of the center column. The aluminum 755XB has a removable center column, while the 755CX3 has carbon fiber legs with an aluminum column and magnesium/aluminum castings.



Model	Load Capacity	Leg Sections	Maximum Height	Folded Length	Weight	SKU	Price
117B	32.6 lbs.	2	67.5"	37"	10 lbs.	MA117B	254.95
132XNB	66 lbs.	2	NA	NA	NA	MA132XNB	409.89
528XB	110 lbs.	2	58.3"	40"	16.3 lbs.	MA528XB	550.00
755XB	15.4 lbs.	3	65"	25"	5.5 lbs.	MA755XB	249.90
755CX3	15.4 lbs.	3	54.7"	25"	4.3 lbs.	MA755CX3	498.00

Manfrotto 529B Hi-Hat with 100mm half bowl

Facilitates shots from the lowest possible position. Rubber padded feet protect delicate surfaces. Supports up to 44 lbs. (MA529B).....



Manfrotto M-Pro Single Leg Tripods

Featuring high-performance carbon fiber tubes, and lightweight magnesium die castings.

Model	Load Capacity	Leg Sections	Maximum Height	Folded Length	Weight	SKU	Price
535	44 lbs.	3	67"	28.7"	5.1 lbs.	MA535	549.89
536	55.1 lbs.	4	79.2"	27.9"	7.2 lbs.	MA536	599.99



Manfrotto Pro Twin Leg Tripods

These pro tripods feature aluminium twin-strut legs with adjustable locking levers.

Model	Load Capacity	Leg Sections	Maximum Height	Folded Length	Weight	SKU	Price
545B	55 lbs.	3	60.3"	27.2"	7.7 lbs.	MA545B	414.90
546B	44 lbs.	3	60.6"	27.2"	7.7 lbs.	MA546B	374.99
546GB	44 lbs.	3	62.4"	27.2"	7.7 lbs.	MA546GB	449.00
MVT502AM	33.1 lbs.	3	56.5"	24.2"	4.3 lbs.	MAMVT502AM	246.95

MILLER Solo Carbon Fiber Tripods

Model	Head	Load Capacity	Leg Sections	Maximum Height	Folded Length	Weight	SKU	Price
1501	—	44 lbs.	3	63.5"	27.3"	5.5 lbs.	M1501	687.70
1505	—	66 lbs.	4	73.6"	25.9"	6.8 lbs.	M1505	939.99
1630	—	44 lbs.	3	63.5"	27.6"	6.6 lbs.	M1630	449.95
M12001	—	44 lbs.	4	73.6"	27.3"	6.6 lbs.	M12001	1098.50

ADDITIONAL TRIPODS LEGS

Alan Gordon Enterprises 1004-HIHAT-75 Hi-Hat (ALHH75B).....	148.50
Alan Gordon Enterprises 1004-HIHAT-100 Hi-Hat (ALHH100B).....	169.95
Alan Gordon Enterprises 1004-HIHAT-150 Hi-Hat (ALHH150B).....	169.95
Birns & Sawyer Hi-Hat with 75mm Bowl (B175DVB).....	169.95
Birns & Sawyer Hi-Hat with 100mm Bowl (B1100B).....	144.95
Birns & Sawyer Hi-Hat with 150mm Bowl (B1150B).....	179.95
Davis & Sanford ProVista 100 2-Stage Aluminum Tripod with 100mm Bowl (DAPV100).....	274.95
Induro DR Hi-Hat Tripod Set (100mm Bowl) (INLFB100S).....	279.00
Induro DR Hi-Hat Tripod Set (75mm Bowl) (INLFB75S).....	249.00
Libec RT30B 2-Stage Aluminum Tripod (LIRT30B).....	216.00
OConnor 45A-002 5 1/2" Hi-Hat with 100mm Bowl (OCHH100).....	222.70
Sachtler CF-100ENG HD 2CF Carbon Fiber HD Tripod Legs (SACF100HD2CF).....	1918.80
Sachtler 4183 DA 75 Tripod with 75mm bowl (SADA75L).....	385.40
Sachtler 4589 Speed Lock 75 Carbon Fiber Tripod with Spreader (SASL75CFMLS).....	1189.00
Sachtler CF-100ENG 2CF Carbon Fiber Tripod Legs (SACF1002CF).....	1681.00
Sachtler 4588 Speed Lock 75 CF Tripod w/ 75mm Bowl (SASL75CF).....	992.20
Vinten 3772-3 ENG Carbon Fiber Tripod Legs (M37723).....	1270.75
Vinten 3776-3 ENG Carbon Fiber Tripod Legs (M37763).....	1217.70
Vinten 3821-3 Pozi-Loc Aluminum Tripod Legs (M38213).....	922.25

PRO VIDEO TRIPOD SYSTEMS

**Acebil**

<b>HM-20:</b> 2-stage system with middle spreader. Supports 6.6 lbs (ACHM20).....	<b>139.00</b>
<b>i-605DX:</b> 2-stage system with middle brace & fluid head. Supports 6.6 lbs (ACI605DX) .....	<b>139.95</b>
<b>i-705DX:</b> With middle brace, fluid head and S-9 case. Supports 9 lbs (ACI705DX) .....	<b>209.95</b>
<b>i-705DX</b> Prosumer Tripod System with RMC-1DV Video (ACI705PK1DV).....	<b>287.95</b>

**Benro**

Video Tripod Kit (BEAD71FK5).....	<b>195.00</b>
-----------------------------------	---------------

**Bescor**

TH-770 High Performance Tripod System (BETH70).....	<b>119.00</b>
---	---------------

**Cartoni**

<b>HIDV1</b> Video Tripod System (CAHIDV).....	<b>1044.95</b>
<b>H102</b> HiDV2 Video Tripod System (CAHIDV2) .....	<b>1289.95</b>
<b>F126</b> FocusHD System (CAF126).....	<b>1299.00</b>
<b>F127</b> FocusHD AL 2/ML System (CAF127).....	<b>1424.95</b>

**Daiwa / Slik**

<b>DST-3</b> Lightweight 2-Stage Tripod System (DADST3) .....	<b>259.00</b>
<b>DST-43</b> Broadcast Tripod with Fluid Video Head (DADST43).....	<b>299.90</b>
<b>DST-73</b> Broadcast Tripod with Fluid Video Head (DADST73) .....	<b>449.95</b>
<b>DST-103</b> Broadcast Tripod with Fluid Video Head (DADST103) .....	<b>799.95</b>

**Davis & Sanford**

<b>Dollypod JR</b> with FM18 fluid effect head. Supports 18 lbs (DADPFM18) .....	<b>Call or Log-on</b>
<b>Provista 7518 Tripod</b> with FM18 head. Supports 18 lbs (DAPVT75).....	<b>189.00</b>
<b>ProVista Tripod</b> with FM18 head. Supports 18 lbs (DAPVTFM18).....	<b>163.99</b>
<b>ProVista Grounder</b> with FM18 head. Supports 18 lbs (DAPVTQ).....	<b>164.95</b>
<b>ProVista 6510 Tripod</b> with V10 fluid head, 65mm ball leveler. Supports 10 lbs (DAPVTV10).....	<b>109.88</b>
<b>MagnumXG13</b> Grounder Tripod with FX13 Head (DAMXG13).....	<b>159.00</b>

**Dracast**

DVT-17 Video Tripod with Fluid Head (DRDVT17).....	<b>177.95</b>
DVT Pro -1 Video Tripod with Fluid Head (DRDVTPRO1).....	<b>209.00</b>

**Libec**

<b>LX5</b> Tripod With Pan and Tilt Fluid Head and Floor Spreader (LILX5F) .....	<b>380.90</b>
<b>LX5 M</b> Tripod With Pan and Tilt Fluid Head and Mid-Level Spreader (LILX5M) .....	<b>380.90</b>
<b>LX7</b> Tripod With Pan and Tilt Fluid Head and Floor Spreader (LILX7F) .....	<b>509.95</b>
<b>LX7 M</b> Tripod With Pan and Tilt Fluid Head and Mid-Level Spreader (LILX7M).....	<b>509.95</b>
<b>TH-2000</b> Video Tripod with quick release plate and two pan arms (LITH2000) .....	<b>620.00</b>
<b>TH-650DV</b> Tripod with mid-level brace, fluid head, pan handle & soft case (LITH650DV).....	<b>184.95</b>
<b>TH-950DV</b> 2-stage aluminum tripod with head, pan handle & carrying case (LITH950DV).....	<b>298.00</b>

**Manfrotto**

055CXV3 Tripod with 701HDV Head Kit (MA701HDV055C).....	<b>Call or Log-on</b>
MVH502A Pro Fluid Video Head with MVT502AM Telescoping Tripod (MAMK502ATAM) .....	<b>323.95</b>
MVH502A head with 546B tripod with carry bag (MAMMH502A546).....	<b>439.00</b>
MVH502A head with MVT502AM tripod and carrying bag (MAMMK502AM) .....	<b>329.99</b>
Midi CF System: 504HD head with 535 2-stage carbon fiber tripod (MA504HD535K).....	<b>849.95</b>
Midi CF System: 504HD head with 536 3-stage carbon fiber tripod (MA504HD536K).....	<b>1049.95</b>
Midi Twin System: 504HD head with 546B 2-stage aluminum tripod (MA504HD546BK) .....	<b>669.00</b>
Midi Twin System: 504HD head with 546B 2-stage aluminum tripod (MA504HD546GB).....	<b>739.95</b>
509HD head with 536 carbon fiber tripod and tripod bag (MA509HD536K).....	<b>1599.00</b>
509HD head with 545B aluminum tripod, mid-spreader, bag (MA509HD545B).....	<b>1299.95</b>
509HD w/545GB aluminum tripod, ground spreader, bag (MA509HD545G).....	<b>1399.95</b>
526 fluid head with 545B tripod, mid-spreader, bag (MA526545BK) .....	<b>1549.95</b>
526 fluid head with 545GB tripod, ground spreader, bag (MA526545GBK) .....	<b>1699.00</b>
545B Professional tripod legs with mid-level spreader (MA545B).....	<b>414.90</b>
701HDV fluid head, 055XB tripod legs and soft case (MA701HD055XB).....	<b>Call or Log-on</b>
701HDV fluid head and 190XV View Green tripod (MA701HD190XV).....	<b>Call or Log-on</b>
701HDV fluid head with 755XB tripod and tripod bag (MA701HDV755X).....	<b>398.49</b>
MVH502A Pro video fluid head with 535 CF tripod and padded bag (MAMMK502C).....	<b>659.99</b>

**Miller**

<b>DS-10</b> Aluminum Tripod System (MIDS10AGKQ).....	<b>1399.00</b>
<b>DS-10</b> DV Fluid Head with Solo Aluminum Tripod (MIDS10SDVAT).....	<b>1029.95</b>
<b>DS-20</b> Aluminum Tripod System (MIDS20E0GK) .....	<b>1449.00</b>
<b>SOLO DV10</b> Carbon Fiber Tripod System (MIDS10SDV2) .....	<b>1315.60</b>
<b>SOLO DV 20</b> Carbon Fiber Tripod System (MIDS20SDV2) .....	<b>1562.28</b>
<b>SOLO DV 20</b> Alloy tripod with DS-20 fluid head, pan arm, camera plate, case (MIDS20SDVAT).....	<b>1249.00</b>
<b>1870</b> Solo DV 2-Stage Carbon Fiber Tripod with Compass (MH1870) .....	<b>1758.00</b>

**Prompter People**

Heavy Duty Tripod (PRTRHD).....	<b>399.00</b>
---------------------------------	---------------



**VT-4000** Fluid Head Tripod System

Weighing 8 lbs., the VT-4000 is a sturdy video tripod made from anodized aluminum that can support loads up to 8.8 lb. The two-way fluid head provides smooth operation, and features a 65mm half-ball mount with left and right pan bar mounts. The head's tilt angle is adjustable from +90° to -60°. and the head controls are positioned on the left side, which leaves your right hand free for the panning handle. 2-stage leg design allows you to adjust the height of the tripod from 27.6" to 59". The VT-4000 also has separate pan and tilt locks, bubble level for precision leveling and mid-level spreader.



(MAVT4000) .....	<b>149.95</b>
VT-100 Tripod System with 2-Way Pan Head (MAVT100).....	<b>49.95</b>
VT-200 Tripod System with 2-Way Pan Head (MAVT200).....	<b>59.95</b>
VT-3000 Tripod System with Fluid Head (MAVT3000).....	<b>139.95</b>
VT-400 Aluminum Tripod System with 2-Way Fluid Pan (MAVT400).....	<b>129.95</b>

**Sachtle**

<b>Ace Fluid Head</b> with 2-stage aluminum tripod & on-ground spreader (SASACEMGS).....	<b>557.00</b>
<b>Ace Fluid Head</b> with 2-stage aluminum tripod & mid-level spreader (SASACEMMS) .....	<b>557.00</b>
<b>0373</b> FSB-4 Aluminum Tripod System (SAFSB4ML2S).....	<b>1049.60</b>
<b>0375</b> FSB-4 Carbon Fiber Tripod System (SAFSB4MLCFS).....	<b>1254.60</b>
<b>0372</b> FSB-4 Aluminum Tripod System (SAFSB4MLS).....	<b>893.80</b>
<b>0442</b> System FSB 6 T MD (SAFSB6TMD).....	<b>1476.00</b>
<b>0472</b> FSB-6 Aluminum Tripod System (SAFSB6ML1S).....	<b>1476.00</b>
<b>0475</b> FSB-6 Carbon-Fiber Tripod System (SAFSB6ML2CFS).....	<b>1804.00</b>
<b>FSB-6 / 2</b> MD Aluminum Tripod System (SAFSB6ML2S).....	<b>1623.60</b>
<b>0480</b> FSB-6 with Soom and Tri-Spreader (SAFSB6S).....	<b>2984.80</b>
<b>0450</b> FSB-6T Head with 75CF Tripod and Mid-Level Spreader (SAFSB6TML2CF).....	<b>1804.00</b>
<b>0443</b> FSB-6T Aluminum Tripod System (SAFSB6TML2S) .....	<b>1623.60</b>
<b>0742</b> FSB-8T Tripod System with DA 75L Tripod (SAFSB8TMLS) .....	<b>1902.40</b>
<b>0773</b> FSB-8 Tripod System with ENG 75/2 D Tripod (SAFSB8ML2S).....	<b>2115.60</b>
<b>0775</b> FSB-8 Tripod System with Speed Lock 75 Tripod (SAFSB8MLCFS).....	<b>2337.00</b>
<b>0772</b> FSB-8 Tripod System with DA 75L Tripod (SAFSB8MLS).....	<b>1935.20</b>
<b>0750</b> FSB-8T Tripod System with Speed Lock 75 Tripod (SAFSB8TMLCFS).....	<b>2337.00</b>
<b>DV-12SB</b> Carbon Fiber Hot-Pod Tripod System (SADV12SBHP).....	<b>5965.50</b>
<b>System 18 S1</b> ENG 2 MCF (SAS18S12MCF).....	<b>7708.00</b>
<b>System 18 S1</b> SL MCF (SAS18S1SLMCF) .....	<b>8183.60</b>
<b>4161</b> Soom Tripod System (SASTTSHPC).....	<b>2230.40</b>
Telescopic Tripod TT 75/2 CF with FSB 4 Fluid Head (SAFSB4TT).....	<b>1184.90</b>
Telescopic Tripod TT 75/2 CF with FSB 6 Fluid Head (SAFSB6TT).....	<b>1640.00</b>
Telescopic Tripod TT 75/2 CF with FSB 8 Fluid Head (SAFSB8TT).....	<b>2050.00</b>

**Slik**

<b>504QF-II</b> Tripod System with 3-way fluid-effect pan head (SL504QF2) .....	<b>129.95</b>
<b>505QF</b> Tripod with fluid pan head and quick release plate (SL505QF).....	<b>Call or Log-on</b>
<b>PRO 340 QF</b> Tripod with 504QF pan head (SLP340504QF).....	<b>124.95</b>
<b>Video Sprint II</b> Tripod with 2-way fluid-effect head, pan handle and nylon case (SL52).....	<b>89.95</b>
<b>DV Travel Pro</b> Tripod System with Fluid Head (SLDVTP).....	<b>199.95</b>

**Sony**

<b>VCT-VPR1</b> Remote Control Tripod (SOVCTVPR1).....	<b>129.99</b>
<b>VCT-VPR10</b> Remote Control Carbon Tripod (SOVCTVPR10).....	<b>599.99</b>
<b>VCT-VPR100</b> Highend Remote Tripod (SOVCTVPR100).....	<b>699.99</b>

**Sunpak**

<b>Video Pro M3</b> Tripod With Fluid Head (SUMP3TB) .....	<b>139.95</b>
<b>Video Pro M2</b> Tripod with Fluid Head (SUMP2M).....	<b>102.00</b>

**Velbon**

<b>CX-586/F</b> 3-Section Aluminum Tripod with 2-Way Fluid Head (VECX586F).....	<b>Call or Log-on</b>
<b>DV-7000</b> Tripod with 2-Way Fluid Head (VEDV7000).....	<b>189.95</b>

**Smith-Victor**

Dollypod V Wheeled Tripod with Pro-5 2-Way Head (SMDPV5).....	<b>246.00</b>
---	---------------

**VariZoom**

VZ-TK75A Aluminum Tripod System (VAVZTK75A).....	<b>189.00</b>
--	---------------

**Vinten**

<b>VB-AP2F</b> Vision Blue System with Floor Spreader (VVBAP2F).....	<b>1253.75</b>
<b>VB-AP2M</b> Vision Blue System with Mid Level Spreader (VVBAP2M).....	<b>1209.50</b>
<b>Vision blue5</b> Pozi-Loc Tripod With Head and Floor Spreader (VVB5APTF).....	<b>2337.00</b>
<b>Vision blue5</b> Pozi-Loc Tripod With Head and Mid-Level Spreader (VVB5APTM).....	<b>2427.20</b>

## Head Handles &amp; Accessories

<b>Libec</b> PH-7 Extendable pan handle (LIPH7).....	<b>Disc</b>
<b>Magnus</b> PB-2 pan bar for VT-4000 tripod (MAPB2).....	<b>18.95</b>
<b>Sachtler</b> DV75 pan bar (SAPADV2).....	<b>77.90</b>
<b>Sachtler</b> 3471 telescopic pan handle (left) (SATLPBDV).....	<b>340.30</b>
<b>Sachtler</b> 3470 telescopic pan handle (right) (SATRPBDV).....	<b>340.30</b>
<b>Sachtler</b> 3271 telescopic pan handle (left) (SALPAV18).....	<b>340.30</b>
<b>Sachtler</b> 3270 telescopic pan handle (right) (SARPAV18).....	<b>340.30</b>
<b>Sunpak</b> Video PRO M3 pan handle (SUPHM3).....	<b>14.95</b>
<b>Vinten</b> Telescopic pan bar with clamp (black) (V321991).....	<b>282.90</b>
<b>Vinten</b> Fixed length pan bar (V3219110).....	<b>159.80</b>

## Manfrotto

701HLV pan handle (MA701HLV).....	<b>22.00</b>
503LV pan handle (MA503LV).....	<b>33.47</b>
501HLV pan handle (MA501HLV).....	<b>22.49</b>
519LV pan handle for 519 pro fluid head (MA519LV).....	<b>28.25</b>
501LVN pan handle (MA501LVN).....	<b>23.89</b>
R701,224B replacement handle for 3130 head (MAR701).....	<b>12.95</b>
509HLV Pan Bar for Video Heads (MA509HLV).....	<b>39.95</b>
524ADAPT 8-12 pin lens control adapter (MA524ADAPT).....	<b>149.95</b>
Clamp accessory for pan bar RCS (MAMVR901APCL).....	<b>49.99</b>
AV-R to Manfrotto remote adapter 7.8" cable (MA522AV).....	<b>23.24</b>
R701,224B replacement handle for 3130 head (MAR701).....	<b>12.95</b>

## Dot Line

DLC Cinema Skater Dolly (DODLSKATER).....	<b>179.95</b>
DLC 23" Camera Slider (DODLSLD23).....	<b>119.95</b>
DLC 47" Camera Slider (DODLSLD47).....	<b>149.95</b>

## Track, Cine Dollies &amp; Accessories

<b>alm</b> Mini Cart Table-Top Dolly (ALMCO).....	<b>66.95</b>
<b>alm</b> Action Cart Table-Top Dolly (ALACZ).....	<b>143.95</b>
<b>Black Bear</b> D200 Dolly System (BLD200).....	<b>4498.95</b>
<b>Black Bear</b> Dolly Platform Configuration (BLD100).....	<b>1406.50</b>
<b>Black Bear</b> 4' Foldable Straight Dolly Track (BLST01).....	<b>348.95</b>
<b>Black Bear</b> 8' Foldable Straight Dolly Track (BLST02).....	<b>623.95</b>
<b>Cinetics</b> miniSkates Tripod Dolly Wheels (CIMS).....	<b>74.95</b>
<b>Cinetics</b> CineSkates Camera Sliders (CICS).....	<b>150.00</b>
<b>CobraCrane</b> 5237 Tracking Dolly without Track (CODQ).....	<b>304.28</b>
<b>CobraCrane</b> 210062 Dolly Track (COTTD).....	<b>134.95</b>
<b>CobraCrane</b> 210049 Tracking and Dolly Kit (COTD).....	<b>449.00</b>
<b>Digital Juice</b> LowRider mini camera support (DILRM).....	<b>139.95</b>
<b>Digital Juice</b> LowRider Mounting Kit (DILRMK).....	<b>39.95</b>
<b>Digital Juice</b> Orbit dolly (DIOD).....	<b>839.50</b>
<b>Digital Juice</b> Orbit dolly 8" pneumatic wheel set (DIPW).....	<b>279.95</b>
<b>Digital Juice</b> Orbit dolly T-bar handle kit (DITBH).....	<b>139.95</b>
<b>Digital Juice</b> FlexTrac & Wheel for Orbit Dolly (DIODFWS).....	<b>499.95</b>
<b>Digital Juice</b> Orbit Micro Portable Camera Dolly (DIOMCD).....	<b>65.95</b>
<b>Digital Juice</b> SliderDolly Tracking System (40") (DISD40).....	<b>394.95</b>
<b>Digital Juice</b> SliderDolly Tracking System (64") (DISD64).....	<b>769.95</b>
<b>Digital Juice</b> SliderDolly Leveling Leg (DIALSLD).....	<b>134.95</b>
<b>Digital Juice</b> High Hat Kit for Slider Dolly (DIHAKSD).....	<b>129.95</b>
<b>Digital Juice</b> 75mm Ball Head Adapter (DI75MMBHARS).....	<b>19.95</b>

## Spreaders &amp; Dollies

<b>Acebil</b> D1 Dolly for Prosumer Tripods (ACD1).....	<b>120.00</b>
<b>Acebil</b> D3 Dolly for Professional Tripods (ACD3).....	<b>200.00</b>
<b>Davis &amp; Sanford</b> W3 Dolly (DAD3).....	<b>41.20</b>
<b>Davis &amp; Sanford</b> W4DX Deluxe Dolly (DADFD).....	<b>139.98</b>
<b>Libec</b> DL-2 dolly for the TH-M20 tripod (LIDL2).....	<b>90.00</b>
<b>Libec</b> SP-2B Ground Spreader (LISP2B).....	<b>86.40</b>
<b>Manfrotto</b> On-ground tripod spreader (MA165).....	<b>60.49</b>
<b>Manfrotto</b> On-ground tripod spreader (MA165MV).....	<b>68.95</b>
<b>Manfrotto</b> 114 heavy-duty cine/video dolly (MA114).....	<b>299.90</b>
<b>Manfrotto</b> 114MV cine/video deluxe dolly (MA114MV).....	<b>274.00</b>
<b>Manfrotto</b> 127 portable video dolly (MA127).....	<b>154.89</b>
<b>Manfrotto</b> 127VS variable spread basic dolly (MA127VS).....	<b>164.90</b>
<b>Manfrotto</b> 181 automatic folding dolly (MA181).....	<b>244.89</b>
<b>Manfrotto</b> 181B automatic folding dolly (black) (MA181B).....	<b>269.00</b>
<b>Manfrotto</b> Mid-level Spreader (MA537SPRB).....	<b>94.90</b>
<b>Pearstone</b> DWL-2 Universal Tripod Dolly (PEDWL2).....	<b>41.95</b>



## Atlas 10 LTS 35" DSLR Slider Kit



Designed with a ball bearing system that very smoothly slides a DSLR rig up to 10 lbs. in any possible direction – sideways, forward, backward, up, down, panoramically, and at angles. It can also be used as a crane when attached to a tripod, and can optionally be transformed into a counter-balanced vertical pulley system. Included all-terrain legs can adjust to stand firm on all surfaces and to then level off and compensate for any unevenness.

Atlas 10 35" LTS DSLR Slider w/ All-Terrain (CIA10TL35).....	<b>829.00</b>
Atlas 10 DSLR Camera Slider with 66cm Rails (CIA10L26).....	<b>579.00</b>
Atlas 10 - 35" LTS with Regular Ball Feet (CIA10L35).....	<b>679.00</b>
All Terrain Legs (CIUATL).....	<b>225.75</b>
All Terrain Foot (CIATBF).....	<b>7.50</b>
Atlas 30 with legs and 100mm Ball (CIA30TLB47).....	<b>1489.25</b>
26" Atlas FLT DSLR Slider w/ All-Terrain Legs (CIA10TL26).....	<b>729.00</b>
60" Atlas 10 Camera Slider w/ All-Terrain Legs (CIA105TL).....	<b>929.98</b>
35" Atlas 10 FLT Slider with Standard Legs (CIA35SL).....	<b>629.98</b>
35" Atlas 10 FLT Slider with All-Terrain Legs (CIA35TL).....	<b>779.98</b>
Trawly Compact Camera Dolly (CITCCD).....	<b>449.00</b>
Camera Slider Case (42") (CICSC).....	<b>189.95</b>
Camera Slider/Grip Case (CICSGC).....	<b>346.95</b>
Atlas FLT Camera Slider Case (CIAFLTSC).....	<b>149.95</b>
Camera Slider Case with Wheels 60" (CICSCW60).....	<b>346.95</b>

<b>Digital Juice</b> C-Stand Adapter Kit (2 Pack) (DICSA2).....	<b>112.50</b>
<b>Digital Juice</b> SliderDolly Mounting Adapter (DIMASD).....	<b>19.95</b>
<b>Ikan</b> FDD-TW track wheel set (IKFDDTW).....	<b>180.00</b>
<b>Indie-Dolly</b> Universal Dolly for Dolly Tracks (INCTD).....	<b>1194.95</b>
<b>Indie-Dolly</b> Curved Track Kit (INCTK).....	<b>648.95</b>
<b>Indie-Dolly</b> IND.SPR.D Singleman Dolly (INSPRD).....	<b>474.95</b>
<b>Indie-Dolly</b> IND-S.KIT Straight Track Kit (INSTK).....	<b>548.95</b>
<b>Mathews</b> Doorway dolly (MADDW).....	<b>1769.99</b>
<b>Mathews</b> Doorway Dolly with turret (MADDWT).....	<b>5179.95</b>
<b>Mathews</b> Round-D-Round doorway dolly (MARDRDDW).....	<b>2439.99</b>
<b>Mathews</b> Multifunctional DC-Slider (MADCSLIDER).....	<b>5820.00</b>
<b>Mathews</b> 24-39" Adjustable Bazooka (MABAZ).....	<b>1034.00</b>
<b>Mathews</b> Centipede - Set of 2 (MACS2).....	<b>2114.00</b>
<b>Mathews</b> 8' Heavy Wall Track - Straight (MATS8).....	<b>466.00</b>
<b>Mathews</b> Seat for Round-D-Round (MASRDRDDW).....	<b>258.95</b>
<b>Mathews</b> Secondary Offset Arm for Round-D (MASSOSA).....	<b>49.99</b>
<b>Mathews</b> Heavy Wall Track - Straight - 4 Foot (MATS4).....	<b>360.00</b>
<b>Opteka</b> GLD-200 23" Camera Track Slider (OPTGLD200).....	<b>99.95</b>
<b>Opteka</b> GLD-400 47" Camera Track Slider (OPTGLD400).....	<b>139.95</b>
<b>Opteka</b> GLD-300 33" Camera Slider (OPTGLD300).....	<b>119.95</b>
<b>Pico Dolly</b> Camera Table Dolly (PIPCPD1).....	<b>59.99</b>
<b>Varavon</b> S900 SLIDE CAM 47mm (VAS900SC).....	<b>384.99</b>

## Head Quick Release Plates

<b>Bescor</b> QS770 quick release plate for TH-770 (BEQS770).....	<b>19.20</b>
<b>Cartoni</b> B511 quick release plate (CAB511).....	<b>129.95</b>
<b>Cartoni</b> A500 quick release plate (CAA500).....	<b>74.95</b>
<b>Gitzo</b> G065 Monitor platform (GIG065).....	<b>82.16</b>
<b>Libec</b> All-in-One Camera Platform and Sliding Plate (LIAP5).....	<b>64.80</b>
<b>Libec</b> QR Shoe Plate for TH-650DV (LITH650DV6).....	<b>20.00</b>
<b>Libec</b> Quick Release Plate for RH45 Fluid Head (LIRH452).....	<b>59.95</b>
<b>Magnus</b> QR Plate for VT-100/200/300 (MAVTQR10).....	<b>8.95</b>
<b>Magnus</b> QR Plate for VT-3000 (MAVTQR300).....	<b>12.95</b>
<b>Magnus</b> QR Plate for VT-4000 (MAVTQR400).....	<b>14.95</b>
<b>Manfrotto</b> Long QR mounting plate (MA504PLONG).....	<b>64.90</b>
<b>Manfrotto</b> QR video camera plate (MA501PLONG).....	<b>69.95</b>
<b>Manfrotto</b> Side plate for 501 head (MA501.03).....	<b>29.57</b>
<b>Manfrotto</b> Long pro video QR plate (MA357PLONG).....	<b>79.90</b>
<b>Manfrotto</b> QR with video pin (MA030VHS14).....	<b>21.00</b>
<b>Manfrotto</b> QR plate for video (MA357PLV).....	<b>30.50</b>
<b>Manfrotto</b> 509PLONG QR Plate for 509HD (MA509PLONG).....	<b>69.95</b>
<b>Miller</b> 860 quick release plate (M860).....	<b>139.52</b>
<b>Miller</b> 1/4"-20 and location pin adaptor carriage (MI493).....	<b>29.90</b>
<b>Miller</b> 489 Camera mounting plate (MI489).....	<b>122.59</b>
<b>Miller</b> 490 Camera mounting plate (MI490).....	<b>80.73</b>
<b>Miller</b> 1204 Camera Plate for Compass 15 (MI1204).....	<b>149.95</b>
<b>Pearstone</b> QR plate for VT-2000/2100 (PEQRVT2000).....	<b>10.99</b>
<b>Sachtler</b> Touch and Go DV 8 wedge plate (SA1464).....	<b>79.95</b>
<b>Sachtler</b> Sideload Plate S (SAWPDV1).....	<b>62.32</b>
<b>Sachtler</b> Touch and Go 16 plate dolly (SA1064).....	<b>101.68</b>
<b>Sachtler</b> Touch and Go DV wedge plate (SAWPDV2).....	<b>69.70</b>
<b>Sachtler</b> 165 DSLR plate for cine DSLR head (SADSLRPC).....	<b>86.10</b>
<b>Sachtler</b> Touch and Go adapter w/wedge plate (SA1091).....	<b>319.80</b>
<b>Sachtler</b> Plate for Ace Fluid Tripod Head (SAPDSLACE).....	<b>57.40</b>
<b>Sachtler</b> Touch & Go Quick Release Plate (SATGAPS).....	<b>71.34</b>
<b>Sachtler</b> 1096 Quick Release Plate (SAQRPM).....	<b>231.24</b>
<b>Slik</b> QR plate for 505QF, 506QF & 322VF (SLQRS505QF).....	<b>Log-on</b>
<b>Slik</b> QR platform for 500QF series (SLQR503QF).....	<b>Log-on</b>
<b>Smith-Victor</b> QR plate for Propod III, Pro 300 (SMQRPPP3).....	<b>11.95</b>
<b>Smith-Victor</b> QR plate for Pinnacle tripods (SMQRPP).....	<b>6.50</b>
<b>Vinten</b> Camera Plate for Vision 3AS /5AS (VIV0431901).....	<b>127.92</b>
<b>Vinten</b> Camera Plate for Pro-10 (V3809900SP).....	<b>72.16</b>
<b>Vinten</b> Camera Mounting Plate for Pro-6 Head (V3864900SP).....	<b>79.95</b>
<b>Vinten</b> Camera Mounting Plate (V3364900SP).....	<b>127.92</b>

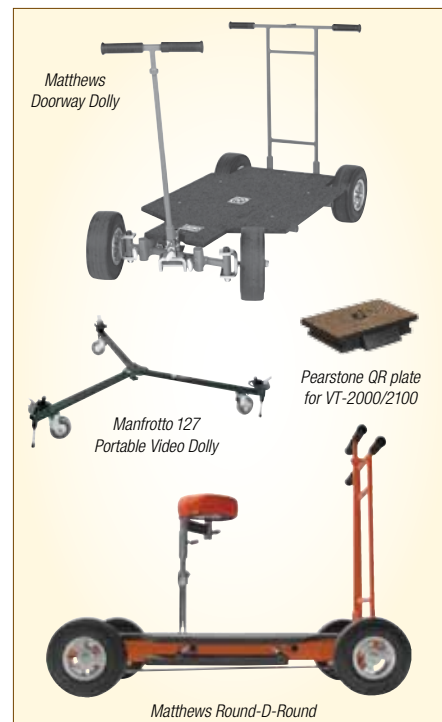

800-947-1186 | 212-444-6686

Zoom & Focus Controllers

**Base Adapters**

**Alan Gordon**

Hi & Lo-Hat mounting board (ALHHB).....**39.95**

**Birns & Sawyer**

Hi-Hat Mounting Board (BIHHB).....**59.95**

**Cinevate Inc**

100mm Ball Assembly (CIBA100).....**103.25**

**Gitzo**

75mm Half Bowl Video Head Adapter (GIGS5321V75).....**104.50**

**Manfrotto**

75mm Half-ball with short locking handle (MA520BSH).....**49.95**

High hat adapter (MA500BSH).....**48.25**

Video head bowl adapter Kit (MA325N).....**67.76**

75mm half ball (MA520BALL).....**43.90**

Short hi hat locking handle (MA319SH).....**28.99**

75mm to 100mm bowl adapter (MA319).....**32.99**

100mm ball leveler (MA500BALL).....**42.95**

**Sachtler**

75mm to 100mm bowl adapter (SA3906).....**172.20**

**GLIDECAM**

**Camcrane 200**



Tripod mounted, boom-arm, camera crane designed to smoothly boom a camera with precision and fluidity—up, down and 360°. Variable vertical boom from floor to 10' or 8'. 4 boom length combinations and a capacity of 25 lbs at 8' and 30 lbs at 6.5'. Folds to 3.3'. (GLCC200)..... **Call or Log-on Vista Head HD (GLVHHD).....899.95**



**CobraCrane I • CobraCrane II**

Single and Dual Bar Jib Arm



They offer an 8' reach when matched with a 5' tripod and can sweep the ground for low angle applications. From the ground level the camera can be tilted up over 90°, allowing users to obtain a great perspective shot. Sweeping vistas of landscapes, panoramas and sporting events are possible. The over-the-top shot is also ideal for cooking and food marketing videos, and other high perspective shots. Solidly constructed and built to last, they assemble fast and easy without tools.

CobraCrane I (COCC1).....**249.95**

3' Extension for CobraCrane I (COEK1).....**134.95**

CobraCrane I with Extension Kit (COCC1EK1).....**358.95**

CobraCrane II (COCC2).....**408.50**

CobraCrane I Plus (COCC1P).....**429.95**

CobraCrane II Plus (COCC2P).....**539.00**

Pan Kit V2 One for CobraCrane I and II (CACCPKVO).....**219.95**

IHD Portable Crane (COCCIHD).....**479.95**

II HD Portable Crane (COCCIIHD).....**699.95**

FotoCrane UltraLite Single Bar Jib (COFCL).....**271.95**

FotoCrane Xtreme Extendable Single Bar Jib (COFCE).....**408.50**

Tripod w/Fluid Head-works with any CobraCrane (COCC1T).....**319.95**

CobraCrane Backpacker (COCCBP).....**319.00**

Padded Bag for CobraCrane (COCCBC).....**87.50**

Mini Monitor Mount (COMMM).....**38.95**

Carry Bag for FotoCrane/Backpacker (COCCBP).....**48.50**

12' LANC Extension Cable (COEC12).....**18.50**

25' Camera LANC Cable (COLEC25).....**24.50**

Universal Clamp (COUC).....**28.50**

**Libec**

**ZC-3DV Zoom Controller**

- Control DV/HDV cameras via LANC
- Zoom speed varies from slowest to fastest with the touch of a thumb
- Outlet cable and can be clamped on tripod pan handles, monopods, stabilizers, and other such devices.



#LIZC3DV.....**114.99**

**ZFC-5HD:** Remote Zoom and Focus Control for LANC and Panasonic Cameras (LIZFC5HD).....**164.95**

**ZC-9EX Zoom Controller**

- Designed for XDCAM-EX camcorders as well as Fujinon and Canon ENG lenses. Turns handheld camcorders into studio cameras.
- #LIZC9EX.....**154.95**
- #LIZC9P (for ENG Canon & Fujinon lenses).....**149.90**
- Sony PMW EX Adapter (LI9EX).....**39.60**
- LANC/AV Adapter Cable for Sony Cameras (LIA3AV).....**16.60**



**Manfrotto**

**521 Lens Controller**

Built onto a small clamp, the controller can be mounted to a wide range of supports — pipes, bars, tubes, and flat surfaces.



#MA521PFI.....**236.95**

#MAMVR901ECPL (for cameras w/AV-R connection for LANC).....**139.95**

Remote Control Clamp EX (MAMVR901ECEX).....**229.89**

RC Clamp LANC Remote Control (MAMVR901ECLA).....**204.90**

**524CFI ENG Lens Remote Controllers**

With record start/stop and a speed dial, these controllers allow users to either pre-select a zoom speed or change speed midstream.



#MA524CFI (pan bar mounted for Canon, Fujinon lenses).....**264.52**

Handle Remote & Adapter Kit (MAMVR901EPLA).....**249.95**

RC Pan Bar EX Remote for PMW EX (MAMVR901EPEX).....**295.90**

522SCA Remote Control Cable - 9.8" (MA522SCA).....**9.90**

<b>bebob</b> Zoe-DVXL Universal Zoom Controller (BEZOEDVXL).....	<b>234.95</b>
<b>D/Focus Systems</b> D/Zoom Gear Lever (DFDZ).....	<b>175.00</b>
<b>Fujinon</b> MS-01 Rear Zoom and Focus Lens Control Kit (FUMS01).....	<b>1749.95</b>
<b>Fujinon</b> MS-01/X1 Semi-Servo Lens Control Kit (FUMS01X1).....	<b>1899.95</b>
<b>Fujinon</b> MS-11 Semi Servo Zoom/Focus Control Kit (FUMS11).....	<b>2849.95</b>

**VariZoom**

**VZ PRO-L • PG-L • Pro-EX**

Remote Variable-Speed Zoom & Focus

They offer precise, variable speed zoom, manual focus control, and wakeup from standby for cameras with LANC jack. Built with a sturdy-grip handle.



VZ-Pro-L (LANC) (VAVZPROL).....**245.00**

VZ-PG-L Compact (LANC) (VAVZPGL).....**266.86**

VZ-Pro-EX for Sony PMW-EX1 (VAVZPROEX).....**298.95**

**Pro Lens Controllers**

Pro Zoom Control for Fujinon 8-pin lens (VAVZPROF).....**340.00**

Rear focus control for 8-pin Canon lens (VAVZPROFCC).....**499.50**

Rear focus control for 8-pin Fujinon lens (VAVZPFCF).....**474.95**

VZ PG-EX zoom control for PMW-EX Series (VAVZPGEX).....**329.95**

VZ Pro-PZFI Control for Panasonic (VAVZPROPZFI).....**339.95**

VZ-PGF Deluxe Zoom Controller (VAVZPGF).....**427.45**

VZ-PG-PZ Remote Zoom Controller (VAVZPGPZ).....**349.50**

VZ-PRO-C Pro Zoom Controller (VAVZPROC).....**340.00**

**VariZoom Extension Cables and Accessories**

10' Cable for Canon & Fujinon 8-Pin Lenses (VAVZEXT810).....**99.95**

20' Cable for Canon & Fujinon 8-Pin Lenses (VAVZEXT820).....**101.94**

10' Ext. Cable for EX-1 (VAVZEXTEX10).....**75.95**

20' Extension Cable for EX-1 (VAVZEXTEX20).....**98.95**

10' Ext. Cable f/Panasonic VA-Stealth-PZFI (VAEXTPZF10).....**39.95**

20' Ext. Cable f/Panasonic VA-Stealth-PZFI (VAEXTPZF20).....**54.95**

50' Ext. Cable f/Panasonic VA-Stealth-PZFI (VAEXTPZF50).....**85.45**

Mini AV to LANC Converter Cable (VAVZAVLANC).....**18.95**

Pouch for VZ-PRO and VZ-PG Series (VAVZP610).....**10.99**

Canon 8-pin to 12-pin Fuji Cable Converter (VAVZC8F12).....**94.95**

**VZ-PFI • Rock-PZFI**

ENG Zoom Remote Controls

Compact zoom/focus and iris control for the AG-DVX100B and AG-HVX200. The zoom rocker is pressure-sensitive, while the independent knobs for focus and iris may be controlled manually or set to pick up the exiting camera setting automatically.



#VAVZPFI (Focus and Iris only).....**142.45**

#VAVZROCKPZFI (Zoom, Focus and Iris).....**230.54**

Rock-DVX & VZ-PFI Studio Setup (VAVZROCKZF).....**230.54**

**Stealth / Stealth LX**

Camcorder Lens Controllers

Experience precision variable-speed control over camera zooms. Ramp up from slow to fast and then slow again with custom-designed "throttle style" zoom. Stealth LX steps up with frame forward and reverse control and autofocus on/off.



#VAVZSTEALTH (Stealth for LANC).....**118.95**

#VAVZSDVX100 (Stealth for Panasonic DVX-100 series).....**99.00**

#VAVZSTEALTHL (Stealth LX for LANC).....**148.95**

#VAVZSHVX200 (Stealth for AG-HMC40/AG-HMC150).....**187.95**

**VZRock Series**

Camcorder Lens Controllers

Controls zoom, focus and record. Wide-sweep variable rocker. Data button for on-screen information. Review taped footage with F+ and F-.



#VAVZROCK (for LANC camcorders).....**203.95**

#VAVZROCKDVX (for Panasonic camcorders).....**165.13**

#VAVZROCKF (for Fujinon 8-pin lenses).....**221.96**

#VAVZROCKEX (for PMW-EX1/3).....**177.61**

Pouch for VZ-Stealth & VZ-Rock (VAVZP54).....**8.49**

**Autocue Starter Series**

Low-cost prompting packages, they provide everything you need, pre-assembled for easy installation. The on-camera units can be transformed into straight-read, floor-standing. Non-reversing monitors (7"-17") or use your iPhone/iPad.



- #AUOCUSSP10LI (10" Starter Series LITE Package) ..... **1098.95**
- #AUOCUSSP10 (Starter Series 10") ..... **1598.95**
- #AUOCUSSP17 (Starter Series 17") ..... **1898.95**
- #AUOCUSSP17LI (SSP17 LITE)..... **1498.95**
- #AUOCUSSP17D (17" Direct-View Starter Series Package)..... **998.95**

**Autocue**

**OCU-SSPIPADLITE iPad Prompter**

Convert an iPad (not included) into a portable teleprompter. Package includes a wide-angle teleprompter hood, Gold Plate mounting system, and a Mounting plate for iPad Broadcast quality prompter glass (70:30). Can be fitted in landscape or portrait mode.



- #AUIP ..... **798.95**
- OCU-SSPIPAD iPad Prompter (AUSIP)..... **1298.95**

**datavideo TP-300-IP**

Teleprompter Kit For iPad

Special 60/40 Glass allows the presenter to read the script and the camera to see the subject. Scripts or cue sheets can be copied and pasted into the DV prompter app software and scrolled at a set automatic rate or controlled via included wired/wireless remote. iPad can be attached front-of-cam or below-lens or used standalone.



- #DATP300I..... **575.00**
- Teleprompter Kit for Android Tablet (DATP300)..... **575.00**

**ikan Elite**

iPad Teleprompter Kit

Uses ikan's Elements camera support with a sturdy prompter hood to function as a through-the-glass teleprompter or a rod-based camera support by using only the included base plate. Compatible with DSLR and small to mid-size video cameras



- #IKPTE..... **599.95**
- Bluetooth Remote for "Elite" Prompter (IKER)..... **71.00**

**ikan PT1000W**

8" Widescreen Portable Teleprompter

Use this kit to achieve a portable teleprompting setup, even with a smaller shoulder-mount camera. Included software lets you create and edit scripts, even on the fly. LCD can be used as a standard widescreen video monitor when not in use as a teleprompter.



- #IKPT1000W ..... **619.95**

**ikan PT2500**

8" Portable Teleprompter

Ideal for DSLR models and mid-sized camcorders such as the Canon XF305. Easy to setup, uses high-quality 70/30 prompter glass. Has a VGA input as well as two composite ports. Includes a full-featured scrolling text editor.



- #IKPT2500 (8" Portable Teleprompter) ..... **799.95**
- #IKPT3100 (15" Location/Studio Teleprompter)..... **1299.00**

**LISTEC PromptWare PW-04**

4" Teleprompter Kit

Attaches to a small video camera via one of the 5 included lens adapter rings. The PW-04 employs Droid or iPhone as a prompting source for corporate meetings, instructional videos, seminars or advertisements. The PW-04 can be clamped to a table or mounted on a tripod and operated remotely.



- #LIPW04 ..... **319.00**

**MIRROR IMAGE Teleprompters, Inc**

**PB-15**

15" Price Buster Prompter

Features image reversal, 1024 x 768 resolution and brightness of 250 nits. Has a removable luggage-grade Cordura hood/lens surround. Includes a 15" color LCD monitor and an easy-to-use dual screen software that allows you to control the prompter from a PC.



- #MIPB15 ..... **985.00**



**Hdi Pro2**

iPad Teleprompter

Attaches to pro and consumer cameras and uses a specially designed bracket to securely hold your iPad whether you use a steadicam, jib or handheld. Includes anti-reflection mask, camera bar mount, handheld grip, hood lens sock and custom waterproof military-grade SKB case.



- #PRPPHDIPRO2..... **1182.95**



**iPad Bracket**

The ProPrompter iPad Bracket lets you use the iPad as a professional teleprompter for off-camera or live-stage prompting. The bracket attaches to a standard 1/4"-20 tripod mount and holds the iPad securely in place. This affordable, mobile solution bring polish and sophistication to field reporting, corporate videos, video podcasts, speeches, and any other scripted productions.



- #PRPPIB ..... **127.50**

**Prompter/People**

**ProLine iPad Teleprompter**

Readable over 12', it sets up fast (no tools) and supports various camera sizes. It features a premium HD 60/40 glass beamsplitter, high quality glass that is resistant to scratches and rear antireflection coating. Folds flat for storage or storage. Includes wireless remote.



- #PRPROIPAD2..... **1399.00**

**Prompter/People**

**UltraLight iPad Teleprompter**

Easily readable to over 12' and offers an iPad cradle or a cradle plus an iPad. It provides an adaptor for use with iPhone / iPod Touch. Upgradeable to 8" LCD.



- UltraLight iPad 2 Teleprompter (PRULIPAD)..... **599.00**
- UltraLight iPad 2 Teleprompter (PRULIPAD2)..... **599.00**
- Ultralite iPad ENG Teleprompter (PRULIPADENG) ..... **799.00**

**Prompter/People**

**PRO-D Series**

Uses a color LCD display with VGA and composite video inputs. The entire setup sits atop the included tripod riser. They include several software applications that enhance performance.



- PRO-D11** (11" LCD) (PRPL11) ..... **1599.00**
- PRO-D15** (15" LCD) (PRPL15)..... **1799.00**
- PRO-D17** (17" LCD) (PRPL17)..... **1999.00**

**Prompter/People FLEX-D Series**

The entire setup sits atop the included tripod riser. Includes Flip-Q Lite, software compatible with PC and Mac. The LCD panel features VGA and composite video inputs, and built-in speakers. Well suited for field or studio use.



- FLEX-D11** (11" LCD) (PRF11)..... **1099.00**
- FLEX-D15** (15" LCD) (PRF15)..... **1299.00**
- FLEX-D17** (17" LCD) (PRF17)..... **1499.00**
- FLEX-D19** (19" LCD) (PRF19)..... **1699.00**

**More Teleprompters & Accessories**

- Autocue/QTV** Wireless Hand Control (AUCONW) ..... **94.95**
- Autocue/QTV** ShuttleXpress Hand Control (AUCONSE) ..... **94.95**
- Listec** Simple VGA Splitter Cable (LICF3G00601) ..... **39.95**
- ProPrompter** Wired Remote - 25' cable (PRPPREMOTE)..... **55.95**

**Prompter People**

- UltraLight 8" Teleprompter (PRUL8)..... **899.00**
- UltraLight iPad 2 Teleprompter (PRULIPADENG2) ..... **799.00**
- Flex iPad Teleprompter (PRFLEXIPAD)..... **899.00**
- Flex iPad Teleprompter (PRFLEXIPAD2)..... **899.00**
- REM-D-GRF Wired Controller (PRWC)..... **79.00**
- REM-D-KEY Wireless Remote (PRWR) ..... **79.00**
- Wireless Scroll Controller for iPad (PAREMICUE) ..... **59.00**

800-947-1186 | 212-444-6686

Professional Cases

**CAMRADE CB Single 1 camBag**

Padded, lightweight bag for pro camcorder up to 20.5" and accessories. It has an easy-access, dual-zippered camcorder compartment, two zippered pockets and a mesh pocket. (CACBS1).....



**159.00**

**CAMRADE wetSuits**

Give your camera ultimate "bad-weather" protection while maintaining easy access to all controls including the LCD. Noiseless cotton interior fabric reduces unwanted sound effects caused by wind and rain. Vinyl windows let you view controls.



- For Canon XF100/XF105 (CAWSXF100)..... **169.95**
- For Canon XF300/XF305 (CAWSXF300)..... **169.95**
- For AG-HVX200 (CAWSHVX200)..... **149.95**
- For HPX-250/AG-AC130/160 (CAWSHPX250)..... **185.07**
- For AG-AF100 (CAWSAGAF100)..... **135.88**
- For GY-HM100/150 (CAWSGYHM)..... **169.95**
- For PMW-EX1 (CAWSPMWEX1), NEX-FS100 (CAWSFS100)... **185.07**
- For PMW-EX3 (CAWSPMWEX3)..... **185.07**
- For Canon C300/C500 (CAWSC300)..... **209.95**



**CB-01A Production Bag**

Padded waterproof shoulder bag, has four removable interior pouches and four non-removable exterior zippered pouches. Zippered outside pouches. Made from an effective waterproof material. Dual center carry handles and a large shoulder strap made with an anti-slip fabric.



#CICB01A..... **199.95**



**CB33 Skinny Jimmy Camera Bag**

Heavy-duty bag made with a waterproof exterior, over-sized zippers and heavy-duty hardware. Interior is customizable via two

included removable dividers. In the front, there's a see through mesh pocket on the flap and a zippered compartment. Also two zippered side pockets. Carried by a padded shoulder strap or padded top grab handle. (CICB33)..... **104.95**

**CB23 DSLR / HD Backpack**

Rugged, customizable pack for all kinds of weather. Can hold a DSLR system as well as a 15" MacBook in its own 14 x 10 x 2" pouch. Made from tough, waterproof 450 ripstop nylon material. Inside dust cover to further protect your gear. Movable, customizable dividers allow you to configure the guts of the bag to suit your gear needs. Pack is accessed from the rear by an oversized zipper. Shoulder harness is wide, padded and comfortable. A top carry handle makes it easy to retrieve the pack from the trunk of your car or closet.



- #CICB23A..... **169.95**
- CB-03 AC Pouch (Gray with Orange Webbing) (CICB03)..... **26.95**

**f.64 VTX Camcorder Shoulder Bag**

Main compartment with 1/2" foam padding and adjustable interior divide. Detachable 2" wide shoulder strap, built-in leather carry handle and hide-a-way waist belt. Front pocket with a flat mesh expandable pocket and interior pockets for accessories. In Black (F6VTXB), Navy (F6VTXN) or Gray (F6VTXG)..... **56.50**



**DVC-777 / HDC-1010W**

**PEARSTONE Camcorder Cases**

Removable dividers allow for custom case configuration. Accommodates camcorder with a matte box or accessory lenses attached. Otherwise the same, the larger HDC-1010W has built-in wheels.



- DVC-777: 15 3/4 x 8 1/4 x 8 3/8" (LxWxH) (PEDVCB)..... **74.95**
- HDC-1010: 24 x 13 x 10" (LxWxH) (PEHDC1010W)..... **159.95**



**CCC-1A Full Size Camcorder Case**

Can carry full size camcorder with attached battery and lens. Thermoformed laminated foam layers allow a lightweight yet highly protective case. Double flap top opening ensures quick top handle grip access. Mini light can stay installed during transport as the flaps will zip up around it. Water tight zippers and a structural shape that expands to cocoon the equipment. Two large padded pockets (front & rear), flat pocket along the side, designated tripod plate pouch and a small set-up card pocket. Carried by a APSS shoulder strap, "Click" interlocking handles, car transport front grip, or seat belt securing slots. (KACCCTA).. **299.00**



**Pro Rain Covers**

Protects against dirt, dust and severe weather. Allows easy set-up with a clear vinyl panel on the control panel. Flexible sleeve covers the mic and another flexible sleeve with elastic cuff protects the viewfinder.



- #KARC1Q (for full-sized shoulder mount camcorders)..... **171.00**
- #KARC12Q (for camcorder / fully-equipped HD/SLR)..... **99.99**
- #KARC10Q (for medium-sized camcorders)..... **116.00**
- #KARC14Q (for camcorders / fully-equipped HD/SLR)..... **99.99**
- #KARC15Q (for HDV camcorders)..... **109.00**

**Pro-V Backpack**

Made of durable Ripstop fabric, will accommodate an HDV camcorder with or without a matbox; a large HD/SLR rig configuration; or a DSLR with up to a 300mm lens attached, plus 6-8 additional lenses. A fold-out tripod holder with a securing strap comfortably carries your video tripod. At the rear of the pack, a large padded pocket snugly fits up to a 15.4" laptop. Includes fully adjustable harness system, all-purpose work mat and elements cover. Pro-V 410 PL (13.6 x 11.8 x 20.5") (KABP410)..... **299.00**  
Pro-V 610 PL (13.6 x 12.2 x 25.2") (KABP610)..... **299.00**



**PL Compact Cases**

Lightweight bags hold your rig in safety while on location. Made from tough rip stop nylon, they are accented with KATA's Toblerone system that guards the bottom of the bag while also protecting it from ground moisture. Main compartment is opened via dual top zippers for rapid access. Interior is made with KATA's Aeriform Foam. Bags are carried by adjustable shoulder strap or one of three carry handles on the top and sides.



- CC-191 PL (9.5 x 9.5 x 17.3") (KAPLCC191)..... **91.08**
- CC-192 PL (10.2 x 11.0 x 20.9") (KAPLCC192)..... **125.00**
- CC-193 PL (10.2 x 12.2 x 22.4") (KAPLCC193)..... **132.48**
- CC-195 PL (12.2 x 13.4 x 25.2") (KAPLCC195)..... **159.00**
- CC-197 PL (14.2 x 13.4 x 27.6") (KAPLCC197)..... **231.71**



**Deca Doctor**

Made from 900 denier Cordura and ballistic nylon exterior with a 7-layer polypropylene foam protection system. Brushed polyester lining. Exterior side pockets. Removable internal rigid dividers. Carried by an ergonomic Grip-lock interlocking handle or a removable, adjustable shoulder strap with non slip pad. PC001 Deca Doctor Bag 1 (15.7 x 8.7 x 10.2") (PEPC001)..... **124.80**  
PC002 Deca Doctor Bag 2 (17.7 x 9.6 x 11.8") (PEPC002)..... **169.26**  
PC003 Deca Doctor Bag 3 (22.8 x 12.6 x 15.4") (PEPC003)..... **170.18**  
PC004 Deca Doctor Bag 4 (24.4 x 13 x 15.2") (PEPC004)..... **275.34**  
PC005 Deca Doctor Bag 5 (27.6 x 13.8 x 14.9") (PEPC005)..... **321.36**  
PC006 Deca Doctor Bag 6 (30.7 x 13.8 x 14.9") (PEPC006)..... **336.18**



**Cambio**

Carrier System w/Fluid Head Holds small camcorder with accessories, plus has built-in adjustable-height support system. Carried by a handle, a frame and axle trolley with integrated handle and camera platform. Heavy-duty wheels and axle can be chocked to prevent rotation. Support system consists of an expandable center steel column up to 56" that handles cameras up to 10 lbs. (PECA002)..... **Call or Log-on**



**Deca Transparent Raincover**

Protects your camera from extreme weather and adverse conditions. Made from TPU (Transparent Polyurethane) for maximum visibility and waterproof nylon. Exterior 6" ABS plastic track allows the addition of on-camera mini light and/or a wireless receiver and a special waterproof zipper on the cover's viewfinder protector. PR415 24.8" long (PEPRA415)..... **148.98**  
PR425 31.9" long (PEPRA425)..... **176.28**



**PM802 Deca 4.5-7.5" LCD Monitor Bag**

Carries 4.5-7.5" auxiliary camera LCD monitors. It is made from 900 denier Cordura and ballistic nylon with interior padding, a front panel that is protected by a transparent polyurethane shield and brushed polyester interior. (PEPM802)..... **124.02**  
PM803 Deca 9" LCD Monitor Bag (PEPM803)..... **146.64**  
PM804 Deca 17" LCD Monitor Bag (PEPM804)..... **254.28**



### Deca U-Bag

Made from 900 denier heavy-duty, water-resistant Cordura and ballistic nylon with a fully padded interior. Ultrawide U opening allows for insertion of camcorder without disturbing viewfinder and mic. Expandable end compartment accommodates camcorders of varying lengths. There are exterior accessory pockets and a removable internal LED lighting system that illuminates bag's interior and contents. Carried by a U-grip interlock carrying handle or a removable, adjustable shoulder strap with pad.



PC102: 25 x 12.6 x 14.6" (PEPC102).....**339.30**  
PC104: 30.3 x 15.4 x 16.2" (PEPC104).....**424.32**

### Deca PC301 Campack

Enough room to hold 17" camcorder with accessories. Has removable dividers, a back pocket that holds up to 15" laptop, side zippered pocket and 2 side pockets on the waist belt. It is carried by the Safeback integrated backpack system with heavy-duty padded straps and a waist belt.



#PEPC301.....**251.16**  
PC300 Deca Shell Camera Backpack (PEPC300).....**169.26**

### Deca PC302 Campack Rollpak

2-in-1 professional camera trolley/backpack with a host of industry leading advantages such as: exchangeable logo frame, interior strap to hold optional internal LED lighting system, padded rear pocket holds computer with up to 17" screen, carrying backpack system with built-in wheels and trolley. (PEPC302)...**294.06**



### Deca PC303 Campack Plus

Ergonomic backpack system for correct weight distribution and greater carrying comfort. Enough room to hold 20" camcorder without disturbing the viewfinder. Has removable dividers, a back pocket that holds up to 17" laptop, and folded cover which protects bag and contents from rain, dust and sun.



#PEPC303.....**322.14**

**PA1012** Deca Removable Shock-Resistant Pad (PEPA1012).... **8.58**

**PA1013** Deca Removable LED Lighting System (PEPA1013)... **24.96**

**PNES** Deca Neoprene Strap (PEPA1014)..... **18.72**

**CamWrap** for Sony PMW-320/350/500 (PEPW503)..... **195.00**

### Tenba Roadie II

HDSLR/Video Shoulder Bag

Provides you with a tool to get up and out the door with everything you need for your photo or video gig. Can hold two DSLRs, 6-8 lenses (up to a 400mm f/2.8 or 500mm f/4), and audio gear such as shotgun mics, recorder and phones. Or it can hold a larger video camera such as a RED (EPIC, Scarlet), Canon C300 or a Sony. Also has room for a 15" laptop in a rear padded sleeve. This sleeve makes airport screening quite convenient.



#TE638334.....**279.95**



### HIP-2 Hip Pack for Small Accessories

Holds tapes and batteries or other personal effects. Can be used in the belly position or fanny position. There is a pocket on the front, a zippered pocket on the top, three front slip pockets, a side pocket and a pocket for your keys. (POHIP2B).....**111.97**  
ACB-3B Assistant Camera Pouch with Belt (POACB3B).....**155.37**



### BKS-2XM Soft Backpack Camera Case

Flexible pack made from 1000-denier Cordura nylon fabric. Exterior contains several storage pockets as well as a tripod pocket and cinch. A padded laptop pocket can accommodate a notebook up to 17". The bag has the unique ability to expand its length and depth by 3" in each direction to facilitate storing a larger video rig. (POBKS2XM).....**233.49**  
RIG-3BKXSR Soft Camera Backpack (PORIG3BKXSR).....**190.09**



### BK-2N Backpack

For camcorders up to 12" with a 17" lap-top. Side tripod pocket with a cinch strap, camera cradle and additional accessory pockets. Extra foam padding and non-slip material on the shoulder, removable waist straps, and padded side support straps. Includes PB-B6 and PB-B9 pouches, small pillow, white balance card and illumination strip light pocket.



In Blue with Red Trim (POBK2N).....**329.95**  
In Black with Red Trim (POBK2NR).....**329.95**

### RIG-1SRK Rig Camera Case

Complete, zippered case for holding an assembled cine-style rig in shooting position. Rigid hollow-core plastic frame with a foam-padded, Veltex (touch fastened) interior and 1000D Cordura nylon exterior. The bottom of the case is reinforced and waterproofed. Includes a suede shoulder strap, lens cup, stuff sack and camera stuffer divider.



RIG-1SRK Rig Camera Case in Black (PORIG1SRK).....**214.95**  
RIG-2SR Rig Camera Case in Black (PORIG2SR).....**268.21**  
RIG-2SRK Rig Camera Case in Black (PORIG2SRK).....**355.12**  
RIG-3SRK Large RIG Camera Case in Black (PORIG3SRK)....**433.13**  
RIG-4SR Rig Camera Case in Black (PORIG4SR).....**355.01**  
RIG-4SRK Rig Camera Case in Black (PORIG4SRK).....**424.45**

### Lightweight Field Monitor Cases

Protect your flat-screen monitors and improve screen visibility. Custom-fit padded protection and a fold-out visor that shields the screen from sun glare. Soft suede shoulder strap included.



For Ikan VX-9 (POMOVX9), Marshall MO-70XP/651 (POMO70XP651), Sony LMD-940 (POMOLMD940), Panasonic BT-LH80W (POMOLH80W), BT-LH900 (POMOLH900), BT-LH910 in Blue (POMOLH910) or BT-LH910 in Black (POMOLH910B).....**181.41**  
For Panasonic LH-1700W or LH-1760 (POMOLH1700).....**259.53**  
For Marshall V-LCD50 (POMOLCD50).....**94.61**  
Rigid Frame Case for 17" Flat Monitors (POMO17G).....**233.49**



### BP-1 Waist Belt Production Pack

Main compartment has retractable divider. Has two front pockets and an adjustable waist belt with quick-release buckle, and "D" rings for additional accessories.



Blue (POBP1).....**81.60** Black (POBP1B).....**94.61**

**BP-2 Waist Belt** in Blue (POBP2).....**146.69**

**BP-2 Waist Belt** in Black (POBP2B).....**146.69**

### CTC-MINI Traveler Camera Case

1000 denier Cordura nylon case, it features rigid corrugated plastic reinforcement on back and sides, a padded 1" foam interior, and a no-sag bottom with foam padding and a non-slip bottom layer that easily wipes clean and provides extra water proof protection. Exterior and interior pockets provide room for batteries, and accessories. Carried by a suede leather-covered shoulder strap or carrying handles. Includes white balance card.



In Blue (POCTCMINI).....**156.00** In Black (POCTCMINIB).....**156.00**

### BP-3 Waist Belt Production Pack

Can carry small professional camcorders with accessories. Holds two pouches in place with a quick-release buckle. Large pouch has three exterior pockets and a retractable divider. The small pouch has two end pockets and a front pocket with slip pocket covered by a touch fastener flap. The pack includes a support strap for extra-heavy loads.



In Blue (POBP3).....**207.45** In Black (POBP3B).....**207.45**

### DVO Series Digital Video Organizer

A rigid frame provides an extra level of protection. Includes 8 interior components that allow you to create a custom protective environment for your camera and accessories. Soft suede shoulder strap included.



**DVO-1** in Black (PODVO1R)....**242.17** in Blue (PODVO1U)....**233.49**

**DVO-2** in Black (PODVO2R)....**259.53** in Blue (PODVO2U)....**225.04**

**DVO-3** in Black (PODVO3R)....**355.00** in Blue (PODVO3U)....**363.69**

### SS-2 Over-the-Shoulder Side Sling Pack

Form fitting, comfortable to wear and easy to fling on. For extra stability there is a waist cinch strap, which can be stored in a pocket. Padded, non-skid shoulder camera support pad. Five tool pockets and full zip around body pocket with a secret zippered pocket for wallet and passport. D rings for keys, cords and cables.



In Blue (POSS2).....**165.28** In Black (POSS2BL).....**172.73**



**CS-DV Series** Compact DV

**Camcorder Cases**

Protect and organize cameras and essential accessories. The bottom panel is reinforced with rigid plastic, thick foam, and a layer of anti-skid material. Padded pouches and camera cradle.



- CS-DV1U:** Black (POCSDV1R) ..... **69.30** Blue (POCSDV1U)..... **85.93**
- CS-DV2U:** Black (POCSDV2R)..... **103.29** Blue (POCSDV2U) .. **111.97**
- CS-DV3U:** Black (POCSDV3R)..... **146.69** Blue (POCSDV3U) .. **146.69**
- CS-DV4U:** Black (POCSDV4R)..... **190.09** Blue (POCSDV4U) .. **190.09**



**Quick-Draw** Pro Camera Cases

These lightweight, padded quick-draw cases feature a top-loading design and a protective aluminum viewfinder guard. They feature two trim exterior pockets and a dual-purpose, expanding rear pouch to accommodate a larger camera battery. Leather handle and heavy-duty, non-slip shoulder pad.



- CC-HD1:** Blue (POCCHD1) .. **349.95** Black (POCCHD1B)..... **407.00**
- CC-22:** Blue (POCC22PW)..... **398.00** Black (POCC22PWB) .. **398.41**



**Quick Slick** Rain Covers

Quick to put on, compact rain and dust protection cover, reinforced around the lens and viewfinder with non-skid neoprene to help keep it in place. Clear vinyl window for easy viewing of camera controls. Made for use with the eyepiece; limited functioning with a pop-out LCD screen.



- QS-2 (POQS2)**..... **149.49**
- QS-M3** for DSR-PD150/170 (POQSM3) ..... **94.61**
- QS-M4** for XH-G1, XH-H1, AG-HVX200, HDR-FX1, HDR-FX7, HVR-V1, HVR-Z1U, PMW-EX1 (POQSM4)..... **79.61**

**CTC Traveler Camera Cases**

Mid-size case with viewfinder protection. Reinforced layers of lightweight plastics and thick foam protect your camera and accessories. Anti-skid bottom adds an extra layer of protection against water and dirt. Includes suede strap.



- CTC-1:** Black (POCTC1B)..... **233.49** Blue (POCTC1) ..... **233.49**
- CTC-2:** Black (POCTC2B)..... **219.95** Blue (POCTC2) ..... **242.17**
- CTC-3:** Black (POCTC3B)..... **250.85** Blue (POCTC3)..... **250.85**
- CTC-4:** Black (POCTC4B)..... **328.97** Blue (POCTC4)..... **328.97**

**Camera Body Armor**

Snug-fitting jacket made of water-resistant, highly abrasive-resistant, soft-feel fabric that protects camcorders from bumps, hits and scratches. The interior side of the fabric has a mesh finish, to improve air flow around the camera. Included rain/dust cover fits into a convenient slip pocket.



- For Canon XF-300/XF305 (POCBAXF305)..... **276.89**
- For Panasonic AG-HVX200 (POCBAHVX200)..... **259.53**
- For Panasonic AG-AC130, AC160 (POCBAAC160)..... **294.25**
- For Panasonic AG-HPX370 (POCBAHPX3100)..... **415.00**
- For Panasonic AJ-HPX2000 (POCBAHPX2000)..... **399.00**
- For Sony PMW-EX1R (POCBAEX1R)..... **294.25**
- For Sony PMW-EX3 (POCBAEX3)..... **290.01**
- For Sony PMW-350 (POCBAPMW350)..... **415.00**
- For Sony PMW-350 EX (POCBAPMW350B)..... **415.77**
- For Sony PDW-700 (POCBAPDW700)..... **415.00**

**CC-235 Quick-Draw Camera Case**

Convenient way to carry and protect a pro camcorder on the ground, in your car and in the air. This padded 1000 denier Cordura nylon case has an internal plastic frame and a viewfinder guard for 100% protection and security. The case holds a camcorder with an on-board battery and most wireless configurations attached. The flared-wall design accommodates matte-boxes and large lenses so time is saved by not having to take these items off each time the camcorder is placed in the case. For extra long lenses there's a zippered Camera-Extension Pocket on the side that, when deployed, adds up to 3" to the interior length of the case. Includes an illumination strip light pocket.



- #POCC235..... **398.41**

**Cargo Cases**

Cargo cases with durable, 1000-denier Cordura exteriors, rigid frames, and dividable main compartments with 3 large outside pockets. Protect and organize your equipment.



- CAR-1** in Blue (POCAR1) ..... **181.41**
- CAR-2** in Blue (POCAR2) .. **190.09** in Black (POCAR2B)..... **190.09**
- CAR-3** in Blue (POCAR3) .. **207.45** in Black (POCAR3B)..... **207.45**

**Run Bags**

Carry and protect all types of gear. Main compartment is foam-padded with a rigid bottom panel. Removable divider-kit interior allows for custom protection.



- RB-1** in Blue (PORB1)..... **155.37** in Black (PORB1B) .... **155.37**
- RB-2** in Blue (PORB2)..... **172.73** in Black (PORB2B)..... **172.73**
- RB-3** in Blue (PORB3)..... **181.41** in Black (PORB3B)..... **181.41**
- RB-4** in Blue (PORB4)..... **216.13** in Black (PORB4B)..... **216.13**

**Carry-On Camcorder Case**

Compact, lightweight 1000 denier waterproofed Cordura nylon case with extra thick foam side walls, padded with a pillowing system. Built-in reinforced viewfinder protector and exterior pockets for accessories. Carried by suede leather-covered hand grips or a removable, adjustable shoulder strap with suede leather-covered pad.



- CO-0B** for pro camcorders up to 23" (POCO0B)..... **346.33**
- CO-PC** for pro camcorders up to 23" (POCOPC)..... **346.33**
- CO-AB-M:** Blue (POCOABM)..... **346.33** Black (POCOABMB)..... **319.95**

**PB-4100F**

**Hard Case with Foam Interior**

Hard resin plastic case with foam to cushion and protect a Blackmagic Cinema Camera, JVC GY-HMQ10U or Sony HXR-NX30U. The top features a reinforced carry handle and the front contains a handy pressure equalization valve. Dual, rugged latches keep the case shut. The case can accept Porta Brace's optional HB-10 or HB-40 shoulder strap.



- In Blue (POPB4100F) ..... **119.95**

**Rain Slickers**

Custom-fit rain-protection. 3-ply nylon. Fabuthane fabric with soft Tricot-backing protects against temperature changes and provides excellent rain protection. Works on a tripod or handheld. Flaps, vinyl windows and zippered openings provide easy operation.



- For PMW-EX1R (PORSX1RB), PMW-EX3 (PORSX3B), HXR-NX5 (PORSNX5UB), HVX-200 (PORSHVX200B), GY-HM700 (PORSHM700B), NEX-FS100U (PORSNEXFS100), AG-AC160 (PORSAC160), AG-AF100, PMW-F3 (PORSAF13B) or HVR-V1U (PORSV1B) ..... **159.95**
- RS-22** Rain Slicker (PORS22)..... **209.95**
- RS-33** Camcorder Rain Slicker (PORS33)..... **233.00**
- QRS-HMC80** Quick Rain Slicker (POQRSHMC80)..... **164.05**
- RS-AC160** for Panasonic AG-AC160 (PORSAC160)..... **198.77**
- RS-EXRFXB** Rain Slicker for XF-305 (PORSRFXB)..... **198.77**
- Storm Coat Extreme for Broadcast Cameras (POSTC2EX) ... **268.21**
- RS-FZ17B Rain Slicker for Sony Camcorders (PORSEFZ17B) .. **198.77**
- For PMW-EX3 With Nippos Battery (PORSX3SL7B) ..... **224.81**

**WPC-30R Wheeled Production Case**

Constructed of a strong ridged interior frame covered with 1000 denier Cordura fabric, with padded protection all around. Off-road inline skate wheels with strong steel axles for stability and traction. A comfortable, Vermont hard maple handle is mounted on strong steel telescoping beams which retract into the case for snag proof shipping. A divider kit allows customizing of an infinite number of storage compartments. Also includes an LI-GLW illumination strip light pocket.



- WPC-30R:** Blue (POWPC30R)..... **467.85** Black (POWPC30RB)..... **467.85**
- WRB-30R:** Blue (POWRB30R)..... **469.95** Black (POWRB30RB)..... **493.89**

**Soft Cases, Pouches & Accessories**

- CS-B9** Stuff Sack (Black, Single Pack) (POCSB9)..... **13.02**
- CS-B9** Stuff Sack (Black, Pack of 3) (POCSB93)..... **26.04**
- PB-10X15** Stuff Sack (POPB1015)..... **39.95**
- PB-B6** Stuff Sack (Black, Single Pack) (POPB6)..... **15.62**
- PB-B6** Stuff Sack (Black, Pack of 3) (POPB63)..... **30.38**
- PB-B812** Stuff Sack (Black, Single Pack) (POPB812)..... **16.49**
- PB-B812** Stuff Sack (Black, Pack of 3) (POPB8123)..... **34.72**
- PB-812IP** Padded iPad Carrying Pouch Black (POPB812IP)..... **16.49**
- PB-B9** Stuff Sack (Black, Single Pack) (POPB9)..... **17.36**
- PB-B9** Stuff Sack (Black, Pack of 3) (POPB93)..... **39.06**
- GPC-7X5** General Purpose Case (Black) (POGPC7X5)..... **42.53**
- TSA-Set:** TSA Safe Skies Locks and Pouch (POTSASET)..... **21.70**
- LI-2** LED Snakelight (Set of 2) (POLI2) ..... **13.02**
- LI-GLW** Case Interior Illumination Kit (POLIGLW) ..... **41.70**
- PHP-1** Polar Heat Pack (Pack of 10) (POPHP1)..... **10.42**
- DK-2** Divider Kit (PODK2) .. **53.80** **DK-3** Divider Kit (PODK3) .. **59.89**

**ATOMOS Ninja 2.0 • Samurai**

HD-SDI Hard Disk Recorder

- Real-time 10-bit recording
- Apple ProRes lossless codec
- 5" high-res touchscreen monitor
- Looping BNC SDI inputs
- 12-channel embedded audio • Two line-in audio channels
- FireWire 800 / USB 3.0 - on Master Dock



<b>Ninja 2.0</b> Video Hard Disk Recorder (ATN2).....	<b>995.00</b>
<b>Samurai</b> HD-SDI Hard Disk Recorder (ATAS).....	<b>1595.00</b>
<b>Ronin</b> Portable Recorder/ Monitor (ATRONIN).....	<b>2195.00</b>
<b>Ronin Duo</b> Portable Recorder / Monitor (ATRONINDUO).....	<b>3995.00</b>
Docking Station for Samurai (ATDSN).....	<b>129.95</b>
ATOMBAT001 Battery (ATB2600).....	<b>49.95</b>
ATOMCGR001 Battery Charger (ATCBP).....	<b>44.95</b>
AC Power Supply for Samurai and Ninja 2 (ATOMACP001).....	<b>79.95</b>

**VITEC FS-H200 Pro**

Portable DTE (Direct-to-Edit) Recorder

- Capture SD/HD video to Compact Flash cards. Supports DV and native HDV acquisition in a variety of resolutions and can record over 2.5 hours to a 32GB card.
- Clip thumbnail viewing, proxy content playback, MPEG4 proxy clips, FTP support and wired/wireless custom metadata logging, DV/HDV MXF support and 10-sec. retro cache.



#VIFSH200P0.....	<b>845.00</b>
3-Hour Battery for FS-H200 Pro (VIFSHCB).....	<b>199.00</b>
3-Hour Battery for FS-5 (VIBFS5).....	<b>119.95</b>
FS-5 Handle Mount Cradle (VICFS5).....	<b>119.95</b>

**Convergent Design**

**nanoFlash Bundle**

Records video, audio and timecode from an HD-SDI stream onto Compact-Flash cards. Incredibly small with low-power consumption, nanoFlash



is powered from a camcorder battery or included AC power supply. Records 1080i, 1080p 30/25/24 or 720p at full raster 4:2:2 MPEG-2, at 50/100 Mbps or 100/160 Mbps (I-frame only). Also offers HD-SDI I/O as well as LTC in, wired remote control and power/start/tally light connector.

#CONFB (nanoFlash Bundle).....	<b>1995.00</b>
#COLIB3 (Li-Ion Battery).....	<b>59.95</b>
#COCLIB (Battery Charger).....	<b>49.95</b>
#CODTAPPWRCLB (18" Tap Power Adapter Cable).....	<b>69.95</b>
Gemini 4:4:4 Uncompressed Video Recorder (CORG4442).....	<b>4995.00</b>
512GB 1.8" Solid State Drive for Gemini (COS12GBSSD).....	<b>1495.00</b>
Gemini C500 Option (COGC500OPT).....	<b>2495.00</b>

**SOUND DEVICES**

PIX 220i Video Recorder with IPS Display (SOPIX220I).....	<b>2295.00</b>
PIX 240i Video Recorder (SOPIX240I).....	<b>3295.00</b>
PIX 260i Rack-Mountable Video Recorder (SOPIX260I).....	<b>5625.00</b>
256GB SSD with Shim for PIX HD (SOPIXSSD4).....	<b>350.00</b>
Articulating Arm for PIX-220 and PIX-240 (SOPIXARM).....	<b>258.00</b>
2.5" SSD Drive Caddy for PIX (SOPIXCADDY2).....	<b>149.00</b>
Sun Shield for PIX-220/PIX-240 (SOPIXHOD).....	<b>46.80</b>
Polycarbonate LCD Cover (SOPIXLCD).....	<b>36.00</b>
Pix-Mount (SOPIXMOUNT).....	<b>30.00</b>
Rack-Mount Kit for PIX 260i (SOPIXRACK).....	<b>126.00</b>

**datavideo**

**DN-60** HDV CF Card Recorder

Portable and shockproof, the DN-60 provides hours of continuous standard- and HD recordings. Tripod and hot shoe mountable, it connects directly to HDV camcorders via Firewire cable. Features an 8 second pre-record buffer and built-in intervalometer for time lapse recording. Over two hours continuous recording on 4 AA batteries. (DADN60).....



**DN-200** HD / SD HDD Recorder

Built-in 250GB hard drive stores a minimum of 19 hours depending of the format. 8-sec. pre-record buffer; built-in intervalometer for time lapse recording, manually triggered single frame recording. #DADN200.....



**DN-400** Hard Drive Recorder

Records SD or HD from component, composite, S-Video or Firewire. Comes with a 250GB removable hard drive installed inside an enclosure (additional enclosures/hard drives are available). When finished recording, simply eject the hard drive enclosure, and connect to a PC or Mac based system via USB). Work directly from the removable drive, or copy video files to your NLE's video drives. #DADN400320.....



**DN-600 • DN-700**

Table or Rackmount Hard Drive Recorder



Stores to an HDD or SSD in AVI and M2T formats. Includes two 2.5" enclosures and a 320GB HDD (1 slot available). Composite and DV/HDV FireWire I/O and balanced/unbalanced audio  
 DN-600 Tabletop Recorder with 320GB HDD (DADN600) .. **1440.00**  
 DN-700 Rackmount Recorder w/320GB HDD (DADN700) .. **1440.00**  
 Spare Hard Drive Enclosure (DAHDD25) ..... **48.00**  
 2.5" Spare HDD (DAHDD25SATA) ..... **144.00**

**HDR-45 • HDR-55**

HD/SD SDI HDD Recorders

Record via SDI, with HDMI output and SDI loop through. Offers a choice of 1080i, 720p, 576i and 480i recording formats. Record HD in either IBP or Intra-frame (i frame), and SD in IBP. Stores to an HDD or SSD in M2T Format. When recording is finished, hard drive enclosure ejects and can connect via USB to PC or Mac-based system. Includes RS-422, RS-232, and GPI for integration with other equipment.  
 HDR-45 Tabletop Recorder (DAHDR45) ..... **2016.00**  
 HDR-55 Rackmount Recorder (DAHDR55) ..... **2016.00**



<b>DAC-7</b> Analog to SDI Converter (DADAC7).....	<b>269.00</b>
<b>DAC-9P</b> HDMI to HD/SD-SDI Converter (DADAC9P).....	<b>283.00</b>
<b>DAC-50</b> HD/SD-SDI Signal Converter (DADAC50).....	<b>528.00</b>

**WIRELESS VIDEO TRANSMISSION**

**I.D. CW-5HD Cam-Wave**

HD Wireless Video Transmission System

Transmit HD 1080 signals wirelessly up to 100' through walls with less than 1ms transmission delay. Supports SD/HD-SDI video signal processing, multiple video formats, and two channels of SDI embedded audio. Operates via MIMO/OFDM, between 5.1-5.8 GHz —no FCC license required.



Is powered through its V-mount or 4-pin XLR. Selection of four manual or auto-select frequencies with 256-bit encryption. #IDC-W5HD..... **4895.00**  
 CW-5HDAB with Anton Bauer Bracket (IDCW5HDAB)..... **5449.00**

**witronix**

**Recon Wireless ULTRA**

Wirelessly transfer HD video 160' from a camera to a field monitor. The data is transferred uncompressed with a latency of less than a millisecond, allowing real-time monitoring in high quality. Whatever is being shot can be viewed as its being captured. The transmitted data is encrypted for safety.



Recon Wireless ULTRA with V-Mount (SWRU)..... **3064.95**  
 Recon Wireless ULTRA with AB Mount (SWRECALTRA)..... **3284.00**

**transvideo**

**Titan** Microwave Wireless Transmitter/ Receiver System

Perfect for use by all body-rig operators due to its stable signal even when in motion. Compact and lightweight, can be attached to any camera or monitor with hook and loop fasteners. Transmits and receives NTSC, PAL and SECAM color and B&W signals. Can broadcast through walls without resynchronization of the video. 1000' line of sight. (TRTTS)..... **2749.95**



**Cube**

Wireless HD Video

When combined with a Teradek decoder, Cube will transmit live video to any location with a data connection. Whether your video feed is being sent back to a studio, into a switcher, or displayed on a large screen, Cube's point to point streaming solution can bring your content to audiences worldwide. With a simple press of the Go Live! button, Cube will stream directly to your website, Facebook page, or a content delivery network (CDN) of choice. Cube supports multiple transport protocols, including RTMP, RTP/RTSP, RTP Push, MPEG-TS, and HTTP Live Streaming, which makes it the most versatile wireless video encoder available.

Cube-105 1-Ch. HD-SDI Encoder (TECUBE105).....	<b>1690.00</b>
Cube-155 1-Ch. HD-SDI Encoder with Wi-Fi (TECUBE155).....	<b>1990.00</b>
Cube-200 1-Channel HDMI Encoder (TECUBE205).....	<b>1190.00</b>
Cube-255 1-Ch. HDMI Encoder with Wi-Fi (TECUBE255).....	<b>1490.00</b>
18" Lemo to PowerTap Cable (TECUBIT118).....	<b>100.00</b>
18" 2-pin Lemo to PowerTap Adapter Cable (TEBIT118).....	<b>100.00</b>
Bond Cellular Transmitter (TEBOND).....	<b>2490.00</b>

**Cube Battery Adaptor Plate for:**

Canon LP-E6 (TECUBIT500).....	<b>100.00</b>
Sony L Series 7.2v (TECUBIT635).....	<b>125.00</b>

800-947-1186 | 212-444-6686

Production Switchers



**SE-500** Video Production Switcher

Four-input live production switcher with dual-output video mixer. Real time quad-split preview includes markers to indicate program, preview and other sources, as well as next selected effect. Equipped with special effects, audio mixer, Tally and MIDI I/O.

#DASE500 ..... **960.00**



**SE-600** 8-Input A/V Switcher

Switch seamlessly between video and audio sources and blend high-quality content on the fly. Multi-View output displays each input, as well as Program & Preview on one monitor. Features dual PIP functionality, audio delay, tally output, audio peak-meter, clock, and dual logo store. Output to two extra DV and two extra SD-SDI destinations with optional DV board.

**SE-600** (DASE600) ..... **1920.00** DV Output Card for SE-600 (DASE600DVIO) ..... **336.00**



**SE-2000** HD/SDI Digital Video Switcher

Offers up to 5 inputs by combining 1 or 2 DVI-D and 3 or 4 HD-SDI sources. PowerPoint presentations go right in through the DVI input. Multi display output includes each source, preview, program, and a digital clock display. Built-in audio mixer has 4 audio follows video inputs (mic or line) and two audio outputs. (DASE2000) ..... **3840.00**



**DataVideo Switcher Accessories**

- TD-LT** Tally Light (DATDLT) ..... **29.00**    **TD-1** Tally Light Set (DATD1) ..... **86.00**
- TB5** Tally Box for SE-500 (DATB5) ..... **144.00**    **900-YUV** Analog Input Card (DA900YUV) ..... **288.00**
- TLM-404H** Quad 4" LCD Monitor Bank (DATLM404H) ..... **1109.00**
- TLM-434H** Quad 4.3" HD LCD Monitor Bank (DATLM434H) ..... **2400.00**
- TLM-702** Dual 7" Color NTSC/PAL, 16:9/4:3 LCD Monitor Rack (DATLM702) ..... **816.00**
- TLM-702-HD** 7" Dual LCD Monitor Rackmount (DATLM702HD) ..... **1728.00**
- RKM-572** Holder Mount for TLM-702 on SE-500 Mixer (DARKM572) ..... **192.00**

**HS-500** Hand-Carried Video Studio

Integrated mobile video broadcast solution, consists of the SE-500 and TLM-702 housed in an aluminum carrying case that can be carried by hand. Offering true "live in seconds" performance, is ideal for use in educational institutions, houses of worship, streaming internet applications, events & live stage, and conferences, among many other potential applications. (DAHS500) ..... **2112.00**



**HS-2000** 5-Channel HD Mobile Studio

10-bit 1920 x 1080i or 1280 x 720p HD-SDI and DVI-D video & audio switcher with a 17" multi image video monitor displaying each source, together with preview and program. It offers a complete five way intercom system (supplied with five belt packs), 14 pre-stored logos, digital clock display, integrated audio mixer with balanced XLRs, title overlay and DVI-D connection for use with presentation software. (DAHS2000) ..... **7020.50**



**TriCaster 40**

**HD Multi-Camera Production Studio**  
Produce a broadcast-quality show from virtually any location. Integrates a 14-channel switcher, with four live camera inputs, multiview monitor,



digital disk recorder, program record storage, network inputs, streaming encoder, downstream keyer, professional titles and graphics, and 200 video transitions. Use multiple cameras, video inputs, stored clips, graphics, laptops, iOS devices and more to create and deliver television programming in real time at the native resolution of your video sources. Also features 24 virtual sets each with multiple camera angles, distinct set locations, moving backgrounds, active video monitors, real-time reflections, and over-the-shoulder double box effects. (NETC40) ..... **4995.00**

- TriCaster 40 Educational (NETC40E) ..... **4995.00**    TriCaster 8000 (NETC8000) ..... **39,995.00**
- TriCaster 455 (NETC455) ..... **19,995.00**    TriCaster LiveControl LC-11 (NELC11) ..... **1795.00**
- TriCaster 855 (NETC855) ..... **29,995.00**    Virtual Set Editor 2 (NEVSE22L) ..... **1495.00**
- LiveText 2 Titling Software (NELIVETXT2F) ..... **Call or Log-on**
- Control Surface for TriCaster 40 (NETC40CS) ..... **1995.00**
- Control Surface for TriCaster 40 Educational (NETC40CSE) ..... **995.00**



**V4 • V8** Video Production Switchers

Easy to use video mixers capable of switching between multiple cameras or tape decks during a live performance. Ideal for houses of worship, schools, and nightclubs, they employ high-quality digital 8-bit, 4:2:2 signal processing, and 2-channel TBC/ frame sync to ensure smooth transitions and stable images.

#ROV4 (Four analog inputs) ... **1275.00**    #ROV8 (Eight analog inputs) ... **2181.70**



**VR-3** AV Mixer

Mix multiple channels of audio, switch up to four channels of live video with effects, and stream the output to the web via USB. With computer video pass-through, it's perfect for events that require projection of a computer screen and a simultaneous live output stream. Four composite and VGA inputs. A touch-screen LCD makes it easy to monitor and switch sources as you keep track of program output. Audio effects include reverb, EQ, and low- & high-pass filters. 4 second delay ensures that audio is in perfect sync with your video. (ROVR3) **1995.00**



**VR-5** AV Mixer & Recorder

"All-in-one" solution greatly simplifies production, recording and streaming of any live event. Incorporates a video switcher, audio mixer, video playback, recorder, preview monitors and output for web streaming in a single unit. As a USB Video/Audio class device, web streaming is effortless by simply connecting to a computer running a live streaming service such as Livestream or USTREAM, as well as a video call service such as Skype and iChat. (ROVR5) ..... **4995.00**



**LVS-800** 8-Channel SD Video Mix/Live Switcher

Features downstream keyer (DSK), dual computer inputs, and multiple outputs. Mix between a variety of video sources including scan converters for PC inputs. Each bus can output different sources. Create exciting multi-screen environments for live events. Move from one source to another using dissolves or wipes. Add a professional touch by moving between sources in a variety of ways. Also offers RS-232 control and Picture-in-Picture display. (ROLVS800) ..... **3995.00**



**livestream Studio HD500**

**All-In-One Portable Live Production Switcher**  
Compact (12 x 17") portable production suite, the Studio HD500 incorporates a switcher and a full audio mixer with cross fade support. Switcher gives you real-time multiview, cut and fade, graphics overlay, video clip playback, and recording. 5 SDI inputs are available and all five can be used simultaneously when configured for streaming or recording. Blackmagic Quad and Studio Deck-Link cards come pre-installed and can be genlocked via two separate connectors. System includes mouse and keyboard, screen protector, and all fit in the Tom Bihn carry case. (LIHD500) ..... **8075.00**



**Panasonic AV-HS450N**

**16-Input HD/SD Switcher with Dual-Screen Multiviewer Display**

Equipped with 16 HD/SD-SDI inputs and four HD/SD-SDI outputs, along with two DVI-D outputs. Full 10-bit high definition processor produces unmatched image quality. When combined with optional boards, the switcher can be customized for almost any environment. All inputs can be displayed on two monitors. Additional features include AUX busses, up-conversion, full color correction, dual Picture-in-Picture display, two downstream keyers, chroma keyer, two 3D DVE's, and more. (PAAVHS450) ..... **Call or Log-on**



**SIMQ SFX-11** Digital Video Mixer

Offers up to 96 wipe patterns including circle, bar, cross-hatch, corner, etc., and digital effects like strobe, mosaic, paint, still, and negative. Features chroma and luminance keying techniques, while time-slip capabilities allow you to pause the viewing of a recorded video while the mixer continues to record. Using the joystick to control the mixer, PIP windows can be created and moved to any location on the display. (SISFX11) ..... **498.00**



**Sony MCS8M** Compact Audio Video Mixing Switcher (SOMCS8M) ..... **5395.00**



1x1 Composite Video Line Amplifier (KR101L).....	<b>104.00</b>
1:2 Composite Video DA (KRPT102VN).....	<b>88.00</b>
1:2 S-Video Distribution Amplifier (KRPT102SN).....	<b>88.00</b>
1:2 High-Resolution UXGA DA (KRVP200K).....	<b>112.00</b>
1:2 DVI Distribution Amplifier (KRVM2HDPCXL).....	<b>280.00</b>
1:2 HDMI Distribution Amplifier (KRVM2HXL).....	<b>236.00</b>
1x2 3G HD-SDI Distribution Amplifier (KRVM2HDXL).....	<b>392.00</b>
1x3 Differential Video Line Amplifier (KR123VXL).....	<b>144.00</b>
1x3 Composite Video DA (KRPT103V).....	<b>120.00</b>
1x3 Composite Video & Stereo Audio DA (KRVM30AVB).....	<b>192.00</b>
1x3 Composite Distribution Amplifier (KRVM3VN).....	<b>140.00</b>
1x3 Computer Graphics Video DA (KRVP300K).....	<b>200.00</b>
1x4 SDI & HD-SDI (HDTV) Video DA (KRVM4HD).....	<b>428.00</b>
1x4 3G HD-SDI Video DA (KRVM4HDXL).....	<b>476.00</b>
1x4 HDMI DA (KRVM4HXL).....	<b>396.00</b>
1x4 Composite Line Amp with differential input (KR104LN).....	<b>144.00</b>
1x4 RF Distribution Amplifier (KR104R).....	<b>100.00</b>
1x4 DVI Distribution Amplifier (KRVM4HDPCXL).....	<b>428.00</b>
1:4 XGA Line Transmitter and DA (KRTP104HD).....	<b>196.00</b>
1x4 Computer Graphics Video DA (KRVP400K).....	<b>236.00</b>
1x5 Composite Video, Stereo Audio DA (KRVM5S).....	<b>292.00</b>
1x5 Composite Video DA w/Gain and EQ (KRVM51).....	<b>208.00</b>
1x5 VGA to UXGA DA (KRVP5XL).....	<b>316.00</b>
1x10 Balanced Audio DA (KRWM1110XL).....	<b>528.00</b>
UXGA to Composite (2) and S-Video (2) (KRVP701XL).....	<b>760.00</b>
UXGA to Composite and S-Video converter (KRVP501XL).....	<b>396.00</b>
UXGA to Composite and S-Video converter (KRVP502XL).....	<b>440.00</b>
2x1 XGA switcher (KRPT201VGA).....	<b>88.00</b>
2x1 XGA switcher, 1x4 DA (KRVP242).....	<b>180.00</b>
2 x 1 Computer graphics video switcher (KRVP222K).....	<b>140.00</b>
2 x 1 Automatic HDMI Standby Switcher (KRVS211H).....	<b>212.00</b>
4x1 Mechanical switcher (KR4X1VB).....	<b>132.00</b>
4x1 Balanced Stereo Audio Switcher (KRVS4X).....	<b>192.00</b>
4 x 1 HD-SDI switcher (KR6241HD).....	<b>636.00</b>
4x4 CG video & balanced stereo switcher (KRVP4X4K).....	<b>796.00</b>
16 x 16 video matrix switcher (KRCVG162V).....	<b>1560.00</b>
7-input analog & HDMI scaler & switcher (KRVP437XL).....	<b>1036.00</b>
9-input presentation scaler/switcher (KRVP729).....	<b>1356.00</b>
9-input presentation scaler/switcher (KRVP730).....	<b>1596.00</b>
10-input Analog & HDMI ProScale Presentation Digital Switcher (KRVP438).....	<b>1036.00</b>
PT-571 HDMI over Twisted Pair Transmitter (KRPT571).....	<b>188.00</b>
WUXGA Transmitter over CAT-5 with EDID (KRPT110EDID).....	<b>188.00</b>
XGA Line Receiver over CAT-5 Cable (KRPT120).....	<b>168.00</b>
VGA/UXGA Line Receiver over CAT-5 Cable (KRTP120).....	<b>156.00</b>
HDMI over CAT-5 cable receiver (KRPT572P).....	<b>212.00</b>
DVI & Audio to HDMI format converter (KRFC49).....	<b>360.00</b>
FireWire Range Extender (KRTP300FW).....	<b>180.00</b>
CG video & stereo audio standby switcher (KRVP211K).....	<b>180.00</b>
TR-1 Video Isolation Transformer (KRTR1).....	<b>96.00</b>
RK-80N rack adapter kit (KRK1).....	<b>76.00</b>
RK-3T rack adapter (KRK3T).....	<b>40.00</b>
VA-256XL Audio Delay (KRVA256XL).....	<b>520.00</b>



USB VGA KVM Console Extender (IOGCE500U).....	<b>222.99</b>
USB Xtra Booster Ethernet Extender (IOGUCE61).....	<b>39.99</b>
GVE320 HD Extender with CAT5e/6 (IOGVE320).....	<b>70.54</b>



1x2 HDMI DA with 3D Support (ATHDV12).....	<b>204.99</b>
1x2 VGA DA with Audio and Constant Power (ATVGA12A).....	<b>150.39</b>
1x4 VGA DA with Audio (ATVGA14A).....	<b>178.20</b>
1 x 4 HDMI Splitter (ATATHDV14SS).....	<b>649.99</b>
2x1 VGA + Analog Stereo Audio Switcher (ATAPC21A).....	<b>124.12</b>
4x1 VGA + Analog Audio Switcher (ATPC41A).....	<b>187.00</b>
4 x 2 HDMI Switcher (ATHD4V42).....	<b>346.99</b>
10x1 Switcher / Scan Converter w/HDMI out (ATHD600).....	<b>359.99</b>
AT-DVI60SRS DVI Passive Extender Kit (ATDVI60SRS).....	<b>158.19</b>
DVI to VGA / Component Scaler with DVI out (ATPC530).....	<b>280.50</b>
VGA / Stereo Audio CAT5 Extender Receiver (ATVGA300RL).....	<b>139.99</b>
HDMI Extender with 3D Support (ATATHD4V40SR).....	<b>329.99</b>
HDMI/DVI to Comp. S-Video Downconverter (ATHD530).....	<b>299.99</b>
HDMI Up/Down Scaler and (ATHD550).....	<b>199.99</b>
HDMI to VGA / Component & Audio Converter (ATHD420).....	<b>164.78</b>
3G/HD/SD-SDI to HDMI Converter (AT3GSDIHD2).....	<b>399.99</b>
Composite Video to VGA Format Converter (ATRGB110).....	<b>109.99</b>
Composite / S-Video / Dual HDMI Input Scaler (ATHD580).....	<b>349.99</b>
Component or VGA Scaler /Converter (ATAVS100).....	<b>142.37</b>
PC / Laptop to HDMI Converter with Scaler (ATHD500).....	<b>184.95</b>
PAL HDMI to NTSC HDMI Converter (ATHD560).....	<b>163.00</b>
USB Powered VGA to HDMI Scaler/Converter (ATHDVIEW).....	<b>149.99</b>
Composite & Stereo to HDMI Converter/Scaler (ATHD120).....	<b>150.99</b>
PC / Component to HDMI Scaler (ATHD510VGA).....	<b>272.50</b>
VGA to Component / Component to VGA Converter and Scaler (ATVGA300CV).....	<b>299.99</b>
Component Video Downconverter (ATCOMP500).....	<b>268.99</b>
Composite, S-Video to HDMI Converter Scaler (ATHD520).....	<b>240.99</b>
VGA to HDMI Scaler/Converter (ATHDVIEW50).....	<b>135.63</b>
SDI to PC/HD Scaler with Audio (ATHSDIVGA).....	<b>791.44</b>
11 Input Scaler and Switcher (ATLPRO5GEN2).....	<b>965.40</b>
DVI Over Single CAT5e Mini-Extender (ATDVI15SRS).....	<b>99.99</b>
High Speed HDMI Extender Kit (ATHD4SI40SR).....	<b>190.46</b>
HDMI Audio De-Embedder with 3D Support (ATHD570).....	<b>155.99</b>
HDMI CAT5 Receiver - up to 50' (ATATHD15SRS).....	<b>66.99</b>
HDMI CAT5 Receiver - up to 200' (ATHDRS).....	<b>154.99</b>
HDMI Extender Kit with Full 3D Support (ATHD4V110SR).....	<b>511.99</b>
Passive VGA Extender over CAT 5/6/7 Cable (ATVGA100R).....	<b>65.59</b>
VGA with Stereo Audio and RS-232 Extender over Single CAT5/6 up to 1000' (ATVGARS300SR).....	<b>389.95</b>

<b>Aluratek</b> VGA to HDMI Adapter w/Audio (ALAVH100F).....	<b>82.99</b>
<b>SIIG</b> 1x2 VGA Splitter (SICEV).....	<b>26.50</b>
<b>SIIG</b> 1x4 VGA Splitter (SICEV60D11S1).....	<b>30.99</b>
<b>SIIG</b> 1x8 VGA Splitter (SICEVGOE11S1).....	<b>44.95</b>
<b>SIIG</b> 2x2 VGA & Audio Matrix Switcher (SICEVGOK11S1).....	<b>59.95</b>
<b>Vitek</b> 1x4 Video DA (VIVTAD104).....	<b>45.00</b>
<b>Vitek</b> 1x8 Video DA (VIVTAD108).....	<b>64.95</b>



1x4 Composite & Stereo Audio DA (AVAVT4714).....	<b>92.65</b>
Quad Splitter with TBC (AVAVT8120).....	<b>254.15</b>
Component to CS/SV Down Converter (AVVS223).....	<b>237.15</b>
AVT-3155A Scan Converter (AVAVT3155A).....	<b>126.65</b>
AVT-3160 Scan Converter (AVAVT3160).....	<b>169.15</b>
AVT-3190 Scan Converter (AVAVT3190).....	<b>420.75</b>
Multi-Standard Time Base Converter (AVAVT8710).....	<b>228.65</b>
CDM-660 Standards Converter (AVCDM660).....	<b>237.15</b>
Analog Video to UXGA Scaler (AVAVT3320).....	<b>84.15</b>
CS/SV to HDMI Up Converter (AVVS612).....	<b>216.75</b>
PC Signal Distribution Amplifier (1x4) (AVAVT4214A).....	<b>64.95</b>
AVT-3420 Video Scaler (AVAVT3420).....	<b>135.15</b>
CS-320 Scan Converter (AVCS320R).....	<b>244.95</b>
POF-820 Coaxial-to-Optical Audio Converter (AVPOF820).....	<b>16.15</b>



1x2 HDMI Distribution Amplifier (COCDAMD100).....	<b>39.99</b>
1x2 Composite Video Distribution Amplifier (COCDAV200).....	<b>71.99</b>
1x2 Component Video DA (COCDACV20).....	<b>116.99</b>
1x3 Audio/Composite Video DA (COVM30AVB).....	<b>154.99</b>
1x4 High-Resolution VGA DA (COCDAVGA104H).....	<b>46.99</b>
1x4 High-Resolution VGA DA (COCDAVGA108H).....	<b>60.99</b>
1x4 HDMI Distribution Amplifier (COCDAMD200).....	<b>37.24</b>
1x4 HDMI Distribution Amplifier (COCDAMD400).....	<b>76.79</b>
1x5 Composite Video Distribution Amplifier (COCDAV50).....	<b>119.00</b>
2x1 XGA / Stereo Audio Switcher (COCSWVGA211).....	<b>145.99</b>
4x1 VGA / XGA Mechanical Switcher (COVP41).....	<b>224.00</b>
4x2 HDMI Digital Switcher (COCSWHD420).....	<b>95.99</b>
HDMI Splitter & Extender Over Single CAT-5 (COCHE1).....	<b>108.79</b>
HDMI Splitter & Extender Over Dual CAT-5 (COCHE2).....	<b>75.99</b>
CAT-5 Single Source/Display VGA Extender (COCVETRX01).....	<b>89.24</b>
AB 2-Position Switch Box (COCSWMBNC12).....	<b>19.99</b>
VGA & Audio to HDMI Converter (COCCNH101).....	<b>47.99</b>
RCA & Audio to HDMI Converter (COCCNH101).....	<b>47.99</b>
Composite/S-Video to HDMI Converter (COCCNCSH101).....	<b>79.99</b>



1 x 2 HDMI Mini Splitter with Full HD 1080p (KAHD2PSPB).....	<b>55.80</b>
1 x 2 VGA Splitter with audio (KAVGA1X2SP).....	<b>59.95</b>
1 x 2 VGA Extender over CAT5/6 w/Audio KAVGAEXTX2).....	<b>224.95</b>
1 x 2 HDMI Splitter with CAT5/6 outputs (KAHD2PSPPE).....	<b>148.65</b>
1 x 4 HDMI Splitter with CAT5/6 outputs (KAHD4PSPPE).....	<b>249.95</b>
1 x 4 HDMI Mini splitter with 1080p (KAHD4PSPM).....	<b>79.95</b>
1 x 4 VGA Splitter with audio (KAVGA1X4SP).....	<b>102.35</b>
1x8 HDMI to CAT5/6 DA (KAHDMISPBBE).....	<b>359.50</b>
1x8 DVI Splitter with Full HD 1080p (KADVSP8HD).....	<b>650.00</b>
2 x 2 HDMI Switcher with built-in splitter (KAHDMX22).....	<b>74.95</b>
2x4 HDMI Splitter with full HD 1080p (KAHDS2PX4).....	<b>117.50</b>
4 x 1 HDMI Switcher (KAHDSW4HF).....	<b>56.50</b>
4x2 HDMI Matrix Switcher with Signal EQ (KAHDMX42AU).....	<b>155.00</b>
5 x 1 HDMI Touch Switcher (KAHD5XSW).....	<b>65.15</b>
HDMI to VGA with audio converter (KAHDVGARL).....	<b>64.99</b>
HDMI to composite with audio converter (KAHDRCA).....	<b>88.35</b>
HDMI to component converter w/ audio (KAHDRGBRL).....	<b>68.85</b>
Digital to analog audio converter (KAAUD2ACV).....	<b>33.59</b>
Composite or S-Video to HDMI converter (KAHDCVRYW).....	<b>69.75</b>
Component to HDMI audio/video converter (KARGBRLHD).....	<b>69.75</b>
VGA to HDMI with audio converter (KAVGARLHD).....	<b>69.95</b>
165' HDMI extender over CAT 5e/6 (KAHDEX50M).....	<b>57.99</b>
1000' VGA ext. over CAT5/6 w/Audio (KAVGAEXTX1).....	<b>139.95</b>
DVI with RCA audio to HDMI converter (KADVIRLHD).....	<b>60.00</b>
Component with SPDIF to HDMI Converter (KAHDRGBTOS).....	<b>63.58</b>
Mini DisplayPort to HDMI 2x Converter (KAMDPHD2X).....	<b>69.95</b>
HDMI Repeater with 3D Support (KAHDREPEAT3D).....	<b>22.50</b>
Analog to Digital Audio Converter (KAUA2DCV).....	<b>25.99</b>
USB 2.0 Single Extender Over Twisted Pair (KAUSBEXTRJ45).....	<b>48.99</b>
AV 1x4 1000' Ext. w/VGA & CAT5e/6 (KAVGAEXTX4).....	<b>372.25</b>



**High-Definition Baluns (in pairs)**

Digital Audio and Component Video (INAVOV3ADPAC) .....	152.18
HD Component Video (INAVOV3HDPAC) .....	116.06
Stereo Analog Audio (INAVOA2PACF) .....	105.74
Stereo Analog Audio -Single (INAVOA2F) .....	52.42
Stereo Audio & S-Video (INAVOSVA2PAC) .....	122.08
Composite Video (INAVOV1PACF) .....	42.96
Stereo Audio & Composite Video (INAVOV1A2PAC) .....	Log-on
AVO-VGA Passive VGA Balun-Pair (INAVOVGA) .....	153.86
VGA-HR-F Modular Balun System (INVGAHRF) .....	285.00
AVO-USB Extender Set (INAVOUSB) .....	68.76
HDMI and IR Extender System (INDIGHDIR2) .....	343.96
DIGI-HDMI-HR Balun-Pair (INDIGHDMIHR) .....	214.96
HDMI Over Twisted Pair System (INDIGHDMIU2) .....	300.96
AVO-USB- C Client Side USB Extender (INAVOUSBC) .....	24.99
HDMI over Coax Transmitter (INDHDCOAX2S) .....	257.95
HDMI over Coax Receiver (INDHDCOAX2R) .....	343.96



1x2 RGBHV Distribution Amplifier (TV1TVGA412) .....	80.75
1x4 RGBHV Distribution Amplifier (TV1TVGA414) .....	140.25
1x8 Composite Video DA (TV1TDA8CVB) .....	140.25
Scan/Down Converter (TV1TC2100) .....	675.75
Dual-PIP DVI-I Scaler (TV1TC2750) .....	845.75
Bi-directional PC-HDTV Scaler (TV1TC2400) .....	335.75
DVI to RGB Converter (TV1TFC425) .....	135.15
Multi-Standard Time Base Corrector (TV1TBCGL) .....	420.75
CAT6 to HDMI Receiver (TV1TCT632) .....	110.50
Universal Video Switcher/Scaler (TVC22355A) .....	2970.75
1T-DA-654 HDMI Distribution Amplifier (TV1TDA654) .....	335.75
1T-C2-250 Video Scaler with Corio (TV1TC2250) .....	420.75
1TV1280DVI Video Upconverter (TV1TV1280DVI) .....	254.15

**MuxLab**

Stereo Audio Balun (MUSAB) .....	33.01
500030 Stereo PC-Audio Balun (MUSPCAB) .....	31.95
500026 MonoPro XLR-F (MUMPLRFR) .....	22.95
Component Video/Audio Balun (MUCVAABM) .....	64.95
Dual Audio-Video Balun (MUDAVB) .....	54.15
Stereo AV/IR Pass-Thru Balun (MUSAVIRPTBM) .....	51.48
Stereo Hi-Fi Balun (MUSHB) .....	42.80

**Ocean Matrix**

1x4 HDMI HDCP compliant DA (OCOMXHDMI1X4) .....	149.99
Composite Video BNC AB switch (OCOMXVIDEO2A) .....	35.65
VHE-125-HD Video Hum Eliminator (OCVHE125HD) .....	129.55
HDMI over CAT-5 System (OCOMXHDMICAT) .....	79.99

**Sescom**

RCA Stereo Audio A/B Switch (SESAUDIOAB) .....	35.96
Stereo Audio A/B Switch (SESM3RCAAB) .....	54.95
Balanced Audio Pro Grade XLR A/B Switch (SESXLRAB) .....	45.85

**Smart-AVI**

HDS-2P HDMI 2 x 1 Splitter (SMHDS2P) .....	159.95
Component/VGA + Audio to HDMI (SMCVH01S) .....	184.00
DVX-RX200 DVX Receiver (SMDVXR200S) .....	179.90
XT-PROS UXGA Extender (SMXTPROS) .....	344.95

**Shinybow**

1 x 2 Composite Audio / Video DA (SHSB3772) .....	45.38
1 x 2 Component Video DA (SHSB3776BNC) .....	99.95
1 x 4 Composite Video DA (SHSB3701BNC) .....	59.49
1 x 8 HDMI Splitter / DA (SHANIO108HC) .....	403.00
SB-3690 Multi Video Digital Converter (SHSB3690) .....	126.30

**Vitec Multimedia Extensor™ Mini-Converters**

ANA2SDI (VIEXTANASDI) .....	795.00
HDMI2SDI (VIEXTHMISDI) .....	795.00
SDI2ANA (VIEXTSDIANA) .....	795.00
SDI to SDI (VIEXTSDISDI) .....	495.00
HD SCALER (VIEXTHSCALE) .....	4995.00



1x2 VGA Hub (GE1X2VH) .....	Call or Log-on
1x2 Digital Audio Splitter (GE1X2DAS) .....	51.31
1x2 Dual-Link DVI Splitter (GE1X2DDLSDA) .....	222.19
1x2 Splitter for HDMI 1.3 with Digital Audio (GE1X2HSD) .....	191.82
1x3 Splitter for HDMI 1.3 (GE1X3HS) .....	232.99
1x3 Component Video & Audio DA (GEEXTCOMPAU3) .....	131.62
1x4 Splitter for HDMI 1.3 (GE1X4HS) .....	264.04
1x4 HDMI Splitter (GE1X4H13) .....	193.46
1x4 DVI Distribution Amplifier (GEEXTDVI144N) .....	319.03
1x4 Splitter for HDMI with FST (GE1X4H13B) .....	197.99
1x4 VGA Hub (GE1X4VH) .....	Log-on
1x8 VGA CAT5 Distribution Receiver (GE1X8DR) .....	78.16
1x8 VGA Cat-5 DA (GE1X8DS) .....	442.11
1x10 HDMI DA (GE1X3HDA) .....	473.03



Gefen  
EXT-VGA-145  
1x4 VGA Hub

4x1 3G-SDI Switcher (GE4X1SS) .....	440.33
4x1 HDMI Switcher (GESH4X1) .....	131.62
VGA-to-DVI Scaler (GECARGDVS) .....	Log-on
DVI over CAT-6 Cable Extender (GEDC6) .....	394.00
DVI-Audio-to-HDMI Adapter (GEDVAHDC) .....	Log-on
DVI to HD-SDI PLUS Scaler Box (GEDVHSDICSG) .....	Log-on
DVI to HD-SDI Scaler (GEDVHSDICSG) .....	Log-on
DVI over Fiber Extender (GEDF1640) .....	437.95
DVI to HD-SDI Converter (GECSDSHS) .....	Log-on
Dual-Link DVI over Fiber Extender (GEDEDL) .....	1047.99
HDMI-to-DVI Audio Adapter (GEFDC) .....	Log-on
HDMI to Composite Scaler (GESHC) .....	190.74
HDMI 1.3 over CAT-6 Cable Extender (GEEHC6) .....	393.00
HDMI 1.3 to 3G-SDI Converter (GECHS) .....	679.00
CAT5-1000 Transmitter/Receiver Kit (GEEXTCAT5100) .....	442.95
RS-232 Serial Extender (GEEXTRS232) .....	81.00
USB 2.0 Extender (GEEXTUSB20LR) .....	326.00
Mini USB-2.0 Extender (GEMU2EC5) .....	139.95
AUD-1000 Analog Audio Extender Kit (GEEXTAUD1000) .....	80.17
330' HDMI Extender Over Cat-5 (GEEC5C) .....	433.89
2x VGA Extender (GE1X2VE) .....	256.77
VGA SR Extender (GETRVGA) .....	131.62
VGA with Audio to HDMI Scaler (GESVA) .....	Log-on
VGA Video & Audio Serial Extender Set (GEVAE) .....	225.37
VGA Video Extender (GEEXTVGA141L) .....	187.90
VGA-to-DVI Scaler (GECARGDVS) .....	Log-on
Component Video & Analog Audio to HDMI (GECVAHC2) .....	Log-on
Composite to HDMI Scaler (GECHEMIS) .....	197.03
Fiber Optic DVI Extension Module (GEEVIFC) .....	629.99
Composite Video & Analog Audio Extender Kit with Sender and Receiver (GEEXTCOMPOS) .....	162.95
4x4 DVI Dual-Link Matrix (GE4X4DS) .....	544.48
4x4 Matrix for HDMI (GEGTBHDFST44) .....	583.64
Multi-Format Switcher (GEMFS) .....	339.49
1:8 Splitter for HDMI with FST and 3DTV (GE1X8HSB) .....	342.49
ToolBox High Definition 1080p Scaler (GEGHD1080PSB) .....	247.00
Digital Audio Extender Kit (GEDIKAUD141) .....	134.10
FireWire-800 Extender Plus (GEEFW) .....	616.79

Analog Way Quattro Value Switcher (ANQXE421) .....	3147.50
Avenview 1X2 HDMI Splitter (AVSHDM3D2) .....	58.65
Avenview 1X4 HDMI Splitter (AVSHDM3D4) .....	84.15
Barco DCS-200 Dual-Channel Switcher (BADCS200) .....	4949.95
Barco ImagePRO-3G Signal Processor (BAIPH1080P) .....	6499.95
Datavideo VP-299 A/V DA (DAVP299) .....	115.00
Datavideo TBC-1000 Single Channel TBC (DATBC1000) .....	480.00
Datavideo AD-100 Audio Delay Box (DAAD100) .....	422.00
Matrox Dual SDI to HDMI for 3G/HD/SD (MAMC100SH) .....	495.00
Sima HDMI to Component Converter (SIXCONYUV) .....	209.95
TecNec AV61 Distribution Amplifier (TEAV61) .....	103.18
Orion Images HD-SDI Receiver (ORCSHDHRC) .....	299.95



**Noise Eliminators & Isolators**

HEC-2000 Video Hum Eliminator (ALHEC2000) .....	129.95
HEC-2000H Video Hum Eliminator (ALHEC2000H) .....	134.95
HEC-3000 Video Hum Eliminator (ALHEC3000) .....	374.95
HEC-5000 Video Hum Eliminator (ALHEC5000) .....	595.00
VIT-75 Isolation Transformer (ALVIT75) .....	119.40
HD-SDI Video Hum Eliminator (ALHSDSI) .....	244.95

**Black Burst & Pattern Generators**

Atlona Pattern generator (AT3GSDI500) .....	1131.12
Atlona Portable HDMI signal generator (ATHD800) .....	325.11
Kramer 810 color bar generator (KR810) .....	236.00
Kramer 811 VTest Pattern and Audio Generator (KR811) .....	716.00
TV One HDMI test generator (TV1TTG620) .....	254.15

**Time Code Generators & Readers**

Ambient Recording ACC-501 Controller Master Clock (AMACC501) .....	1348.00
Denecke SB-3 Syncbox (DESB3) .....	467.50
Denecke SB-T Time code & video sync generator (DESBT) .....	892.50
Horita PTG Portable time code generator (HOPTG) .....	409.95

**Video Patchbays**

**Canare**

161U-BJRU AV Bulkhead Panel (CA161UBJRU) .....	144.95
20DV 2x20 Digital Video Patchbay (1RU) (CA20DV) .....	597.13
24DV 2x24 Digital Video Patchbay (1RU) (CA24DV) .....	736.95
24DV-2U 2x24 Digital Video Patchbay (2U) (CA24DV2U) .....	785.95
32MD-ST Mid-size HD-SDI Patchbay (CA32MDST) .....	1099.00

**TecNec**

16XB Patchbay (TE16XB) .....	99.95
------------------------------	-------



**Edge Green**

**High-Definition Video Processor**



Converts SD, HD and PC signals from up to nine sources (including five HDMI) to any HDTV up

to 1080p. It has two HDMI outputs, one with audio and video and one audio-only to facilitate connections to an HDMI/DVI equipped display and HDMI AV receivers. (DVEDGE101LC) .....

399.00

iScan Duo High-Definition Video Processor (DVISDUO) .....

899.00

**TASCAM BD-R2000**

**Rackmount High-Def Blu-Ray/DVD Recorder**



Incredibly versatile, the BD-R2000 records to HDD, SD card, DVD and Blu-Ray disc. It captures standard or HD video and integrates editing functions. Features FireWire, S-Video, and USB connectors, HDMI and optical audio out, single-touch dubbing and wired and wireless remote control. (TABDR2000) .....

2199.99

**TASCAM DV-D01U**

**Rackmount Studio DVD Player**



Reads and plays wide variety of formats, including DVD, DVD Audio, CD-DA, MP3, WMA, WAV, DivX, MPEG-2, and more. RS-232 interface allows it to be controlled remotely in a studio. #TADV01U .....

389.99

**AT-DIS7-PROHD**

7" Pro HD Monitor Rack Mount Monitor

- Use to test the cabling and installation of equipment from a remote location.
- Compatible with HDMI, DVI, VGA, or component video sources
- Supports resolutions up to 1080p • Built-in speakers

#ATDIS7PROHD..... **429.99****DELV-MLCD35RM**

3.5" Quad Rackmount LCD Series Monitor



Provides an easy way to monitor up to 4 feeds simultaneously in a compact 2 RU high unit. Each feed features front and rear video inputs with a button to switch back and forth. Additionally, the front panel features a power button, menu, and menu up/down arrows for each of the 4 LCD screens. The unit is housed in a lightweight yet durable black anodized aluminum housing.

#DELVMLCD35RM..... **539.95****DELV-2LCD-7XLRM**

Dual 7" LCD Rackmount with TV Tuner

4RU high, monitors feature 1440 x 234 resolution, BNC composite input with NTSC/PAL auto select, and image-flip mode. Monitor 'A' has a built-in 255-channel TV tuner. Includes base support / table top stand, AC and DC adapter, and remote control. (DE2LCD7XLRM).....

**399.95****DELV-RCLCD**

Dual 7" Rackmount LCD Monitor



Housed in lightweight anodized aluminum 19" rackmount enclosure, each screen features 800

x 600 resolution, and front and rear

BNC video inputs (NTSC/PAL auto switching and detection) with tracking loop output. Includes 12v DC power supply, but can be powered by any 12v DC source. (DEDELVRCLCD).....

**269.00**ULCD-1 Adjustable Depth LCD Rackmount (DEULCD1)..... **33.60**ULCD-2 Universal LCD Rackmount (DEULCD2)..... **25.50****Ikegami HLM-1704WR**

17" HDTV Multi-Format LCD Color Monitor

1280 x 768 monitor that runs on AC and DC power for maximum versatility. Features DVI-D and dual HD/SD-SDI input, user-defined screen markers, waveform monitor, vectorscope, timecode display, and compatibility with nearly any resolution and standard frame rate. 7RU high, ideal for sub-control rooms, editing facilities, monitor walls, transmission control desks, and OB vans. (IKHLM1704WR).....

**1999.95****Marshall****V-R43P • V-R44P**

Triple or Quad 4" LCD Rack Mountable Monitor



- 480 x 234 resolution on each monitor
- Each has two composite BNC video inputs with an active loop-through and can auto-detect NTSC and PAL signals
- Three different color tally indicators above each LCD panel
- Dry erase marking area to identify camera angles or programs
- Contrast, color, brightness, and tint controls

#MAVR43P (Triple LCD Monitor)..... **1006.25**#MAVR44P (Quad LCD Monitor)..... **1263.85****V-R653P-HDSDI**

Triple 6.5" LCD Rack Mountable Monitor

- 800 x 480 resolution on each monitor
- HD/SD-SDI input/output per monitor



- Contrast, color, brightness controls
- Blue only mode

#MAVR653PHDSDI..... **3103.85****V-R573P Triple 5.7" LCD Panel**

Tilttable, rackmountable (3RU) unit with three 960 x 234 resolution displays. Offers two composite video inputs/outputs per screen, as well as a built-in color bar generator, tally system, and NTSC/PAL switchability. Front-mounted image controls and LED indicators add to its functionality, which make it ideal for control rooms, CCTV, and OB van applications.

#MAVR573P..... **1378.85****V-R185-IMD-3GTE**

18.5" Rackmount LCD with 3G-SDI and IMD

On-screen tri-color tally displays eliminate the need for external displays. Also on-screen are an audio presence indicator and video time code, both detected

from SDI auxiliary data stream. Tri-color hard tally LEDs are available and can be controlled via the RS-422 / 485 ports or DB-15 connector. Easily integrates with existing tally systems and controllers. Connections include a 3G/HD-SDI input and output. 6RU high, the monitor comes with removable rack ears and ships ready to rack mount, but it can also be wall or ceiling-mounted with an optional VESA adapter. (MAVR185IMD3G).....

**1148.85****Additional Marshall Monitors & Accessories**V-LCD102-ATSC 10.2" Monitor (AVLCD102ATS)..... **297.85**V-LCD110-ATSC 11" Field Monitor (MAVLCD110ATS)..... **297.85**

V-R151DP-AFHD 15" HD Desk/Rackmount LCD

(MAVR151PAFHD)..... **1677.85**DVI-I Input Module ('A'-type) (MAMDDVIA)..... **166.75**3G-SDI Input Module with Loop-Out (MAMD3GE)..... **320.85**Dual HD-SDI Input Module (MAMDHSDIX2A)..... **412.85****DT-E17L4G**

17" Multi-Format HD LCD Monitor

Full HD 1920 x 1080 resolution, 600:1 contrast ratio and 10-bit color processing. Inputs and outputs include HD/SD-SDI and HDMI. LED backlighting for improved contrast and black level. Built-in speakers and 16-channel embedded audio with a level indicator. Low latency, area / center / safety markers, LTC and VITC time code support, and an In-Monitor Display function (IMD).

#JVDE17L4GU..... **2395.00****DT-R24L41DU 24" Studio Monitor**

- 1920 x 1200 resolution
- 1080/24psf capability
- 10-bit 4:4:4 processing
- 1:1 monitoring mode
- 900:1 contrast ratio
- 12-channel audio meter
- HD/SD-SDI, DVI-D, and composite inputs and output
- Display LTC and VITC TC
- Built-in speakers
- Area markers and a 100%-80% adjustable safety marker
- External control via RS-232C, RS-485 and Make/Trigger

#JVDR24L41DU..... **Call or Log-on****DT-V17G1Z 17" Studio Monitor**

Same features as the DT-R24L41DU PLUS –

- 3G / Dual-Link ready for monitoring of 60 frames/ 2.97Gbit per second uncompressed 1080p digital video
- De-interface (IP mode) circuitry
- Ultra-Low Latency Circuitry (< 1 frame) for lip-sync accuracy.
- Built-in waveform monitor and vectorscope
- View HD-SDI / SDI embedded time code on the screen

#JVDTV17G1Z..... **2695.00**17" Verite G-Series HD LCD Monitor (JVDTV17G1S2)..... **3995.00****PN-E521 52" Full Color LCD Monitor**

Full HD 1080p in a sturdy, lightweight design. Made for continuous 24-7 use, the monitor's thin bezel, portrait/landscape orientation, and fanless operation ensure it remains quiet and unobtrusive in any number of settings, from video conference rooms to traffic control centers, houses of worship, and digital signage venues. HDMI and analog/digital RGB inputs, plus has a modular expansion slot that allows for increased inputs via the optional PN-ZB01 board. An optional signage controller is also available, which attaches easily to the back, with video walls of up to 5 x 5 possible. #SHPNE521..... **Call or Log-on**

800-947-1186 | 212-444-6686

Production Monitors

**SONY**

**LMD-940W** 9" ENG/EFP LCD Monitor

- 800 x 480 (WVGA)
- Selectable 4:3 / 16:9
- Mono speaker
- Adjustable color temperature
- Parallel Remote
- Various area markers,
- Removable protection panel
- Mono/ Blue only mode; Scan Mode (Over, Full, Native)



#SOLMD940W..... **Call or Log-on**

**LMD-1530**

15-inch WXGA HD Monitor with HDMI

- HDMI, composite (NTSC/PAL), S-Video, component and RGB input
- SD-SDI input via optional BKM-320D adapter.
- Center marker and aspect markers with selectable brightness.
- Selectable color temperatures and gamma modes



#SOLMD1530W..... **Call or Log-on**

**SONY**

**High-Grade LUMA SERIES**

15-, 17- and 24" Professional HD Monitors

- They incorporate the latest DSP engine, ChromaTRU color-matching technology, and high functionality.
- Composite (NTSC/PAL), S-Video, component and RGB input. Optional HD-SDI and SD-SDI digital interfaces are also available.



- Center marker, aspect markers, and a safety zone marker
- Selectable color temperatures, scan size and aspect ratio
- Can be controlled remotely via parallel & serial remote connector

- LMD-1541W:** 15" LCD Monitor (SOLMD1541W)..... **2599.95**
- LMD-1510W:** 15.6" LCD Monitor (SOLMD1510W)..... **769.95**
- LMD-1751W:** 17" LCD Monitor (SOLMD1751W)..... **2899.95**
- LMD-2451W:** 24" High Grade Monitor (SOLMD2451W)..... **3895.00**
- BKM-320D SDI Input Adapter (SOBKM320D)..... **374.95**
- BKM-243HS HD-SDI Input Adapter (SOBKM243HS)..... **1099.95**

**Additional Sony Monitors & Accessories**

- LMD-2110W:** 21.5" LCD Monitor (SOLMD2110W)..... **899.95**
- PVM-1741:** 17" OLED Picture Monitor
- Incorporating Super Top Emission technology, the OLED display panel delivers excellent black performance, quick response with minimal motion blur, and a wide color gamut. RGB panel driver supports 10-bit color depth for high image quality. Uses an optical resonance effect in combination with color filters to enhance color purity and improve light emission. It supports color standards such as ITU-R BT.709, EBU, and SMPTE-C. (SOPVM1741A)..... **3690.00**
- PVM-2541:** 25" OLED Monitor (SOPVM2541)..... **5490.00**
- PVM-X300** 30" 4K TRIMASTER Monitor (SOPVMX300)..... **31,679.95**

**Marshall**

**M-Lynx Series** 4:3 LCD Monitors

Professional-grade solutions for security, safety surveillance, CCTV or any other high quality commercial and industrial applications. Dynamic noise reduction and comb filter technology remove unwanted noise and minimize ghosting, complementing the M-Lynx's impressive contrast and brightness levels.



- 10" LCD Lynx Monitor (MAMLYNX10)..... 282.95**
- 15" LCD Lynx Monitor (MAMLYNX15)..... 370.99**
- 17" LCD Lynx Monitor (MAMLYNX17)..... 445.00**
- 10" Widescreen 16:9 LCD Monitor (MAMLYNX10W)..... 368.95**
- 15" LCD Lynx with Rack (MAMLYNX15RM)..... 439.50**
- 17" LCD Lynx with Rack (MAMLYNX17RM)..... 475.00**
- 19" LCD Lynx with Rack (MAMLYNX19RM)..... 567.78**

**Panasonic**

**BT-LH1710 • BT-LH1760**

17" HD/SD LCD Production Monitors

- AC/DC powered, the BT-LH1710 features built-in waveform and vectorscope, embedded audio support, pixel-to-pixel display, cross hatch overlay, audio level meters, time code and CC displays.
- Two HD-SDI/SDI auto-switching inputs/switched output, and DVI-D input/output.
- BT-LH1760 steps up with 120Hz double-speed drive, twice that of the BT-LH1710



- #PABTLH1710 ..... **2389.95** #PABTLH1760 ..... **3999.95**
- BT-LH1850** 18.5" HD/SD LCD Monitor (PABTLH1850)..... **2139.95**
- BT-LH2170** 21.5" LCD Studio Monitor (PABTLH2170P)..... **3250.00**

**BT-LH2550**

26" Widescreen HD/SD LCD Video Monitor

26" widescreen monitor designed for broadcast and studio applications, the monitor features 1920 x 1200 resolution, 1:1 Pixel-to-Pixel Mapping, and compensates for RGB accuracy in 256 discrete steps. Two SDI inputs with automatic switching between HD and SD, one SDI output, a component input with RGB switching, Y/C and composite video. (PABTLH2550)..... **3449.95**

- TH-32LRU50** 32" Hospitality LCD TV (PATH32LRU50)..... **461.99**
- TH-42LRU5** 42" Hospitality LCD TV (PATH42LRU5)..... **678.99**
- TH-42LRU50** 42" Hospitality LCD TV (PATH42LRU50)..... **769.95**

**MONITOR ACCESSORIES**

- Yoke Mount for BT-LH1700W/BT-LH1710 (OPYMLH1700)..... **449.00**
- Monitor Hood for Panasonic BT-LH910 (POMOHLH910L)..... **138.01**
- Rack-Mount Ears for BT-LH1700W (PABTMA1710G)..... **209.95**
- Plexiglas Protection Panel for BT-LH1700 (PABTYU17PLX)..... **89.95**
- Stereo Speaker Kit for 42" Plasma (PATYSP42P8WK)..... **219.95**
- Stereo Speaker Kit for 50" Plasma (PATYSP50P8WK)..... **299.00**
- BT-YUC1700 Hard Case (PABTYUC1700W)..... **345.95**
- BT-YUC1700 Hard Case (PABTYUC1700)..... **249.95**
- TY-FB10HMD Dual HDMI Board (PATYFB10HMD)..... **168.02**
- TY-FB11DD DVI Plug-In Board (PATYFB11DD)..... **140.75**
- TY-FB9HD HD-SDI Board (BNC) (PATYFB9HD)..... **1202.52**
- G-MONITOR2-G019 for 19" Flat Screen (GAGM2G019)..... **99.99**
- G-MONITOR2-G022 for 22" Flat Screen (GAGM2G022)..... **Log-on**

**TTE VISION**

**LCD-1560HD** 15.6" HD LCD Monitor

Housed in a durable black metal casing, features anti-glare surface, blue only mode, RS-232 port, and quick 8ms response. Includes IR remote, built-in removable desk stand, and a built-in interface for wall mounting. Compatible with composite NTSC/PAL (auto switching), S-Video, analog RGB, component, and HDMI input signals.



- #TOLCD1560HD..... **794.70**
- 15.6" LCD-1560HDR Rack Monitor Kit (TOLCD1560HDR)..... **614.00**
- LCD-400X4** Four 4" LCD Monitors (TOLCD400X4)..... **1211.40**

**CHIEF**

FSP-4100B Pole Mount for small displays (CHF-SP4100B)..... **157.00**



- FSR-4100 Fixed Wall Mount (CHFSR4100)..... **36.95**
- FSRV Fixed Wall Mount (CHFSRV)..... **36.95**
- FTR4100 Tilting Flat Panel Wall Mount (CHFTR4100)..... **51.67**
- FTRV Tilting Flat Panel Wall Mount (CHFTRV)..... **35.99**
- FWD-110B Dual Swing Arm Wall Mount (CHFWD110B)..... **77.54**
- Flat Panel Single Ceiling Mount (CHJHSUB)..... **76.84**
- Dual Swing Arm Wall Mount (CHJWDUB)..... **158.90**
- KCG110B Dual Arm Desk Mount (CHKCG110B)..... **154.95**
- KPD110B Dual Arm Pole Mount (CHKPD110B)..... **148.65**
- Flat Panel Pivot/Tilt Pole Mount (CHKPP110B)..... **69.95**
- Dual Horizontal Monitor Grommet Mount (CHKTG220B)..... **153.95**
- Dual Widescreen Monitor Table Stand (CHKTP225B)..... **164.50**
- Triple Swing Arm Wall Mount (CHKWB110B)..... **175.91**
- Dual Swing Arm Wall Mount (CHKWG110B)..... **161.95**
- Universal Flat Panel Fixed Wall Mount (CHLSAU)..... **102.50**
- LSMU Micro-Adjustable Fixed Wall Mount (CHLSMU)..... **126.99**
- Fusion Pull-Out Wall Mount (Large) (CHLSMVU)..... **285.65**
- Thinstall Universal Fixed Wall Mount (CHLSTU)..... **99.95**
- TS118SU Thinstall Dual Swing Arm Mount (CHTS118SU)..... **84.77**
- TS218SU Thinstall Dual Swing Arm Mount (CHTS218SU)..... **134.26**
- TS525TU Thinstall Swing Arm Wall Mount (CHTS525TU)..... **302.40**
- Flat Panel Portrait Tilt Wall Mount (37-63") (CHLTAPU)..... **161.45**
- Universal Flat Panel Tilt Wall Mount (37-63") (CHLTAU)..... **127.50**
- Micro-Adjustable Tilt Wall Mount (37-63") (CHLTMU)..... **177.95**
- MCSU Mid Size Ceiling Mount (CHMCSU)..... **149.99**
- MCSV Universal Flat Panel Ceiling Mount (CHMCSV)..... **122.40**
- Micro-Adjustable Fixed Wall Mount (CHMSMU)..... **87.88**
- Fusion Portrait Tilt Wall Mount (CHMTAPU)..... **99.99**
- Fusion Tilt Wall Mount (26-47") (CHMTAU)..... **79.96**
- Micro-Adjustable Tilt Wall Mount (CHMTMU)..... **109.95**
- Thinstall/Tilt Wall Mount (26-47") (CHMTTU)..... **114.43**
- PCS-U Flat Panel Ceiling Mount (CHPCSU)..... **205.45**
- Large Flat Panel Swing Arm Wall Mount (CHPDRUB)..... **517.96**
- RLF2 FIT Low-Profile Hinge Mount (CHRLF2)..... **59.95**
- RLT2 Low-Profile Tilt Mount (CHRLT2)..... **74.95**
- RMF2 Fit Series Low-Profile Hinge Mount (CHRMF2)..... **49.95**
- RMT2 Low-Profile Tilt Mount (26-42") (CHRMT2)..... **59.95**
- TPMU Universal Flat Panel Tilting Pole Mount (CHTPMU)..... **187.95**
- Universal Micro-Adjustable Fixed Wall (CHXSMU)..... **159.93**
- Universal Micro-Adjustable Tilt Wall Mount (CHXTMU)..... **209.95**
- K1 Series Desk Clamp Mount (CHK1D100B)..... **143.00**
- KONTOUR Dual Arm Wall Mount (CHK2W100B)..... **115.85**
- KCY220 Height-Adjustable Dual Arm (CHKCY220B)..... **276.55**
- MF1-UB Flat Panel Floor Stand (CHMF1UB)..... **516.95**
- PF1-UB Flat Panel Display Floor Stand (CHPF1UB)..... **564.95**
- Heavy-Duty Custom Wall Mount (CHPSMH2840)..... **459.95**
- TPM-2000 Flat Panel Tilting Pole Mount (CHTPM2000)..... **183.20**
- PXRU Automated Swing Arm Wall Mount (CHPXRUB)..... **1979.50**

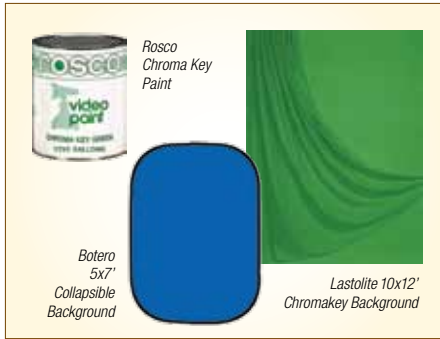

**CHROMA KEY EQUIPMENT**

**Backdrop-Alley Muslin Backgrounds**

- 8 x 10' - Chroma-Key Green (BABGSM810CG) ..... **59.95**
- 8 x 10' - Chroma-Key Blue (BABGSM810CB) ..... **59.95**
- 10 x 12' - Chroma-Key Green (BABGSM1012CG) ..... **69.95**
- 10 x 12' - Chroma-Key Blue (BABGSM1012CB) ..... **69.95**
- 10 x 24' - Chroma-Key Green (BABGSM1024CG) ..... **103.50**
- 10 x 24' - Chroma-Key Blue (BABGSM1024CB) ..... **103.50**

**Botero Collapsible Backgrounds**

- 5 x 7' Chroma-Key Blue (BOBC57027), Green (BOBC57026) .. **63.95**
- 5 x 7' Reversible - Chroma-Key Blue/Green (BOBC57036) .. **79.95**
- 8 x 16' - Chroma-Key Blue (BOBSC816027) ..... **129.95**
- 8 x 16' - Chroma-Key Green (BOBSC816026) ..... **129.95**
- Muslin 10 x 12' - Chroma-Key Blue (BOBM1012027) ..... **82.95**
- Muslin 10 x 12' - Chroma-Key Green (BOBM1012026) ..... **82.95**
- Muslin 10 x 24' - Chroma-Key Green (BOBM1024026) ..... **149.95**
- Muslin 10 x 24' - Chroma-Key Blue (BOBM1024027) ..... **149.95**

**Cool-Lux**

- 57 x 77" Blue/Green Screen (COCH57) ..... **57.95**

**General Brand**

- Chromakey Cloth Gaffer's Tape 2" x 20 Yards in Blue (GB-PCT220BL) or Green (GBPCT220GR) ..... **45.95**

**Impact**

- 10 x 12' Chroma Blue Background (IMBGC1012) ..... **58.95**
- 10 x 12' Chroma Green Background (IMBGC1012) ..... **58.95**
- 10 x 24' Chroma Green Background (IMBGC1024) ..... **114.95**
- 10 x 24' Blue Chroma Background (IMBGC1024) ..... **114.95**

**Matthews**

- 6 x 6' Solid Digital Green Screen (MADS66GR) ..... **142.50**
- 6 x 6' Reversible Blue/Green MATT Screen (MACSBG66) ..... **218.95**
- 6 x 6' Blue/Green Digital Screen (MADS66BG) ..... **226.95**
- 8 x 8' Solid Digital White Screen (MADS88W) ..... **172.50**
- 8 x 8' Solid Digital Green Screen (MADS88GR) ..... **237.50**
- 8 x 8' Blue/Green Digital Screen (MADS88BG) ..... **307.95**
- 8 x 8' Reversible Blue/Green MATT Screen (MACSBG88) ..... **312.00**
- 12 x 12' Solid Digital White Screen (MADS1212W) ..... **254.95**
- 12 x 12' Solid Digital Green Screen (MADS1212GR) ..... **394.95**
- 12 x 12' Blue/Green Digital Screen (MADS1212BG) ..... **527.50**
- 12 x 12' Rev. Blue/Green MATT Screen (MACSBG1212) ..... **489.00**
- 20 x 20' Solid Digital White Screen (MADS2020W) ..... **638.95**
- 20 x 20' Solid Digital Green Screen (MADS2020GR) ..... **794.95**
- 20x20' Rev. Blue/Green MATT Screen (MACSBG2020) ..... **799.50**
- 20 x 20' Blue/Green Digital Screen (MADS2020) ..... **899.00**

**Reflecmidia**

- BaseMatte Tile (REBM214) ..... **1260.00**
- Chromatte Medium Green Light Ring Kit (RECM127MGRK) **3108.50**

**Rosco**

- Chroma Key Paint 1-Gallon in Blue (R05710G) ..... **69.95**
- Paint, Green - 1 Gallon (R05711G) ..... **69.95**
- Paint, Green - 5 Gallons (R057115G) ..... **325.95**

**Photoflex**

- 5x7' Reversible Blue/Green (PHFDCKBLGR) ..... **164.95**

**Westcott**

- Digital Green Screen Photo Kit (WEDGSPK) ..... **69.90**

**BNC TO BNC CABLES**

**Canare**

BNC to BNC (SDI) Cable

- 6' (CACSDI6) ..... **18.99**    50' (CACSDI50) ..... **59.99**
- 10' (CACSDI10) ..... **21.99**    75' (CACSDI75) ..... **69.99**
- 15' (CACSDI15) ..... **24.95**    100' (CACSDI100) ..... **79.99**
- 25' (CACSDI25) ..... **32.99**    150' (CACSDI150) ..... **109.95**

Double Shielded BNC Cable

- 3' (CADSBB3) ..... **14.95**    75' (CADSBB75) ..... **99.95**
- 10' (CADSBB10) ..... **34.95**    100' (CADSBB100) ..... **139.95**
- 25' (CADSBB25) ..... **49.95**    200' (CADSBB200) ..... **239.95**
- 50' (CADSBB50) ..... **74.95**    300' (CADSBB300) ..... **299.95**

HD-SDI 22 AWG RG59 Cable (BNC)

- 1' (CA35HSVB01) ..... **17.49**    20' (CA35HSVB20) ..... **29.99**
- 2' (CA35HSVB02) ..... **18.49**    25' (CA35HSVB25) ..... **37.99**
- 3' (CA35HSVB03) ..... **19.99**    35' (CA35HSVB35) ..... **39.95**
- 6' (CA35HSVB06) ..... **21.99**    50' (CA35HSVB50) ..... **59.95**
- 10' (CA35HSVB10) ..... **24.99**    75' (CA35HSVB75) ..... **84.95**
- 15' (CA35HSVB15) ..... **27.99**    100' (CA35HSVB100) ..... **99.95**

HD-SDI 18 AWG RG6 Cable (BNC) in Black

- 0.5' (CA56HSVB00.5) ..... **14.99**    20' (CA56HSVB20) ..... **42.95**
- 1' (CA56HSVB01) ..... **20.49**    25' (CA56HSVB25) ..... **49.95**
- 2' (CA56HSVB02) ..... **20.99**    35' (CA56HSVB35) ..... **69.95**
- 3' (CA56HSVB03) ..... **21.99**    50' (CA56HSVB50) ..... **79.95**
- 6' (CA56HSVB06) ..... **22.49**    100' (CA56HSVB100) ..... **149.95**
- 10' (CA56HSVB10) ..... **28.99**    150' (CA56HSVB150) ..... **219.95**
- 15' (CA56HSVB15) ..... **34.95**    200' (CA56HSVB200) ..... **299.95**

HD-SDI 18 AWG RG6 Cable (BNC) in Blue

- 1' (CA56HSVB01BL) ..... **20.49**    20' (CA56HSVB20BL) ..... **48.95**
- 2' (CA56HSVB02BL) ..... **20.99**    25' (CA56HSVB25BL) ..... **54.95**
- 3' (CA56HSVB03BL) ..... **21.99**    50' (CA56HSVB50BL) ..... **84.95**
- 6' (CA56HSVB06BL) ..... **24.49**    100' (CA56HSVB100BL) ..... **129.95**
- 10' (CA56HSVB10BL) ..... **32.99**    150' (CA56HSVB150BL) ..... **219.95**
- 15' (CA56HSVB15BL) ..... **39.95**    200' (CA56HSVB200BL) ..... **299.95**

HD-SDI 18 AWG RG6 Cable (BNC) in Red

- 1' (CA56HSVB01RD) ..... **20.99**    25' (CA56HSVB25RD) ..... **54.95**
- 3' (CA56HSVB03RD) ..... **21.99**    50' (CA56HSVB50RD) ..... **64.00**
- 6' (CA56HSVB06RD) ..... **24.49**    100' (CA56HSVB100RD) ..... **149.95**
- 10' (CA56HSVB10RD) ..... **27.00**    150' (CA56HSVB150RD) ..... **219.95**
- 20' (CA56HSVB20RD) ..... **39.95**    200' (CA56HSVB200RD) ..... **299.95**

HD-SDI 18 AWG RG6 Cable (BNC) in Green

- 1' (CA56HSVB01GN) ..... **20.99**    20' (CA56HSVB20GR) ..... **48.95**
- 3' (CA56HSVB03GN) ..... **21.99**    100' (CA56HSVB100G) ..... **149.95**
- 6' (CA56HSVB06GN) ..... **24.49**    150' (CA56HSVB150G) ..... **219.95**
- 10' (CA56HSVB10GR) ..... **27.00**    200' (CA56HSVB200G) ..... **299.95**

**Comprehensive**

BNC Male to BNC Male Cable

- 3' (COCBB3) ..... **8.79**    25' (COCBB25) ..... **12.99**
- 6' (COCBB6) ..... **7.95**    50' (COCBB50) ..... **19.99**
- 15' (COCBB15) ..... **12.79**    100' (COCBB100) ..... **35.99**

3-BNC Male to 3-BNC Male Cable -

- 6' (COC3B3B6) ..... **23.61**    25' (COC3B3B25) ..... **47.99**
- 10' (COC3B3B10) ..... **35.19**    50' (COC3B3B50) ..... **63.99**
- 100' (COC3B3B100) ..... **99.99**

5-BNC Male to 5-BNC Male Cable

- 3' (COC5B5B3) ..... **27.99**    25' (COC5B5B25) ..... **47.99**
- 6' (COC5B5B6) ..... **30.32**    50' (COC5B5B50) ..... **63.99**
- 10' (COC5B5B10) ..... **35.99**    100' (COC5B5B100) ..... **119.99**

**Datavideo**

- 50 ft. Male to Male BNC Cable (DACASDI50) ..... **67.00**
- 100 ft. Male to Male BNC Cable (DACASDI100) ..... **125.00**
- 150 ft. Male to Male BNC Cable (DACASDI150) ..... **172.00**

**Hosa Technology**

- BNC Male to BNC Male Cable - 15' (HOBB15) ..... **12.79**

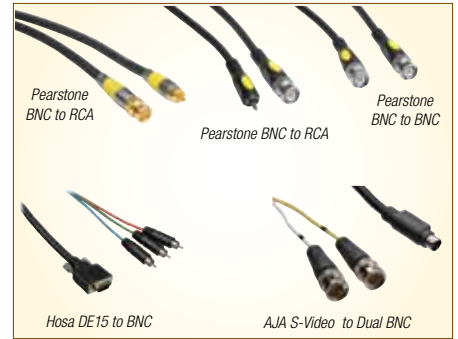

**Pearstone**

BNC to BNC Video Cable

- 1.5' (PECCBB1.5) ..... **7.50**    15' (PECCBB15) ..... **11.95**
- 3' (PECCBB3) ..... **7.95**    25' (PECCBB25) ..... **12.95**
- 6' (PECCBB6) ..... **8.95**    50' (PECCBB50) ..... **18.95**
- 10' (PECCBB10) ..... **10.95**    100' (PECCBB100) ..... **27.95**

Premium BNC to BNC Video Cable

- 1.5' (PEPCBB1.5) ..... **10.95**    15' (PEPCBB15) ..... **19.95**
- 3' (PEPCBB3) ..... **9.95**    25' (PEPCBB25) ..... **24.95**
- 6' (PEPCBB6) ..... **13.95**    50' (PEPCBB50) ..... **36.95**
- 10' (PEPCBB10) ..... **17.95**    100' (PEPCBB100) ..... **59.95**

BNC Male to RCA Male Video Cable

- 1.5' (PECBR1.5) ..... **5.95**    15' (PECBR15) ..... **11.50**
- 3' (PECBR3) ..... **6.50**    25' (PECBR25) ..... **13.50**
- 6' (PECBR6) ..... **7.95**    50' (PECBR50) ..... **19.95**
- 10' (PECBR10) ..... **9.95**    100' (PECBR100) ..... **39.95**

**Pearstone Gold Series**

Premium BNC Male to RCA Male Video Cable

- 1.5' (PEPCBR1.5) ..... **7.50**    15' (PEPCBR15) ..... **15.95**
- 3' (PEPCBR3) ..... **8.95**    25' (PEPCBR25) ..... **19.95**
- 6' (PEPCBR6) ..... **10.95**    50' (PEPCBR50) ..... **27.95**
- 10' (PEPCBR10) ..... **12.95**    100' (PEPCBR100) ..... **37.95**

**DB15-to-Bnc CABLES**

**Comprehensive**

- VGA HD15 to 3x RCA Component Cable - 3' (COCVGAM3R3) ..... **19.99**
- VGA HD15 to 3x RCA Component Cable - 10' (COCVGAM3R10) ..... **39.99**
- VGA HD15 to 3x RCA Component Cable - 25' (COCVGAM3R25) ..... **47.99**

**Y-CABLES**

**Comprehensive**

- HR Series S-Video 4-pin Male to 2x BNC Male (COYCSV4M2B10) ..... **19.99**
- HR Series S-Video 4-pin Male to 2x BNC Male (COYCSV4M2B6) ..... **19.99**

**Hosa Technology**

- S-Video to 2x BNC Female Video Cable - 10' (HOYCSV2BF10) ..... **8.99**
- S-Video to 2x BNC Male Video Cable - 6' (HOYCSV2BM6) ..... **7.99**
- S-Video to 2x RCA Male Video Cable - 6' (HOYCSV2RM6) ..... **6.99**
- VGA Male to 2x VGA Female Video Y-Cable - 6' (HOYCV2M2VF) ..... **12.99**

**VIDEO CONNECTORS**

**Comprehensive**

- BNC Crimp Connector Kit (COBCK2) ..... **125.00**
- 75 Ohm Male 3 piece BNC Connector (COCBQ) ..... **2.50**
- BNC Terminator (COCBT) ..... **2.63**
- BNC EZ Connector (COCEZB59) ..... **3.19**
- BNC EZ Connector (COCEZB6) ..... **3.19**
- DA-15 Connector, Male (CODB15M) ..... **2.84**
- FS6 EZ F-Connector (COCEZF6) ..... **0.72**
- RG6BNCHR BNC EZ Connector (COCEZB6) ..... **3.83**

**Neutrik**

- NF2D-B-2 Female RCA Socket, Red (NENF2DBR) ..... **3.95**
- NF2D-B-9 Female RCA Socket, White (NENF2DBW) ..... **3.99**
- 75ohm BNC Bulkhead Connector (NENBB75DSI) ..... **6.98**

800-947-1186 | 212-444-6686

VIDEO ADAPTERS

**Atlona**

DVI-D Female To HDMI Male Adapter (AT14040).....	19.99
HDMI Female To DVI-D Male Adapter (AT14041).....	19.99
HDMI Female Coupler (AT14042).....	23.74
HDMI Screw-Lock Male To DVI Female (AT14048).....	19.99

**Comprehensive**

BNC to BNC Adapter (COABFBF).....	3.43
Female BNC to Female Type-F Adapter (COABFFF).....	1.91
Female BNC to Male Type-F Adapter (COABFFM).....	1.91
Female BNC to Male RCA Adapter (COABFRM).....	2.39
Male BNC to Fem. BNC Angled Adapter (COABMBFRA).....	5.03
Male BNC to Male BNC Adapter (COABMBM).....	3.59
Male BNC to Female RCA Adapter (COABMRFF).....	1.99
Male BNC to Male RCA Adapter (COABMRM).....	1.99
Female Type-F to Female Type-F Adapter (COAFFFF).....	0.79
Male RCA to Type-F Coaxial Female Adapter (COARFFF).....	1.59
Female S-Video to Female S-Video Adapter (COASV4F4F).....	4.79
Female VGA to Female VGA Adapter (COAVFVF).....	8.79
Female DVI-A to Male HD-15 (CODVIAJHD15P).....	7.99
Female HDMI to Male DVI-D (COHDMJDVIDP).....	6.39
Male HDMI to Female DVI-D (COHDMIDVIDJ).....	6.39
Male BNC to Two BNC Female T-Adapter (COTABM2F).....	4.15
Premium Video Adapter Kit (COVDAPT).....	63.96
Male BNC to Male Type-F Adapter (COABMFM).....	1.99
F-Jack to BNC adapter (COABMFF).....	2.99
BNC to BNC Adapter f/Chassis Mount (COABFBFCM).....	3.99
3 BNC-F to - T Adapter (COTAB3F).....	4.15
DVI-D Jack to Jack Gender Changer (CODVIDJ).....	15.99
"F" Jack to Plug Right Angle Screw-On (COFJPLS).....	1.59
HDMI Female to Male Adapter With 360° (COHDFM360).....	7.49

**Gefen**

DVI-D Female to HDMI Female Adapter (GEAHD01).....	Log-on
VGA 15-pin (HD-15) Coupler - Female to Male (GEVMAF).....	Log-on

**Hosa Technology**

BNC to BNC Adapter (HOABFBF).....	1.99
BNC to RCA Adapter (HOABFRF).....	1.99
BNC to RCA Adapter (HOABFRM).....	1.95
BNC to RCA Adapter (HOABMRFF).....	4.15
Video BNC Male to RF Female Adapter (HOARBFM).....	2.50
RCA to S-Video Adapter (HOARFSVM).....	9.30
RCA to S-Video Adapter (HOARMSVF).....	4.49
S-Video to S-Video Adapter (HOASVS).....	4.99
Male S-Video to Fem. RCA (6") (HOVCSVMRF6).....	6.99
RCA to Type F Adapter (HOARFRM).....	1.30
RCA Male to RF Female Adapter (HOARMRF).....	1.20
RF Female to RF Female Adapter - 2 Pack (HOARFRF20).....	2.50

**Mace**

Female BNC to BNC Female Connector (MAFBNCFBNC).....	1.95
BNC Elbow Adapter (MABNCRIGHTAN).....	2.49
Male BNC to Female RCA Connector (MAMBNCFRCA).....	2.00
Male BNC to Male BNC Connector (MAMBNCMBNC).....	1.95
Male BNC to Female BNC Connector (MAMBNCFBNC).....	1.99
Female BNC to Male RCA Connector (MAFBNCMRCA).....	1.95

**Monster Cable**

HDMI to DVI Video Adapter MKII (MOVAHDMIDVI).....	17.97
DVI to HDMI Video Adapter MKII (MOVADVIHDM).....	20.14
90 Degree HDMI Adapter (MOAHDMI).....	13.99

**Pearstone**

HDMI Female to HDMI Female Coupler (PEHDAFSS).....	6.49
HDMI 90° Adapter - Horizontal to Vertical (PEHDASH).....	7.49
HDMI 90° Adapter - Vertical Flat Left (PEHDASL).....	6.49
HDMI 90° Adapter - Vertical Flat Right (PEHDASRV).....	6.99
HDMI Female to Mini HDMI Male Adapter (PEHDCCS).....	5.99

**Xtreme Cables**

90° HDMI Adapter (XTHDMA9B).....	7.99
HDMI Female to HDMI Female Adapter (XTHDMIFE).....	8.90
HDMI to Mini HDMI Adapter (XTHDMIABP).....	9.99
HDMI to Micro HDMI Adapter (XTHDMIMHDMIA).....	7.99

CABLE COVERS, TUNNELS & REELS

Belkin RJ-45 Crimp Tool (BEF4F198).....	11.95
K&M Velcro Cable Holder (3) - Black (KM21403).....	4.99
OP/TECH STRAPEEZ Cable Management Straps (OPSB0).....	5.95
Sanus ELM301 Cable Tunnel Kit (SAELM301W1).....	Call or Log-on
SKB SKB-VS1 Hook and Loop Fastener Shelf (SKVS1).....	Call or Log-on
TecNec VEL-90209 4 Sets of Velcro Strips (TEVEL90209).....	9.95
The Cable Organizer 1" Cable Cover White - 8' (CACZ110W).....	12.95
The Cable Organizer 1" Cable Cover Gray - 8' (CACZ110G).....	10.99

**Bluelounge**

Medium Cable Clips (4-Pack) (BLCCM).....	8.95
CableBox in Black (BLCB01BL) or White (BLCB01WH).....	26.95
CableDrop in Bright Colors (BLCDB) or Muted Colors (BLCDM).....	8.95
CableDrop in White (BLCDWH) or Black (BLCDBL).....	8.99
Small Cable Clips (6-Pack) (BLCCS).....	8.95

**CableWrap (10 Packs)**

1 x 6" in Black (RICW610B) or Rainbow (RICW610RB).....	17.95
1 x 9" in Black (RICW910B) or Rainbow (RICW910RB).....	22.95
1 x 14" in Black (RICW1410B) or Rainbow (RICW1410RB).....	26.95
1 x 21" in Black (RICW2110B).....	29.95
EconoWrap 3/4 x 7" Elastic Ties (Black, 20 Pk) (RIEW720B).....	15.95
Mini Cable Wraps in Black (RIQ35007BK) or White (RIQ35007W).....	4.95
Lite 1/2 x 6" Light-duty Strap (10 pk) Rainbow (RIRTL610RB).....	5.49
Lite 1/2 x 8" Light-duty Strap (10 pk) Black (RIRTL810B).....	6.87
Lite 1/2 x 8" Light-duty Strap (10 pk) Rainbow (RIRTL810RB).....	8.99
Lite 1/2 x 12" Light-duty Strap (10 pk) Black (RIRTL1210B).....	4.95
Lite 1/2 x 12" Light-duty Strap (10 pk) Rainbow (RIRTL1210RB).....	7.95
Lite 1/2 x 18" Light-duty Strap (10 pk) Black (RIRTL1810B).....	10.75
Lite 1 x 10" Light-duty Strap (10 pk) Black (RIRTL1010B).....	15.50
RipWrap Tape 1 x 30' (Black) (RIRW130B).....	5.19
RipWrap Tape 1/2" x 75' (Black) (RIRW75B).....	9.75
RipWrap Tape 1/2" x150' (Black) (RIRW150B).....	18.49
RipWrap Non Adhesive Tape (RIRW30B).....	6.18
U-20-040-FC Unitag 5/8 x 2.0" Cable ID (RIU2404C).....	9.29
V-L3-004-BK 1 x 3" "Hook and Loop" Fastener (RIHL34B).....	4.49
WrapStrap Plus 1/2 x 75' (Black) (RIWSP75B).....	13.15

**Delta 1**

Ripgrip Cable Wrap Pack of 2 (Black) (DECW24B).....	4.95
Ripgrip Cable Wrap (Pack of 2) (Red) (DECW24R).....	4.95
Ripgrip Ring Strap (Pack of 4) (DERGRS).....	11.95

**Dotz**

Cord Identifiers - Bright (DODCI101COB).....	3.99
Cord Identifiers - Pastel (DODCI101COPC).....	3.99
Reusable Cord Straps (5 Pack) (DODCS201AN5).....	4.49
Permanent Cord Straps (35 Pack) (DOPCS232MC35).....	4.99
72 x 0.75" Spiral Tube (DOSCT500B).....	8.99

**Kino Flo**

12" Touch Fastener Tie Wrap - 20 Pack in Green (KIVTW20G), White (KIVTW20W), Yellow (KIVTW20Y), Red (KIVTW20R), Orange (KIVTW20O), Blue (KIVTW20B) or Gray (KIVTW20GR).....	16.95
---	-------

**Hosa Technology**

Astro-Grop Hook & Loop Cable Organizer (HOAG5).....	8.79
LBL-466 - Peel & Stick Vinyl Cable Labels (60) (HOLBL466).....	11.90
WTI-294 Releasable Ties (White) (HOWT8RTB).....	3.50
WTI-172 8" Wire Ties (White) (HOWT8W).....	2.75
5 Piece Pack of 8" Hook & Loop Plain Black (HOWT1148).....	5.99
Hook and Loop Organizer 0.75 x 8", 20 pc. (HOWT1148G20).....	8.95
Hook and Loop Organizer 0.75 x 12", 5 pc. (HOWT1156G).....	3.95

**Porta Brace**

CB-810 9" Cable Binders (Set of 4) (POCB810).....	13.89
PS-6 6" Piggoin String (4) (POPS6).....	12.15
PS-6 12" Piggoin String (4) (POPS12).....	13.89



**Raxxess**

4" Cable Ties (Bag of 100) (RACT10004).....	9.95
8" Cable Ties (Bag of 100) (RACT10008).....	10.99
8" Reusable Cable Ties (Bag of 100) (RACT10008R).....	16.50
CBLD Cable Depot - holds 30 cables (RACBLD).....	12.50

**Rip-Tie**

CableCatch 1 x 2" (Black) (RICC25B).....	11.95
CableCatch 1 x 4" (Black) (RICC45B).....	13.50
Carabiner CableCarrier 1 x 6" (2-Pack) (RICCC62B).....	7.62
1 x 12" Cinch Strap (2-Pack) (RICS122B).....	5.95
1 x 18" Cinch Strap (2-Pack) (RICS182B).....	7.19
1 x 10" CinchStrap-EG (10-Pack) (RICSEG1010B).....	31.25
1 x 3" Cable Wrap (Black, 10-Pack) (RICW310B).....	18.50
RipWrap Tape 1.0" x 75' (Black) (RIRW175B).....	19.95

**Safcord**

4" x 6" in Navy (SAS46NB), Yellow (SAS46Y) or Gray (SAS46G).....	27.00
4" x 30" in Navy Blue (SAS430NB) or Gray (SAS430G).....	117.00
Cord and Cable Protector, Hooks to carpet, 3" x 6' (SAS36G).....	21.00
Cord and Cable Protector, Hooks to carpet, 4" x 6' (SAS46B).....	27.00
Cord and Cable Protector, Hooks to carpet, 4" x 6' (SAS46T).....	27.00
Cord and Cable Protector, Hooks to carpet, 4" x 30' (SAS430B).....	117.00
Cord and Cable Protector, Hooks to carpet, 4" x 30' (SAS430Y).....	117.00

**Pearstone**

1 x 6" Touch Fastener Cable Straps (PECS100610B).....	9.99
1 x 6" Touch Fastener Cable Straps (PECS100610M).....	16.99
1 x 9" Touch Fastener Cable Straps (PECS100910B).....	15.99
1 x 9" Touch Fastener Cable Straps (PECS100910M).....	19.99
1 x 12" Touch Fastener Cinch Strap (PECHS101202B).....	4.99
1 x 18" Touch Fastener Cinch Strap (PECHS101802B).....	6.49
1 x 14" Touch Fastener Cable Straps (PECS101410B).....	19.95
1 x 14" Touch Fastener Cable Straps (PECS101410M).....	24.95
4" Cable Ties - Black (100-Pack) (PECT04100B).....	1.99
4" Cable Ties - Clear (100-Pack) (PECT04100C).....	1.99
8" Cable Ties - Black (100-Pack) (PECT08100B).....	1.99
8" Cable Ties - Clear (100-Pack) (PECT08100C).....	1.99
8" Reusable Cable Ties - Black (20-Pack) (PECTR0820B).....	2.49
8" Reusable Cable Ties - Clear (20-Pack) (PECTR0820C).....	2.49
8" Reusable Cable Ties - Black (100-Pc.) (PECTR08100B).....	4.50
8" Reusable Cable Ties - Clear (100-Pc.) (PECTR08100C).....	4.50
0.5 x 6" Touch Fastener Straps (PES050610B).....	5.99
0.5 x 6" Touch Fastener Straps (PES050610M).....	4.99
0.5 x 8" Touch Fastener Straps in Black (PES050810B), Blue (PES050810BL), Green (PES050810GN), Gray (PES050810GY), Red (PES050810R), White (PES050810W) or Yellow (PES050810Y).....	6.99
0.5 x 12" Touch Fastener Straps in Black (PES051210B), Blue (PES051210BL), Green (PES051210GN), Gray (PES051210GY), Red (PES051210R), White (PES051210W) or Yellow (PES051210Y).....	5.49
0.5 x 18" Touch Fastener Straps in Black (PES051810B).....	9.49
1 x 10" Touch Fastener Straps in Black (PES101010B).....	13.99

**Stage Ninja**

Cable Winder (STSCW125).....	12.99
------------------------------	-------

**Tether Tools**

Hook & Loop Cable Ties 8" - 10-Pack (TECT58).....	7.95
trapMoore (TESSMRST).....	18.95
erkStopper - 4 Pack (TEJS030).....	12.95

VIDEO TUTORIALS

DVD: How to Setup, Light and Shoot Great (VOILDVD).....	32.95
DVD: Set Up and Shoot Awesome Interviews (VOLEDDVD).....	59.99
DVD: Mastering the Sony PMW-EX1 & EX1R (VOEX1DVD).....	77.95
DVD: Mastering the Sony PMW-EX3 (VOEX3DVD).....	69.95

DVD: Mastering the Canon XF305 & XF300 (VOXF3DVD).....	64.95
DVD: Mastering the Sony NEX-FS100 (VOFS100DVD).....	69.95
DVD: Mastering the Sony PMW-F3 (VOF3DVD).....	109.95
DVD: Mastering Sony's PMW-150/160/200 (VOXD422DVD).....	65.00