

Convertible Camera
AW-E860N

Operating Instructions

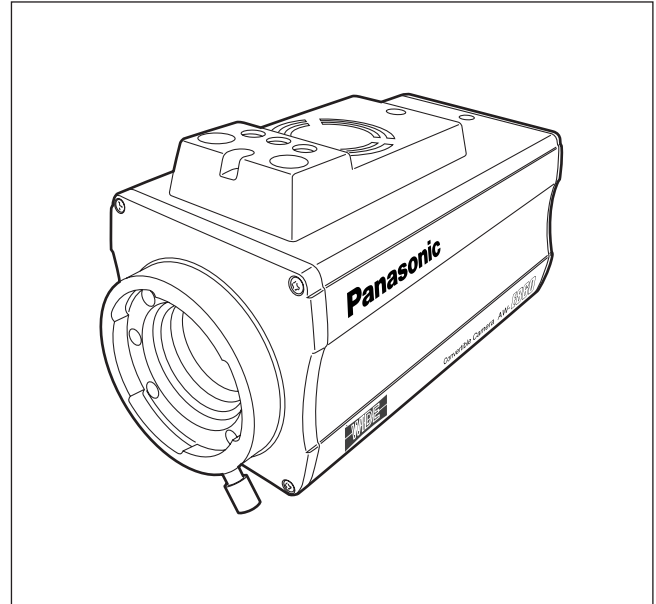

Panasonic®

Before attempting to connect, operate or adjust this product,
please read these instructions completely.



CAUTION
RISK OF ELECTRIC SHOCK
DO NOT OPEN



CAUTION: TO REDUCE THE RISK OF ELECTRIC SHOCK,
 DO NOT REMOVE COVER (OR BACK).
 NO USER SERVICEABLE PARTS INSIDE.
 REFER TO SERVICING TO QUALIFIED SERVICE PERSONNEL.



The lightning flash with arrowhead symbol, within an equilateral triangle, is intended to alert the user to the presence of uninsulated “dangerous voltage” within the product’s enclosure that may be of sufficient magnitude to constitute a risk of electric shock to persons.



The exclamation point within an equilateral triangle is intended to alert the user to the presence of important operating and maintenance (service) instructions in the literature accompanying the appliance.

WARNING:

TO REDUCE THE RISK OF FIRE OR SHOCK HAZARD, DO NOT EXPOSE THIS EQUIPMENT TO RAIN OR MOISTURE.

CAUTION:

TO REDUCE THE RISK OF FIRE OR SHOCK HAZARD AND ANNOYING INTERFERENCE, USE THE RECOMMENDED ACCESSORIES ONLY.

FCC Note:

This device complies with Part 15 of the FCC Rules. To assure continued compliance follow the attached installation instructions and do not make any unauthorized modifications.

This equipment has been tested and found to comply with the limits for a class A digital device, pursuant to Part 15 of the FCC Rules. These limits are designed to provide reasonable protection against harmful interference when the equipment is operated in a commercial environment. This equipment generates, uses, and can radiate radio frequency energy and, if not installed and used in accordance with the instruction manual, may cause harmful interference to radio communications. Operation of this equipment in a residential area is likely to cause harmful interference in which case the user will be required to correct the interference at his own expense.

For CANADA

This Class A digital apparatus complies with Canadian ICES-003.

Cet appareil numérique de la class A est conforme à la norme NMB-003 du Canada.

The serial number of this product may be found on the bottom of the unit.

IMPORTANT SAFETY INSTRUCTIONS

Read these operating instructions carefully before using the unit. Follow the safety instructions on the unit and the applicable safety instructions listed below. Keep these operating instructions handy for future reference.

- 1) Read these instructions.
- 2) Keep these instructions.
- 3) Heed all warnings.
- 4) Follow all instructions.
- 5) Do not use this apparatus near water.
- 6) Clean only with dry cloth.
- 7) Do not block any ventilation openings. Install in accordance with the manufacturer's instructions.
- 8) Do not install near any heat sources such as radiators, heat registers, stoves, or other apparatus (including amplifiers) that produce heat.
- 9) Do not defeat the safety purpose of the polarized or grounding-type plug. A polarized plug has two blades with one wider than the other. A grounding-type plug has two blades and a third grounding prong. The wide blade or the third prong are provided for your safety. If the provided plug does not fit into your outlet, consult an electrician for replacement of the obsolete outlet.
- 10) Protect the power cord from being walked on or pinched particularly at plugs, convenience receptacles, and the point where they exit from the apparatus.
- 11) Only use attachments/accessories specified by the manufacturer.
- 12) Use only with the cart, stand, tripod, bracket, or table specified by the manufacturer, or sold with the apparatus. When a cart is used, use caution when moving the cart/apparatus combination to avoid injury from tip-over. 
- 13) Unplug this apparatus during lightning storms or when unused for long periods of time.
- 14) Refer all servicing to qualified service personnel. Servicing is required when the apparatus has been damaged in any way, such as power-supply cord or plug is damaged, liquid has been spilled or objects have fallen into the apparatus, the apparatus has been exposed to rain or moisture, does not operate normally, or has been dropped.

CONTENTS

Preface	5
Features	6
Special notes on operation	7
Precautions	8
Major operating controls and their functions	10
Mounting	14
Flange back adjustment (For zoom lens)	16
Iris gain control in a lens	17
Connections	18
Adjustment	23
Use mode setting	29
Menu item setting	31
Setting and changing the optional cards	52
Setting to initial set	53
Appearance	57
Specifications	58
Standard accessories	60

Preface

- The Panasonic AW-E860N is a digital signal processing color video camera that incorporates three 2/3" wide CCDs. A digital video signal processing system is packed in a compact, lightweight body while assuring high picture quality, high reliability and high performance.
 - System setup and adjustments can be easily performed by following the setup menu.
 - Connection to peripheral devices, such as a RCU, a RCB and a lens and the camera pan/tilt unit enables a wide variation of system configurations.
 - Option cards may also be installed.
- ※ The following cards are not available for the AW-E860;
- AW-PB301 Component studio card:
Use AW-PB305.
 - AW-PB302 RGB card:
The camera unit contains this function.
 - AW-PB303 High-sensitivity card
 - AW-PB304 SDI card:
Use AW-PB504.
 - AW-PB306 Studio SDI card:
Use AW-PB506.
 - AW-PB307 SVGA card
 - AW-PB309 WEB card
 - AW-PB310 IEEE 1394 card

Note

In order to protect the environment when the convertible camera is to be discarded at the end of its service life, ask a specialized contractor to dispose of it properly.

Features

1. Digital video signal processing for high quality, high reliability, high performance, lightweight and compact size.
2. Resolution: 850 lines (HIGH BAND DTL: ON), S/N ratio: 65 dB (DNR ON)
3. Minimum illumination: 0.4 lx (F1.7, Night eye H mode)
4. SET UP menu for system check and readjustments.
5. Built-in automatic controls, including ATW, ELC, and AGC.
6. CCD readout is switchable between field and frame modes. Vertical resolution can be stepped up in frame mode and it is effective for shooting still objects.
7. The built-in synchronized scanning system reduces noise in computer graphics.
8. Various correction circuits permit video reproduction with high fidelity.
9. Chroma detail correction enables clear shots of dark color objects.
10. A dark detail circuit provides natural edge correction to any object in a dark scene.
11. The 12-axis digital color matrix enables users' to create images of their choice.
12. Four use modes for each of your specific applications can be selected.
13. SMPTE color bar is indicated on the monitor screen.
14. Remote control with a RCU, RCB or a Hybrid control panel.
15. Aspect ratio is 16:9 and 4:3 selectable.

Special notes on operation

- Turn power off before connecting or disconnecting cables.
- Connection or disconnection of any studio cable, RCB cable or other cable to any unit of equipment must be performed while power is off.
- While the camera is in automatic mode;
Shooting of bright objects in ELC operation mode may result in a smeared picture unique to the CCD.
The ATW function under fluorescent illumination can adversely change the white balance.
- There is a cooling fan inside. It is an expendable part, and must be replaced about every 30000 hours. (Whenever fan replacement is necessary, be sure to ask the store where you purchased the set.)

Precautions

DON'TS

- Do not attempt to disassemble the camera, remote control unit (RCU) or other units. In order to prevent electric shock, do not remove screws or covers. There are no user-serviceable parts inside.
- Do not abuse the camera. Avoid striking, shaking, etc. The camera contains sensitive components which could be damaged by improper handling or storage.
- Do not let the lens remain uncapped when the camera is not in use. If the lens is not installed, do not leave the lens mount hole uncovered.
- Do not touch the surface of the lens or prism.
- Do not use strong or abrasive detergents when cleaning the camera body.
- Do not aim the camera toward the sun, no matter whether it is turned on or not.
- Do not expose the camera or remote control unit (RCU) to rain or moisture, and do not try to operate the equipment in wet conditions. Do not operate the camera or RCU if it becomes wet.
- Do not operate the camera or remote control unit (RCU) outdoors during a lightning storm.
- Do not use the camera in an extreme environment where high temperatures or high humidity exist.
- Do not leave the camera and remote control unit (RCU) turned on when not in use. Do not unnecessarily turn the camera power on and off repeatedly. Do not block the ventilation slots.
- Do not cover the port otherwise block ventilation during operation. Internal heat buildup can cause a fire.

DOS

- Refer any servicing to qualified service personnel.
- Handle the camera with care.
- Protect the precision made lens by placing the lens cap over when the camera is not in use. If the lens is not installed, protect the surface of the prism by placing the body cap into the lens mount hole.
- Use a mild blower or lens cleaning tissue designed for coated lenses, to clean the surface of the lens or prism in the event that it should become dirty.
- Use a dry cloth to clean the camera if it is dirty. In case the dirt is hard to remove, use mild detergent and wipe gently.
- Use caution when operating the camera in the vicinity of spot lights or bright lights, as well as light reflecting objects and surfaces.
- Take immediate action if ever the camera or RCU should become wet. Turn the power off and have the unit checked by an authorized service facility.
- Follow normal safety precautions to avoid personal injury.
- Use the camera in an environment where the temperature is within 14°F to 113°F (–10°C to +45°C), and the relative humidity is within 30 % to 90 %.
- Always turn the power off when the camera is not going to be used. Operate the camera and RCU only when there is adequate ventilation.

Major operating controls and their functions

<Front view>

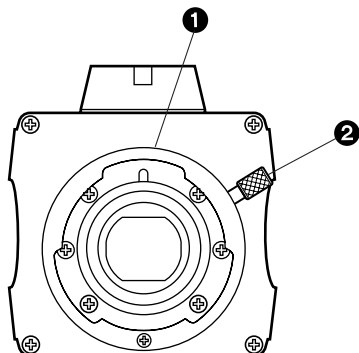

<Top view>

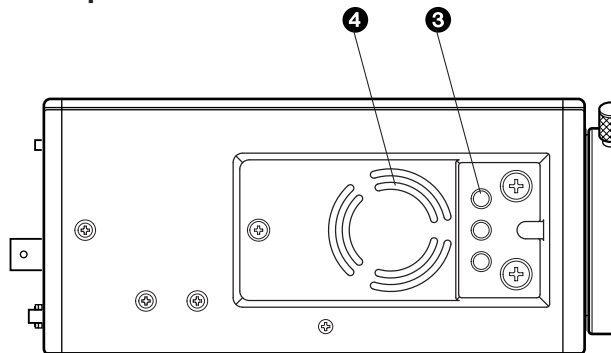

<Side view>

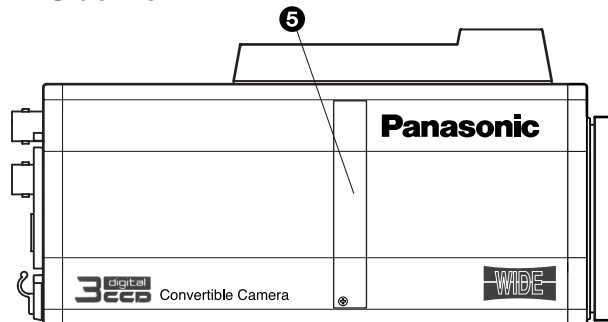

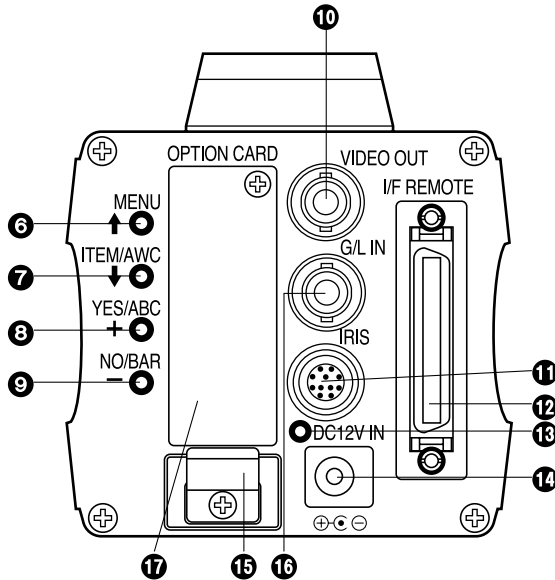

1 Lens mount

2/3" Standard bayonet type (B4 mount) lens or a microscope adapter can be mounted.

2 Lens fixing ring knob

Rotate the lens fixing ring knob counterclockwise and remove the lens mount cap. Mount the lens on the camera and rotate the lens fixing ring knob clockwise in order to fix the lens securely.

3 Mounting hole

A screw hole (1/4" - 20 UNC) for mounting the camera on a wall, ceiling with a mounting bracket or tripod.

4 Cooling fan

- Do not cover the port or otherwise block ventilation during operation. Internal heat buildup can cause a fire.
- The cooling fan has a service life of about 30000 hours. (at a room temperature of 25°C) Replace the fan that has come to the end of its service life. (If the fan is used at a room temperature of 35°C and above, replace it about 30% sooner.)

Whenever fan replacement is necessary, be sure to ask the store where you purchased the set.

5 Expansion slot

Remove the cover, and connect the expansion card box. For details, refer to the manual for expansion card box.

Major operating controls and their functions

6 MENU switch (MENU/ ↑)

A menu will appear on the monitor screen when this switch is pressed for about 5 seconds. This item can be selected by pressing the switch while the menu is on the screen.

7 ITEM/AWC switch (ITEM/AWC/ ↓)

The item just below can be selected by pressing this switch while the menu is on the screen. When the menu is not displayed or the camera is in shooting mode, the automatic white balance control can be set with this switch.

8 YES/ABC switch (YES/ABC/+)

The Sub Menu for each item of the Main Menu is displayed when this switch is pressed while the Main Menu is on the screen.

While the Sub Menu is displayed, any setting can be brought up to a higher value with this switch. When the menu is not displayed or the camera is in shooting mode, the automatic black balance control can be set with this switch.

9 NO/BAR switch (NO/BAR/–)

The item just below can be selected by pressing this switch while the Sub Menu is on the screen. While the Sub Menu is displayed any setting can be brought down to a lower value with this switch. When the menu is not displayed or the camera is in shooting mode, the color bar and the shooting conditions are alternately indicated by pressing the switch.

10 Video output connector (VIDEO OUT)

A composite video signal is provided at this connector.

11 Iris connector (IRIS)

Input terminal for lens with an iris control function.

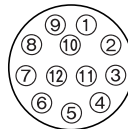

Pin No.	Signal	Pin No.	Signal
1	Return Control	7	Iris Follow
2	Not Used	8	Auto/Remote Control
3	GND	9	Not Used
4	Auto/Manual Control	10	Not Used
5	Iris Control	11	Not Used
6	Lens Power	12	Not Used

12 I/F Remote connector (I/F REMOTE)

Input terminal dedicated to control signals from the optional remote control box (RCB) (WV-CB700A, etc.) and the RCU (WV-RC700A, WV-RC550, etc.) and the camera pan/tilt unit (AW-PH400, etc.).

- WV-CB700A is connected through the optional RCB cable (AW-CA50T10/AW-CA50B10).
- WV-RC700A/WV-RC550 is connected through the optional RCU cable (AW-CA50A26).
- AW-PH400 is connected through the optional camera control cable (AW-CA50T8).

13 Power indicator

Red LED lamp lights to indicate that the specified DC power is supplied to the camera.

14 DC 12 V input connector (DC 12V IN)

12 V DC is supplied through the optional DC power supply cable (AW-CA4T1).

(Recommended AC adapter: AW-PS505)



Cautions

1. Connect this to a DC 12 V class 2 power supply only.
2. To prevent fire or shock, the UL listed wire VW-1, style 1007 should be used as for the cable for DC 12 V input connector.

15 Cable clamp

Clamp the DC power supply cable connected to the DC 12 V input connector to prevent it from slipping out.

16 G/L input connector (G/L IN)

Signals synchronized with the reference signal are to be supplied to this connector when the camera is to be synchronized with the reference signal BB.

17 Optional card slot

Slot for inserting an optional card. For details, refer to the manual for optional cards.

Mounting

- Lenses of any make can be mounted on the camera as long as they are equipped with a 2/3" standard bayonet.
- Use the lens extension cable AW-CA12T12A (6"/15 cm) if your lens cable is too short.

1. Lens mounting

Rotate the lens fixing ring knob counterclockwise and remove the lens mount cap. Mount the lens on the camera and rotate the lens fixing ring knob clockwise in order to fix the lens securely. Connect the camera cable to the IRIS connector on the back panel of the camera.

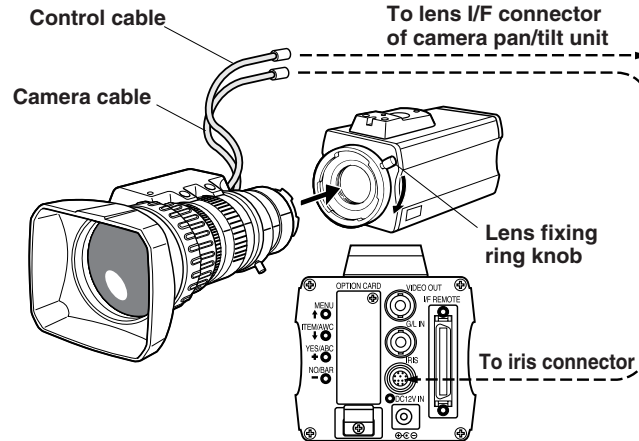

2. Camera mounting

1. To mount a camera on a pan/tilt head or a mounting bracket or the like, attach the mounting adapter (supplied) to the bottom of the camera in case of bottom mounting.

When changing the camera mounting adapter, use a screwdriver or similar tool to tighten the screws firmly.

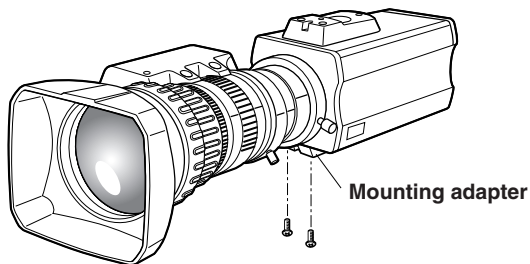

2. Fix the camera mounting base, pan/tilt unit, and tripod securely in the screw hole (1/4"-20UNC) of the camera or the mounting adapter.
3. If the camera cannot be securely fixed, mount the camera on a mounting bracket or the like with the supplied rubber sheet between the camera and it.
4. To mount the camera on the pan/tilt head, use a driver in order to fix it securely.

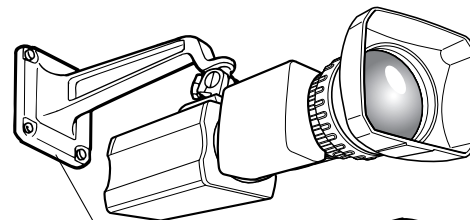

Camera mounting bracket (WV-831)

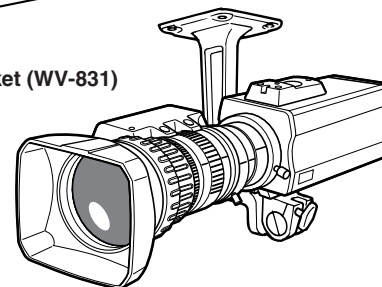

■ Preventing the camera from falling or coming off

- When attaching a camera to the pan/tilt head (AW-PH400, etc.), follow the directions in the Operating Instructions to fix the camera firmly in position. In addition, link the camera to the pan/tilt head using the safety chain and the mounting screws to help ensure the camera does not fall.
- When attaching the camera on any mounting or other pan/tilt head, check that the mounting can safely bear the total weight of the camera, lens, connection cables, etc., fix the camera firmly in position using the prescribed tool, and take appropriate measures to prevent the camera from falling.

Flange back adjustment (For zoom lens)

1. Fully open the iris by shooting a dark object. (Iris selection switch should be set to M.)
2. Loosen the flange back lock knob.
3. Aim the camera at any object over 2 meters away from the camera.
4. Set the lens to its TELE end first and adjust its focus with the focus ring.
5. Set the lens to its widest angle next and adjust its focus with the flange back adjust ring.
6. Adjust the focus ring and the flange back adjust ring alternately for the best focus within the zooming range. Tighten the flange back lock knob upon completion of focusing.
7. Turn the iris selection switch to Position A.

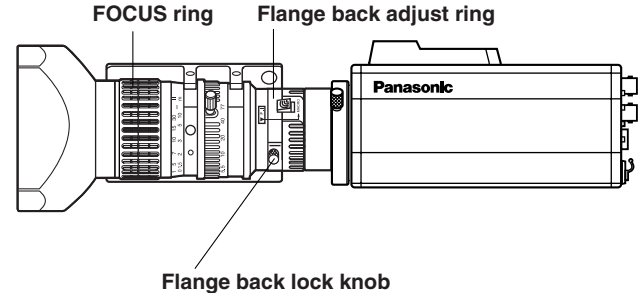

Iris gain control in a lens

An iris gain control hole is usually provided in the front of the lens. Adjustment of the iris gain, with a screwdriver through the hole may be done as follows. (Shape and location of the hole may vary depending on the type of lens.)

1. Turn the iris selection switch to Position A (AUTO).
2. Rotate the iris gain control to the maximum gain, but in a range where no hunting or oscillating of the iris ring develops.

Iris gain control (G, S)

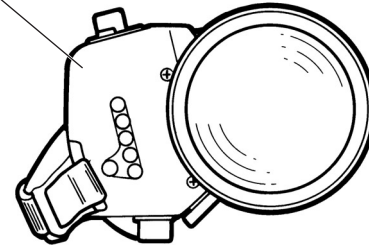

Automatic iris power zoom lens

Connections

Caution:

The connection and installation should be done by qualified service personnel or system installers. Refer any servicing to qualified service personnel.

■ Connection of device with a composite input connector

- Connection to any device which has a composite input connector, such as a video monitor or a VTR, must be made through the VIDEO OUT connector.
- For DC power supply, use the optional AC adapter AW-PS505.

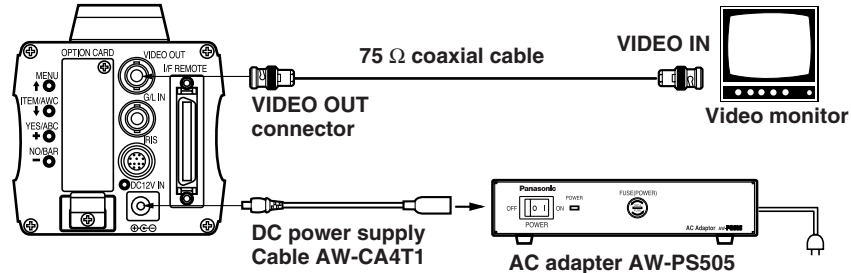

■ Connection of a remote control unit (RCU)

Connection to the RCU (WV-RC700A, WV-RC550) is made through the optional RCU cable AW-CA50A26.

1. Turn RCU power off before connecting cables.
2. Set the cable selection switch of the RCU to MULTI (in case of using the WV-RC700A)
3. Connect the 50-pin connector of the RCU cable to the I/F REMOTE connector of the camera.
4. Turn RCU power on and the power indicator lamp will light. The camera can now be remote controlled by the RCU.

Notes:

- The maximum extension distance between the camera and WV-RC700A is 300 m. The maximum extension distance between the camera and WV-RC550 is 100 m.
- Use the following options for cable extension.

Studio cable	WV-CA26U15 (15 m/50 ft)
	WV-CA26U30 (30 m/100 ft)
	WV-CA26U100 (100 m/330 ft)

Cable joint adapter
WV-CA26T26

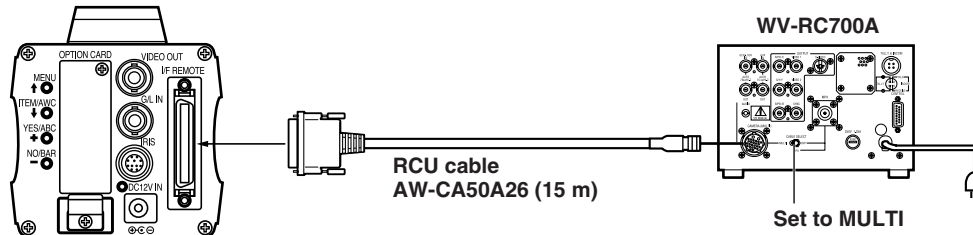

Connections

■ Connection of a remote control box (RCB)

The RCB (WV-CB700A) and the camera must be connected with the optional RCB cable AW-CA50T10.

1. Turn RCB power off before connecting cables.
2. Connect the 50-pin connector of the RCB cable to I/F REMOTE connector of the camera. The 10-pin connector must be connected to the RCB.
3. Turn RCB power on and the camera can be controlled remotely by the RCB.

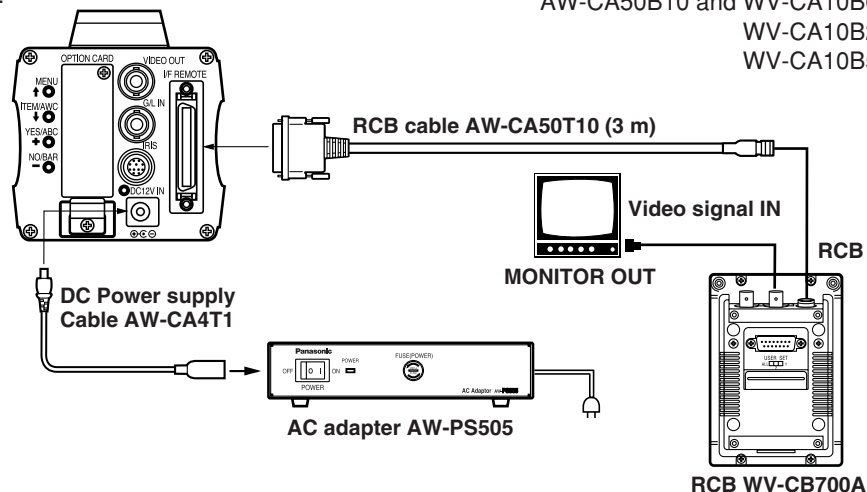

Notes:

- The monitor output signals of the RCB attenuate and deteriorate with cable length. It is recommended that the signals from the monitor output be used for monitoring purposes only.
- No gen-lock signal is available from the RCB.
- If a longer distance (more than 3 m) is desired between the camera and the RCB, use the following optional cable.
 - AW-CA50B10 and WV-CA10B02 (2 m)
 - WV-CA10B25 (25 m)
 - WV-CA10B50 (50 m)

■ Connection with multiple cameras (Color lock mode)

An example of connection for VBS/BB input (Color lock mode).

- One of the multiple cameras is used as the source of reference signals.
- Supply a synchronizing signal (BB) to the G/L input connectors of each cameras.

- Do not switch off the camera used for supplying the reference signals.
- Adjust the SC-phase and H-phase at the Video Output connector.

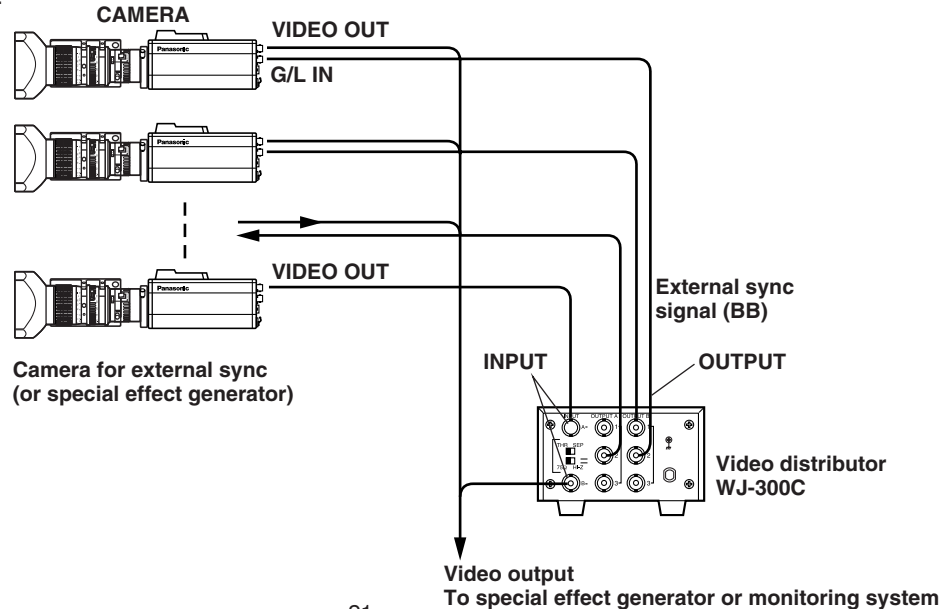

Connections

■ Connection of computer

The system shown here can remotely control this camera by using a computer.
The software and the cable for RS-232C required for this operation should be obtained locally.
Please contact qualified service personnel for this software.

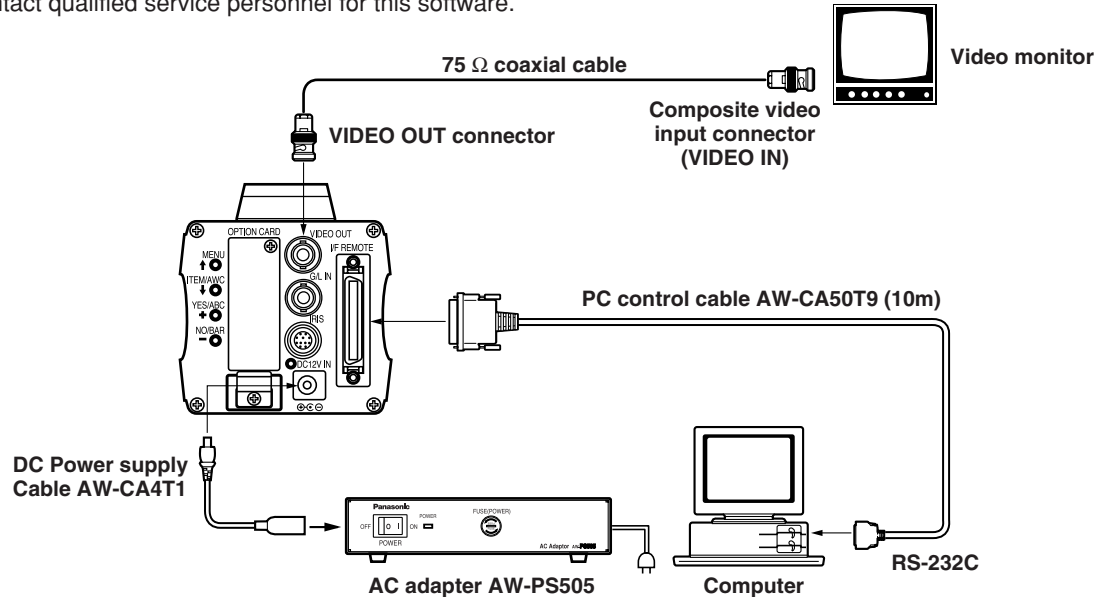

■ Connection of devices with camera pan/tilt control system

- Refer to the operating instructions of the pan/tilt head to connect camera to it.

Adjustment

■ Automatic white balance control (AWC)

There are two white balance memories, “AWC A” or “AWC B” for two different light sources color temperatures, with the automatic white balance setting. Then, when the two different light sources are encountered, you may operate the camera properly by simply change the white balance mode to either AWC A or AWC B. There is no need to readjust the camera to the ambient conditions.

✳ The preset conditions will be renewed whenever you input new conditions.

1. Turn the white balance selection switch to either “AWC A” or “AWC B” of RCU or select the white balance mode either AWC A or AWC B by menu.
2. Aim the camera at a white object (a white wall or a white handkerchief) and zoom in to enlarge the image as much as possible.

[ADJUSTMENT by CAMERA]

3. In normal shooting mode:
Press the ITEM/AWC switch for over 2 second.

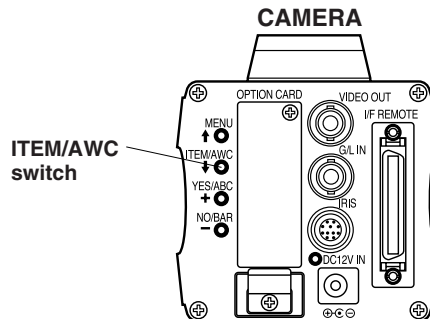

[ADJUSTMENT with the RCU (RCB, Hybrid control panel)]

4. When the AUTO set switch is turned to AWC, the white balance will be automatically set. While the system is being set, auto warning indicator (LED) blinks and it goes out when the white balance setting is completed. If the lamp remains lit, the setting must be tried again.

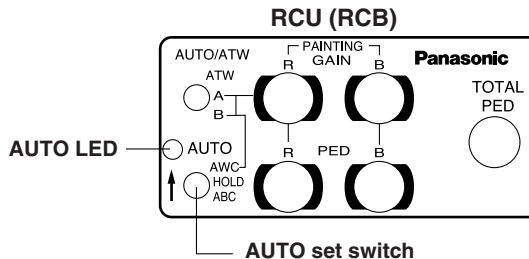

Adjustment

Notes:

- For white balance setting aim the camera at a white object and try to position it in the center of the monitor screen. The object must appear in over 10 % of the total monitor screen area. Try to avoid overly bright objects in the scene.
- White balance may not be correctly set if the lighting of the object is too weak.

The white object must occupy over 10 % of the monitor screen area.

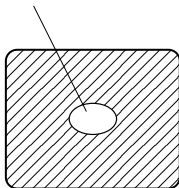

- Since the camera has a built-in memory, the set white balance will remain in the memory even if power is turned off. Therefore, it is not necessary to reset the white balance if the color temperature of those objects remains unchanged. However, it must be reset if the color temperature changes, such as when you move from indoors to outside, or vice versa.
- When the camera is used without a RCU or RCB red/blue gain adjustment of painting setting will be automatically reset to ± 0 after setting the white balance. (painting setting in only User Mode.)

■ Automatic tracking white balance setting (ATW)

White balance will be automatically set to continuously match changes of light source and color temperature while the white balance setting is set to ATW.

Notes:

- ATW might not function properly when high brightness light (ex. fluorescent lamp) beams into a screen.
- White balance may not be accurately set if there is no white object in the scene being shot.

■ Manual white balance setting

[ADJUSTMENT by CAMERA]

Manual setting is possible in User Mode only.

1. Select the white balance mode either AWC A or AWC B by menu.
2. Aim the camera at a large white object. Press the ITEM/AWC switch for over 2 second.
3. Adjust the red gain/blue gain control in the PAINTING item of Color Set sub menu of User Mode until the carrier wave of the white portion of the video signal is at the minimum width or the white object in the monitor screen appears pure white. (Use an oscilloscope or a waveform monitor for precise adjustment.)

[ADJUSTMENT with the RCU (RCB)]

After AWC setting, adjust the R/B GAIN controller in the same way as described in Step 3 above.

Minimize the carrier wave using the red & blue gain controls

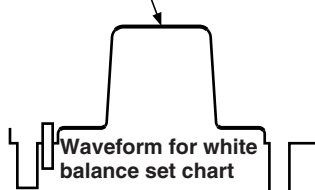

Reset to 3200K or 5600K white balance

When the white balance setting is set to either “3200K” or “5600K” the white balance will be automatically set to the color temperature 3200K or 5600K, respectively.

Black balance adjustment

- Close the lens.
If the motor drive lens is controlled from the camera, the lens is automatically closed when the black balance is adjusted.
- When the camera is used without a RCU or RCB, R/B pedestal adjustment of painting setting will be automatically reset to ± 0 after setting the black balance. (painting setting in only User Mode.)

[ADJUSTMENT by CAMERA]

Press the YES/ABC switch for over 2 seconds and the black balance will be set automatically in 10 seconds.

In user mode, black balance fine adjustment can be performed with the red pedestal/blue pedestal setting after setting the black balance.

[ADJUSTMENT with the RCU (RCB, Hybrid control panel)]

Set the AUTO set switch to ABC and the black balance will be automatically set. While the system is being set, the auto warning indicator (LED) blinks and it goes out when the black balance setting is completed. If the lamp remains lit, ABC should be tried again.

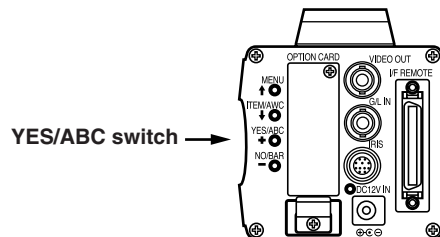

AUTO LED

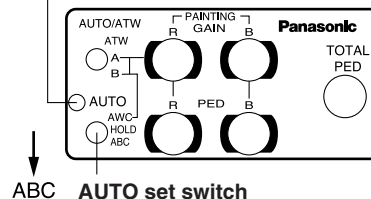

Adjustment

■ Total pedestal level adjustment

(Use an oscilloscope or a waveform monitor for this adjustment.)

This step is to adjust the black levels (pedestal levels) of two or more cameras to be the same.

[ADJUSTMENT by CAMERA]

1. Close the lens.
2. Select Pedestal item in the brightness setting Sub Menu.
(Select [Pedestal] in the [Iris, Shutter, Gain Set] sub menu in User Mode.)
3. Set the pedestal level to 5 IRE (0.035 V) with the YES/ABC switch or the NO/BAR switch.

[ADJUSTMENT with RCU (RCB, Hybrid control panel)]

Adjust the pedestal level to 5 IRE with the total pedestal adjustment.

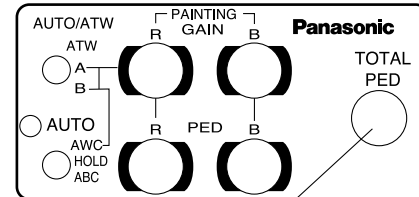
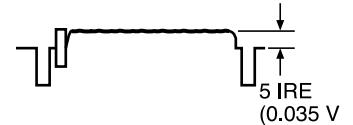
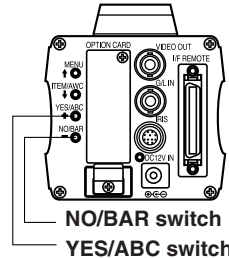
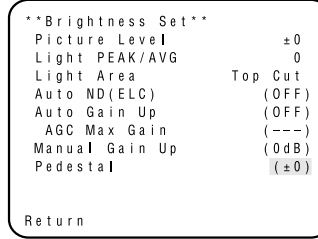

■ Gen-lock adjustment

Phase adjustments must be performed with the camera or the RCU (RCB) when external synchronizing signals are supplied to the system in cases where multiple cameras are used or peripheral devices are connected.

● Horizontal phase control

Observe the waveform of the external synchronizing input signal (black burst signal) and video output signal on a two-channel oscilloscope. Then match the horizontal phase of both signals by adjusting them with the cameras or RCU's horizontal phase control.

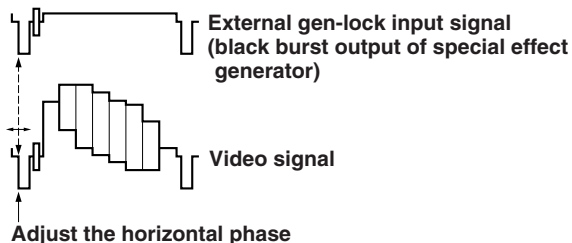

[ADJUSTMENT by CAMERA]

1. Press the NO/BAR switch for over 5 seconds to display the color bar.
2. Select [G/L Adjustment] on the main menu, then select [H Phase] on the submenu.
3. Adjust the horizontal phase with the YES/ABC and NO/BAR switch.

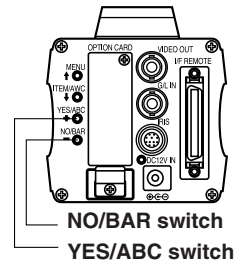
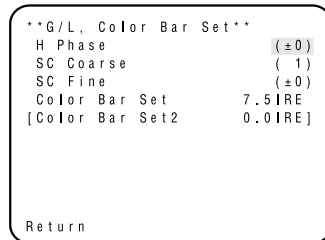

[ADJUSTMENT with RCU (RCB, Hybrid control panel)]

Use the horizontal phase control.

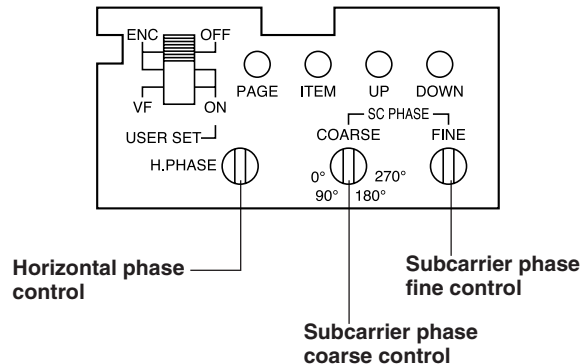

Adjustment

Caution:

- When horizontal phase adjustment is required using RCU (RCB) or hybrid control panel, BAR/CAM switch should be set to BAR. Horizontal phase cannot be adjusted if the switch is in the CAM position. After adjustment set BAR/CAM switch back to CAM.
- When horizontal phase adjustment is moved, color phase is also moved. Adjust color phase whenever horizontal phase adjustment is moved.

● Color phase adjustment

Supply the output signal (split color bar) from the color special effect generator to a color monitor or vectorscope. Adjust the color phase of the camera.

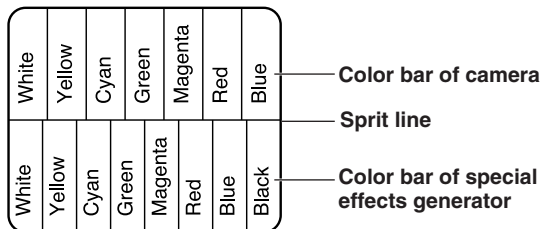

[ADJUSTMENT by CAMERA]

1. Press the NO/BAR switch for over 5 seconds for the color bar mode.
2. Select [G/L Adjustment] on the main menu, then select [SC Coarse] on the sub menu.
3. Make coarse adjustment with the YES/ABC switch and the NO/BAR switch.

4. Select [SC Fine] on the sub menu. Perform fine adjustment with the YES/ABC switch and the NO/BAR switch.

```

**G/L, Color Bar Set**
H Phase                (±0)
SC Coarse              ( 1)
SC Fine                (±0)
Color Bar Set          7.5IRE
[Color Bar Set2       0.0IRE]

Return
    
```

[ADJUSTMENT with RCU (RCB, Hybrid control panel)]

Use the subcarrier phase coarse adjustment control and subcarrier phase fine control.

※ It is recommended that a vectorscope be used for maximum accuracy in color phase adjustment.

Caution:

- When color phase adjustment is required using RCU (RCB) or hybrid control panel, BAR/CAM switch should be set to BAR. Color phase cannot be adjusted if the switch is in the CAM position. After adjustment set BAR/CAM switch back to CAM.
- When horizontal phase adjustment is moved, color phase is also moved. Adjust color phase whenever horizontal phase adjustment is moved.

Use mode setting

■ Use Mode Setting

The camera has four use modes, and various functions for four use modes have been preset.

Functions can be set as best suited to each use mode.

- Halogen mode
Suited to indoor shooting, such as at weddings, parties, lecture meetings, events, etc.
Settings can be changed using a simple menu.
- Fluorescent mode
Suited to indoor shooting under fluorescent lighting.
Settings can be changed using a simple menu.
- Outdoor mode
Suited to outdoor shooting.
Settings can be changed using a simple menu.
- User mode
Settings can be changed using a detail menu.

■ Setting by camera

1. Turn the camera on while keeping the MENU switch depressed.
The use mode setting menu shown at right appears on the monitor screen and one of the use mode blinks.

2. Press the MENU switch, ITEM/AWC switch, or NO/BAR switch to let the desired use mode blink.

MENU switch (↑):

The blinking item moves up by one.

ITEM/AWC switch (↓), NO/BAR switch (-):

The blinking item moves down by one.

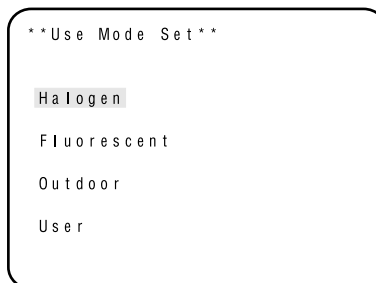

3. Press the YES/ABC switch.
The blinking use mode comes into effect. After the use mode setting menu is shown for about 5 seconds, the camera returns to be ready for operation.
Then, the camera operates in the selected use mode.

Use mode setting

■ Setting by RCU (RCB) or hybrid control panel

An operation mode is selected depending on the position of the scene file switch.

Operation mode	Scene File Switch Position of RCU (RCB)	Scene File Switch Position of Hybrid control panel
Halogen Mode	1	1
Fluorescent Mode	2	2
Outdoor Mode	3	3
User's Mode	USER SET	4

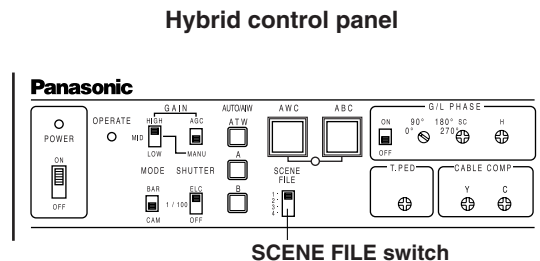
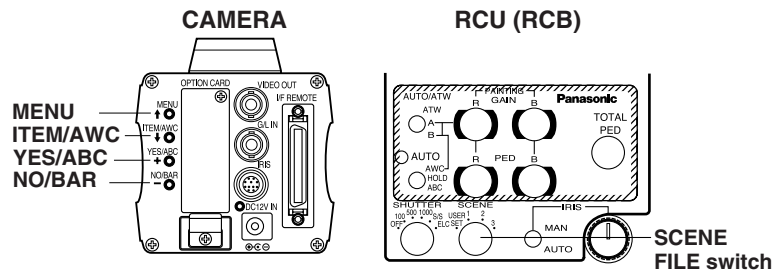

Menu item setting

■ Menu item setting

- Each of the four use modes of the camera has a main menu. (Shown at right)
- Each item of the main menu has a submenu, which consists of several settings.
- These settings have been preset to the optimum values to suit each use mode, and can be changed to suit actual shooting conditions.
- They can be set from the camera and RCU (RCB). They can also be set from the hybrid control panel using the switches, but the setting items are limited because the menu is not shown.

Notes:

- Composite signals are output from the video output regardless of the position ENC/VF of the RCU (RCB) user set switch.
- [End] is displayed only in setting from the camera alone.
- [Option Card1] is shown only when an optional card is inserted into the camera. [Option Card2] is shown only when an additional card box is equipped with the camera and then an optional card is inserted into the camera.

● Main menu screen

Main menu of Halogen,
Fluorescent, Outdoor Mode

```

**Halogen Mode Set**
  Brightness Set
  Color Set
  G/L, Color Bar Set
  Sharpness(DTL) Set
  Other Set
  Option Card Set

  Initialize Data

End

```

Use mode
Blinking

Main menu of User Mode

```

**User Mode Set**
  Iris, Shutter, Gain Set
  Color Set
  G/L, Color Bar Set
  Detail Set1 Detail Set2
  Color Matrix Set
  Other Set1 Other Set2
  Option Card Set

  Initialize Data

End

```

Menu item setting

* If the output signal from camera is color bar, only “G/L, Color Bar Set” screen is displayed.

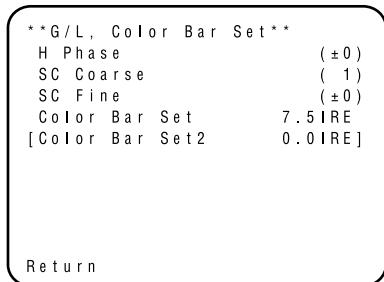

■ Setting

1. From the camera alone:

Keep the MENU switch depressed for 5 seconds or more.

From RCU (RCB):

Set the user set switch in the pocket to the ON position. The main menu appears on the monitor screen.

- Each time the MENU switch (↑), ITEM/AWC switch (↓), or NO/BAR switch (–) is pressed, the blinking item moves up or down.
- When the YES/ABC switch is pressed after selecting the desired item to blink, the submenu for the selected item appears on the screen.
- Select the desired item to be changed in its settings using the MENU switch (↑) and ITEM/AWC switch (↓).
- Press the YES/ABC switch (+) or NO/BAR switch (–) to change the settings.

6. Select [Return] using the MENU switch and ITEM/AWC switch, then press the YES/ABC switch to return to the main menu.

7. After changing the settings, take the following steps.

Camera alone:

Select [End] using the MENU switch and ITEM/AWC switch and press the YES/ABC switch.

RCU (RCB):

Set the user set switch in the pocket to the OFF position. The camera will now operate according to the new settings.

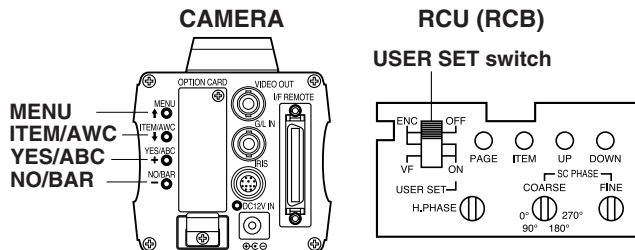

■ Changing the Language setting

The language on the menu screen can be changed from English to Japanese. (Factory setting: English)

- Halogen, Fluorescent, Outdoor Mode
Select “Japanese” in the “Language” setting in Other Set submenu.
- Use Mode
Select “Japanese” in the “Language” setting in Other Set2 submenu.

■ Sub menu (Halogen Mode, Fluorescent Mode, Outdoor Mode)

① Brightness Set Display

Brightness Set		
①	Picture Level	±0
②	Light PEAK/AVG	0
③	Light Area	Top Cut
④	Auto ND(ELC)	(OFF)
⑤	Auto Gain Up	(OFF)
⑥	AGC Max Gain	(---
⑦	Manual Gain Up	(0dB)
⑧	Pedestal	(±0)
Return		

③ G/L, Color Bar Set Display

G/L, Color Bar Set		
⑬	H Phase	(±0)
⑭	SC Coarse	(1)
⑮	SC Fine	(±0)
⑯	Color Bar Set	7.5IRE
⑰	[Color Bar Set2	0.0IRE]
Return		

⑤ Other Set Display

Other Set		
⑲	Contrast (Gamma)	Mid
⑳	Shutter Speed	(OFF)
㉑	Synchro Scan	---
㉒	V Resolution	Normal
㉓	Baud Rate	9600bps
㉔	Component	Y/Pr/Pb
㉕	Aspect Ratio	16:9
㉖	Fan SW	Auto
㉗	Language	English
Return		

② Color Set Display

Color Set		
⑨	Chroma Level	±0
⑩	Flesh Tone	±0
⑪	White Bal	(AWC A)
⑫	ATW Speed	---
Return		

④ Sharpness (DTL) Set Display

Sharpness (DTL) Set		
⑱	DTL Select	Sharpness
⑲	Level	(High)
⑳	Noise Suppress	OFF
㉑	Clean DNR	OFF
㉒	Flesh Noise Sup.	OFF
Return		

- Settings enclosed in parentheses can be set with the RCU (RCB) switch or VR in RCU (RCB) mode.
- Settings enclosed in [] is displayed when the optional card to process video signals (SDI card, etc.) is inserted.
- To return to the initial settings, refer to page 53.

Menu item setting

■ Setting and changing of the setting (Halogen Mode, Fluorescent Mode, Outdoor Mode)

① Brightness Set Display

- ❶ **Video Level Adjustment [Picture Level: -50 to +50]**
Convergence level of AUTO IRIS/AUTO GAIN UP/ AUTO ND (ELC) can be adjusted.

❷ Detecting Ratio Adjustment

[Light PEAK/AVG: P50 to A50]

The ratio of AUTO IRIS/AUTO GAIN UP/AUTO ND (ELC) detected peak to average can be adjusted within a predetermined range.

❸ Photometric Measurement Method Setting

[Light Area: All, Center, Top cut, BTM cut, R/L cut]

A photometric measurement method can be selected for AUTO IRIS/AUTO GAIN UP/AUTO ND (ELC).

All: All the screen area is measured.

Center: The screen is measured mainly in the center area, about one-third of both the top and bottom and one-third of both the right and left portions of the screen are excluded from measurement.

Top cut: About one-third of the top part of the screen is excluded from measurement.

BTM cut: About one-third of the bottom portion of the screen is excluded from measurement.

R/L cut: About one-third of both the right and left portions of the screen are excluded from measurement.

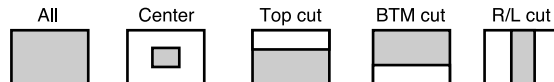

❹ Auto ND (ELC) Setting [Auto ND (ELC): OFF, ON]

OFF: Luminance is not automatically adjusted by the electronic shutter.

ON: The electronic shutter is controlled to automatically adjust the luminance.

Notes

- ON is automatically selected when the electronic shutter (24) on the submenu [Other Set] is set to [Auto ND]. OFF is selected when other than [Auto ND] is selected.
- ON is selected when the SHUTTER switch is set to [ELC] in RCU (RCB) mode, and OFF is selected when it is set to other than [ELC].

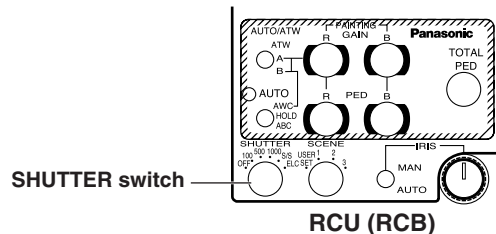

5 Auto Gain Up Control Setting [Auto Gain Up: OFF, ON]

OFF: The light quantity is not adjusted automatically.

ON: The light quantity is adjusted automatically. The maximum to which the gain can be increased using the auto gain up function is selected by the AGC maximum gain setting (6).

Notes

- In case of settings on the camera alone or when the iris switch on the RCU (RCB) is at [AUTO], the Auto Gain Up control may not operate if the lens iris switch is in the manual position.
- When the AGC switch on the hybrid control panel is set to AGC, the Auto Gain Up control operates in the HIGH position.

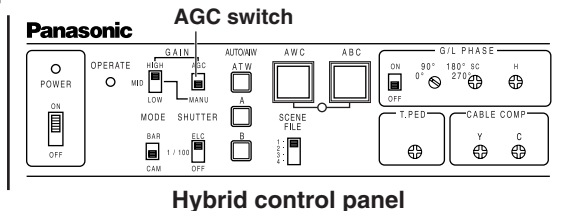

6 AGC Maximum Gain [AGC Max Gain: 6dB, 12dB, 18dB, 24dB, N/Eye L, N/Eye H]

This is used to set the maximum amount to which the gain can be increased when “ON” has been selected as the auto gain up setting (5).

7 Manual Gain Up Control Setting

[Manu Gain Up: 0 dB to 30 dB, N/Eye L, N/Eye H]

Manual setting is possible only when the Auto Gain Up control is in the OFF position.

0 dB: 0 dB should be selected in normal cases.

1 dB to 30 dB: Use this range if sufficient video output cannot be obtained even when the lens iris is opened in shooting dark scenes.

N/Eye L (Night Eye L):

Use this mode if sufficient video output cannot be obtained even if 30 dB gain up should be selected.

N/Eye H (Night Eye H):

Use this setting if it is not possible to achieve a satisfactory video output even at the Night Eye L setting.

Menu item setting

Notes

- Only 0 dB, 9 dB, or 18 dB can be selected in case of using the RCU (RCB).
- 0 dB when the manual GAIN switch on the hybrid control panel is at LOW, 9 dB when it is at MID, or 18 dB when it is at HIGH.

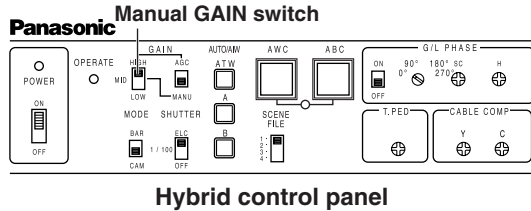

⑧ Black Level Setting [Pedestal: -150 to +150]

The black level (pedestal) of the luminance (Y) signal can be set. Used in adjusting the black levels of two or more cameras.

② Color Set Display

⑨ Chroma Level Adjustment [Chroma Level: -3 to +3]

Chroma Level can be decreased or increased to any of three levels each. The signal output to the optional card cannot be adjusted.

⑩ Skin Color Adjustment [Flesh Tone: -3 to +3]

Skin color can be decreased or increased to any of three levels each.

⑪ White Balance Setting

[White Bal: ATW, AWC A, AWC B, 3200K, 5600K]

ATW: The white balance is automatically adjusted to be always right.

AWC A, AWC B:

Once the white balance is adjusted with the ITEM/AWC switch on the back of the camera, it is no longer necessary to set the white balance again if you simply select AWC A or AWC B, provided that the camera is used under the same conditions.

Fine color adjustment can be made after setting AWC by red/blue gain adjustment in user mode or from the RCU (RCB).

3200K: The white balance is adjusted to 3200K illumination.

5600K: The white balance is adjusted to 5600K illumination.

Note

Neither 3200K nor 5600K can be set from the RCU (RCB) or the hybrid control panel.

12 ATW Speed Setting

[ATW Speed: Slow 2, Slow 1, Mid, Fast 1, Fast 2]

ATW Speed can be set.

3 G/L, Color Bar Set Display

13 Horizontal Phase Adjustment [H Phase: -206 to +49]

Horizontal phase can be adjusted when a genlock signal is supplied.

14 Subcarrier Phase Coarse Adjustment

[SC Coarse: 1, 2, 3, 4]

Coarse adjustment of subcarrier phase can be made when a genlock signal is supplied.

15 Subcarrier Phase Fine Adjustment

[SC Fine: -511 to +511]

Fine adjustment of subcarrier phase can be made when a genlock signal is supplied.

16 Color Bar Setup Setting

[Color Bar Set: 0.0 IRE, 7.5 IRE]

The setup level of color bar can be adjusted.

17 Color Bar Setup Setting for the optional cards

[Color Bar Set2: 0.0 IRE, 7.5 IRE]

This menu is displayed when the optional card to process video signals is inserted.

The setup level of color bar to output to the optional card can be adjusted.

Set 0.0 IRE when the SDI card is inserted.

Menu item setting

④ Sharpness (DTL) Set Display

⑬ Detail Select Setting [DTL Select: Sharpness, Super DTL]

If contour correction is not sufficient at the Sharpness position when Detail Level setting is set to Low or High, select the Super DTL position.

Note

Neither Sharpness nor Super DTL is valid for contour correction if Detail Level setting is in the OFF position.

⑭ Detail Level Setting [Level: OFF, Low, High]

Detail level can be adjusted when Detail Select setting is at Sharpness. Super DTL level can be adjusted when it is at Super DTL.

In case of using the RCU (RCB), the above can be adjusted with the contour correction switch (DTL).

⑳ Noise Suppress Level Setting

[Noise Suppress: OFF, Low, High]

Screen noise can be reduced when Detail Level setting is at High or Low.

㉑ Clean DNR Setting [Clean DNR: OFF, Low, High]

This enables the clean DNR effect to be selected.

㉒ Flesh Noise Suppress Level Setting

[Flesh Noise Sup.: OFF, Low, High]

Flesh noise is suppressed in two steps when the Detail Level Setting is at High or Low.

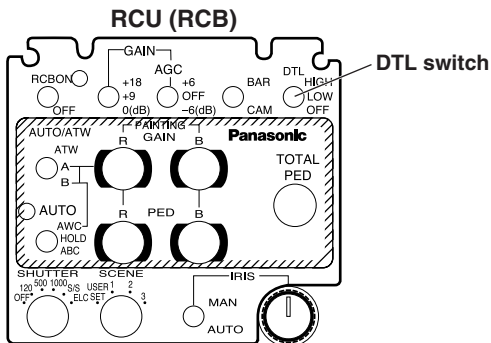

⑤ Other Set Display

⑳ Contrast Adjustment

[Contrast (Gamma): Low, Mid, High]

Contrast can be adjusted to any of three levels.

㉑ Electronic Shutter Setting [Shutter Speed: OFF, 1/100 to 1/10000, S/Scan, Auto ND]

OFF: Electronic shutter is turned off.

1/100, 1/250, 1/500, 1/1000, 1/2000, 1/4000, 1/10000:

Electronic shutter operates at one of these speeds as selected.

S/Scan (Synchro Scan):

Electronic shutter operates at the speed set with the electronic shutter synchro-scan setting.

Auto ND: Electronic shutter is controlled to automatically adjust the luminance.

Notes

- In case of using the RCU (RCB), none of the shutter speeds — 1/250, 1/2000, 1/4000, and 1/10000 can be selected.
- In case of using the hybrid control panel, only OFF, 1/100, or Auto ND (ELC) can be selected.
- If the lens iris switch is at M (Manual) when operating the camera alone or when the iris switch on the RCU (RCB) is at AUTO, Auto ND may not function. Set the lens iris switch to A (Auto).
- Flickering may increase at Auto ND under fluorescent lights.
- Auto ND is automatically selected if Auto ND (ELC) setting is set to ON.

㉒ Electronic Shutter Synchro Scan Setting [Synchro Scan: 60.34Hz to 15.75kHz]

This setting is possible only when Electronic Shutter setting is at S/Scan.

Horizontal bar noise can be reduced by synchro-scan adjustment in shooting workstation scenes, for example.

※ For luminance settings at each shutter speed and synchro-scan shutter speed, refer to the table below.

Shutter Speed	Synchro-scan	Required luminance ratio
OFF	—	1
1/100	100.3 Hz	2
1/250	250.0 Hz	4
1/500	492.2 Hz	8
1/1000	984.4 Hz	16
1/2000	1.969 kHz	32
1/4000	3.938 kHz	64
1/10000	7.875 kHz	160

㉓ CCD Read Out Mode Setting [V Resolution: Normal, Fine]

Normal: Normal image. (CCD storage will be by field storage.)

Fine: Vertical resolution increases. (Vertical resolution is raised without increasing residual images by frame storage and Electronic shutter.)
Normal is recommended for general use because sensitivity will decrease at the Fine setting.

Menu item setting

27 PC Control Access Speed Setting

[Baud Rate: 1200bps, 2400bps, 4800bps, 9600bps]

Select a communication speed in controlling the camera from the computer.

28 Component Output Setting

[Component: RGB, Y/Pr/Pb, Y/C]

This enables RGB, Y/Pr/Pb or Y/C to be selected as the component signals which are to be output from the I/F REMOTE connector.

29 Aspect Ratio Selection [Aspect Ratio: 16:9, 4:3]

Aspect ratio can be selected from 16:9 or 4:3.

30 Fan Setting [Fan SW: OFF, Auto]

OFF: Select this setting to stop the fan when its operating sound is found to be bothersome in a studio or other such environment.

Auto: The temperature is detected automatically, and the fan starts operating when the temperature exceeds approx. 95°F (35°C).

Under normal circumstances, the “Auto” setting is used.

31 Language Selection [Language: English, Japanese]

English: Menu screen is displayed in English.

Japanese: Menu screen is displayed in Japanese.

■ Sub menu (User Mode)

⑥ Iris, Shutter, Gain Set Display

Iris, Shutter, Gain Set		
32	Picture Level	±0
33	Light PEAK/AVG	0
34	Light Area	Top Cut
35	Auto Iris Adjust	OFF
36	Shutter Mode	(Step)
37	Step/Synchro	(OFF)
38	Gain	(0dB)
39	AGC Max Gain	(---)
Return		

⑧ G/L, Color Bar Set Display

G/L, Color Bar Set		
45	H Phase	(±0)
46	SC Coarse	(1)
47	SC Fine	(±0)
48	Color Bar Set	7.5IRE
49	[Color Bar Set2	0.0IRE]
Return		

⑨ Detail Set Display

Detail Set1		
50	Detail	(High)
51	H Detail Level H	20
52	V Detail Level H	19
53	H Detail Level L	13
54	V Detail Level L	8
55	Detail Band	5
56	Noise Suppress	3
57	Level Dependent	0%
58	Dark Detail	0
Return		

⑦ Color Set Display

Color Set		
40	Chroma Level	+2
41	White Bal	(AWC A)
42	ATW Speed	---
43	Pedestal	(±0)
44	Painting	
	R Gain	(±0)
	B Gain	(±0)
	R Pedestal	(±0)
	B Pedestal	(±0)
Return		

Detail Set2		
59	Chroma Detail	0
60	Flesh Noise Sup.	OFF
61	Precision Detail	OFF
Return		

Menu item setting

⑩ Color Matrix Set Display

62

Color Matrix Set 1		
B_Mg Gain		±0
B_Mg Phase		±0
Mg Gain	+27	
Mg Phase		±0
Mg_R Gain		±0
Mg_R Phase		±0
R Gain	+15	
R Phase		±0

62

Color Matrix Set 3		
G_Cy Gain		±0
G_Cy Phase		±0
Cy Gain	+44	
Cy Phase	-15	
Cy_B Gain		±0
Cy_B Phase		±0
B Gain	-20	
B Phase	+36	

Return

Color Matrix Set 2		
R_YI Gain		±0
R_YI Phase		±0
YI Gain	+18	
YI Phase	+6	
YI_G Gain		±0
YI_G Phase		±0
G Gain	+30	
G Phase	+112	

⑪ Other Set Display

Other Set1		
63	Gamma	0.45
64	Knee Point	98%
65	White Clip	110%
66	Flare R	0
	Flare G	0
	Flare B	0
67	Black Stretch	OFF
68	Clean DNR	OFF

Return

Other Set2		
69	Field/Frame	Field
70	Baud Rate	9600bps
71	Component	Y/Pr/Pb
72	Aspect Ratio	16:9
73	Fan SW	Auto
74	Language	English

Return

- Settings enclosed in parentheses can be set with the RCU (RCB) switch or VR in RCU (RCB) mode.
- Settings enclosed in [] is displayed when the optional card to process video signals (SDI card, etc.) is inserted.
- To return to the initial settings, refer to page 53.

■ Setting and changing of the setting items (User Mode)

⑥ Iris, Shutter, Gain Set Display

③2 Video Level Adjustment [Picture Level: -50 to +50]

Convergence level of AUTO IRIS, AUTO GAINUP, ELC can be adjusted.

③3 Detecting Ratio Adjustment

[Light PEAK/AVG: P50 to A50]

The ratio of AUTO IRIS, AUTO GAINUP, ELC detected peak to average can be adjusted within a range.

③4 Photometric Measurement Method Setting

[Light Area: All, Center, Top cut, BTM cut, R/L cut]

A photometric measurement method can be selected for AUTO IRIS, AUTO GAINUP, ELC.

All: All the screen area is measured.

Center: The screen is measured mainly in the center area, about one-third of both the top and bottom and one-third of both the right and left portions of the screen are excluded from measurement.

Top cut: About one-third of the top portion of the screen is excluded from measurement.

BTM cut: About one-third of the bottom portion of the screen is excluded from measurement.

R/L cut: About one-third of both the right and left portions of the screen are excluded from measurement.

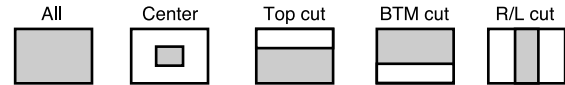

③5 Auto Iris Level Fine Adjustment

[Auto Iris Adjust: OFF, ON]

OFF: The iris control is invalid when the iris switch on the RCU (RCB) or on the hybrid control panel is in the AUTO position.

ON: Fine adjustment of auto iris convergence level can be made with the iris control when the iris switch on the RCU (RCB) or on the hybrid control panel is in the AUTO position.

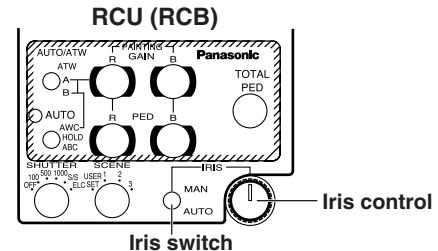

Menu item setting

36 Electronic Shutter Mode Setting

[Shutter Mode: Step, S/Scan, ELC]

Step: Electronic shutter operates at the speed selected by the Electronic Shutter Step/Synchro Scan Setting.

S/Scan (Synchro Scan):

Electronic shutter operates at the speed selected in Electronic Shutter Step/Synchro Scan Setting.

ELC: Electronic shutter is controlled to automatically adjust the luminance.

Note

If Frame 1 is selected in CCD Read Out Mode Setting (69), Electronic Shutter Mode Setting cannot be added.

37 Electronic Shutter Step/Synchro Scan Setting

[Step/Synchro: OFF, 1/100 to 1/10000 (Step), 60.34 Hz to 15.75kHz (Synchro Scan)]

This setting is possible only when Step or Synchro Scan is selected in Electronic Shutter Mode Setting.

• When “Step” has been selected as the electronic shutter mode setting:

OFF: Electronic shutter is turned off.

1/100, 1/250, 1/500, 1/1000, 1/2000, 1/4000, 1/10000:

Electronic shutter operates at one of these speeds as selected.

• When “Synchro Scan” has been selected as the electronic shutter mode setting:

Bar noise can be reduced by synchro-scan adjustment in shooting workstation scenes, for example.

※ For luminance setting at each shutter speed and synchro-scan shutter speed, refer to the table below.

Shutter Speed	Synchro-scan	Required luminance ratio
OFF	—	1
1/100	100.3 Hz	2
1/250	250.0 Hz	4
1/500	492.2 Hz	8
1/1000	984.4 Hz	16
1/2000	1.969 kHz	32
1/4000	3.938 kHz	64
1/10000	7.875 kHz	160

Notes

- In case of using the RCU (RCB), none of the shutter speeds — 1/250, 1/2000, 1/4000, and 1/10000 can be selected.
- In case of using the hybrid control panel, only OFF, 1/100, or ELC can be selected.
- If the lens iris switch is at M (Manual) when operating the camera alone or when the iris switch on the RCU (RCB) is at AUTO, ELC may not function. Set the lens iris switch to A (Auto).
- Flickering may increase at ELC under fluorescent lights.

38 Gain Setting

[Gain: Auto, 0 dB to 30 dB, N/Eye L, N/Eye H]

Auto: The light quantity is adjusted automatically.

0 dB: 0 dB should be selected in normal cases.

1 dB to 30 dB: Use this range if sufficient video output cannot be obtained even when the lens iris is opened in shooting dark scenes.

N/Eye L (Night Eye L):

Use this mode if sufficient video output cannot be obtained even if 30 dB gain up should be selected.

N/Eye H (Night Eye H):

Use this setting if it is not possible to achieve a satisfactory video output even at the Night Eye L setting.

Notes

- Only 0 dB, 9 dB, or 18 dB, AGC LOW, AGC HIGH can be selected in case of using the RCU (RCB). If the lens iris switch is at MANUAL, when operating the camera alone or when the iris switch on the RCU (RCB, Hybrid control panel) is at AUTO, AGC may not function.
- AGC HIGH when the AGC selection switch on the hybrid control panel is at AGC.
- 0 dB when the manual gain switch on the hybrid control panel is at LOW, 9 dB when it is at MID, or 18 dB when it is at HIGH.

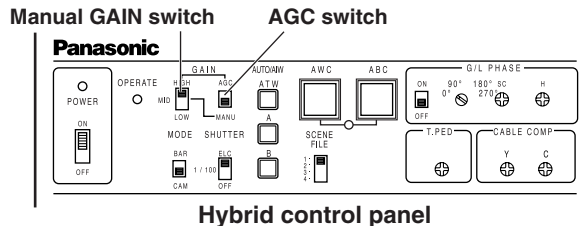

Menu item setting

39 AGC Maximum Gain Setting

[AGC Max Gain: 6dB, 12dB, 18dB, 24dB, N/Eye L, N/Eye H]

This is used to set the maximum gain up when “Auto” has been selected as the gain setting.

7 Color Set Display

40 Chroma Level Adjustment [Chroma Level: -3 to +3]

Chroma Level can be decreased or increased to three levels. The signal output to the optional card cannot be adjusted.

41 White Balance Setting

[White Bal: ATW, AWC A, AWC B, 3200K, 5600K]

ATW: The white balance is automatically adjusted to the optimum position.

AWC A, AWC B:

Once the white balance is adjusted with the ITEM/AWC switch on the back of the camera, it is no longer necessary to set the white balance again if you simply select AWC A or AWC B, provided that the camera is used under the same conditions.

Fine color adjustment can be made after setting AWC by red/blue gain adjustment in User Mode or from the RCU (RCB).

3200K: The white balance is adjusted to 3200K illumination.

5600K: The white balance is adjusted to 5600K illumination.

Note

Neither 3200K nor 5600K can be set from the RCU (RCB) or the hybrid control panel.

42 ATW Speed Setting

[ATW Speed: Slow 2, Slow 1, Mid, Fast 1, Fast 2]

ATW Speed can be set.

43 Black Level Setting [Pedestal: -150 to +150]

The black level (pedestal) of the luminance (Y) signal can be set. Used in adjusting the black levels of two or more cameras.

44 Painting Setting

[Painting: R Gain, B Gain, R Pedestal, B Pedestal: -150 to +150]

R Gain, B Gain:

Fine adjustment of the white balance can be made after AWC setting when AWC A or AWC B is selected in White Balance Setting. In case of using the RCU (RCB), use the R/B gain controls for this purpose. The set value returns to ± 0 after AWC setting in using the camera alone.

R Pedestal, B Pedestal:

Fine adjustment of the black balance can be made after ABC setting. In case of using the RCU (RCB), use the R/B pedestal controls for this purpose. The set value returns to ± 0 after ABC setting in using the camera alone.

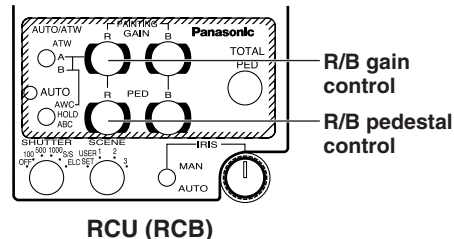

RCU (RCB)

Menu item setting

⑧ G/L, Color Bar Set Display

④5 Horizontal Phase Adjustment [H Phase: -206 to +49]

Horizontal phase can be adjusted when a genlock signal is supplied.

④6 Subcarrier Phase Coarse Adjustment

[SC Coarse: 1, 2, 3, 4]

Coarse adjustment of subcarrier phase can be made when a genlock signal is supplied.

④7 Subcarrier Phase Fine Adjustment

[SC Fine: -511 to +511]

Fine adjustment of subcarrier phase can be made when a genlock signal is supplied.

④8 Color Bar Setup Setting

[Color Bar Set: 0.0 IRE, 7.5 IRE]

The setup level of color bar can be adjusted.

④9 Color Bar Setup Setting for the optional cards

[Color Bar Set2: 0.0 IRE, 7.5 IRE]

This menu is displayed when the optional card to process video signals is inserted.

The setup level of color bar to output to the optional card can be adjusted.

Set 0.0 IRE when the SDI card is inserted.

⑨ Detail Set Display

⑤0 Detail Level Setting [Detail: OFF, Low, High]

Contour correction quantity can be selected.

Detail settings made using the Horizontal/Vertical Detail Level High/Low Setting.

⑤1 Horizontal Detail Level High Setting

[H Detail Level H: L+1 to 63]

⑤2 Vertical Detail Level High Setting

[V Detail Level H: L+1 to 31]

⑤3 Horizontal Detail Level Low Setting

[H Detail Level L: 0 to H-1]

⑤4 Vertical Detail Level Low Setting

[V Detail Level L: 0 to H-1]

Detail level can be set in horizontal (H) and vertical (V) directions with the Detail Level Setting at High or Low. Whichever the direction, H or V, the set level at High must be at least one position higher than that at Low.

⑤5 Detail Band Setting [Detail Band: 1 to 5]

A contour correction band can be set with the Detail Level Setting at High or Low. The higher setting, the finer will be the detail.

56 Noise Suppress Level Setting

[Noise Suppress: 1 to 10]

Screen noise can be reduced with the Detail Level Setting at High or Low. If the noise suppress level is set too high, a fine object will be reproduced less sharply.

57 Level Dependent Level Setting

[Level Dependent: 0% to 25%]

Screen noise due to the detail of dark parts of an object can be reduced.

If level dependent level is set too high, however, hair, for example, will be reproduced less sharply.

58 Dark Detail Level Setting [Dark Detail: 0 to 5]

The contours of the darker portions of an object can be emphasized.

This setting is possible only when the Level Dependent Level Setting is set to 0%.

59 Chroma Detail Level Setting [Chroma Detail: 0 to 15]

The contours of high-hue portions of an object can be emphasized.

60 Flesh Noise Suppress Level Setting

[Flesh Noise Sup.: OFF, Low, High]

Flesh noise is suppressed in two steps when the Detail Level Setting is at High or Low.

61 Precision Detail Level Setting

[Precision Detail: OFF, Low, High]

This setting is to narrow detail width and suppress detail glare.

Menu item setting

⑩ Color Matrix Set Display

⑥② **B_Mg Gain:** Increases or decreases the intermediate color between blue and magenta.

B_Mg Phase: Varies the hue of the intermediate color between blue and magenta.

Mg Gain: Increases or decreases the magenta.

Mg Phase: Varies the hue of the magenta.

Mg_R Gain: Increases or decreases the intermediate color between magenta and red.

Mg_R Phase: Varies the hue of the intermediate color between magenta and red.

R Gain: Increases or decreases the red.

R Phase: Varies the hue of the red.

R_YI Gain: Increases or decreases the intermediate color between red and yellow.

R_YI Phase: Varies the hue of the intermediate color between red and yellow.

YI Gain: Increases or decreases the intermediate color of yellow.

YI Phase: Varies the hue of the yellow.

YI_G Gain: Increases or decreases the intermediate color between yellow and green.

YI_G Phase: Varies the hue of the intermediate color between yellow and green.

G Gain: Increases or decreases the green.

G Phase: Varies the hue of the green.

G_Cy Gain: Increases or decreases the intermediate color between green and cyan.

G_Cy Phase: Varies the hue of the intermediate color between green and cyan.

Cy Gain: Increases or decreases the cyan.

Cy Phase: Varies the hue of the cyan.

Cy_B Gain: Increases or decreases the intermediate color between cyan and blue.

Cy_B Phase: Varies the hue of the intermediate color between cyan and blue.

B Gain: Increases or decreases the intermediate color between blue and magenta.

B Phase: Varies the hue of the intermediate color between blue and magenta.

① Other Set Display

⑥③ Gamma Level Setting [Gamma: 0.35 to 0.55]

Gamma correction level can be set.

⑥④ Knee Level Setting

[Knee Point: 88% to 98%, Dynamic]

88% to 98%: The level of video signals subject to knee (knee point) can be set.

Dynamic: Knee level is automatically adjusted according to the scene.

⑥⑤ White Clip Level Setting [White Clip: 95% to 110%]

The peak level of video signals to be white-clipped can be set.

⑥⑥ Flare Correction Level Setting [Flare R/G/B: 0 to 100]

Flare correction level can be adjusted.

⑥⑦ Black Stretch Setting [Black Stretch: ON, OFF]

Black stretch to correct the suppression of black portions at low luminance can be set to ON or OFF.

⑥⑧ Clean DNR Setting [Clean DNR: OFF, Low, High]

This enables the clean DNR effect to be selected.

⑥⑨ CCD Read Out Mode Setting

[Field/Frame: Field, Frame 1, Frame 2]

Field: CCD storage will be by field storage.

Frame 1: Vertical resolution increases in frame storage.

Frame 2: Vertical resolution is raised without increasing residual images by frame storage and electronic shutter.

⑦⑦ PC Control Access Speed Setting [Baud Rate: 1200bps, 2400bps, 4800bps, 9600bps]

This setting is to select a communication speed in controlling the camera from the computer.

⑦① Component Output Setting [Component: RGB, Y/Pr/Pb, Y/C]

This enables RGB, Y/Pr/Pb or Y/C to be selected as the component signals which are to be output from the I/F REMOTE connector.

⑦② Aspect Ratio Selection [Aspect Ratio: 16:9, 4:3]

Aspect ratio can be selected from 16:9 or 4:3.

⑦③ Fan Setting [Fan SW: OFF, Auto]

OFF: Select this setting to stop the fan when its operating sound is found to be bothersome in a studio or other such environment.

Auto: The temperature is detected automatically, and the fan starts operating when the temperature exceeds approx. 95°F (35°C).

Under normal circumstances, the "Auto" setting is used.

⑦④ Language Selection [Language: English, Japanese]

English: Menu screen is displayed in English.

Japanese: Menu screen is displayed in Japanese.

Setting and changing the optional cards

12 Optional Card Setting Sub Menu

This sub menu appears when a studio card (AW-PB305 or AW-PB506) has been inserted into the optional card slot.

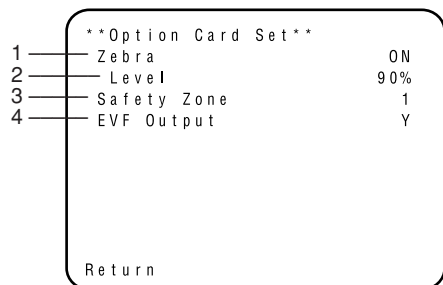

1. Zebra Indicator Setting [Zebra: OFF, ON]

This is used to select whether to display the zebra pattern on the viewfinder.

OFF: The zebra pattern is not displayed on the viewfinder.

ON: The zebra pattern is displayed on the viewfinder.

2. Zebra Level Setting [Level: 70% to 110%]

This enables the zebra pattern to be displayed so that it will provide as a general guideline for the luminance level.

※ It can be set when “ON” has been selected as the zebra indicator setting.

3. Safety Zone Setting [Safety Zone: OFF, 1, 2, 3, 4, 5]

This is used to select the type of safety zone which is displayed on the viewfinder. A safety zone is not displayed when “OFF” is selected.

※ The safety zone and center marker indicate electrical positions and, as such, they may be at variance with their optical positions.

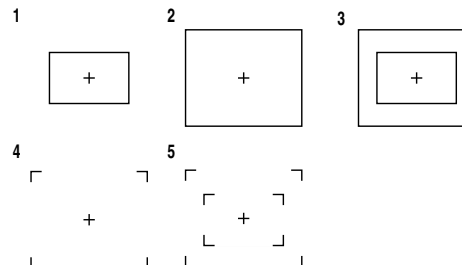

The inside and outside frames denote safety zones of about 90% and about 95%, respectively.

4. EVF Output Setting [EVF Output: Y, CVBS]

This is used to set the signals to be output to the viewfinder.

Y: The luminance signal is output to the viewfinder.

CVBS: The color signals are output to the viewfinder.

※ When “CVBS” has been selected as the setting, the zebra pattern will not be displayed on the viewfinder.

Setting to initial set

■ Setting to initial set

In case of the wrong setting in any use mode, take the following steps to return to the initial settings.

- (1) Select [Initialize Data] on the main menu screen of each Use Mode. (See page 29.)
Press the YES/ABC switch, then [Initialize Data] screen shown for about 10 seconds.
- (2) Press the YES/ABC switch within about 10 seconds to return to the initial settings, the existing settings are initialized, the screen shown at ②, and the camera returns to main menu.

- (3) If the NO/BAR switch is pressed, or if the YES/ABC switch is not pressed, within about 10 seconds, the screen shown at ③, and the camera returns to main menu, and the existing settings are not initialized.

Note

If you are using an option card, the Option Card Setting Submenu will not be initialized even if “Return to Initialize” is performed.

①

```
**Initialize Data**  
(Halogen Mode)
```

```
Do you want to  
initialize Halogen  
Mode settings?
```

```
O.K. : YES SW  
Cancel : NO SW
```

②

```
Halogen Mode
```

```
Initialized
```

③

```
Halogen Mode
```

```
Unchanged
```

■ Initial settings of the setting items (Factory preset values)

● Halogen, Fluorescent, Outdoor Mode

	Item	Halogen mode	Fluorescent mode	Outdoor mode
Brightness Set	Picture Level	±0	±0	±0
	Light PEAK/AVG	0	0	0
	Light Area	Top cut	Top cut	Top cut
	Auto ND (ELC)	OFF	OFF	ON
	Auto Gain Up	OFF	OFF	ON
	AGC Max Gain	---	---	N/Eye H
	Manu Gain Up	0dB	0dB	---
Color Set	Pedestal	±0	±0	-40
	Chroma Level	±0	+0	+0
	Flesh Tone	±0	±0	±0
	White Bal	AWC A	AWC A	ATW
	ATW Speed	---	---	Mid
G/L, Color Bar Set	H Phase	±0	±0	±0
	SC Coarse	1	1	1
	SC Fine	±0	±0	±0
	Color Bar Set	7.5 IRE	7.5 IRE	7.5 IRE
	Color Bar Set 2	0.0 IRE	0.0 IRE	0.0 IRE
Sharpness (DTL) Set	DTL Select	Sharpness	Sharpness	Sharpness
	Level	High	High	High
	Noise Suppress	OFF	OFF	OFF
	Clean DNR	OFF	OFF	OFF
Other Set	Flesh Noise Sup.	OFF	OFF	OFF
	Contrast (Gamma)	Mid	Mid	Mid
	Shutter Speed	OFF	OFF	Auto ND
	Synchro Scan	---	---	---
	V Resolution	Normal	Normal	Normal
	Baud Rate	9600bps	9600bps	9600bps
	Component	Y/Pr/Pb	Y/Pr/Pb	Y/Pr/Pb
	Aspect Ratio	16:9	16:9	16:9
	Fan SW	Auto	Auto	Auto
	Language	(English)	(English)	(English)

Note

When the optional card is inserted to the camera, "Language" menu will not be returned to default setting even if "Initialize Data" menu is executed.

● User Mode

	Item	User mode		Item	User mode
Iris, Shutter, Gain Set	Picture Level	±0	Detail Set 1	Detail	High
	Light PEAK/AVG	0		H Detail Level H	20
Color Set	Light Area	Top cut	V Detail Level H	19	
	Auto Iris Adjust	OFF	H Detail Level L	13	
	Shutter Mode	Step	V Detail Level L	8	
	Step/Synchro	OFF	Detail Band	5	
	Gain	0dB	Noise Suppress	3	
	AGC Max Gain	---	Level Dependent	0%	
	Chroma Level	+2	Dark Detail	0	
	White Bal	AWC A	Detail Set 2	Chroma Detail	0
	ATW Speed	---		Flesh Noise Suppress	OFF
	Pedestal	±0		Precision Detail	OFF
Painting R Gain	±0				
B Gain	±0				
R Pedestal	±0				
B Pedestal	±0				
G/L, Color Bar Set	H Phase	±0			
	SC Coarse	1			
	SC Fine	±0			
	Color Bar Set	7.5 IRE			
Color Bar Set2	0.0 IRE				

Setting to initial set

	Item	User mode		Item	User mode
Color Matrix Set	B_Mg Gain	±0	Other Set 1	Gamma	0.45
	B_Mg Phase	±0		Knee Point	88%
	Mg Gain	+27		White Clip	110%
	Mg Phase	±0		Flare R	0
	Mg_R Gain	±0		Flare G	0
	Mg_R Phase	±0		Flare B	0
	R Gain	+15		Black Stretch	OFF
	R Phase	±0		Clean DNR	OFF
	R_YI Gain	±0	Other Set 2	Field/Frame	Field
	R_YI Phase	±0		Baud Rate	9600bps
	YI Gain	+18		Component	Y/Pr/Pb
	YI Phase	+6		Aspect Ratio	16:9
	YI_G Gain	±0		Fan SW	Auto
	YI_G Phase	±0		Language	(English)
	G Gain	+30			
	G Phase	+112			
	G_Cy Gain	±0			
	G_Cy Phase	±0			
	Cy Gain	+44			
	Cy Phase	-15			
Cy_B Gain	±0				
Cy_B Phase	±0				
B Gain	-20				
B Phase	+36				

Note

When the optional card is inserted to the camera, "Language" menu will not be returned to default setting even if "Initialize Data" menu is executed.

Appearance

Unit: inch (mm)

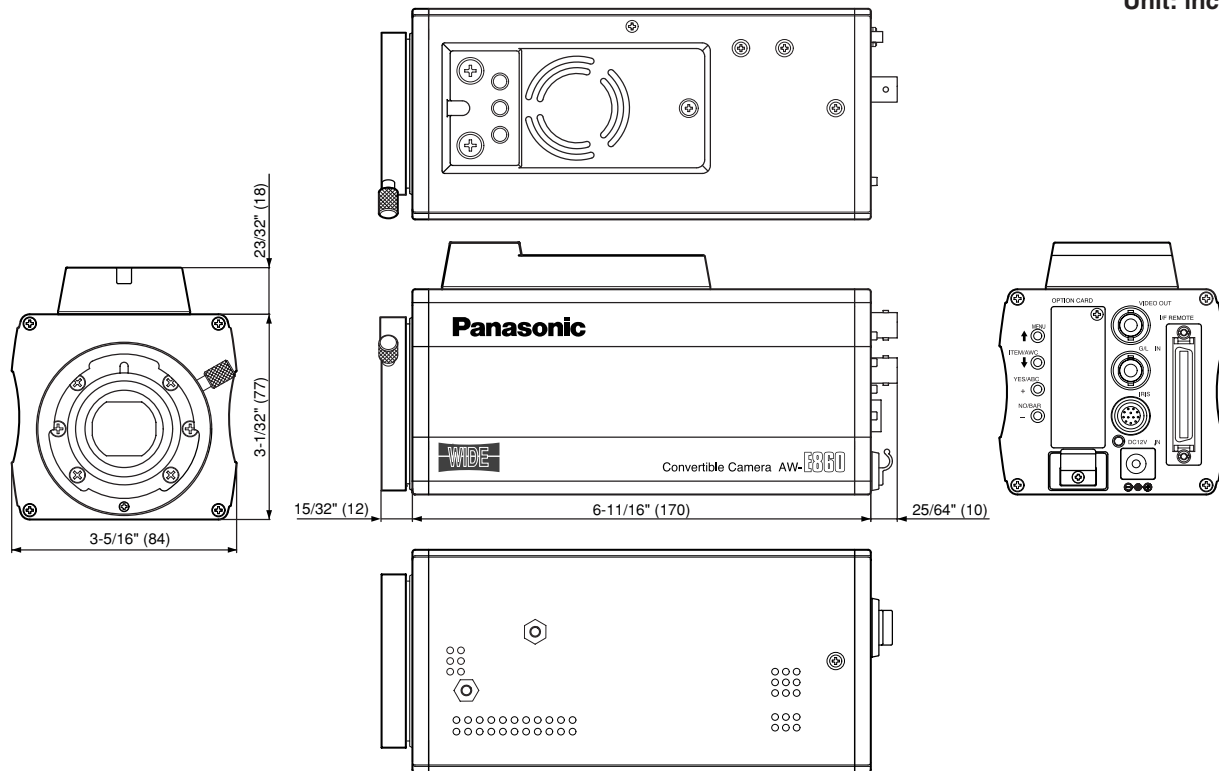

Specifications

Source voltage: DC 12V

Power consumption: 15.4 W

 indicates safety information.

Optical system: 2/3" Prism optical system, F1.4
Pickup device: 2/3" interline wide CCD
Number of valid pixels: 948 (H) × 485 (V) (About 460000 pixels)
Total number of pixels: 1020 (H) × 505 (V) (About 510000 pixels)
Scanning system: 525 lines, 60 fields, 30 frames
Synchronization system: Internal synchronization: EIA standard
External synchronization: BBS or VBS (BNC × 1, Dsub 50 P × 1)
Video output: Composite: 1.0 Vp-p/75Ω (BNC × 1, Dsub 50 P × 1)
Y/C Y: 1.0 Vp-p/75Ω; C: 0.286 Vp-p/75Ω (burst) (Dsub 50 P × 1)
Y/Pr/Pb Y: 1.0 Vp-p/75Ω; Pr, Pb: 0.7 Vp-p/75Ω (Dsub 50 P × 1)
RGB G: 1.0 Vp-p/75Ω; RB: 0.7 Vp-p/75Ω (Dsub 50 P × 1)
Standard illumination color temperature: 2,000 lx (F11, 3200K)
Minimum illumination: 0.4 lx (F1.7, Night Eye H)
S/N ratio: 65 dB (Y signal, DTL OFF, gamma OFF, DNR ON)
Horizontal resolution: 850 TV lines (high band DTL ON, center area)
Registration: 0.05 % (Entire screen, excluding effects of lens)
Geometric distortion: 0%
Aspect ratio conversion: 16 : 9, 4 : 3
Contour correction: Horizontal, vertical (2H)
White balance: AWC A, AWC B (R/B gain, painting), ATW, 3200K, 5600K preset
Black balance: Auto (R/B pedestal, painting function)

Chroma amount variability: 7 levels variability
Encoding system: Y, R-Y, B-Y
Gain selection: 0 to 30 dB in step, AGC, Night Eye L/H
Electronic shutter speed: 1/100, 1/250, 1/500, 1/1000, 1/2000, 1/4000, 1/10000, ELC, Synchro scan (60.34 Hz to 15.75 kHz)
CCD readout selection: Field, Flame 1, Flame 2
Color bars: SMPTE
Lens mount: 2/3" bayonet mount
Lens diaphragm: Auto, Manual (only with remote control), Adjust ON, OFF
Selectors: MENU (↑)
ITEM/AWC (↓) (AWC: when menu screen is not displayed)
YES/ABC (+) (ABC: when menu screen is not displayed)
NO/BAR (-) (BAR: when menu screen is not displayed)
Input/Output connectors: VIDEO OUT: BNC connector
G/L IN: BNC connector
IRIS: 12 P round connector
DC 12 V IN: DC connector
I/F REMOTE: 50 P Dsub connector
Indicator: Red LED lits: POWER ON
Allowable temperature ranges:
For storage: -4°F to 140°F (-20°C to +60°C)
For guaranteeing performance: 41°F to 95°F (+5°C to +35°C)
For guaranteeing operation: 14°F to 113°F (-10°C to +45°C)
Allowable humidity ranges: For storage: 20% to 90%, for operation: 20% to 90%
Dimensions (W × H × D): 3-5/16" × 3-3/4" × 7-9/16" (84 × 95 × 192 mm)
Weight: 2.5 lbs (1.15 kg)

Weight and dimensions indicated are approximate.
Specifications are subject to change without notice.

Standard accessories

Rubber sheet 1
Mounting adapter 1

Screw 2
Mounting spacer 1

Panasonic®

PANASONIC BROADCAST & TELEVISION SYSTEMS COMPANY
UNIT COMPANY OF PANASONIC CORPORATION OF NORTH AMERICA

Executive Office:

One Panasonic Way 4E-7, Secaucus, NJ 07094 (201) 348-7000

EASTERN ZONE:

One Panasonic Way 4E-7, Secaucus, NJ 07094 (201) 348-7621

Southeast Region:

1225 Northbrook Parkway, Ste 1-160, Suwanee, GA 30024 (770) 338-6835

Central Region:

1707 N Randall Road E1-C-1, Elgin, IL 60123 (847) 468-5200

WESTERN ZONE:

3330 Cahuenga Blvd W., Los Angeles, CA 90068 (323) 436-3500

Government Marketing Department:

52 West Gude Drive, Rockville, MD 20850 (301) 738-3840

Broadcast PARTS INFORMATION & ORDERING:

9:00 a.m. – 5:00 p.m. (EST) (800) 334-4881/24 Hr. Fax (800) 334-4880

Emergency after hour parts orders (800) 334-4881

TECHNICAL SUPPORT:

Emergency 24 Hour Service (800) 222-0741

Panasonic Canada Inc.

5770 Ambler Drive, Mississauga, Ontario L4W 2T3 (905) 624-5010

Panasonic de Mexico S.A. de C.V.

Av angel Urraza Num. 1209 Col. de Valle 03100 Mexico, D.F. (52) 1 951 2127

Panasonic Puerto Rico Inc.

San Gabriel Industrial Park, 65th Infantry Ave., Km. 9.5, Carolina, Puerto Rico 00630 (787) 750-4300

© 2005 Matsushita Electric Industrial Co., Ltd. All rights reserved.

