

**INDURO®**

INDURO Camera Support Gear | 75 Virginia Road, North White Plains, NY 10603 | T 914-347-3300 | F 914-347-3309 | info@indurogear.com | indurogear.com

**INDURO®**

## **BHD-SERIES BALLHEAD OPERATING INSTRUCTIONS**

Thank you for making Induro your choice for professional photographic gear. Your Induro gear is manufactured to provide years of dependable service. In order to obtain optimum satisfaction and performance we suggest that you carefully read these instructions and provide them to anyone who may also use your Induro gear.

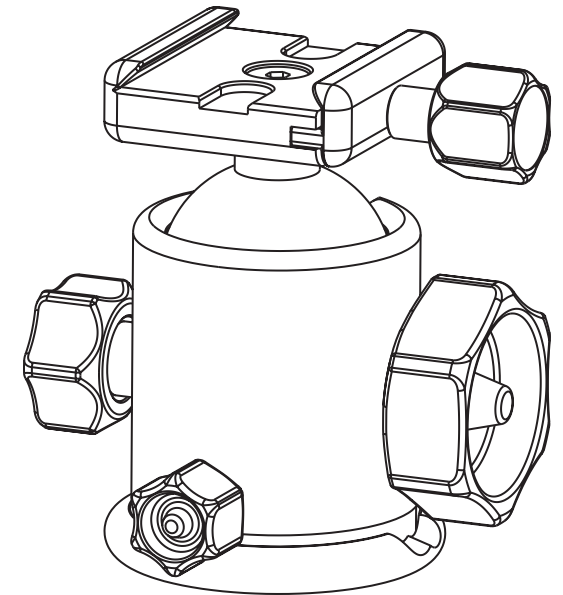

Specifications and design are subject to change without notice.

All tradenames, logos, and brand references are the respective trademarks of their owners.

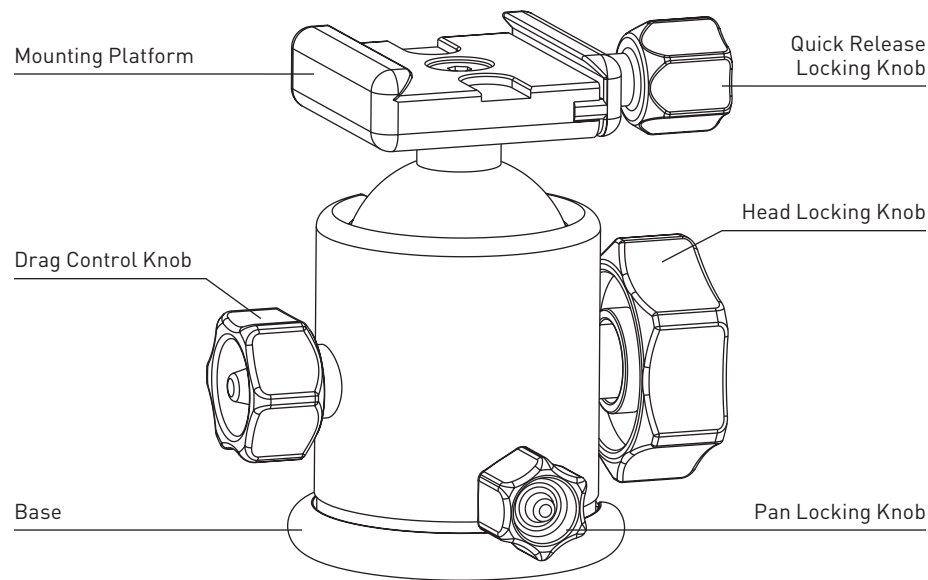

## SETUP

### Head Mounting

Install by screwing the head clockwise onto the 3/8" mounting thread of the top plate of the Tripod or Monopod. Once it is hand tight, if available, secure by fully tightening the Head Locking Screw(s) from below with the included Allen Key.

### OPERATION

The BHD-Series Ballheads are professional black anodized machined aluminum and feature three operating Knobs. Drag control is manually adjusted and locked, along with independent Panning. Plus a Universal Quick Release Clamp with secondary Safety Lock System is incorporated.

### Universal Quick Release Plate System

The BHD-Series Ballheads feature a Universal Arca-Swiss style Quick Release Plate system. It offers a quick method of mounting or releasing a Camera or Equipment from the Head. It's important that the correct Quick Release Plate be used along with the proper mounting screw (1/4-20 is included as the standard size but spare 1/4-20 and 3/8 plates of various lengths are available as accessories). The Mounting Screw requires an Allen Key which is included. Extra Plates are recommended as you can screw one to each Camera or Lens for even greater convenience when rapidly mounting and dismounting gear. And because of compatibility with the Universal Arca-Swiss style system, most plates and special brackets from other manufacturers can be used as well.

### Quick Release Lock (FIGURE 1)

When used properly, the Quick Release Lock offers two levels of security for your gear. To remove the Quick Release Plate, turn the Quick Release Locking Knob counter-clockwise. A partial opening of the clamping mechanism allows the Quick Release Plate to slide on the Mounting Platform for proper balance and positioning. Two Stop Screws (removable) on the bottom of the Quick Release Plate provide this first level of security. An additional counter-clockwise turn of the Quick Release Locking Knob opens the clamp fully so that the Quick Release Plate can be tilted out to be removed. Reverse the process and tighten the Quick Release Locking Knob to secure the Quick Release Plate.

### Ballhead Controls (FIGURE 2)

A large Head Locking Knob locks the Ballhead in place. Once the Knob is turned counter-clockwise and loosened, the Ballhead can move freely allowing the Mounting Platform to be positioned anywhere within a 0-90° vertical orientation. This movement is expanded by the use of the Pan Locking Knob which adds a 360° Panning range. The Pan control is fully

independent and positioning can be adjusted easily and accurately by using the Graduated Panning Scale and Pointer on the Base of the Ballhead.

When the Head Locking Knob is released, it is possible to move the Ballhead with some resistance or Drag. To achieve the proper degree of Drag, mount the intended camera or equipment onto the Ballhead. While holding the camera/lens loosen the Head Locking Knob until it is released. Turn the Drag Control Knob clockwise to increase Drag, and counter-clockwise to decrease it.

FOR OPTIMUM RESULTS: Adjust the Drag under the weight capacity, temperature and conditions under which the Ballhead will be used.

NOTE: Do not over tighten any Locking Knobs as this could damage the Ballhead locking mechanism.

### USER NOTICE

- ① Do not exceed the maximum specified load capacity (see specifications on the package label or visit [www.indurogear.com](http://www.indurogear.com)).
- ① Always ensure that all Ballhead locks are tightly engaged before mounting any gear.
- ① Do not use any Ballhead below temperatures of -4°F or above +158°F (-20°C / +70°C).
- ① Always clean and dry any Ballhead after it has been exposed to wet, dusty, sandy or salty conditions. Your Ballhead is not recommended for use in salt water. If required, clean Ballhead using a mild soap solution applied with a soft cloth, rinse with fresh water and dry with soft towel. Remove any dust, dirt or sand from all locks and all moving parts.
- ① Do not leave any Ballhead in the sun for prolonged periods and avoid high temperature exposure.
- ① Avoid leaving any Tripod or Monopod unattended in areas where people could trip over the gear and get hurt.
- ① Remove camera, lens, and all gear from any Tripod or Monopod when transporting.
- ① For your safety, don't let your Induro gear come in contact with any electrical power source.

