



Glide Gear

G2H 100

USER MANUAL



What's included?

Rail Cap x2 (D)



Camera Plate (E)

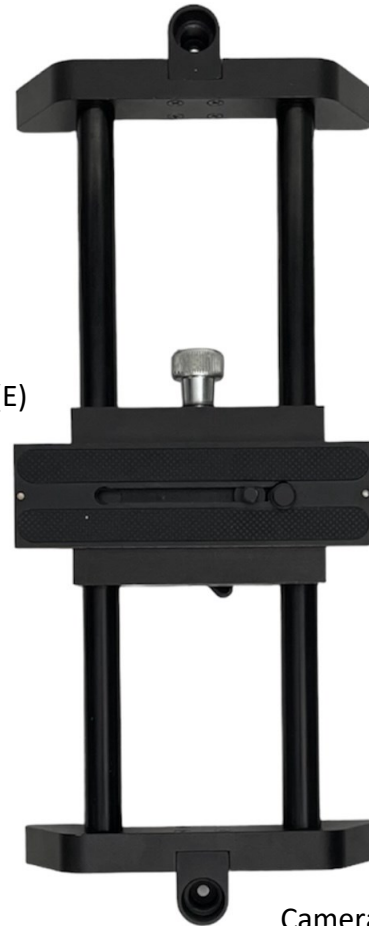

Vertical Rail x2 (C)



Camera Rails (B)

Main Frame (A)

Handle (F)

For more information please visit our website: www.glidegear.net



Assembly

- 1 Attach the Vertical Rails (C) to the ends of the Camera Rails (B) as shown in Fig. 1. Make sure to insert the Vertical Rails (C) so that the measurements are in the correct orientation.



Fig. 1

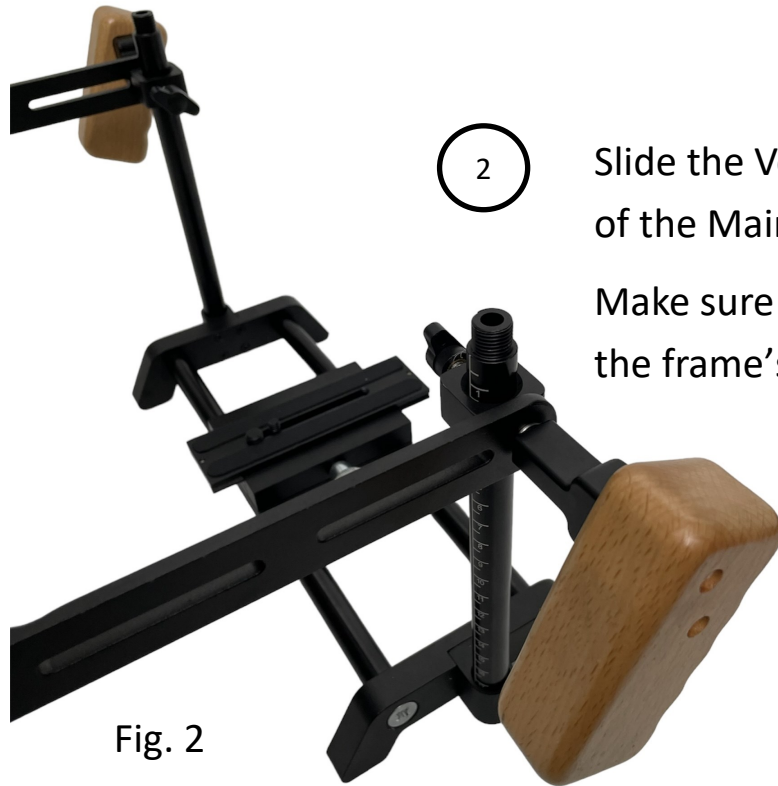

Fig. 2

- 2 Slide the Vertical Rails (C) onto the clamps located at the end of each arm of the Main Frame (A). Make sure that the Main Frame (A) wooden handles are facing away from the frame's arms as pictured in Fig. 2.

- 3 Screw the Rail Caps (D) at the end of each Vertical Rails (C) as shown in Fig. 3.



Fig. 3

- 4 You can now mount your camera onto the Camera Plate (E).

For more information please visit our website: www.glidegear.net



Adjustments

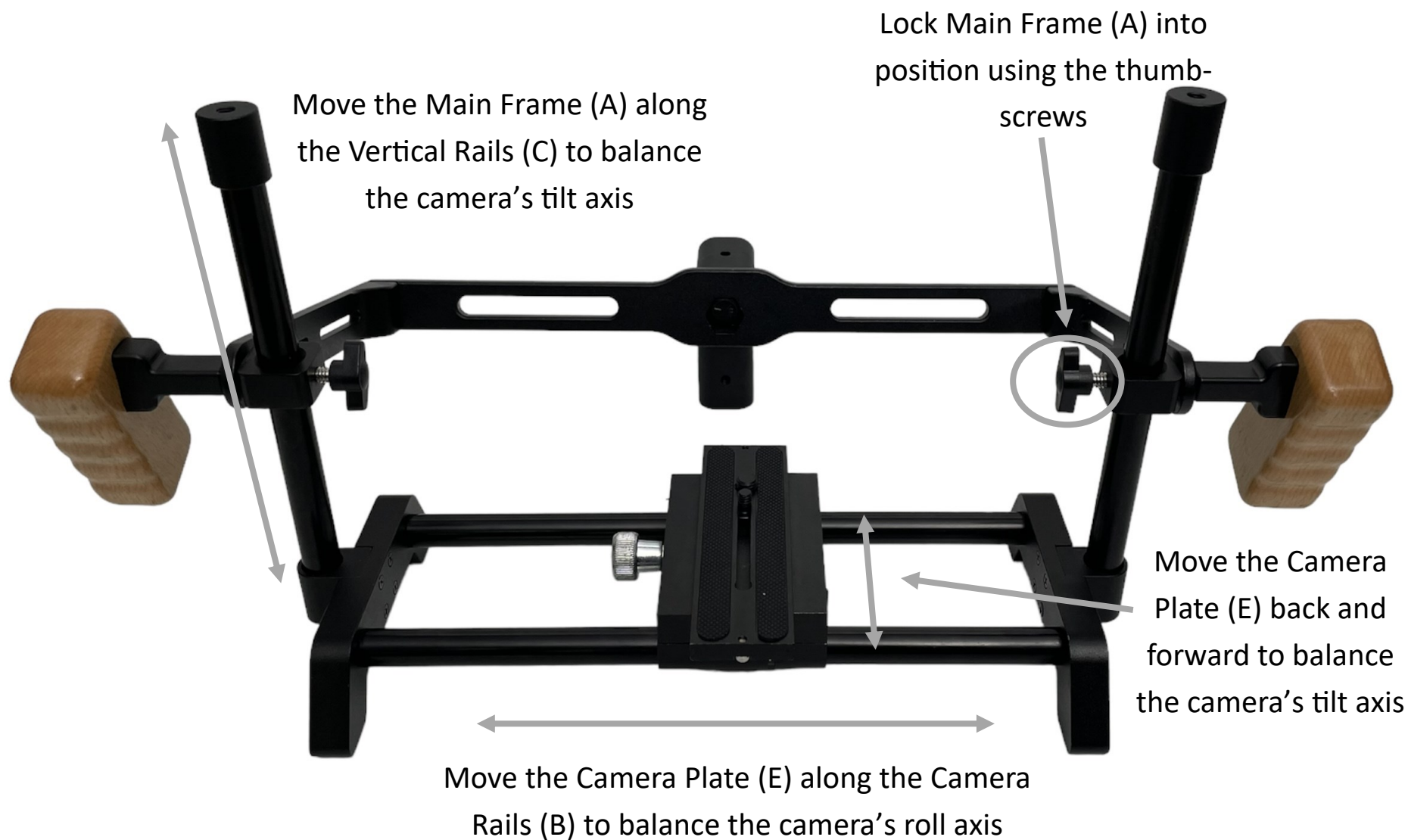

For more information please visit our website: www.glidegear.net



Using the G2H 100 with a vest and arm system

PLEASE NOTE that the **G2H 100** needs to be used in combination with a **Vest and Arm system** and is compatible with any vest and arm system with a pin diameter smaller than 7/8" or 22.5mm

To use the G2H 100 with your vest and arm system, simply slide the arm's pin inside the G2H 100 handle (F) as shown in Fig. 4

Glide Gear recommends using The G2H 100 with the G2G 1000 Vest.

The G2G 1000 Vest can be used with the arm mounted to the front of the vest as it is usually the case but can also be used with the arm mounted to the back of the vest as it is the case in Fig. 5 which also features the G2H 100.

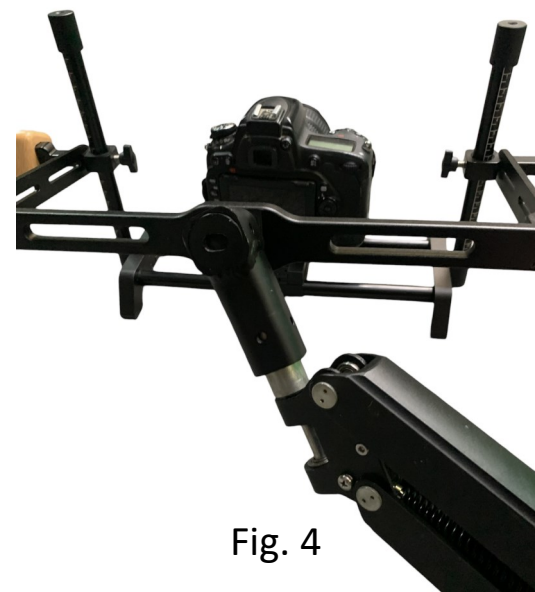

Fig. 4



Fig. 5

For more information please visit our

website: www.glidegear.net