



Kodak

ScanMate i1120 Scanner

User's Guide

User's Guide on Installation CD
Guide d'utilisation sur le CD d'installation
Benutzerhandbuch auf der Installations-CD
Manuale per l'utente sul CD di installazione
Guía del usuario en el CD de instalación
Guia do Usuário no CD de instalação
Gebruikershandleiding op installatie-cd
Kurulum CD'sindeki Kullanım Kılavuzu
Uživatelská příručka na instalačním disku CD
安裝光盘上的用户指南
安裝光碟上的《使用者指南》
インストールCDのユーザガイド
설치 CD의 사용 설명서
دليل المستخدم على القرص المضغوط الخاص بالتنصيب
Руководство пользователя на установочном компакт-диске
Ghidul utilizatorului de pe CD-ul de instalare
Felhasználói útmutató a telepítő CD-n
Podręcznik użytkownika na instalacyjnym dysku CD
Οδηγός χρήσης στο CD εγκατάστασης

Safety

User precautions

- Place the scanner on a sturdy, level work surface capable of supporting 2.6 kg (5.72 lbs).
- Do not install the scanner in a location subject to dust, humidity or steam. This may cause electrical shock or fire.
- Make sure the electrical power outlet is located within 1.52 meters (5 feet) of the scanner and is easily accessible.
- Use only the power cord that was provided with the scanner. Using any other power cord may cause electrical shock and/or damage the product.
- Be sure the power cord is securely plugged into the wall outlet. Failure to do so may cause electrical shock or fire.
- Do not damage, knot, cut or modify the power cord. This may cause electrical shock or fire.
- The scanner requires a dedicated power outlet. Do not use an extension cord or power strip with the scanner.
- Use only the AC adapter that is supplied with the scanner; Model HEG42-240200-7L. Do not use the scanner's AC adapter with any other product.
- Leave sufficient space around the power outlet so it can be easily unplugged in case of an emergency.
- Do not use the scanner if it becomes inordinately hot, has a strange odor, emits smoke, or makes unfamiliar noises. Immediately stop the scanner and disconnect the power cord from the power outlet. Contact Kodak Service.
- Do not disassemble or modify the scanner or the AC power adapter.
- Do not move the scanner with the power cord and USB cable attached. This may cause damage to the cord/cable. Remove the power cord from the wall outlet before moving the scanner.
- Material Safety Data Sheets (MSDS) for chemical products are available on the Kodak website at: www.kodak.com/go/msds. When accessing the MSDSs from the website, you will be required to provide the catalog number of the consumable you want the Material Safety Data Sheet for. See the section entitled, "Supplies and consumables" later in this guide for supplies and catalog numbers.

Environmental information

- The *Kodak ScanMate i1120* Scanner is designed to meet worldwide environmental requirements.
- Guidelines are available for the disposal of consumable items that are replaced during maintenance or service; follow local regulations or contact Kodak locally for more information.
- The *Kodak ScanMate i1120* Scanner contains lead in the circuit board solder, glass lens, mercury in the lamps, and Chromium VI used as corrosion protection on the metal frame. Disposal of this material may be regulated due to environmental considerations. For disposal or recycling information, contact your local authorities or, in the USA, visit: www.kodak.com/go/scannerrecycling.
- The product packaging is recyclable.
- The *Kodak ScanMate i1120* Scanner is Energy Star compliant and is shipped from the factory with the default time set to 15 minutes.

EMC statements

United States: This equipment has been tested and found to comply with the limits for a Class B digital device pursuant to Part 15 of the FCC rules. These limits are designed to provide reasonable protection against harmful interference in a residential installation. This equipment generates, uses, and can radiate radio frequency energy and, if not installed and used in accordance with the instruction manual, may cause harmful interference to radio communications. However, there is no guarantee that interference will not occur in a particular installation. If this equipment does cause harmful interference to radio or television reception, which can be determined by turning the equipment off and on, the user is encouraged to try to correct the interference by one or more of these measures:

- Reorient or relocate the receiving antenna.
- Increase the separation between the equipment and receiver.
- Connect the equipment into an outlet on a circuit different from that to which the receiver is connected.
- Consult the dealer or an experienced radio/TV technician for additional suggestions.

Any changes or modifications not expressly approved by the party responsible for compliance could void the user's authority to operate the equipment. Where shielded interface cables have been provided with the product or specified additional components or accessories elsewhere defined to be used with the installation of the product, they must be used in order to ensure compliance with FCC regulation.

Korea: As this equipment has obtained EMC registration for household use, it can be used in any area including residential areas.

기기는 가정용으로 전자파적합등록을 한 기기로서 주거지역에서는 물론 모든 지역에서 사용할 수 있습니다.

Japan: This is a Class B product based on the standard of the Voluntary Control Council for interference by information Technology Equipment (VCCI). If this is used near a radio or television receiver in a domestic environment, it may cause radio interference. Install and use the equipment according to the instruction manual.

この装置は、情報処理装置等電波障害自主規制協議会（VCCI）の基準に基づくクラスB情報技術装置です。この装置は、家庭環境で使用することを目的としていますが、この装置がラジオやテレビジョン受信機に近接して使用されると、受信障害を引き起こすことがあります。
取扱説明書に従って正しい取り扱いをして下さい。

Acoustic emission

Maschinenlärminformationsverordnung – 3, GSGV
Der arbeitsplatzbezogene Emissionswert beträgt <70 dB(A).

[Machine Noise Information Ordinance — 3, GSGV
The operator-position noise emission value is <70 dB(A).]

Power system connection

This product is also designed for Norwegian IT power system with phase-to-phase voltage 230V.

European Union



This symbol indicates that when the last user wishes to discard this product, it must be sent to appropriate facilities for recovery and recycling. Please contact your local Kodak representative or refer to www.kodak.com/go/recycle for additional information on the collection and recovery programs available for this product.



OVERVIEW

1-1

INSTALLATION

2-1

SCANNING

3-1

MAINTENANCE

4-1

TROUBLESHOOTING

5-1

APPENDICES

1 Overview

Contents

Supporting documentation	1-1
What's in the box	1-1
Scanner components	1-2

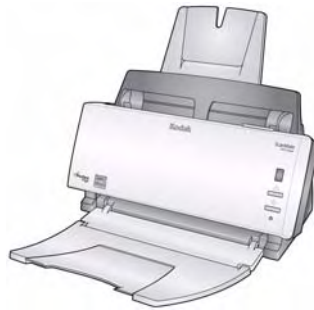

The *Kodak ScanMate i1120* Scanner is a desktop, duplex color scanner that scans two sides of a document in a single pass at 20 pages per minute. The scanner can accommodate documents up to 21.6 x 86 cm / 8.5 x 34 inches using the 50-sheet automatic document feeder.

Supporting documentation

In addition to this User's Guide, the following documentation is also available:

- **Installation Guide** — provides a step-by-step procedure for installing the scanner.
- **Scanning Setup Guides** — the TWAIN Datasource and ISIS Driver are included with the *Kodak i1120* Scanner. The Scanning Setup Guides explain how to use basic image processing features and is provided on the Installation CD in PDF format.
- **Smart Touch User's Guide** — provides information and procedures on how to use Smart Touch functionality. This guide is provided on the Installation CD in PDF format.

What's in the box

Before you begin open the box and check the contents:

- *Kodak ScanMate i1120* Scanner
- Input tray
- Output tray
- Pre-separation pad (spare)
- USB 2.0 cable
- Power supply
- AC power cord bundles
- Welcome Folio:
 - Installation CD (includes: *Kodak* Smart Touch functionality, *Kodak* drivers and software)
 - Application CDs (includes ScanSoft PaperPort, ScanSoft OmniPage and BizCard5)
 - Warranty/Registration sheets
 - Printed User's Guide, English
 - Installation Guide
 - Service & Support Country Contact sheet
 - Miscellaneous flyers

Scanner components

Front view

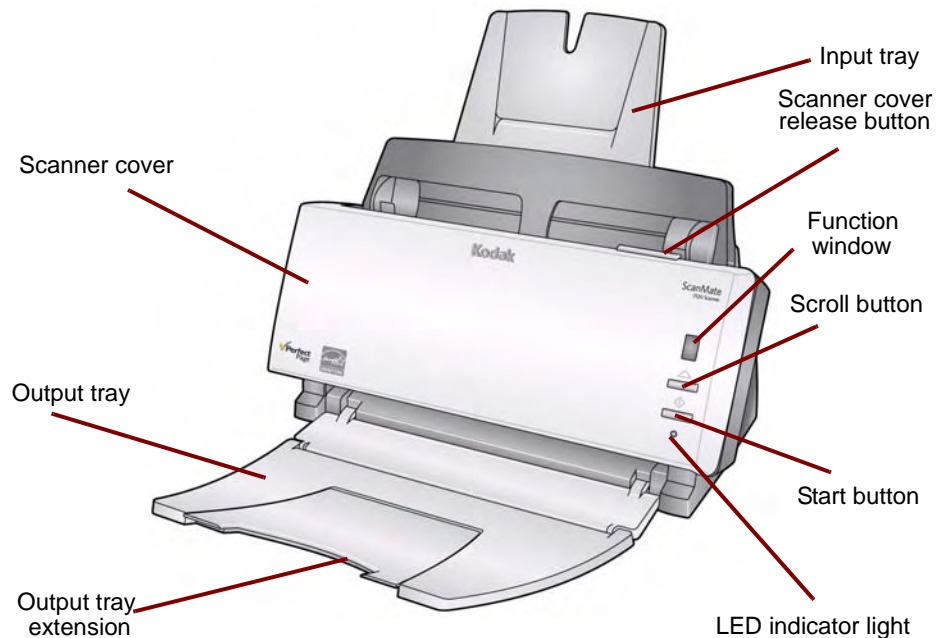

Scanner cover — provides access to the internal components of the scanner.

Output tray — collects the scanned documents.

Output tray extension — unfold this extension when scanning documents longer than 8.5 x 11 inches (A4).

Input tray — holds up to 50 documents in place. Adjusts to fit the document size.

Scanner cover release button — opens the scanner cover for maintenance and clearing documents.

Function window — displays 1 through 9. These numbers correspond to 9 predefined scanning functions. For more information see the *User's Guide for Smart Touch* provided on the Installation CD. The Function window will also display error codes. See Chapter 5, *Troubleshooting* for a listing of these error codes.

Scroll button — allows you to select or scroll through predefined functions 1 through 9.

Start button — launches the selected application that is associated with the number displayed in the Function window.

LED indicator light — illuminates or flashes indicating scanner status.

- **Steady green:** ready to scan
- **Flashing green:** preparing to scan
- **Flashing red:** error indication such as, *Scanner Cover Open*, in conjunction with the Function window displaying an "E". See Chapter 5, *Troubleshooting* for a listing of these error codes.

NOTE: The Start button, Scroll button and Function window are used with Smart Touch functionality.

Back view

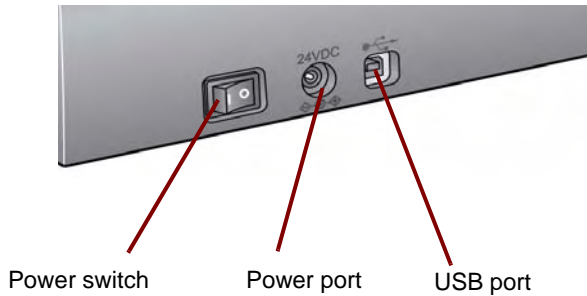

Power switch — turns the scanner on and off.

Power port — connects the power cord to the scanner.

USB port — connects the scanner to the PC.

Inside view

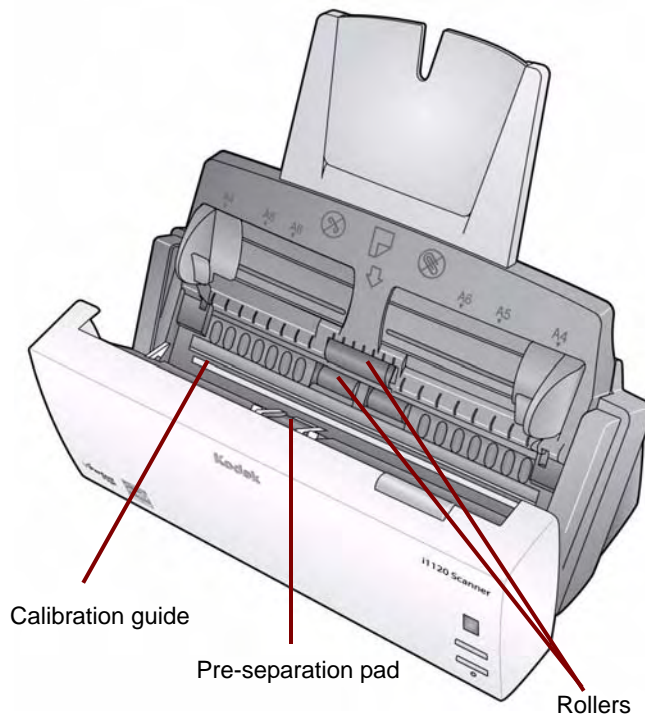

Calibration guide — for optimum image quality, keep the calibration guide clean.

Pre-separation pad and rollers— provides smooth document feeding and separation of various sizes, thicknesses and textures of documents.

2 Installation

Contents

Installing the scanner	2-1
Install the <i>Kodak Driver Software</i>	2-1
Attach the input tray	2-2
Attach the output tray	2-4
Connect the power cord and USB cable.....	2-5
Turning on the scanner	2-6
Turning the scanner off	2-6
Starting the scanner after an automatic power off.....	2-6

Installing the scanner

This section provides detailed information of the *Installation Guide* that is provided with your scanner. Follow these steps in the order they are provided to install your scanner.

NOTES:

- If you have already performed all of the steps in the *Installation Guide*, skip this section.
- **The *Kodak Driver Software* must be performed *first*, before installing any other portions of the scanner.**

Installing the *Kodak Driver Software*

1. Insert the *Kodak ScanMate i1120 Scanner Installation CD* in the CD-ROM drive. The installation program starts automatically.
2. Select **Install Scanner Software**.

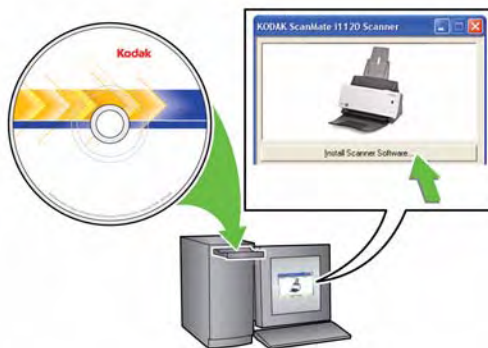

NOTES:

- If the CD does not start automatically, open the My Computer icon on your desktop. Double-click the icon indicating your CD-ROM drive, then double-click on **setup.exe**.
- If the message ***Portions of this application are already installed*** is displayed, click **Yes** to continue the installation process. Any previously installed *Kodak Scanner* software that is shared with this scanner will be updated.

3. Click **Next** when the Welcome screen is displayed.
4. Click **I Agree** after you have read and agreed with the terms of the Software License Agreement. The installation will start and several progress screens will be displayed.
5. Click **Finish** when the installation is complete.
6. Remove the *Kodak ScanMate i1120* Scanner Installation CD from the CD-ROM drive.

Attaching the input tray

1. Press the release button to open the scanner cover.



2. Attach the two input tray pieces by aligning the slots and snapping them together.

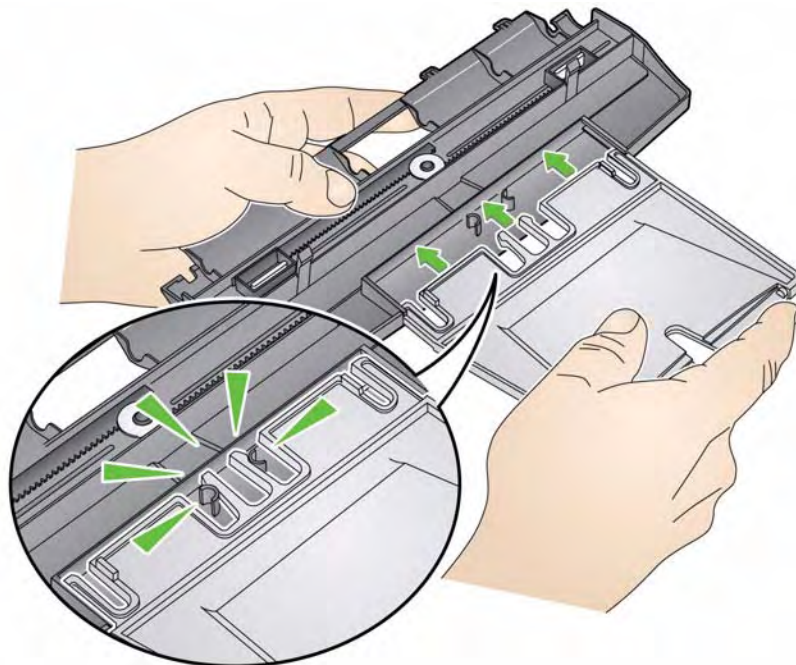

3. Align the four tabs on the input tray with the slots on the scanner.

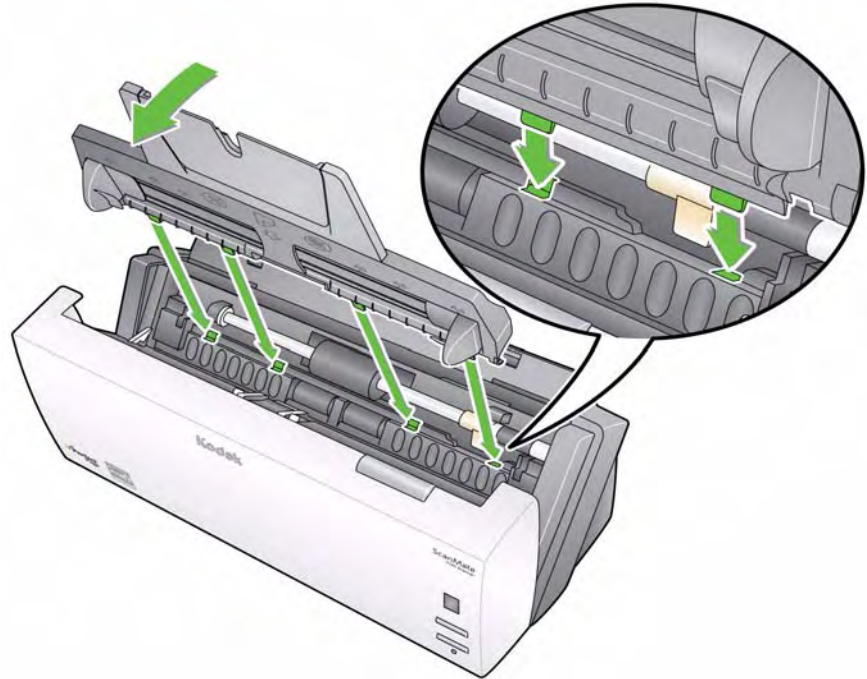

4. Roll the input tray toward the back of the scanner until it snaps into place.

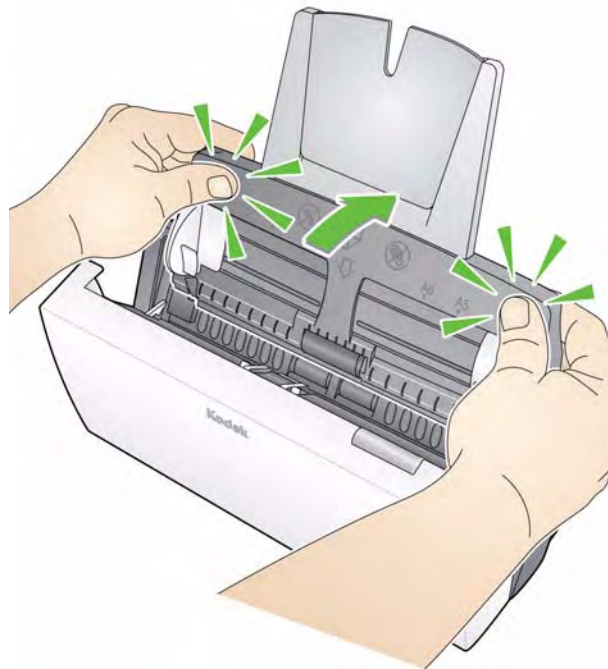

5. Close the scanner cover.

Attaching the output tray

1. Locate the output tray slots on the scanner.
2. Align the output tray pins with the slots and lower the output tray into place.

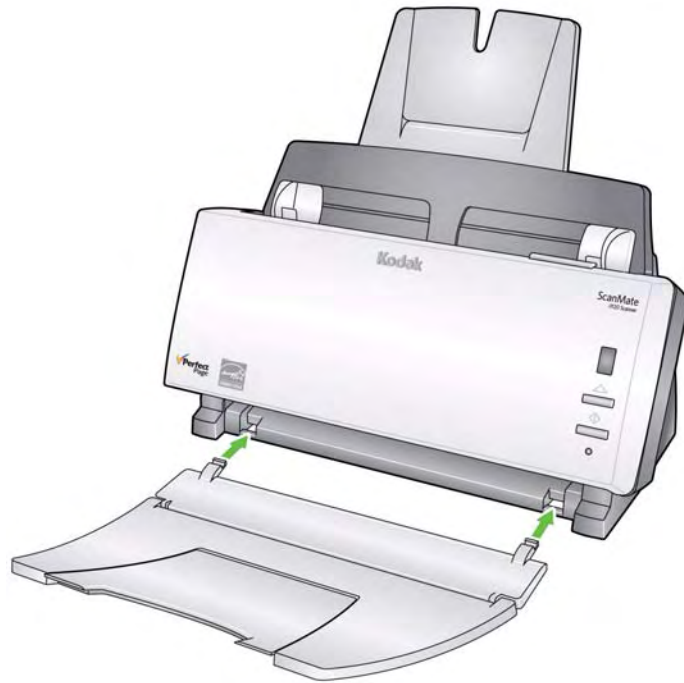

NOTE: The output tray can be folded up when not in use for easy storage.

Connecting the power cord and USB cable

When the drivers have been installed, connect the power supply, power cord and USB cable to the scanner. Refer to the illustration below for making proper connections. Make sure the power outlet is located within 1.52 metres (5 feet) of the scanner and is easily accessible.

1. Select the appropriate AC power cord for your region from the supply of power cords packed with your scanner.
2. Attach the power cord for your power type to the power supply.

NOTE: Be sure that the power cord is securely attached to the power supply.

3. Plug the output power cord from the power supply into the power port on the scanner.
4. Plug the other end of the power cord into the wall outlet.

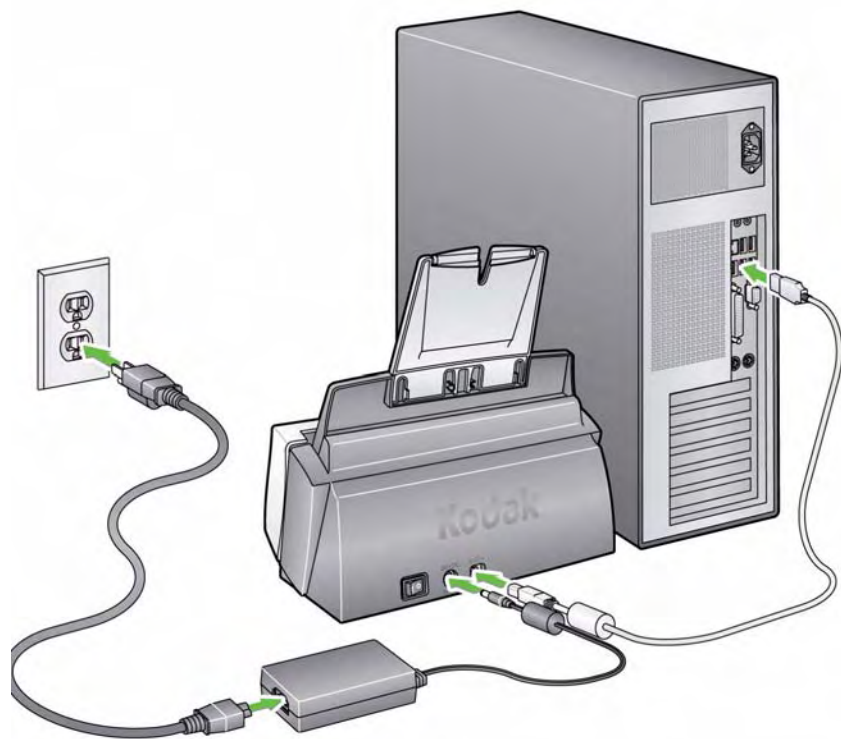

5. Attach the USB cable to the scanner USB port, located on the back of the scanner.
6. Attach the other end of the USB cable to the proper USB port on your PC.

NOTE: If you installed a USB card, use one of those ports, or use your PC's USB port. See your PC manufacturer's documentation for the location of the USB port.

Turning on the scanner

When you turn on the scanner, the green indicator on the front of the scanner will flash as the scanner goes through a series of self tests.



Please wait while the operating system synchronizes the scanner with the installed software.

When the installation process is complete and ready to scan, the green LED indicator light will stop flashing and a number will be displayed in the Function window.

NOTE: If the LED indicator light continues to flash or "E" is displayed in the Function window, refer to Chapter 5, *Troubleshooting*.

Turning the scanner off

To turn the scanner off, press the power button to the Off (O) position.

NOTE: The *Power Off* energy saver feature will turn the scanner off after 60 minutes of inactivity.

Starting the scanner after an automatic power off

If your scanner goes into energy saver mode after 60 minutes of inactivity, just press the Start button to turn the scanner on again.



3 Scanning

Contents

Getting your scanner ready to scan	3-1
Getting your documents ready to scan	3-2
Selecting your scanning application.....	3-3
Scanning with Smart Touch	3-4

Getting your scanner ready to scan

1. Be sure the scanner is on and ready to scan (green indicator light is on and constant).
2. Adjust the side guides (by sliding them in or out) to accommodate the size of documents you are scanning.

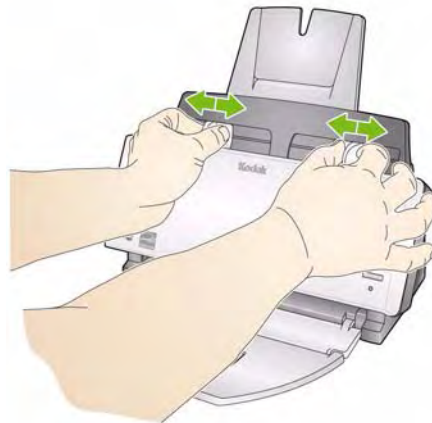

3. If you are scanning documents longer than 8.5 x 11 inches (A4), open the extender on the input and output trays.

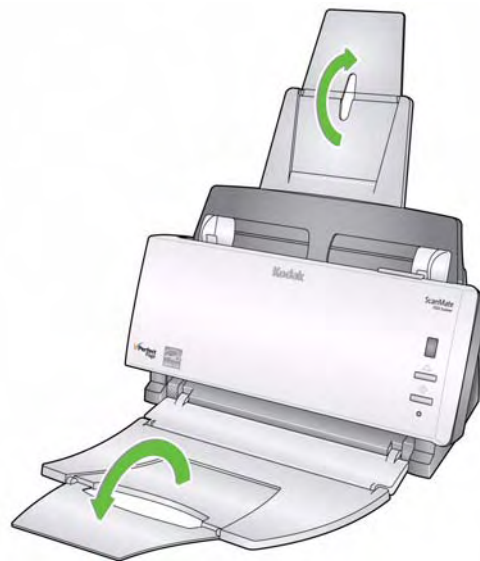

Getting your documents ready to scan

1. Standard paper size documents feed easily through the scanner. When organizing documents for scanning, stack the documents so the lead edges are aligned and centered in the input tray. This allows the feeder to introduce documents into the scanner one at a time.
2. Remove all staples and paper clips before scanning. Staples and paper clips on documents may damage the scanner and documents.
3. All inks and correction fluids on the paper must be dry before scanning is started.
4. Be sure the front side of your document(s) is positioned against the input tray and the top of the document(s) is inserted into the input tray first (see the arrows below).

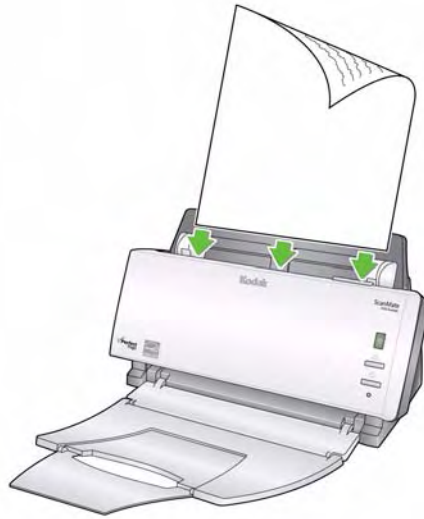

5. Place the documents you want to scan in the input tray of the scanner.

Selecting your scanning application

Smart Touch — Kodak provides Smart Touch functionality which allows you to quickly and easily perform common scanning tasks; such as:

- scan and share incoming client correspondence with a co-worker in a branch office
- create a searchable PDF of a printed report
- scan and print/fax an invoice
- scan a photo to add to a presentation

Nine predefined task shortcuts are available for you to use. You can modify and rename any of the shortcuts to create your own custom tasks. You can also preview and easily edit images (zoom, pan, rotate, crop, and much more) before they are sent to their destination.

ScanSoft PaperPort — use this software to scan your documents into organized files that you can quickly find, use and share. PaperPort provides a unique visual desktop that displays thumbnails of your documents so you can easily browse and locate information fast.

ScanSoft OmniPage — this productivity application delivers accurate document conversion for turning paper and PDF files into electronic files you can edit search and share. Its OCR engines and precise formatting ensure that your electronic documents look exactly like the original - complete with text, graphics, columns and tables.

Presto BizCard 5 — quickly and easily converts the contact information from business cards into a searchable, digital database that can be easily synchronized between PCs, notebooks, PDAs and PIMs.

NOTE: Smart Touch was installed when you installed the *Kodak Driver Software*. The rest of the above scanning applications are provided on separate CDs that were included with your scanner. Refer to the application's User's Guide for instructions on how to install and use it.

Scanning with Smart Touch

The following steps are an example of creating a **Black and White PDF** using Smart Touch. For more information on how to use Smart Touch, see the *User's Guide for Smart Touch* provided on the Installation CD.

1. Press the **Scroll** button until number "6" is displayed in the function window.



2. Press the **Start** button.



The document will be scanned and the resulting image will be placed in the Output folder in the Smart Touch directory under "My Documents".

4 Maintenance

Contents

Cleaning procedures.....	4-1
Cleaning the rollers	4-2
Cleaning the pre-separation pad	4-3
Cleaning the calibration area.....	4-4
Replacement procedures.....	4-4
Replacing the pre-separation pad.....	4-4
Replacing the feed roller assembly	4-6
Supplies and consumables	4-7

Cleaning procedures

Your scanner needs to be cleaned periodically. If your documents do not feed easily, if several documents feed at the same time or if streaks appear on your images, it is time to clean your scanner. The section entitled, “Supplies and consumables” at the end of this chapter provides a listing of the supplies required to clean your scanner.

IMPORTANT: Use only non-flammable cleaners such as those provided through Kodak Parts Services. Do not use household cleaners.

Allow surfaces to cool to ambient temperature before use. Do not use cleaners on hot surfaces.

Use adequate ventilation. Do not use cleaners in confined areas.

- Press the release button to open the scanner cover.

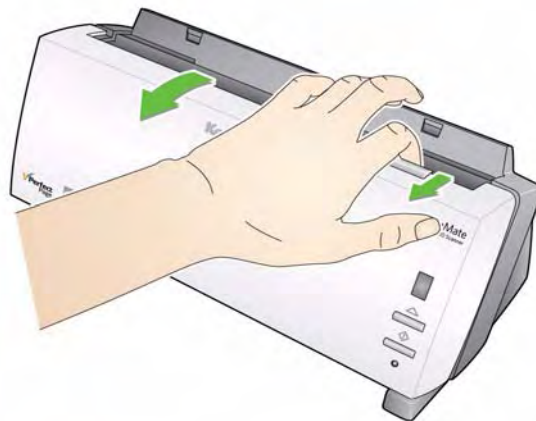

Cleaning the rollers

1. Press the release button to open the scanner cover.
2. With a roller cleaning pad, wipe the feed roller from side to side. Rotate the feed roller to clean the entire surface.

IMPORTANT: The roller cleaning pad contains sodium lauryl ether sulfate which can cause eye irritation. Wash your hands with soap and water after performing maintenance procedures. Refer to the MSDS for more information.

NOTE: For easier cleaning, you can remove the roller. See “Replacing the feed roller assembly” later in this chapter.

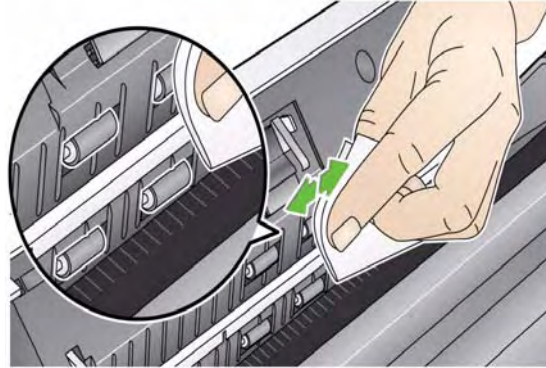

3. Wipe the NFR rollers from side to side. Rotate the NFR rollers to clean the entire surface.

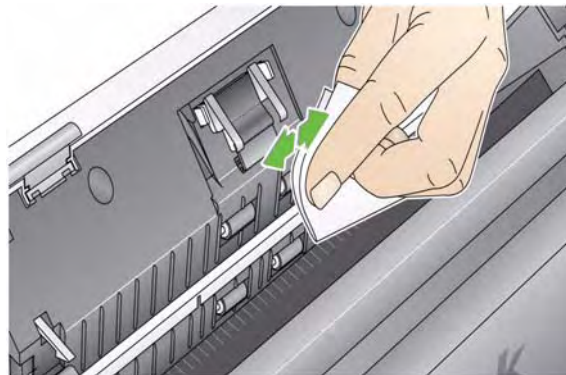

NOTE: For easier cleaning of the NFR rollers, you may want to order *Kodak ScanMate i1120 Scanner Cleaning Swabs*. For ordering information see the section entitled, “Supplies and consumables” later in this chapter. Dry the rollers with a lint-free cloth.

Cleaning the pre-separation pad

1. Press the release button to open the scanner cover.
2. Squeeze the plastic clamps that hold the pre-separation pad in place and lift it out of position.

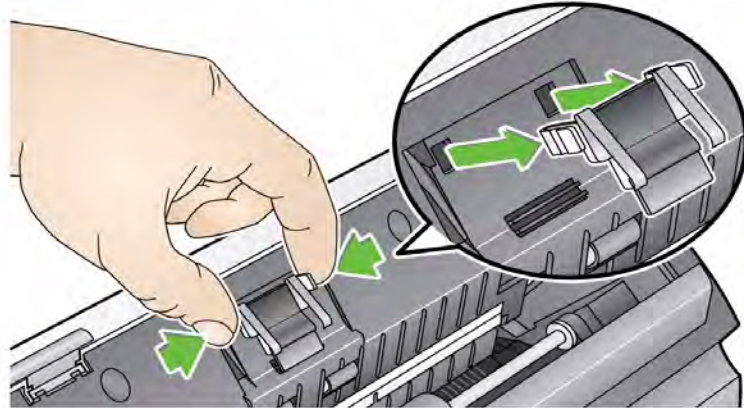

3. Wipe the pre-separation pad from top to bottom with a roller cleaning pad.

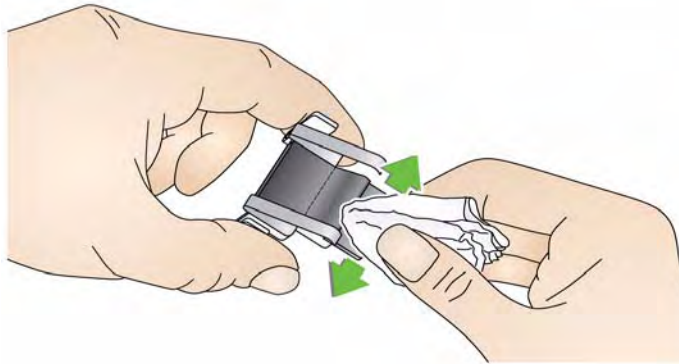

4. Reinsert the pre-separation pad into position, aligning it into the slots, and pushing it in until it snaps into place.

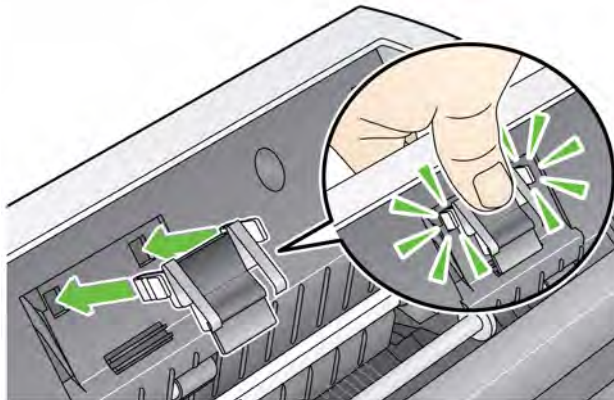

Cleaning the calibration area

1. Press the release button to open the scanner cover.
2. Remove dust and debris from this area by using a Staticide wipe or a small brush. **Be careful not to scratch the glass** (may cause image quality problems) **or bend the white tabs on the front calibration guide** (bending the tabs may cause paper feeding problems) when cleaning the calibration area.

IMPORTANT: Staticide wipes contain isopropanol which can cause eye irritation and dry skin. Wash your hands with soap and water after performing maintenance procedures. Refer to the MSDS for more information.

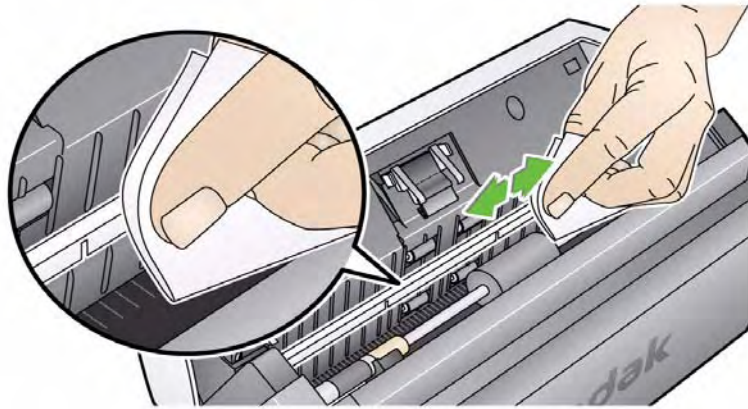

3. Wipe the front and rear calibration guides again with an almost-dry Staticide wipe to remove any streaks.

IMPORTANT: When cleaning the front calibration area, be careful not to bend the white tabs; bending the tabs may cause paper feeding problems.

4. When finished, close the scanner cover.

Replacement procedures

Replacing the pre-separation pad

Degradation of feeder performance, multiple feeds, stoppages, etc. indicate a need to change the pre-separation pad. Certain paper types such as carbonless paper or newsprint, or failure to clean regularly, and/or use of non-recommended cleaning solvents can shorten the pre-separation pad life.

NOTE: Disconnect the electrical power before beginning replacement procedures.

For additional pre-separation pads, see the section entitled, "Supplies and consumables" later in this chapter.

1. Press the release button to open the scanner cover.

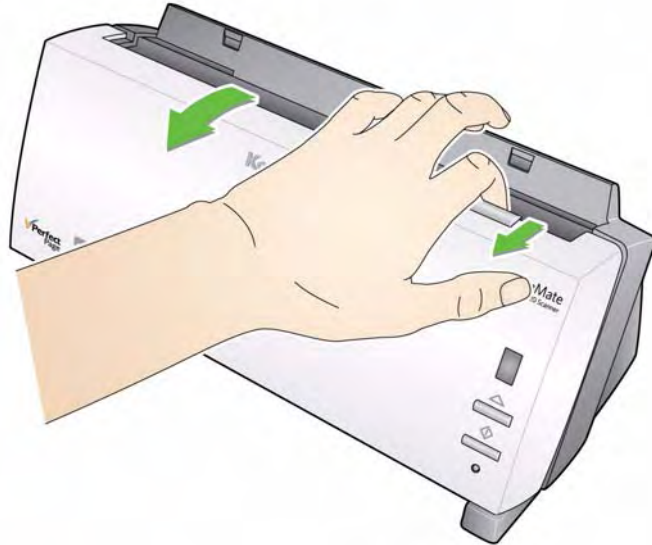

2. Squeeze the plastic clamps that hold the pre-separation pad in place and lift it out of position.

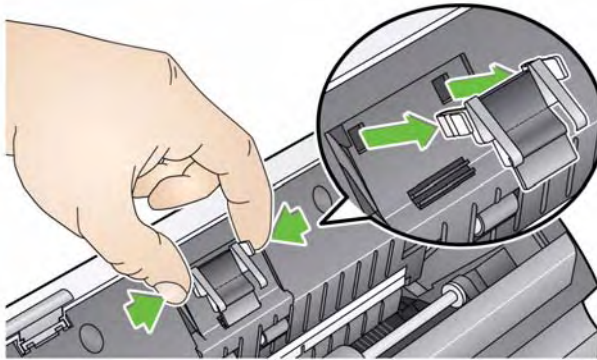

3. Insert the new pre-separation pad into position, aligning it with the slots, and pushing it in until it snaps into place.

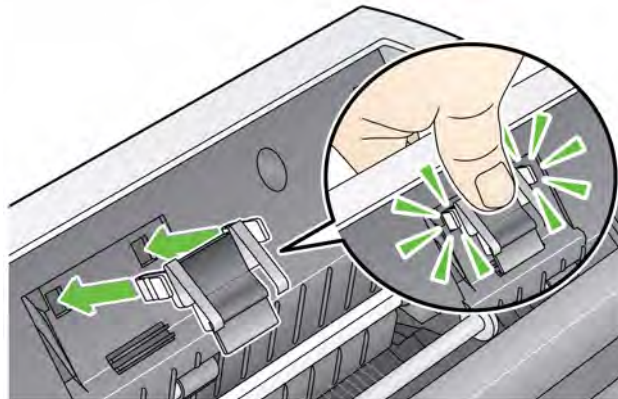

4. Close the scanner cover.

Replacing the feed roller assembly

1. Press the release button to open the scanner cover.
2. Remove the input tray by pulling it forward and lifting it out of position. Set it aside.

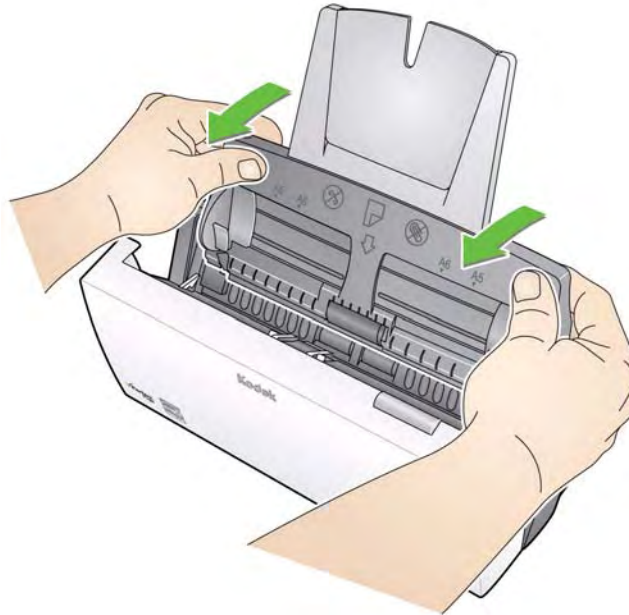

3. Rotate the orange tab upward to release the feed roller assembly and lift the feed roller assembly up and out of the scanner.

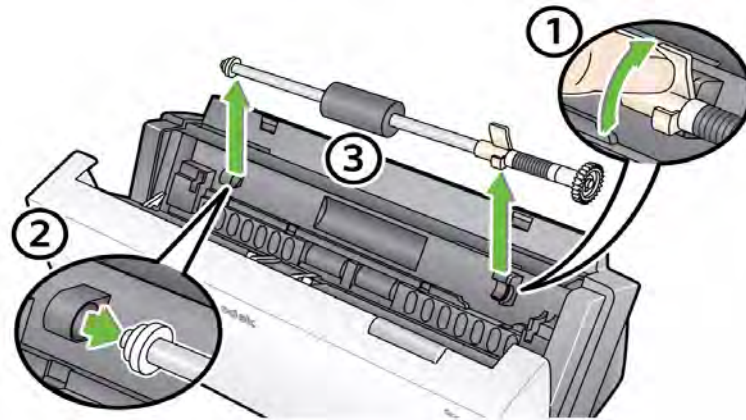

4. Install the new feed roller assembly by aligning the shaft end of the assembly in position.
5. With the orange tab in the upward position, snap the feed roller assembly in place.

- Rotate the orange tab down. If the tab is not in the down position, you will not be able to reinstall the input tray.

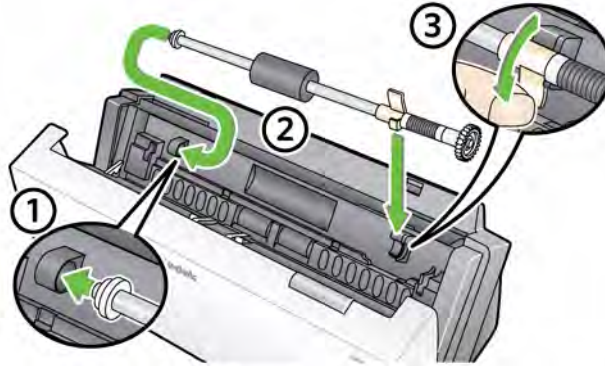

- Reinstall the input tray by locating and aligning the four tabs on the input tray with the slots on the scanner.

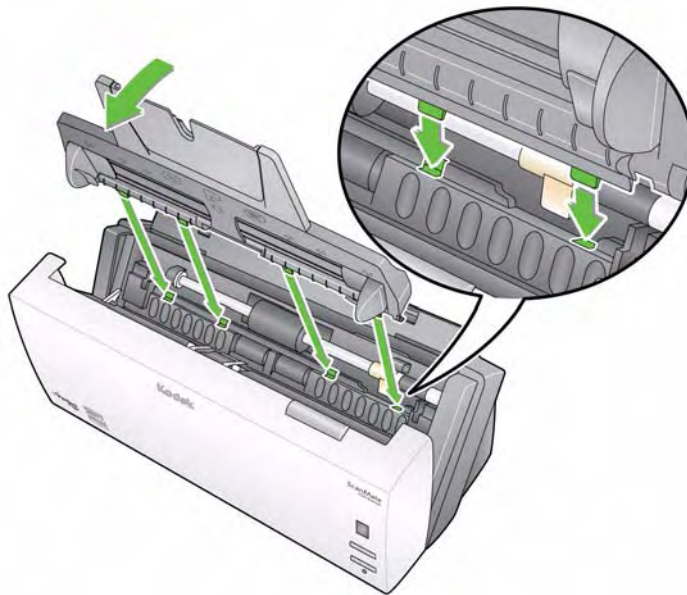

- When tabs and slots are in place, roll the input tray toward the back of the scanner until it snaps into place.

Supplies and consumables

Contact your scanner supplier to order supplies.

Description	CAT No.
<i>Kodak ScanMate i1120</i> Pre-separation pad	894 6097
<i>Kodak ScanMate i1120</i> Feed Roller Assembly	122 6034
<i>Kodak ScanMate i1120</i> Scanner Cleaning Swabs	824 5862
<i>Kodak Digital Science</i> Roller Cleaning Pads	853 5981
<i>Kodak Digital Science</i> Transport Cleaning Sheets (qty 50)	169 0783
Staticide Wipes for <i>Kodak</i> Scanners	896 5519

NOTE: Items and catalog numbers are subject to change.

5 Troubleshooting

Contents

Problem solving 5-1
 LED error codes 5-3
 Contacting Service 5-3

Problem solving

Occasionally you may encounter a situation with your scanner where it may not function properly. Use the chart below as a guide to check possible solutions to help you resolve the situation before calling Technical Support.

Problem	Possible Solution
Scanner automatically shuts off	When you have not used the scanner for 60 minutes, the scanner will automatically shut off. The auto shut-off feature is an energy saving feature of the scanner. To re-enable the scanner, press the power button.
A document is jammed in the scanner	<ul style="list-style-type: none"> • Open the scanner cover. • Remove any jammed document(s) from inside the scanner. • Close the scanner cover and resume scanning.
Scanner will not scan/feed documents	Make sure that: <ul style="list-style-type: none"> • the power cord is plugged securely into the back of scanner and the wall outlet. • the green LED on the scanner is lit. • the power switch is on. • the wall outlet is not defective (call a licensed electrician). • the PC was restarted after installing the software. • document(s) is making contact with the feed rollers.
Image quality is poor or has decreased	Clean the scanner. See the procedures in Chapter 4, <i>Maintenance</i> .
Documents are jamming or multiple documents are feeding	Make sure that: <ul style="list-style-type: none"> • the input tray, output tray and side guides are adjusted for the width and length of the documents you are scanning. • all documents meet the specifications for size, weight and type. See Appendix A, <i>Specifications</i> for more information. • the scanner is clean. • the pre-separation pad is installed properly and securely in place. Replace the pre-separation pad if necessary.
Distorted images	The feeder holds up to 50 documents in the input tray. While scanning is taking place, you cannot add documents to the feeder. If you do add documents, your images may be distorted.
Scanning multiple pages in "Single Page mode"	When scanning multiple pages using Single Page mode, the scanner will pre-feed the next document and the last document scanned will stay in the transport until the next page is scanned. This is a normal scanning process. The document that remains in the transport can be safely pulled out if you want, however, it will automatically be completely fed through the transport and into the output tray when the next page or last page is scanned.

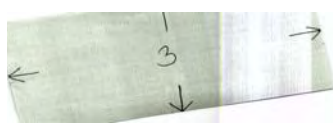
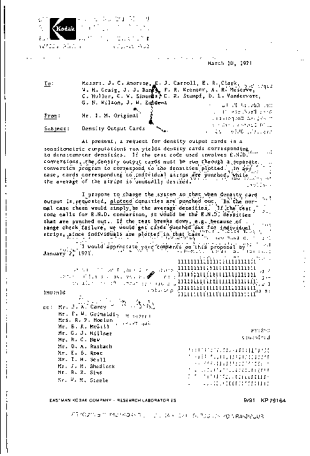
Problem	Possible Solution
No images are being displayed	<ul style="list-style-type: none"> • Documents should only be inserted in the feeder after the scanner is powered up and ready. • If you are scanning one side of a document, be sure the side you want to scan is placed toward the feed tray (not facing you). For more information, see the section entitled, "Getting your documents ready to scan" in Chapter 3.
Image has clipped corners 	If your images have clipped corners, the skew angle was too large for the scanner to handle. Be sure documents are placed in the input tray with the edges aligned and the side guides positioned correctly to accommodate the size documents you are feeding to avoid large skew angles.
First image in a batch appears "washed out" 	If the scanned documents in a batch have more than a 25 degree skew, the first image in the batch may appear washed out. Be sure that documents are placed in the input tray with the edges aligned and the side guides positioned correctly to accommodate the size documents you are feeding to avoid large skew angles.
Image appears to be cut off	<p>If you are scanning a document with a reflective area (such as a hologram), and this reflective area is fed "face up" and off-center such that it passes over the left-edge sensor, the sensor will be triggered as if it were the end of the page and will result in a cut-off image.</p> <ul style="list-style-type: none"> • Rescan the document by feeding it face down.
Images are not cropped correctly	<ul style="list-style-type: none"> • If auto or aggressive cropping is enabled, and your images are not cropped correctly, clean the white background strips in the calibration area. See the procedures in Chapter 4, <i>Maintenance</i> "Cleaning the calibration area".
Roller marks appear on the document after scanning	Clean the rollers. See the procedures in Chapter 4, <i>Maintenance</i> .
Images have black background bleed-through 	When scanning translucent documents, black bleed-through may be displayed on the image. To minimize this, adjust the Contrast value or select Fixed Processing to improve the image. For more information on Contrast and Fixed Processing, see the <i>Scanning Setup Guide</i> on the Installation CD.
Scanner is running slow	<ul style="list-style-type: none"> • Your PC may not meet the minimum requirements for the scanner. • The scanner is rated and designed to operate with USB 2.0, but will function with USB 1.1. If you are using a USB 1.1 connection, update your connection to USB 2.0.
Cannot scan after Standby or Hibernate with Microsoft Windows Vista	Upgrade to Service Pack 1 or higher.

LED error codes

Following is a listing of the error codes that may be displayed in the Function window. When an error occurs, the red indicator will blink and a number is displayed in the Function window.

Code	Problem	Remedy
E 1 E 2 E 3 E 4	Scanner failure	Turn the scanner off, then on again. restart the scanning application and try again. If the problem persists, contact Kodak Service.
E 5	Internal test	
E 6	Light check failure	
E 7	Command failure	
E 8	Document jam	Open the scanner cover and remove any paper in the paper path.
E 9 E 0	Internal test	Turn the scanner off, then on again. Restart the scanning application and try again. If the problem persists, contact Kodak Service.
E 1 5	Scanner cover open	Close the scanner cover.

Contacting Service

1. Visit www.Kodak.com/go/disupport to obtain the current phone number for your country.
2. When calling, please have the following information ready:
 - A description of your problem.
 - The scanner model and serial number.
 - Computer configuration.
 - Software application you are using.

Appendix A Specifications

This appendix provides scanner specifications and system requirements.

Scanner Type/Speed	Duplex color scanner with an automatic document feeder, scans 20 pages per minute (landscape)
Scanning Technology	CCD type, 600 dpi optical resolution Grayscale output bit depth is: 8 Color capture bit depth is: 24 Color output bit depth is: 24
Output Resolutions	75, 100, 150, 200, 240, 300, 400, 600 and 1200 dpi
File Format Output	BMP, TIFF, JPEG, PDF (with bundled software)
Acceptable Paper Weight	7.3 to 12.7 kg (16 to 28 lbs.)
Maximum document size	21.6 x 86.36 cm (8.5 x 34 in.)
Minimum document size	6.35 x 5 cm (2.5 x 2 in.)
ADF Capacity	50 sheets
Recommended Daily Volume	500
Illumination	Fluorescent
Electrical requirements	100 - 240 V (international), 50/60 Hz Adapter: Hitron / HEG42-240200-7L: 24Vdc, 2.0 A
Scanner Dimensions	Height: 14 cm / 5.5 in. (not including input tray) Width: 29.8 cm / 11.75 in. (not including input and output trays) Depth: 15.9 cm / 6.25 in.
Scanner Weight	2.6 kg / 5.72 lbs.
Host Connection	USB 2.0
Operating Temperature	10°C to 35°C
Humidity	10 to 85%
Environmental Factors	Energy Star qualified scanners
Power Consumption	Off mode: <25 watts Running: <40 watts Energy Star: <7
Acoustic Noise (Sound Power level)	Operating: less than 58 dB Off mode: less than 46 dB
Bundled software	Nuance ScanSoft PaperPort Nuance ScanSoft OmniPage NewSoft BizCard

System requirements

Following is the minimum recommended system configuration to run a *Kodak ScanMate i1120 Scanner*.

- Recommended processor and memory:
Intel® Core™ 2 @ Duo 2.66 GHz or equivalent, 4GB RAM
- USB port 2.0 (compatible with USB 1.1 but at slower speeds)
- 200 MB free hard disk space
- Supported operating systems:
 - Microsoft Windows Vista (32-bit and 64-bit); SP1 recommended
 - Microsoft Windows XP Pro SP2/SP3 (32-bit)
 - Microsoft Windows XP x64 Edition SP2
 - Microsoft Windows 2003 Server R2 x64 Edition (TWAIN only)
 - Microsoft Windows 7 SP1 (32-bit and 64-bit)
 - Microsoft Windows 8 (32-bit and 64-bit)
 - Linux Ubuntu 12.04

Included Drivers:

- Windows operating systems: TWAIN, ISIS, WIA

Appendix B Warranty - US and Canada only

Congratulations on the purchase of a *Kodak* Scanner. *Kodak* Scanners are designed to provide end users with the highest performance and reliability. All *Kodak* Scanners are covered by the following Limited Warranty.

Limited warranty for *Kodak* Scanners

Eastman Kodak Company provides the following Limited Warranty on *Kodak* Scanners (excluding spare parts and consumables) distributed by Kodak or through Kodak's authorized distribution channels:

Kodak warrants that a *Kodak* Scanner, from the time of sale through the Limited Warranty period applicable to the Product, will be free of defects in materials or workmanship and will conform to the performance specifications applicable for the particular *Kodak* Scanner.

All *Kodak* Scanners are subject to the Warranty Exclusions described below. A *Kodak* Scanner found to be defective or which does not conform to the product specifications will be repaired or replaced with new or refurbished product at Kodak's option.

Purchasers may determine the applicable Limited Warranty period for the *Kodak* Scanners purchased by calling (800) 822-1414, or by visiting www.Kodak.com/go/disupport or by reviewing the Limited Warranty Summary Card enclosed with the *Kodak* Scanner.

Proof of purchase is required to demonstrate eligibility for warranty service.

Warranty exclusions

Kodak's Limited Warranty does not apply to a *Kodak* Scanner that has been subjected to physical damage after purchase, caused, for example, by casualty, accident, acts of God or transportation, including (a) by a failure to properly package and ship the Scanner back to Kodak for warranty service in accordance with Kodak's then current Packaging and Shipping Guidelines, including failure to replace the shipping restraint prior to shipping, or by a failure to remove the shipping restraint prior to use; (b) resulting from the user's installation, system integration, programming, re-installation of user operating systems or applications software, systems engineering, relocation, reconstruction of data, or removal of the product or any component (including breakage of a connector, cover, glass, pins, or seal); (c) from service, modification or repair not performed by Kodak or a service provider authorized by Kodak or by tampering, use of counterfeit or other non-Kodak components, assemblies, accessories, or modules; (d) by misuse, unreasonable handling or maintenance, mistreatment, operator error, failure to provide proper supervision or maintenance, including use of cleaning products or other accessories not approved by Kodak or use in contravention of recommended procedures or specifications; (e) by environmental conditions (such as excessive heat or other unsuitable physical operating environment), corrosion, staining, electrical work external to the product or failure to provide electro-static discharge (ESD) protection; (f) by failure to install firmware updates or releases available for the product and (g) by such other supplemental exclusions published from time to time online at www.Kodak.com/go/disupport or by calling (800) 822-1414.

Kodak provides no Limited Warranty for products purchased from countries other than the United States. Purchasers of products from foreign distribution channels must seek warranty coverage, if any, through the original source of purchase.

Kodak provides no Limited Warranty for products that are purchased as part of a third party manufacturer's product, computer system or other electronic device.

Any warranty for these products is provided by the OEM (Original Equipment Manufacturer) as part of that manufacturer's product or system.

The replacement product assumes the remainder of the Limited Warranty period applicable to the defective product or thirty (30) days, whichever is longer.

Installation Warning and Disclaimer

KODAK WILL NOT BE RESPONSIBLE FOR ANY CONSEQUENTIAL OR INCIDENTAL DAMAGES RESULTING FROM THE SALE, INSTALLATION, USE, SERVICING OR IMPROPER FUNCTIONING OF THIS PRODUCT, REGARDLESS OF THE CAUSE. SUCH DAMAGES FOR WHICH KODAK WILL NOT BE RESPONSIBLE, INCLUDE, BUT ARE NOT LIMITED TO, LOSS OF REVENUE OR PROFIT, LOSS OF DATA, DOWNTIME COSTS, LOSS OF USE OF THE PRODUCT, COST OF ANY SUBSTITUTE PRODUCT, FACILITIES OR SERVICES OR CLAIMS OF CUSTOMERS FOR SUCH DAMAGES.

If there is any conflict between other sections of this appendix and the Limited Warranty, the terms of the Limited Warranty prevail.

How to obtain limited warranty service

Kodak Scanners are supplied with information on unpacking, setup, installation and operation. Careful reading of the User's Guide will answer most of the technical questions the end user might have regarding proper installation, operation and maintenance of the product. However, should additional technical support be required, you may visit our website at: www.Kodak.com/go/disupport or contact:

Kodak's Response Center: (800) 822-1414

The Response Center is available Monday – Friday (excluding *Kodak* holidays) 8 a.m. to 5 p.m. EST.

Before placing the call, the eligible purchaser should have the *Kodak* Scanner model number, part number, serial number and proof of purchase available. The eligible purchaser should also be prepared to provide a description of the problem.

Response Center personnel will assist the end user in resolving the problem over the phone. The end user may be asked to run some simple, self-diagnostic tests and report the resulting status and error code messages. This will assist the Response Center in determining if the problem is the *Kodak* Scanner or another component and if the problem can be resolved over the phone. If the Response Center determines a hardware problem exists that is covered either under the Limited Warranty or a purchased Maintenance Agreement, a Return Material Authorization Number (RMA) will be assigned as needed, a service request will be initiated and repair or replacement procedures will follow.

Packaging and shipping guidelines

Purchaser must ship all warranty returns in a method that guarantees full protection of the product from shipping damage. Failure to do so will void the *Kodak* Scanner warranty. *Kodak* advises the purchaser to keep the original box and packing materials for storing or shipping. *Kodak* is not responsible for issues related to shipping damage. The purchaser must return only the *Kodak* Scanner. Prior to shipment, purchaser must remove and retain all "add-on" items, (i.e. adapters, cables, software, manuals, etc.). *Kodak* accepts no responsibility for these items and they will not be returned with the repaired or replacement *Kodak* Scanner. All products should be returned to *Kodak* in the original shipping container, or an authorized packaging box for the units being returned. Purchaser must install the shipping restraint before the *Kodak* Scanner is shipped. When the original packaging is not available, contact *Kodak*'s Response Center at (800) 822-1414 for part numbers and replacement packaging ordering information.

Return procedure

Eligible purchasers seeking services for *Kodak* Scanners covered under this Limited Warranty must obtain a Return Material Authorization number ("RMA") by calling (800) 822-1414 and within ten (10) business days from the date of issuance of the RMA must return the *Kodak* Scanner to the address designated in the RMA at the end user's own expense and risk, in compliance with *Kodak*'s current Packaging and Shipping Guidelines.

Any defective products or parts replaced by *Kodak* become the property of *Kodak*.

Customer responsibility

BY REQUESTING SERVICE, THE ELIGIBLE PURCHASER ACKNOWLEDGES THE TERMS OF THE LIMITED WARRANTY, INCLUDING THE DISCLAIMER AND LIMITATION OF LIABILITY PROVISIONS. PRIOR TO SEEKING SERVICE, THE END USER MUST BACK-UP ANY DATA OR FILES THAT MAY BECOME DAMAGED OR LOST. *KODAK* IS, WITHOUT LIMITATION, NOT RESPONSIBLE FOR LOST OR DAMAGED DATA OR FILES.

Warranty Service descriptions

Eastman *Kodak* Company (*Kodak*) offers a range of service programs to support its Limited Warranty and to assist with the use and care of the *Kodak* Scanner ("Service Methods"). A *Kodak* Scanner represents an important investment. *Kodak* Scanners provide the productivity needed to stay competitive. The sudden loss of this productivity, even temporarily, could seriously affect the ability to meet commitments. Downtime can be very expensive, not just in the cost of the repair but also in time lost. To help alleviate these problems, *Kodak* may use one of the service methods listed below, depending upon product type, in providing service under its Limited Warranty.

Included with selected *Kodak* Scanners is a Limited Warranty Registration card and a Limited Warranty Summary card. The Limited Warranty Summary card is specific by model. The Limited Warranty Summary card contains important warranty information, including the model number and the Limited Warranty. Refer to the Limited Warranty Summary card to determine the available Service Methods applicable to the particular *Kodak* Scanner.

If the Limited Warranty Registration card or Limited Warranty Summary card cannot be located, additional information may be obtained about the product, including updated warranty and service program information and restrictions, online at www.Kodak.com/go/disupport or by phone at (800) 822-1414.

To avoid service delays, *Kodak* urges end users to complete and return the enclosed Limited Warranty Registration Card at the first opportunity. If you cannot locate the Limited Warranty Registration card, you may register online at www.Kodak.com/go/disupport or by phone at (800) 822-1414.

Kodak also provides a variety of service programs that may be purchased to assist with the use and care of the *Kodak* Scanner. *Kodak* is committed to providing its customers with quality, performance, reliability and service under the Limited Warranty.

On-site service

For the selected *Kodak* Scanner, and after the Response Center verifies a hardware problem, a service call will be opened and logged. An *Kodak* Field Engineer will be dispatched to the product location to perform repair service if the product is located within the contiguous forty-eight (48) United States, in certain areas of Alaska and Hawaii, and if there are no security, safety or physical requirements that would restrict the Field Engineer's access to the scanner. For additional information on service areas, please visit our website at: www.Kodak.com/go/docimaging. On-Site Service will be provided between the hours of 8 a.m. and 5 p.m. local time, Monday through Friday (excluding *Kodak* holidays).

AUR

AUR may be one of the easiest and most comprehensive service offerings in the industry. In the unlikely event of a product defect, for eligible purchasers of certain *Kodak* Scanners, *Kodak* will replace that product within two business days.

The AUR provides advance replacement on specific failed or broken *Kodak* Scanner. To be eligible to take advantage of the AUR, the eligible purchaser must obtain an RMA number, sign an Advance Replacement Agreement and provide a credit card deposit to secure the replacement product. The RMA number should be kept in the event that the status of the replacement product needs to be checked. The eligible purchaser will be asked for the address where the replacement product is to be shipped. The eligible purchaser will also be faxed packing and shipping instructions for the malfunctioning product. The eligible purchaser will then receive a replacement product within 2 business days after the service call initiation and *Kodak*'s receipt of the signed agreement. The malfunctioning product must be received by *Kodak* within ten (10) days of the end user's receipt of the replacement product or the end user's credit card will be charged the list price of the replacement product. Shipment of replacement Imaging Product will be made at *Kodak*'s expense and choice of freight carrier. Shipments not made under *Kodak*'s directions and choice of freight carrier may void the Limited Warranty.

Before the product is returned to *Kodak*, be sure to remove all options and accessories (which include power cord, documentation, etc.) that are not covered by the Limited Warranty. The box and packaging in which the replacement product was shipped must be used to return the malfunctioning product. If the malfunctioning product is not returned in the box and packaging in which the replacement product was shipped the Limited Warranty may be voided. The Return Material Authorization Number ("RMA") must be clearly marked on the outside of the box to ensure proper receipt and credit of the defective product.

Depot service

If the *Kodak* Scanner is not eligible for Advance Exchange or On-Site Service, an eligible purchaser may utilize our Depot Repair Service. The eligible purchaser will be instructed to ship the product to the nearest authorized Depot Repair Center. Product must be shipped at the eligible purchaser's risk and expense to the repair center. Before the product is returned to the repair center, be sure to remove all options and accessories (which include power cord, documentation, etc.) not covered by the Limited Warranty. All products should be returned to *Kodak* in the original shipping container, or in a recommended packing box. The *Kodak* Scanner must have the shipping restraint installed before it is shipped. When the original packaging is not available, contact *Kodak*'s Response Center at (800) 822-1414, for ordering information. Eligible purchasers seeking services for *Kodak* Scanners must obtain a Return Material Authorization number ("RMA") by calling (800) 822-1414, and within ten (10) business days from the date of issuance of the RMA must return the *Kodak* Scanner to the address designated in the RMA at the end user's own expense and risk. The Return Material Authorization Number ("RMA") must be clearly marked on the outside of the box to ensure proper receipt and credit of the defective product.

Upon receipt of the product, the repair center will repair product within ten (10) business days. The repaired product will be shipped back two-day express mail at no expense to the eligible purchaser.

Important restrictions

Eligibility: The Advance Exchange Program and the Depot Service are available to eligible purchasers in the fifty (50) United States, and On-Site Service is available in the contiguous forty-eight (48) states and in certain areas of Alaska and Hawaii for products purchased from authorized distributors of *Kodak*. The *Kodak* Scanner will be ineligible for any service under warranty if the product falls under any of *Kodak*'s then-current Warranty Exclusions, including a purchaser's failure to return defective products to *Kodak* in compliance with *Kodak*'s then current Packaging and Shipping Guidelines. Persons are only considered "eligible purchasers" or "end users" if they originally purchased the *Kodak* Scanner for their own personal or business use, and not for resale.

Consumables: Consumables are items that wear out under normal use and must be replaced by the end user as needed. Consumables, supplies, other expendable items and those items identified as being the user's responsibility in the User's Guide are not covered under the Limited Warranty.

If any of the above excluded parts or services are required, they may be available through an authorized service provider at their hourly rates and at terms then in effect.

Any defective products or parts replaced by *Kodak* become the property of *Kodak*.

Contacting Kodak

- For Information on *Kodak* Scanners: **www.Kodak.com/go/docimaging**
- For U.S. Service, Repair and Technical Assistance by Telephone: **5 a.m. to 5 p.m. Monday-Friday; (800) 822-1414**
(excluding Kodak holidays)
- For Technical Documentation and FAQ's available 24 hours a day: **www.Kodak.com/go/disupport**

Kodak

Eastman Kodak Company
343 State Street
Rochester, NY 14650 U.S.A.
© Kodak, 2013. All rights reserved.
TM: Kodak, ScanMate