



LEICA S

Quickstart guide

TABLE OF CONTENTS

CHARGE BATTERY	04
INSERT BATTERY	04
INSERT MEMORY CARD	05
MOUNT & UNMOUNT LENS	05
OPERATION ELEMENTS	06
INTERFACES	07
BOTTOM VIEW	07
VIEWFINDER	08
STATUS SCREEN	09
TOP DISPLAY	10
SWITCH ON CAMERA	11
TAKING PHOTOS	11
ENTER STATUS SCREEN & PLAY MODE	12
ENTER MENU & PLAY MODE	12
MENU	13
MENU - QUICK ACCESS	14
BASIC CAMERA SETUP	15
PLAYMODE - BROWSE	17
PLAYMODE - ZOOM	18
PLAYMODE - SCREENS	19
PLAYMODE - QUICK 100% ZOOM	20
EXPOSURE MODE M, T	21
EXPOSURE MODE A, P	22
B - BULB MODE / BULB PRESET	23
TETHERED SHOOTING - ADOBE™ PHOTOSHOP™ LIGHTROOM™ WORKFLOW	24
TETHERED SHOOTING - LEICA IMAGE SHUTTLE™ WORKFLOW	26
MENU LIST	27

CHARGE BATTERY

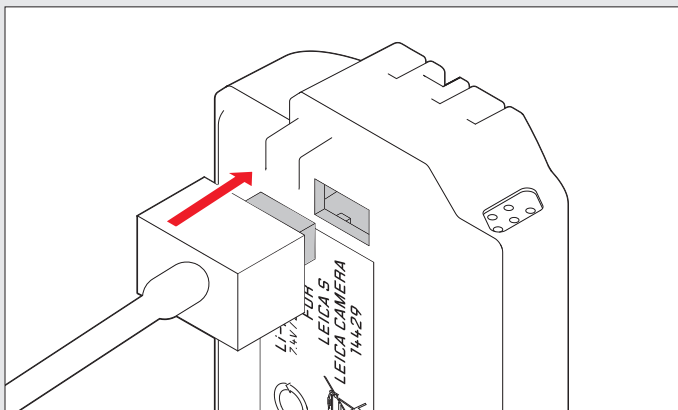

INSERT BATTERY

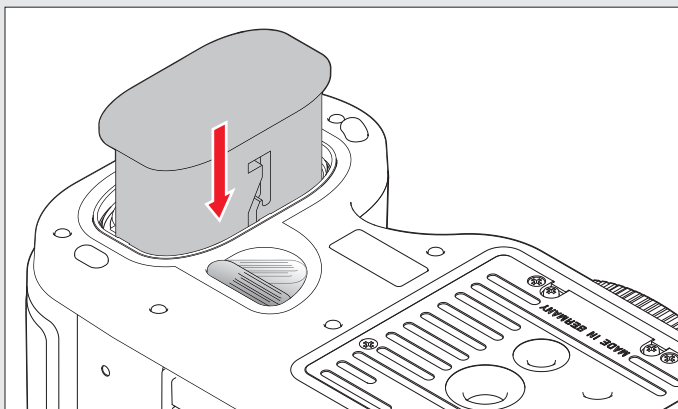

INSERT MEMORY CARD

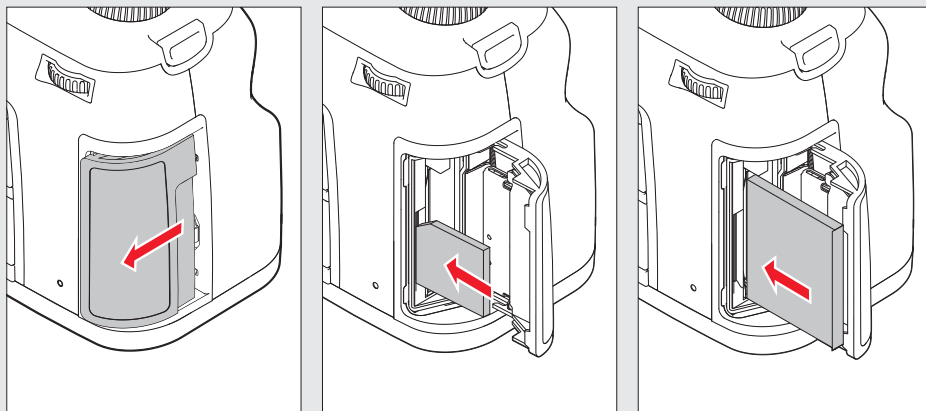

MOUNT & UNMOUNT LENS

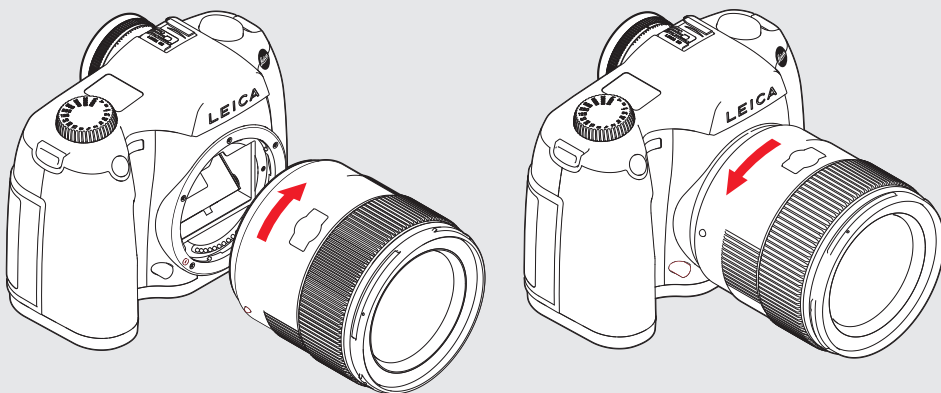

OPERATION ELEMENTS

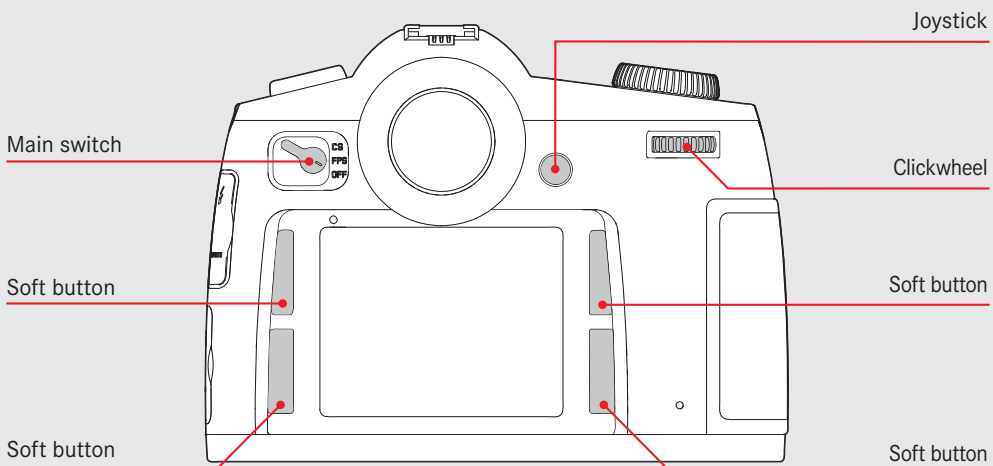
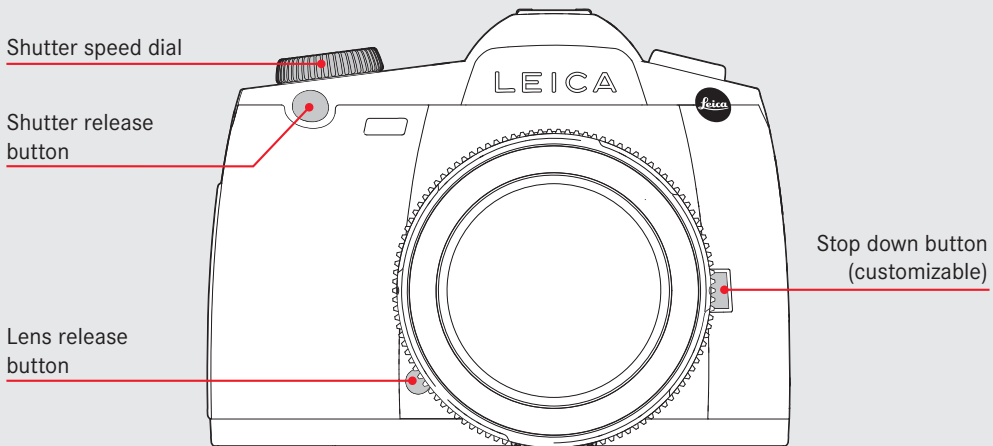

INTERFACES

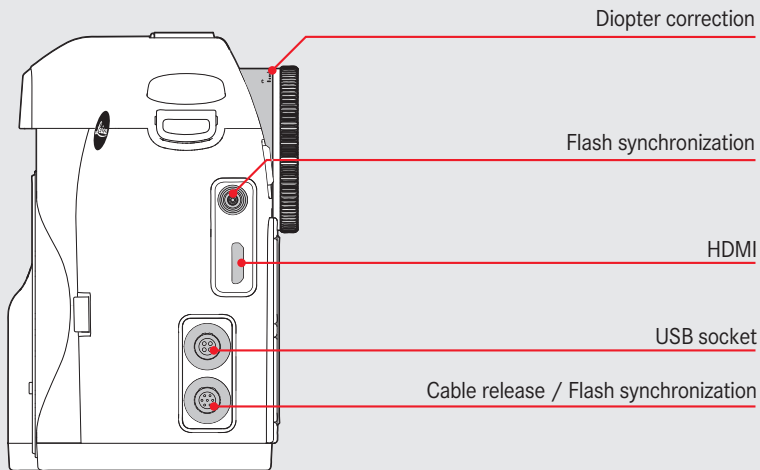

BOTTOM VIEW

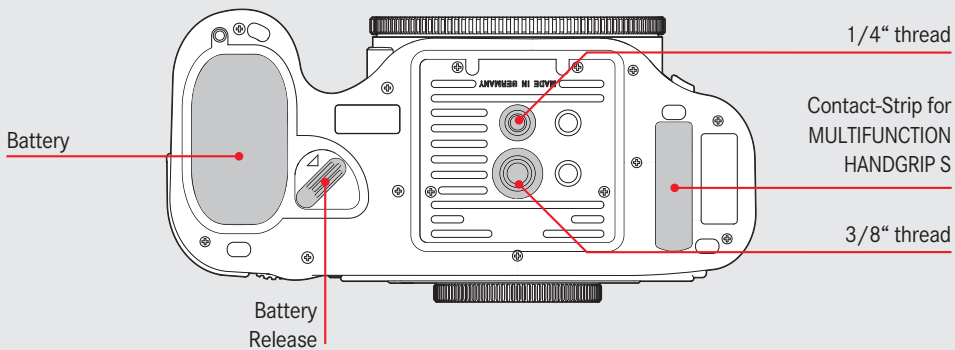

VIEWFINDER

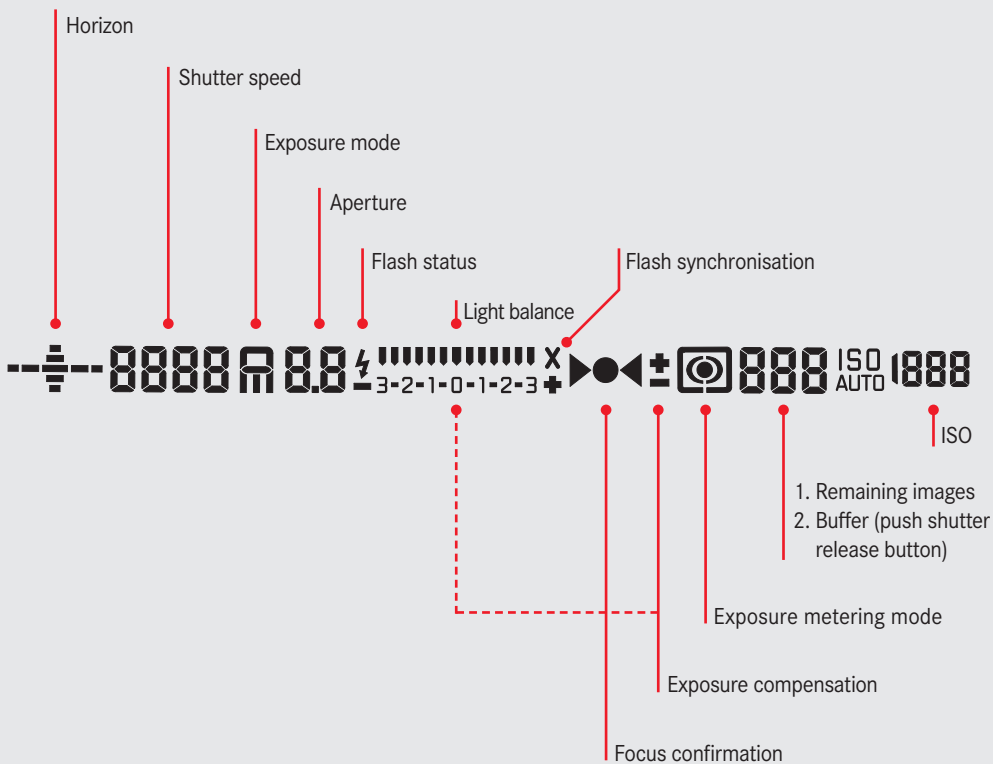

Exposure mode:

P : Automatic program
: Aperture priority

T : Shutter speed priority
m : Manual exposure

Exp. Metering Mode:

 : Multi-field
 : Center-weighted

 : Spot

STATUS SCREEN

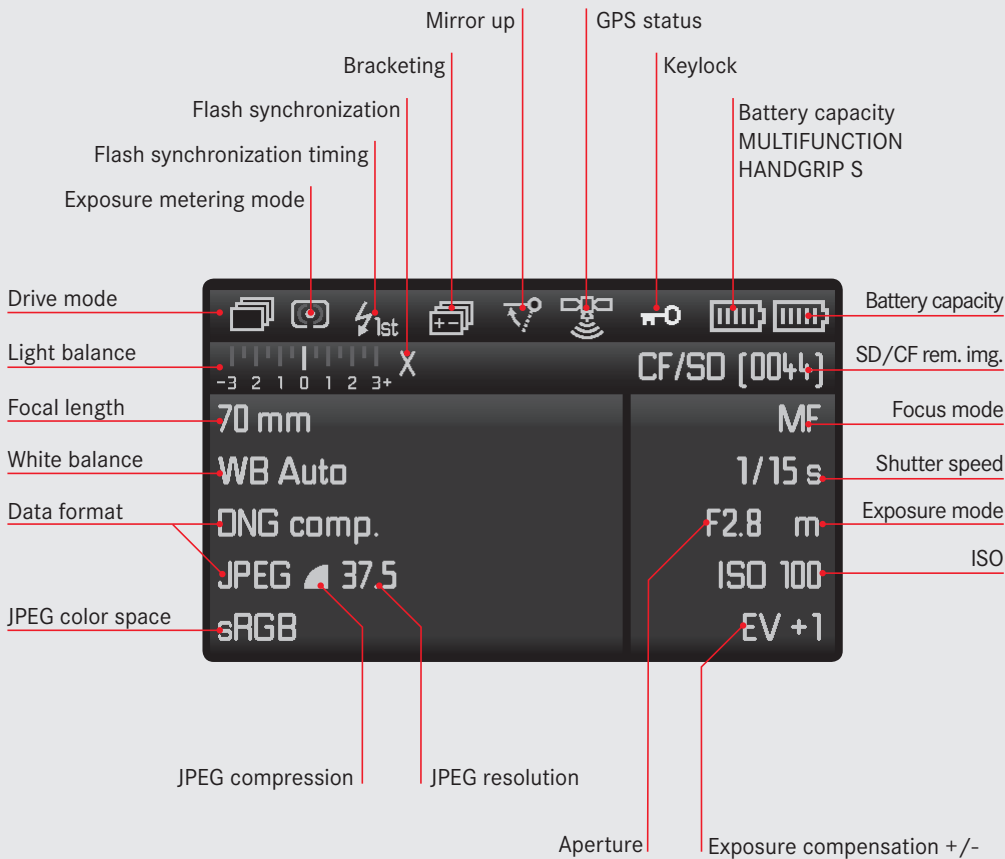

DNG comp. : DNG Compression

: GPS switched on

WB Auto : White Balance

: GPS low signal

: Drive Mode - Single

: GPS switched off

: Drive Mode - Continuous

: Drive Mode - Selftimer

TOP DISPLAY

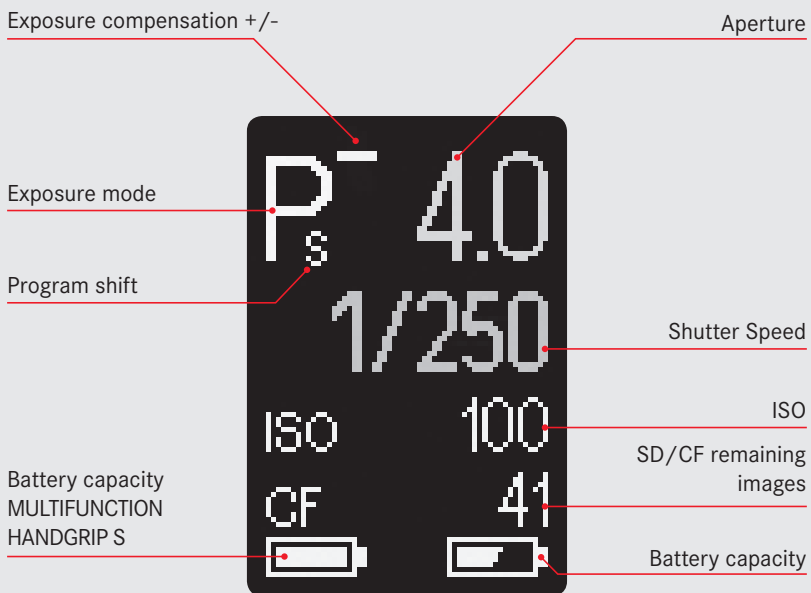
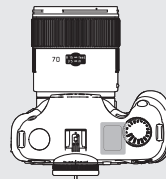

SWITCH ON CAMERA

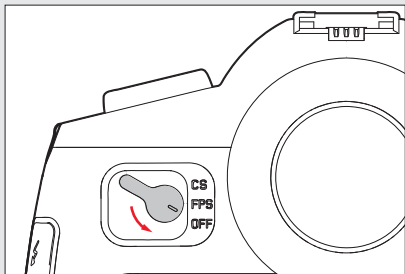
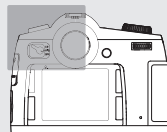

Main switch		Shutter speed	Flash sync	Flash 
FPS	Focal plane shutter	125s to 1/4000s	up to 1/125s	1/125s
CS	Central shutter	8s to 1/1000s	up to 1/1000s	1/1000s

TIP

After booting, the camera will be in Record Mode. Most sequences of this Quick Start Guide will begin in this state.

TAKING PHOTOS

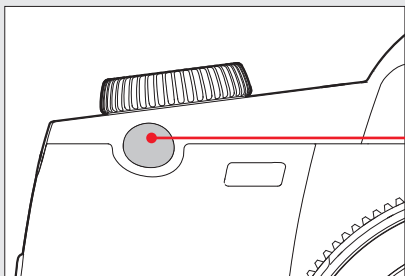

Three Way Shutter Release

1. Stop: AF lock / AE activation
2. Stop: AE lock
3. Stop: Release Shutter

TIP

Press the shutter release button halfway to exit menus and return to Record mode.

ENTER STATUS SCREEN & PLAY MODE

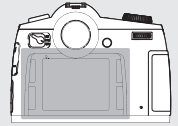

Status Screen

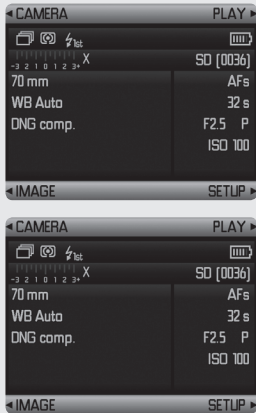

Status Screen

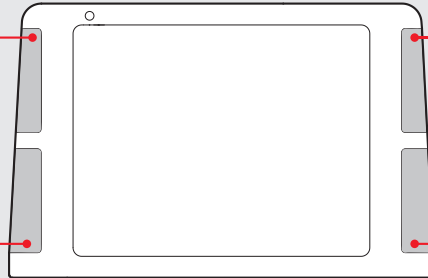

Play Mode

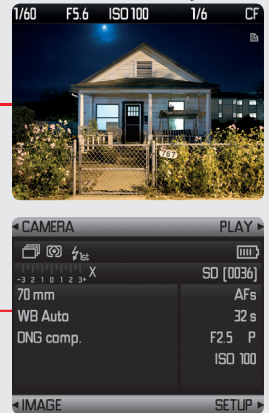

Status Screen

ENTER MENU & PLAY MODE

Section CAMERA



Section IMAGE

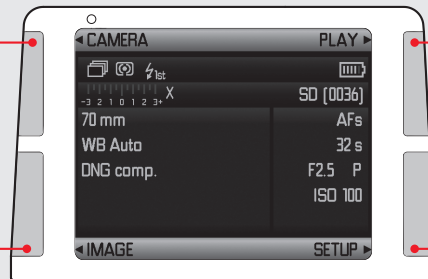

Play Mode

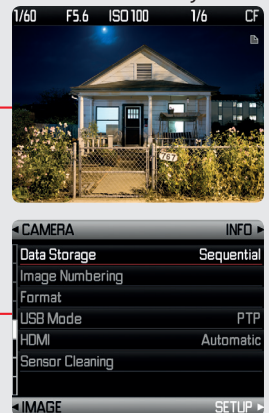

Section SETUP

MENU

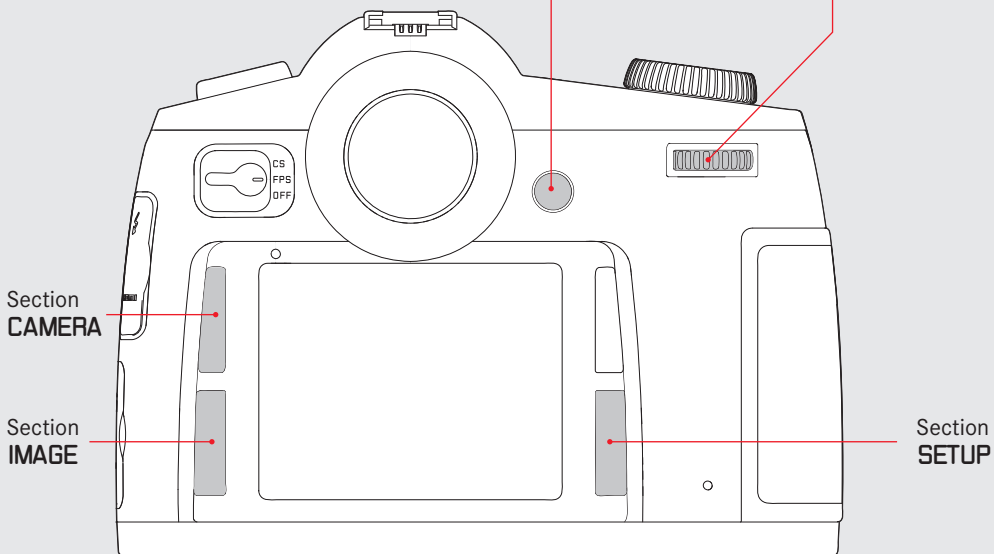
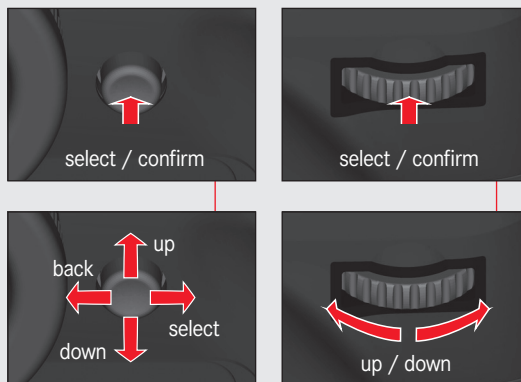

TIP

Press the shutter release button halfway to exit menus and return to Record mode.

MENU - QUICK ACCESS

Long push (1 sec.) leads you straight to your favorite submenu.

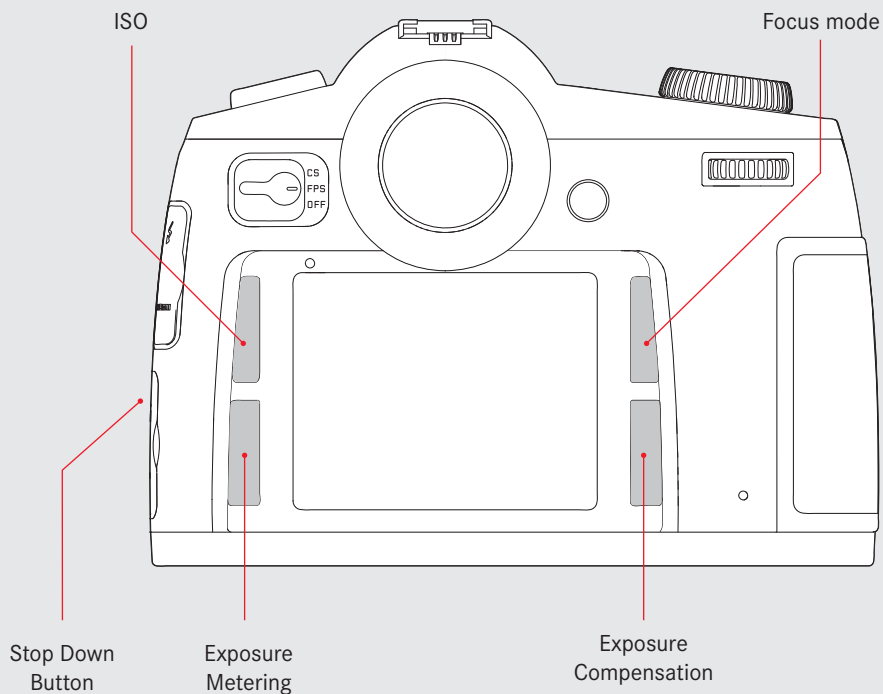

TIP

Setup the buttons to your needs in the submenu CUSTOM FUNCTIONS.

BASIC CAMERA SETUP

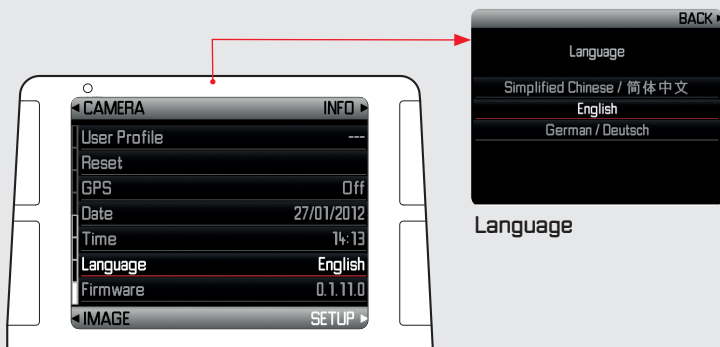
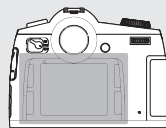

MENU / SETUP (4. PAGE)

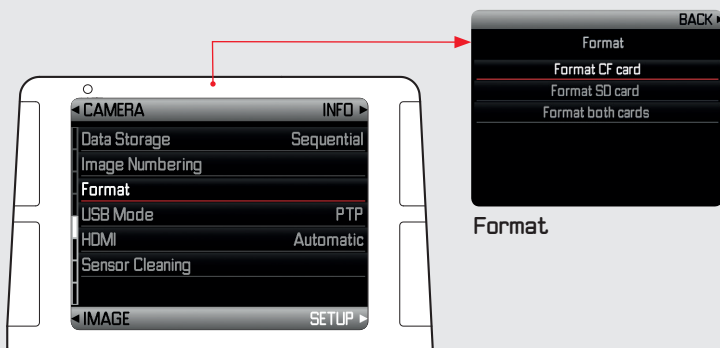

MENU / SETUP (1. PAGE)

BASIC CAMERA SETUP

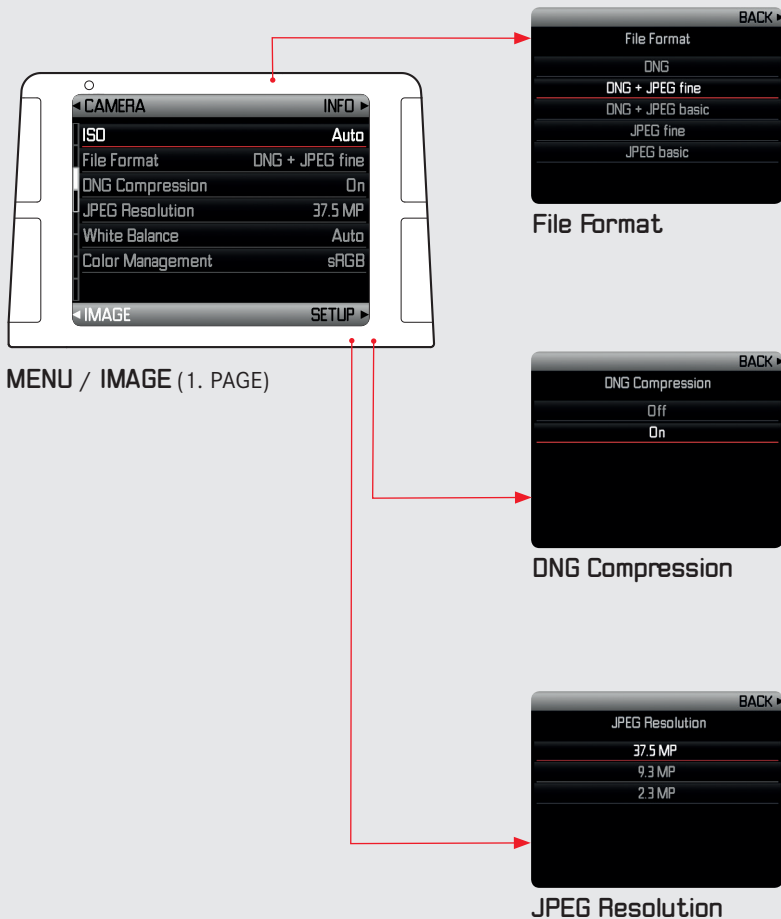
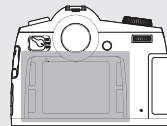

TIP

To save **DNG + JPEG** on separate cards, set **DATA STORAGE** to **PARALLEL**.
DNG Compression will speed up the tethered shooting. Compression is lossless.

PLAYMODE - BROWSE

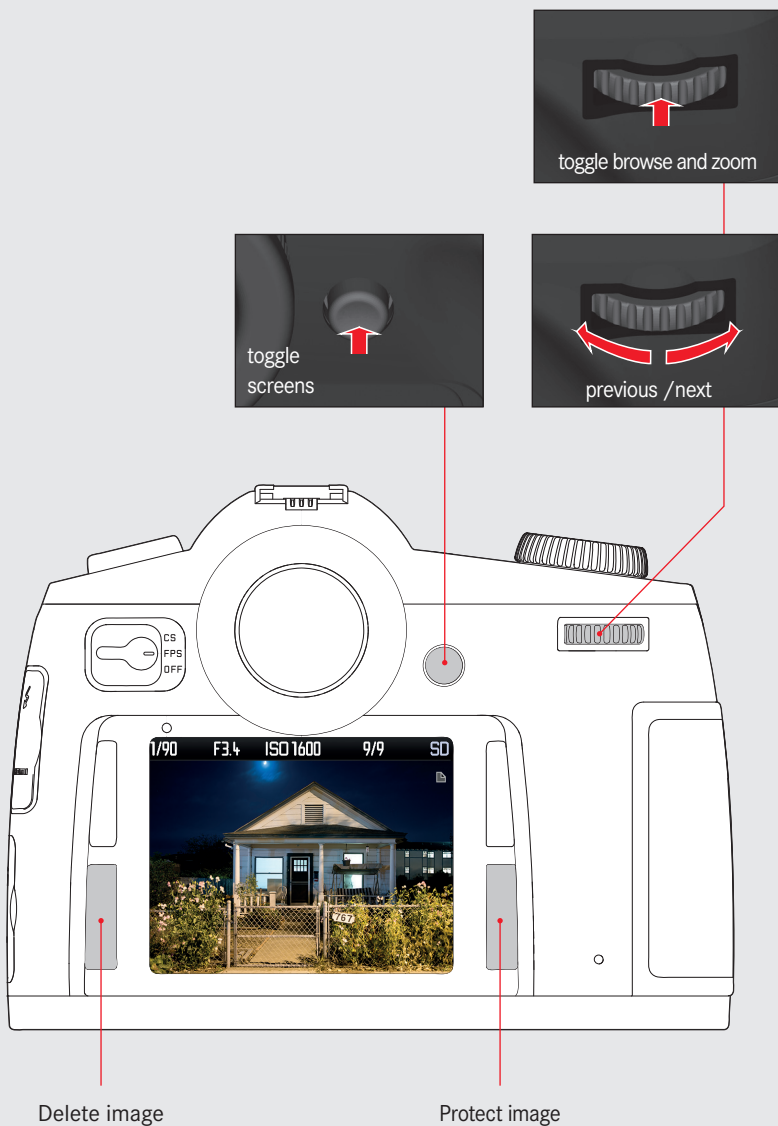

PLAYMODE - ZOOM

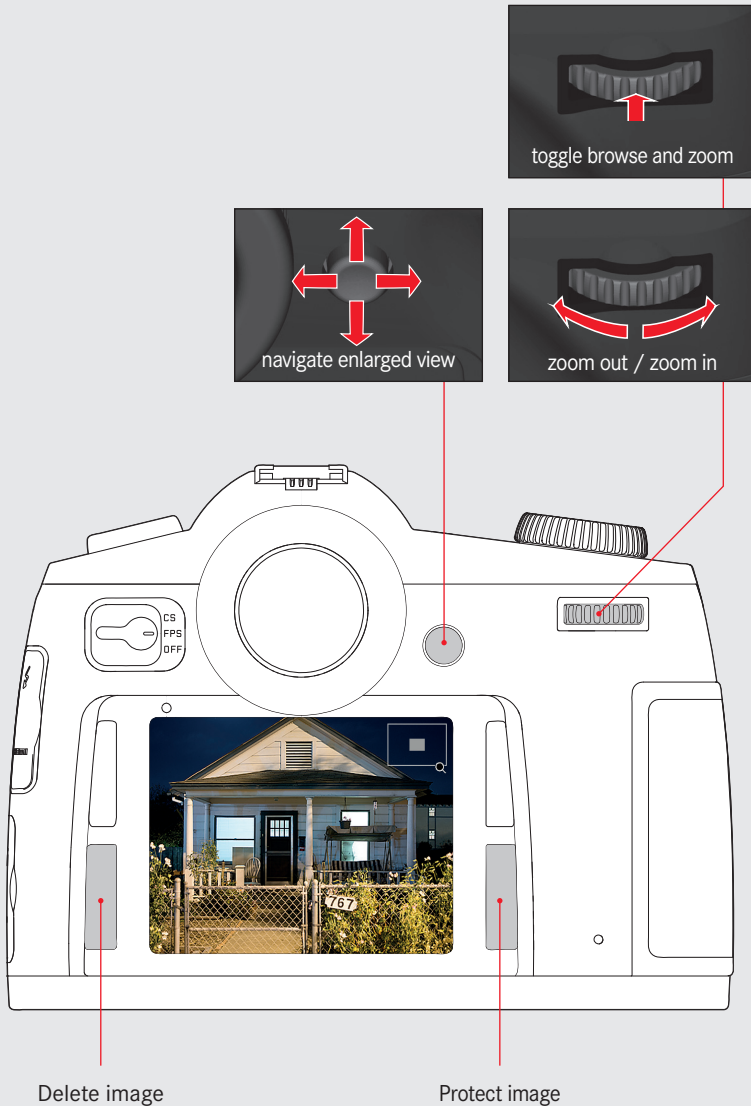

PLAYMODE - SCREENS

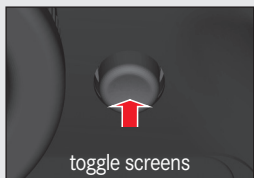
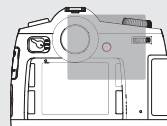

TIP

Camera always shows the latest mode after coming back to **Play** Mode. Histogram represents the visible area of the image. Customize the clipping settings under menu **CLIPPING DEFINITION**.

PLAYMODE - QUICK 100% ZOOM

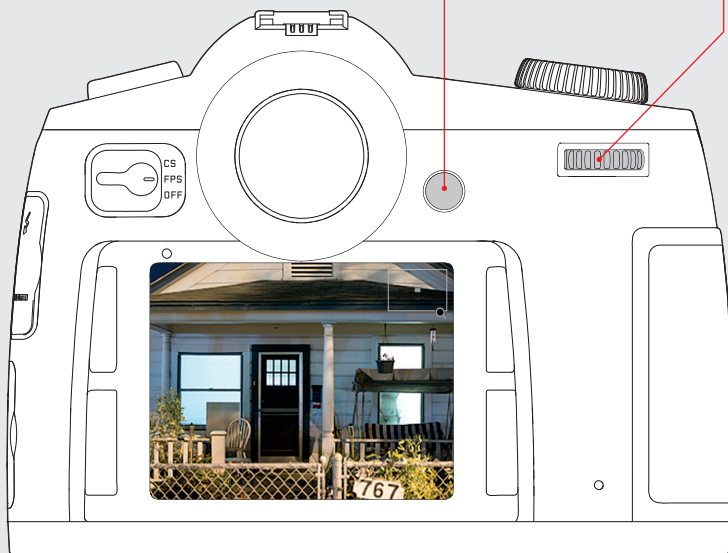
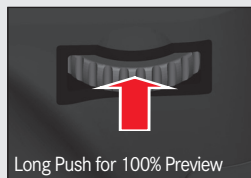
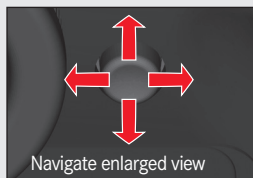
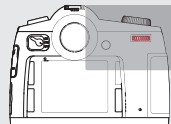

EXPOSURE MODE M, T

Set the shutter speed dial to any time, e.g. 1/125.

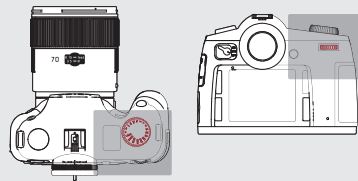

Manual

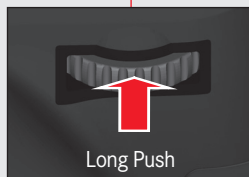
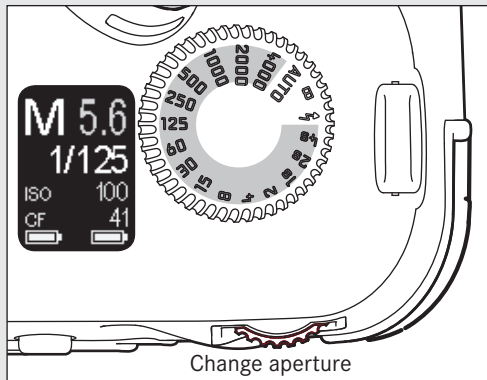

Time priority

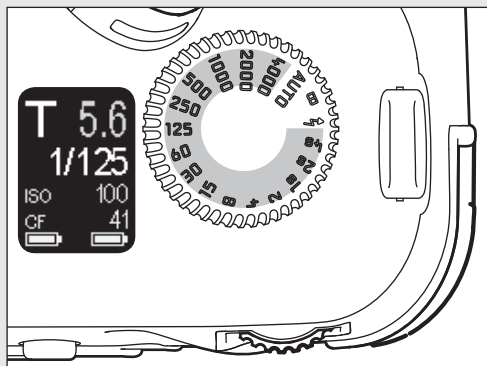

EXPOSURE MODE A, P

Set the shutter speed dial to A.

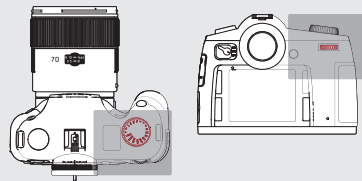

Aperture priority

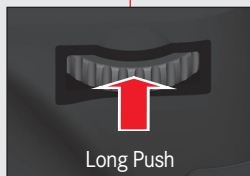
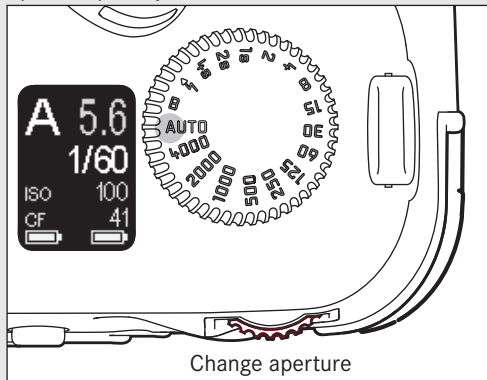

Program Automatic

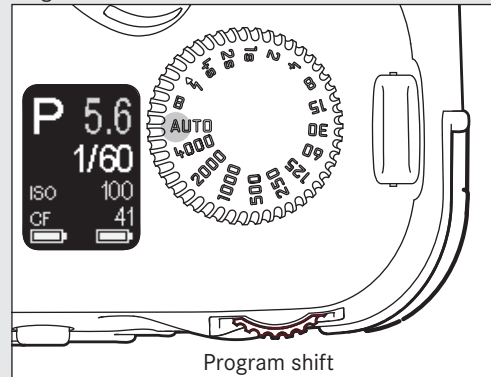

B - BULB MODE / BULB PRESET

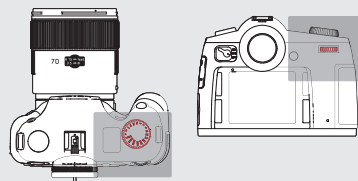

Bulb mode

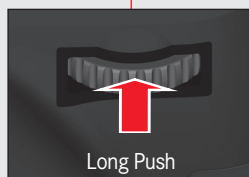
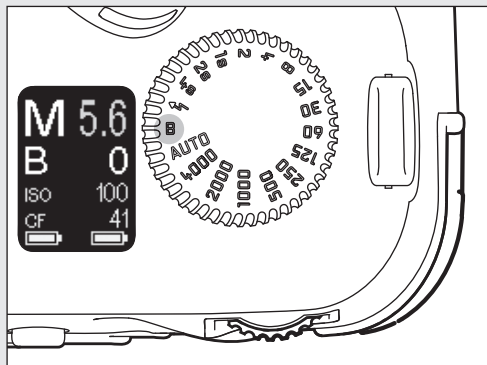

Bulb preset mode

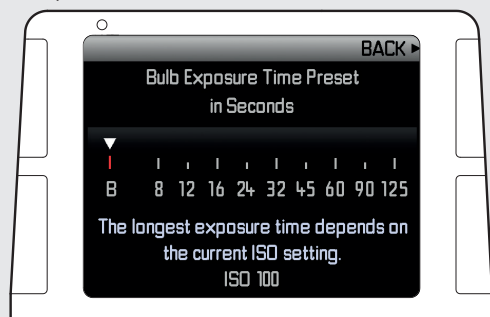

TETHERED SHOOTING - ADOBE™ PHOTOSHOP™ LIGHTROOM™ WORKFLOW

1. Connect the camera with your computer via USB cable.
2. Switch the camera on.
3. Start Adobe™ Photoshop™ Lightroom™.
4. Setup tethered shooting.

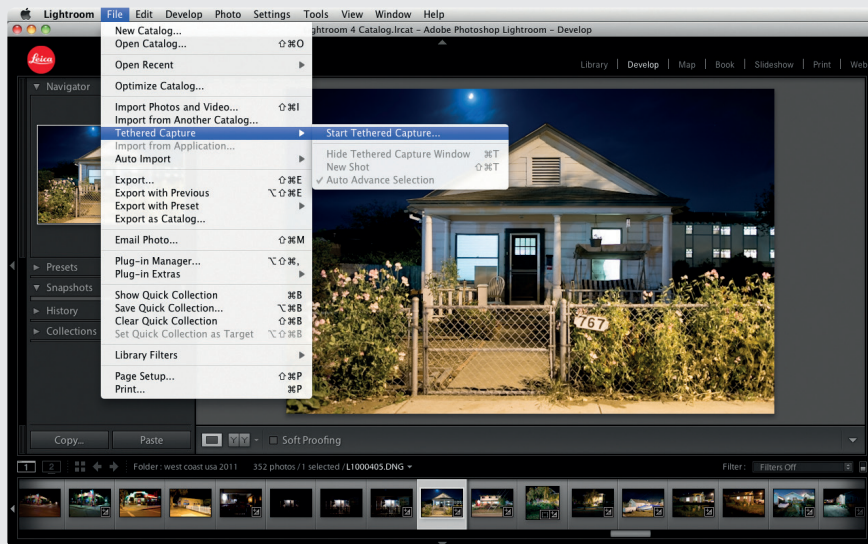
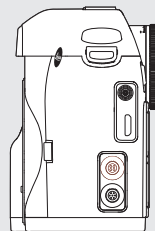

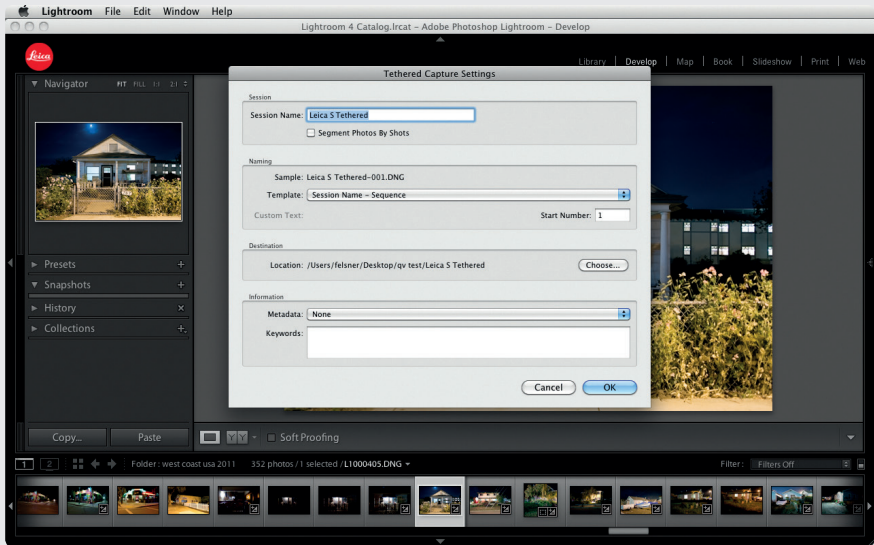

TETHERED SHOOTING - LEICA IMAGE SHUTTLE™ WORKFLOW

1. Connect the camera with your computer via USB cable (PTP storage mode).
2. Switch the camera on.
3. Start Leica Image Shuttle™.
4. Setup tethered shooting.

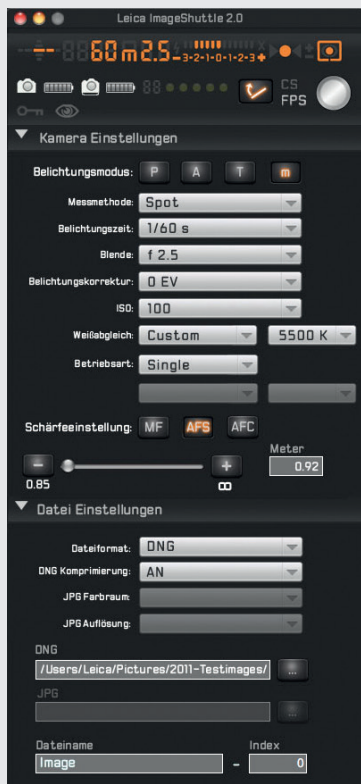
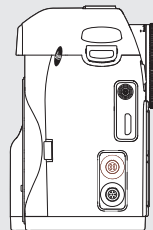

TIP

You can also use Leica Image Shuttle in combination with Adobe Bridge or with the hotfolder function of Adobe PS Lightroom.

MENU LIST

CAMERA

- DRIVE MODE
 - ▶ SINGLE / CONTINUOUS / SELFTIMER 2s / 12s
- FOCUS MODE
 - ▶ AFs / AFc / MF
- EXPMETERING
 - ▶ MULTIFIELD / CENTER / SPOT
- EXPBRACKETING
 - ▶ +/- 3 EV
- AUTO SLOW SYNC
- FLASH SYNC MODE
- MIRROR UP MODE

IMAGE

- ISO
 - ▶ 100 / 200 / 400 / 800 / 1600 / 3200
- FILE FORMAT
 - ▶ DNG / JPG / DNG+JPG
- DNG COMPRESSION
 - ▶ 375 / 93 / 2.3
- JPEG RESOLUTION
 - ▶ PRESETS / GREYCARD / COLOR TEMP
- WHITE BALANCE
 - ▶ sRGB / Adobe RGB / ECI 2.0
- COLOR MANAGEMENT
- CONTRAST
- SHARPNESS
- SATURATION

SETUP

- DATA STORAGE
 - ▶ SEQUENTIAL / PARALLEL / EXTERNAL
- IMAGE NUMBERING
- FORMAT
 - ▶ MASS STORAGE / PTP
- USB MODE
- HDMI
- SENSOR CLEANING
- AUTO REVIEW
 - ▶ DURATION / HISTOGRAM / CLIPPING
- HISTOGRAM
 - ▶ STANDARD / RGB
- CLIPPING DEFINITION
- MONITOR DISPLAY
- AUTO POWER OFF
- ACOUSTIC SIGNAL
- HORIZON
- CUSTOM FUNCTIONS
- AE- AF-LOCK
- KEY LOCK
- CLICK WHEEL EXPMODE
- USER PROFILE
- RESET
- GPS
- DATE
- TIME
- LANGUAGE
- FIRMWARE



my point of view

Leica Camera AG | Am Leitz-Park 5 | 35578 Wetzlar | DEUTSCHLAND
Telefon +49(0)6441-2080-0 | Telefax +49(0)6441-2080-333 | www.leica-camera.com