

# Steadicam® Volt™ User Guide



# Table of Contents

1	Introduction
2	Components
	<b>Volt operating</b>
7	Let's get started!
8	Choosing sides
9	Balance
11	Power on
15	Operating
19	Settings
	<b>Volt Installation</b>
25	Types of installations
29	Installation of Volt complete kit
35	Installation of Volt onto bare gimbals
43	Flip Button
45	Motor belts
	<b>Gimbal upgrades</b>
51	Archer/Archer2 gimbal upgrade
53	Archer/Archer2 gimbal balancing
55	Ultra2, Shadow, Clipper gimbal upgrade
59	PRO CineLive, PRO CineHD gimbal upgrade
63	U2, Shadow, Clipper, PRO gimbal balancing
	<b>Troubleshooting</b>
67	Troubleshooting checklist
68	Frequently asked questions
73	Electronics
75	Contact Tiffen

**TIP:** This table of contents is hyperlinked to navigate you through the respective sections. Page references throughout the manual are also linked to the appropriate page. To return to the table of contents, just click on the page number at the bottom of any page. Easy.



**The Tiffen Company**  
90 Oser Avenue  
Hauppauge, NY 11788  
Visit us at [Tiffen.com](http://Tiffen.com)

# Introduction

## The Steadicam® Volt™

Working with the sled's inertia and neutral balance, the Volt generates an "artificial bottom-heaviness" to keep the horizon level and headroom stable. With Volt, the operator can concentrate on precise framing, timing, navigating, and other more interesting aspects of operating.

The strength of the roll and tilt assistance may be individually fine-tuned to suit the operator's preferences, and easily adjusted for different shots. The assistance can feel like operating a sled with a very long drop time - easy to tilt or roll - to full gyro-simulation, with the sled locked hard to the horizon in roll, or tilt, or both.

Because the sled is always balanced neutrally top-to-bottom, all pendular effects from acceleration and deceleration are eliminated. Plus, there is no re-balancing needed when switching to low mode!



The Volt also allows behaviors that were impossible before. Like "friction mode" which emulates a fluid head with tilt hold and a fixed horizon, bringing you new control options for each and every shot.

In use, the Volt is completely transparent to the operator, and it feels exactly like regular Steadicam operating - with perfect horizons. The operator is always in full and direct control of framing, and can easily override the Volt's assistance.

This user guide is organized to get you up and running quickly; with components and operating up first, then how-to install the popular complete M-2 Volt gimbal kit onto a sled. Further back, we show step-by-step installation of Volt components onto any gimbal, and finally, the factory upgrade steps for older gimbals, should you be so inclined.

Welcome to the future of professional Steadicam operating!

# Components

## Steadicam® Volt™ shown on M-2™ gimbal

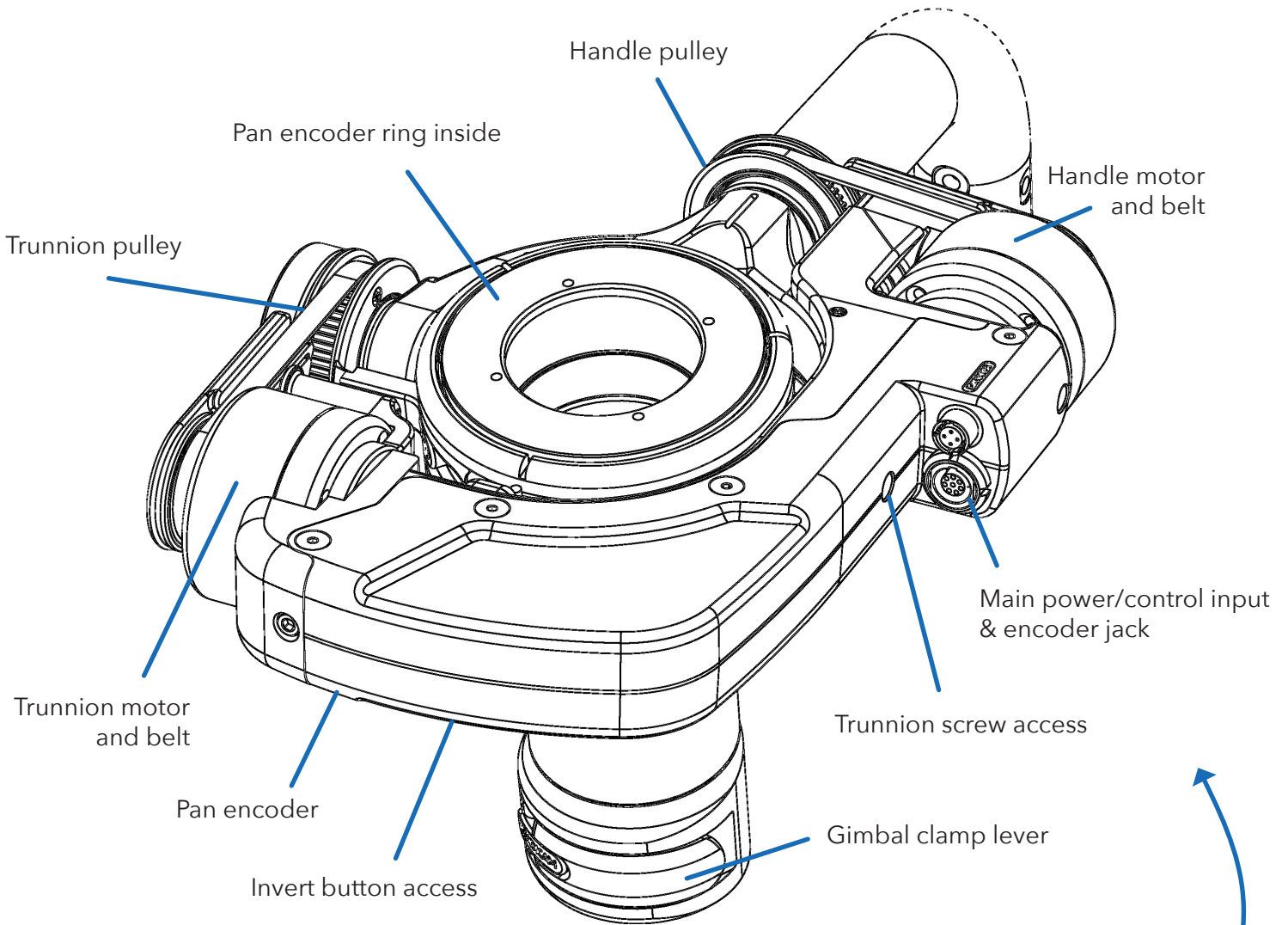

### M-2™ gimbal post spacers

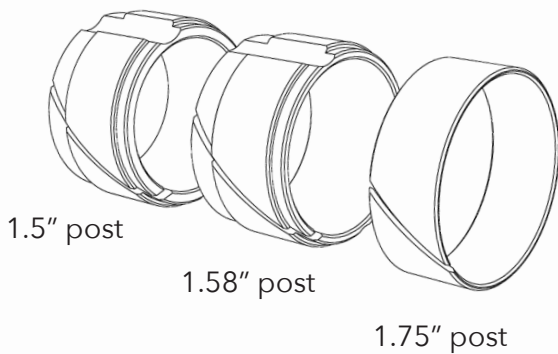

### Thumb button

- Mode LED (green)
- Gimbal button
- Power LED (blue)

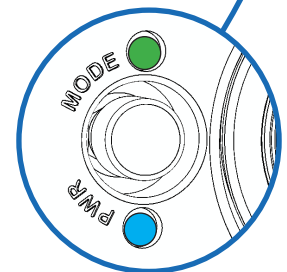

# Components

## Steadicam® Volt™ Control Box

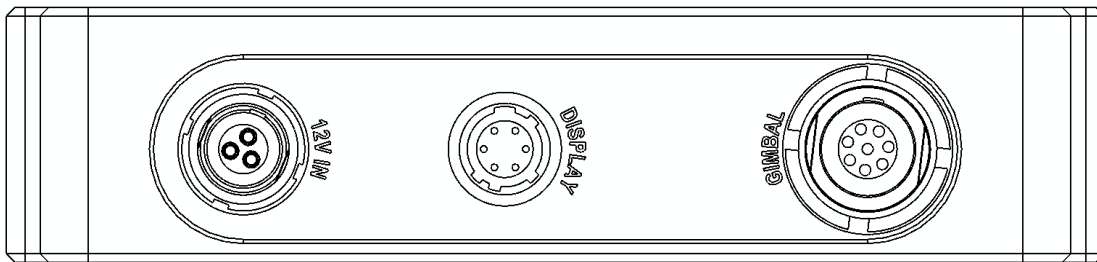
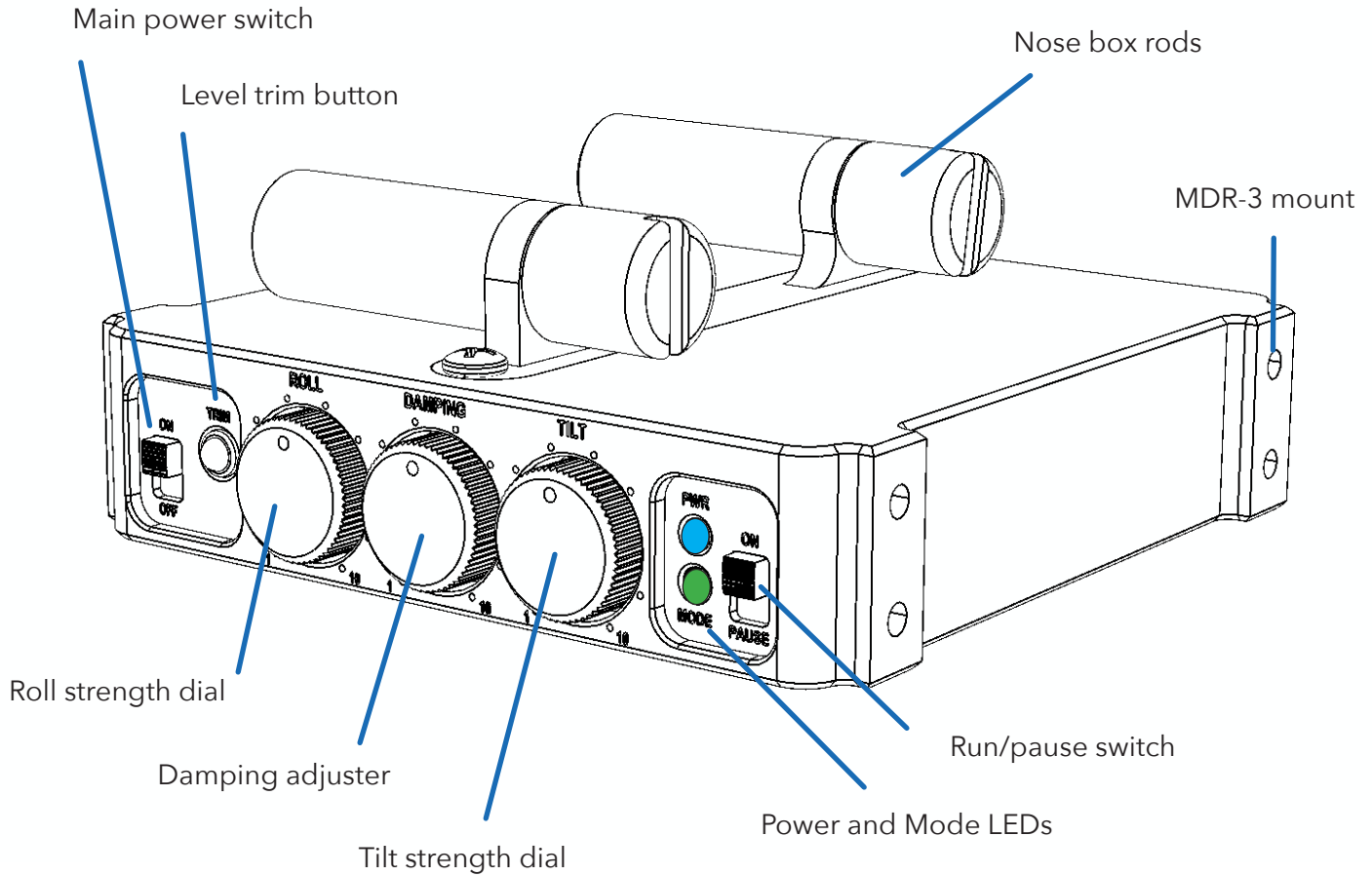

Power input jack from sled  
12V power

Display jack  
(RESERVED)

Main power/control output to  
Volt gimbal motors

**NOTE:** The LEMO connectors rotate up to 90° in the control box chassis to allow you more options when running cables with right-angle connectors.

# Components

## Steadicam® Padded Dock

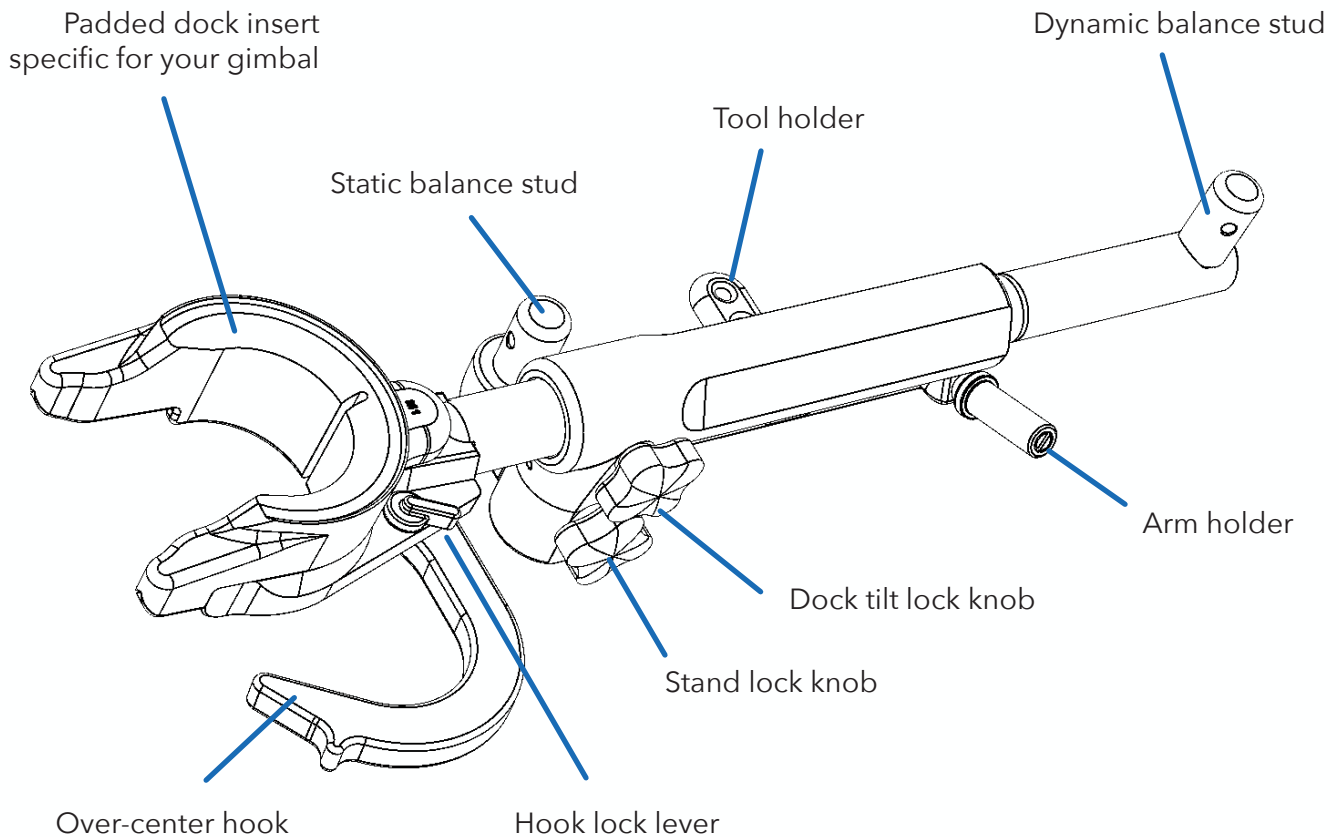

### The new dock

The padded dock is designed to protect the Volt electronics as well as make docking and balancing easier. The low-profile design ensures nothing contacts the Volt gimbal motor assembly when docked, and the “over-center” arm swings into place to secure the sled. Docking on the gimbal also reduces shock loads on your gimbal bearings. You’ll enjoy a low, primary balance stud on the side, which is barely higher than your gimbal handle, making it a simple task to lift for balancing regardless of the sled build. And the dynamic balance stud is adjustable in length to clear your rig for endless spins.

# Components

## Included with Steadicam® Volt™ M-series gimbal kit

- M-2 gimbal with Volt Motor Assembly, internal encoder, pulleys and belts installed and tested
- Volt Control Box (mustache box)
- Gimbal cable, short (817-0135)
- M-2 gimbal post spacers for 1.5", 1.58" and 1.75" posts
- Padded Dock, insert and balance studs for gimbal, and case (817-7980)

## Included with Steadicam® Volt™ upgrade kit for M-1

- Volt Gimbal Motor Assembly, pulleys, belts and hardware
- Volt Control Box (mustache box)
- Pan encoder assembly and pan encoder ring for gimbal
- Gimbal cable, short (817-0135)
- Padded Dock, your choice of balance studs, and case (817-7980)
- Nose box mounting rods
- Spare adhesive tapes for pan encoder ring

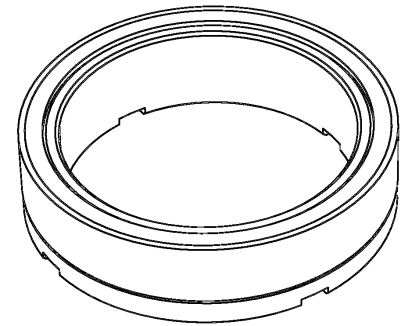

Pan encoder ring

## Also included with upgrade kits for other gimbals

- Volt compatible yoke and mounting kit for your gimbal
- Blue pin wrench for your gimbal
- Mounting options you selected
- Upgrade kit details begin on page 51

## Tools required for installations

- Blue "whale" gimbal tool for your gimbal.
- Imperial Allen key set for install and belt adjustment.
- Flat screwdriver for nose box rods.
- Loctite® 222™ for post top screws and upgrade kits.

**Upgrade kits available  
for these gimbals:**

Archer  
Clipper  
Shadow  
Ultra2  
M-1/M-2  
PRO CineLive  
PRO CineHD  
Betz

Check with Tiffen for the latest  
list of available upgrade kits.

**CAUTION:** The external pan encoder ring included in many kits is a precisely manufactured magnet and should NOT be exposed to strong external magnetic fields before or after installation.

# Control Box mounting options

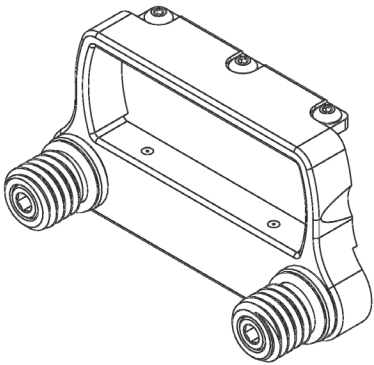

**Nose box adapter**  
Ultra2, Shadow, Clipper, Archer  
(800-7910)

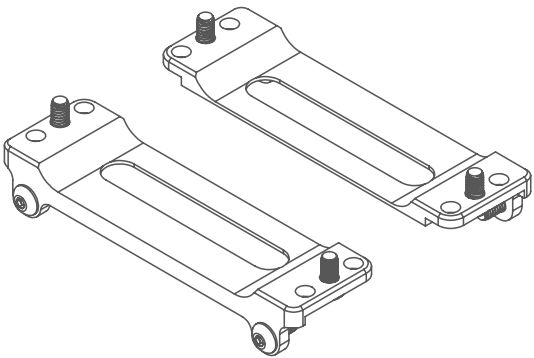

**MDR-3 mount**  
For any MDR compatible setup  
(817-7960)

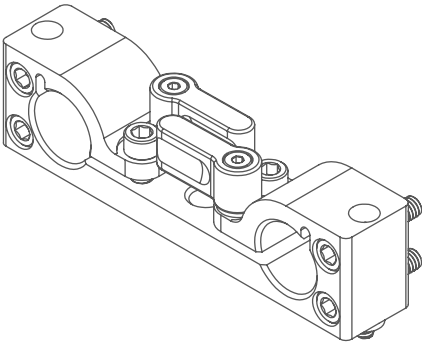

**LWS 60x15 rod mount**  
Attach to nose box rods  
(817-7945)

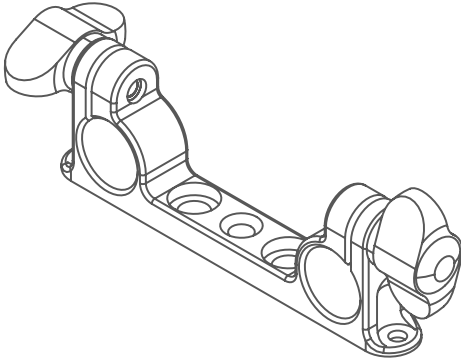

**LWS 60x15 rod mount**  
Attach to nose box rods  
(817-7955)

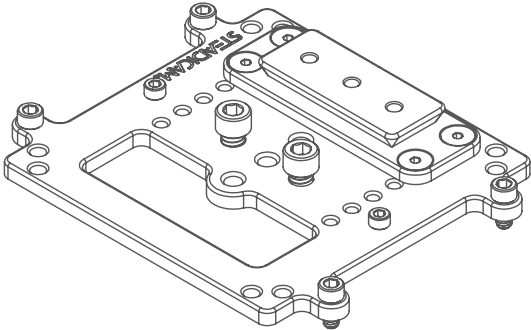

**MDR-3 mount PRO**  
Dovetail plate included  
(817-7915)

# Let's get started!

## Before you begin

The two major components of Steadicam® Volt™, the motor assembly and the control box, contain advanced sensors and electronics. Each may be mounted left or right, to optimize the controls for your operating, but you must be aware of the differences these choices present for the Volt electronics.

- The external Volt control box may be mounted to face regular or goofy-sided operators. If your knobs are to the **right** of the sled (regular operator), you'll align the gimbal handle to the rear of the post on power up. If your knobs are to the **left** of the sled (goofy operator) you'll align the gimbal handle to the front of the post on power up. See page 11 for more info.

### **Right knobs = REAR, Left knobs = FRONT**

- Similarly, the Volt motor assembly may be mounted left or right on the gimbal. This has no effect on powering up, but if you're installing the Volt yourself, be aware that left side is default mode and right side mounting requires pressing the internal "flip" button once to reorient the Volt sensors. See page 43 to learn about the flip button. If the Volt was installed at your dealer, the flip procedure will have been performed already.

We strongly encourage professional installation of the Volt components onto your system by an authorized dealer, but installation instructions for a variety of upgrade paths are provided in this manual.

For more information visit [tiffen.com/steadicam/voltssystem/](https://tiffen.com/steadicam/voltssystem/) or contact your Tiffen dealer.

# Choosing sides

## Notes about left or right side motors

The Volt gimbal motor assembly, casually referred to as the hockey stick, may be mounted to either side of the gimbal yoke. In general, regular operators prefer to mount it to the left and goofy operators mount it to the right. This allows maximum viewability of the monitor and places the gimbal button conveniently near your thumb. However, broadcast users may wish to test fit their zoom controller onto the handle to ensure access to the gimbal button. Also, keep in mind your rest position may need to change if the Volt gimbal motor assembly contacts your body.

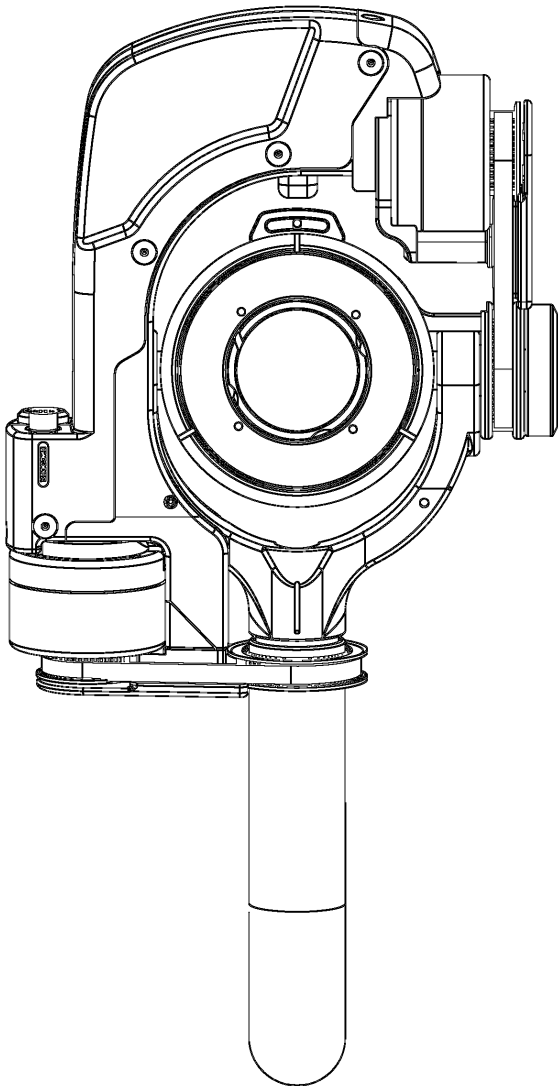

**LEFT side mount  
(typically regular)**

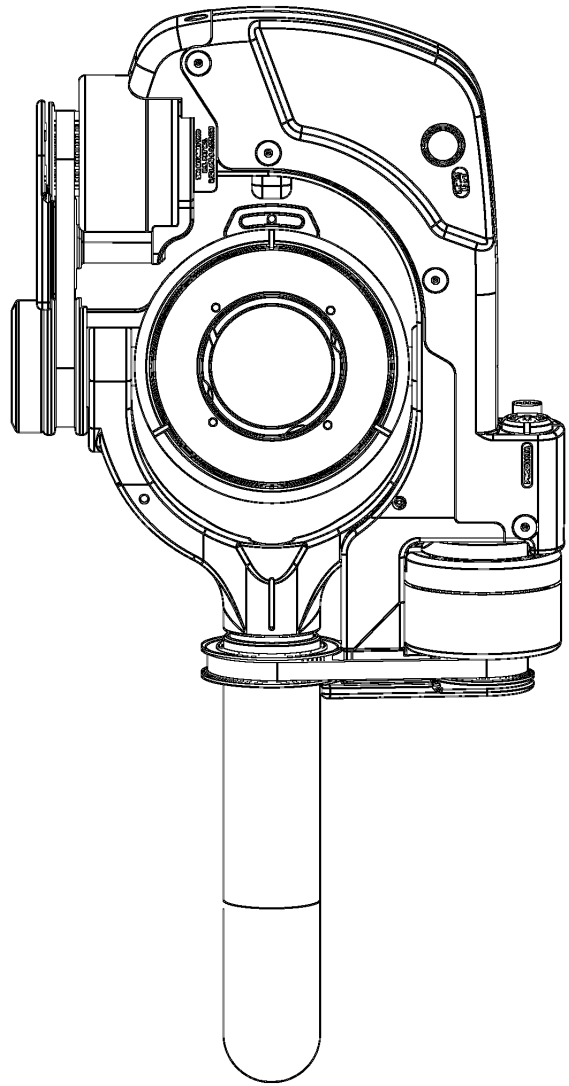

**RIGHT side mount  
(typically goofy)**

# Balance

## Neutral balance

In order for the motors to exert maximum balancing assistance to the roll and tilt axes, we balance the sled completely neutral. No drop time at all! This also eliminates any pendulum effect when accelerating or stopping the sled. Static and dynamic balance are now even more critical, so panning the camera will not create diagonal forces and the sled can easily be held at any angle without rotating.

**TIP:** Build your rig with more pan inertia (monitor and batteries extended) to **increase** stability in the pan axis, which the Volt motors do not affect. This will reduce unwanted panning motions in your image.

Balance the sled with a normal to long drop time. BOTH static and dynamic balance are important here. You know how to dynamic balance, right?

**NOTE:** You may wish to temporarily remove the gimbal cable while dynamic balancing to allow multiple rotations.



Then, change the balance to be completely neutral top-to-bottom. It should hold any post angle and not rotate.

**TIP:** For a refresher on dynamic balancing, see Section One of *The Steadicam Operator's Handbook*.



# Balance



Make sure the sled does not pan when holding a tilt. If so, a tiny adjustment to your side-side balance should correct this.

Otherwise, go back and re-check your dynamic balance.



When changing accessories above the gimbal, like lenses or filters, re-balance on the dock with a normal drop time and then go fully neutral again.

**TIP:** When you change anything ABOVE the gimbal and re-balance at the top stage, dynamic balance is maintained!

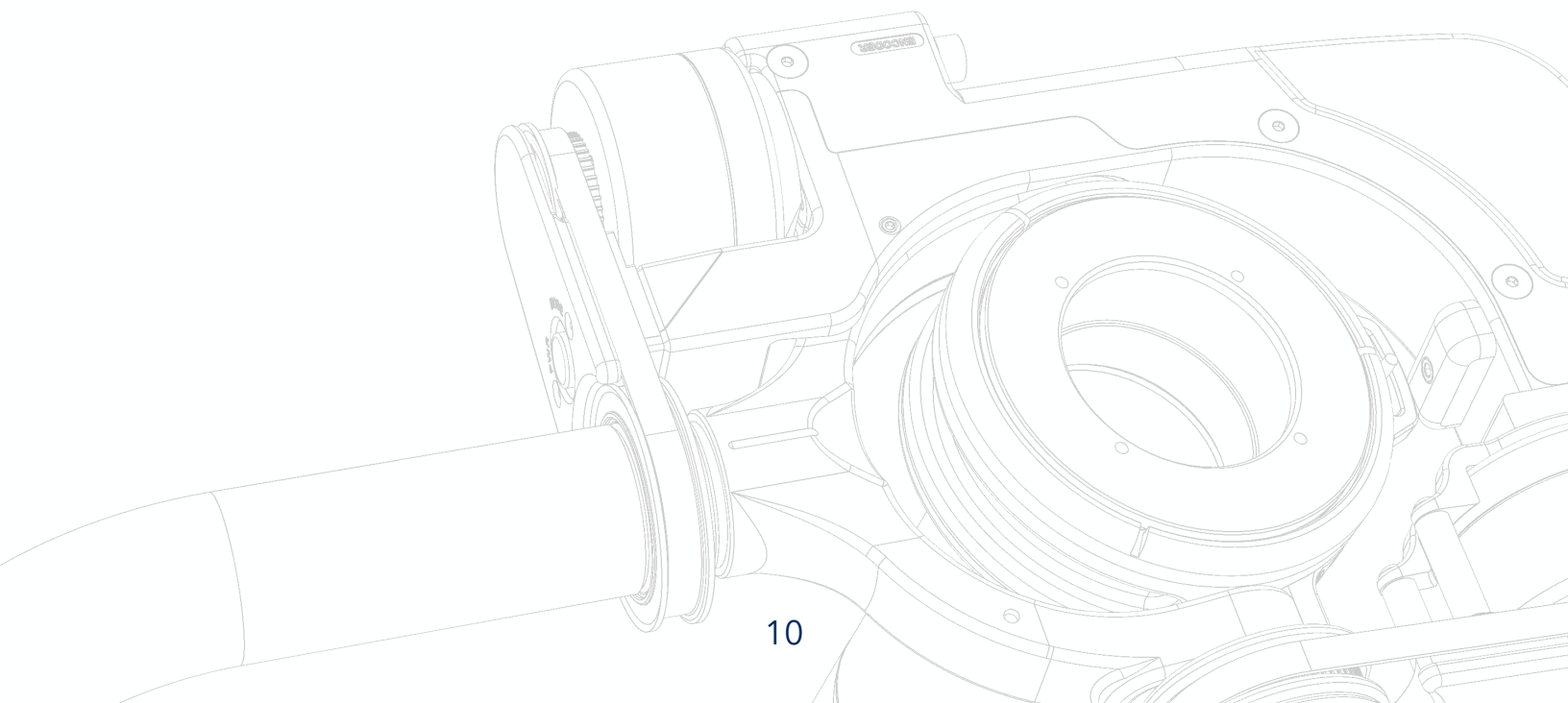

# Power on

## Powering up

Adding the Steadicam® Volt™ to your system requires an extra step when powering up, and when picking up your sled. First, you'll align the pan encoder while powering on, and later you'll run the system when you want the Volt motors active. It'll become second nature, but pay close attention while you're getting started for best results.

**NOTE:** Any sled with **internal** Volt controls, such as an M-2, will always align the gimbal handle with the REAR of the post, no matter which side of the top stage the built-in knobs are installed.

Make sure the power switch is in the OFF position and plug in the power cable from your sled to the Volt control box.

**NOTE:** If you use an aftermarket power cable, confirm the polarity is correct. Volt is protected against reverse voltage, but won't work very well without power.



Plug in the Volt gimbal cable and wrap a couple of loops around the post as needed to control any slack.

**NOTE:** The Volt control box will not power up without the gimbal cable properly connected.



# Power on



Before powering on the system, double check that the PAUSE switch is engaged.

*TIP: Consider using the Roll, Damping and Tilt settings shown here as a starting point. More suggestions on page 21.*

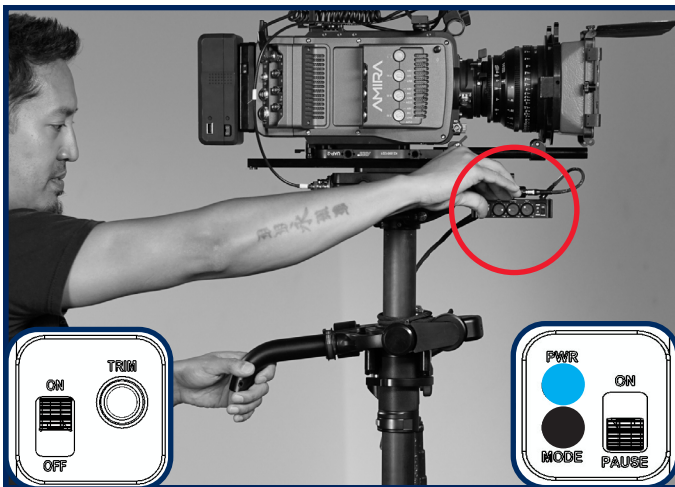

IF the control box is mounted for regular operators (knobs on the RIGHT) align the gimbal handle with the REAR of the post and simultaneously power on the Volt. Wait 2.5sec while the system registers the pan encoder position.

The blue LEDs glow.

You'll do this EVERY TIME you power on the Volt.

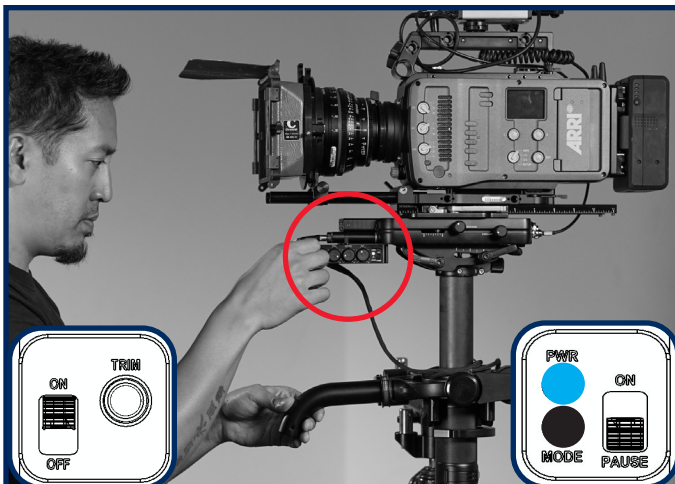

IF the control box is mounted for goofy operators (knobs on the LEFT) align the gimbal handle with the FRONT of the post and simultaneously power on the Volt. Wait 2.5sec while the system registers the pan encoder position.

The blue LEDs glow.

You'll do this EVERY TIME you power on the Volt.

# Power on

Pick up the sled on your arm or use the padded dock's balance pin.

With the post vertical, flip the pause switch to ON and the Volt becomes active.

The green LEDs glow.

You should now feel the horizon assistance and artificial bottom-heaviness of normal mode.

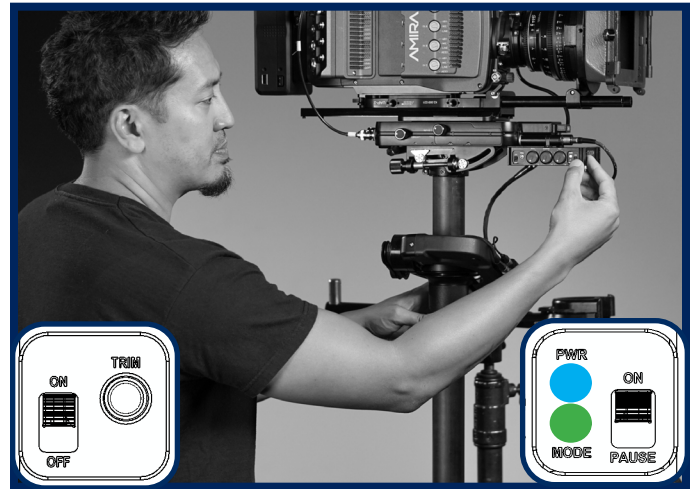

The Volt only needs to have the post encoder aligned when powering on.

Pausing and activating the Volt can be toggled with the handle in any orientation.

If you do power down, remember to align the handle again when powering back up.

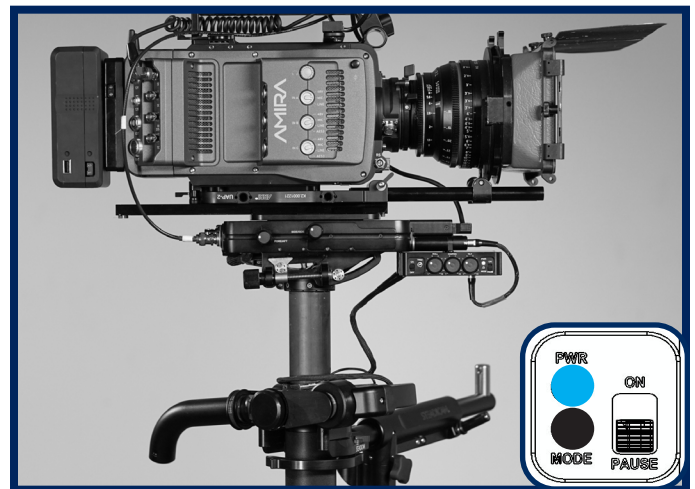

Powering on the system sets the roll and tilt trims to default horizon for a vertical post with level tilt head.

In the next section, we'll explore trimming and modes.



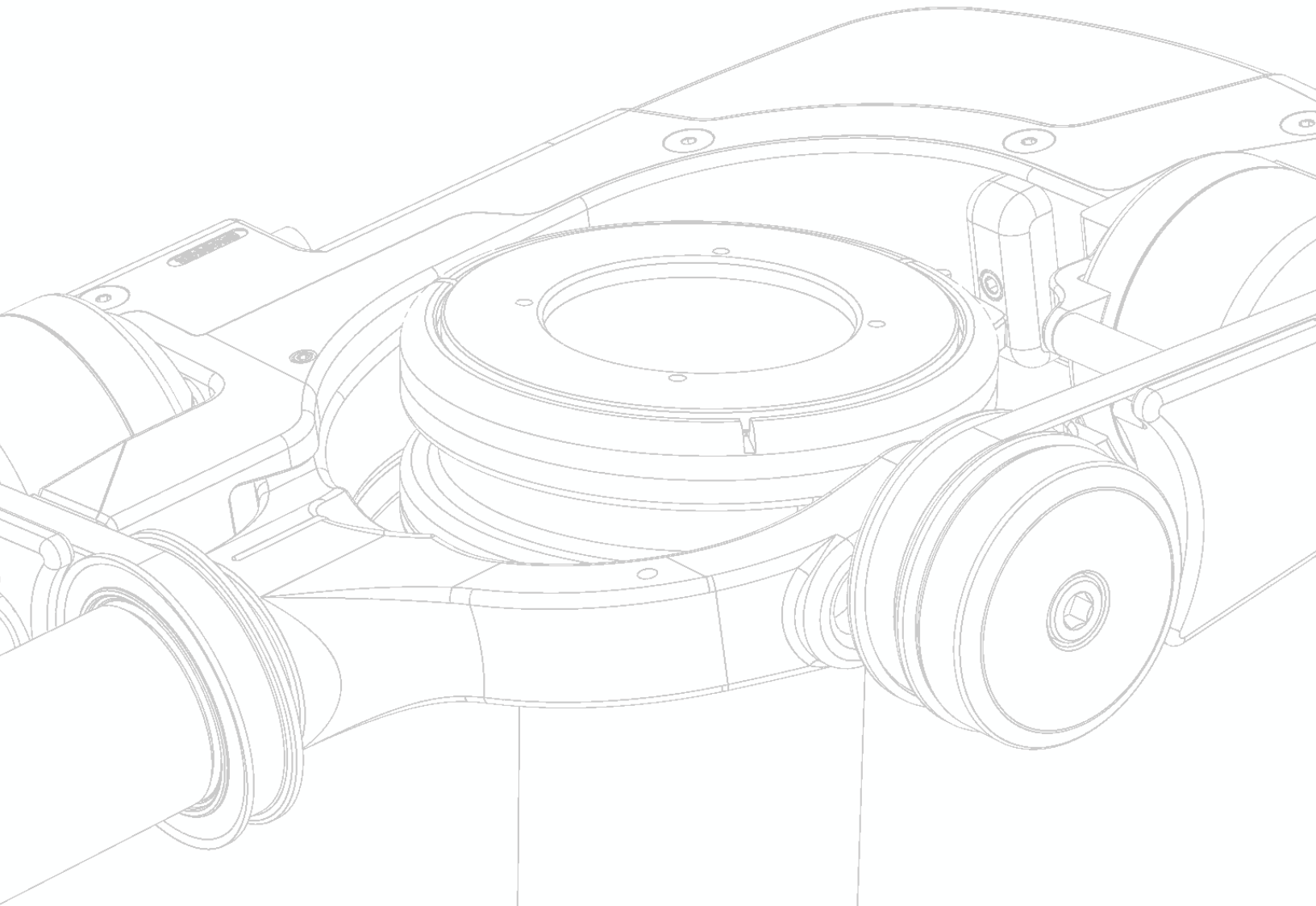

# Operating

## Operating with the Steadicam® Volt™

The best thing about adding this tool to your system is that you're still operating a mechanical stabilizer, and using your skills and years of experience to craft each shot. Here are some tips on how to optimize the Volt, starting with trimming the post angle and the two operating modes. We'll adjust the control box dials later.

To trim, tilt the sled to any angle and SHORT-press the gimbal handle (thumb) button. The new trim angle is set immediately.

In normal mode, the artificial bottom-heaviness will return the sled to THIS angle.

This can be done on the fly, during the shot - a huge advantage to your operating.

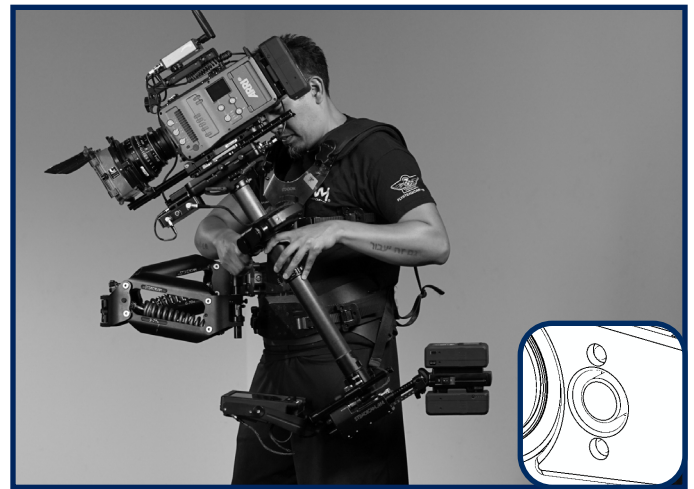

DO NOT TRIM with your top stage balance like we used to...

Leave the sled in perfect neutral balance at all times!



# Operating



The two operating modes are toggled with a LONG press of the gimbal button.

In normal mode, the sled will return to your trimmed tilt angle, simulating a normally balanced Steadicam sled.

Normal mode is always default and displays SOLID green LEDs.



The second mode is called the “Friction mode” and displays PULSING green LEDs.

In friction mode, the sled will remain tilted where the operator places it and require force to change tilt position.

It’s like having a fluid head on your Steadicam!



Using your sled’s integrated tilt head maintains the vertical post, ideal for panning.

First, pause the system, change the tilt and re-balance the sled.

Then run the Volt and set a new tilt trim by short pressing the gimbal button.

# Operating

Should you wish to set the ROLL trim, SHORT-press the trim button on the control box and position the sled to the new level position while the LEDs blink for 5 seconds.

When LED blinking stops, your new horizon position (or Dutch angle) is now stored in memory.



To reset the roll horizon to default, LONG-press the trim button on the control box for 6 seconds until both LEDs on the control box turn off and pulse back on.

Horizon is now reset.

Any previous TILT trim will be maintained.



Quick low mode is now easier than ever! When flipping, there is no need to re-balance because the sled is neutral.

Simply invert the sled and rotate the monitor for viewability.

**NOTE:** If you tilt the head, make sure to set a new trim.



# Operating



The included padded dock is essential to protect the Volt's motors and electronics. Other methods of docking may damage the unit.

Always use the over-center hook while docked.

**TIP:** You can remove unnecessary docking rings from your post and gain precious gimbal height!

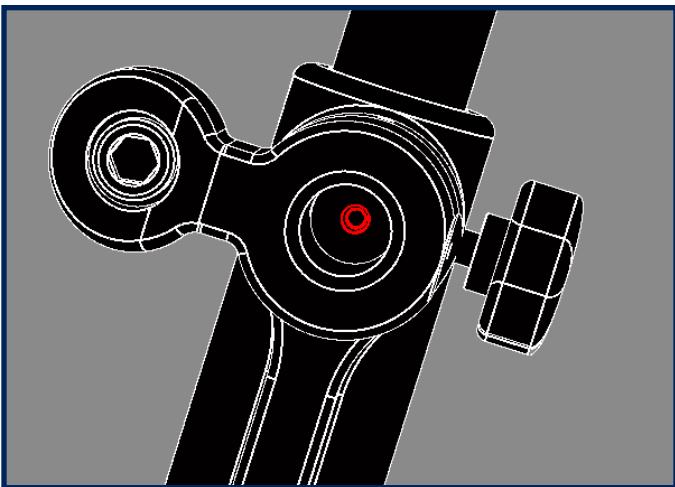

The dock offers the ability to tilt the gimbal up to 30° while remaining docked and secure.

To enable this feature, remove the set screw from beneath the stand mount with a 1/8" Allen key.

Tilt angle is now secured with the tilt lock knob pictured.



**TIP:** Instead of using the tilt dock for lock-off shots, you can also place the rig on the balance stud and engage the Volt motors.

Setting trim will hold the shot with next to no operating required!

# Settings

## Control box settings

The three dials on the control box allow you to customize the behavior of the Volt in two axes, roll and tilt, independently. Additionally, the damping dial controls how the system returns the sled to vertical. Here are some general guides to all of the control box switches and knobs.

The trim button on the control box has two functions:

- SHORT-press sets ROLL trim to the current post angle.
- LONG-press of 6 seconds reverts roll trim to default.



The pause switch is there to keep the Volt powered on and tracking the encoder and motor positions.

Pausing does NOT require you to align the gimbal handle again, and your previous trim setting will be maintained.

It's great for quickly re-balancing or standing by.

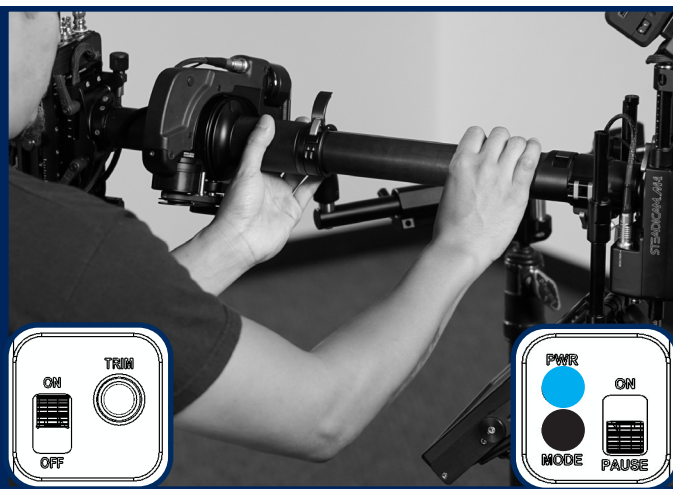

# Settings



The ROLL dial controls the strength of the motors in the roll axis. This equates to how strongly the rig seeks a level horizon side-to-side.

To help retain subtlety of control, start with low assist levels and add strength as needed for each shot.

More isn't always better!



Damping works like friction to keep the sled from oscillating.

Set the damping in proportion to your TILT strength, but use as little as possible.

The operator should do most of the damping (like normal operating) rather than letting the electronics do it.



The TILT dial controls the strength of the motors in the tilt axis. This alters the behavior:

In normal mode, more tilt strength equates to stronger artificial bottom-heaviness.

In friction mode, more tilt strength equates to firmer hold at the operator's set post angle, like drag on a fluid head.

# Settings

## Recommended settings

Try these settings for the different situations listed. These recipes are just a starting point; experiment, starting with reduced strength and find exactly what works best for you, for each shot.

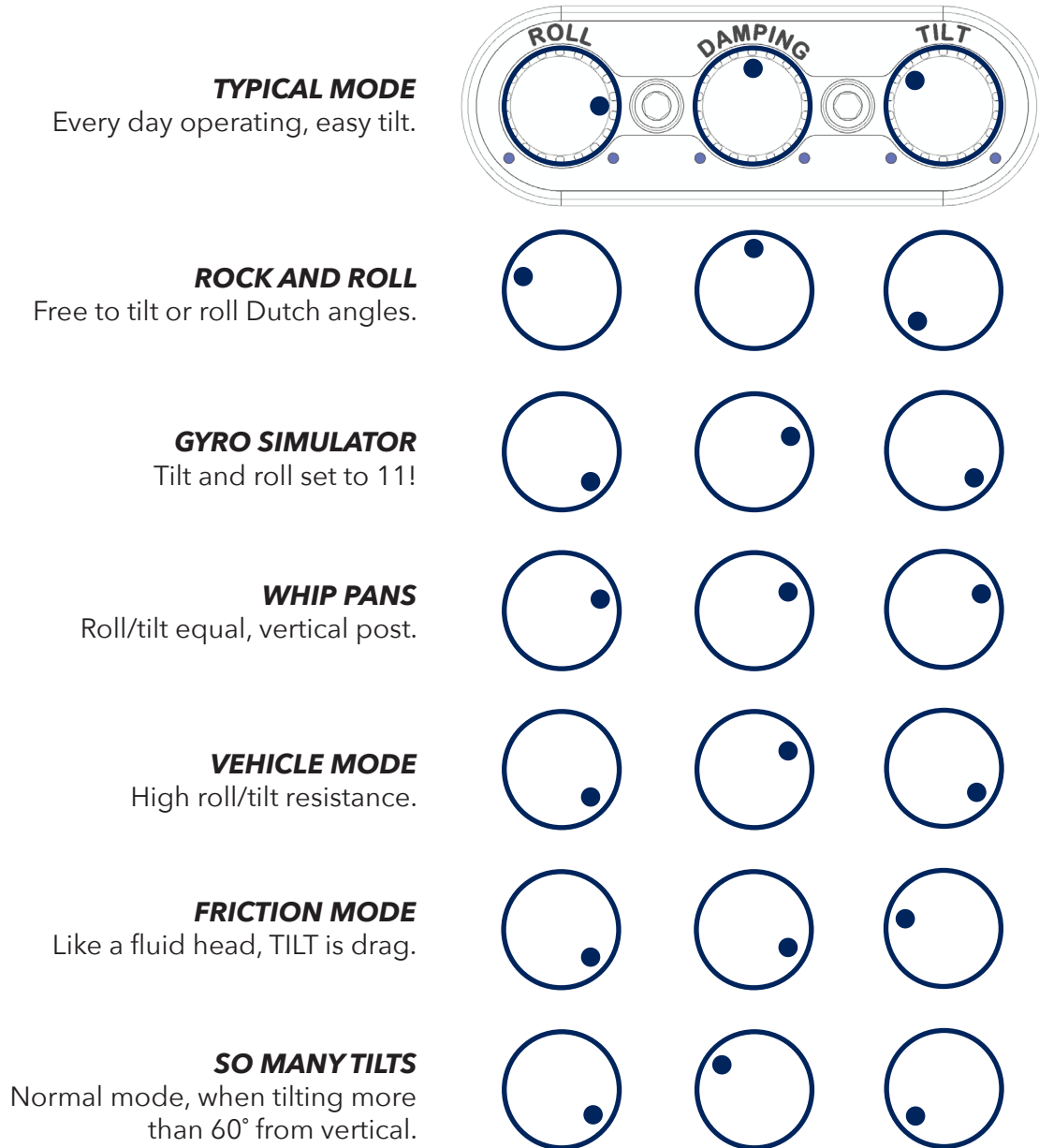

# Settings

## Additional thoughts on settings:

- Use higher motor strength in both axes for heavier rigs and rigs with more inertia, like long mode. Less strength for lighter or tighter rigs.
- Damping becomes LESS effective with increased motor strength settings. Tune this to taste.
- Full tilt assist is available to 22.5 degrees from vertical, HALF assist at 45 degrees, and ZERO assist beyond 67.5 degrees, allowing extreme tilts and a natural rest position without the motors intervening.
- When using friction mode, increasing the TILT strength enables the sled to “stick” to a tilt angle with more authority. It’s similar to the drag setting on a fluid head. Use as little TILT as necessary to match the inertial resistance of your pan axis for the smoothest diagonals.
- Share settings with other Volt operators as we all explore the future of Steadicam® operating!
- For more information visit [tiffen.com/steadicam/voltsystem/](https://tiffen.com/steadicam/voltsystem/)

STAND



# Types of installations

## Installing Steadicam® Volt™ yourself

Most operators add Volt to their rigs by ordering the complete M-2 gimbal with the Volt motor assembly already installed on their preferred side, ready to go. We'll cover the steps involved with complete gimbal installs first, followed by the full install of Volt components onto all compatible gimbals later.

**The steps involved are:**

### ***Complete Volt gimbal kit:***

- Install Volt control box to your top stage using included and optional hardware
- Swap existing gimbal with new M-2 gimbal and Volt motor assembly
- Add power and gimbal cables, balance, and you're ready to fly!

### ***Volt gimbal upgrade kits:***

- Install Volt control box to your top stage using included and optional hardware
- If necessary, upgrade and balance legacy gimbals to Volt compatibility using optional Volt yoke kit
- Add pan encoder ring, pulleys, Volt motor assembly and belts to gimbal
- For right-side mounted Volt motors, flip the electronics orientation
- Add power and gimbal cables, balance and you're ready to fly!

### ***Before beginning you should decide two details:***

- Which side of the sled you'll mount the control box knobs.
- Which side of the gimbal you'll mount the motor assembly.

See page 7 for more details on choosing sides.

**NOTE:** we recommend familiarizing yourself with the complete install procedure before starting.



# Installation

## Adding the Control Box

All Volt upgrades mount the control box to the nose of the sled. Remember, the knobs may face either side, typically to accommodate regular or goofy operators, but this will impact how you align the encoder when powering on the sled each time.

Mounting the Volt control box onto an integrated rod system, like on an M-1 or M-2, is easy. If you're using rod adapters or MDR plates on other rigs, make sure the control box is affixed rigidly to the sled. Any vibration can lead to unwelcome oscillations, so get it tight.

**NOTE:** for instructions on installing an internal Volt control board into an M-2 sled, see the M-2 manual.

Add the included short rod extensions to the nose box of your M-1 or M-2 top stage and tighten with a flat head screwdriver.

Slide on the control box, with knobs oriented to your preferred side, and secure with the threaded rod caps. Tighten with a flat head screwdriver.



Ultra-2, Clipper and Archer rigs may utilize the nose box adapter.

Remove the three Allen screws from the top of your nose box, slide the adapter onto the rig and fasten with the included Allen screws.

Snug down the assembly by tightening the two set screws on the bottom.

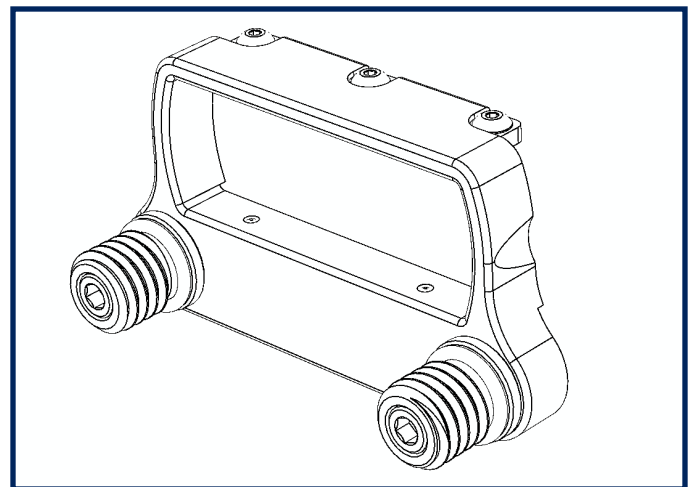

# Installation

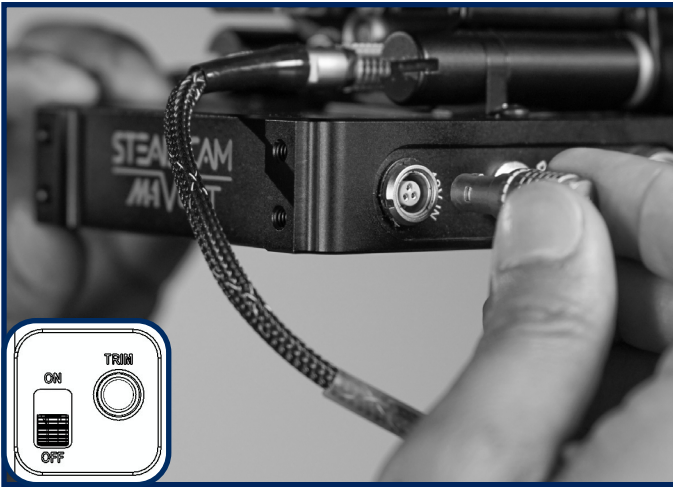

Ensure the power switch is in the OFF position and connect the short power cable from sled power to the 12V IN port.

**NOTE:** If you use an aftermarket power cable, confirm the polarity is correct. Volt is protected against reverse voltage, but won't work very well without power.



**REMEMBER:** If your control box is mounted with the knobs to the RIGHT (regular), you'll align the gimbal handle to the REAR when powering on later.

However, if your box is mounted with the knobs to the LEFT (goofy), you'll align the gimbal handle to the FRONT when powering on later.

See page 11 about power up.

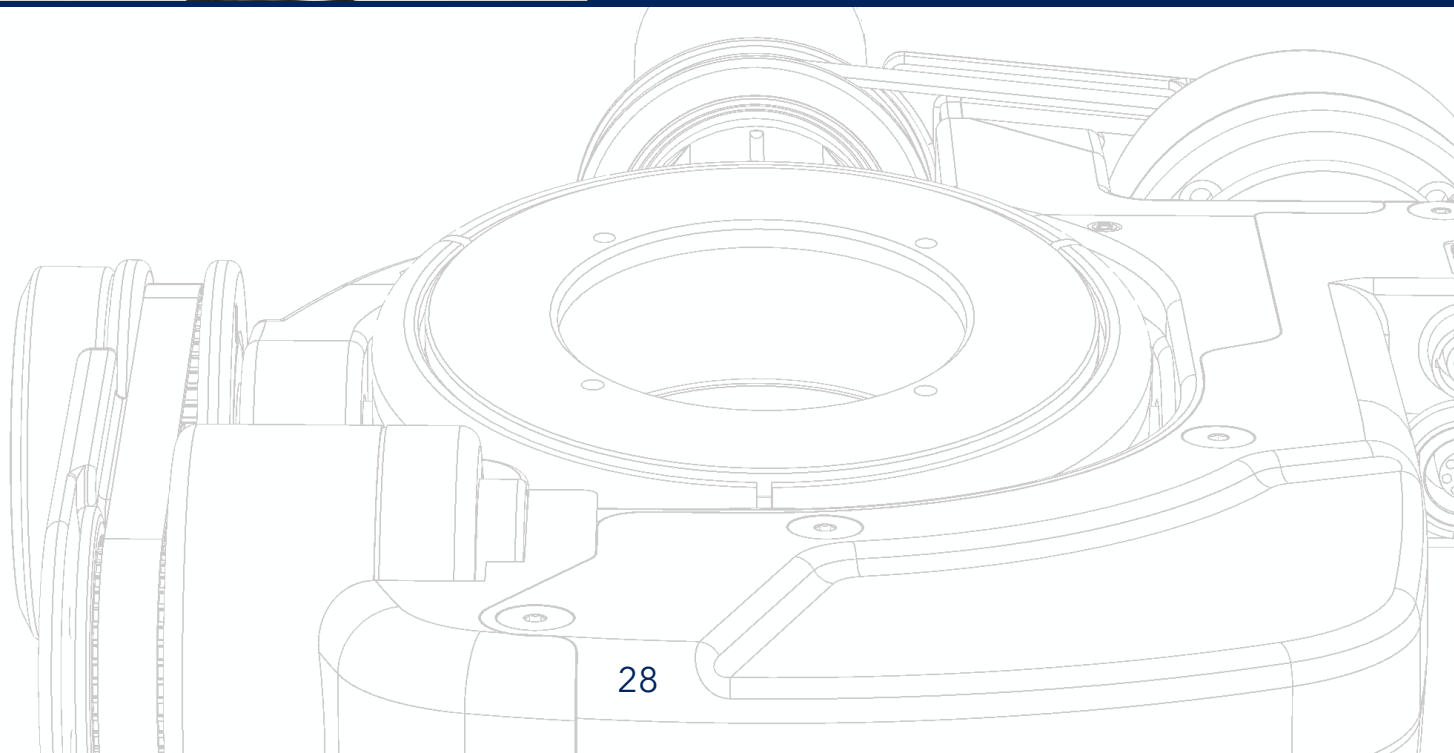

# Installation of Volt complete kit

## Swapping gimbals

The M-2 gimbal has been designed to accommodate posts of 1.5 in, 1.58 in and 1.75 in diameter by incorporating snap-in inserts. The complete Volt kit includes a balanced M-2 gimbal with Volt motor assembly installed on your chosen side, ready to be installed.

Start by removing the top stage of your rig. Refer to the user manual of your rig, or consult service experts if this is the first time disassembling your system. With the top stage removed, you should be able to slide your old gimbal off.

Select the appropriate pair of M-2 gimbal inserts for your post.

They are matched sets, one for the top and one for the bottom of the gimbal.

If there's any doubt which set to install, use a set of calipers to accurately measure the post diameter in a few places.

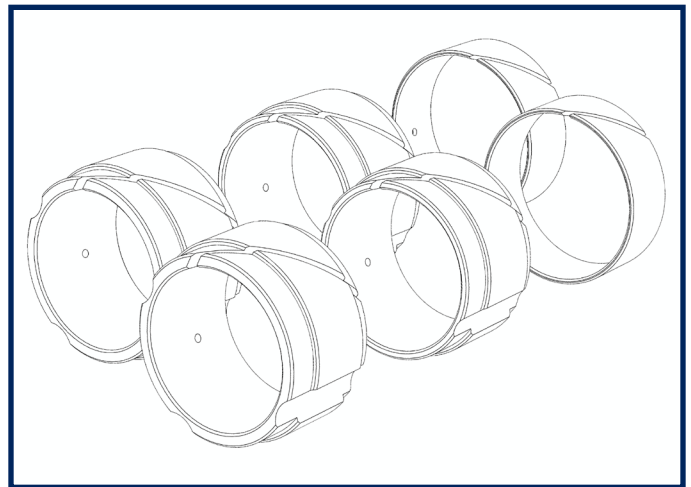

Install the top post insert.

They just squeeze in with little effort.

For 1.5" and 1.58" posts, the shorter flange is oriented UP, so the insert is flush with the top of the gimbal when installed.

Radial alignment does not matter.

The insert should \*click\* into place.

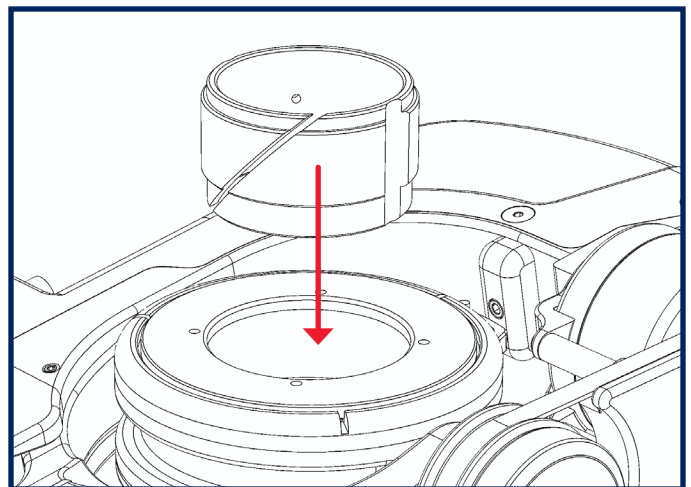

# Installation

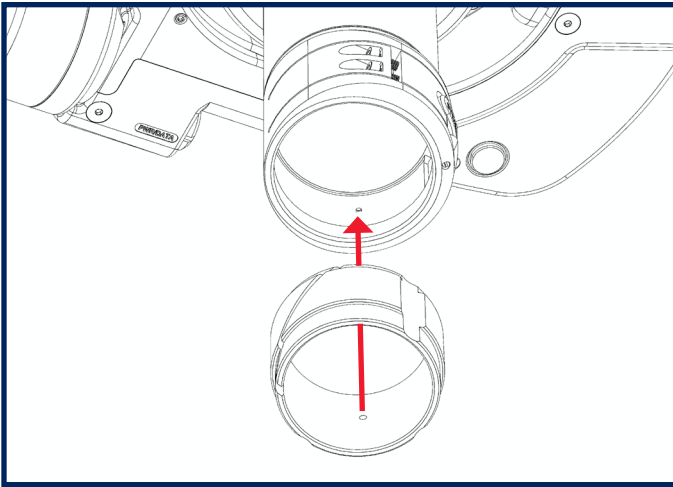

Next, add the lower post insert.

There is a locating pin inside the gimbal which must be indexed with the hole in the insert.

For 1.5" and 1.58" posts, the shorter flange is oriented UP, so the insert is flush with the bottom of the gimbal when installed.

The insert should \*click\* into place.

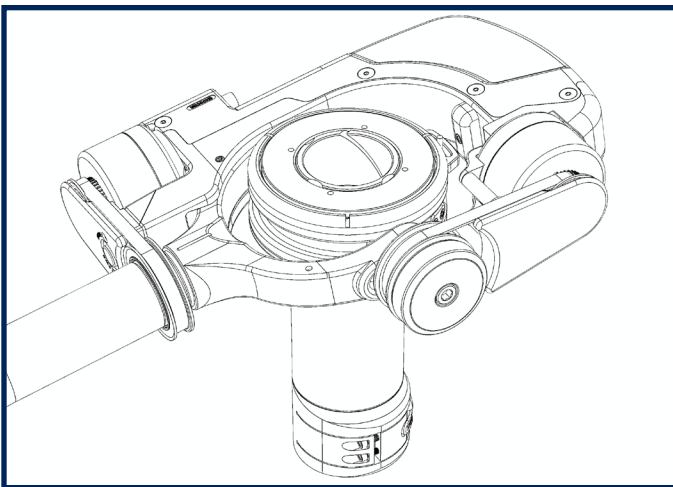

Test fit the gimbal onto the post.

Test the gimbal clamping ability across the entire usable area of the post. The low-profile clamp is easy to use and offers a positive lock.

**NOTE:** Some posts are slightly wider at the top, so the gimbal might be snug at first, then looser once it's past the top. Be gentle.

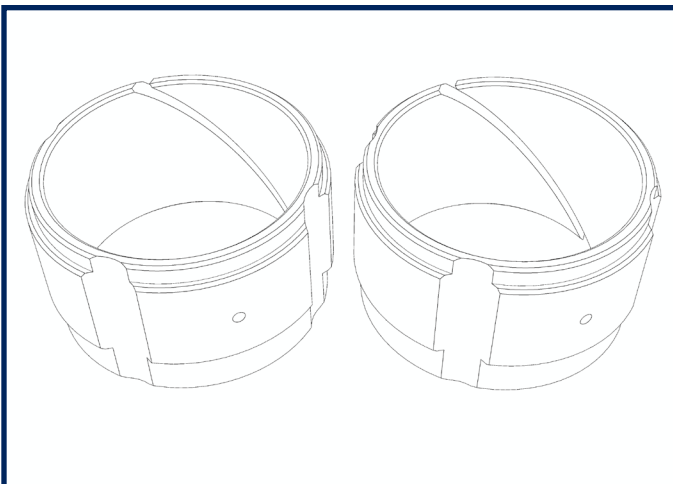

Some adjustment to the spacer thickness may be required, using fine sandpaper.

Remove the spacers from the gimbal, sand a small amount evenly around the inside of the spacer, clean off any dust, and reinstall to test the fit.

# Installation

When necessary, the over-center lock on the gimbal is adjusted with the clamp lever CLOSED.

Use a 3/32" Allen wrench to turn each screw an equal, tiny amount. You don't want to over-tighten these, so take your time.

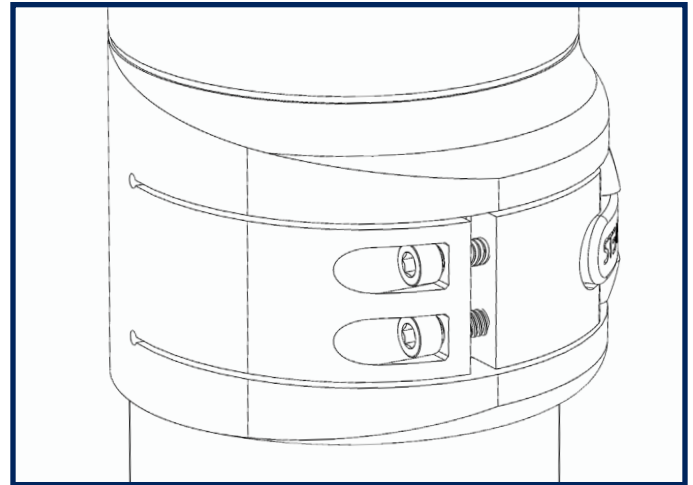

Test the action of the clamp lever, and the holding power of the clamp.

Repeat if necessary.

**IMPORTANT:** Do not over-tighten the gimbal clamp! It is strong enough to distort carbon fiber post sections, but does not need to be that tight to hold. Use minimum clamping force while still holding securely.

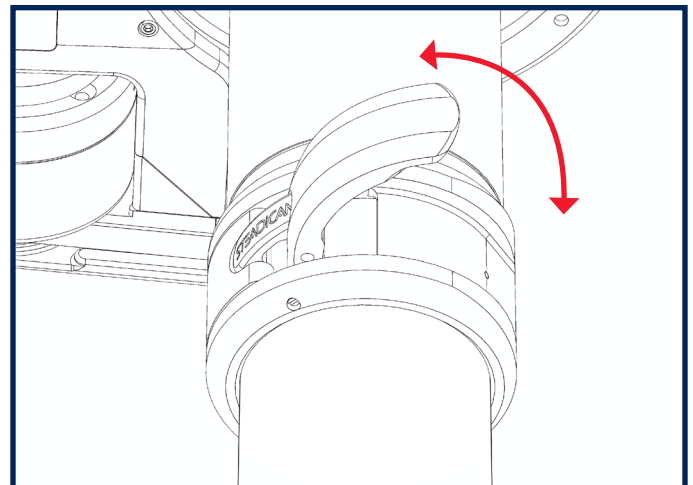

When you're satisfied with the fit and clamping performance of the M-2 gimbal, reinstall the top stage.

Ensure all electronic and mechanical connections are secure.

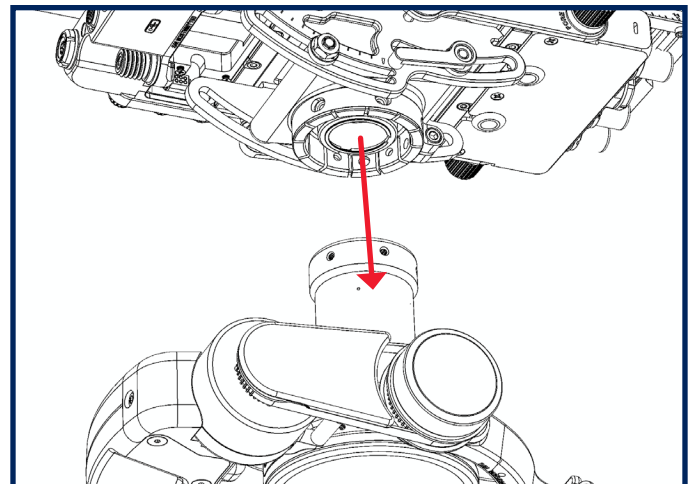

# Installation



Plug in the 90° end of the gimbal cable to the control box, wrap a loop or two around the post and plug in the Volt.

The LEMO connectors rotate 90° in the control box to allow for convenient cable placement.

*TIP: Depending on your normal builds, you may prefer the optional "long" gimbal cable.*



**NOTE:** For preassembled Volt gimbals, you do NOT need to press the flip button. This procedure was done at the factory.

Your Volt equipped sled should be ready for action! Now go back to page 9, and get ready to balance before powering on.

STAND



# Installation of Volt onto bare gimbals

## Steadicam® Volt™ for M-1, M-2, Ultra2, Shadow, Archer, and PRO gimbals

Professional installation is recommended, but a mechanically inclined, professional Steadicam® operator such as yourself should be able to install a Volt in roughly an hour. Unlike other “horizon” gadgets, you’ll probably never want to take it off. The initial steps for adding Volt to ALL gimbals require you to pull the gimbal from your post, so take particular care if this is the first time you’ve disassembled the components of your system. The remaining steps can be performed with the gimbal ON or OFF the post, though you may find installing the belts easier with it removed.

- If you’re upgrading a non-Volt-compatible gimbal, first exchange the yoke and balance the gimbal using the notes starting on page 51. Then return to this page to add the Volt gimbal motor assembly.
- If you’re adding Volt to an M-2 gimbal, these instructions also work, with a few differences noted.

**NOTE:** This portion of the manual takes you through a detailed RIGHT-side install on an M-1 gimbal, with special notes for LEFT-side installs. The two sides are essentially mirror images with minor differences.

**CAUTION:** The external pan encoder ring included in many kits is a precisely manufactured magnet and should NOT be exposed to strong external magnetic fields before or after installation.

To install the pan encoder ring onto the gimbal of any rig, you must first remove the top stage from the post to gain access to the gimbal.

The modular design of the M-1 and M-2 makes this extremely easy.

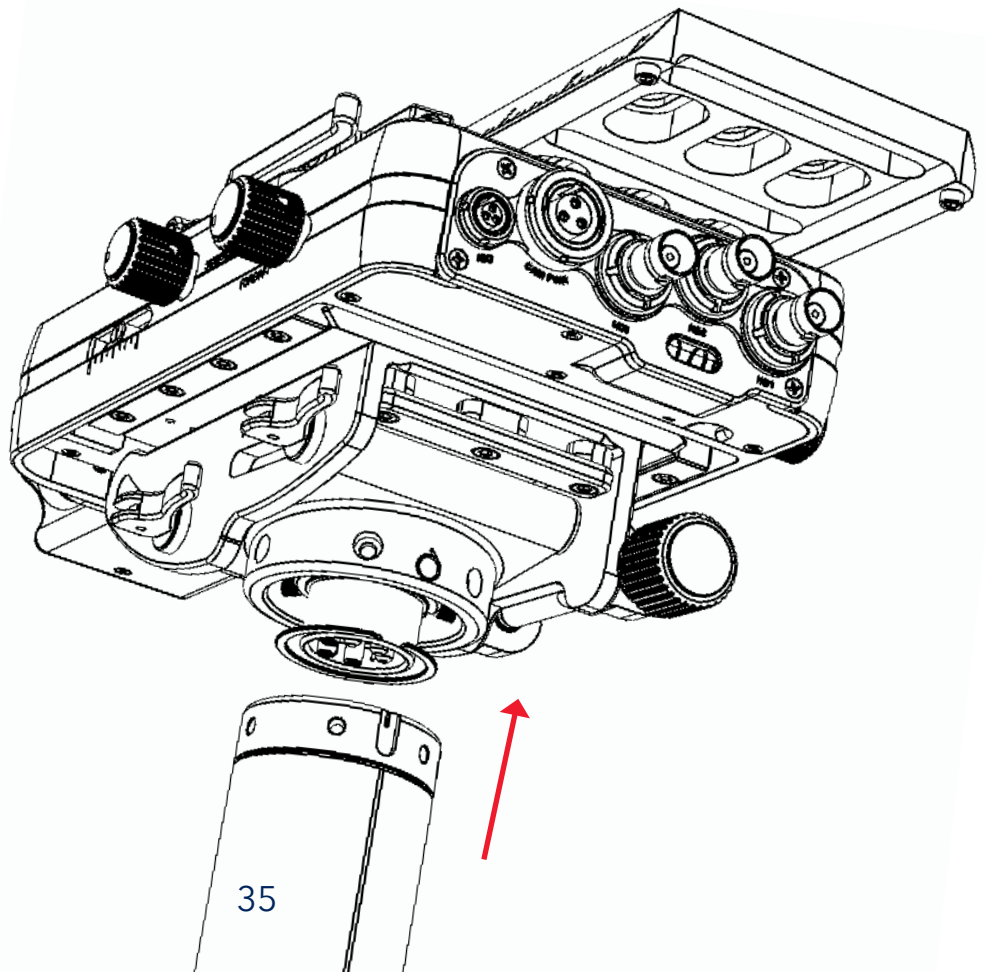

# Installation

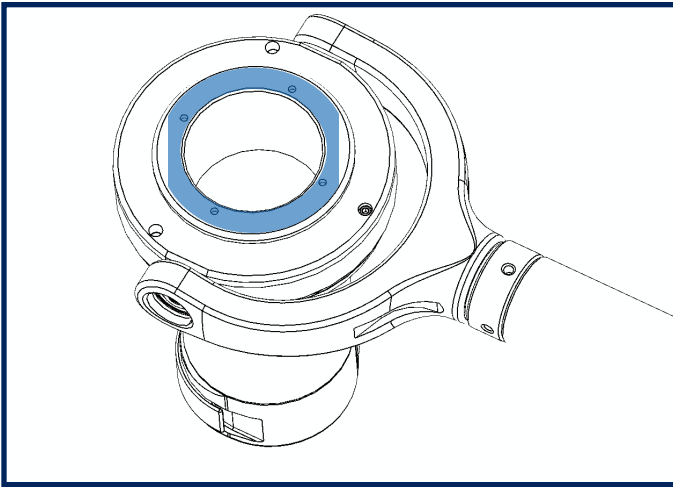

Take a moment with your blue whale wrench to make sure the gimbal top cap is tight and everything spins smoothly.

Use alcohol to clean the top cap when you're done.

**NOTE:** The pan encoder ring will cover the wrench holes. Future gimbal servicing may require removing the encoder ring.

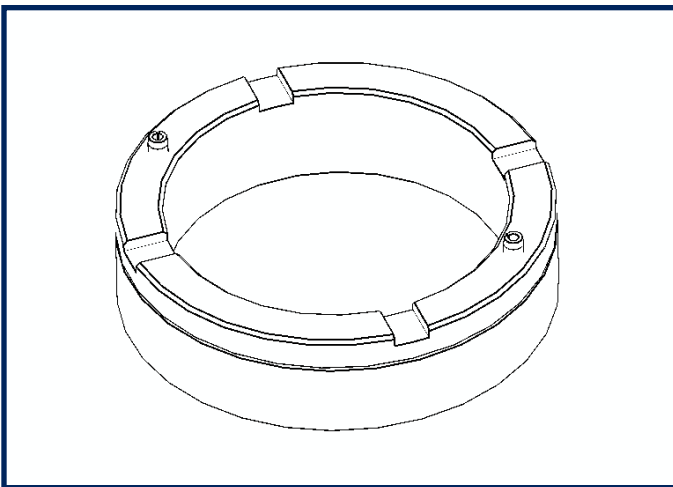

Peel off the backing from the four adhesive strips on the pan encoder ring.

Careful, this stuff is sticky!

**NOTE:** M-2 gimbals include an encoder ring built into the gimbal. Skip these steps.

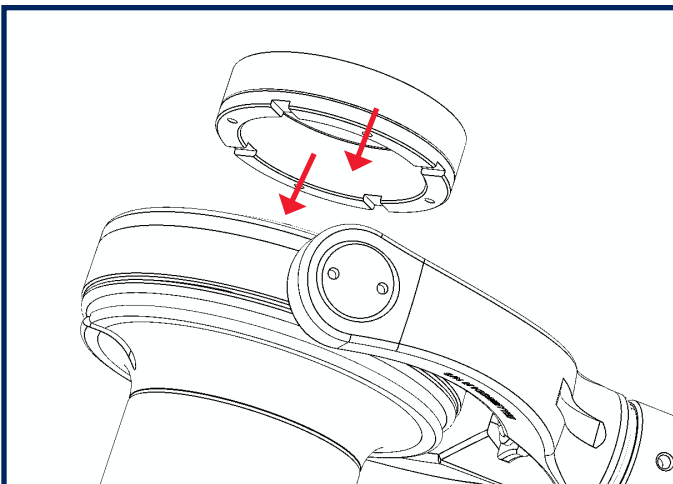

Carefully line up the two pins of the pan encoder ring with either two of the pin-wrench holes and press it onto the gimbal.

Orientation is not important.

Make sure the ring sits flush and is adhered all the way around.

# Installation

Slide the gimbal handle pulley over the gimbal handle.

Line up the lock screws with the four holes on the knurled blue ring.

Use a 0.05" Allen key to tighten the four lock screws enough to secure the pulley. Do not over-tighten.

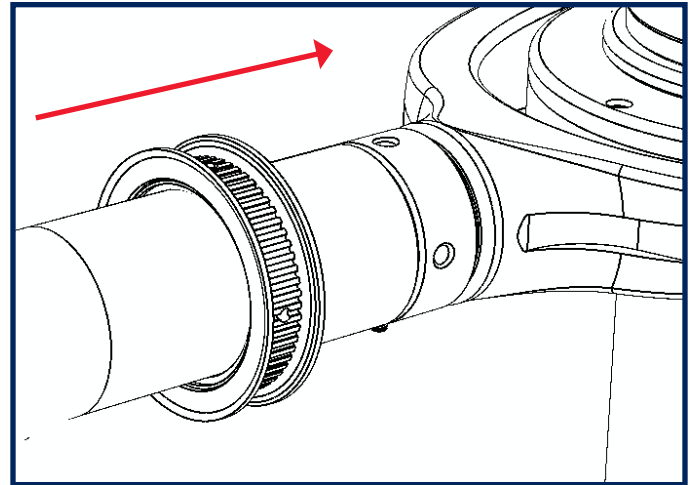

**TIP:** If you're upgrading a PRO gimbal, due to the shape of the handle, it's easier to install the handle pulley during the upgrade process.

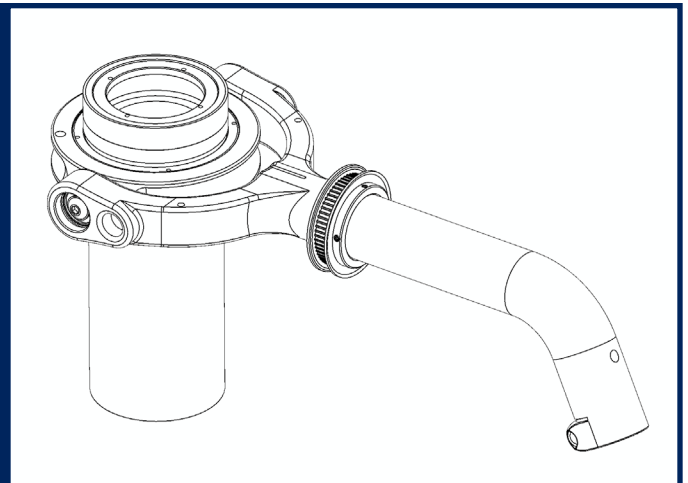

Next, if your gimbal is wearing trunnion covers, remove BOTH of them using the smallest pin set on the blue whale wrench supplied with your sled or gimbal upgrade.

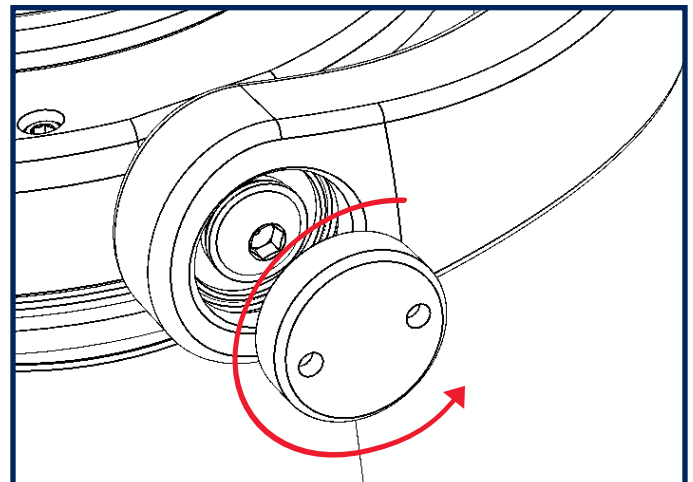

# Installation

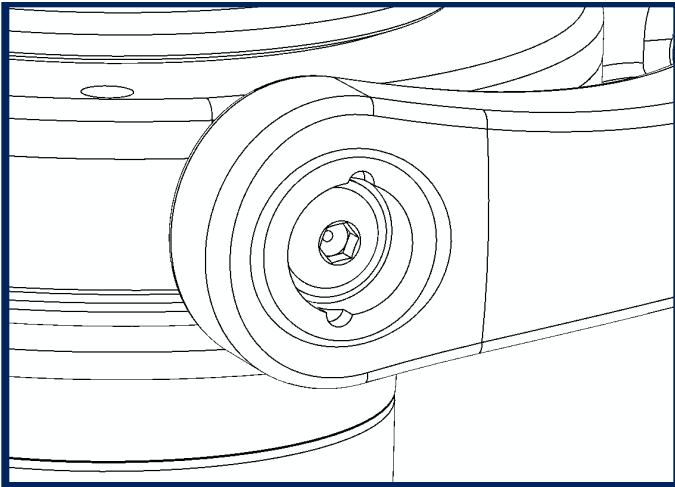

For M-1 gimbals, replace BOTH covers with the supplied threaded cap adapters using the same pins on the blue whale wrench.

Leave the trunnion screws in place.

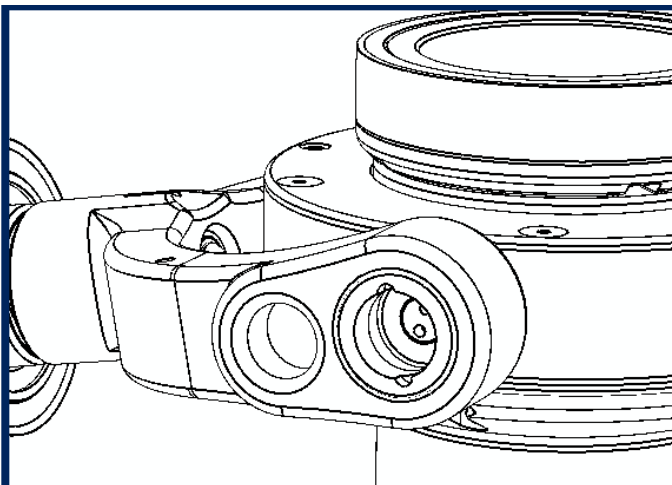

For M-2 and upgraded gimbals, install one thread adapter ONLY on the side of the gimbal where you will mount the motor assembly.

Right side shown here. If mounting Volt on the left, thread the adapter to that side.

Leave the trunnion screws in place.

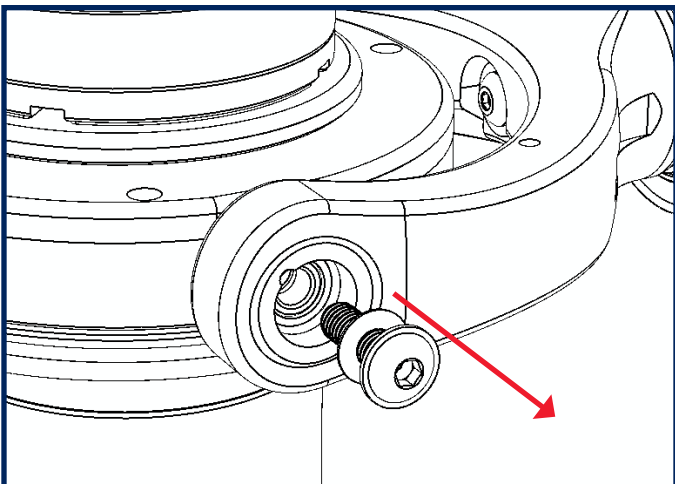

M-1 gimbals use a 1/8" Allen wrench to remove the small button screw and Belleville washer of the gimbal trunnion from the PULLEY side.

We will be re-using the washer, but set aside the screw.

Right side install shown.

# Installation

Install the trunnion pulley in place of the M-1 trunnion screw, with the washer behind it. Use the narrow pins on your blue whale wrench to tighten.

**NOTE:** The pulley should be installed as shown, with the relief around the lock screw hole facing outwards.

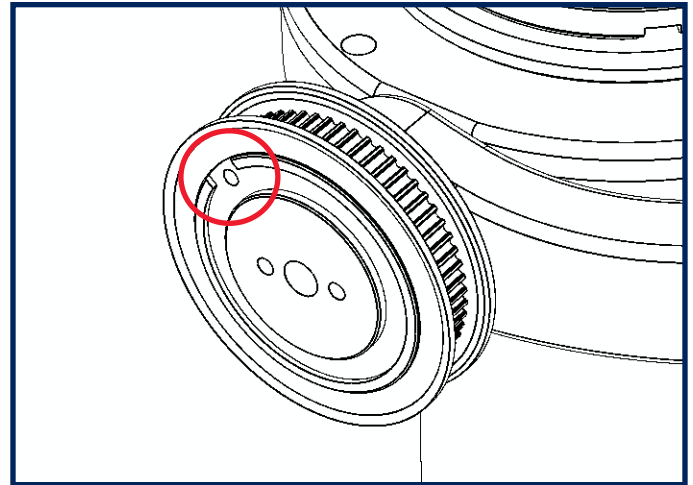

M-2 and gimbal upgrades will install the pulley with bearing OVER the trunnion screw.

The blue pin wrench is used to secure the pulley.

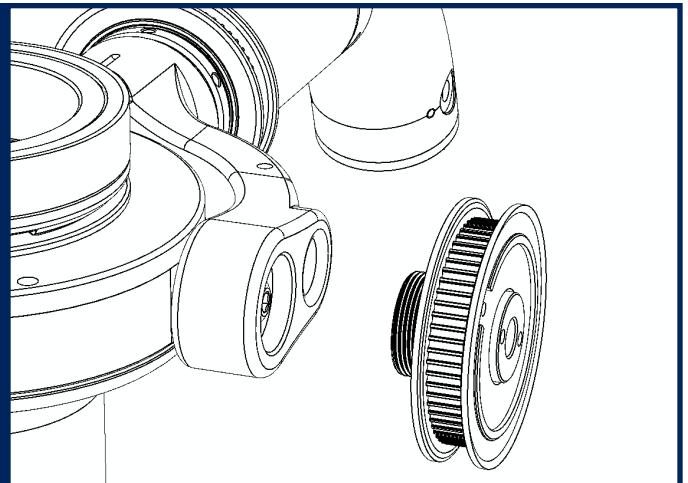

With a 5/64" Allen wrench, remove the place-holding set screws from the two holes opposite the gimbal handle.

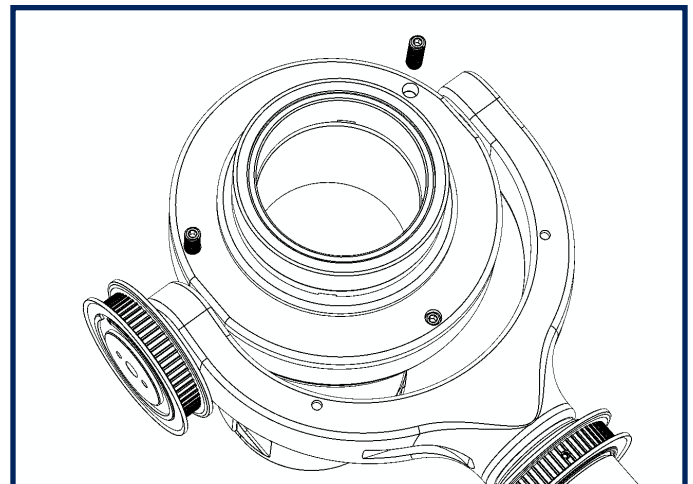

# Installation

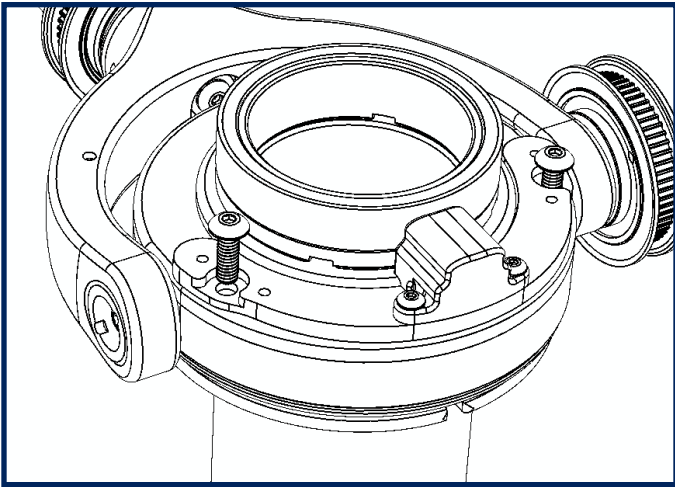

Affix the pan encoder horseshoe to the top of the gimbal, using a 3/32" Allen wrench to turn the included 3/8" long 8-32 button head screws (part SCI-B012B1230.)

Screw location may differ from illustration.

**NOTE:** The M-2 pan encoder slots into the front of the gimbal, see the M-2 manual.

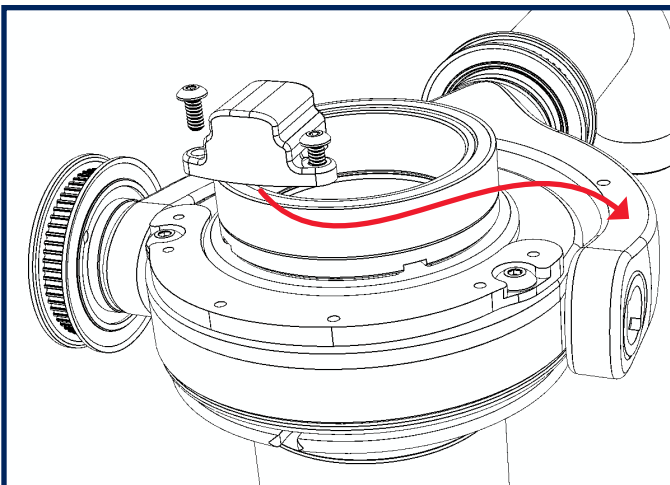

For LEFT side motor installs on M-1 or upgraded gimbals, remove the encoder from the horseshoe bracket with your 1/16" Allen key, and re-route the cable so it exits opposite the pulley side and re-attach.

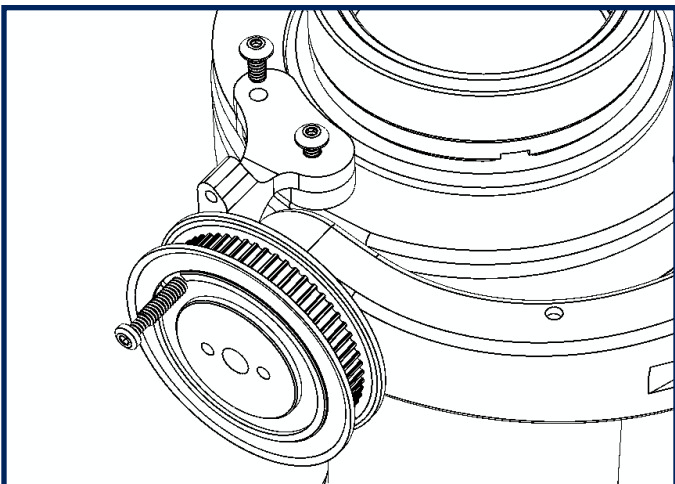

Use a 1/16" Allen key to attach the pulley lock bracket to the pulley side of the gimbal with the SHORT 4-40 screws (part SCI-4008B1230.)

Use the same wrench to lock the pulley in place using the LONG 4-40 lock screw (part 817-7958) through the lower hole in the lock bracket.

Right side install shown here.

# Installation

Before mounting the Volt motors, check that the internal wiring is properly routed and the captive trunnion screw is aligned with the housing.

**TIP:** Use a 1/8" Allen key to wiggle and turn the trunnion screw a few times to ensure it's seated in the Volt housing before mounting.

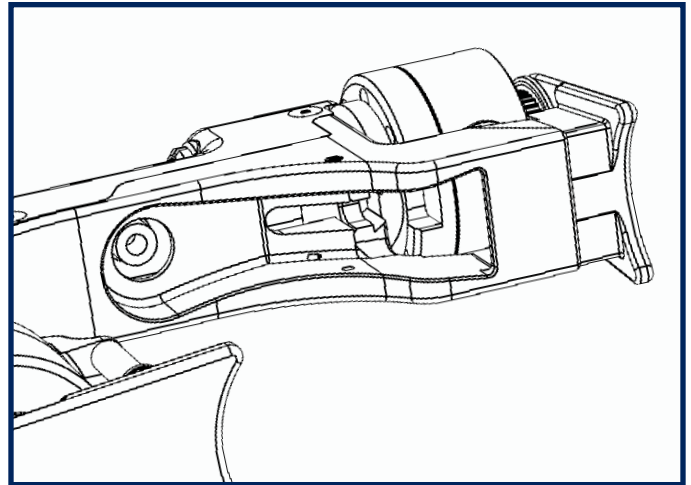

Hold the gimbal handle up slightly to enable proper clearance while installing the Volt.

Align the relief on the inside of the Volt and fit it against the gimbal.

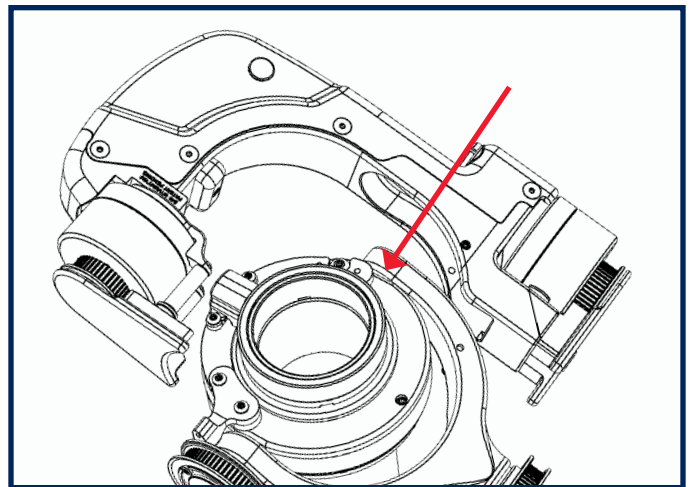

Using the 1/8" Allen key inserted through the hole in the side of the housing, tighten the trunnion screw into the threaded cap adapter.

Take your time to make sure not to cross the fine threads. Fully seat the fastener, but do not over-tighten.

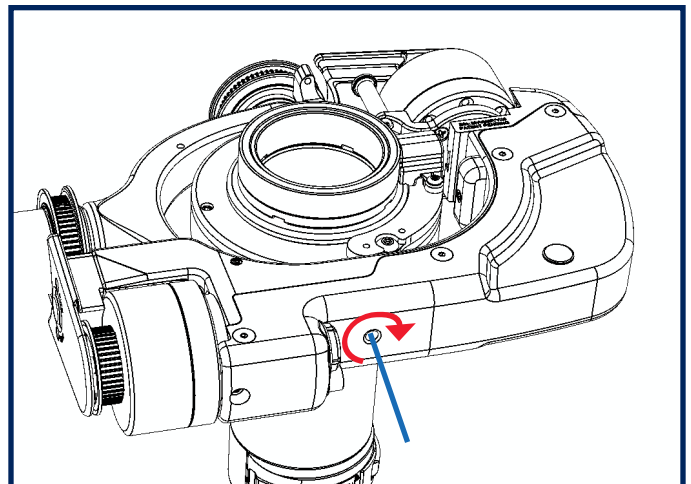

# Installation

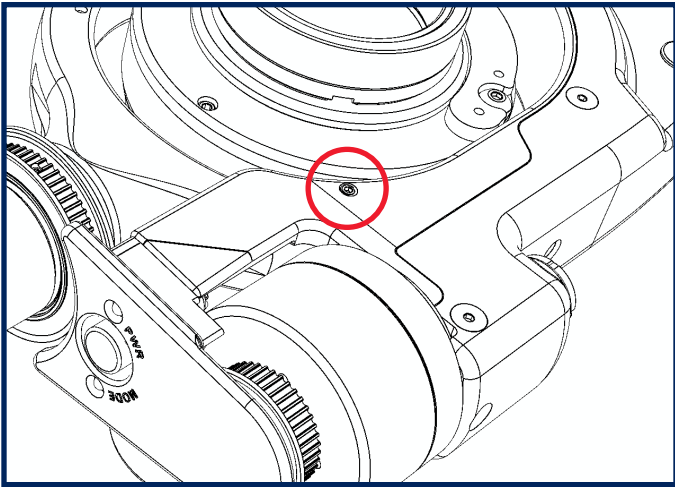

Snug the opposing pair of set screws on Volt motor assembly with a 1/16" Allen key.

There's one above and one below the yoke. Tighten them each a little until they both contact the yoke.

Do not over-tighten these!

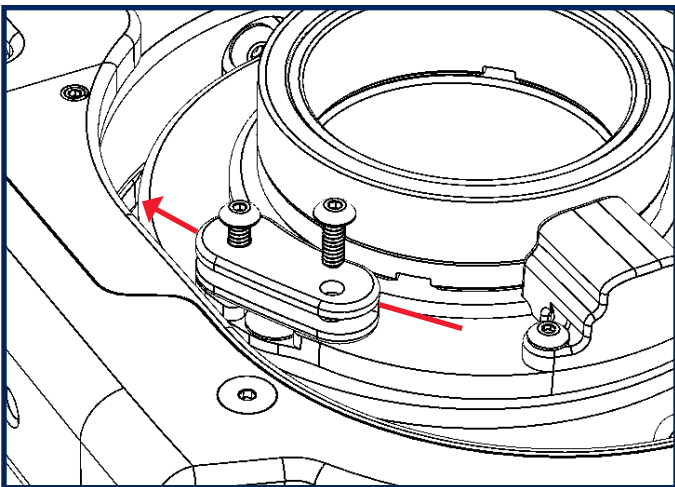

Thread the encoder cable through the guide and attach it to the horseshoe with a 1/16" Allen key and 4-40 screws (part SCI-4012B1230.)

Plug in the Hirose cable.

**NOTE:** M-2 gimbals do not require a guide, just route the cable over the Volt.

**You're almost finished!**

# Flip Button

## Important step for RIGHT mounted Volt

LEFT side mounting is default to the electronics within the Volt. But if you mount the hockey stick on the RIGHT side, you must press the invert button on the internal PC board. It's just a button press, but pay attention here.

If you mounted Volt on the LEFT side of the gimbal, skip this step and proceed to the next section. Also, if Volt arrived mounted on the right of the gimbal from the factory, this step has already been performed.

Plug in the 90° end of the gimbal cable to the control box, wrap a loop or two around the post and plug in the Volt.

The LEMO connectors rotate 90° in the control box to allow for convenient cable placement.



Make sure the pause switch is DOWN, indicating the Volt motors will not run.

Switch the power ON and the blue LEDs will illuminate.



# Flip Button

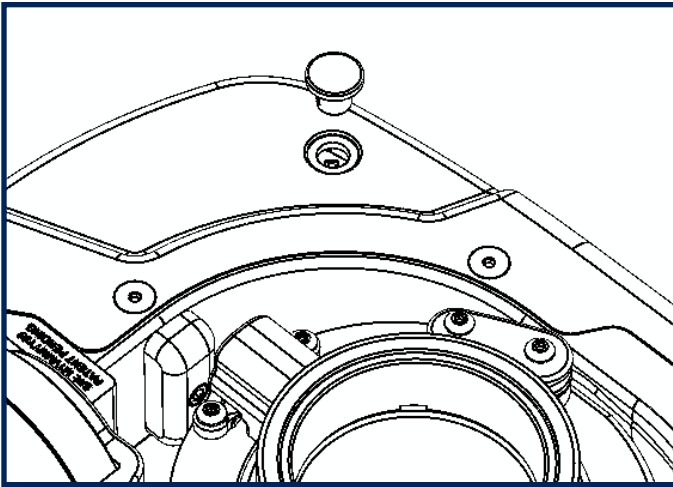

Pop out the little plastic plug from the cover.

Use a non-metallic object to carefully press and hold the invert button for 6 seconds. All LEDs will pulse off to indicate the orientation change.

Power off the unit, and the new setting is stored.

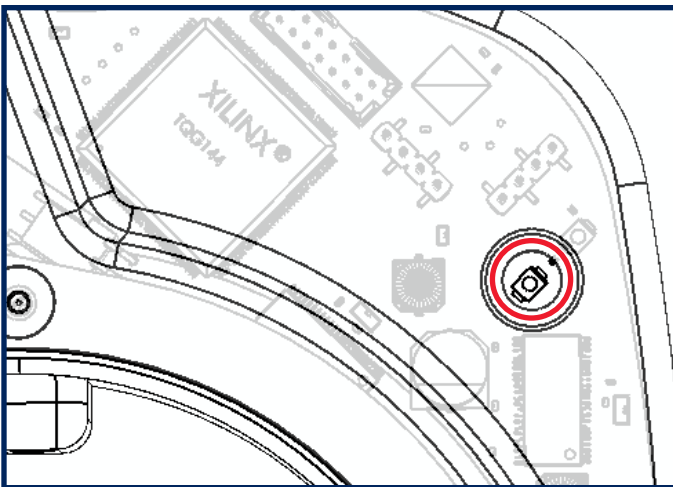

Only press it once!

Each consecutive 6-second press will toggle LEFT/RIGHT side operation.

Replace the plastic cover.

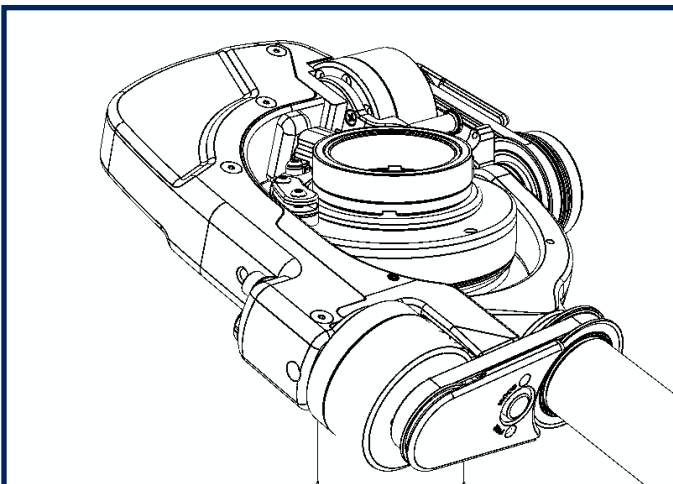

**NOTE:** If you flip your Volt to LEFT side mounting in the future, you'll have to repeat the invert button process.

# Motor belts

## Adding the belts

The two belts transfer power from the Volt motors to the gimbal yoke and gimbal handle. The belts will never stretch and should not need replacement with normal use. Installing them will take finding the right belt angle and rotation of the pulleys, but they are self-aligning once in place. Let's put on our belts!

**NOTE:** Right side build shown here; left side is a mirror image.

First, move the handle motor as close as possible to the gimbal handle by turning the belt tension screw counter-clockwise with a  $7/64$ " Allen key.

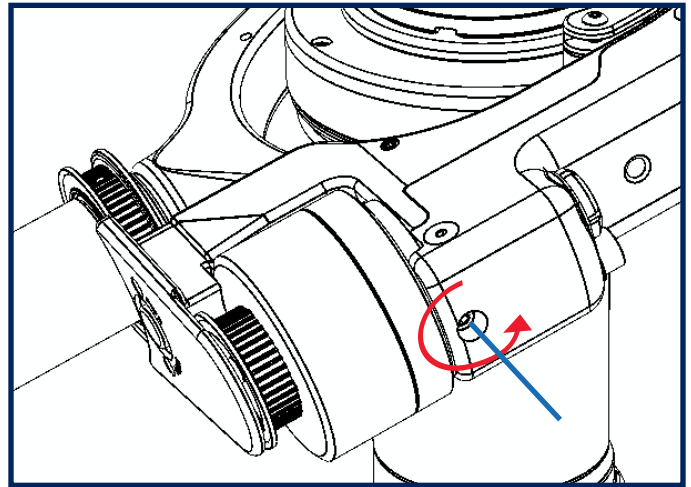

With the same Allen key, turn the trunnion motor belt tension screw counter-clockwise, to slide that motor toward the gimbal.

**TIP:** If you're installing belts with the gimbal ON the rig, stand your sled on a table so the gimbal handle is free to move during belt install.

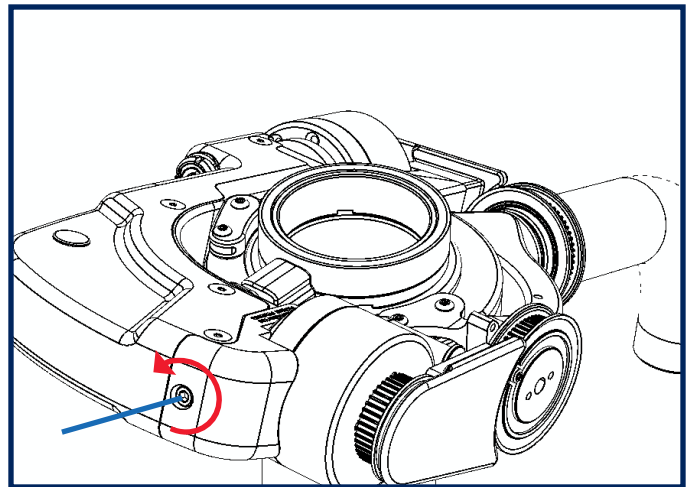

# Motor belts

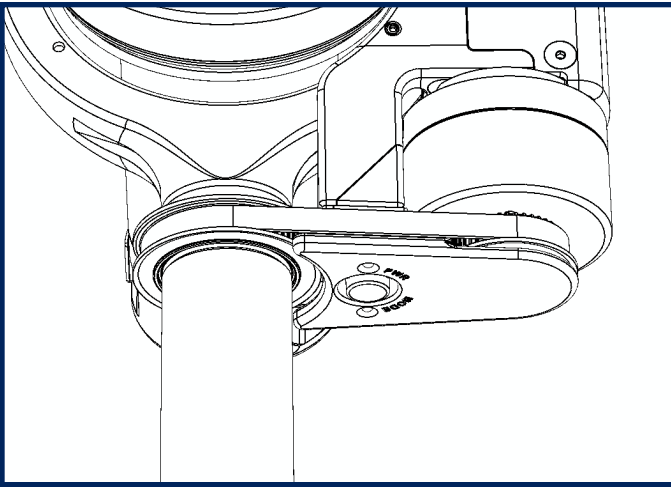

Place one of the belts (they're identical) over the handle pulley and over the top of the motor pulley.

Rotate the handle and use your fingers to walk the belt over the sidewall of the pulley.

Be careful not to get pinched!

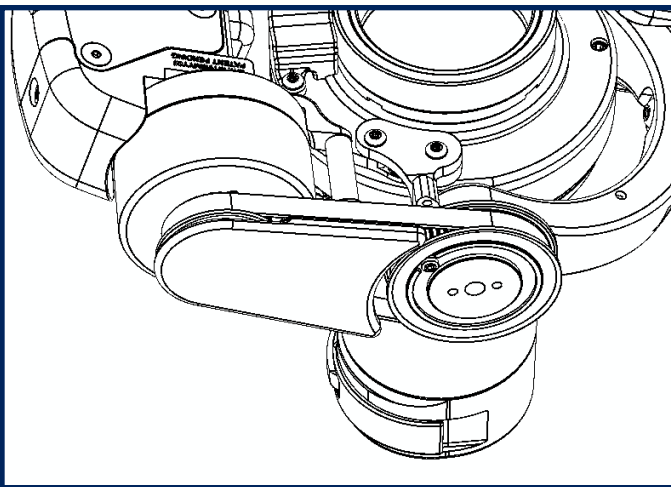

Place the other belt over the trunnion motor pulley and over the top of the trunnion pulley.

Use your fingers to walk the belt over the sidewall of the trunnion pulley.

**TIP:** If the belt is stubborn, try lifting the gimbal handle while installing the belt to help walk it onto the pulley

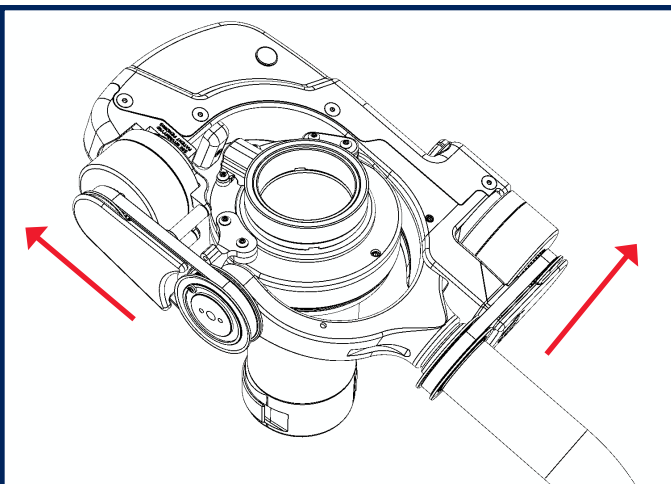

Adjust BOTH belt tensions by turning each tension screw clockwise with the 7/64" Allen key.

Slowly adjust each belt tension, a little at a time, so the Volt is loaded evenly.

To test belt tension, grasp each belt halfway between the motor and pulley with a firm pinch, and twist the belt 45 degrees. If it goes beyond 45 degrees, the belt is too loose.

# Motor belts

Precise belt tension is not required for optimal performance. The belts should not have any slack, but not be so tight as to create friction.

**NOTE:** You may wish to adjust the tension again with Volt powered on to check its behavior.

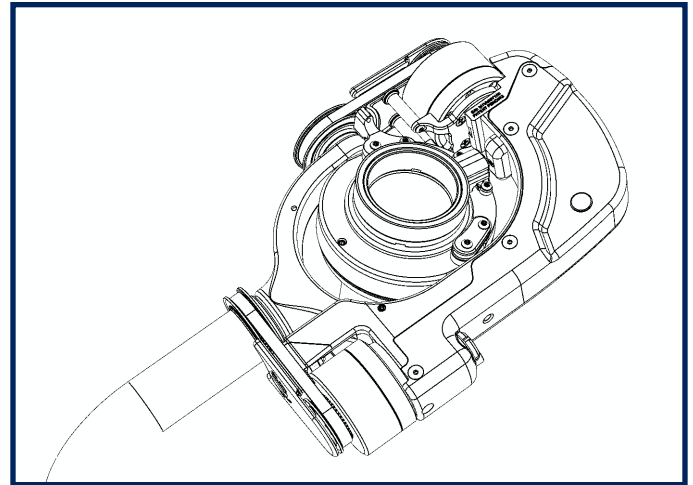

The finishing touch is to spin the trunnion weight into the 1/4-20" threads of the trunnion pulley.

Just make sure it's on tight, no need to over-torque it.

**NOTE:** M-2 trunnion weights require an Allen key to attach the weight.

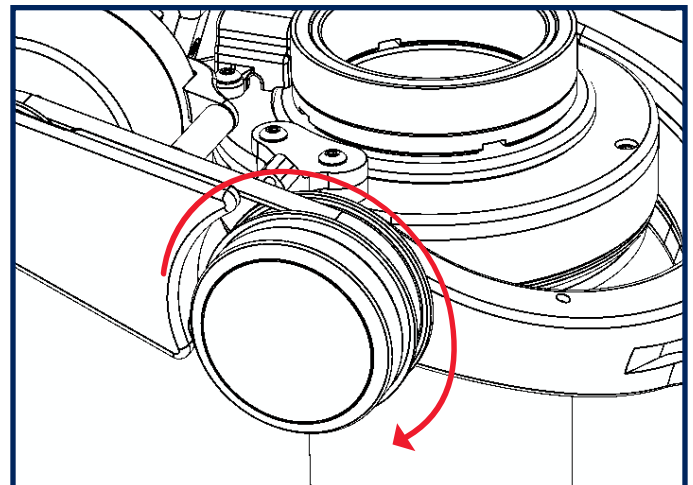

If you haven't yet, reinstall the gimbal onto the sled.

With the gimbal lock open, slide the gimbal back onto the post and re-assemble the top stage.

**TIP:** You can eliminate unnecessary docking rings from your post and gain precious gimbal height!

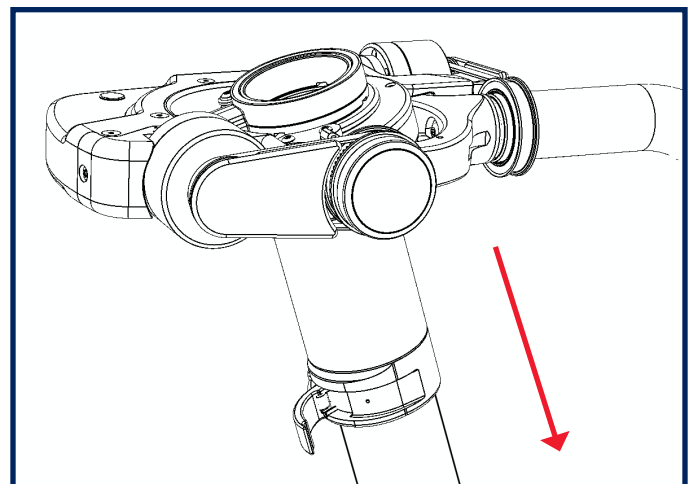

# Motor belts



Plug in the 90° end of the gimbal cable to the control box, wrap a loop or two around the post and plug in the Volt.

The LEMO connectors rotate 90° in the control box to allow for convenient cable placement.

*TIP: Depending on your normal builds, you may prefer the optional "long" gimbal cable.*

**Your Volt equipped sled should be ready for action! Now go back to page 9, and get ready to balance before powering on.**

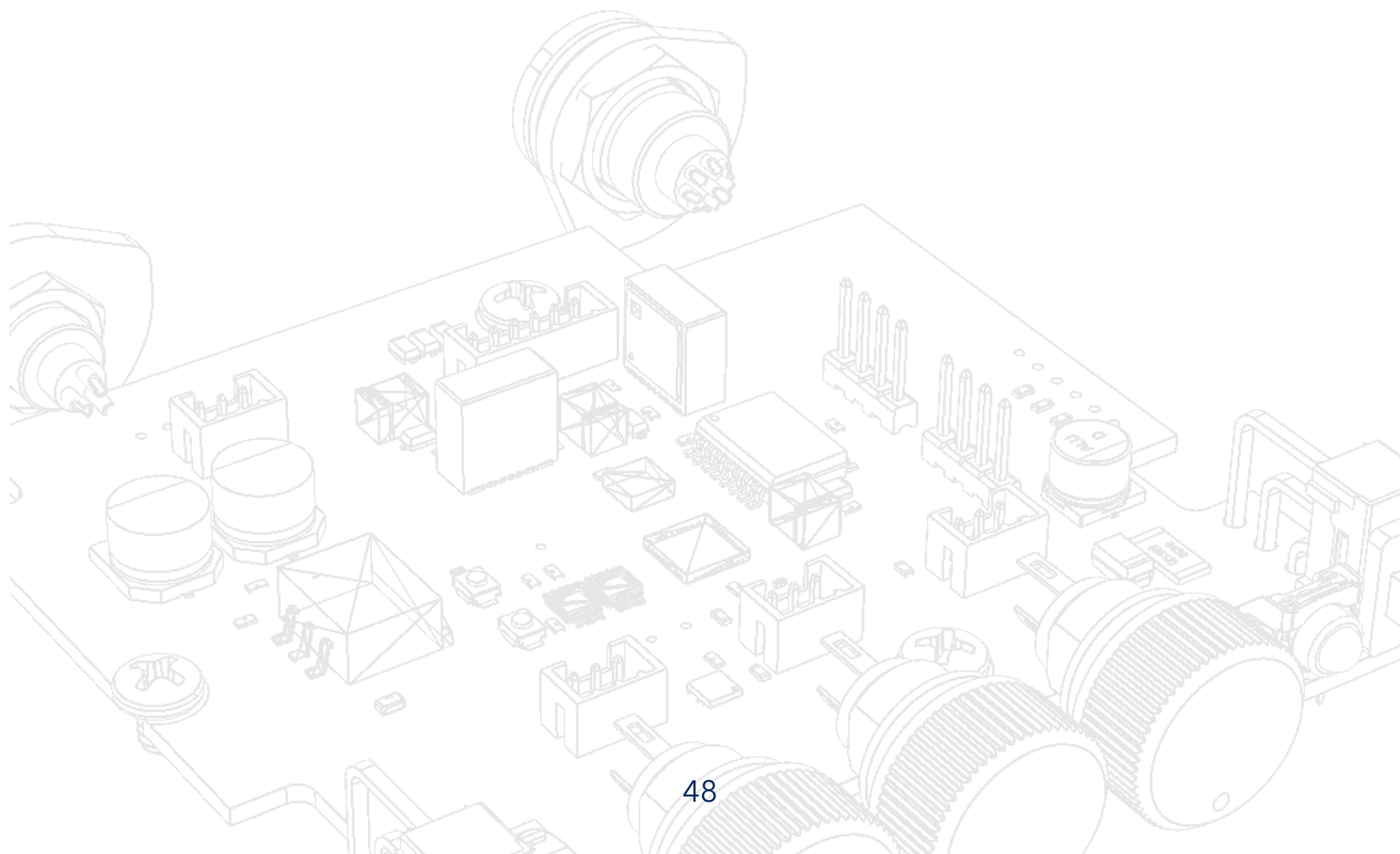

STAND



# Archer/Archer2

## Gimbal upgrade

It's recommended you have an experienced Steadicam technician do the service for you, but upgrading an Archer or Archer2 gimbal is a fairly straightforward procedure. Here are the assembly notes used by the factory for reference. Visit [tiffen.com/steadicam/voltssystem/](http://tiffen.com/steadicam/voltssystem/) for more information.

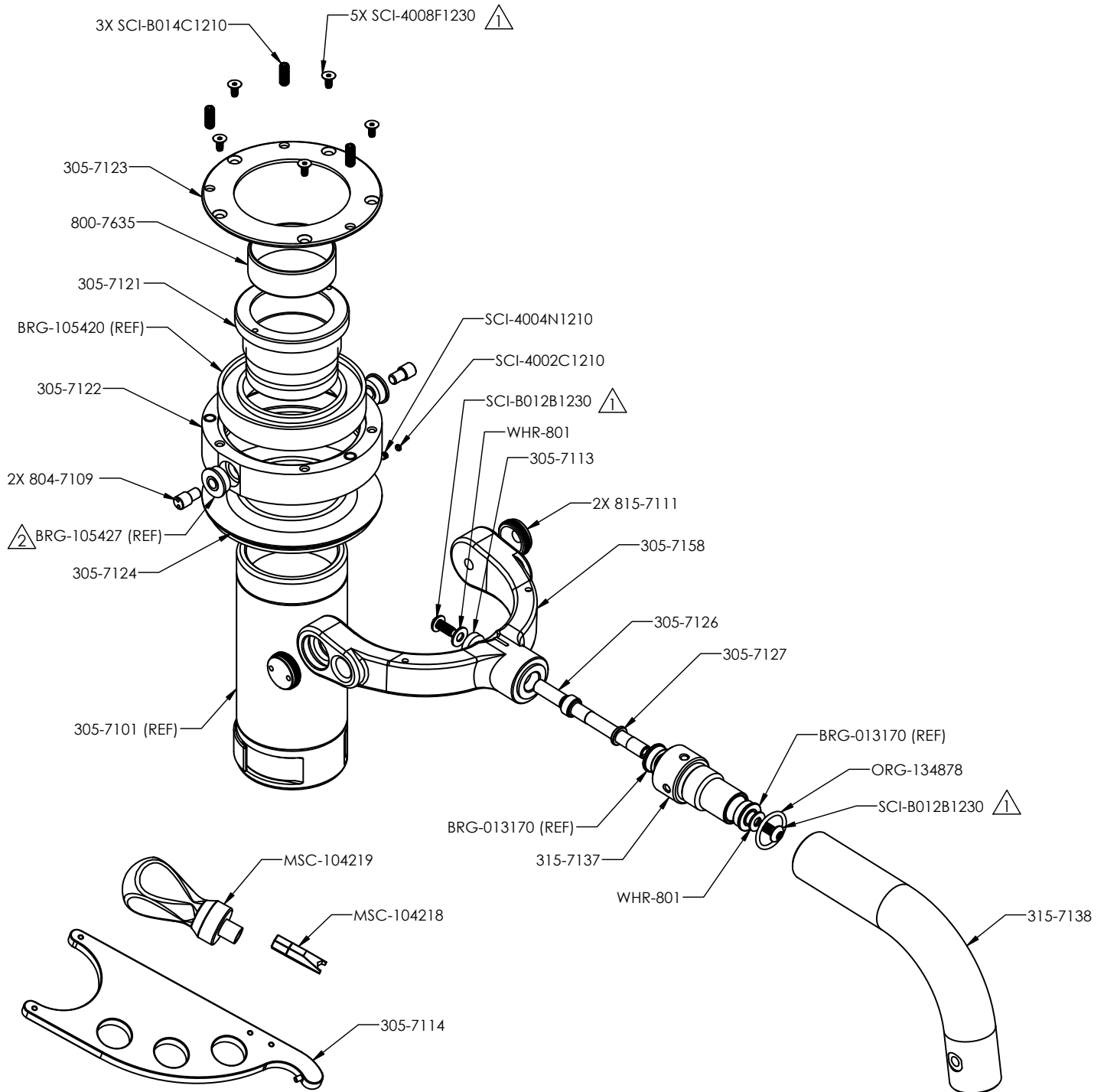

# Archer/Archer2

## Assembly procedure

1. Remove gimbal from sled and dis-assemble all parts from top bearing portion of gimbal. Be careful to not damage any parts as some will be re-used upon re-assembly.
2. Perform bearing cleaning or re-lubrication if required.
3. Press BRG-105420 into 305-7122 outer ring, carefully and evenly only on the outer race of the bearing until it is fully seated.
4. Press both BRG-105427 bearings into 305-7122 outer ring carefully and evenly only on the outer race of the bearing until they are fully seated.
5. Install 305-7124 onto 305-7101, and align screw clearance slot with screw holes in 305-7101.
6. Install and tighten SCI-4004N1210 into 305-7124 and then install and tighten SCI-4002c1210 into same hole and tighten.
7. Thread 305-7121 into 305-7101 and fully tighten with 305-7114 wrench.
8. Install 800-7635 into 305-7121.
9. Install 305-7123 onto 305-7122 using 5x SCI-4008F1230 screws and Loctite 222. Note orientation of ring with respect to 305-7122.
10. If gimbal is not being outfitted with a volt system at this time, install 3x SCI-B014C1210 into the threaded holes in 305-7122. Omit if a volt system is to be installed.
11. Note some newer archer 2 assemblies already fitted with 315-7137 and associated parts. In this case, assembly of 305-7158 yoke and associated parts are only required.
12. If an older archer gimbal is to be modified, assemble all handle components together as shown noting the use of Loctite 222 where required.
13. Install completed yoke assembly onto 305-7122 using 2x 804-7109 adjustment screws and balance gimbal as required using balance procedure and MSC-104218 spanner screwdriver bit.
14. Complete assembly by installing 2x 815-7111 caps. Omit if a volt system is to be installed.

***NOTE: Perform the Archer gimbal balancing procedure found on the next page prior to Volt installation.***

# Archer/Archer2 gimbal balancing

## Gimbal Balancing Procedures for: Archer 2 Series 305-7120-XX

1. Mount simulated camera weight (maximum payload capacity of sled recommended) onto sled and place onto appropriate balance spud.
2. Fine tune fore-aft and left-right balance by adjusting fore/aft and side/side adjustment knobs on stage. Verify balance using a bubble level attached atop the stage on a flat surface.
3. Balance sled with an approximate 3 second drop time by fine tuning vertical position of gimbal.
4. With the front of the sled facing left, and the stage perpendicular to the curved gimbal handle, raise the sled to the right to a horizontal position and release until it swings back to a vertical position.
5. Unit should always return to the established vertical position. If it does not, fine-tune the adjustment pin screws (part# 804-7109) using included MSC-104218 spacing spanner screwdriver and repeat the previous step.
6. To adjust pin screws remove bearing caps (815-7111) to access pin screws
7. Gimbal ring (305-7122) to yoke (305-7158) clearance should have zero end play but swing free, this is adjusted by turning pin screws.
8. The adjustment pin screws should have some resistance when turning.
9. If the unit is leaning to the left of vertical: turn the right adjustment screw counter-clockwise and the left adjustment screw clockwise in equal increments. If leaning right of vertical, reverse this procedure. **WARNING:** turn these screws in small increments (1/16 of turn) as it will have a magnified affect when drop time is set at 3 seconds or more.
10. Repeat drop test again. If unit does not repeat check to make sure all clamps, plates, camera and whatever else might shift or become loose is stable and not shifting the balance point.
11. Re-install bearing cap covers, if not installing Volt.

# Archer/Archer2

ITEM NO.	PART NUMBER	DESCRIPTION	QTY.
1	305-7113	WASHER, GIMBAL STOP	1
2	305-7114	ASSY, GIMBAL TOOL	1
3	305-7121	INNER RACE TUBE,	1
4	305-7122	OUTER RING, GIMBAL, ARCHER2	1
5	305-7123	FLANGE, GIMBAL	1
6	305-7124	FLANGE, GIMBAL,	1
7	305-7126	PIVOT SHAFT, GIMBAL	1
8	305-7127	WASHER, GIMBAL	1
9	305-7158	YOKE, VOLT	1
10	315-7137	HANDLE, QUICK RELEASE	1
11	315-7138	HANDLE, GIMBAL	1
12	800-7635	BRAKE, .055" WALL, .560" TK	1
13	804-7109	SCREW, GIMBAL PIVOT	2
14	815-7111	CAP, YOKE, GIMBAL	2
15	MSC-104218	DRILL SPANNER BIT, #6	1
16	MSC-104219	BIT HOLDER, 1/4" SHANK, MAGNETIC	1
17	ORG-134878	O-RING, 1/16 X 5/8 X 3/4	1
18	SCI-4002C1210	SCW, 4-40 X 1/16, SET_C HEX	1
19	SCI-4004N1210	4-40 X 1/8 SET_C HEX	1
20	SCI-4008F1230	SCW, 4-40 X 1/4 F82° HEX	5
21	SCI-B012B1230	SCW, 8-32 x 3/8 BUT HEX 18-8 SS BLK TEFLON	2
22	SCI-B014C1210	SCW, 8-32 X 7/16 SET CUP SS	3
23	WHR-801	#8 WASHER, SS	2

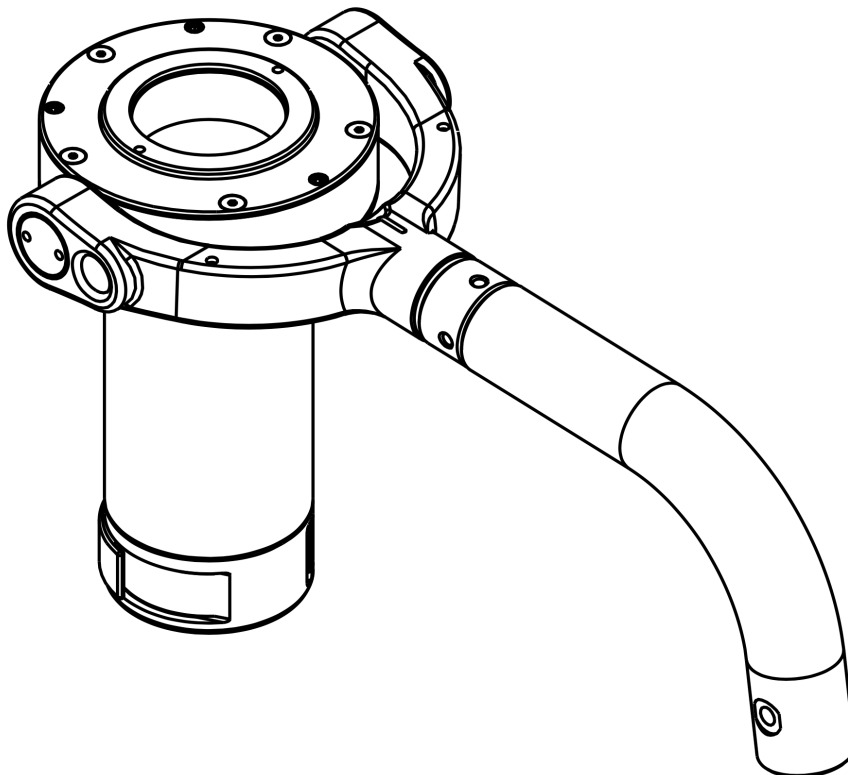

# Ultra2, Shadow, Clipper

## Gimbal upgrade

It's recommended you have an experienced Steadicam technician do the service for you, but upgrading an Ultra2 or Shadow gimbal is a fairly straightforward procedure.. Here are the assembly notes used by the factory for your reference. Visit [tiffen.com/steadicam/voltssystem/](http://tiffen.com/steadicam/voltssystem/) for more information.

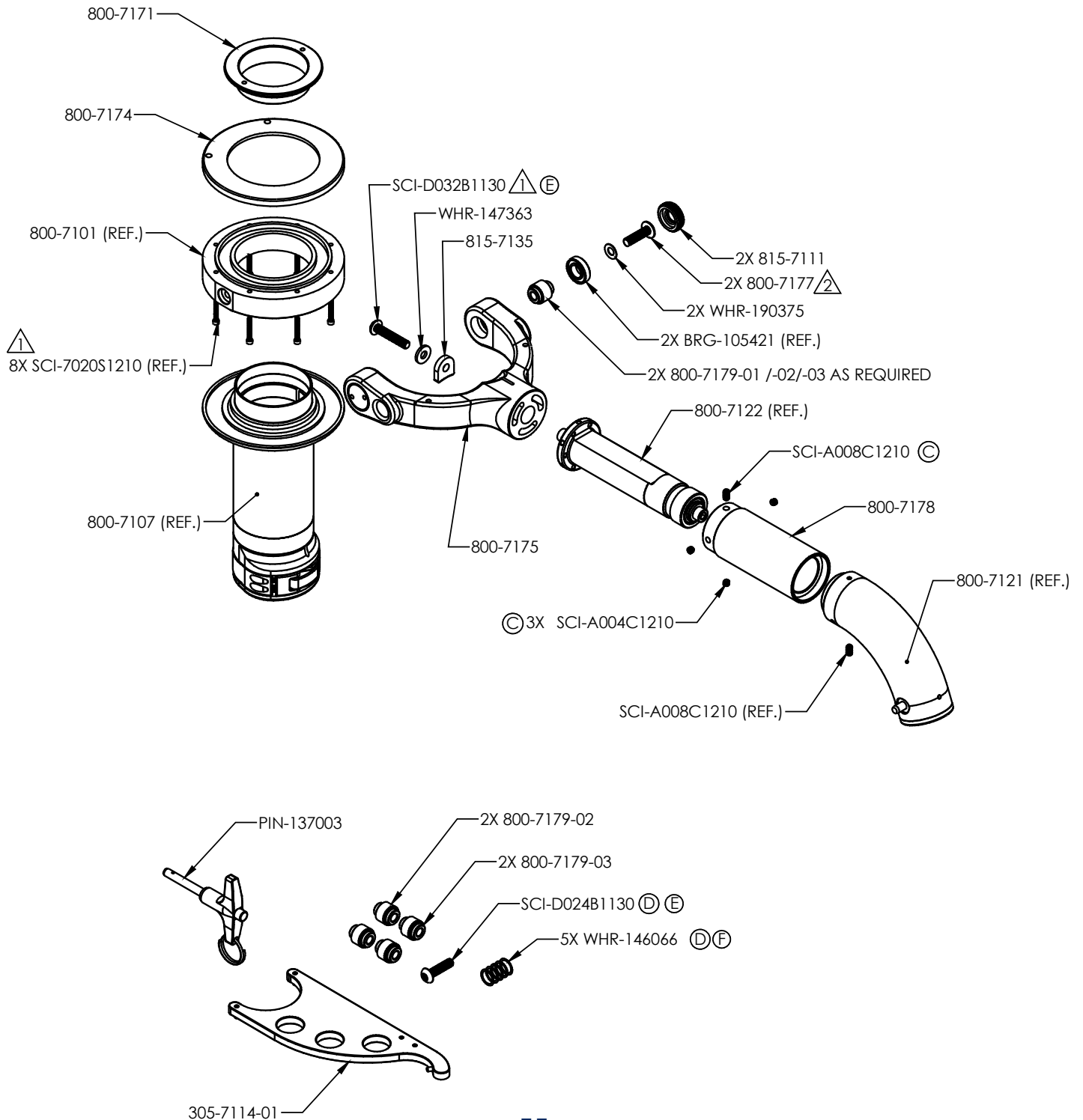

# Ultra2, Shadow, Clipper

## Assembly procedure

1. Remove gimbal from sled and dis-assemble main bearing housing from gimbal handle. Be careful to not damage any parts as some will be re-used upon re-assembly.
2. Perform bearing cleaning or re-lubrication if required.
3. Install 800-7174 on to 800-7101 using 8x SCI-7020S1210 screws and 222 Loctite. Note orientation of bearing clamp.
4. Thread 800-7171 into 800-7107 and fully tighten with 305-7114-01 wrench.
5. Disassemble yoke components and then re-assemble using new 800-7175 yoke as shown noting the use of Loctite 222 where required.
6. Remove 800-7121 sub assembly from 800-7122 by first loosening screw SCI-A008C1210.
7. Install 800-7178 or 800-7178-01 as required and re-assemble 800-7121. Note that 800-7178-01 will be used for sleds with a gimbal stage remote and 800-7178 for those sleds without.
8. Install completed yoke assembly onto 800-7107 using initially 2 x 800-7179-01 parts on either side of yoke.
9. Balance gimbal as required using balance procedure. Note that pin- 137003 is used to install and remove 800-7179-xx parts.
10. Complete assembly by installing 2x 815-7111 caps. Omit if a volt system is to be installed.

***NOTE: Perform the gimbal balancing procedure found on page 63, prior to Volt installation.***

# Ultra2, Shadow, Clipper

ITEM NO.	PART NUMBER	DESCRIPTION	800-7100-06 QTY.
1	305-7114-01	ASSY, GIMBAL TOOL	1
2	800-7171	BEARING CLAMP	1
3	800-7174	BEARING CLAMP CAP	1
4	800-7175	YOKE, VOLT	1
5	800-7177	LOCK SCREW	2
6	800-7178	HANDLE GRIP	1
7	800-7179-01	TRUNION, GIMBAL, .0000	2
8	800-7179-02	TRUNION, GIMBAL, -.0010"	2
9	800-7179-03	TRUNION, GIMBAL, +.0010"	2
10	815-7111	CAP, YOKE, GIMBAL	2
11	815-7135	WASHER, GIMBAL STOP	1
12	PIN-137003	PIN, QUICK RELEASE, 3/16"	1
14	SCI-A004C1210	SCW, 6-32 x 1/8 SET_C HEX	3
15	SCI-A008C1210	SCW, 6-32 x 1/4 SET_C HEX	1
16	SCI-D024B1130	SCW, 10-32 X 3/4 BUT HEX	1
17	SCI-D032B1130	SCW, 10-32 x 1 BUT HEX	1
18	WHR-146066	WASHER, SHIM Ø.324 X Ø.409 X .002 THK, SS	5
19	WHR-147363	WASHER, #8, .19ID .44OD .04-.07 THK. SS	1
20	WHR-190375	WASHER, .190" X .375" X .027" BELLEVILLE	2

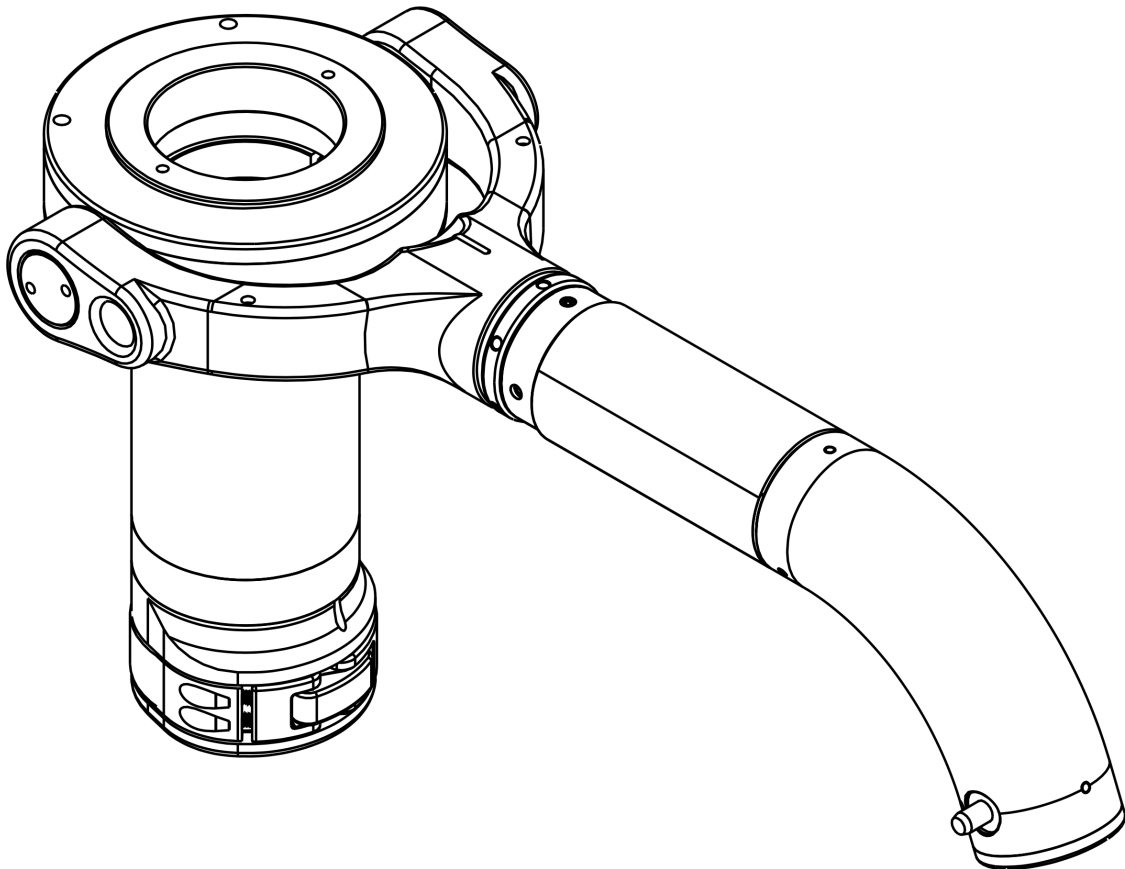

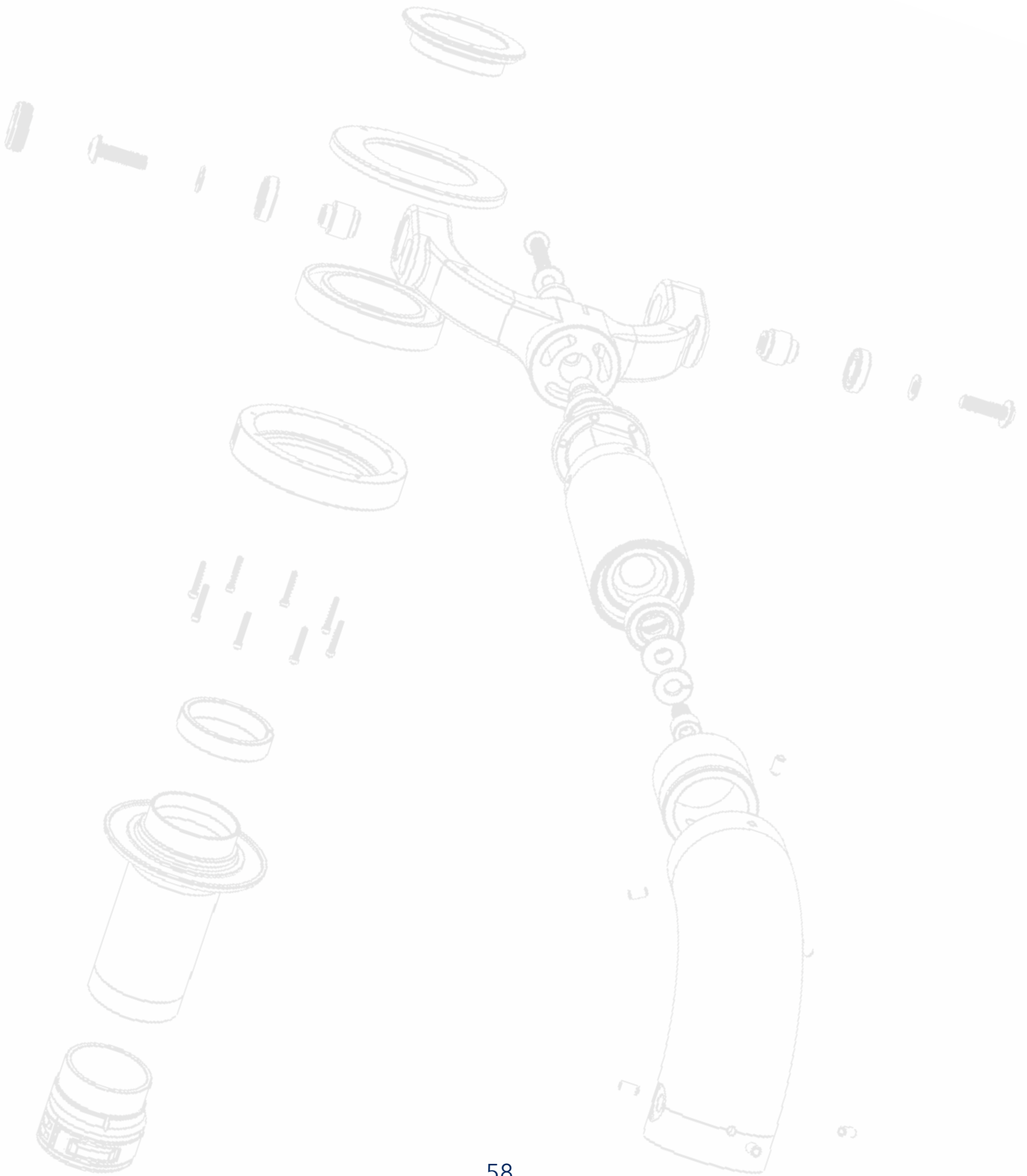

# PRO CineLive, PRO CineHD

## Gimbal upgrade

It's recommended you have an experienced Steadicam technician do the service for you, but upgrading a PRO gimbal is a fairly straightforward procedure. Here are the assembly notes used by the factory for your reference. Visit [tiffen.com/steadicam/voltsystem/](http://tiffen.com/steadicam/voltsystem/) for more information.

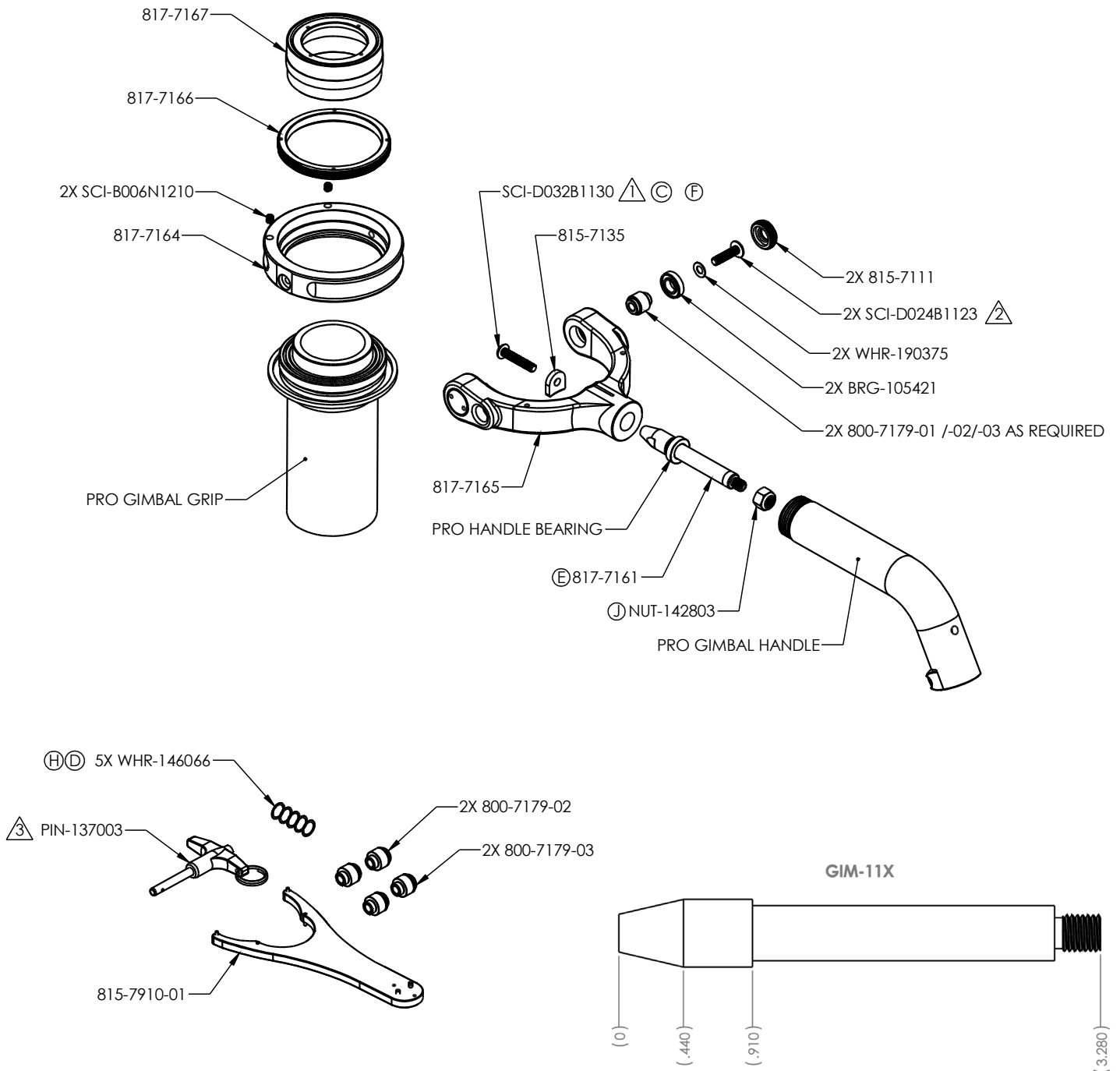

# PRO CineLive, PRO CineHD

## Assembly procedure

1. Remove PRO gimbal from sled and dis-assemble all parts from top bearing portion of gimbal. Be careful to not damage any parts as some will be re-used upon re-assembly.
2. Press PRO bearing into 817-7164 gimbal ring carefully and evenly only on the outer race of the bearing until it is fully seated. If any cleaning or re-lubrication of a used bearing is required, do it before installation.
3. Install 817-7166 bearing cap and thread on 817-7167 encoder assembly securely using 815-7910-01 spanner tool.
4. If gimbal is not being outfitted with a volt system at this time, install 2x SCI-B006N1210 into the threaded holes in 817-7164. Omit if a volt system is to be installed.
5. Disassemble pro yoke components and then re-assemble using new 817-7165 yoke as shown noting the use of Loctite 222 where required. Note that the use of latest pro gimbal axle (p/n GIM-11x) is required and is not included with the gimbal upgrade kit. Image of the correct axle is shown on page 59 for comparison.
6. If volt is to be installed at this point, first install 305-7175 pulley (not shown) onto the PRO gimbal handle before installing the handle onto the yoke.
7. Install completed yoke assembly onto 817-7164 using initially 2 x 800-7179-01 parts on either side of yoke.
8. Balance gimbal as required using balance procedure. Note that pin-137003 is used to install and remove 800-7179-xx parts.
9. Complete assembly by installing 2x 815-7111 caps. Omit if a volt system is to be installed.

***NOTE: Perform the gimbal balancing procedure found on page 63, prior to Volt installation.***

# PRO CineLive, PRO CineHD

ITEM NO.	PART NUMBER	DESCRIPTION	QTY.
1	800-7179-01	TRUNION, GIMBAL, .0000	2
2	800-7179-02	TRUNION, GIMBAL, -.0010"	2
3	800-7179-03	TRUNION, GIMBAL, +.0010"	2
4	815-7111	CAP, YOKE, GIMBAL	2
5	815-7135	WASHER, GIMBAL STOP	1
6	815-7910-01	SPANNER, PRO	1
7	817-7164	GIMBAL RING	1
8	817-7165	YOKE, VOLT	1
9	817-7166	CAP, OUTER RING, GIMBAL	1
10	817-7167	ASSY, ENCODER	1
11	BRG-105421	BEARING, 8mm x 4mm THK.	2
12	PIN-137003	PIN, QUICK RELEASE, 3/16"	1
13	SCI-B006N1210	SCW, 8-32 x 3/16 SET_C HEX	2
14	SCI-D024B1123	SCW, 10-32 x 3/4 BUT HEX	2
15	SCI-D040B1160	SCW, 10-32 x 1-1/4 BUT HEX	1
16	WHR-190375	WASHER, .190" X .375" X .027" BELLEVILLE	2

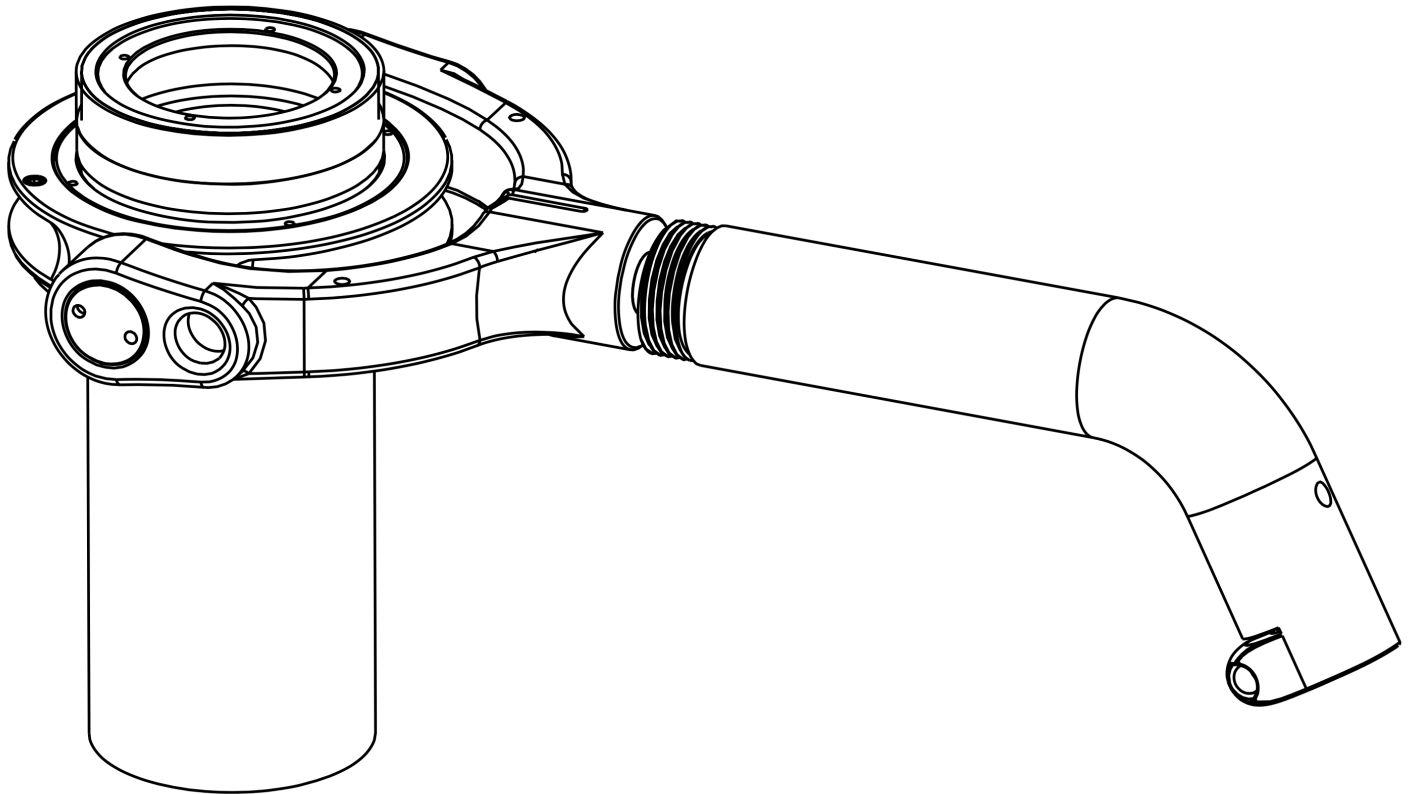

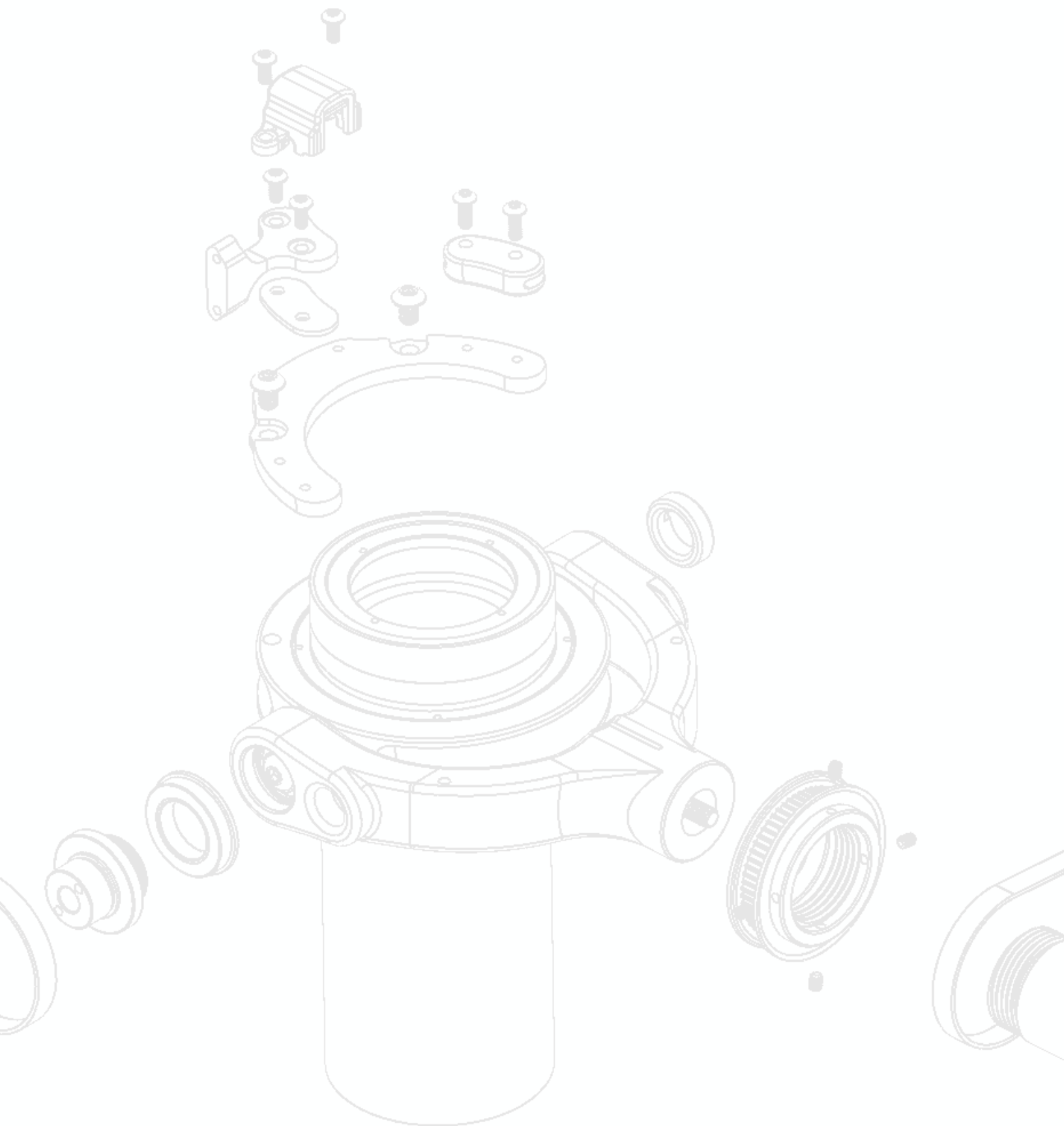

# U2, Shadow, Clipper, PRO gimbal balancing

## BALANCE PROCEDURE

1. Mount simulated camera weight (maximum payload capacity of sled recommended) onto sled and place onto appropriate balance spud.
2. Fine tune fore-aft and left-right balance by adjusting fore/aft and side/side adjustment knobs on stage. Verify balance using a bubble level attached atop the stage on a flat surface.
3. Balance sled with an approximate 3-4 second drop time by fine tuning vertical position of gimbal.
4. With the front of the sled facing left, and the stage perpendicular to the curved gimbal handle, raise the sled to the right to a horizontal position and release until it swings back to a vertical position.
5. The sled should always return to the established vertical position as noted by the bubble level. If it does not, fine-tuning of the gimbal spacers 800-7179-XX or 815-7110-XX on either side of the yoke will be required as noted in the next steps to shift the gimbal center with respect to the yoke to help achieve balance.

**a)** If after the swing test in step 4 the sled has the right side of the sled is slightly raised, this will indicate that the gimbal bearing housing will need to be shifted to the left with respect to the positioning in the yoke. (See image below with respect to gimbal orientation.)

**b)** If after the swing test in step 4 the sled has the left side of the sled is slightly raised, this will indicate that the gimbal bearing housing will need to be shifted to the right with respect to the positioning in the yoke. (See image below with respect to gimbal orientation.)

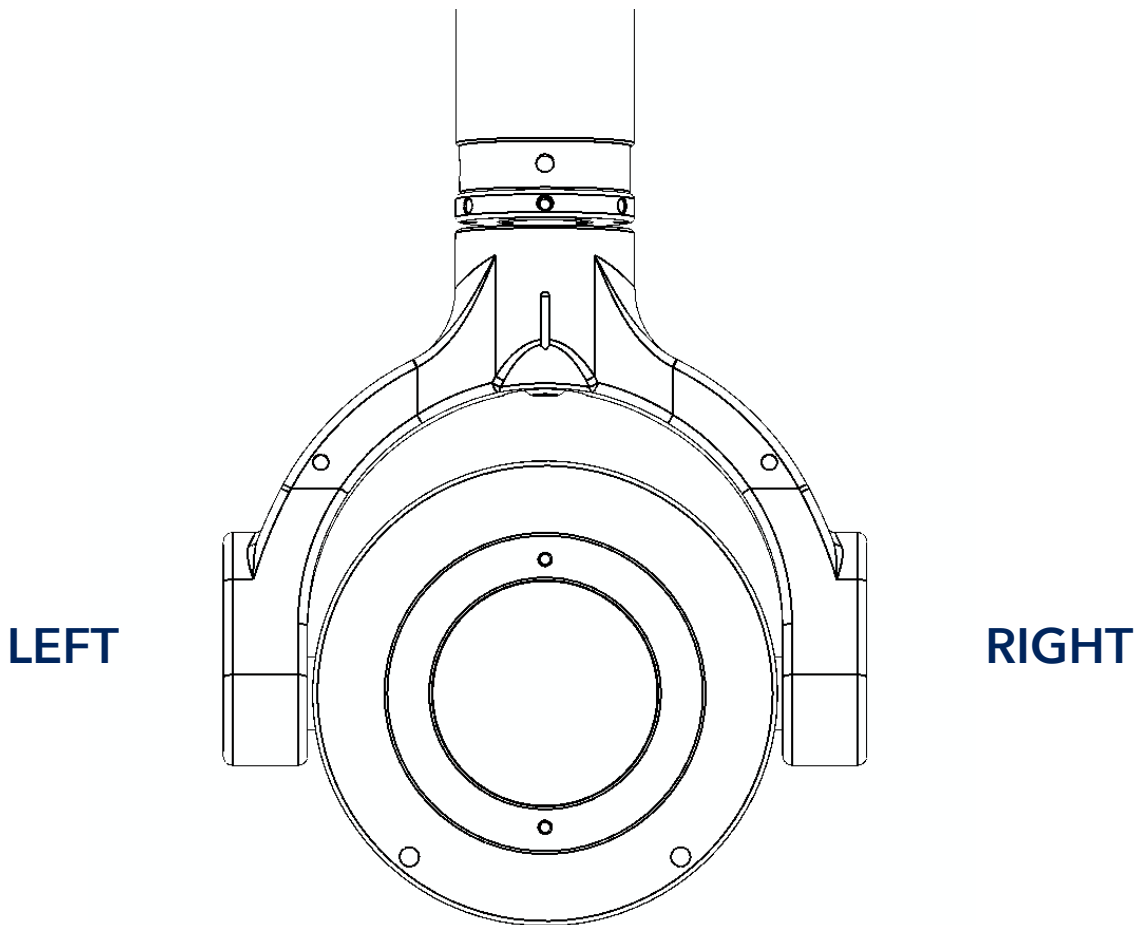

# U2, Shadow, Clipper, PRO gimbal balancing

c) NOTE that the 800-7179-xx and 815-7110-xx spacers come in three different sizes (.000", +.001" and -.001") as indicated by the grooves cut into the parts (Refer to image below). The type of spacer used will depend on the gimbal that is being balanced.

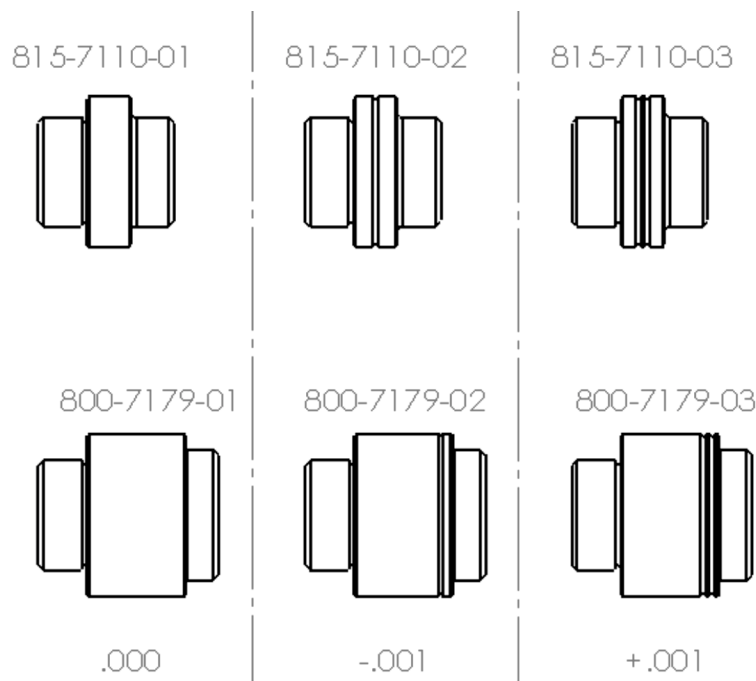

6. Dock the sled such that there is no weight applied to the gimbal.
7. Remove the 815-7111 cap from yoke using the supplied blue gimbal tool.
8. Remove the 800-7177 (10-32 screw) using a 1/8" hex key, along with washer WHR-190375.
9. In order to remove the BRG-105421 and spacer, insert 3/16" ball lock plunger (PIN-137003) into the spacer and pull out the spacer and bearing.

# U2, Shadow, Clipper, PRO gimbal balancing

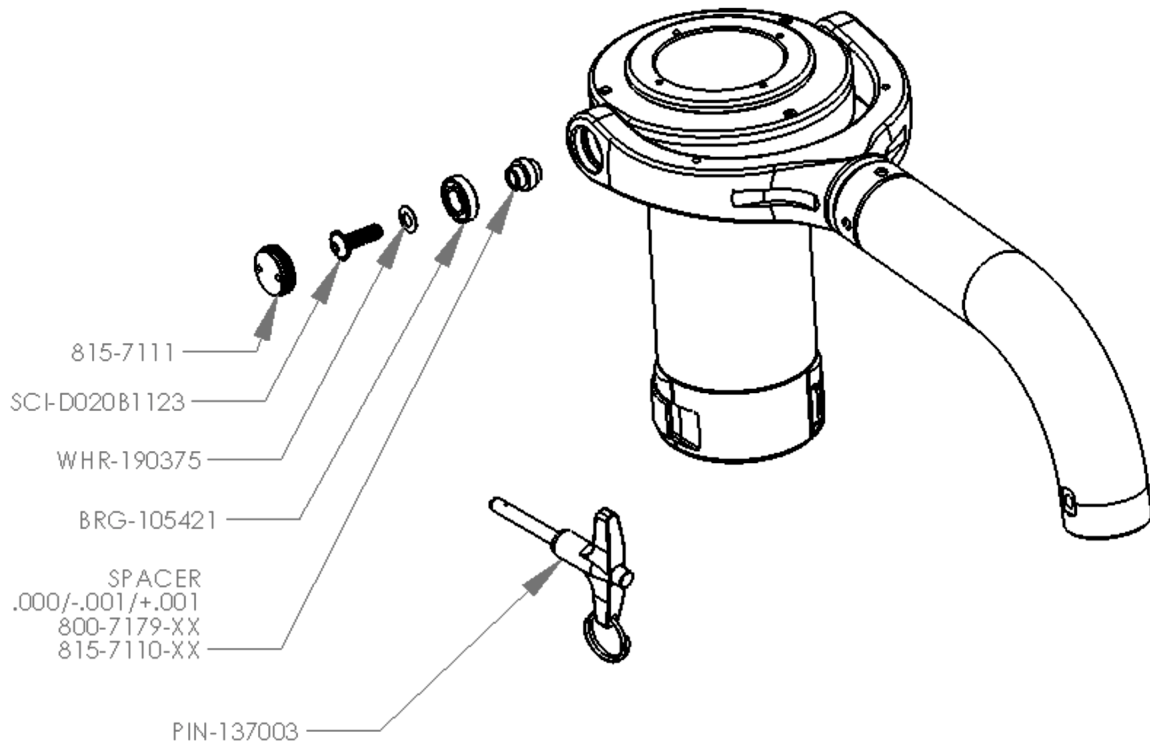

**10.** Note the type of spacer installed

**11.** If the gimbal housing bearing needs to be shifted to the left as noted in step 5a, this means that the spacer on the left side of yoke will need to be decreased (i.e. go from .000 to -.001) and the spacer on the right will need to be increased (i.e. go from .000 to +.001).

**12.** Replace spacers as required, re-assemble gimbal, verify that there is no Left - Right play in the gimbal, and repeat steps 4-11 as required until the gimbal is balanced.

**13.** NOTE that if the gimbal cannot be balanced within approximately 1-deg of accuracy, make sure all clamps, plates, camera and whatever else might shift or become loose is stable and not shifting the balance point, and re-test.

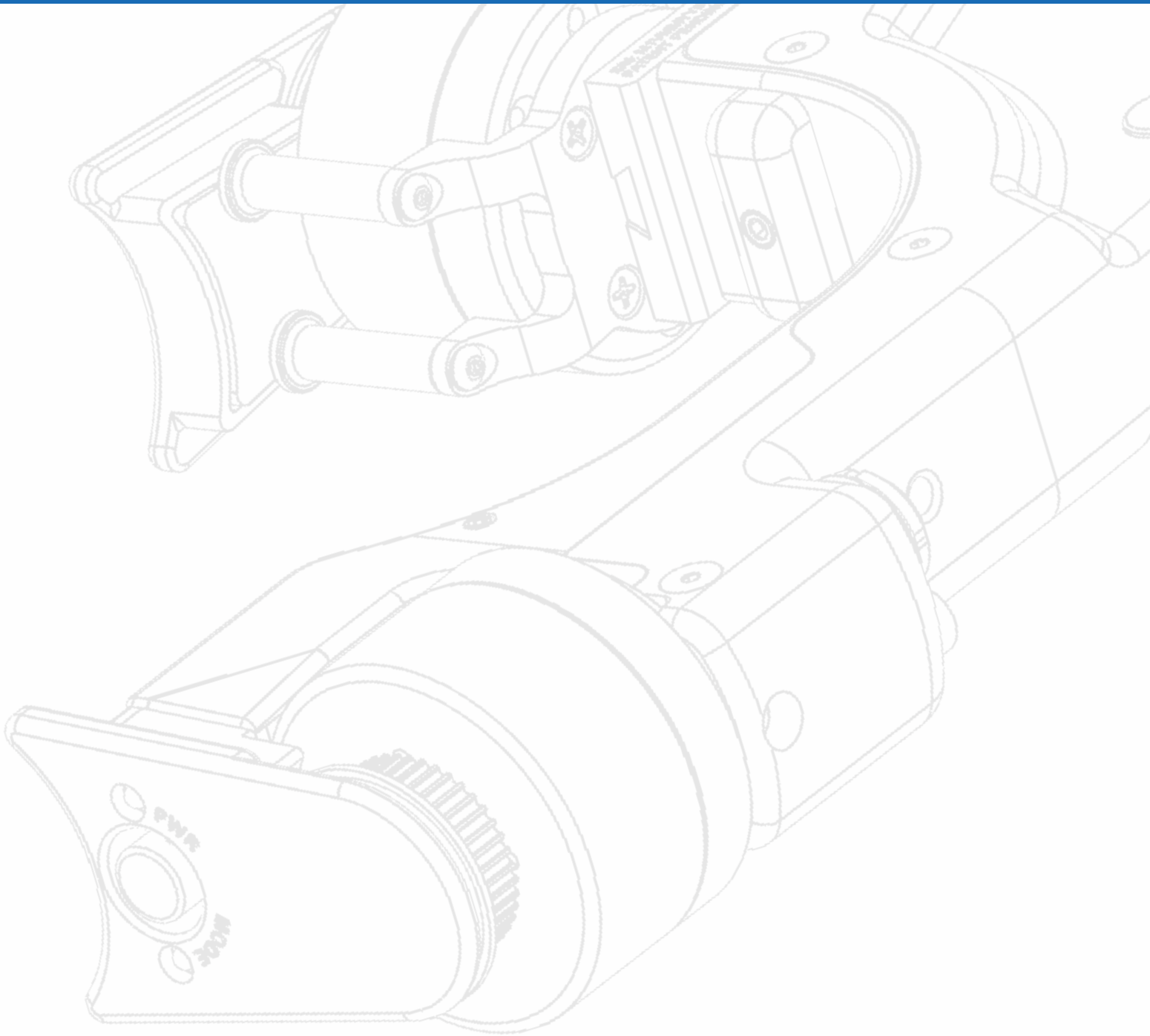

You can now fly with the upgraded yoke OR install the Steadicam™  
Volt® starting on page 35.

# Troubleshooting checklist

## If you're experiencing undesirable behaviors, first check the following:

- Is the control box receiving power? The control box will not power on without the gimbal cable attached to the motor unit.
- Is the battery voltage stable and above 12V? Volt is designed to run on 12-17V DC.
- Is the Volt motor unit receiving power? Power LEDs should illuminate on both the control box and the gimbal handle.
- Is the Volt paused? It's okay, we've all done that.
- Ensure the Volt control box is securely mounted to the stage and not shifting.
- Ensure that the Volt gimbal motor drive is securely mounted, and both belts are tight.
- Did you remember to align the gimbal handle while powering on? Control box knobs on the right, align with the rear of the post; knobs on the left, align with the front of the post. Internal Volt brain? Align the gimbal handle with the rear of the post regardless of which side the knobs are mounted.
- Did you tilt the top stage? Remember to re-balance and electronically set a new tilt trim to keep the post vertical.
- If you mounted the Volt on the right side of the gimbal, did you remember to press the "flip" switch?
- Did you convert a right-mounted hockey stick to left side, but forget to press the "flip" switch?
- Does the gimbal cable have enough slack, or is one of the cables snagged on something?
- Is the Volt gimbal cable damaged?
- Did the rig balance change? Precise, neutral balance is key to getting the most out of the Volt system.
- Did you trim for headroom with the stage knobs? That's not how we do it with Volt. Instead, leave the rig neutrally balanced, and trim for headroom electronically OR by tilting the tilt head and a new trim.
- Ensure that the Roll and Tilt controls are adjusted high enough.
- Did you remember to eat breakfast? Some say it's the most important meal of the day.
- Did the control box have time to warm up? Wait 3-4 minutes after powering up from cold before you store a new trim.
- The Volt allows such light control on the post that you may need to re-learn how to hold lock-offs. Less is truly more. More pan inertia is helpful here; move the monitor and batt's away from the post.
- We know troubleshooting can be frustrating, if none of these suggestions help, check the in-depth FAQ's on the following pages. Contact Tiffen if you require more assistance.

# Frequently asked questions: operating

## **Can I still operate with the VOLT turned off or if the VOLT fails?**

Answer: Yes, you can operate with the VOLT turned off, just make sure to remove the belts and tape down the motors so that they do not move during use. Better yet, you could also remove the VOLT all together. It's only a 5-minute process.

## **How often do I need to recalibrate?**

Answer: No periodic recalibration is needed on the VOLT unless the mounting of the VOLT Control box has physically shifted. If re-calibration is needed, SHORT-press the trim button on the control box and position the sled to the new level position while the LEDs blink for 5 seconds. When LED blinking stops, your new horizon position (or Dutch angle) is now stored in memory.

NOTE: Trim can be set independently in low mode and in high modes.

## **How do I do a factory reset?**

Answer: To reset the roll horizon to default, LONG-press the trim button on the control box for 6 seconds until both LEDs on the control box turn off and pulse back on.

## **Why does my VOLT not correct the horizon when I shoot at a Dutch angle?**

Answer: The VOLT is designed to control the roll axis of the sled up to a  $\pm 25^\circ$  roll angle, with reduced power being applied to the Roll motor beyond  $\pm 5^\circ$ .

## **What is the operating temperature range?**

Answer: recommended operating temperature of the VOLT is between  $-10^\circ$  and  $+60^\circ\text{C}$  ( $14^\circ$  to  $140^\circ\text{F}$ .)

NOTE: Lower operating temperatures may result in increasingly sluggish response times for the VOLT, so it is a good idea to let the VOLT warm up for a few minutes before operating in cold temperatures.

## **How much time does the Volt need to transition from high to low mode?**

Answer: The normal response time for the VOLT to obtain a stable level when transitioning between high and low modes is dependent on the operating temperature and a few other factors. This is normal and should take the VOLT a maximum of 20-seconds or less to stabilize.

NOTE: Low TILT and ROLL strength settings may increase the time it takes the VOLT to obtain level as more motor power equates to a faster response. In addition, a rig that is not neutrally balanced may take longer to achieve level because the motors now need to work harder to move the sled.

## **Will I be able to update the VOLT myself in the future?**

Answer: Software updates are currently limited to our worldwide dealer network and Steadicam repair facilities. Please contact your nearest dealer for information on the latest updates.

Continued

# FAQ's: operating and balancing

## **Why does the mode LED blink rapidly when I move the control box?**

Answer: The LEDs on the gimbal and control box flash rapidly on startup indicating normal operation, resetting to zero. However, if you rotate the control box faster than 300°/sec, the gyro sensors can't measure beyond that, so they perform a reset to prevent a long processing delay. Luckily, when the control box is attached to a rig, rotations exceeding 300°/sec are extremely unlikely.

## **Is the VOLT weatherproof?**

Answer: If the VOLT is being exposed to water or other contaminants, it is always good to protect it as much as possible.

NOTE: A VOLT Rain Cover for the drive unit is available to help protect the VOLT. Please contact your Steadicam representative and ask for part number "VOLTRC".

## **How do I clean the VOLT?**

Answer: Simply just wipe it down with a damp, lint-free cloth. A small brush can be used to get into any tight to reach places. Avoid any use of cleaning fluids or oils.

## **Balancing FAQ's**

### **Why is the gimbal unbalanced with the VOLT fitted?**

Answer: Center balancing of the gimbal is a very precise procedure that requires calibration of the gimbal to within the thickness of a human hair or less. A gimbal with a VOLT fitted is difficult to center balance to this level of precision, nor is it necessary. The good news is that with the VOLT turned on and operating, a slightly out of balance or slightly un-dynamically balanced sled will have little to no effect on the operation.

NOTE: The balance weight that is installed on the pulley side of the VOLT Motor Drive is used to help put the gimbal into static balance with a VOLT installed.

### **Why do I need to have neutral balance?**

Answer: Two things: One, when a sled is neutrally balanced, it requires very little force for the sled to be moved in any direction. This allows the VOLT motors to move the sled with very little applied force. This translates into quicker response times for the VOLT and a smaller power draw by the motors to adjust the sled position. Two, a neutrally balanced sled does not pendulate as it is accelerated or decelerated. Therefore, the VOLT motors have even less work to do to hold the sled at the right attitude as the sled moves and stops.

### **Why do I need to dynamic balance?**

Answer: A sled in dynamic balance pans flat without any input from the operator or the VOLT. The less work the VOLT motors must do, the better the response and the lower the power draw. Faster pans, and whip pans in particular, generate a lot of force. The better the dynamic balance, the less compensating force needs to be applied by the operator or the motors.

# FAQ's: problems

## How tight should the belts be?

Answer: To check belt tension, grasp the belt halfway between the motor and pulley with a firm pinch, and twist the belt 45-deg. If it goes beyond 45-deg the belt is too loose. However, precise belt tension is not critical for operation.

## I feel friction when I'm panning, what could be causing that?

Answer: For VOLT units fitted to M-1, Archer, Shadow or other manufacturer gimbals, ensure that the VOLT pan encoder is spaced the thickness of a folded piece of paper away from the magnetic encoder ring, as it may be making contact. For M-2 VOLT units, ensure that encoder mounting screws or the 2 x set screws filling unused pulley position mounting holes are not excessively tight, as they may be causing a slight deformation of the gimbal bearing and adding drag. Also ensure that the pulley mounting bracket is secure. If these quick steps do not help, a gimbal or gimbal bearing service may be required.

## How do I tighten the top gimbal ring or encoder ring?

Answer: For M-1, Archer, Shadow and PRO sleds, the magnetic encoder ring will first need to be gently pried up with a small flathead screwdriver. Once the encoder is lifted, the supplied Blue Whale tool or spanner wrench can be used to tighten the gimbal top ring. The magnetic encoder ring can then be re-mounted to the top gimbal ring. Be sure to align the index pins to the spanner holes before firmly pressing it down.

NOTE: Cleaning of the top ring surface with isopropyl alcohol will help with adhesion of the encoder to the ring, just keep it out of the bearings. The encoder ring's orientation is not important.

NOTE: Check to see that the VOLT pan encoder is spaced the thickness of a folded piece of paper away from the magnetic encoder ring also after installation to avoid any potential gimbal friction.

## Why is my rig vibrating or making a digital grinding noise?

Answer: When the VOLT is operating, vibration of the sled is typically caused by:

- VOLT Control Box not being rigidly attached to the stage.
- TILT or ROLL gain adjustments have been set too high.
- Tilt and/or Roll pulley mounting screws are loose
- VOLT motor drive is loose on the gimbal yoke.
- Gimbal handle is loose or belts are too loose.
- Vibration from loose monitor/batteries/accessories/camera or components mounted on the sled.

Any small vibration from a loose component on the sled has the potential of sending vibrations back to the VOLT, causing it to try and correct for the slight weight shift of the component. Avoid mounting components to the Control Box if possible as this may be introducing vibration into the system.

## Why does my VOLT vibrate when in sticky mode?

Answer: Vibrations of the VOLT at high TILT strength settings are currently a limitation of the VOLT. To solve the issue, simply reduce the motor strength of the TILT.

Continued

# FAQ's: problems

## **Why does the VOLT vibrate when turning up power beyond 50% - resonance from control box?**

Answer: Not all sleds will vibrate when the power is turned up. It all depends on the payload weight and mass/rigidity of the sled and secure mounting of the VOLT Control box. If a light camera weight and a lightweight rig are being used, a high TILT or ROLL setting may cause the motors to be too strong for the setup. This may cause the VOLT to overshoot the amount of correction it needs to apply to stabilize the sled, resulting in vibration. Also, for those sleds other than the M-2, if the VOLT Control box is not rigidly mounted to the stage, vibration can be introduced into the box which will result in vibration of the motors.

## **Why is my rig swinging (fish bowling) all over the place?**

Answer: There are 2 typical causes for a seemingly uncontrollable sled.

(a) The GOOFY/NORMAL setting of the VOLT motor drive has not been properly set. This can be corrected by powering up the VOLT in PAUSE mode, removing the plastic plug in the Motor Drive unit, and using a small plastic or wooden object, depress the pushbutton just under the plug and holding it until the LED inside the Motor Drive starts to blink at a different rate (for about 6 seconds). Holding the button down for any less than 6-seconds will result in the setting not being maintained in memory.

(b) The pan encoder is unplugged or defective.

## **Bad Pan Encoder? How to test for a bad sensor?**

Answer: Power up the VOLT normally and lock in a tilt angle without panning the sled. Next, pan the sled left or right 90°. If the tilt angle remains unchanged and the sled is operating normally, the Pan Encoder is OK. Otherwise replace the encoder or contact your service center for assistance.

## **Why do I see the rig pan left and right when I am at a lock off?**

Answer: The VOLT is a system that only controls 2 of the 3-primary rotational axes of movement: Tilt and Roll. The Pan axis is still in full control of the operator and governed by inertial mass of the sled. This axis is not compensated for or controlled by the VOLT so it may tend to drift while operating. To help combat this, the inertial mass of the sled can be increased by moving the battery and monitor masses further out. This will result in added stability and reduction of unwanted left-right panning of the sled.

## **Why is the rig panning when I tilt?**

Answer: Since the VOLT is only in control of the tilt and roll axis and not the pan axis, this axis is free to rotate. Any slight left-right imbalance or shift of balance when tilting of the sled will cause it to pan left or right. Fortunately, this artifact can be overcome or nulled out by simply adjusting the stage balance left or right until the sled does not pan anymore. The addition of more pan inertia on the sled will also help by spreading out the battery and monitor rods to full extension.

## **Why is the VOLT less effective with a "close/tight" build - monitor and batteries close to post?**

Answer: The VOLT system relies on pan inertia of the sled to maintain pan stability. Tightly built rigs sometimes will not have enough pan inertia to adequately compensate for rotation of this axis.

## **I need to dynamically operate for fast adjustments for headroom. Does Tilt affect Roll?**

Answer: No, once the rig pan angle has been set at power-up, the TILT and ROLL controls adjust motor feedback directly aligned with the camera's tilt and roll axes, independent of the pan orientation.

# FAQ's: problems

## **Why is my horizon drifting or VOLT not maintaining a horizon or tilt??**

Answer: Typically, this can be attributed to the tilt and/or roll pulley mounting screws being loose, VOLT motor drive is loose on the gimbal yoke, gimbal handle is loose, belts are loose, or VOLT Control box is loose. If the problem persists after checking all these items, contact your nearest service center for assistance.

## **Why does my VOLT not hold level when switching to low mode?**

Answer: The VOLT has independent settings for level in low mode and in high mode. This has been implemented to help compensate for VOLT units that are not mounted 100% level with the dovetail plate. Also, when switching from low to high modes, or vice-versa, allow approximately 20-seconds for the horizon to stabilize.

NOTE: If horizon re-calibration is needed, SHORT-press the trim button on the control box and hold the sled in the new level position while the LEDs blink for 5 seconds. When LED blinking stops, your new horizon position is now stored in memory. To set for low mode, simply invert the sled and repeat the above process.

## **When turning on the VOLT, the LED's turn on, then fade off. What is wrong?**

Answer: The most likely cause is low battery voltage. The batteries need to be changed.

## **Control box has the blue LED lit, but none are lit on the Drive unit. What is wrong?**

Answer: There are a few things that can be checked before calling for service:

Is the battery voltage stable and above 12V?

The Control Box or VOLT PCB may be damaged.

The VOLT cable may be damaged.

The Motor Drive may be damaged.

## **Why do the LED's on my motor drive go off and on and the VOLT operate erratically?**

Answer: The VOLT is designed to operate from 12Vdc to 17Vdc. Any voltage below 12V will start to affect the motor power of the VOLT and its ability to operate reliably. If the applied voltage to the VOLT drops too low, motor systems will be turned off. The LED's on the motor drive will go off, but LED's on Control Box may stay on. Once the voltage to the VOLT recovers to a sufficient level, motor power will automatically be turned on again. The best way to overcome this issue is to ensure fresh batteries are being used with the VOLT, or for those setups that require a heavy power draw, accessory power cables can be used for the VOLT that will connect it to an independent battery via a D-tap connector.

## **When I use certain cameras that have a high current drain why does the Volt vibrate and then start swinging around?**

Answer: Most likely the camera is robbing power from the batteries and the VOLT cannot get enough voltage to operate properly. The solution on a 12V rig is to set the batteries to parallel, use a third battery mount, or use a dedicated battery to power the VOLT.

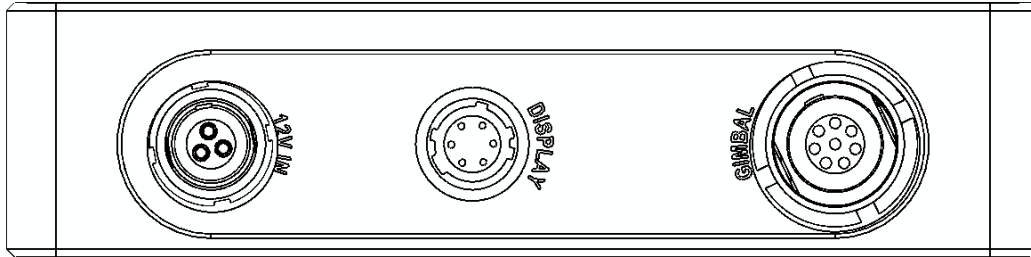

### 12V IN

LEMO ECG.0B.303.CLL

- 1- PWR GND
- 2- 11-17Vdc
- 3- n/c

### DISPLAY

HIROSE HR10-7R-6S73

- 1- VCC 5V
- 2- LED DATA
- 3- LED CLK
- 4- GP6
- 5- SIG GND
- 6- SIG GND

### GIMBAL

LEMO ECG.1B.308.CLL

- 1- PWR GND
- 2- 11-17VDC
- 3- SIG GND
- 4- GP3
- 5- SIG GND
- 6- GP4
- 7- SIG GND
- 8- GP5

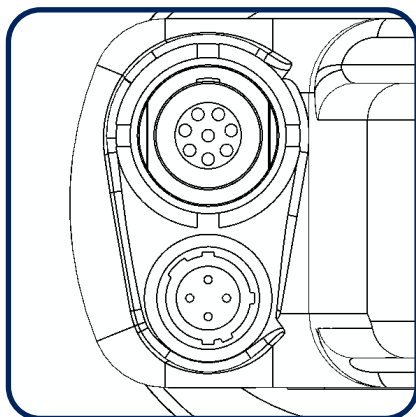

### GIMBAL

LEMO ECG.1B.308.CLL

- 1- PWR GND
- 2- 11-17VDC
- 3- SIG GND
- 4- GP3
- 5- SIG GND
- 6- GP4
- 7- SIG GND
- 8- GP5

### PAN ENCODER:

HIROSE HR10-7R-4S(73)

- 1 - PHASE A
- 2 - PHASE B
- 3 - VCC 5V
- 4 - GND

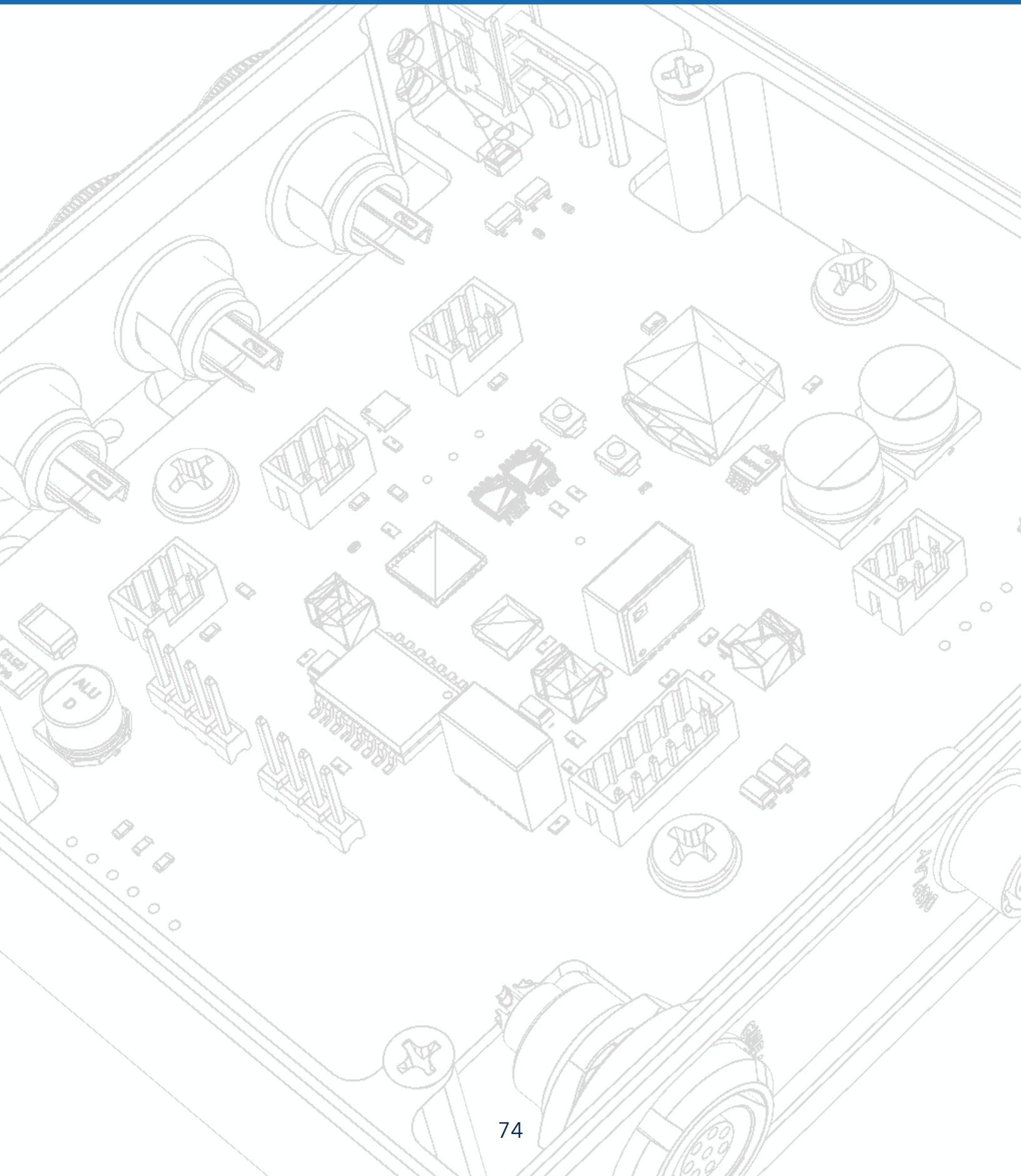

# Contact Tiffen

## **The Tiffen Company**

90 Oser Avenue  
Hauppauge, NY 11788  
**Phone:** (631) 273-2500 or 1(800) 645-2522  
**Fax:** (631) 273-2557

## **Tiffen-Steadicam**

2815 Winona Avenue  
Burbank, CA 91504  
**Phone:** (818) 843-4600 or 1(800) 593-3331  
**Fax:** (818) 843-8321

## **Tiffen International Ltd.**

Pinewood Studios  
Pinewood Road  
Iver Heath SL0 0NH  
United Kingdom  
**Phone:** +44 (0) 1753 783 960

## **Email:**

[techsupport@Tiffen.com](mailto:techsupport@Tiffen.com)

## **Web:**

[Tiffen.com/steadicam](http://Tiffen.com/steadicam)

## **Warranty:**

[Tiffen.com/warranty](http://Tiffen.com/warranty)

Designed and manufactured in the United States of America.  
Patents pending. Tiffen reserves the right to change specifications, accessories, etc. without prior notice.  
There is no implied or expressed warranty regarding this material. Thanks for reading the fine print!

STEADICAM®, M-1™, M-2™ and Steadicam® Volt™ are trademarks of the Tiffen Company, LLC.  
All other trademarks and product names appearing herein are the property of their respective owners.  
LIT-817001, Rev B © 2021 Tiffen Company, LLC. Created by Evan Barthelman