

360 EVO Stabilized Remote Head

OPERATING MANUAL

January 2024 • English

• Preliminary



Disclaimer

Before using the product, be sure to read and understand all respective instructions.

The product is available for commercial customers only.

For product specification changes since this document was published, refer to the latest publications of ARRI data sheets or data books, etc., for the most up-to-date specifications.

Not all products and / or types are available in every country. Please check with an ARRI sales representative for availability and additional information.

The information given in this document is subject to change without notice.

While ARRI endeavors to enhance the quality, reliability and safety of their products, customers agree and acknowledge that the possibility of defects thereof cannot be eliminated entirely. To minimize risk of damage to property or injury (including death) to persons arising from defects in the products, customers must incorporate adequate safety measures in their work with the system and have to heed the stated canonic use.

ARRI or its subsidiaries expressly exclude any liability, warranty, demand or other obligation for any claim, representation, or cause, or action, or whatsoever, express or implied, whether in contract or tort, including negligence, or incorporated in terms and conditions, whether by statute, law or otherwise. In no event shall ARRI or its subsidiaries be liable for or have a remedy for recovery of any special, direct, indirect, incidental, or consequential damages, including, but not limited to lost profits, lost savings, lost revenues or economic loss of any kind or for any claim by third party, downtime, good will, damage to or replacement of equipment or property, any cost or recovering of any material or goods associated with the assembly or use of our products, or any other damages or injury of the persons and so on or under any other legal theory.

Neither ARRI nor its subsidiaries assume any liability for infringement of patents, copyrights or other intellectual property rights of third parties by or arising from the use of ARRI products or any other liability arising from the use of such products. No license, express, implied or otherwise, is granted under any patents, copyrights or other intellectual property right of ARRI or others.

In the case one or all of the foregoing clauses are not allowed by applicable law, the fullest extent permissible clauses by applicable law are validated.

Imprint

© 2023 Arnold & Richter Cine Technik GmbH & Co. Betriebs KG. All rights reserved.

The device contains proprietary information of Arnold & Richter Cine Technik GmbH & Co. Betriebs KG; it is provided under a license agreement containing restrictions on use and disclosure and protected by copyright law. Reverse engineering of the software is prohibited.

No part of this publication may be used for distribution, reproduction, transmission, transcription, storage in a data retrieval system, or translated into any language in any form by any means without the prior written permission of Arnold & Richter Cine Technik GmbH & Co. Betriebs KG.

If you are downloading files from our web pages for your personal use, make sure to check for updated versions.

ARRI cannot take any liability whatsoever for downloaded files, as technical data are subject to change without notice.

Due to continued product development the information in this document may change without notice. The information and intellectual property contained herein is confidential between ARRI and the client and remains the exclusive property of ARRI. If you find any problems in the documentation, please report them to us in writing. ARRI does not warrant that this document is flawless.

ARRI, ARTEMIS 1, ARTEMIS 2, TRINITY 1, TRINITY 2, SRH3, SRH360 and SRH360-EVO are trademarks or registered trademarks of Arnold & Richter Cine Technik GmbH & Co. Betriebs KG. All other brands or products mentioned are trademarks or registered trademarks of their respective holders and should be treated as such.

Original version.

For Further Assistance

Arnold & Richter Cine Technik GmbH & Co. Betriebs KG

Herbert-Bayer-Str. 10

D-80807 Munich

Germany

E-mail: service@arri.com

Website: www.arri.com/en/technical-service

Content

1	About this Document	7
2	Safety Instructions	8
3	About the 360 EVO Remote Head	14
3.1	Intended Use	14
3.2	Application Requirements	14
3.3	Identification	15
3.4	Environmental Conditions	15
3.5	Technical Data	16
3.6	Dimensional Drawing	16
3.7	Scope of Delivery and Warranty	17
4	360 EVO Remote Head Overview	18
4.1	Overview Back / Right	18
4.2	Overview Front / Left	19
4.3	Overview Left Junction Box	20
4.4	Overview Right Junction Box	20
4.5	Overview AUX Junction Box	20
4.6	Overview Junction Box PAN Axis	21
4.7	Overview Ring Lower Back	21
4.8	Overview Ring Lower Front	21
4.9	Interfaces	22
4.10	Pin Out	22
5	Mounting and Assembly	24
5.1	Power Supply	24
5.2	Batteries (recommended)	24
5.3	Wiring Power Supply	24
5.4	360 EVO Power Supply Cables	25
5.5	360 EVO Power Communication Cables	25
6	Remote Head Attachment	26
6.1	Mounting the Stabilized Remote Head	26
6.2	ISO Damper	26
7	Camera Preparation	27
7.1	Recommended Camera Dovetail Plates and Accessories	27
8	Camera Mounting	28
8.1	TILT Lock	28
8.2	Overcurrent Detection Remote Head	28
9	Camera Connection	29
9.1	Camera Power Cables	29
9.2	Camera Video Cables	29
9.3	LBUS Cables	30
9.4	Aux Power Cables	30
10	360 EVO Remote Control Panel	31

- 11 Interfaces Remote Control Panel EVP 34**
 - 11.1 Pin Out Remote Control Panel EVP..... 34
- 12 Remote Control Panel / Power Up 35**
 - 12.1 Remote Control Panel Hard Wiring..... 35
 - 12.2 Wireless Application..... 35
- 13 Emergency Stop 36**
- 14 Cleaning, Repair and Disposal..... 37**
- 15 Transportation and Storage 39**
- 16 ARRI Service Contacts 40**

1 About this Document

This operating manual is aimed at everyone involved in using the device. It provides directions on how to operate it safely and as intended. To ensure safe and correct use, all users must read the operating manual before using the device for the first time.

This operating manual is an essential part of the device. It must be easily accessible and in close proximity to the device so that users can use it as a reference anytime.

The separate user manual contains more detailed information about the features and functionalities of the device. Please visit the website www.arri.com to download the user manual.

Keep the operating manual, the user manual and all other operating and assembly instructions belonging to the device in a safe place for future reference and possible subsequent owners.

For more details about the product, please refer to the ARRI website at:

[360 EVO product page](#)



Searchkeys: 360 EVO, D45 1000 XXXX

[ARRI documentation portal](#)



Document Revision History

Document ID: D45 1000 XXXX

Version	Release	Date	Note
1.0		December 2023	First Release

2 Safety Instructions

This safety information is in addition to the specific operating instructions in general and must be strictly observed for safety reasons. Read and understand all safety and operating instructions before you operate or install the device. Retain all safety and operating instructions for future reference. Always follow the instructions in this and all documents supplied with the device to avoid injury to yourself or others and damage to the device or other objects.

Assembly and operation should only be carried out by trained staff familiar with the device. Only use the tools, materials and procedures recommended in this document. For the correct use of other equipment, see the manufacturer's instructions.

These instructions use safety instructions, warning symbols and signal words to draw your attention to different levels of risk:



DANGER

DANGER indicates an imminent danger. If not avoided, death or serious injury will result.

Always follow the recommended measures to avoid this hazardous situation.



WARNING

WARNING indicates a possibly imminent danger. If not avoided death or serious injury may result.

Always follow the recommended measures to avoid this potentially hazardous situation.



CAUTION

CAUTION indicates a potentially imminent danger. If not avoided, slight or minor injuries may result.

Always follow the recommended measures to avoid this potentially hazardous situation.



NOTICE

NOTICE indicates a potentially harmful situation. If not avoided, the equipment or something in its surrounding may be damaged.

Always follow the recommended measures to avoid this situation.

HINT

Not relevant to safety, **HINT** provides additional information to clarify or simplify a procedure.

Warning Symbols and Product Labels



General warning sign



Warning of electrical voltage



Warning of hot surfaces



Warning of sharp element



Warning of the risk of crushing



Warning of obstacles on the ground



Please read all instructions carefully before using the product for the first time.



Direct Current symbol found on electronics requiring or producing DC power.

General Safety Instructions



DANGER

Risk of Serious Injury through Crushing Body Parts

- ▶ During setup and throughout operation, make sure that no fingers or limbs get caught between the outer yoke and inner ring.
- ▶ Depending on the weight and length of the camera, a high kinetic force can occur between the outer and inner ring. Serious injuries can occur if you are not careful. If this should still happen, immediately disconnect the power supply and seek medical attention if necessary.
- ▶ Clearly mark the movement area of the device with a barrier or a clearly visible marking (e.g. signal tape) on the floor.

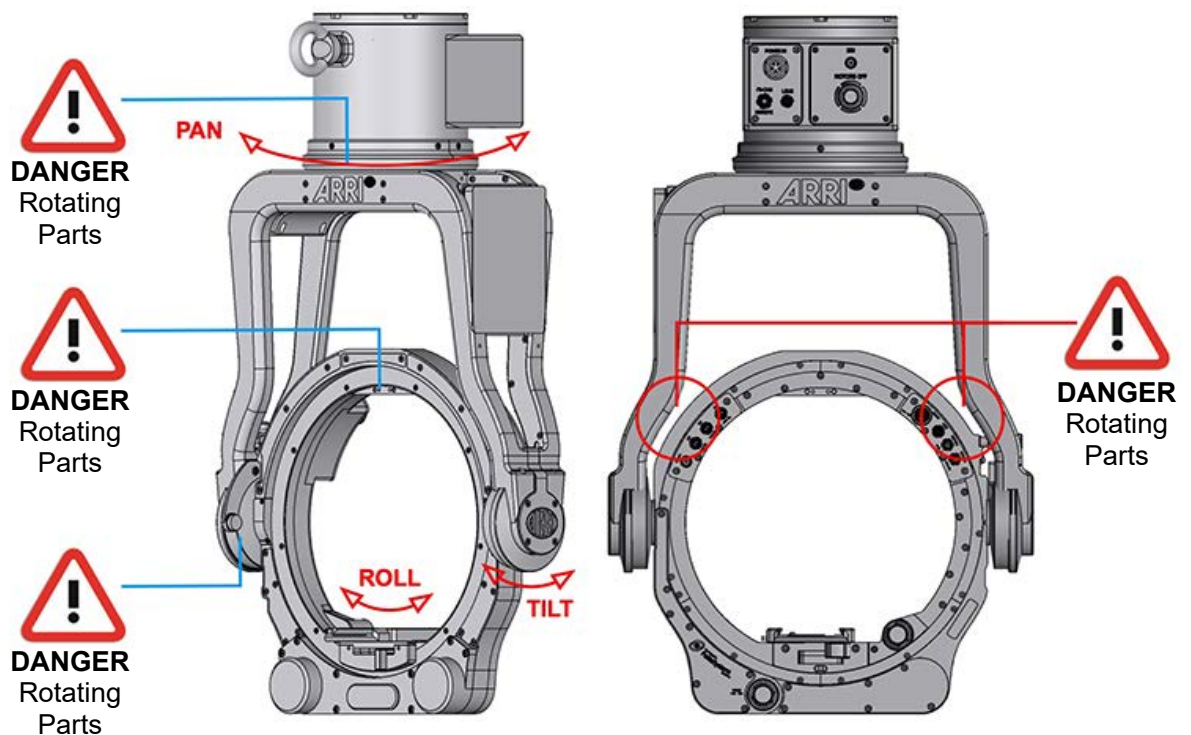



WARNING

Risk of Injury through High Torque and Unbalanced Load

Keep in mind that the 360 EVO stabilized remote head is a fully stabilized Gimbal based device with a payload capacity of up to 30 kg / 66 lbs. The amount of available torque is very high.

- ▶ Always keep a safe distance between persons, objects and the assembled system. Protruding components (especially lenses) can cause injury or property damage due to shock or impact.
- ▶ Always balance the system components properly. During rotational movements, the system can become uncontrollable due to too much imbalance.

Safe area

Unsafe area





WARNING

Operation of the 360 EVO in Case of Obvious Damage

Risk of electric shock and fire hazard caused by short circuit.

- ▶ Never use the device if electrical lines or housing are visibly damaged.
- ▶ Only use the type of power source indicated in the manual.
- ▶ Always grip the power plug to unplug the power cable.
- ▶ Do not lay cables over sharp edges (e.g. sheet metal, profile or other cut edges). Damaged cables can cause electric shock, short circuit or fire.
- ▶ Do not remove or deactivate any safety measures from the device (incl. warning stickers or paint marked screws).
- ▶ Do not try to repair the device. Repairs may only be carried out by an authorized ARRI service center.



WARNING

Falling System Parts

Do not built up or assemble the 360 EVO the wrong way. It can fall down and cause serious injuries and damage to the device or property.

- ▶ Installation and operation must only be carried out by approved persons who know the device. Obey the accident prevention regulations.
- ▶ Never put the device on a not stable trolley or hand truck, stand, tripod, bracket, table or any other not stable support device.
- ▶ Always place the device on dedicated support devices.
- ▶ Always use a suitable safety rope when you use the device above floor level (i.e. on cranes).
- ▶ Secure the device and its accessories against falling and tipping over. Obey the general and local safety regulations.



WARNING

Positioning the 360 EVO on an Inclined or not safe Surface

Risk of injury caused by the 360 EVO tipping over.

- ▶ Obey the accident prevention regulations.
- ▶ Put the device on level and stable ground that can support the weight of the device and all accessories.
- ▶ Do not put the device on an unstable trolley or hand truck, stand, tripod, bracket, table or any other unstable support device.
- ▶ Always put the device on dedicated support devices.
- ▶ Use only accessories approved by ARRI. The use of accessories not approved by ARRI is at your own risk. Please obey all related safety guidelines.

**WARNING****Overloading the 360 EVO by Persons or Objects**

Risk of injury caused by the 360 EVO tipping over.

- ▶ Do not lean on the device.
- ▶ Do not put any not approved objects on the device.
- ▶ Do not hang any not approved objects on the device.
- ▶ Use only accessories approved by ARRI. The use of accessories not approved by ARRI is at your own risk. Please obey all related safety guidelines.

**WARNING****Connected Cable on the Floor**

Risk of injury caused by tripping, falling or slipping over connected cables.

- ▶ Always properly secure cables connected to the device and accessories.
- ▶ Always install cables that they cannot be tripped over.
- ▶ If necessary, use a cable duct or secure the cables with adhesive tape.
- ▶ Always disconnect the cables from the device and accessories before moving.

**CAUTION****Use of the 360 EVO or 360 EVO Accessories in a Humid Environment and with Condensation**

When you move the device and the accessories from a cool to a warm location or when the device is used in a damp environment, condensation may form inside the device, and on internal or external electrical connections. Do not operate the device while condensation is present. It bears risk of electric shock and/or fire caused by a short circuit.

- ▶ Do not operate the device and accessories when condensation occurs.
- ▶ When you move the device and accessories from a cool to a warm environment, wait for some time for the components to warm up.
- ▶ Find a warmer storage location to decrease the risk of condensation.

**CAUTION****Hot Surfaces on 360 EVO and 360 EVO Accessories**

During extended operation, high data rates and/or operation at high ambient temperatures, the device's surface and the area around the fan outlet can get hot. Direct sunlight can result in device housing temperatures above 60° C (140° F).

- ▶ Do not put covers on, clog or block the fan in- or outlets while the device is powered.
- ▶ Do not put the device system near any heat sources during operation.
- ▶ At ambient temperatures above 25° C (77° F), prevent the device and accessories from being exposed to direct sunlight.



CAUTION

Unhealthy Posture or too much Physical Exertion During Operation

Improper handling of the 360 EVO bears risk of permanent long term physical damage to the human locomotive system.

- ▶ Keep an ergonomic posture when operating and carrying the 360 EVO.



CAUTION

Radio Radiation caused by External Radio Accessories

May cause physical impairments such as sleep disturbances and stress.

- ▶ Always follow the manufacturers instructions.
- ▶ Use only 360 EVO components approved by ARRI. The use of components not approved by ARRI is at your own risk.
- ▶ Obey all relevant safety guidelines.

3 About the 360 EVO Remote Head

The major improvement with the SRH-360 is to the pan axis functionality: A new slip ring permits unlimited rotation of the head. At the same time, the torque of the pan motor has been increased by 50%, allowing it to compensate for powerful centrifugal forces when shooting high-speed camera moves. This makes the SRH-360 even more flexible for dynamic environments such as action, stunts, vehicle work, sports, and live music performances.

3.1 Intended Use



NOTICE

All versions of the 360 EVO and its accessories are intended exclusively for professional use. It must be used only by skilled and trained personnel. The product and its accessories must not be used by inexperienced users and without proper training.

Read and understand the operating manual and the user manual before use.

Use the product and its accessories only for the purpose described in this document. Always follow the safety instructions and system requirements for all equipment involved. ARRI assumes no liability for damages or changes that are caused by improper use. You are not allowed to modify the product and its accessories.

3.2 Application Requirements

Stabilizing remote heads is an extremely complex and sometimes demanding task, and therefore stabilized remote heads have their limitations. For example, the remote head can only correct angular movements, not parallel movements.

This means that if the remote head is directly attached to a hoist, mast, or structure that is subject to vertical motion, it cannot compensate for lift as it moves up and down (since this motion is parallel). To absorb vertical and parallel movements, the remote head must be mounted on a suitable shock absorber.

Stabilization systems are limited by motor power and by their bandwidth or frequency response.

Too fast movements required to correct the camera position may not be compatible with the system's capabilities. This is evident when using longer lenses. The use of suitable iso-dampers improves the application.

By mounting a suitable iso-damper between the remote head and the head's attachment point, the fast, unwanted movements are absorbed so that stabilization occurs with unwanted movements that are slower and within the system's range. There are many iso-dampers that vary in design and quality. Choosing the right iso-damper is as important as the stabilized head itself.

Another purpose of iso-dampers is to decouple the stabilized remote head from the resonance and bending of the mounting point.

All gimbal-stabilized remote heads always face some drift. The drift is an unwanted movement of the system, usually caused by the gyroscopes and the earth rotation, which cannot be measured by the MEMS sensors. Drift is usually measured in degrees per hour. The 360 EVO stabilized remote head has a very small drift that is only noticeable when the head is stationary for an extended period of time. The average drift can be as low as 10° in 30 minutes. The drift can also be caused by an uncalibrated joystick or a loose camera setting or a too soft iso-damper.

It is crucial that the camera and lens, as well as the remote head, bend or flex as little as possible. The entire setup must be as stiff as possible, as any flexing can cause vibration or oscillation of the head. Every attempt should be made to improve the rigidity of the camera and head mount and to reduce or eliminate any flexing.

Many different camera and lens packages can be used with the 360 EVO and there are also many different ways to mount the remote head. Therefore, it is not always possible or practical to achieve perfect conditions in terms of rigidity and balance. This can result in the load becoming unstable and

wobbling and swinging when stabilization is active. In such situations, it is necessary to adjust the PID parameters. The correct adjustment of these PID values is crucial for the proper functioning of the system.

An unbalanced camera setting puts more strain on the motors of the 360 EVO. The system requires more force to move the load, and this sometimes increases the possibility that the load will become unstable and that the remote head will overcompensate or wobble and oscillate.

Please remember that the way the stabilized remote head is mounted has a direct impact on its performance. The total mass of the head and its load are important considerations when choosing how and where to mount it. This torque changes in direction and amplitude to varying degrees. The more stable the mounting, the easier it is for the system to work well. Sometimes even the leveling linkage of a camera crane has play, so the mounting point can move slightly with reversed loads. If there is mechanical play between the components of the shock absorber, the overall system may vibrate. Iso-dampers with the appropriate dimensions and hardness should always be used - the system may become too elastic if the iso-damper used is too soft, resulting in vibrations.



NOTICE

Each of these aspects can lead to the motor power of single axis having to be lowered, which will limit the effectiveness of the overall stabilization.

3.3 Identification

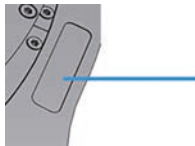

The 360 EVO serial number is located on the back of the lower ring of the 360 EVO.

The serial number consists of the last 4 digits of the product number K2.00YYYYYY-1234 (here: 1234).

3.4 Environmental Conditions

The 360 EVO should only be used and stored under certain environmental conditions.

Check the following conditions before commissioning and operation:

Permissible Operating Temperature	-20° C to +45° C / -4° F to +133° F
Permissible Storage Temperature	-30° C to +70° C / -22° F to +158° F
Permissible Humidity	95% RF, non condensing, from -20° C to +45° C / -4° F to +133° F

3.5 Technical Data

Height	652 mm / 25.67 in
Width	412 mm / 16.22 in
Depth Head	150 mm / 5.9 in
Depth Base	246 mm / 9.68 in
Weight	11.6 kg / 25.57 lbs
Stabilized Axles	3 (Pan, Tilt, Roll)
Maximum Payload	up to 30 kg / 66 lbs
Maximum Tilt Range	+60° / -110°
Maximum Roll Range	+/- 360°
Maximum Pan Range	Unlimited / Slip Ring
Maximum Tilt Rate	240° / sec
Maximum Pan Rate	240° / sec
Ring Diameter	260 mm / 10.24 in
Ring Height Center	209 mm / 8.23 in

Note: Technical data is subject to change without notice.

3.6 Dimensional Drawing

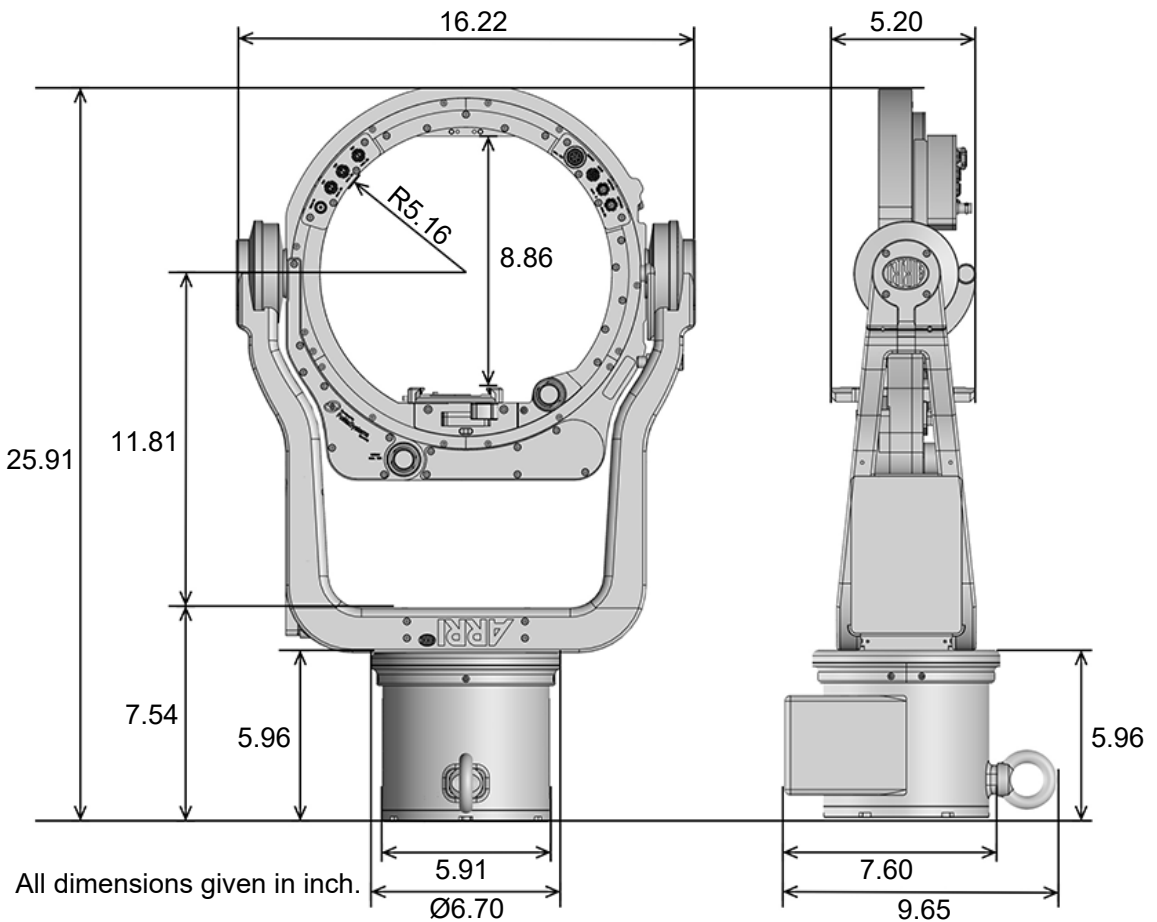

3.7 Scope of Delivery and Warranty



NOTICE

The packaging consists of recyclable materials. For the sake of the environment, dispose the packaging material at a suitable disposal site. Always store, ship and dispose according to local regulations. ARRI is not liable for consequences from inadequate storage, shipment or disposal.

On delivery, please check if package and content are intact. Never accept a damaged or incomplete delivery.

Delivery

A complete set KK.0050103, "360 EVO Basic Set, no joystick", delivery includes:

- 1x K2.0049722, 360 EVO Stabilized remote Head
- 1x K2.0049724, RCP-2 EVO Remote Control Panel
- 1x K2.0049726, Case 360 EVO Stabilized Remote Head

For scope of warranty, please ask your local ARRI Service Partner. ARRI is not liable for consequences from inadequate shipment, improper use or use of third-party products.

4 360 EVO Remote Head Overview

4.1 Overview Back / Right

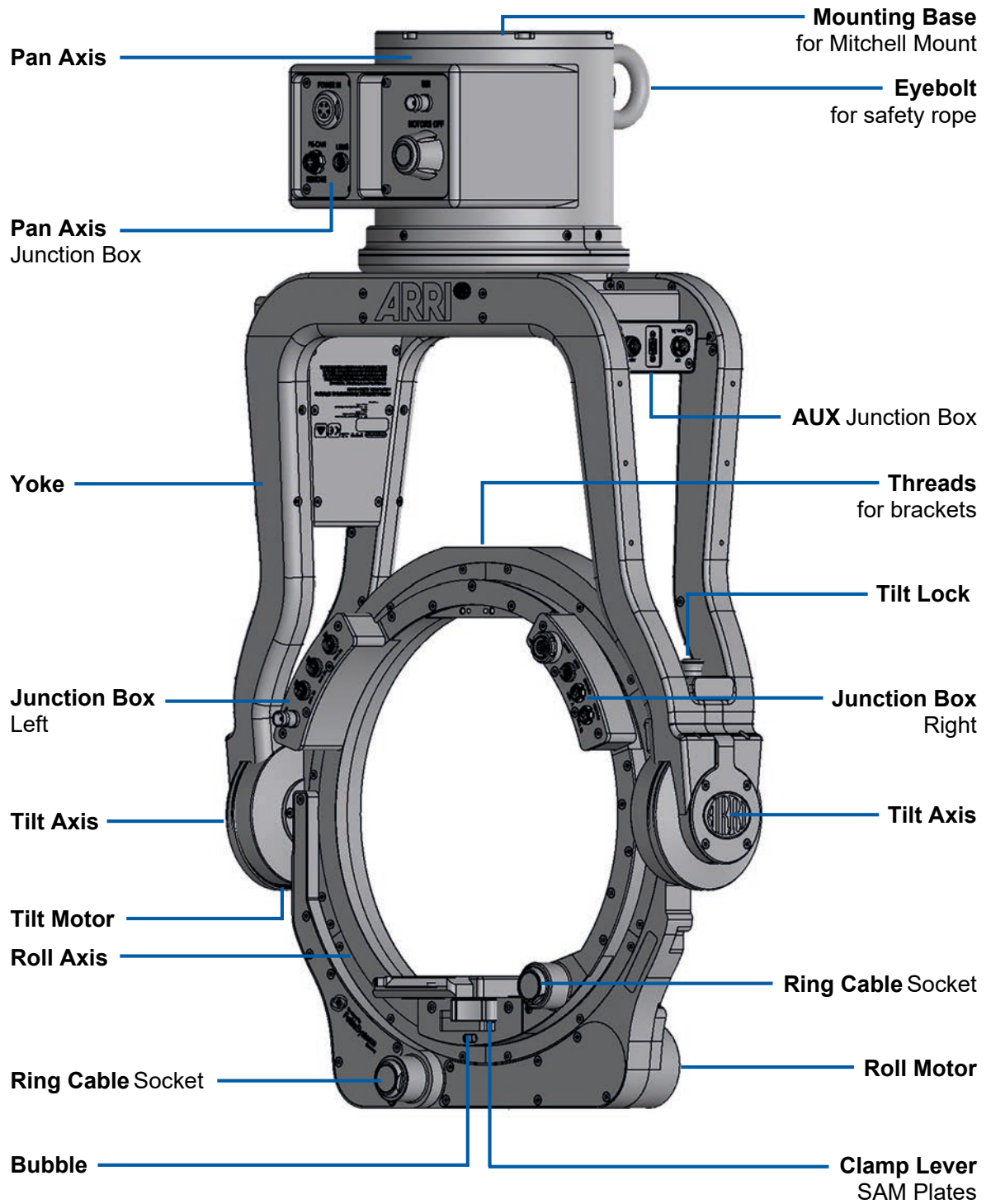

4.2 Overview Front / Left

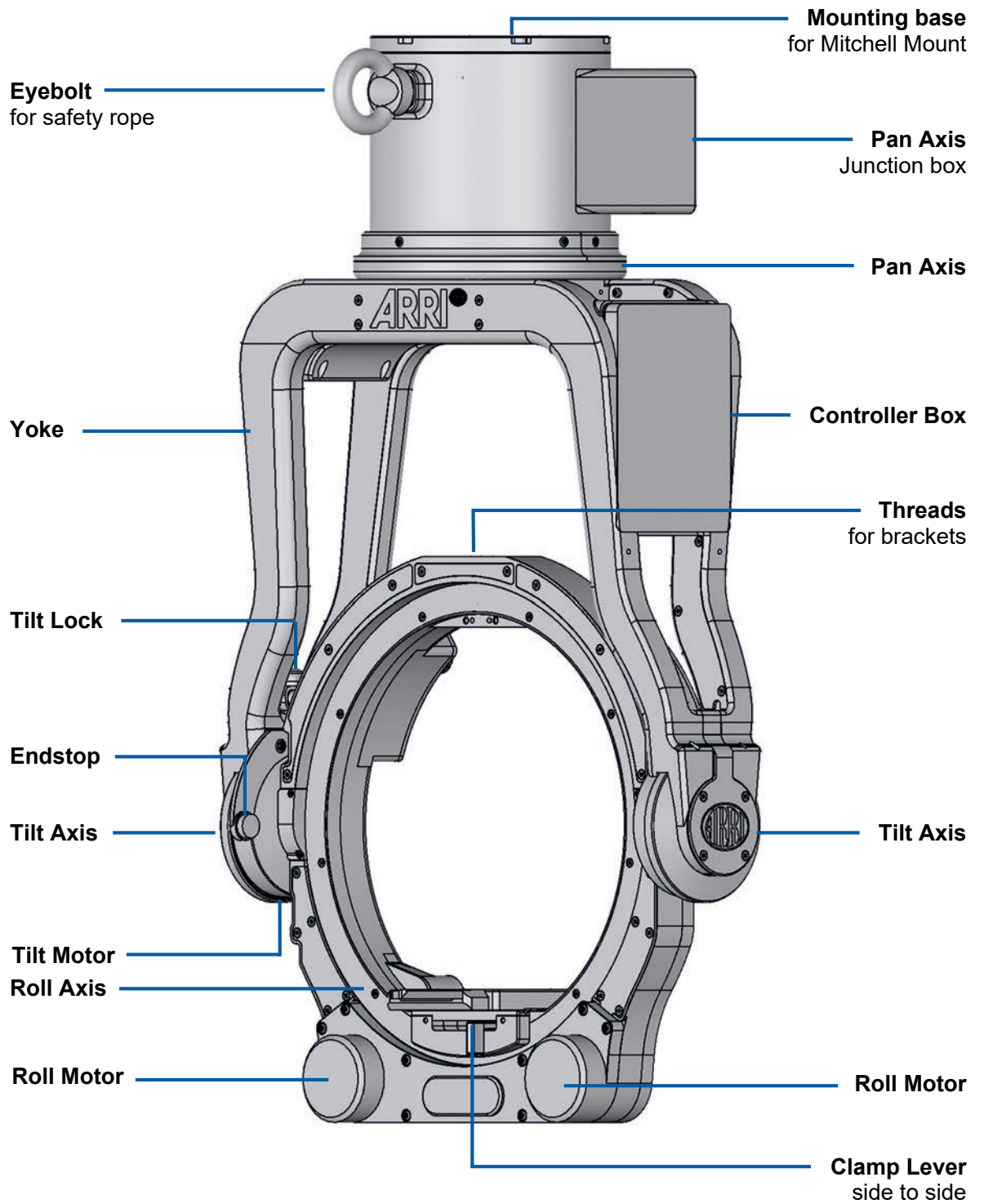

4.3 Overview Left Junction Box

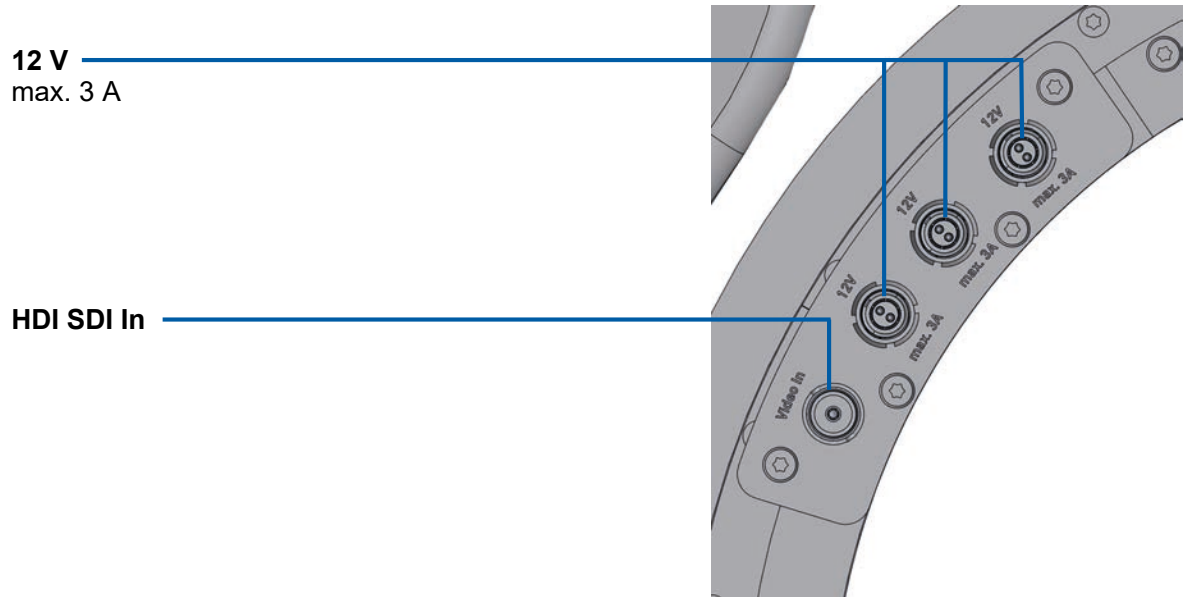

4.4 Overview Right Junction Box

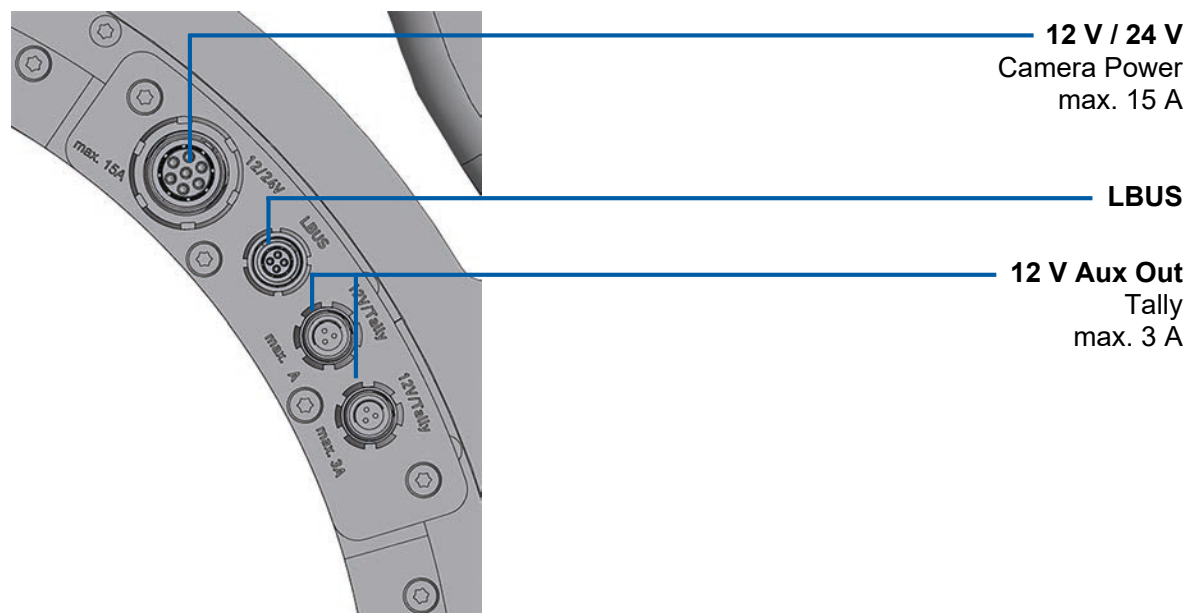

4.5 Overview AUX Junction Box

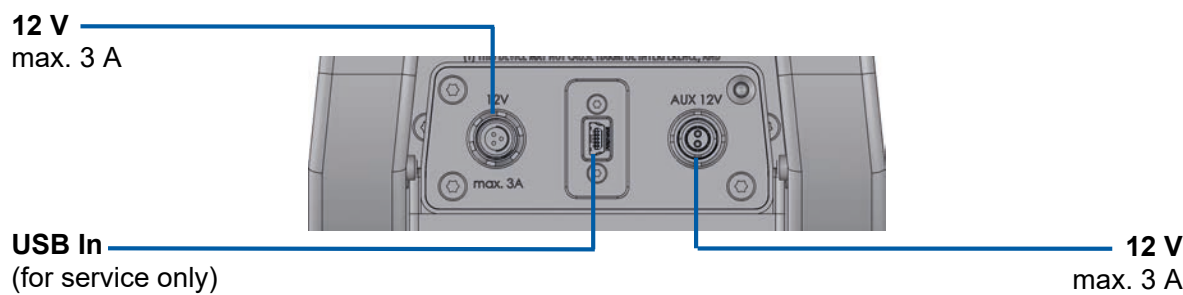

4.6 Overview Junction Box PAN Axis

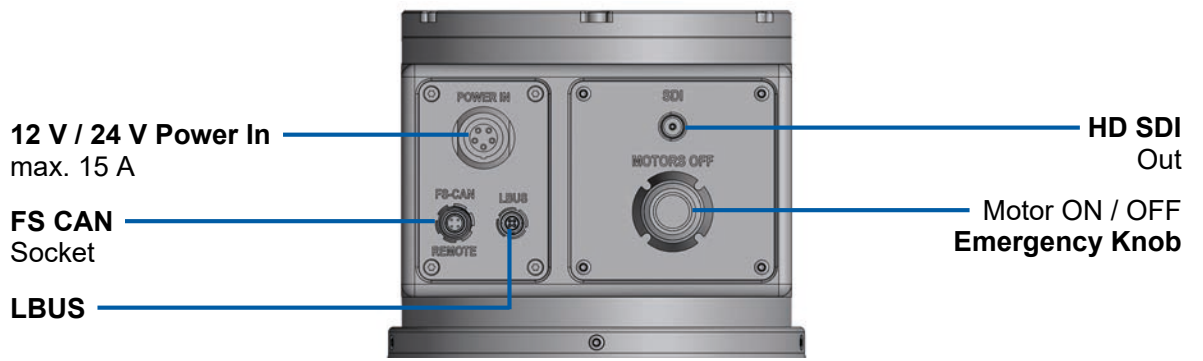

4.7 Overview Ring Lower Back

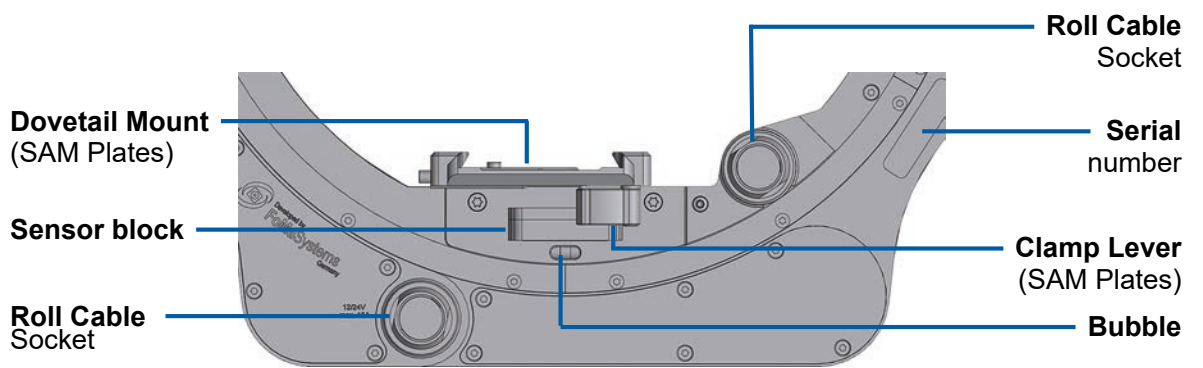

4.8 Overview Ring Lower Front

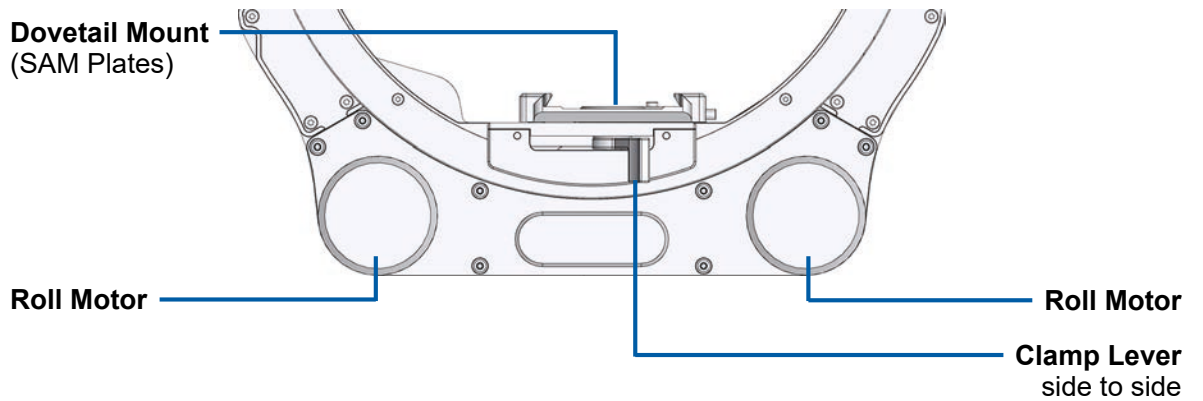

4.9 Interfaces

12 V / 24 V Camera Power	Lemo 2B 7pin	12 V / 24 V max. 15 A
LBUS	Lemo 0B 4pin	Data / 12 V max. 3 A
Aux / Tally	Fischer 3pin	12 V max. 3 A
Aux	Lemo 0B 2pin	12 V max. 3 A
HD SDI	BNC	6G
12 V / 24 V Power In	Lemo 3B 5pin	12 V / 24 V max. 15 A
FS CAN	Fischer 4pin	Data / 12 V max. 3 A

4.10 Pin Out



12 V / 24 V Camera Power

Lemo 2B 7pin (12 V / 24 V max. 15 A)

Pin 1	Ground
Pin 2	Ground
Pin 3	+ 12 V
Pin 4	+ 12 V
Pin 5	+ 24 V
Pin 6	+ 24 V
Pin 7	Bat. Data

**Shown from mating side*



12 V Aux Power

Lemo 0B 2pin (12 V max. 3 A)

Pin 1	Ground
Pin 2	12 V

**Shown from mating side*

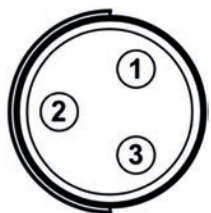

Aux / Tally

Fischer 3pin (12 V max. 3 A)

Pin 1	Ground
Pin 2	+ 12 V
Pin 3	Tally

**Shown from mating side*

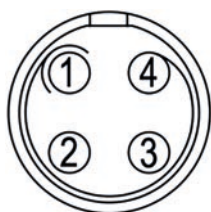

LBUS

Lemo 0B 4pin (24 V max. 3 A)

Pin 1	Ground
Pin 2	CAN Low
Pin 3	+ 12 V / + 24 V
Pin 4	CAN High

**Shown from mating side*

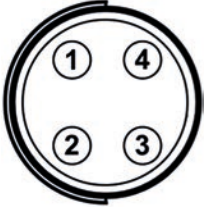
**CAN Bus FS**

Fischer 4pin (12 V max. 3 A)

Pin 1	Ground
Pin 2	CAN 1 Low
Pin 3	CAN 2 High
Pin 4	+ 12 V

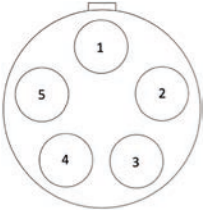
Shown from mating side*12 V / 24 V Power In**

Lemo 3B 7pin (12 V / 24 V max. 15 A)

Pin 1	Ground
Pin 2	FS low
Pin 3	FS high
Pin 4	+ 12 V In
Pin 5	+ 24 V In

**Shown from mating side*

5 Mounting and Assembly

5.1 Power Supply



CAUTION

Loss of Performance through Wrong Cables

Use only suitable and recommended power cords, batteries and power supplies.

- ▶ To perform in the desired way, the stabilized remote head requires at least min. **24 V / 8 A** over the **3pin XLR** plug and min. **12 V / 5 A** via the **4pin XLR** plug.
- ▶ The power supply for the EUT, has to provide "SELV" and a short-circuit-proof „limited power source“, according to EN 60950-1.

5.2 Batteries (recommended)



BEBOB CUBE 1200	www.bebob.de
Anton Bauer CINE VCLX	www.antonbauer.com
Block Battery	www.blockbattery.com
Cinepower Magnum 60	www.cinepower.com

5.3 Wiring Power Supply



5.4 360 EVO Power Supply Cables

Use only appropriate cables, like:

K0.0019478	SRH Power Supply Set, 600 W
K2.0019303	SRH Power Supply Power and Data Cable, 12 V / 24 V, 20 m / 65.6 ft
K0.0012269	SRH High Capacity Camera Power Cable Set
K0.0021437	SRH High Capacity Battery Power Cable Set, 12 V / 24 V, 20 m / 66 ft
K0.0021438	SRH High Capacity Battery Power Cable Set 12 V / 24 V, 10 m / 33 ft
K2.0019306	SRH High Capacity Battery Power Cable, 12 V / 24 V, 0.5 m / 1.64 ft
K2.0021430	SRH High Capacity Battery Power Cable 12 V, 4pin XLR, 20 m / 66 ft
K2.0021429	SRH High Capacity Battery Power Cable 24 V, 3pin XLR, 20 m / 66 ft
K2.0021428	SRH High Capacity Battery Power Cable 12 V, 4pin XLR, 10 m / 33 ft
K2.0021427	SRH High Capacity Battery Power Cable 24 V, 3pin XLR, 10 m / 33 ft

5.5 360 EVO Power Communication Cables

Use only appropriate cables, like:

K2.0033762	SRH FS CAN Bus Cable, 1 m / 3.2 ft
K2.0037701	SRH FS CAN Bus Cable, 5 m / 16.4 ft
K2.0019302	SRH FS CAN Bus Cable, 10 m / 32.8 ft
K2.0019301	SRH FS CAN Bus Cable, 25 m / 82 ft
K2.0019300	SRH FS CAN Bus Coupler, 0.2 m / 0.65 ft

6 Remote Head Attachment

6.1 Mounting the Stabilized Remote Head



DANGER

Danger to Life due to Falling Parts, High Speed Collision and Impact

Consider all safety regulations!

Only experienced, authorized operators or grip personal must mount the stabilized remote head to a crane, dolly, support arm or any other device.



NOTICE

In order to be able to use the maximum stabilisation performance of the 360 EVO, the remote head may only be mounted on cranes, dollies, towers, cable cams or other support suitable for use.

6.2 ISO Damper



NOTICE

Stabilization systems are limited by engine power, as well as their bandwidth or frequency response. Stabilized remote heads have difficulty isolating certain shocks and violent movements in the vertical axis. Even certain lateral movements cannot always be perfectly corrected.

Very fast movements required to correct the camera position may not be within system capabilities. This can be seen when using longer lenses.

The use of Iso Dampers devices improves the application.

Mounting the Iso Dampers device between the remote head and the mounting point of the head, will soak up the fast, unwanted movements, leaving the stabilization with unwanted movements that are slower and within the bandwidth of the system. When a stabilized remote head, such as the SRH-3 & SRH-360, is attached to a fast-moving vehicle that travels over difficult terrain, extreme shocks and forces are applied to the remote head.

Vibration Isolator for SRH-3, SRH-360, 360 EVO

The vibration isolator for SRH, Gen. 2 offers Mitchell Mounts at both ends.

To allow quick and easy mounting of the stabilized remote head, the shape of the lower blue Mitchell mount is optimised for the SRH-3 & SRH-360, and 360 EVO.

Order codes

KK.0039359 Vibration Isolator for SRH, Gen. 2, metric, Basic Set

KK.0041936 Vibration Isolator for SRH, Gen.2, Imperial, Basic Set



7 Camera Preparation



WARNING

Risk of Injury and Damage due to Unexpected Movement

During the setup of the camera, the **TILT lock must be locked / activated!**

Before switching **ON** the remote head, the **TILT lock must be deactivated!**

An activated TILT lock can cause damage due to overheating of the tilt motors.



NOTICE

The entire balancing procedure of the 360 EVO stabilized remote head is based on a symmetrical camera setup and neutral weight distribution.

Only with a well executed camera preparation, a precise placement of the Center Of Gravity of the camera setup, the stabilized 360 EVO remote head can provide the best performance.

7.1 Recommended Camera Dovetail Plates and Accessories

We strongly recommend the use of the so-called Stabilizer Adapter Mount / SAM plates.

The special SAM plates ensure a secure and vibration-free attachment of the camera to the EVO 360.



Please follow this link to see the available products: [Dovetail plates and brackets](#)

In order to fix the camera setup even better, also from above, to achieve higher speeds during driving shots and above all to avoid unwanted and unnecessary vibration, we strongly recommend to mount the Top Attachment Bracket TAB-1 on top of the camera setup.



Order code

K2.0041117 TAB-1 Top Attachment Bracket

8 Camera Mounting

8.1 TILT Lock

TILT Lock IN

During the setup of the camera, the **TILT lock** must be **locked / activated!**

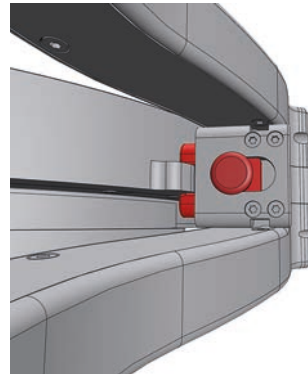

TILT Lock OUT

Before switching **ON** the remote head, the **TILT lock** must be **deactivated!**

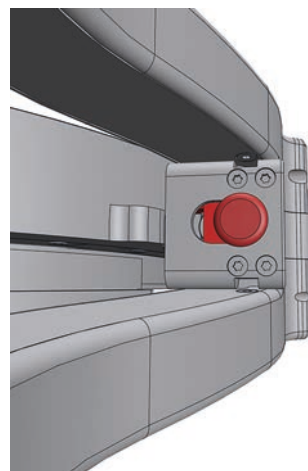

8.2 Overcurrent Detection Remote Head



NOTICE

Motor Protection Circuit

If the remote head control detects that one or more of its axes cannot be moved for more than 20 sec on the pan and tilt axis or 5 sec on the roll axis seconds, all motors are automatically switched off and a corresponding message is displayed on the remote control.

9 Camera Connection

9.1 Camera Power Cables

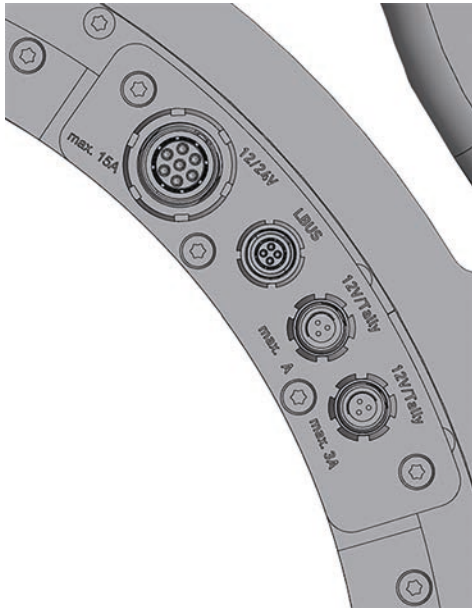

Use only appropriate cables, like:

- K2.0039443** Cam Pwr Gen. 2, ALEXA 35, Mini, Amira, 24 V, 8pin
- K2.0039446** Cam Pwr Gen. 2, ALEXA LF, 24 V, 2pin Fischer
- K2.0039447** Cam Pwr Gen.2, Alexa Mini, Amira, 12 V, 8pin
- K2.0040329** Cam Pwr Gen.2, 4 pin XLR, 12 V, 90° elbow
- K2.0039448** Cam Pwr Gen.2, 4 pin XLR, 12 V
- K2.0039449** Cam Pwr Gen.2, RED Monstro, 12 V
- K2.0039450** Cam Pwr Gen.2, RED Ranger, 24 V
- K2.0039451** Cam Pwr Gen.2, Sony Venice, 4pin XLR, 24 V

9.2 Camera Video Cables

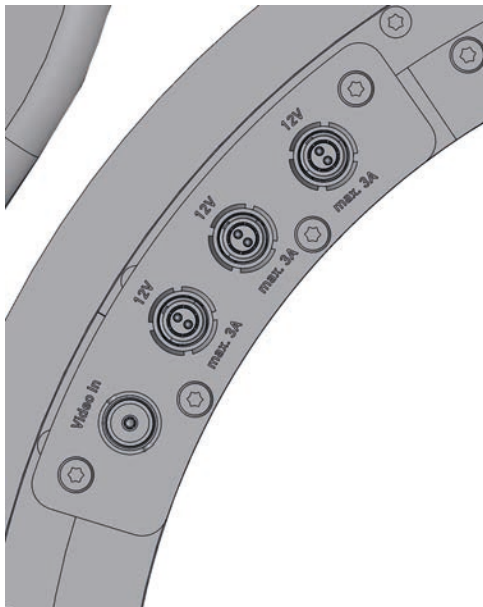

Use only appropriate cables, like:

- K2.0010476** HD SDI BNC Cable
- K2.0041984** 12G HD SDI BNC Cable, 0,63 m / 25 in
- K2.0044234** 12G HD SDI BNC Cable, 0,84m / 33 in

9.3 LBUS Cables



Use only appropriate cables, like:

- K2.0006749** Cable LBUS-LBUS (0.2 m / 8 in)
- K2.0006750** Cable LBUS-LBUS (0.3 m / 1 ft)
- K2.0006751** Cable LBUS-LBUS (0.5 m / 1.5 ft)
- K2.0006752** Cable LBUS-LBUS (0.8 m / 2.6 ft)

9.4 Aux Power Cables



CAUTION

Risk of Damage by Overloading the Power Source

The 12 V auxiliary power consumption must not exceed 14.4 V / 3 Amps.

Therefore, we do not recommend the use of D-Tab distributors, because they allow the connection of too many consumers.

10 360 EVO Remote Control Panel

Dimensions

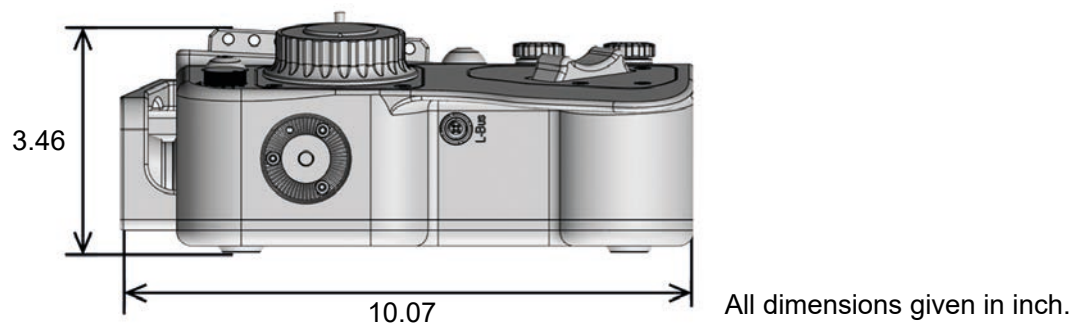
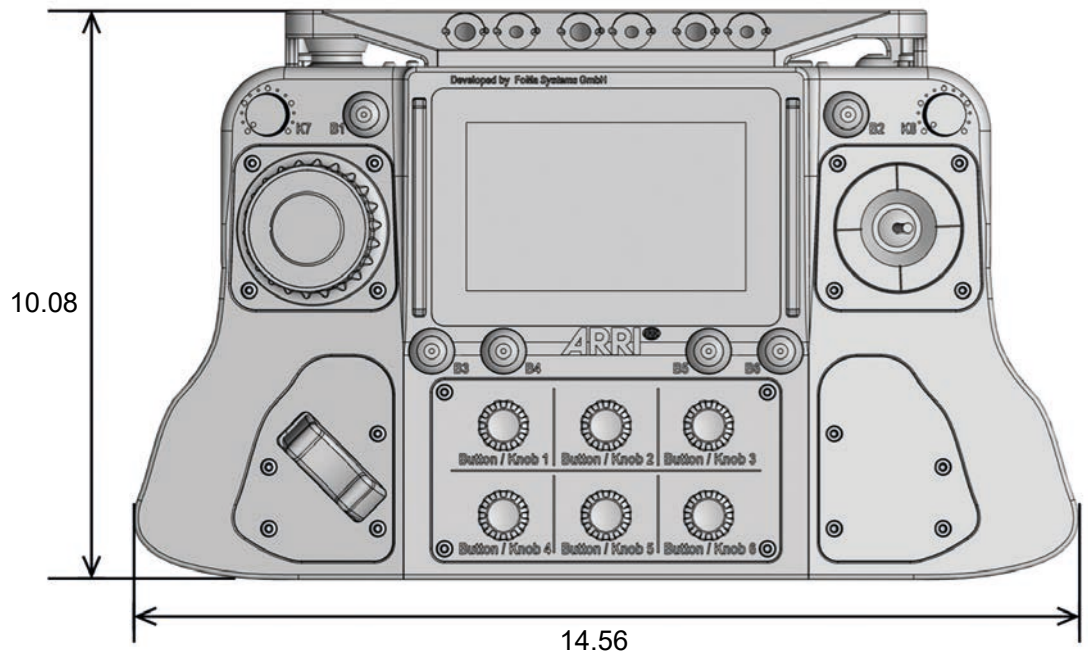

All dimensions given in inch.

Width	370 mm / 14.56 in
Depth	256 mm / 10.07 in
Height	88 mm / 3.46 in (without joystick)
Weight	3.1 kg / 6.83 lb (fully equipped)

Overview Top

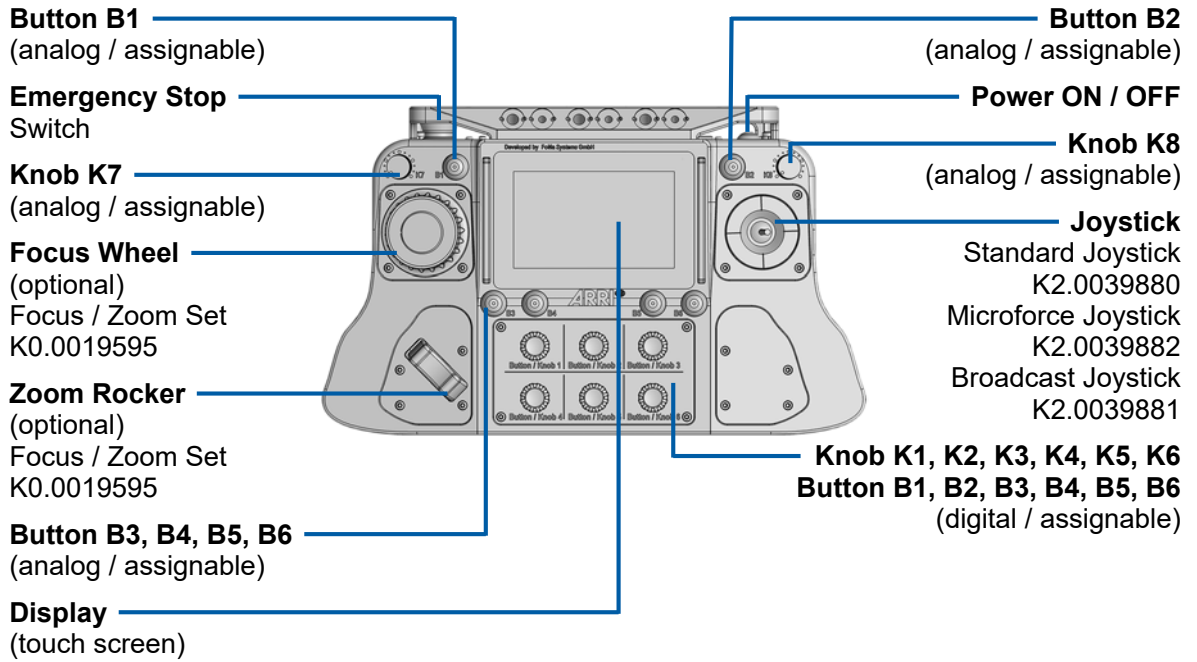

Overview Back

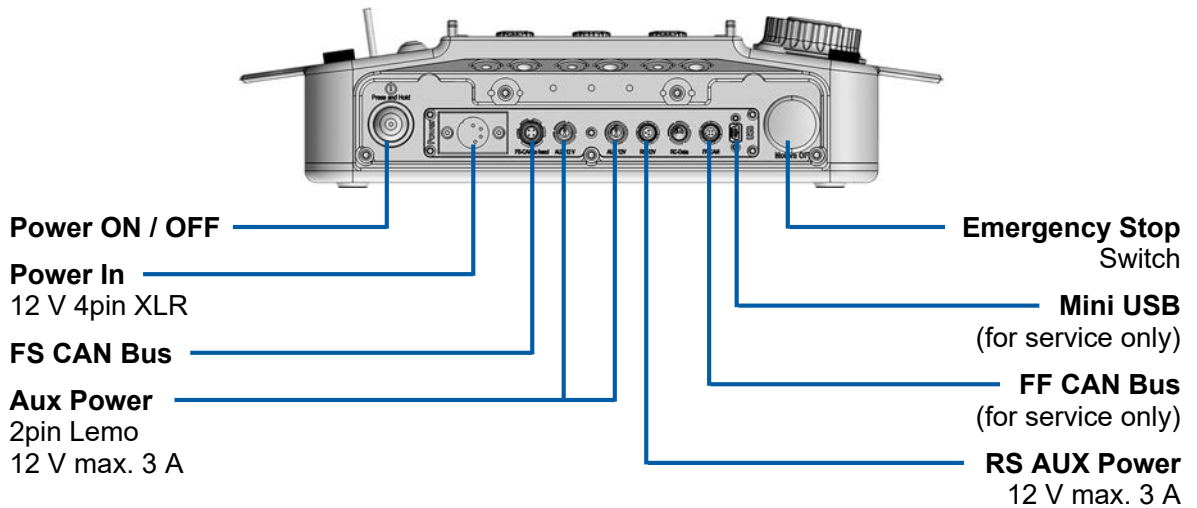

Overview Sides

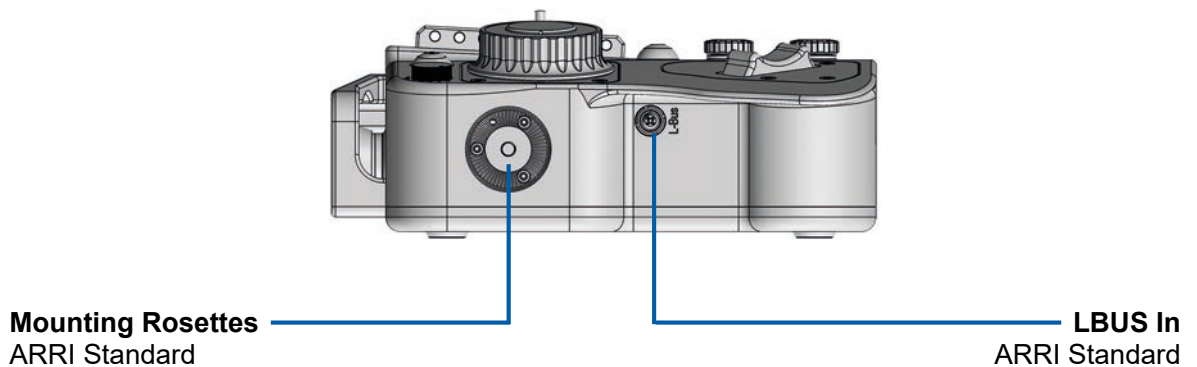

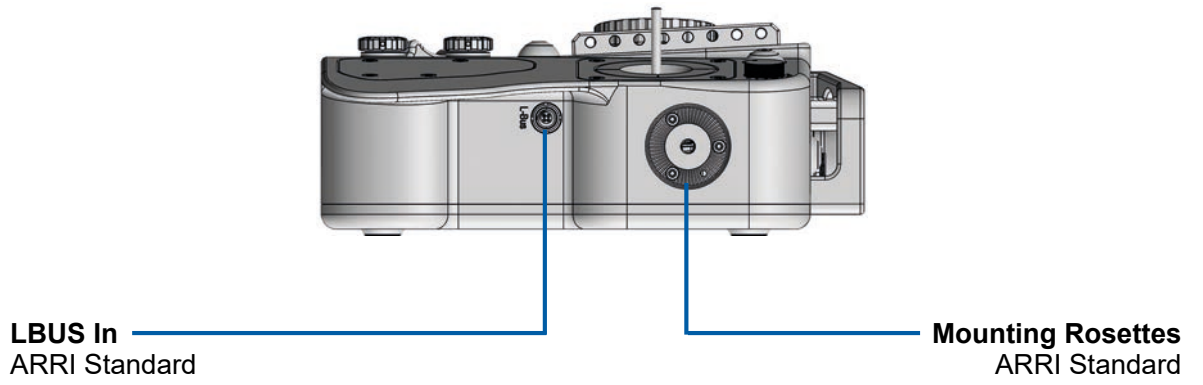

11 Interfaces Remote Control Panel EVP

12 V Power In	XLR 4pin	
LBUS	Lemo 0B 4pin	Data / 12 V max. 3 A
Aux / Tally	Fischer 3pin	12 V max. 3 A
Aux	Lemo 0B 2pin	12 V max. 3 A
FS CAN	Fischer 4pin	Data / 12 V max. 3 A

11.1 Pin Out Remote Control Panel EVP



12 V Power In

XLR 4pin

- Pin 1 Ground
- Pin 2 NC
- Pin 3 NC
- Pin 4 + 12 V

**Shown from mating side*



12 V Aux Power

Lemo 0B 2pin (12 V max. 3 A)

- Pin 1 Ground
- Pin 2 12 V

**Shown from mating side*

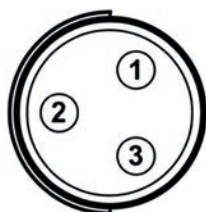

Aux / Tally

Fischer 3pin (12 V max. 3 A)

- Pin 1 Ground
- Pin 2 + 12 V
- Pin 3 Tally

**Shown from mating side*

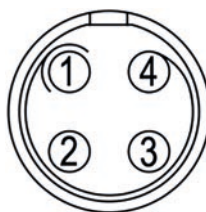

LBUS

Lemo 0B 4pin (24 V max. 3 A)

- Pin 1 Ground
- Pin 2 CAN Low
- Pin 3 + 12 V / + 24 V
- Pin 4 CAN High

**Shown from mating side*

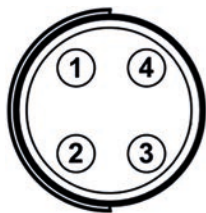

CAN Bus FS

Fischer 4pin (12 V max. 3 A)

- Pin 1 Ground
- Pin 2 CAN 1 Low
- Pin 3 CAN 2 High
- Pin 4 + 12 V

**Shown from mating side*

12 Remote Control Panel / Power Up

12.1 Remote Control Panel Hard Wiring

Use the listed cables to connect the remote control panel with the remote head.

K2.0033762	SRH FS CAN Bus Cable, 1 m / 3.2 ft
K2.0037701	SRH FS CAN Bus Cable, 5 m / 16.4 ft
K2.0019302	SRH FS CAN Bus Cable, 10 m / 32.8 ft
K2.0019301	SRH FS CAN Bus Cable, 25 m / 82 ft
K2.0019300	SRH FS CAN Bus Coupler, 0.2 m / 0.65 ft

12.2 Wireless Application



NOTICE

Availability of Wireless Components

The availability of wireless components may be subject to local laws and restrictions. Not all wireless components might be available in all regions.



If you control the Remote Head wirelessly via the external radio modules, the RCP must be supplied with 12V via the 4-pin XLR power cable.

Order codes of the external radio modules

KK.0040049	ERM-2400 2.4 GHz RXD-TXD Pro Set, SRH
KK.0040050	ERM-900 MHz RXD-TXD Pro Set, SRH

Use the listed cables to connect the remote control panel with the remote head.

K2.0021422	12 V Battery Power Cable, D-Tab, 4-pin XLR, 1.5 m / 5 in
K0.0024196	SRH Power Supply Set for Remote Control Panel, V-Mount
K0.0024195	SRH Power Supply Set for Remote Control Panel, Gold Mount
K2.0048655	BMS-3, Battery Mounting Base, Gen.2, (naked)
K2.0040286	V-Mount for BMS-1 / BMS-2
K2.0040285	Gold Mount for BMS-1 / BMS-2
K2.0040284	B-Mount for BMS-2

13 Emergency Stop

This information appears on the screen after the emergency stop switch has been triggered. The emergency stop switch can be triggered on the remote control panel as well as on the remote control head.

This means that the motors of the remote head are switched off as long as the emergency stop switch is activated.

Remote Head



CAUTION

Always press the emergency stop button and lock TILT when you set up or work on the camera.



NOTICE

An activated emergency stop switch will backlit by a red LED ring. Press the switch to deactivate the emergency stop.

Remote Control Panel

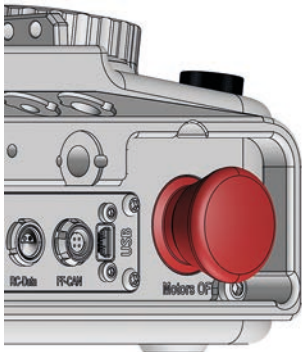

CAUTION

Do not pull the emergency stop button!
Turn the knob to the left to release the knob.

14 Cleaning, Repair and Disposal

Cleaning



NOTICE

Improper Cleaning Procedure

Risk of damage of surfaces.

- ▶ Only use the cleaning agents specified in this section.
- ▶ Do not use any strong or aggressive cleaning detergents like Methanol, Acetone, Benzine or acids. These chemicals may dissolve imprinted labels or the paint on the housing and damage highly polished surfaces.
- ▶ During cleaning of the device, always make sure that protective covers are in place.
- ▶ Do not moisten connectors when cleaning the device.
- ▶ Avoid touching any connector pins when cleaning the device.
- ▶ Avoid wiping dry connector pins with a dry cloth, especially if the surface is not clean.
- ▶ Avoid wiping connector pins without air blow dusting first. If particles or connector pins are electrostatically charged, it may improve dusting efficiency to use deionized air.
- ▶ Compressed air should not be used on the housing.

Recommended Cleaning Agents

- Water
- Glass Cleaner
- Isopropyl Alcohol

Area	Cleaning Procedure
Housing	Clean the housing, mechanical and electronic accessories with a soft, lint free cleaning cloth and some water or glass cleaner. Only when really necessary, e.g. to remove residues of camera tape, isopropyl alcohol should be used.
Narrow spaces and gaps	Use a manual air blower, cotton swabs or a soft brush to remove dust particles from narrow spaces, gaps or connectors.
Ventilation channel	Clean the ventilation channel using a vacuum cleaner at low level.

Repair



WARNING

Repairs carried out by untrained persons

Risk of electric shock and fire hazard caused by short circuit.

- ▶ Do not try to repair the device yourself. Repairs may only be carried out by a certified ARRI service center.

Disposal



NOTICE

You can return the product to the manufacturer Arnold & Richter Cine Technik GmbH & Co. Betriebs KG for disposal.

When you dispose third party accessories, please observe the instructions of the relevant manufacturer.

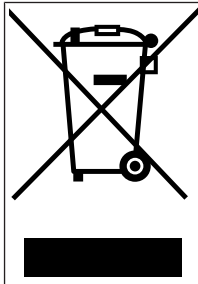

This product falls within the scope of Directive 2012/19 / EU OF THE EUROPEAN PARLIAMENT AND OF THE COUNCIL of June 4, 2012 on waste electrical and electronic equipment (WEEE II).

Accordingly, this product must not be disposed of with household waste. There are the respective country-specific disposal rules that must be observed.

15 Transportation and Storage



NOTICE

Improper Packing and Transportation of the 360 EVO

Risk of damage to the product.

- ▶ Always follow the specified environmental conditions.
- ▶ Always transport the product and accessories in a suitable case.
- ▶ Always follow the instructions for transport and storage described in this section.

The product and its accessories can be damaged if not transported and stored properly. Please take note of the following guidelines.

Transportation Guidelines:

- Remove all accessories from the product.
- Always attach protective caps where applicable.
- Always transport the product in a suitable case.
- Do not subject the product to severe shocks.

Storage Guidelines:

- Remove the all accessories.
- Disconnect all cables and power sources from the product.
- Always store the product in a suitable case.
- Do not store the product outside of the specified ambient temperature range.
- Do not store the product in places where it may be subject to extreme temperatures, direct sunlight, high humidity, severe vibration, dust or strong magnetic fields.

16 ARRI Service Contacts

Please see the current list of service partners at [service contacts](#).



Arnold & Richter Cine Technik GmbH & Co.
Betriebs KG
Herbert-Bayer-Str. 10
80807 Munich
Germany
+49 89 3809 2121
Business hours:
Mo. - Fr. 09:00 - 17:00 (CET)
service@arri.de

ARRI CT Limited / London
2 Highbridge, Oxford Road
UB8 1LX Uxbridge
United Kingdom
+44 1895 457 000
Business hours:
Mo. - Thu. 09:00 am - 5:30 pm (GMT)
Fr. 09:00 am - 5:00 pm (GMT)
service@arri-ct.com

ARRI Inc. / West Coast
3700 Vanowen Street
CA 91505 Burbank
USA
+1 818 841 7070
Business hours:
Mo. - Fr. 09:00 am - 05:00 pm (PT)
service@arri.com

ARRI Inc. / East Coast
617 Route 303
NY 10913 Blauvelt
USA
+1 845 353 1400
Business hours:
Mo. - Fr. 08:00 am - 05:30 pm (EST)
service@arri.com

ARRI Canada Limited
1200 Aerowood Drive, Unit 29
ON L4W 2S7 Mississauga
Canada
+1 416 255 3335
Business hours:
Mo. - Fr. 08:30 am - 05:00 pm (EDT)
service@arri.com

ARRI Australia Pty Ltd
Suite 2, 12B Julius Ave
NSW 2113 North Ryde
Australia
+61 2 9855 4305
Business hours:
Mo. - Fr. 08:00 am - 05:00 pm (AEST)
service@arri.com.au

ARRI Asia Pte. Ltd.
164 Kallang Way, #03-01
349248 Singapore
Singapore
+65 6230 9488
Business hours:
Mo. - Fr. 9:00 - 18:00 (CST)
service@arri.asia

ARRI Japan Kabushiki Kaisha
Service
Haneda Innovation City Zone K210, 1-1-4
Hanedakuko, Ota-Ku
144-0011 Tokyo
Japan
+81 3 6635 3750
Business hours:
Mo. - Fr. 10:00 - 18:00 (JST)
info@arri.jp

ARRI China (Beijing) Co. Ltd.
 Chaowai SOHO Tower C, 6/F, 0628/0656
 Chaowai Dajie Yi 6
 Beijing
 China
 +86 10 5900 9680
 Business hours:
 Mo. - Fr. 09:00 am - 06:00 pm (CST)
 service@arri.cn

ARRI ASIA Limited
 41/F One Kowloon, 1 Wang
 Yuen Street Kowloon Bay
 Hong Kong
 P. R. China
 +852 2537 4266
 Business hours:
 Mo. - Fr. 09:00 am - 06:00 pm (HKT)
 service@arri.asia

ARRI Korea Limited
 Kolon Digital Tower 1(#1505-06), 25
 Seongsuil-ro 4 gil, Seongdong-gu
 04781 Seoul
 Korea
 +82 (0)70 4419 6401
 Business hours:
 Mo. - Fr. 9:00 - 18:00 (KST)
 service@arri.kr

ARRI Brasil Ltda
 Avenida Ibirapuera 2907 – Cj. 421, Indianópolis
 04029-200 São Paulo
 Brazil
 +55 1150419450
 Business hours:
 Mo. - Fr. 09:00 am - 05:30 pm (BRT)
 arribrasil@arri.com

LINKA İthalat İhracat ve Dış Tic.
 Distributor
 Halide Edip Adivar Mah. Darülaceze Cad.
 No:3 Akın Plaza Kat:5 95-96
 34381 Şişli, Istanbul
 Turkey
 +90 2123584520
 Business hours:
 Mo. - Fr. 09:00 - 18:00 (EET)
 service@linkgroup.com.tr

CINEOM Broadcast India Pvt. Ltd.
 C-4, Goldline Business Centre
 Link Rd. Malad West
 400 064 Mumbai
 India
 +91 (0)22 42 10 9000
 Business hours:
 Mo. - Sa. 10:00 am - 06:00 pm (IST)
 arriupportindia@cincom.com

CINEOM Broadcast DMCC.
 Unit No. 2109, Jumeirah Bay Tower X2 Cluster X
 Jumeirah Lakes Towers
 P.O Box 414659
 Dubai, UAE
 +971 (0) 45570477
 Business hours:
 Sa. - Th. 10:00 am- 06:00 pm
 arriervice.me@cincom.com

360 EVO