

SONY

Television

Getting Started [1]

- Using the Help Guide [2]
- Remote control [3]
 - Using the remote control [4]
 - Functions of the remote control buttons [5]
 - Upper buttons on the remote control [6]
 - Lower buttons on the remote control [7]
- Connecting terminal [8]
- Using voice recognition features [9]
 - Using the remote control microphone [10]
- Keeping the TV updated [11]
- Introducing Google TV [12]
 - Installing apps from the Google Play Store [13]
 - Viewing Internet media [14]
 - Enjoying safe apps and video streaming services (Security & Restrictions) [15]
- Basic Operations [16]
 - Home menu [17]
 - Using the Quick Settings [18]
 - Selecting inputs [19]
 - How the LED lights up [20]
- Accessibility features [21]
- Support Site [22]
- Trademark information [23]

Watching TV [24]

- Watching TV programs [25]
 - Using the program guide [26]

Using the TV with Other Devices [27]

- USB devices [28]

- [Playing content stored on a USB device](#) [29]
- [Information about USB devices used for storing photos and music](#) [30]
- [Supported files and formats](#) [31]
 - [Photos](#) [32]
 - [Music](#) [33]
 - [Videos](#) [34]
 - [Audio sampling rates \(for videos\)](#) [35]
 - [External subtitles](#) [36]
- [Blu-ray and DVD players](#) [37]
 - [Connecting a Blu-ray or DVD player](#) [38]
 - [Watching Blu-ray and DVD discs](#) [39]
- [Set-top box \(cable/satellite box\)](#) [40]
 - [Connecting a Set-top box \(cable/satellite box\)](#) [41]
- [Enjoying content from your mobile device on the TV with Google Cast](#) [42]
- [Displaying the iPhone/smartphone or iPad/tablet app screen on the TV](#) [43]
- [Computers, cameras, and camcorders](#) [44]
 - [Connecting a computer and viewing stored content](#) [45]
 - [Connecting a camera or camcorder and viewing stored content](#) [46]
 - [Computer video signal specifications](#) [47]
- [Audio system](#) [48]
 - [Outputting audio from an audio system](#) [49]
 - [Connecting an audio system](#) [50]
 - [Adjusting an audio system](#) [51]
 - [Pass-through audio formats supported with eARC \(only models equipped with an HDMI IN \(eARC/ARC\) terminal\)](#) [52]
- [Bluetooth devices](#) [53]
 - [Connecting a Bluetooth device](#) [54]
 - [Supported Bluetooth profiles](#) [55]
- [CEC-compatible devices](#) [56]
 - [CEC overview](#) [57]
 - [Using features available for CEC-compatible devices](#) [58]
 - [Adjusting HDMI CEC settings](#) [59]
- [Viewing pictures in 4K from compatible devices](#) [60]
 - [Viewing pictures in 4K resolution](#) [61]
 - [Settings for viewing pictures in 4K resolution with higher quality](#) [62]

Connecting to a Network [63]

- Connecting to a network using a LAN cable [64]
- Connecting to a network using a wireless connection [65]
 - Using Wi-Fi to connect the TV to the Internet/Network [66]

Configuring the TV [67]

- [Settings] [68]
 - [Channels & Inputs] [69]
 - [Display & Sound] [70]
 - "Picture adjustments" advanced settings [71]
 - "Sound adjustments" advanced settings [72]
 - [Network & Internet] [73]
 - [Accounts & sign-in] [74]
 - [Privacy] [75]
 - [Apps] [76]
 - [System] [77]
 - [Remotes & Accessories] [78]
 - [Help & Feedback] [79]

Troubleshooting [80]

- Start here [81]
 - Software updates [82]
 - If a full reset (restart) of the TV is required [83]
 - Frequently Asked Questions for Troubleshooting [84]
- Picture (quality)/screen [85]
 - No color/Dark picture/Color is not correct/Picture is too bright. [86]
 - Distorted picture./The screen flickers. [87]
 - Picture size/Screen format/Wide mode changes automatically. [88]
 - A black box appears on the screen. [89]
 - High resolution HDR pictures are not displayed. [90]
 - A message about an app asking for permission to access a TV function is displayed. [91]
- Keyboard [92]
- Broadcast reception [93]
 - Check these things first to troubleshoot your TV reception. [94]

- Block noise or an error message appears and you cannot watch broadcasts. [95]
- Ghosting or double images appear. [96]
- Only snow noise or a black picture appears on the screen. [97]
- There is picture or sound noise when viewing an analog TV channel. [98]
- Some channels are blank. [99]
- Poor reception or poor picture quality with digital broadcasts. [100]
- You cannot view digital channels. [101]
- You cannot receive or select channels. [102]
- Some digital cable channels are not displayed. [103]
- Broadcast HD formats have poor quality. [104]
- Sound [105]
 - No sound but good picture. [106]
 - Audio noise. [107]
 - No audio or low audio with a home theater system. [108]
 - Distorted sound. [109]
 - You want to output sound from the headphones/Bluetooth audio device and audio system/TV speakers at the same time. [110]
 - You are concerned about a delay between the picture and sound. [111]
 - You cannot establish an eARC connection (only models equipped with an HDMI IN (eARC/ARC) terminal). [112]
- Network (Internet)/apps [113]
 - The TV cannot connect to the Internet/Network. [114]
 - The picture and/or sound quality from streaming apps is poor. [115]
 - You can connect to the Internet, but not to certain apps and services. [116]
- Remote control/accessories [117]
 - The remote control does not operate. [118]
- Power [119]
 - The TV turns off automatically. [120]
 - The TV turns on automatically. [121]
 - The TV does not turn on. [122]
- Connected devices [123]
 - No picture from a connected device. [124]
 - Certain programs on digital sources display a loss of detail. [125]
 - Photo images or folders take time to display. [126]
 - You cannot find a connected HDMI CEC device. [127]

- [Some media files in the USB device are not displayed.](#) [128]
- [Operation cuts out, or a device does not work.](#) [129]
- [Some paid content cannot be played.](#) [130]
- [LED](#) [131]
 - [The illumination LED sometimes lights up.](#) [132]

[Index](#) [133]

[1]

Getting Started

[Using the Help Guide](#)

[Remote control](#)

[Connecting terminal](#)

[Using voice recognition features](#)

[Keeping the TV updated \(Only on limited region/country/TV model\)](#)

[Introducing Google TV](#)

[Basic Operations](#)

[Accessibility features](#)

[Support Site](#)

[Trademark information](#)

[2] Getting Started

Using the Help Guide

This Help Guide explains how to use this TV. You can also refer to the Setup Guide for descriptions about TV installation, and the Reference Guide for parts descriptions, specifications, and wall mounting of this TV.

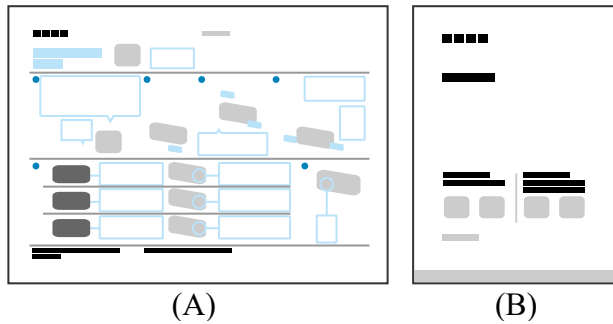

(A)

(B)

(A) Setup Guide

(B) Reference Guide

Help Guide versions

There are two versions of the Help Guide: the built-in version and the online version. The online Help Guide includes the latest information.

The online Help Guide is automatically displayed when the TV is connected to the internet, otherwise the built-in Help Guide is displayed.



In this Help Guide, you can read the desired information in order or search for it directly. To search, select  at the top of the screen.

Note

- To use the latest features described in the Help Guide, you may need to update the TV's software. For details about software updates, see the [Software updates](#) page.
- The names of settings in the Help Guide may differ from those displayed on the TV depending on the TV's release date or your model/country/region.
- The images and illustrations used in the Help Guide may differ depending on your TV model.
- Design and specifications are subject to change without notice.

Hint

- To see if your TV is equipped with one of the functions described in the Help Guide, refer to the paper manual or a Sony product catalog.

- This Help Guide is written for all regions/countries. Some descriptions contained in this Help Guide do not apply to some regions and countries.

Related topics

- [Connecting to a network using a LAN cable](#)
- [Using Wi-Fi to connect the TV to the Internet/Network](#)

[3] Getting Started

Remote control

[Using the remote control](#)

[Functions of the remote control buttons](#)

[4] Getting Started | Remote control

Using the remote control

You can operate many of the TV's features by using the ▲ (Up) / ▼ (Down) / ◀ (Left) / ▶ (Right) and ⏏ (Enter) buttons.

The included remote control varies depending on your model. For descriptions of the remote control buttons, refer to the [Functions of the remote control buttons](#).

- 1 Use the ▲ (Up), ▼ (Down), ◀ (Left) and ▶ (Right) buttons to “focus” on the desired item.

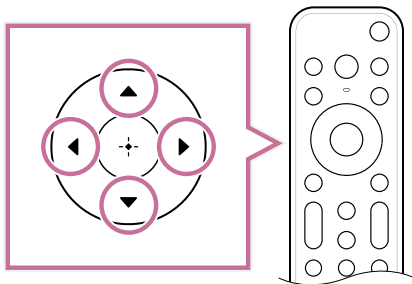

2 Press the center of the (Enter) button to select the item currently in focus.

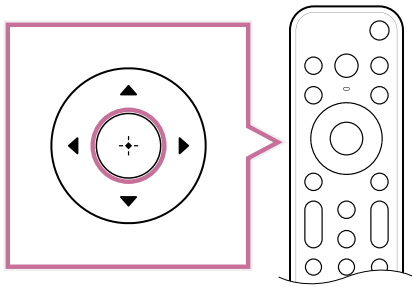

To return to the previous screen

Press the  (Back) button.

Hint

- For other information, see the related topics below or “Frequently Asked Questions” on the Sony Support Site.

[Frequently Asked Questions for Troubleshooting](#)

Related topics

- [Functions of the remote control buttons](#)
- [Using the remote control microphone](#)
- [The remote control does not operate.](#)
- [Connecting to a Network](#)

[5] Getting Started | Remote control

Functions of the remote control buttons

[Upper buttons on the remote control](#)

[Lower buttons on the remote control](#)

[6] Getting Started | Remote control | Functions of the remote control buttons

Upper buttons on the remote control

The included remote control, as well as the layout of the buttons, the button names and the button icons, vary depending on your model/country/region.

- Lower buttons on the remote control



⏻ (Power)

Turns on or switches to standby/networked standby mode.

TV

Switch to a TV channel or input and display the TV menu.
For details, refer to the [Selecting inputs](#) page.

⏪ (MIC)

For voice search, refer to the [Using the remote control microphone](#) page.

🔑 (Quick Settings)

Display Quick Settings. For details, refer to the [Using the Quick Settings](#) page.

↶ (Input)

Display and select the input source, etc. For details, refer to the [Selecting inputs](#) page.

MENU (Control menu)

Display the Control menu.

▲ (Up) / ▼ (Down) / ◀ (Left) / ▶ (Right) / ⏏ (Enter) (Navigation D-Pad)

On screen menu navigation and selection.

In TV mode: Display and select programs on other channels while watching TV (Digital/Analog).

↶ (Back)

Return to the previous screen.

🏠 (Home)

Display the TV Home Menu. For details, refer to the [Home menu](#) page.

Lower buttons on the remote control

The included remote control, as well as the layout of the buttons, the button names and the button icons, vary depending on your model/country/region.

- [Upper buttons on the remote control](#)

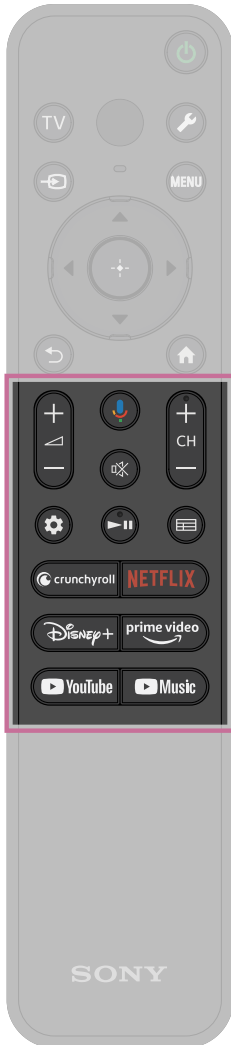

(Google Assistant / Microphone)

Ask Google for a little help on the big screen.

Press the Google Assistant (or MIC) button on the remote to get started.

For details, refer to the [Using the remote control microphone](#) page.

Google Assistant is not available in certain languages/countries/regions.

+/- (Volume)

Adjust the volume.

(Mute)

Mute the sound. Press again to restore the sound.

Hint

- The accessibility shortcut service can be turned on or off by pressing and holding  (Mute).

CH +/- (Channel)

Select the channel.

(Dashboard)

Display Dashboard.

(Play / Pause)

Operate media contents on the TV and connected CEC-compatible device.

(Guide)

Display the digital program guide of the TV or cable/satellite box. For details, refer to the [Using the program guide](#) page.

App buttons (Only on limited region/country/TV model)





Enjoy various video streaming services with one push.

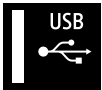

Press to watch your desired service.

[8] Getting Started

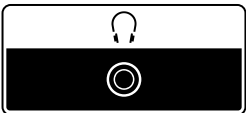
Connecting terminal

The types and shapes of connectors availability vary depending on your TV. For the location of the connectors, refer to the Setup Guide (printed manual).

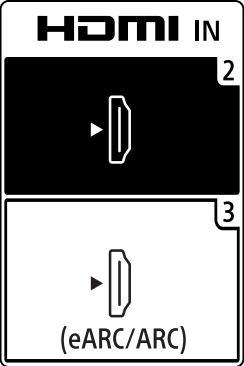
Terminal	Description
	<p>USB</p> <p>Connects to Digital still camera/Camcorder/USB storage media.</p> <p>Note</p> <ul style="list-style-type: none"> Connects a large USB device may interfere with other connected devices beside it. In such case, connect to the other USB port.
	<p>VIDEO IN</p> <p>Connects to VCR/Video game equipment/DVD player/Camcorder.</p> <p>For a composite connection, refer to Connecting a Blu-ray or DVD player.</p>
	<p> (Headphone)</p> <p>Connects to the headphone jack to listen to sound from the TV. Supports 3-pole stereo mini jack only.</p> <p>Note</p>

Terminal	Description
	<ul style="list-style-type: none"> You cannot output sound from both the headphone and the TV speakers at the same time.
	<p>HDMI IN</p> <p>Connects to HDMI device. HDMI interface can transfer the digital video and audio on a single cable. To enjoy high quality 4K contents, connect a Premium High Speed HDMI™ Cable(s) and set the [HDMI signal format] to [Enhanced format]/[Enhanced format (ALLM)].</p>
	<p>HDMI IN (eARC/ARC) / HDMI IN (ARC)</p> <p>Connects your audio system that supports eARC (Enhanced Audio Return Channel) or ARC (Audio Return Channel) to the HDMI IN (eARC/ARC) or HDMI IN (ARC) to route TV audio to your audio system. It is a feature that sends audio to an audio system that supports eARC/ARC through an HDMI cable. If the audio system does not support eARC/ARC, you need to connect with DIGITAL AUDIO OUT (OPTICAL).</p>
	<p>DIGITAL AUDIO OUT (OPTICAL)</p> <p>Connects to the audio system with optical audio input. When connecting an audio system not compatible with ARC using an HDMI cable, you need to connect an optical audio cable to the DIGITAL AUDIO OUT (OPTICAL) to output digital sound.</p>
	<p>⏏ (Cable/Antenna input)</p> <p>Connects to Cable/Antenna/External Box.</p>

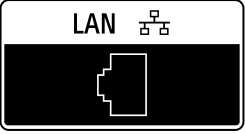
Terminal	Description
	<p>LAN</p> <p>Connect to Router.</p> <p>Connects to the Internet using a LAN cable.</p>

[9] Getting Started

Using voice recognition features

Using the remote control microphone This feature is available for TVs in which the included remote control has a Google Assistant (or MIC) button.

[10] Getting Started | Using voice recognition features

Using the remote control microphone

Remote controls that support Voice search have a Google Assistant button and a built-in microphone. By speaking into the microphone, you can search for various content.

1 Press and hold the Google Assistant button on your remote control.

The microphone on the remote control will be activated while the button is pressed, and the LED on the remote control will light up.

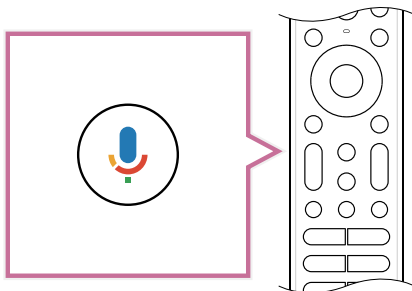

2 Speak into the microphone while pressing and holding the Google Assistant button.

Speech examples may be displayed depending on your model.



Search results are displayed when you speak into the microphone.

When you cannot search using your voice

Register the voice remote control that has the Google Assistant button to the TV again by pressing the  (Quick Settings) button on the remote control and selecting [Settings] — [Remotes & Accessories] — [Remote control] — [Connect via Bluetooth].

Note

- An Internet connection and Google account are required to use Voice search.
- The type of remote control supplied with the TV, and the availability of a remote control with a built-in microphone varies depending on your model/region/country. An optional remote control is available in some models/regions/countries.
- To use the microphone on the remote control, you must add and set a Google Account to the TV.

[11] Getting Started

Keeping the TV updated

(Only on limited region/country/TV model)

The TV acquires data such as program guides while it is in standby mode. To keep your TV updated, we recommend that you turn off the TV normally by using the power button on the remote control or TV.

[12] Getting Started

Introducing Google TV

[Installing apps from the Google Play Store](#)

[Viewing Internet media](#)

[Enjoying safe apps and video streaming services \(Security & Restrictions\)](#)

[13] Getting Started | Introducing Google TV

Installing apps from the Google Play Store

You can install apps from the Google Play Store to the TV, just like you do with smartphones and tablets.

Note

- You can only install apps that are compatible with TVs. They may differ from apps for smartphones/tablets.
- An Internet connection and Google account are required to install apps from the Google Play Store.

Hint

- If you do not have a Google account or want to create a shared account, create a new account by accessing the following website.

<https://accounts.google.com/signup>

The website above may vary depending on your region/country. It is also subject to change without notice. For details, refer to the Google homepage.

- We recommend that you create a Google account on a computer or mobile device.

1 Press the  (Home) button, and from [Search] on the Home screen, say something like “Search for <app name> apps” to search for apps you want to install. Alternatively, select the input field and use the on-screen keyboard.

2 Select an app from the search results and install it.

Hint

- If the app search does not produce the desired results, say “Google Play Store”, and try searching for the app on the Google Play Store screen.

- You can also select a category from the Apps tab in the Home Menu and select a desired app.

After downloading, the app is automatically installed and added. You can select [Open] to launch the app.

Hint

- To start an installed app later, select the Apps tab in the Home Menu, and select [See all] at the right edge of the app area. Select the installed app to start it.

About paid apps

There are free apps and paid apps in the Google Play Store. To purchase a paid app, a prepaid Google Play gift card code or credit card information is required. You can purchase a Google Play gift card from various retailers.

To delete an app

- 1 Press the  (Quick Settings) button on the remote control, select [Settings] — [Apps], select an app to be deleted, and uninstall it.

Related topics

- [Connecting to a network using a LAN cable](#)
- [Using Wi-Fi to connect the TV to the Internet/Network](#)

[14] Getting Started | Introducing Google TV

Viewing Internet media

You can use video streaming services such as YouTube and Netflix to watch Internet content. The available services vary depending on your country and region. You can launch these services by selecting their tiles in the Home Menu.

Note

- An Internet connection is required to watch Internet content.

Related topics

- [Enjoying safe apps and video streaming services \(Security & Restrictions\)](#)
- [Connecting to a network using a LAN cable](#)
- [Using Wi-Fi to connect the TV to the Internet/Network](#)
- [Home menu](#)

[15] Getting Started | Introducing Google TV

Enjoying safe apps and video streaming services (Security & Restrictions)

You can ensure safe use of the TV by setting installation restrictions on apps that are downloaded from unknown sources, or age restrictions on programs and videos.

- 1 Press the  (Quick Settings) button on the remote control, then select [Settings] — [Apps] — [Security & Restrictions].

Note

- If you change the [Security & Restrictions] settings, your device and personal data are more vulnerable to attack by unknown apps from sources other than Play Store. You agree that you are solely responsible for any damage to your device or loss of data that may result from using these apps.

Hint

- Other separate restrictions may be available depending on the app. For details, refer to the app's Help.

[16] Getting Started

Basic Operations

[Home menu](#)

[Using the Quick Settings](#)

[Selecting inputs](#)

How the LED lights up

[17] Getting Started | Basic Operations

Home menu

The screen displayed when you press the **🏠** (Home) button on the remote control is called the Home Menu. From the Home Menu, you can search for content and select recommended content, apps, and settings.

The displayed Home Menu depends on whether a Google Account is added to the TV. (Some features do not apply depending on your model/region/country. The images are for reference only. They may differ from the actual screen.)

(A) The Home Menu when a Google Account is set on the TV

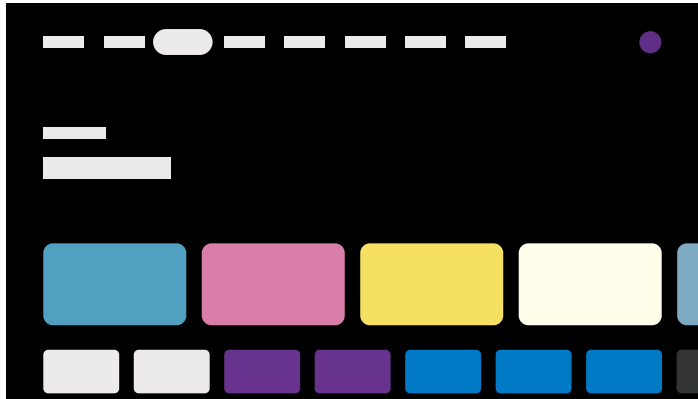

(B) The Home Menu when a Google Account is not set on the TV



Setting a Google Account and enjoying the TV

If you connect the TV to the Internet and set a Google Account, you can install desired apps on the TV and enjoy Internet videos or use your voice to search for content.

Enjoying the TV without setting a Google Account

Even if you do not set a Google Account, you can watch TV broadcasts or connect devices such as Blu-ray player. If you connect the TV to the Internet, you can also use the Internet streaming services displayed in the Home Menu.

Note

- To set a Google Account later and enjoy the TV, set up Google TV from the Home Menu or settings menu.
- If you delete the Google Account, the TV will return to the factory default settings.

Hint

- Depending on the TV settings, the Home screen will be displayed when the TV is turned on. If you change the following setting, you can change the screen that is displayed when the TV is turned on to the TV broadcast channel or external input such as HDMI that you were watching before turning off the TV.

- 1 Press the  (Quick Settings) button on the remote control, then select [Settings] — [System] — [Power and Energy].**
- 2 Select [Power on behavior], and then select [Last input].**

The next time the TV is turned on, the TV broadcast channel or external input such as HDMI that you were watching before turning off the TV will be displayed.

Specifications may be subject to change without notice.

- For other information, see “Frequently Asked Questions” on the Sony Support Site. [Frequently Asked Questions for Troubleshooting](#)

[18] Getting Started | Basic Operations

Using the Quick Settings

If you press the  (Quick Settings) button on the remote control, you can quickly access features such as [Picture mode], [Sleep timer], and [Picture Off] on the current screen, and settings such as [Speakers] depending on the connected devices. You can also display [Settings] from [Quick Settings].

Note

- The menus displayed in the TV settings vary depending on your model/region/country.

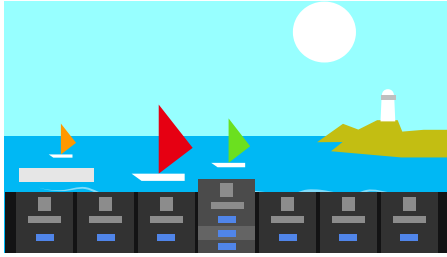





- 1 Press the  (Quick Settings) button on the remote control.
- 2 Move the focus to change a setting or select it.

[19] Getting Started | Basic Operations

Selecting inputs





To use devices (such as a Blu-ray/DVD player or USB flash drive) connected to the TV, or to watch TV after such use, you will need to switch the input.

- 1 Press the  (Input) button repeatedly to select the connected device. Alternatively, press the  (Input) button, use the  (Left) /  (Right) buttons to select a connected device, and then press the  (Enter) button.





Note

- If there are no devices connected to an HDMI input, the HDMI input may not be displayed in the [Input menu].

To edit the input items

- 1 Press the  (Input) button.
- 2 Press the  (Right) button (or  (Left) button depending on the TV's display language) and select  (Edit).

3 Select the input/device you want to show or hide.**4 Select [Close].****Hint**

- To change the order or hide a displayed item, press and hold the  (Enter) button on the remote control with that item highlighted, and [Move] and [Hide] will be displayed. If you select [Move], use  (Left) /  (Right) on the remote control to move the item to the desired position, and then press the  (Enter) button on the remote control.
- You can switch to TV broadcasting by simply pressing the TV button on the remote control.

[20] Getting Started | Basic Operations

How the LED lights up

Certain colors will appear at the bottom center of your TV indicating a certain activity or status.

Illumination LED

 <p>White “on” or “blinking”</p>	<ul style="list-style-type: none"> • When the TV is turning on • When receiving signals from the remote control • When updating the software <p>etc.</p>
---	---

Related topics

- [Software updates](#)

[21] Getting Started

Accessibility features

This TV has accessibility features in [Accessibility] such as a text-to-speech function for on-screen text, zooming to make text easier to read, and subtitles/captions.

Press the  (Quick Settings) button on the remote control, then select [Settings] — [System] — [Accessibility] to configure the user assistive features.

[Accessibility] has a shortcut function so you can turn it on or off by pressing and holding the  (Mute) button on the remote control for 3 seconds.

Hint

- The default setting for the function that operates when you press and hold the  (Mute) button on the remote control for 3 seconds is [TalkBack]. Enable the function using [Accessibility shortcut] in [Accessibility], and change the assigned feature using [Shortcut service].
- To use text-to-speech with the Help Guide, view the Help Guide in the Sony support website using a computer or smartphone.
 - USA:
<https://www.sony.com/tvsupport>
 - Canada:
<https://www.sony.ca/support>
 - Brazil:
<https://esupport.sony.com/BR/>
 - Latin America:
<https://esupport.sony.com/ES/LA/>
 - Philippines:
<https://www.sony-asia.com/support/>

[22] Getting Started

Support Site

For the latest information and Online Help Guide, please visit the Sony support website:

- USA:
<https://www.sony.com/tvsupport>
- Canada:
<https://www.sony.ca/support>
- Brazil:
<https://esupport.sony.com/BR/>

- Latin America:
<https://esupport.sony.com/ES/LA/>
- Philippines:
<https://www.sony-asia.com/support/>

[23] Getting Started

Trademark information



- Vewd[®] Core. Copyright 1995-2023 Vewd Software AS. All rights reserved.



- The Bluetooth[®] word mark and logos are registered trademarks owned by Bluetooth SIG, Inc. and any use of such marks by Sony Group Corporation and its subsidiaries is under license.



- Covered by one or more claims of the HEVC patents listed at patentlist.accessadvance.com.
- Wi-Fi[®], Wi-Fi Alliance[®] and Wi-Fi Direct[®] are registered trademarks of Wi-Fi Alliance.

- Wi-Fi CERTIFIED™ and Wi-Fi CERTIFIED 6™ logos are certification marks of Wi-Fi Alliance.
- Disney+ and all related logos and marks are trademarks of Disney Enterprises, Inc. or its affiliates.
- Amazon, Prime Video and all related logos are trademarks of Amazon.com, Inc. or its affiliates.
- Apple, Apple Home, AirPlay and HomeKit are trademarks of Apple Inc., registered in the U.S. and other countries and regions.
To use AirPlay and Apple HomeKit with this TV, the latest version of iOS, iPadOS, or macOS is recommended.
- “BRAVIA”, BRAVIA and BRAVIA Sync are trademarks or registered marks of Sony Group Corporation or its affiliates.
- All other trademarks are the property of their respective owners.

Note

- The availability of each service depends on your region/country.

[24]

Watching TV

[Watching TV programs](#)

[25] Watching TV

Watching TV programs

[Using the program guide](#)

[26] Watching TV | Watching TV programs

Using the program guide

You can quickly find your preferred programs.

- 1 Press the  (Guide) button to display the program guide of a related channels service while it is running, for example digital TV (broadcast).

[27]

Using the TV with Other Devices

[USB devices](#)

[Blu-ray and DVD players](#)

[Set-top box \(cable/satellite box\)](#)

[Enjoying content from your mobile device on the TV with Google Cast](#)

[Displaying the iPhone/smartphone or iPad/tablet app screen on the TV](#)

[Computers, cameras, and camcorders](#)

[Audio system](#)

[Bluetooth devices](#)

[CEC-compatible devices](#)

[Viewing pictures in 4K from compatible devices](#)

[28] Using the TV with Other Devices

USB devices

[Playing content stored on a USB device](#)

[Information about USB devices used for storing photos and music](#)

[Supported files and formats](#)

[29] Using the TV with Other Devices | USB devices

Playing content stored on a USB device

Connecting a USB device

Connect a USB storage device to the USB port of the TV to enjoy photo, music, and video files stored on the device.

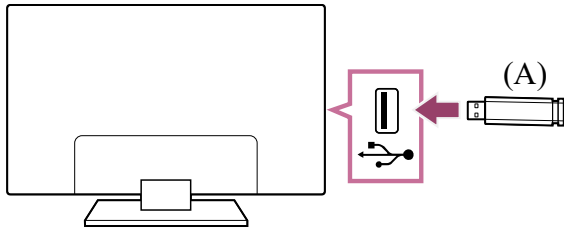

(A) USB storage device

Enjoy photos/music/movies stored on a USB device

You can enjoy photos/music/movies stored on a USB device on the TV screen.

- 1 **If the USB device connected to the TV has a power switch, turn it on.**
- 2 **Press the  (Home) button, select Apps from the Home menu, and select [Media Player] to view photos [Album], play music [Music], or play movies [Video].**
- 3 **Select the USB device and browse the list of folders and files, then select the desired file.**

Playback starts.

To check the supported file formats

- [Supported files and formats](#)

Note

- Depending on the image dimension, file size, and number of files in a folder, some photo images or folders take time to display.
- Displaying the USB device may take some time because the TV accesses the USB device every time the USB device is connected.
- All USB ports on the TV support Hi-Speed USB. USB hubs are not supported.
- While accessing the USB device, do not turn off the TV or USB device, and do not disconnect the USB cable. Otherwise, data stored on the USB device may be corrupted.

- Depending on the file, playback may not be possible, even when using the supported formats.

Hint

- For other information, see “Frequently Asked Questions” on the Sony Support Site. [Frequently Asked Questions for Troubleshooting](#)

Related topics

- [Information about USB devices used for storing photos and music](#)
- [No picture from a connected device.](#)

[30] Using the TV with Other Devices | USB devices

Information about USB devices used for storing photos and music

- The USB ports on the TV support FAT16, FAT32 and NTFS file systems.
- When connecting a Sony digital still camera to the TV with a USB cable, USB connection settings on your camera need to be set to “Auto” or “Mass Storage” mode.
- If your digital still camera does not work with your TV, try the following:
 - Set the USB connection settings on your camera to “Mass Storage”.
 - Copy the files from the camera to a USB flash drive, then connect the drive to the TV.
- Some photos and movies may be magnified, resulting in low picture quality. Depending on the size and aspect ratio, images may not be displayed in full screen.
- It may take a long time to display a photo, depending on the file or settings.
- In no event shall Sony be liable for recording failure or any damage or loss of recorded contents caused or associated with the TV’s malfunction, the USB device’s malfunction, or any other problem.

Related topics

- [Supported files and formats](#)

[31] Using the TV with Other Devices | USB devices

Supported files and formats

[Photos](#)

[Music](#)

[Videos](#)

[Audio sampling rates \(for videos\)](#)

[External subtitles](#)

[32] Using the TV with Other Devices | USB devices | Supported files and formats

Photos

Use case : USB

File Format	Extension
JPEG	*.jpg
BMP	*.bmp
PNG	*.png
GIF	*.gif
TIFF	*.tiff

Other supported files and formats

- [Music](#)
- [Videos](#)
- [Audio sampling rates \(for videos\)](#)
- [External subtitles](#)

[33] Using the TV with Other Devices | USB devices | Supported files and formats

Music

Use case : USB

Extension: *.mp3

Description	Sampling Rate
MP1L3	32k / 44.1k / 48k
MP2L3	16k / 22.05k / 24k
MP2.5L3	8k / 11.025k / 12k

Other supported files and formats

- [Photos](#)
- [Videos](#)
- [Audio sampling rates \(for videos\)](#)
- [External subtitles](#)

[34] Using the TV with Other Devices | USB devices | Supported files and formats

Videos

Use case : USB

AVI (*.avi)

Subtitle Type : External

Video Codec (Profile@Level)	Audio Codec	Max. / Min. Resolution ^{*1}	Max. Frame Rate
MPEG1	PCM, ADPCM, MPEG, Dolby AC3, WMA	1920x1080 / –	1920x1080@60fps
MPEG2 MP@HL	PCM, MPEG, Dolby AC3, AAC, WMA	1920x1080 / –	1920x1080@60fps
H.264 MP LV 4.0	MPEG, AAC, WMA	1920x1080 / –	1920x1080@60fps

Video Codec (Profile@Level)	Audio Codec	Max. / Min. Resolution^{*1}	Max. Frame Rate
H.264 HP LV 4.0	MPEG, Dolby AC3, AAC, WMA	1920x1080 / –	1920x1080@60fps
MPEG-4 SP@HL 3.0	MPEG, Dolby AC3, WMA	1920x1080 / –	1920x1080@60fps
MPEG-4 ASP@HL 4.0	MPEG, Dolby AC3	1920x1080 / –	1920x1080@60fps
Motion JPEG	PCM, ADPCM, MPEG, Dolby AC3, AAC	1920x1080 / –	1920x1080@60fps
H.264 BP LV 4.0	PCM, Dolby AC3, AAC, WMA	1920x1080 / –	1920x1080@30fps

ASF (*.wmv, *.asf)

Subtitle Type : External

Video Codec (Profile@Level)	Audio Codec	Max. / Min. Resolution^{*1}	Max. Frame Rate
Window Media Video v9	WMA	1920x1080 / –	1920x1080@60fps
MPEG-4 SP@HL 3.0	MPEG	1920x1080 / –	1920x1080@60fps
VC-1	WMA	1920x1080 / –	1920x1080@60fps

MP4 (*.mp4, *.mov, *.3gp)

Subtitle Type : External

Video Codec (Profile@Level)	Audio Codec	Max. / Min. Resolution^{*1}	Max. Frame Rate
H.264 BP LV 4.0	AAC, MPEG Layer 3	1920x1080 / –	1920x1080@30fps
H.264 MP LV 4.0	AAC	1920x1080 / –	1920x1080@60fps
H.264 HP LV 4.0	AAC, MPEG Layer 3	1920x1080 / –	1920x1080@60fps
H.265 Main profile @ Level 4.1	AAC, Dolby AC3, MPEG Layer 3	1920x1080 / –	1920x1080@60fps
MPEG-4 SP@HL 3.0	AAC, MPEG Layer 3	1920x1080 / –	1920x1080@60fps
MPEG-4 ASP@HL 4.0	AAC, Dolby AC3, MPEG Layer 3	1920x1080 / –	1920x1080@60fps
H.264 HP LV 5.1	AAC	4096x2160 / –	4096x2160@30fps
H.265 Main10 profile @ Level 5.1	AAC, Dolby AC3, MPEG Layer 3	4096x2160 / –	4096x2160@60fps
AV1	Dolby AC3	3840x2160 / 720x480	3840x2160@60fps

PS (Program Stream) (*.mpg, *.mpeg, *.vob)

Subtitle Type : External

Video Codec (Profile@Level)	Audio Codec	Max. / Min. Resolution^{*1}	Max. Frame Rate
MPEG1	MPEG Layer 1/2, MP3, AC3 [Dolby	1920x1080 / –	1920x1080@60fps

Video Codec (Profile@Level)	Audio Codec	Max. / Min. Resolution^{*1}	Max. Frame Rate
	Digital], E-AC3 [Dolby Digital Plus]		
MPEG2 MP@HL	MPEG Layer 1/2, MP3, AC3 [Dolby Digital], E-AC3 [Dolby Digital Plus]	1920x1080 / –	1920x1080@60fps

TS (Transport Stream) (Others (*.ts))

Subtitle Type : External

Video Codec (Profile@Level)	Audio Codec	Max. / Min. Resolution^{*1}	Max. Frame Rate
MPEG2 MP@HL	Dolby AC3, MPEG, AAC	1920x1080 / –	1920x1080@60fps
H.264 MP LV 4.0	MPEG, AAC	1920x1080 / –	1920x1080@60fps
H.264 HP LV 4.0	Dolby AC3, MPEG, AAC	1920x1080 / –	1920x1080@60fps
H.264 MVC	Dolby AC3, MPEG, AAC	1920x1080 / –	1920x1080@60fps
H.264 BP LV 4.0	Dolby AC3, MPEG	1920x1080 / –	1920x1080@30fps
H.264 HP LV 5.1	MPEG	4096x2304 / –	4096x2304@30fps

FLV (*.FLV)

Subtitle Type : External

Video Codec (Profile@Level)	Audio Codec	Max. / Min. Resolution *1	Max. Frame Rate
Sorenson	PCM, MPEG, AAC	352x288 / –	352x288@30fps
H.264 BP LV 4.0	PCM, MPEG, AAC	1920x1080 / –	1920x1080@30fps
H.264 MP LV 4.0	MPEG, AAC	1920x1080 / –	1920x1080@60fps
H.264 HP LV 4.0	PCM, MPEG, AAC	1920x1080 / –	1920x1080@60fps

TS (*.VP9)

Subtitle Type : External

Video Codec (Profile@Level)	Audio Codec	Max. / Min. Resolution *1	Max. Frame Rate
VP9	VORBIS	4196x2160 / –	4196x2160@60fps

MKV (*.mkv)

Subtitle Type : External

Video Codec (Profile@Level)	Audio Codec	Max. / Min. Resolution *1	Max. Frame Rate
MPEG4*3	PCM, MPEG1 Layer1/2, MPEG4 HE-AAC, AC3 [Dolby Digital], FLAC	1920x1080 / –	1920x1080@60fps

Video Codec (Profile@Level)	Audio Codec	Max. / Min. Resolution*¹	Max. Frame Rate
H.264*1	PCM, MPEG1 Layer1/2, MP3, MPEG2 AAC, MPEG4 AAC, MPEG4 HE-AAC, AC3 [Dolby Digital]	1920x1080 / –	1920x1080@60fps
VC-1	PCM, MPEG1 Layer1/2, MP3, MPEG4 AAC, MPEG4 HE-AAC	1920x1080 / –	1920x1080@60fps
VP8	VORBIS	4196x2160 / –	4196x2160@60fps
H.264 HP LV 4.2	MP3, MPEG2 AAC, AC3 [Dolby Digital]	1920x1080 / –	1920x1080@60fps

WebM (*.webm)

Subtitle Type : External

Video Codec (Profile@Level)	Audio Codec	Max. / Min. Resolution*¹	Max. Frame Rate
AV1	OPUS	3840x2160 / 720x480	3840x2160@60fps

*¹ For 2K Models, the maximum resolution is limited to 1920x1080.

Other supported files and formats

- [Photos](#)
- [Music](#)

- [Audio sampling rates \(for videos\)](#)
- [External subtitles](#)

[35] Using the TV with Other Devices | USB devices | Supported files and formats

Audio sampling rates (for videos)

Audio Codec	Sampling Rate
MPEG-1/MPEG-2 Layer I	48 kHz, 448 kbit/s
MPEG-1/MPEG-2 Layer II	48 kHz, 384 kbit/s
MPEG-1/MPEG-2 Layer III	48 kHz, 320 kbit/s
WMA 2/3/4/5/6/7/8/9	48 kHz, 320 kbps, 5.1ch
AAC	96 kHz, 6ch
RAAC	96 kHz, 6ch
HEAAC	96 kHz, 6ch
(MPEG4) AAC	96 kHz, 6ch
AMR	8 kHz, 1ch
AC3/AC3+	MS12
AC4	MS12
EAC3	MS12
PCM	8ch, 192 kHz
PCM_S8	8ch, 192 kHz
PCM_U8	8ch, 192 kHz
LPCM	8ch, 192 kHz
PCM_S16BE	8ch, 192 kHz

Audio Codec	Sampling Rate
PCM_U16LE	8ch, 192 kHz
PCM_U16BE	8ch, 192 kHz
PCM_S16LE	8ch, 192 kHz
ADPCM	2ch, 48k
OPUS (HTML5 YouTube)	6ch
FLAC	96k, 6ch
VORBIS	192 kHz, 6ch
AMR_NB	8 kHz, 1ch
AMR_WB	16 kHz, 1ch
WAVEFORMATEX	8ch, 192 kHz
G711 A/mu-law	8ch

Other supported files and formats

- [Photos](#)
- [Music](#)
- [Videos](#)
- [External subtitles](#)

[36] Using the TV with Other Devices | USB devices | Supported files and formats

External subtitles

Use case : USB

File Format	Extension
SRT	*.srt

File Format	Extension
IdxSub	*.idx
PSB	*.psb
SMI	*.smi, *.sami
SSA	*.ssa, *.ass

Other supported files and formats

- [Photos](#)
- [Music](#)
- [Videos](#)
- [Audio sampling rates \(for videos\)](#)

[37] Using the TV with Other Devices

Blu-ray and DVD players

[Connecting a Blu-ray or DVD player](#)

[Watching Blu-ray and DVD discs](#)

[38] Using the TV with Other Devices | Blu-ray and DVD players

Connecting a Blu-ray or DVD player

Connect a Blu-ray/DVD player to the TV.

Use a connection method below based on the terminals available on your TV.

Note

- The available terminals depend on your model/region/country.

Hint

- You can also connect a set-top box (cable/satellite box) in the same way as a Blu-ray/DVD player.

HDMI connection

For optimum picture quality, we recommend connecting your player to the TV using an HDMI cable. If your Blu-ray/DVD player has an HDMI jack (socket), connect it using an HDMI cable.

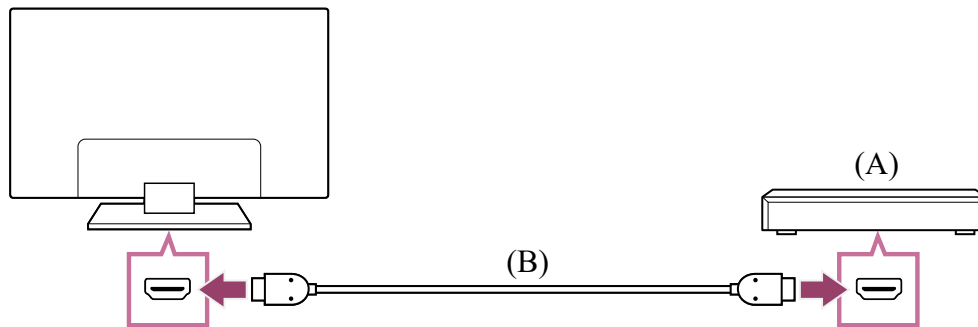

(A) Blu-ray/DVD player (same as connecting a set-top box)

(B) HDMI cable (not supplied)*

* Be sure to use an authorized HIGH SPEED HDMI cable bearing the HDMI logo.

Composite connection

If your Blu-ray/DVD player has composite jacks (sockets), connect them using a composite video/audio cable.

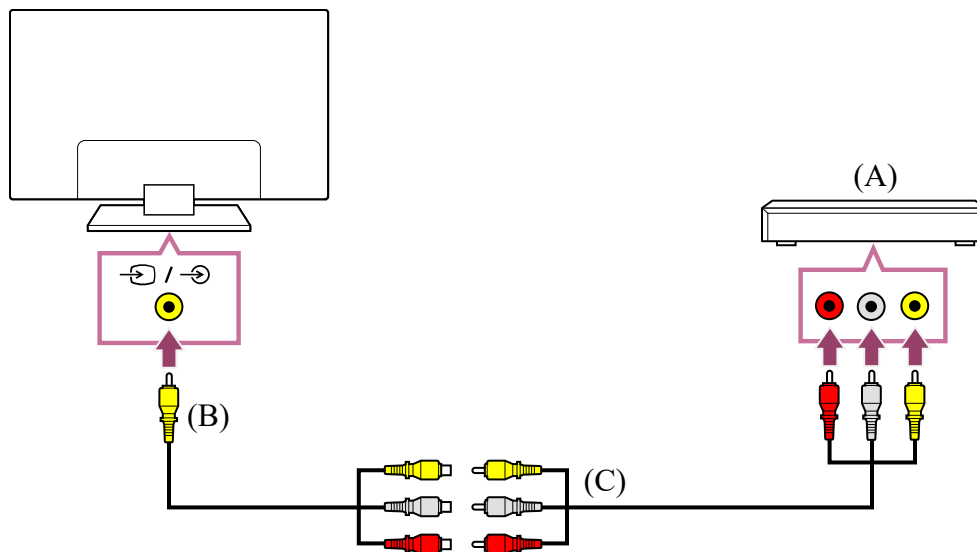

(A) Blu-ray/DVD player (same as connecting a cable/satellite box)

(B) Analog Extension cable (supplied)*

(C) RCA Cable (not supplied)

* Whether the Analog Extension cable is supplied depends on your model/region/country.

Cable that connects to the video input jack

The 3.5 mm jack of the Analog Extension Cable has 4 poles.

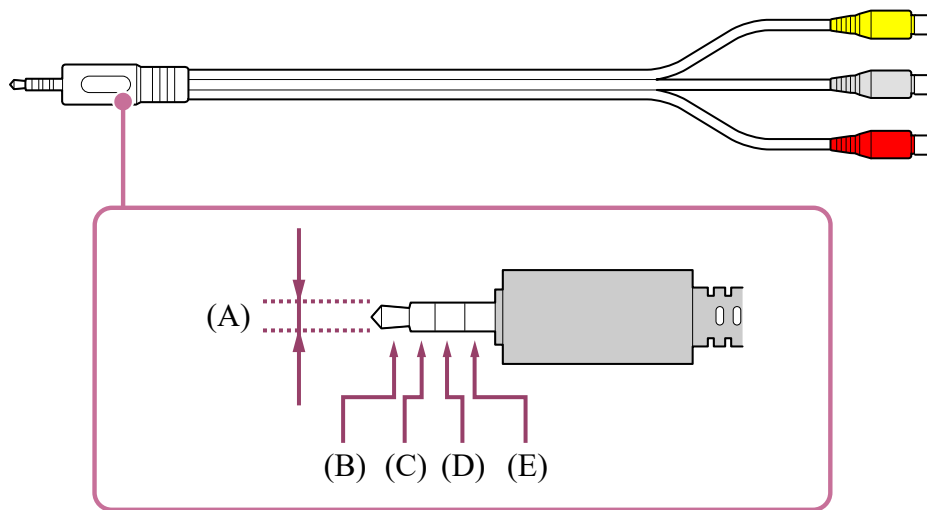

- (A) 3.5 mm
- (B) Left for Audio signal.
- (C) Video signal.
- (D) Ground.
- (E) Right for Audio signal.

Related topics

- [Watching Blu-ray and DVD discs](#)

[39] Using the TV with Other Devices | Blu-ray and DVD players

Watching Blu-ray and DVD discs

You can watch content from Blu-ray/DVD discs or other content supported by your player on the TV.

- 1 **Turn on the connected Blu-ray/DVD player.**
- 2 **Press the  (Input) button repeatedly to select the connected Blu-ray/DVD player.**
- 3 **Start playback on the connected Blu-ray/DVD player.**

Hint

- If you connect a CEC-compatible device with an HDMI connection, you can operate it by simply using the TV's remote control.

Related topics

- [Connecting a Blu-ray or DVD player](#)
- [CEC-compatible devices](#)

[40] Using the TV with Other Devices

Set-top box (cable/satellite box)

[Connecting a Set-top box \(cable/satellite box\)](#)

[41] Using the TV with Other Devices | Set-top box (cable/satellite box)

Connecting a Set-top box (cable/satellite box)

Connect the set-top box (cable/satellite box) to the TV as you would a Blu-ray or DVD player.

For details, refer to the [Connecting a Blu-ray or DVD player](#) page.

[42] Using the TV with Other Devices

Enjoying content from your mobile device on the TV with Google Cast

Google Cast allows you to wirelessly cast content from your favorite websites and apps to your TV, directly from your computer or mobile device.

- 1 Connect a mobile device such as a smartphone or tablet to the same network that the TV is connected to.**
- 2 Launch a Google Cast supported app on the mobile device.**
- 3 Select the  (cast) icon in the app.**

The screen of the mobile device is displayed on the TV.

Note

- An Internet connection is required to use Google Cast.

Related topics





- [Connecting to a network using a LAN cable](#)
- [Using Wi-Fi to connect the TV to the Internet/Network](#)

[43] Using the TV with Other Devices



Displaying the iPhone/smartphone or iPad/tablet app screen on the TV

Using AirPlay

This TV supports AirPlay 2.

- 1 Make sure your Apple device is connected to the same network as your TV.**
- 2 The procedure depends on the content that will be displayed on the TV as follows.**
 - To display video, tap  (AirPlay Video).
 - To display photos, tap  (Action share).
 - To play music, tap  (AirPlay Audio).
 - To display the screen of a mobile device, tap  (Mirroring).
(In some apps, you may have to tap another icon first.)
- 3 Select AirPlay on a mobile device such as an iPhone or iPad, and select the TV to use with AirPlay.**

Hint

- The TV supports Apple HomeKit.
You can control the TV with a mobile device such as an iPhone or iPad by pressing the  (Input) button on the remote control, selecting  (AirPlay), and following

the on-screen instructions to setup Apple HomeKit.

Available operations vary depending on the version of the app and software.

- If you select [On (Powered on by apps)] in [Remote start], you can turn on the TV with apps on a mobile device such as an iPhone or iPad.

Note

- An internet connection is required to use AirPlay.
- Operation of a mobile device such as iPhone or iPad varies depending on the OS version.
- iPhone, iPad, AirPlay and HomeKit are trademarks of Apple Inc., registered in the U.S. and other countries.

Related topics

- [Connecting to a network using a LAN cable](#)
- [Using Wi-Fi to connect the TV to the Internet/Network](#)

[44] Using the TV with Other Devices

Computers, cameras, and camcorders

[Connecting a computer and viewing stored content](#)

[Connecting a camera or camcorder and viewing stored content](#)

[Computer video signal specifications](#)

[45] Using the TV with Other Devices | Computers, cameras, and camcorders

Connecting a computer and viewing stored content

To connect a computer

Use an HDMI cable to connect your computer to the TV.

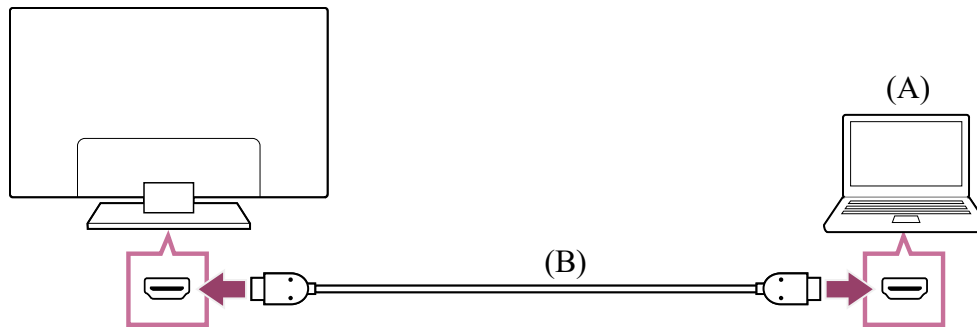

(A) Computer

(B) HDMI cable (not supplied)*

* Be sure to use an authorized HIGH SPEED HDMI cable bearing the HDMI logo.

To check the video signal specifications

- [Computer video signal specifications](#)

To view content stored on a computer

After connecting the computer, press the  (Input) button, then select the input the computer is connected to.

To check the supported file formats

- [Supported files and formats](#)

Note

- For optimum picture quality, we recommend that you set your computer to output video signals according to one of the settings listed in “Computer video signal specifications”.
- Depending on the connection status, the image may be blurred or smeared. In this case, change the computer’s settings and select another input signal from the “Computer video signal specifications” list.

[46] Using the TV with Other Devices | Computers, cameras, and camcorders

Connecting a camera or camcorder and viewing stored content

To connect a camera or camcorder

Connect your Sony digital still camera or camcorder using an HDMI cable. Use a cable that has an HDMI mini jack (socket) for the digital still camera/camcorder end, and a standard HDMI jack (socket) for the TV end.

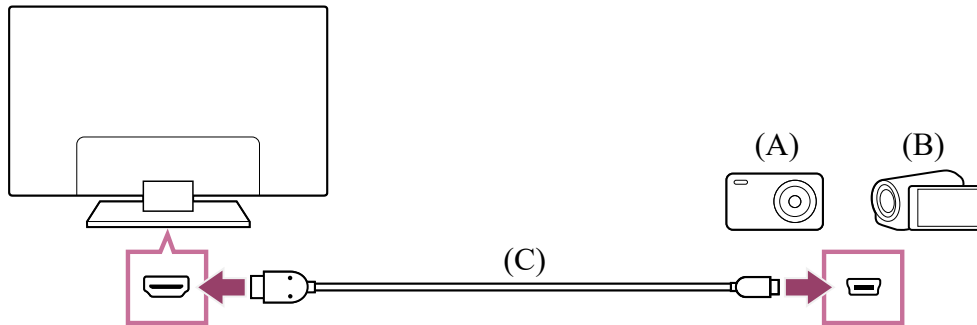

- (A) Digital still camera
(B) Camcorder
(C) HDMI cable (not supplied)*

* Be sure to use an authorized HIGH SPEED HDMI cable bearing the HDMI logo.

To view content stored on a digital still camera/camcorder

- 1 After connecting the digital still camera/camcorder, turn it on.
- 2 Press the  (Input) button repeatedly to select the connected digital still camera/camcorder.
- 3 Start playback on the connected digital still camera/camcorder.

To check the supported file formats

- [Supported files and formats](#)

Hint

- If you connect a CEC-compatible device, you can operate it by simply using the TV's remote control. Make sure that the device is CEC-compatible. Some devices may not be compatible with CEC even though they have an HDMI jack (socket).

Related topics

- [CEC-compatible devices](#)

[47] Using the TV with Other Devices | Computers, cameras, and camcorders

Computer video signal specifications

(Resolution, Horizontal frequency/Vertical frequency)

- 640 x 480, 31.5 kHz/60 Hz
- 800 x 600, 37.9 kHz/60 Hz
- 1024 x 768, 48.4 kHz/60 Hz
- 1152 x 864, 67.5 kHz/75 Hz
- 1280 x 1024, 64.0 kHz/60 Hz
- 1600 x 900, 55.9 kHz/60 Hz
- 1680 x 1050, 65.3 kHz/60 Hz
- 1920 x 1080, 67.5 kHz/60 Hz*

* 1080p timing, when applied to the HDMI input, will be treated as video timing and not computer timing. This will affect the [Screen] settings in [Settings] — [Display & Sound]. To view computer content, set [Wide mode] to [Full pixel].

Other video input signals

The following video formats can be displayed depending on specifications of your computer.

- 480p, 480i
- 576p*, 576i*
- 720/24p
- 720p/30 Hz, 720p/50 Hz*, 720p/60 Hz
- 1080i/50 Hz*, 1080i/60 Hz
- 1080/24p
- 1080p/30 Hz, 1080p/50 Hz*, 1080p/60 Hz
- 3840 x 2160p/24 Hz, 3840 x 2160p/25 Hz*, 3840 x 2160p/30 Hz (4K models only)
- 3840 x 2160p/50 Hz* (4K models only)
- 4096 x 2160p/50 Hz* (4K models only)

* Not supported depending on your region/country.

Note

- 1920 x 1080/60 Hz output may not be available, depending on your computer. Even if 1920 x 1080/60 Hz output is selected, the actual output signal may differ. In this case, change the computer's settings, then set your computer to use a different video signal.

[48] Using the TV with Other Devices

Audio system

[Outputting audio from an audio system](#)

[Connecting an audio system](#)

[Adjusting an audio system](#)

[Pass-through audio formats supported with eARC \(only models equipped with an HDMI IN \(eARC/ARC\) terminal\)](#)

[49] Using the TV with Other Devices | Audio system

Outputting audio from an audio system

You can connect audio systems such as AV receivers or sound bars to the TV. Select a connection method below according to the specifications of the audio system you want to connect.

- Connecting with an HDMI cable (For details, carefully read “Connection using an HDMI cable” below.)
- Connecting with a digital optical cable

For connection methods, refer to the [Connecting an audio system](#) page.

Note

- Refer to the instruction manual of the device to be connected.

Connection using an HDMI cable

This TV supports Audio Return Channel (ARC) or Enhanced Audio Return Channel (eARC). You can use an HDMI cable to output audio from audio systems that support ARC and eARC.

On TVs that support eARC (only models equipped with an HDMI IN (eARC/ARC) terminal), you can output (pass-through) audio signals from external input devices connected to the TV to eARC supported audio systems by using the HDMI terminal bearing the text “eARC/ARC”.

For connection methods, refer to the [Connecting an audio system](#) page.

Note

- The availability and location of the HDMI terminal that supports eARC/ARC varies depending on the model. Refer to the included Setup Guide.

Related topics

- [Pass-through audio formats supported with eARC \(only models equipped with an HDMI IN \(eARC/ARC\) terminal\)](#)

[50] Using the TV with Other Devices | Audio system

Connecting an audio system

See the illustrations below to connect an audio system such as an AV receiver or sound bar.

Note

- The available terminals depend on your model/region/country.

HDMI connection (ARC supported)

1 Connect the TV and audio system with an HDMI cable.

Connect to the TV's HDMI input terminal bearing the text “ARC” or “eARC/ARC”.

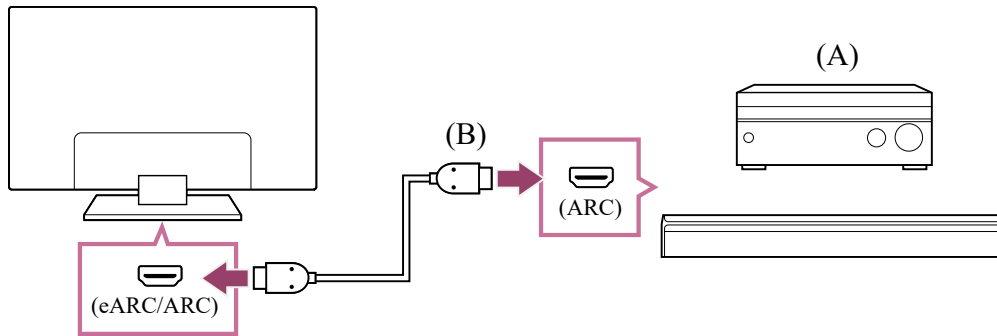

- (A) AV receiver or sound bar
 (B) HDMI cable (not supplied)*

* We recommend authorized Premium High Speed HDMI™ Cable(s) bearing the HDMI logo.

2 Adjusting an audio system

HDMI connection (eARC supported) (only models equipped with an HDMI IN (eARC/ARC) terminal)

- 1 **Connect the external input device and TV with an HDMI cable. Connect the TV and audio system with another HDMI cable.**

Connect the audio system to the TV's HDMI input terminal bearing the text "ARC" or "eARC/ARC".

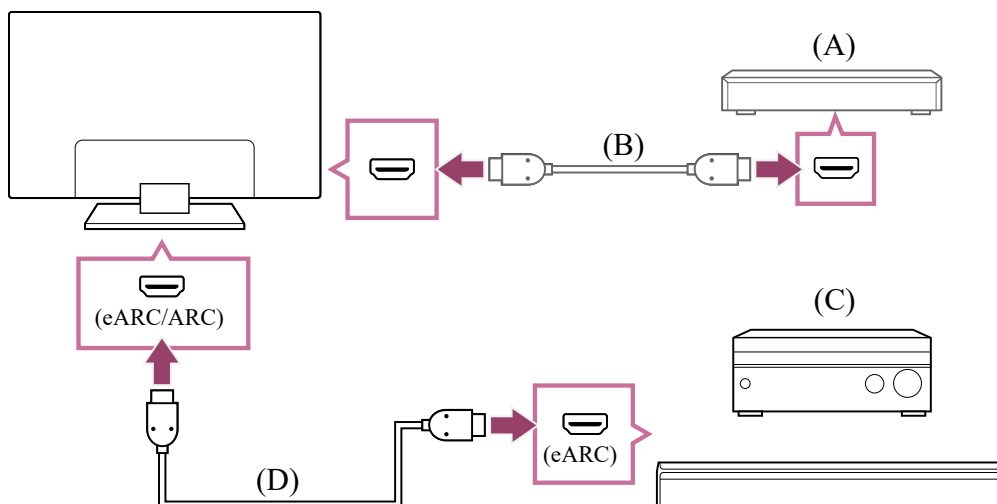

- (A) External input device (such as a Blu-ray/DVD recorder)
 (B) HDMI cable (not supplied)
 (C) AV receiver or sound bar
 (D) HDMI cable with Ethernet (not supplied)*

* We recommend authorized Premium High Speed HDMI™ Cable(s) bearing the HDMI logo.

- 2 Press the  (Quick Settings) button on the remote control, then select [Settings] — [Display & Sound] — [Audio output] — [Speakers] — [Audio system].
- 3 Adjusting an audio system

Digital optical cable connection

- 1 **Connect the TV and audio system with a digital optical cable.**
Connect to the audio system's digital optical input terminal.

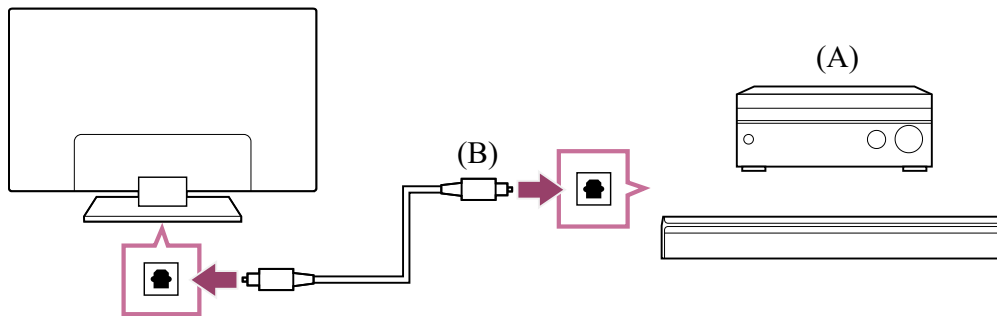

- (A) AV receiver or sound bar
(B) Optical audio cable (not supplied)

- 2 Adjusting an audio system

Hint

- For more information, please visit the Sony support website.
[Support Site](#)

Related topics

- [No sound but good picture.](#)
- [No audio or low audio with a home theater system.](#)

Adjusting an audio system

After connecting an audio system to the TV, adjust the TV's audio output from the audio system.

Adjusting an audio system connected with an HDMI cable or digital optical cable

- 1 After connecting the TV to your audio system, press the  (Quick Settings) button on the remote control, then select [Settings] — [Display & Sound] — [Audio output] — [Speakers] — [Audio system].

- 2 Turn on the connected audio system, then adjust the volume.

If you connect a CEC-compatible device with an HDMI connection, you can operate it by simply using the TV's remote control.

Note

- You need to configure the [Digital Audio Out] settings according to your audio system. Press the  (Quick Settings) button on the remote control, then select [Settings] — [Display & Sound] — [Audio output] — [Digital Audio Out].
- If the audio system is not compatible with Dolby Digital, set [Settings] — [Display & Sound] — [Audio output] — [Digital Audio Out] to [PCM].

Related topics

- [CEC-compatible devices](#)
- [Connecting an audio system](#)
- [No sound but good picture.](#)
- [No audio or low audio with a home theater system.](#)

[52] Using the TV with Other Devices | Audio system

Pass-through audio formats supported with eARC (only models equipped with an HDMI IN (eARC/ARC) terminal)

Confirm that you can pass-through the following audio formats.

- 7.1 channel linear PCM: 32/44.1/48 kHz 16 bits
- Dolby Digital
- Dolby Digital Plus
- Dolby TrueHD
- Dolby Atmos

For details, refer to the support page.

- [Support Site](#)

Related topics

- [Connecting an audio system](#)

[53] Using the TV with Other Devices

Bluetooth devices

[Connecting a Bluetooth device](#)

[Supported Bluetooth profiles](#)

[54] Using the TV with Other Devices | Bluetooth devices

Connecting a Bluetooth device

To pair the TV with a Bluetooth device

- 1 Turn the Bluetooth device on and put it in pairing mode.**
To put your Bluetooth device in pairing mode, refer to the instruction manual of the device.
- 2 Press the  (Quick Settings) button on the remote control, then select [Settings] — [Remotes & Accessories] — [Pair accessory] to put the TV in pairing mode.**
A list of available Bluetooth devices will be displayed.

- 3 **Select the desired device from the list, then follow the on-screen instructions.**

If you are prompted to enter a passcode, refer to the instruction manual of the device.

After pairing is completed, the device connects to the TV.

To connect to a paired Bluetooth device

- 1 **Press the  (Quick Settings) button on the remote control, then select [Settings] — [Remotes & Accessories].**
- 2 **Select a paired but unconnected device from the list.**
- 3 **Select [Connect].**

Related topics

- [Supported Bluetooth profiles](#)
- [Operation cuts out, or a device does not work.](#)
- [You want to output sound from the headphones/Bluetooth audio device and audio system/TV speakers at the same time.](#)

[55] Using the TV with Other Devices | Bluetooth devices

Supported Bluetooth profiles

The TV supports the following profiles:

- HID (Human Interface Device Profile)
- HOGP (HID over GATT Profile)
- A2DP (Advanced Audio Distribution Profile)
- AVRCP (Audio/Video Remote Control Profile)
- SPP (Serial Port Profile)

Related topics

- [Connecting a Bluetooth device](#)

[56] Using the TV with Other Devices

CEC-compatible devices

[CEC overview](#)

[Using features available for CEC-compatible devices](#)

[Adjusting HDMI CEC settings](#)

[57] Using the TV with Other Devices | CEC-compatible devices

CEC overview

If a CEC-compatible device (e.g., Blu-ray player, AV receiver) is connected with an HDMI cable, you can operate the device with the TV's remote control.

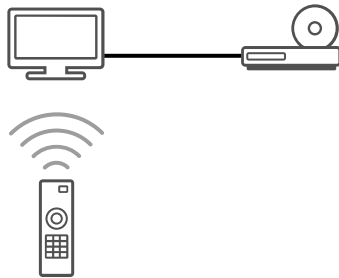

Related topics

- [Using features available for CEC-compatible devices](#)
 - [Adjusting HDMI CEC settings](#)
-

[58] Using the TV with Other Devices | CEC-compatible devices

Using features available for CEC-compatible devices

Blu-ray/DVD player

- Automatically turns the Blu-ray/DVD player on and switches the input to the Blu-ray/DVD player when you select it from the input source.
- Automatically turns the TV on and switches the input to the connected Blu-ray/DVD player when the Blu-ray/DVD player starts to play.
- Automatically turns the connected Blu-ray/DVD player off when you turn the TV off.
- Controls menu operation (▲ (Up) / ▼ (Down) / ◀ (Left) / ▶ (Right) buttons), playback (e.g., ▶|| (Play / Pause) button), and channel selection of the connected Blu-ray/DVD player through the TV's remote control.

AV receiver

- Automatically turns the connected AV receiver on and switches the sound output from the TV speaker to the audio system when you turn the TV on. This function is only available if you have previously used the AV receiver to output the TV's sound.
- Automatically switches the sound output to the AV receiver by turning the AV receiver on when the TV is turned on.
- Automatically turns the connected AV receiver off when you turn the TV off.
- Adjusts the volume (◀ (Volume) +/- buttons) and mutes the sound (⊘ (Mute) button) of the connected AV receiver through the TV's remote control.

Video camera

- Automatically turns the TV on and switches the input to the connected video camera when the camera is turned on.
- Automatically turns the connected video camera off when you turn the TV off.
- Controls menu operation (▲ (Up) / ▼ (Down) / ◀ (Left) / ▶ (Right) buttons), playback (e.g., ▶|| (Play / Pause) button) of the connected video camera through the TV's remote control.

Note

- "CEC" is only available for connected CEC-compatible devices.
- Behavior of the CEC devices may vary.

Related topics

- [CEC overview](#)

- [Adjusting HDMI CEC settings](#)

[59] Using the TV with Other Devices | CEC-compatible devices

Adjusting HDMI CEC settings

- 1 **Turn on the connected device.**
- 2 **To enable [HDMI CEC Settings], press the  (Quick Settings) button on the remote control, then select [Settings] — [Channels & Inputs] — [External inputs] — [HDMI CEC Settings] — [CEC].**
- 3 **Activate HDMI CEC Settings on the connected device.**
When a specific Sony CEC-compatible device is connected and powered on and [HDMI CEC Settings] is enabled, HDMI CEC Settings is automatically activated on that device. For details, refer to the instruction manual of the connected device.

Available options

Available options are shown below. (Options vary depending on your model/region/country.)

[Device auto power off]

If disabled, the connected device does not turn off automatically when the TV is turned off.

[TV auto power on]

If disabled, the TV does not turn on automatically when the connected device is turned on.

Related topics

- [CEC overview](#)
- [Using features available for CEC-compatible devices](#)

[60] Using the TV with Other Devices

Viewing pictures in 4K from compatible devices

[Viewing pictures in 4K resolution](#)

[Settings for viewing pictures in 4K resolution with higher quality](#)

[61] Using the TV with Other Devices | Viewing pictures in 4K from compatible devices

Viewing pictures in 4K resolution

A picture with a 4K or higher resolution can be displayed in 4K resolution (3840×2160).

You can connect a digital still camera/camcorder that supports HDMI 4K output to HDMI IN of the TV to display high resolution photos stored on the camera. You can also display high resolution photos stored in connected USB devices.

The availability of this function depends on your region/country.

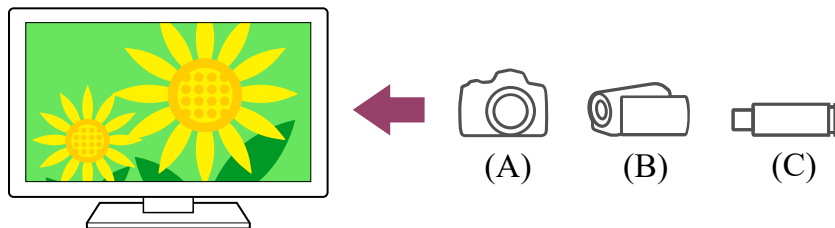

(A) Digital still camera

(B) Camcorder

(C) USB device

To view pictures stored on a USB device in 4K resolution

- 1 **Connect the USB device to the TV.**
- 2 **Press the  (Home) button, select Apps from the Home menu, and select [Media Player] — [Album] — the USB device — the folder and/or file from the list.**

To view pictures stored on a digital still camera/camcorder

- 1 **Connect a digital still camera or camcorder that supports HDMI output to the HDMI IN jack (socket) of the TV, using an HDMI cable.**
- 2 **Press the  (Input) button repeatedly to select the connected device.**

- 3 **Set the connected device to 4K output.**
- 4 **Start playback on the connected device.**

To check the supported file formats

- [Supported files and formats](#)

To view pictures in 4K resolution with higher quality

You can set the HDMI signal format to [Enhanced format]/[Enhanced format (ALLM)] to view pictures in 4K resolution with higher quality.

For information about Enhanced format or changing the settings, refer to the [Settings for viewing pictures in 4K resolution with higher quality](#) page.

Note

- A 3D picture cannot be displayed.
- If you change the picture by pressing the ◀ (Left) / ▶ (Right) buttons, it may take time to display.

Related topics

- [Computers, cameras, and camcorders](#)
- [USB devices](#)
- [Connecting to a Network](#)

[62] Using the TV with Other Devices | Viewing pictures in 4K from compatible devices

Settings for viewing pictures in 4K resolution with higher quality

When you display the High-Quality 4K format with the HDMI input, set [HDMI signal format] in [External inputs].

[HDMI signal format]

To change the HDMI signal format setting, press the  (Quick Settings) button on the remote control, then select [Settings] — [Channels & Inputs] — [External inputs] — [HDMI

signal format] — the HDMI input you want to set.

[Standard format]

Standard HDMI format^{*1} that prioritizes compatibility with connected device.

[Enhanced format]/[Enhanced format (ALLM)]

High-Quality HDMI format^{*1*2} that prioritizes image quality when watching content from 4K supported devices.

Supports Auto Low Latency Mode (ALLM) when connecting to game consoles^{*3}.

Applicable to HDMI IN 3.

^{*1} HDR included (HDR models only).

^{*2} 4K 60p 4:2:0 10 bit, 4:4:4, 4:2:2 etc.

^{*3} Support depends on your model.

Note

- When using [Enhanced format]/[Enhanced format (ALLM)], picture and sound may not be output correctly. In this case, connect the device to an HDMI IN that is in [Standard format], or change the HDMI signal format of HDMI IN to [Standard format].
- Set to [Enhanced format]/[Enhanced format (ALLM)] only when using compatible devices.
- When you watch 4K picture with High-Quality, use a Premium High Speed HDMI™ Cable(s) that supports speeds of 18 Gbps. For details on a Premium High Speed HDMI™ Cable(s) that supports 18 Gbps, refer to the cable specifications.

Related topics

- [Viewing pictures in 4K resolution](#)

[63]

Connecting to a Network

[Connecting to a network using a LAN cable](#)

[Connecting to a network using a wireless connection](#)

[64] Connecting to a Network

Connecting to a network using a LAN cable

Connecting to a network using a LAN cable

A wired LAN connection allows you to access the Internet.

Make sure to connect to the Internet via a router.

Hint

- If you are using a modem with router functions, you do not need to prepare a separate router. Ask your service provider for information about your modem's specifications.

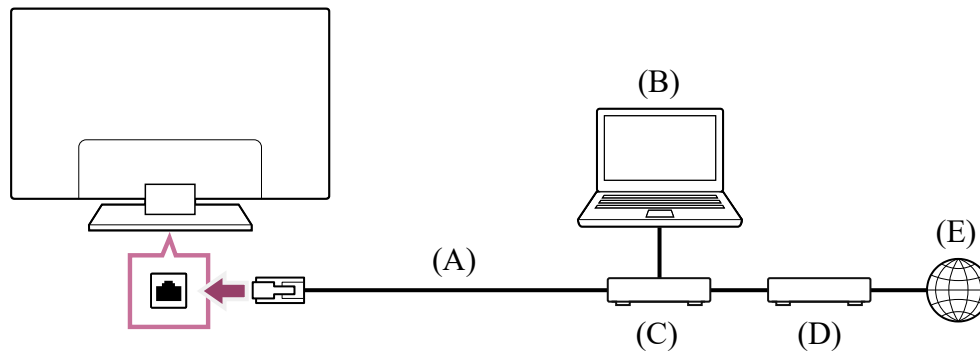

(A) LAN cable

(B) Computer

(C) Router

(D) Modem

(E) Internet

1 Set up your LAN router.

For details, refer to the instruction manual of your LAN router, or contact the person who set up the network (network administrator).

2 Once a LAN cable is connected, the TV will automatically connect to the network.

You can check your status in [Settings] — [Network & Internet] — [Network status] — [Check Connection].

Note

- It is strongly recommended for security purposes to connect your TV to the Internet via a router/modem that includes router functionality. Direct connection of your TV to the Internet may expose your TV to a security threat such as extraction or tampering of content or personal information.

Contact your service provider or network administrator to confirm your network includes router functionality.

- The network-related settings that are required may vary depending on the Internet service provider or router. For details, refer to the instruction manuals provided by the Internet service provider or those supplied with the router. You can also contact the person who set up the network (network administrator).

Related topics

- [The TV cannot connect to the Internet/Network.](#)
- [Using Wi-Fi to connect the TV to the Internet/Network](#)

[65] Connecting to a Network

Connecting to a network using a wireless connection

[Using Wi-Fi to connect the TV to the Internet/Network](#)

[66] Connecting to a Network | Connecting to a network using a wireless connection

Using Wi-Fi to connect the TV to the Internet/Network

The built-in wireless LAN device allows you to access the Internet and enjoy the benefits of networking in a cable-free environment.

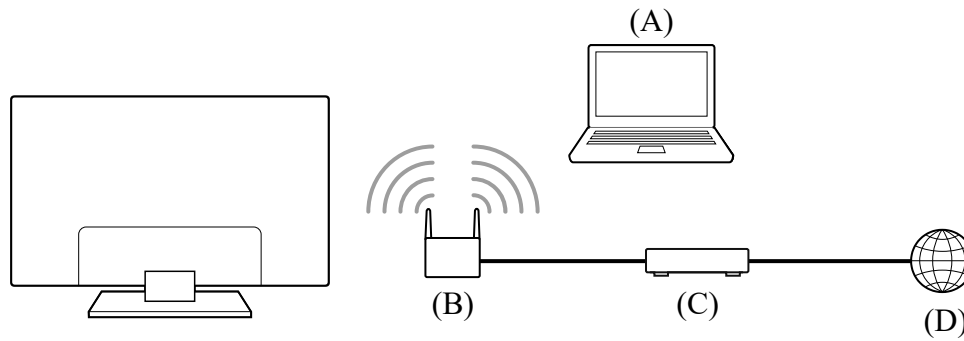

- (A) Computer
- (B) Wireless router
- (C) Modem
- (D) Internet

1 Set up your wireless router.

For details, refer to the instruction manual of your wireless router, or contact the person who set up the network (network administrator).

2 Press the  (Quick Settings) button on the remote control, then select [Settings] — [Network & Internet].

3 Select a network you want to connect and set a password.

If your TV can not connect to the Internet/Network, refer to the [The TV cannot connect to the Internet/Network.](#) page.

To turn off the built-in wireless LAN

1 To disable [Wi-Fi], press the  (Quick Settings) button on the remote control, then select [Settings] — [Network & Internet] — [Wi-Fi].

Hint

- For smooth video streaming:
 - Change the setting of your wireless router to a high-speed networking standard such as 802.11n if possible.
For details on how to change the setting, refer to the instruction manual of your wireless router, or contact the person who set up the network (network administrator).
 - If the above procedure does not deliver any improvement, change the setting of your wireless router to 5 GHz, which may help improve the video streaming quality.

- The 5 GHz band may not be supported depending on your region/country. If the 5 GHz band is not supported, the TV can only connect to a wireless router using the 2.4 GHz band.

Note

- The network-related settings that are required may vary depending on the Internet service provider or router. For details, refer to the instruction manuals provided by the Internet service provider or those supplied with the router. You can also contact the person who set up the network (network administrator).
- If you select the [Hide password] option in the password entry screen, the password can be hidden from being viewed by other individuals.

Related topics

- [Network \(Internet\)/apps](#)
- [The TV cannot connect to the Internet/Network.](#)
- [Connecting to a network using a LAN cable](#)

[67]

Configuring the TV

[[Settings](#)]

[68] Configuring the TV

[[Settings](#)]

The menus displayed in the TV settings vary depending on your model/region/country.

[[Channels & Inputs](#)]

[[Display & Sound](#)]

[[Network & Internet](#)]

[[Accounts & sign-in](#)]

[[Privacy](#)]

[[Apps](#)]

[[System](#)]

[\[Remotes & Accessories\]](#)

[\[Help & Feedback\]](#)

[69] Configuring the TV | [\[Settings\]](#)

[Channels & Inputs]

- 1 Press the  (Quick Settings) button on the remote control, then select [\[Settings\]](#) — [\[Channels & Inputs\]](#) — the desired option.

Available options

[Channels]

Configures the settings related to receiving broadcast programming.

To tune channels

Press the  (Quick Settings) button on the remote control, then select [\[Settings\]](#) — [\[Channels & Inputs\]](#) — [\[Channels\]](#) — [\[Channel Setup\]](#) — [\[Digital/Analog\]](#) — [\[Digital auto tuning/Analog auto tuning\]](#).

[Preferences (Channels)]

Configures [\[Shown channels\]](#), [\[Captions\]](#) and [\[Preferred language\]](#).

[Info banner]

Display program information when channel is changed.

[External inputs]

Configures the settings of the external inputs.

[Manage inputs]

Choose to show or hide inputs, and label the inputs according to their connected devices.

[HDMI CEC Settings]

Set up CEC compatible devices for streamlined control.

For details, refer to the [Adjusting HDMI CEC settings](#) page.

[TV button shortcut]

Select what will launch when the TV button is pressed.

[HDMI signal format]

Enhance 4K HDMI signal format.

For details, refer to the [Settings for viewing pictures in 4K resolution with higher quality](#) page.

[70] Configuring the TV | [Settings]

[Display & Sound]

- 1 Press the  (Quick Settings) button on the remote control, then select [Settings] — [Display & Sound] — the desired option.

Available options

[Picture adjustments]

Adjust the picture settings such as Brightness, Color, and Hue.

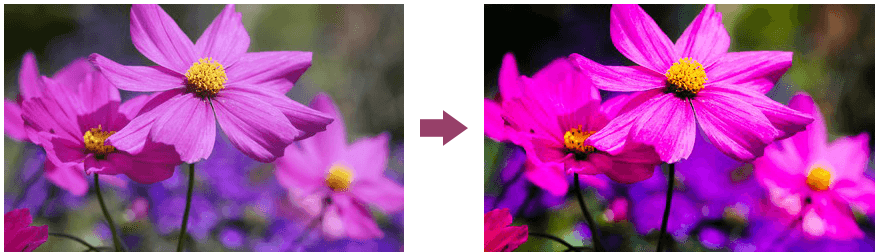

[Picture mode]

Change the picture quality according to the content you are watching such as movies or sports. For more details, refer to the [“Picture adjustments” advanced settings](#) page.

[Auto picture mode]

Automatically sets the picture mode based on the content from HDMI devices.

[Brightness]

Adjust the backlight to display the brightest whites and deepest blacks.

[Color]

Adjust the color saturation level.

[Advanced]

Access advanced picture enhancing options.

For more details, refer to the [“Picture adjustments” advanced settings](#) page.

Hint

- You can also display [Picture adjustments] by pressing the  (Quick Settings) button while watching TV, then selecting [Picture settings].

[Screen]

Adjust the aspect ratio and viewable screen area.

[Wide mode]

Adjust the picture size.

[4:3 default]

Automatic sizing for 4:3 pictures.

[Sound adjustments]

You can configure various settings related to the TV's sound such as sound quality and sound mode.

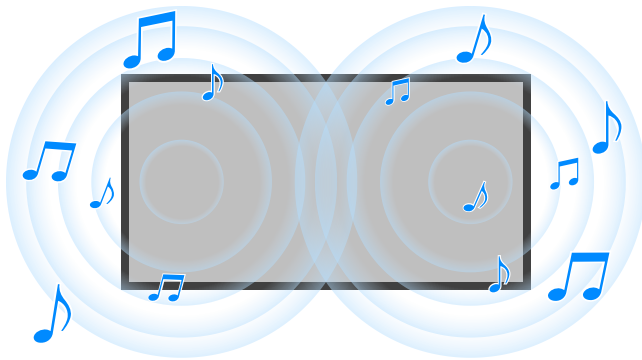

[Dialog enhancer]

Emphasizes voice.

[Surround]

Virtually reproduces realistic surround sound.

[Equalizer]

Adjust sound based on different frequencies.

Available only when [Speakers] is set to [TV speakers] and a headphone is not connected to the TV.

[TV position]

Outputs sound from the TV speakers according to the position of the TV.

[Advanced]

Access advanced sound enhancing options.

For details, refer to the [“Sound adjustments” advanced settings](#) page.

Hint

- You can also display [Sound adjustments] by pressing the  (Quick Settings) button while watching TV, then selecting [Sound settings].

[Audio output]

Adjust for audio system.

[Speakers]

Selects TV speakers or Audio system.

[Digital Audio Out]

Configure the output method when outputting digital audio. This setting is not available when [Speakers] is set to [TV speakers].

[71] Configuring the TV | [Settings] | [Display & Sound]

“Picture adjustments” advanced settings

This page introduces various settings for the features you can configure in [Picture mode] and [Advanced].

Note

- The actual display may vary or some settings may not be available depending on your model/country/region and the content you are watching.

[Picture mode]

Setting	Description
Vivid	Picture with enhanced edges and contrast.
Standard	Suitable picture for basic home use.
Cinema	Suitable picture for watching movies.
Game	Suitable picture for playing video games.
Graphics	Suitable picture for watching tables and characters.
Photo	Suitable picture for photo viewing.

Setting	Description
Custom	Customize picture settings.

[Advanced]

[Brightness] settings

Setting	Description
Brightness	Adjust the luminance level of the screen.
Contrast	Adjust the picture white level.
Gamma	Adjust the light and dark balance. Brighten or darken the brightness between white and black.
Black level	Adjust the picture black level.
Black adjust	Enhance the black in images for stronger contrast.
Adv. contrast enhancer	Automatically adjusts the contrast based on picture brightness.

[Color] settings

Setting	Description
Color	Adjust the color saturation level.
Hue	Adjust the green and red tones.
Color temperature	Adjust the color temperature.
Adv. color temperature	Adjust the color temperature in detail.
Live Color	Improve the vividness of colors.

[Clarity] settings

Setting	Description
Sharpness	Adjust the picture detail.
Reality Creation	Adjusts fineness and noise for realistic picture. If you select [Manual], you can adjust [Resolution].
Random noise reduction	Reduce repetitive random noise.
Digital noise reduction	Reduce video compression noise.

[Motion] settings

Setting	Description
Motionflow	Refines moving images. Increases the number of image frames to display videos smoothly. If you select [Custom], you can manually adjust [Smoothness] and [Clearness]. (For [Motionflow] compatible models only)
CineMotion	Optimizes picture quality based on video content, such as movies and computer graphics. Smoothly reproduces the motion of filmed images (images recorded at 24 frames per second) such as movies.

[Video options] settings

Setting	Description
HDMI video range	Select the signal range for HDMI input.

[Reset] settings

Setting	Description
Reset	Return all advanced picture settings to factory default.

Related topics

- [\[Picture adjustments\]](#)

[72] Configuring the TV | [Settings] | [Display & Sound]

“Sound adjustments” advanced settings

This page introduces various settings for the features you can configure in [Sound adjustments] — [Advanced].

Note

- The actual display may vary or some settings may not be available depending on your model/country/region and the connected device.

[Advanced]

Setting	Description
Common	Adjust [Balance] and [Digital audio out volume]*. * Applied for PCM only. The volume levels between PCM and compressed audio will differ.
Input related	Adjust [Volume offset] and [Dynamic range].
Reset	Return all sound settings to factory default.

Related topics

- [\[Sound adjustments\]](#)

[73] Configuring the TV | [Settings]

[Network & Internet]

Configures settings such as for wireless LANs and wired LANs.

For more information, refer to the [The TV cannot connect to the Internet/Network](#) page.

Related functions

[Remote start]

Allows an external device to turn on the TV. This may increase power consumption more than the normal configuration.

[IP control]

Enables other devices to communicate with the TV.

[Control remotely] lets registered remote devices control this TV, [Authentication] selects the authentication method to allow other device to communicate with the TV (None/Pre-Shared Key), [Pre-Shared Key] allows you to set a secret string for accessing the TV's IP control.

[74] Configuring the TV | [Settings]

[Accounts & sign-in]

- 1 Press the  (Quick Settings) button on the remote control, then select [Settings] — [Accounts & sign-in] — the desired option.

Available options

When a Google Account is set on the TV

Configure the Google Account or add other accounts.

When a Google Account is not set on the TV

[Accounts & sign-in] cannot be used. To set a Google Account, set up Google TV from the settings menu.

[75] Configuring the TV | [Settings]

[Privacy]

You can restrict the installation of apps from unknown sources.

[76] Configuring the TV | [Settings]

[Apps]

Allows you to configure or delete apps.

[77] Configuring the TV | [Settings]

[System]

- 1 Press the  (Quick Settings) button on the remote control, then select [Settings] — [System] — the desired option.

Note

- Depending on the settings of the TV, some options may not be displayed or available.

Available options

[Accessibility]

Configures the settings of accessibility features and services for helping users navigate their devices more easily.

You can turn on captions for streaming apps here (for supported apps only), and customize the appearance of captions (limited to captions of certain TV features only).

[About]

Displays information about the TV.

[Date & Time]

Adjusts the current time.

[Language]

Selects the menu language. The selected menu language will also set the voice recognition language.

[Keyboard]

Configures the settings of the on-screen keyboard.

[Storage]

Changes the settings related to data storage.

[Ambient mode]

Configures what is displayed on the screen when the TV is not operated after a certain amount of time while displaying content other than broadcasts and videos.

[Power and Energy]

Changes the settings related to power consumption.

[Power saving] reduces power consumption of the TV by adjusting the backlight, [Idle TV power off] turns the TV off after it has been kept idle for the preset length of time, [Auto shut-off] turns off the TV automatically if no signal is detected for 15 minutes.

[Cast]

Configures the operation permissions when casting from an external device.

[System sounds]

Configures the [System sounds] setting.

[Parental controls]

Configures the parental control settings.

[Off] / [On]

Disables [Off] or enables [On] parental control on the TV.

[External input block]

Blocks inputs from being watched.

[Channels blocked]

Blocks channels from being watched.

[Program restrictions]

Blocks programs based on the rating of your selected country (available for certain countries only).

[Change PIN]

Change PIN code for access to parental controls settings.

[Restart]

Restart the TV without changing the user settings.

[Apple AirPlay and HomeKit]

Configures the settings for Apple AirPlay and HomeKit.

[Retail mode settings]

Enriches the display for shop front use by setting [Demo mode], etc.

[78] Configuring the TV | [Settings]

[Remotes & Accessories]

- 1 Press the  (Quick Settings) button on the remote control, then select [Settings] — [Remotes & Accessories] — the desired option.

Available options

You can enable or disable Bluetooth, or register Bluetooth devices.

[Bluetooth]

Enables or disables Bluetooth.

[Pair accessory]

Pairs Bluetooth devices.

For details, refer to the [Supported Bluetooth profiles](#) page.

[Remote control]

Setup for pairing the Voice Remote Control.

Related topics

- [Bluetooth devices](#)
 - [Using the remote control microphone](#)
-

[79] Configuring the TV | [Settings]

[Help & Feedback]

Help from Sony can be displayed here. If a Google Account is set on the TV, you can also give Google feedback.

[80]

Troubleshooting

[Start here](#) [Experiencing trouble? Start here.](#)

[Picture \(quality\)/screen](#)

[Keyboard](#)

[Broadcast reception](#)

[Sound](#)

[Network \(Internet\)/apps](#)

[Remote control/accessories](#)

[Power](#)

[Connected devices](#)

[LED](#)

[81] Troubleshooting

Start here

[Software updates](#)

[If a full reset \(restart\) of the TV is required](#)

[Frequently Asked Questions for Troubleshooting](#)

[82] Troubleshooting | Start here

Software updates

Sony will provide software updates from time to time in order to enhance functionality and provide users with the latest TV experience. The easiest way to receive software updates is via an internet connection to the TV.

If you want to check if your software is up-to-date, select [System update] from [Settings] — [System] — [About].

Updating software via USB storage device

If you do not have a network connection, you can also update the software by using a USB storage device. Use your computer to download the latest software from the Sony support website onto a USB storage device. Insert the USB storage device to a USB port on the TV and the software update will start automatically.

If you will update the TV software by using a USB storage device, you should read the cautions for update by USB storage device on the website.

For more information about the support site, please see the [Support Site](#) page.

Related topics

- [Connecting to a Network](#)

[83] Troubleshooting | Start here

If a full reset (restart) of the TV is required

If you have trouble such as the picture not displaying on the screen or the remote control not working, reset the TV with the following procedure.

If an external USB device is connected to the TV, disconnect the USB device from the TV before resetting.

Power Reset

1 Restart the TV with the remote control.

Press and hold the power button on the remote control and select [Restart].

The TV will turn off and then restart after about one minute.

2 Unplug the AC power cord (mains lead).

If the problem persists after step 1, unplug the TV power cord (mains lead) from the electrical outlet and wait for 2 minutes. Then plug the power cord (mains lead) back into the electrical outlet.

Hint

- Your personal settings and data will not be lost after the TV restarts.

Factory data reset

If the problem persists after a power reset, try a factory data reset.

Note

- Performing a factory reset will delete all of the TV's data and settings (such as Wi-Fi and wired network setting information, Google account and other login information, Google Play and other installed apps).

1 Press the  (Quick Settings) button on the remote control, then select [Settings] — [System] — [About] — [Reset] — [Factory data reset] — [Factory data reset].

2 Select [Erase everything].

After the factory reset process completes successfully, the TV will proceed into the Initial Setup wizard. You must agree to the Google Terms of Service and Google Privacy Policy.

[84] Troubleshooting | Start here

Frequently Asked Questions for Troubleshooting

For troubleshooting information, you can also refer to “Frequently Asked Questions” in our support site below.

- <http://www.sony.net/androidtv-faq/>
-

[85] Troubleshooting

Picture (quality)/screen

No color/Dark picture/Color is not correct/Picture is too bright.

Distorted picture./The screen flickers.

Picture size/Screen format/Wide mode changes automatically.

A black box appears on the screen.



High resolution HDR pictures are not displayed.

A message about an app asking for permission to access a TV function is displayed.

[86] Troubleshooting | Picture (quality)/screen

No color/Dark picture/Color is not correct/Picture is too bright.

Adjust color tone, brightness, picture quality on your TV from [Picture adjustments].

- Press the  (Quick Settings) button, then select [Picture settings] to make adjustments.
For details, refer to the [Display & Sound] page.
- If you want to reset the [Picture adjustments] settings, press the  (Quick Settings) button, and select [Picture settings] — [Advanced] — [Reset].
- If you set [Power saving] to [Low] or [High], the black level will be enhanced. Press the  (Quick Settings) button on the remote control, then select [Settings] — [System] — [Power and Energy] — [Power saving] to [Off] to brighten the screen.

Note

- Picture quality depends on the signal and content.
- The picture quality may improve if you change it in [Picture adjustments].
Press the  (Quick Settings) button, select [Picture settings] — [Advanced] — [Brightness], and adjust [Brightness] or [Contrast].

Related topics

- [Display & Sound](#)



[87] Troubleshooting | Picture (quality)/screen

Distorted picture./The screen flickers.

Check the connection and position of the antenna and peripheral devices

- Check the antenna/cable connection.
- Keep the antenna/cable away from other connecting cables.
- When installing an optional device, leave some space between the device and the TV.
- Make sure that the antenna is connected using a high quality 75-ohm coaxial cable.

Check the [Motion] setting

- Press the  (Quick Settings) button, and select [Picture settings] — [Advanced] — [Motion] — [Motionflow] — [Off].
(For [Motionflow] compatible models only)
[Motionflow] compatible models have [Motionflow] in [Picture settings] — [Advanced] — [Motion].
- Change the current setting of [CineMotion] to [Off].
Press the  (Quick Settings) button, and select [Picture settings] — [Advanced] — [Motion] — [CineMotion].

Related topics

- [Ghosting or double images appear.](#)

[88] Troubleshooting | Picture (quality)/screen

Picture size/Screen format/Wide mode changes automatically.

You can adjust the picture size from [Screen].

Press the  (Quick Settings) button on the remote control, then select [Settings] — [Display & Sound] — [Screen].

- You can manually adjust the picture size from [Wide mode].

Example of setting [Wide mode] (when the aspect ratio of the original picture is 4:3)

- [Auto]

When changing the channel or video input, if [Auto] in [Wide mode] is selected, the current [Wide mode] setting is automatically changed according to the input signal. To lock the [Wide mode] setting, choose other than [Auto] in [Wide mode].

- [Wide zoom]

Enlarges the picture, preserving the original picture as much as possible.

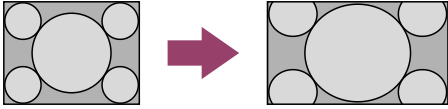

- [Normal]

Displays the original picture as is. Sidebars that fill in the difference with the 4:3 picture are displayed on the left and right sides of the screen.

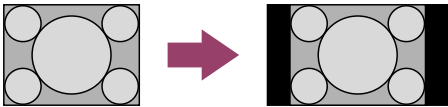

- [Full]

Enlarges the picture (with overscan) fit to panel, without preserving the original aspect ratio.

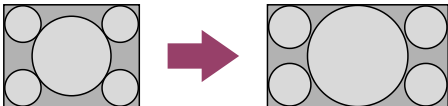

- [Full pixel]

Enlarges the picture (without overscan) fit to panel, without preserving the original aspect ratio.

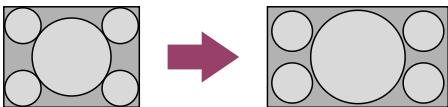

- [Zoom]

Displays a 16:9 picture that has been converted into 4:3 letter box format, in the correct aspect ratio.

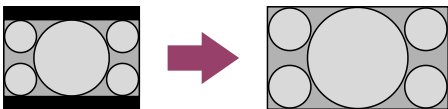

- [14:9]

Displays a 14:9 picture in its original size. Sidebars are shown to fill the 16:9 screen.

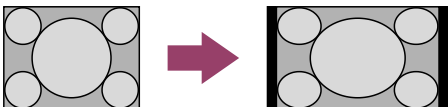

[Wide mode] (when the aspect ratio of the original picture is 16:9)

The picture may not be displayed as intended even if it has an aspect ratio of 16:9. Change the settings to switch to the desired display.

- [Auto]

When changing the channel or video input, if [Auto] in [Wide mode] is selected, the current [Wide mode] setting is automatically changed according to the input signal. To lock the [Wide mode] setting, choose other than [Auto] in [Wide mode].

- [Wide zoom]

Enlarges the picture, preserving the original picture as much as possible.



- [Normal]

Displays a 4:3 picture that was expanded horizontally into 16:9, in the correct aspect ratio.



- [Full]

Enlarges the picture (with overscan) fit to panel, without preserving the original aspect ratio.



- [Full pixel]

Enlarges the picture (without overscan) fit to panel, without preserving the original aspect ratio.



- [Zoom]

Displays a 16:9 picture that has been converted into 4:3 letter box format, in the correct aspect ratio.



- [14:9]

Displays a 14:9 picture in its original size. Sidebars are shown to fill the 16:9 screen.



Note

- [Auto] in [Wide mode] will not expand the picture while the content switches since the content information is regulated by the channel signal provider. You can manually change the [Wide mode] setting if desired, which will remain in effect until you change the channel/input or manually change the [Wide mode] setting again.
- The Picture size depends on the signal content.
 - The picture becomes smaller during commercials due to the method used by the provider to broadcast content. When HD content channels switch to SD content (commercials), the picture may become small with a black border.
 - Some wide screen programs are filmed in aspect ratios that are greater than 16:9 (this is especially common with theatrical releases). Your TV will show these programs with black bands at the top and bottom of the screen. For more details, check the documentation that came with your BD/DVD (or contact your program provider).
 - Programs broadcast in HD formats (720p and 1080i) with 4:3 content will commonly have black bands on the left and right sides of the screen which are added by the broadcaster.

Hint

- Some cable and satellite set-top boxes can also control the size of the picture. If you are using a set-top box, refer to the manufacturer of the set-top box for more information.

[89] Troubleshooting | Picture (quality)/screen

A black box appears on the screen.

- A text option is selected although no text is available. Check the [Captions] settings in [Accessibility], or [Captions] in [Channels & Inputs] — [Preferences (Channels)]. (Option name differs depending on your region/country.) You can select a different option from the current option.

[90] Troubleshooting | Picture (quality)/screen

High resolution HDR pictures are not displayed.

The following are required to watch high resolution HDR pictures such as 4K (50p/60p)*.

- Connect the 4K (50p/60p)* playable device.

- Use a Premium High Speed HDMI™ Cable(s) that supports 18 Gbps.
- Set [HDMI signal format] to [Enhanced format]/[Enhanced format (ALLM)] by selecting [Settings] — [Channels & Inputs] — [External inputs] — [HDMI signal format] — the HDMI terminal you want to set.
- Check whether the connected device has the latest settings or firmware.

* Availability depends on your model/region/country.

[91] Troubleshooting | Picture (quality)/screen

A message about an app asking for permission to access a TV function is displayed.

- Select whether to allow or deny the app access to the displayed function.
- You can check the list of app permissions categorized by TV function and change permission settings for each app. Press the  (Quick Settings) button on the remote control, then select [Settings] — [Apps] — [App permissions] — the desired TV function.

[92] Troubleshooting

Keyboard

You cannot operate the current screen after the on-screen keyboard is displayed.

- To return to operation of the screen behind the on-screen keyboard, press the  (Back) button on the remote control.

[93] Troubleshooting

Broadcast reception

Check these things first to troubleshoot your TV reception.

Block noise or an error message appears and you cannot watch broadcasts.

Ghosting or double images appear.

Only snow noise or a black picture appears on the screen.

There is picture or sound noise when viewing an analog TV channel.

Some channels are blank.

Poor reception or poor picture quality with digital broadcasts.

You cannot view digital channels.

You cannot receive or select channels.

Some digital cable channels are not displayed.

Broadcast HD formats have poor quality.

[94] Troubleshooting | Broadcast reception

Check these things first to troubleshoot your TV reception.

- Make sure that the antenna cable is firmly connected to the TV.
 - Make sure that the antenna cable is not loose or disconnected.
 - Make sure that the cable or cable connector of antenna is not damaged.
- To watch streaming content, connect the TV to the Internet.

Hint

- For more information, please visit the Sony support website.
[Support Site](#)

Related topics

- [Using Wi-Fi to connect the TV to the Internet/Network](#)
- [Connecting to a network using a LAN cable](#)

[95] Troubleshooting | Broadcast reception

Block noise or an error message appears and you cannot watch broadcasts.

- Make sure that the antenna cable is connected to the correct ports (at the TV/connected devices/wall).

- Make sure that the cable is not old or that the inside of the connector is not short-circuited.

[96] Troubleshooting | Broadcast reception

Ghosting or double images appear.

- Check cable or antenna connections.
- Check the antenna location and direction.
- Press the  (Quick Settings) button, and select [Picture settings] — [Advanced] — [Motion] — [Motionflow] — [Off].
(For [Motionflow] compatible models only)
[Motionflow] compatible models have [Motionflow] in [Picture settings] — [Advanced] — [Motion].

Related topics

- [Distorted picture./The screen flickers.](#)
- [Check these things first to troubleshoot your TV reception.](#)

[97] Troubleshooting | Broadcast reception

Only snow noise or a black picture appears on the screen.

- Check if auto tuning is performed.
- Check if the antenna is broken or bent.
- Check if the antenna has reached the end of its serviceable life (3-5 years for normal use, 1-2 years at a seaside location).

Related topics

- [Check these things first to troubleshoot your TV reception.](#)

[98] Troubleshooting | Broadcast reception

There is picture or sound noise when viewing an analog TV channel.

- Make sure that the antenna is connected using a high quality 75-ohm coaxial cable.
- Keep the antenna cable away from other connecting cables.

Related topics

- [Check these things first to troubleshoot your TV reception.](#)

[99] Troubleshooting | Broadcast reception

Some channels are blank.

- The channel is for scrambled/subscription service only. Subscribe to a pay TV service.
- The channel is used only for data (no picture or sound).
- Contact the broadcaster for transmission details.

Related topics

- [Check these things first to troubleshoot your TV reception.](#)

[100] Troubleshooting | Broadcast reception

Poor reception or poor picture quality with digital broadcasts.

- Change the position, direction and angle of the terrestrial television antenna to maximize the antenna signal level. Make sure that the direction of the antenna is not changed unintentionally (such as by wind).
- If you are using a TV signal booster, adjust its signal gain.
- If equipment (such as a TV signal distributor) is connected between the antenna and the TV, it may affect the TV reception. Directly connect the antenna and the TV to check if the reception is improved.

Related topics

- [Check these things first to troubleshoot your TV reception.](#)

[101] Troubleshooting | Broadcast reception

You cannot view digital channels.

- Ask a local installer if digital transmissions are provided in your area.
- Upgrade to a higher gain antenna.

Related topics

- [Check these things first to troubleshoot your TV reception.](#)
- [You cannot receive or select channels.](#)
- [Some digital cable channels are not displayed.](#)

[102] Troubleshooting | Broadcast reception

You cannot receive or select channels.

- Perform [Analog auto tuning] / [Digital auto tuning] to add receivable channels that are not present in the TV memory.

You may tune Analog or Digital service to check the available channel.

Press the  (Quick Settings) button on the remote control, then select [Settings] — [Channels & Inputs] — [Channels] — [Channel Setup] — [Analog] / [Digital] — [Analog auto tuning] / [Digital auto tuning].

- Check that [Signal type] is set correctly.

You may try to setup Cable or Antenna to check the available signal.

Press the  (Quick Settings) button on the remote control, then select [Settings] — [Channels & Inputs] — [Channels] — [Channel Setup] — [Signal type].

[Cable]

Set to receive and select cable channels.

[Antenna]

Set to receive and select antenna channels.

Related topics

- [Some channels are blank.](#)
- [You cannot view digital channels.](#)
- [Some digital cable channels are not displayed.](#)

[103] Troubleshooting | Broadcast reception

Some digital cable channels are not displayed.

- Certain cable companies have limitations on the broadcast of digital cable channels. Check with your cable company for more information.
- The digital cable channel may be hidden under [Shown channels] under [Preferences (Channels)].

Related topics

- [Check these things first to troubleshoot your TV reception.](#)
- [You cannot view digital channels.](#)

[104] Troubleshooting | Broadcast reception

Broadcast HD formats have poor quality.

- Content and signal quality are regulated by the signal provider. Many HD channels and content are actually upscaled versions of standard-definition broadcasts. The picture is affected by the quality of the signal received, which varies between channel and program.

Related topics

- [Check these things first to troubleshoot your TV reception.](#)

[105] Troubleshooting

Sound

[No sound but good picture.](#)

Audio noise.

No audio or low audio with a home theater system.

Distorted sound.





You want to output sound from the headphones/Bluetooth audio device and audio system/TV speakers at the same time.

You are concerned about a delay between the picture and sound.

You cannot establish an eARC connection (only models equipped with an HDMI IN (eARC/ARC) terminal).

[106] Troubleshooting | Sound

No sound but good picture.

- Check the volume control.
- Press the  (Mute) or  (Volume) + button to cancel muting.
- Press the  (Quick Settings) button, then select [Speakers] — [TV speakers].
Press the  (Quick Settings) button on the remote control, then select [Settings] — [Display & Sound] — [Audio output] — [Speakers] — [TV speakers].
- If headphones are connected, sound is not output from the TV speakers or audio system connected via ARC/eARC (only models equipped with an HDMI IN (eARC/ARC) terminal). Remove the headphones.

Related topics

- [No audio or low audio with a home theater system.](#)

[107] Troubleshooting | Sound

Audio noise.

- Make sure that the antenna is connected using a high quality 75-ohm coaxial cable.
- Keep the antenna cable away from other connecting cables.
- To avoid TV interference, make sure to use an undamaged antenna cable.

Related topics

- [Distorted sound.](#)

[108] Troubleshooting | Sound

No audio or low audio with a home theater system.

- Press the  (Quick Settings) button, then select [Speakers] — [Audio system].
- If the audio system is not compatible with Dolby Digital, set [Settings] — [Display & Sound] — [Audio output] — [Digital Audio Out] to [PCM].
- Check if the [Digital audio out volume] setting of the TV is at maximum.

Press the  (Quick Settings) button, then select [Sound settings] — [Advanced] — [Common] — [Digital audio out volume].

- When using HDMI input with Super Audio CD or DVD-Audio, DIGITAL AUDIO OUT (OPTICAL) may not provide an audio signal.

Related topics

- [Audio noise.](#)
- [Connecting an audio system](#)

[109] Troubleshooting | Sound

Distorted sound.

- Check the antenna/cable connection.
- Keep the antenna/cable away from other connecting cables.
- Keep the TV away from electrical noise sources such as cars, hair-dryers, Wi-Fi units, mobile phones, or optical devices.
- When installing an optional device, leave some space between the device and the TV.

Related topics

- [Audio noise.](#)

[110] Troubleshooting | Sound

You want to output sound from the headphones/Bluetooth audio device and audio system/TV speakers at the same time.

To output sound from both the headphones/Bluetooth audio device and TV speakers

The TV cannot output sound from both the headphones or Bluetooth audio device and the TV speakers at the same time.

To output sound from both an audio system connected via eARC/ARC (only models equipped with an HDMI IN (eARC/ARC) terminal) and TV speakers

Sound can be output from both an audio system connected to the TV and the TV speakers at the same time by satisfying the following conditions.

- Connecting the TV and audio system using a digital optical cable
- Setting [Digital Audio Out] to [PCM]

For details about digital optical cable connections, refer to the [Connecting an audio system](#) page.

[111] Troubleshooting | Sound

You are concerned about a delay between the picture and sound.

If a specific audio system is connected with an HDMI cable

You can adjust the output timing of the picture and sound. For details about supported models, refer to the support site.

- [Support Site](#)

Related topics

- [Adjusting an audio system](#)

[112] Troubleshooting | Sound

You cannot establish an eARC connection (only models equipped with an HDMI IN (eARC/ARC) terminal).

- Connect the audio system to an HDMI cable with Ethernet.
- Connect the audio system to the TV's HDMI input terminal bearing the text "ARC" or "eARC/ARC".
- Configure the settings as follows.
[Settings] — [Display & Sound] — [Audio output] — [Speakers] — [Audio system]
- Enable the audio system's eARC feature.

Related topics

- [Connecting an audio system](#)

[113] Troubleshooting

Network (Internet)/apps

The TV cannot connect to the Internet/Network.

The picture and/or sound quality from streaming apps is poor.

You can connect to the Internet, but not to certain apps and services.

[114] Troubleshooting | Network (Internet)/apps

The TV cannot connect to the Internet/Network.

If the wireless network does not connect or disconnects, try the following.

- Press the  (Quick Settings) button on the remote control and check that the following setting is enabled.
[Settings] — [Network & Internet] — [Wi-Fi]

- Check the installation location of the TV and wireless router. Signal condition may be affected by the following:
 - Other wireless devices, microwaves, fluorescent lights, etc., are placed nearby.
 - There are floors or walls between the wireless router and TV.
- Turn the wireless router off and then on again.
- If the network name (SSID) of the wireless router to which you want to connect is not displayed, select [Add new network] under [Other options] to enter a network name (SSID).

If the problem is not resolved even after the procedures above or if you cannot connect even with a wired network, check the status of the network connection.

Checking the status of the network connection

- 1 Press the  (Quick Settings) button on the remote control, then select [Settings] — [Network & Internet] — [Network status] — [Check Connection]. Check your network connections and/or server's instruction manual for connection information, or contact the person who set up the network (network administrator).

Hint

- The solution varies depending on the network status check. For solutions based on each issue, see "[Frequently Asked Questions](#)" on the Sony Support Site.

Note

- If the LAN cable is connected to an active server and the TV has acquired an IP address, check your server's connections and configurations.

Press the  (Quick Settings) button on the remote control, then select [Settings] — [Network & Internet] — [Network status].

Related topics

- [Using Wi-Fi to connect the TV to the Internet/Network](#)
- [Connecting to a network using a LAN cable](#)

The picture and/or sound quality from streaming apps is poor.

- Quality depends on the original video provided by the video content provider and your connection bandwidth.
- To enjoy watching Internet streaming videos, a network with a fast and stable line speed is necessary. In general, speeds that resemble the following are necessary:
 - Streaming standard definition (SD) Internet video: 2.5 Mbps
 - Streaming high definition (HD) Internet video: 10 Mbps
 - Streaming Ultra HD (4K) Internet video: 25 Mbps
- The wireless network connection quality varies depending on the distance or obstacles (e.g., wall) between the TV and the wireless router, environmental interference, and the quality of the wireless router. In this case, use a wired connection for the Internet, or try the 5 GHz band.
- The 5 GHz band may not be supported depending on your region/country. If the 5 GHz band is not supported, the TV can only connect to a wireless router using the 2.4 GHz band.
- When using a wireless network, keep wireless devices close together or avoid obstacles.
- Keep devices that emit RF interference (such as microwaves) away from the TV and wireless router, or turn off such devices.
- Audio is not output for videos without audio.

Hint

- For more information, please visit the Sony support website.

[Support Site](#)

Related topics

- [Connecting to a network using a LAN cable](#)
- [Using Wi-Fi to connect the TV to the Internet/Network](#)

[116] Troubleshooting | Network (Internet)/apps

You can connect to the Internet, but not to certain apps and services.

- The date and time settings of this TV may be incorrect. Depending on certain apps and services, you may not be able to connect to those apps and services if the time is incorrect.

If the time is incorrect, press the  (Quick Settings) button on the remote control, then select [Settings] — enable [Automatic date & time] in [System] — [Date & Time].

- Check that the LAN cable and AC power cord (mains lead) of the router/modem* has been properly connected.

* Your router/modem must first be setup to connect to the Internet. Contact your Internet service provider for router/modem settings.

- Try using the apps later. The app content provider's server may be out of service.

Hint

- For more information, please visit the Sony support website.

[Support Site](#)

Related topics

- [Connecting to a network using a LAN cable](#)
- [Using Wi-Fi to connect the TV to the Internet/Network](#)

[117] Troubleshooting

Remote control/accessories

The remote control does not operate.

[118] Troubleshooting | Remote control/accessories

The remote control does not operate.

Check if the TV is working properly

- Press the power button on the TV to determine if the problem is with the remote control or not. For the location of the power button, refer to the Reference Guide/Setup Guide supplied with the TV.
- If the TV is not working, try resetting it.

If a full reset (restart) of the TV is required

Check if the remote control is working properly

- Point the remote control at the remote control sensor located at the front of the TV.
- Keep the remote control sensor area clear from obstacles.
- Fluorescent light can interfere with remote control operation; try turning off any fluorescent light.
- Check that the orientation of each battery matches the positive (+) and negative (-) symbols in the battery compartment.
- Battery power may be low. Remove the remote control cover and replace the batteries with new ones.

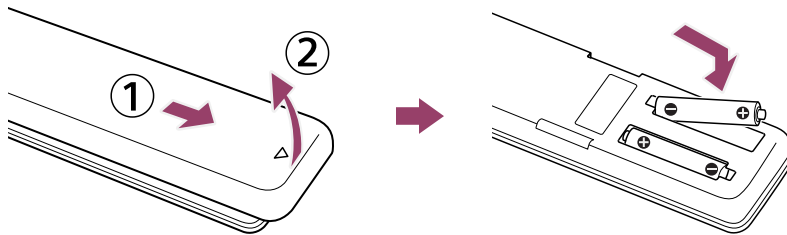

Reset the remote control

If the remote control does not operate correctly due to poor battery contact or static electricity, the problem may be resolved by resetting the remote control.

- 1 Remove the batteries from the remote control.**
- 2 Press the power button on the remote control for three seconds.**
- 3 Install new batteries into the remote control.**

If the problem persists, refer to the If a full reset (restart) of the TV is required and Frequently Asked Questions for Troubleshooting pages.

Note

- When you unplug the TV and plug it in again, the TV may not be able to turn on for a while, even if you press the power button on the remote control or the TV. This is because it takes time to initialize the system. Wait for about 10 to 20 seconds, then try again.
- When you cannot search using your voice, activate the Google Assistant button by pressing the  (Quick Settings) button on the remote control and selecting [Settings] — [Remotes & Accessories] — [Remote control] — [Connect via Bluetooth].

Related topics

- [Using the remote control](#)
- [Using the remote control microphone](#)

[119] Troubleshooting

Power

[The TV turns off automatically.](#)

[The TV turns on automatically.](#)

[The TV does not turn on.](#)

[120] Troubleshooting | Power

The TV turns off automatically.

- The screen may have been turned off due to [Sleep timer] settings.
 - Check if [Idle TV power off]/[Auto shut-off] in [Power and Energy] is activated.
-

[121] Troubleshooting | Power

The TV turns on automatically.

- Disable the [TV auto power on] setting in [HDMI CEC Settings].

Related topics

- [CEC-compatible devices](#)

[122] Troubleshooting | Power

The TV does not turn on.

Perform the procedures in the order below until the problem is solved.

1. Check if the TV turns on with the remote control.

Point the remote control at the sensor on the front of the TV and press the power button on the remote control.

Check if the TV turns on or if the illumination LED lights up.

If the illumination LED lights up but the TV does not turn on, try resetting (restarting) the TV.

- [If a full reset \(restart\) of the TV is required](#)

2. Check if the TV turns on with the power button on the TV.

Press the power button on the TV and check if the TV turns on. The power button is on the side or back of the TV.

For details, refer to the Reference Guide/Setup Guide of the TV.

If the TV turns on with this procedure, there may be a problem with the remote control.

Refer to the following topic.

- [The remote control does not operate.](#)

3. Unplug the AC power cord (mains lead) and wait for 2 minutes.

Unplug the TV power cord (mains lead) from the electrical outlet and wait for 2 minutes.

Then plug the power cord (mains lead) back into the electrical outlet. After 20 seconds, press the power button on the remote control or TV.

Hint

- When you unplug the TV and plug it in again, the TV may not be able to turn on for a while, even if you press the power button on the remote control or the TV. This is

because it takes time to initialize the system. Wait for about 10 to 20 seconds, then try again.

Related topics

- [The remote control does not operate.](#)
- [If a full reset \(restart\) of the TV is required](#)

[123] Troubleshooting

Connected devices

[No picture from a connected device.](#)

[Certain programs on digital sources display a loss of detail.](#)

[Photo images or folders take time to display.](#)

[You cannot find a connected HDMI CEC device.](#)



[Some media files in the USB device are not displayed.](#)

[Operation cuts out, or a device does not work.](#)

[Some paid content cannot be played.](#)

[124] Troubleshooting | Connected devices

No picture from a connected device.

- Turn the connected device on.
- Check the cable connection between the device and TV.
- Press the  (Input) button to display the list of inputs, then select the desired input.
- Correctly insert the USB device.
- Make sure that the USB device has been properly formatted.
- Operation is not guaranteed for all USB devices. Also, operations differ depending on the USB device features or the video files being played.
- Change the HDMI signal format of the HDMI input that does not display a picture to standard format. Press the  (Quick Settings) button on the remote control, then select [Settings] — [Channels & Inputs] — [External inputs] — [HDMI signal format] — the HDMI input you want to set.

Related topics

- [Using the TV with Other Devices](#)

[125] Troubleshooting | Connected devices

Certain programs on digital sources display a loss of detail.

- Less detail than usual or artifacts (small blocks, dots or pixelation) may appear on the screen, due to the digital compression of the source content used by certain digital broadcasts and DVDs. The degree of visible artifacts depends on the clarity and resolution of the TV.

[126] Troubleshooting | Connected devices

Photo images or folders take time to display.

- Depending on the image dimension, file size, and number of files in a folder, some photo images or folders take time to display.
- Each time a USB device is connected to the TV, it may take up to a couple of minutes for the photos to display.

Related topics

- [No picture from a connected device.](#)

[127] Troubleshooting | Connected devices

You cannot find a connected HDMI CEC device.

- Check that your device is CEC-compatible.
- Make sure that CEC is enabled on the CEC-compatible device, and [Settings] — [Channels & Inputs] — [External inputs] — [HDMI CEC Settings] — [CEC] is set up on the TV.

Related topics

- [CEC-compatible devices](#)

[128] Troubleshooting | Connected devices

Some media files in the USB device are not displayed.

- Unsupported files may not be displayed.

Related topics

- [Supported files and formats](#)

[129] Troubleshooting | Connected devices

Operation cuts out, or a device does not work.

- Check if the device is turned on.
- Replace the batteries of the device.
- Re-register the device.
- Bluetooth devices use the 2.4 GHz band, therefore communication speed may deteriorate or cut out occasionally due to wireless LAN interference.
If household electric appliances (e.g., microwaves or mobile devices) are placed nearby, radio wave interference is more likely to happen.
- The TV or device may not work on a metal rack due to wireless communication interference.
- For usable communication distances between the TV and other devices, refer to the instruction manuals of the devices.
- When multiple Bluetooth devices are connected to the TV, the quality of Bluetooth communication may deteriorate.

Related topics

- [Bluetooth devices](#)

[130] Troubleshooting | Connected devices

Some paid content cannot be played.

- The source device needs to meet HDCP (High-bandwidth Digital Content Protection) 2.3 standards.

Some pay contents may not be displayed via a source device which does not meet HDCP 2.3 standards.

[131] Troubleshooting

LED

[The illumination LED sometimes lights up.](#)

[132] Troubleshooting | LED

The illumination LED sometimes lights up.

The illumination LED lights up at various times such as during software updates using a USB storage device.

Refer to [How the LED lights up](#) for details.

[133]

Index

TV programs

-  [\(Guide\)](#)
- [Channel Setup](#)
- [Parental controls](#)

Picture/display

- [4K pictures](#)
- [Home menu](#)
- [Picture adjustments](#)
- [Date & Time](#)

- [Language](#)

Sound/voice

- [Voice search, using](#)
- [Sound adjustments](#)
- [Speech recognition](#)

Remote control

- [Remote control, using](#)
- [Voice search](#)
- [🏠 \(Home\)](#)
- [Quick Settings](#)
- [Inputs](#)

Connections

- [Bluetooth](#)
- [Google Cast](#)
- [CEC](#)
- [Internet](#)

External devices

- [Blu-ray/DVD players, connecting](#)
- [USB memory devices, etc.](#)
- [Computers](#)
- [Digital cameras, camcorders](#)
- [Audio systems](#)

Apps

- [Google Play Store](#)
- [YouTube](#)
- [Netflix](#)

File playback

- [Computers](#)
- [Digital cameras, camcorders](#)

- [Supported files and formats](#)

Other

- [Restart](#)
- [Accessibility](#)

- [System software update](#)
-