



VARI*LITE

VL800

EVENTPROFILE

USER MANUAL

INTRODUCTION

OUR GOAL

We are committed to providing you the highest quality in customer service. Our comprehensive resources are available to help your business succeed and ensure you get the full benefit of being a Vari-Lite customer.

TECHNICAL SUPPORT

Our Service and Support team is tasked with online and field support, repair, demo, commissioning, maintenance contracts, and technical training for fixtures and systems. In addition, this team plays a large role in a Systems sales, responsible for administering final commissioning, record-keeping, and organizing services. Refer to the back cover of this User Manual for contacts in your region or visit www.vari-lite.com/support.

CUSTOMER SERVICE

Customer Service is responsible for boxed goods and spare parts quotations, order entry and fulfilment, project delivery, lead times, and general account management. They also manage all after sales warranty fulfilment, RGA, and repairs invoicing in tandem with our After Sales Service & Support team. Visit our website to find a customer service agent in your region.

ADDITIONAL DOCUMENTATION

Additional product documentation, including DMX maps, software, and photometric reports, are available for download on our website.

For more information on installing DMX512 control systems, the following publication is available for purchase from the United States Institute for Theatre Technology (USITT), "Recommended Practice for DMX512: A Guide for Users and Installers, 2nd edition" (ISBN: 9780955703522).

USITT Contact Information:

USITT

315 South Crouse Avenue, Suite 200

Syracuse, New York 13210-1844 USA

Phone: 800-938-7488 or +1-315-463-6463

Fax: 866-398-7488 or +1-315-463-6525

Website: www.usitt.org

ABOUT THIS DOCUMENT

Read all instructions before installing or using this product. Retain this User Manual for future reference.

Additional product information and descriptions may be found on the product data sheet(s) which can be downloaded from the Vari-Lite website at www.vari-lite.com.

This User Manual provides necessary information regarding safety, installation, operation and routine maintenance for Vari-Lite VL800. Familiarizing yourself with this information will help you to get the most out of your product.

WARNING: It is important to read ALL accompanying safety and installation instructions to avoid damage to the product and potential injury to yourself or others.

SAFETY WARNINGS AND NOTICES

Read this user manual in full before attempting to install, operate or maintain the fixture to which it relates. This user manual is intended to provide general guidance to such suitably qualified personnel. Installation and operation of the fixture are to be performed by qualified personnel only.

When using electrical equipment, basic safety precautions should always be followed including the following:

READ AND FOLLOW ALL SAFETY INSTRUCTIONS.

- For indoor, dry location use only. Do not use outdoors unless fixture is suitably IP rated.
- Use safety tether when mounting.
- Equipment should be mounted in locations and at heights where it will not be readily subjected to tampering by unauthorized personnel.
- Not for residential use. Do not use this equipment for other than intended use.
- Note distance requirement(s) from combustible materials or illuminated objects. Do not mount near gas or electric heaters.
- Install only in locations with adequate ventilation. Ensure sure that ventilation slots are not blocked.
- Ensure that the voltage and frequency of the power supply match the power requirements of the fixture.
- The fixture must be earthed/grounded to the appropriate conductor.
- Do not operate fixture outside the specified ambient temperature range.
- Do not connect the fixture to any dimmer pack.
- The use of accessory equipment not recommended by the manufacturer may cause an unsafe condition and void warranty.
- Refer service to qualified personnel. This fixture contains no user serviceable parts.
- Prior to first use, carefully inspect fixture to ensure no damage has occurred during shipping.
- Materials used in the manufacturing process can cause strong odors when the product is new. These odors dissipate over time.
- Prior to each use, carefully inspect power cables and replace any damaged cables.
- Exterior surfaces of the luminaire will be hot during operation. Take appropriate precautions.
- Continuous use of the fixture may shorten the lifespan. Power down the fixture when not in use.
- Do not cycle power on and off repeatedly. Disconnect mains power if the fixture is not used for an extended period.
- Clean fixtures regularly, particularly when working in a dusty environment.
- Never touch power cables or wires while the fixture is powered on.
- Avoid entangling power wires with other cables.
- In the event of a serious operating problem, immediately discontinue using the fixture.
- It is hazardous to operate luminaires without lens or shield. Shields, lenses, or ultraviolet screens shall be changed if they have become visibly damaged to such an extent that their effectiveness is impaired, for example, by cracks or deep scratches.
- Original packing materials can be reused for transporting the fixture.
- Do not look directly at the LED light beam while the fixture is on.
- This is a Class A product. In a domestic environment this product may cause radio interference, in which case, the user may be required to take adequate measures.
- The light source contained in this luminaire shall only be replaced by the manufacturer or service agent or similarly qualified person.

SAVE THESE INSTRUCTIONS.

WARNING: Refer to National Electrical Code® and local codes for cable specifications. Failure to use proper cable can result in damage to equipment or danger to personnel. Caution Against Direct Sunlight Through Front Lens Assembly

COMPLIANCE NOTICE



FCC DECLARATION OF CONFORMITY

This equipment has been tested and found to comply with the limits for a Class A digital device pursuant to Part 15 of FCC Rules. These limits are designed to provide reasonable protection against harmful interference when this equipment is operated in a commercial environment. This equipment generates, uses, and can radiate radio frequency energy and, if not installed and used in accordance with Vari-Lite Strand system, service, and safety guidelines, may cause harmful interference to radio communications.

As tested under this standard:

FCC 47CFR 15B cIA*CEI

Issued:2009/10/01 Title 47 CFR Part 15 Subpart B Unintentional Radiators Class A

Operation of this equipment in a residential area is likely to cause harmful interference, in which case the user will be required to correct the interference at his/her own expense.



EU DECLARATION OF CONFORMITY

We, Vari-Lite LLC., 10911 Petal Street, Dallas, Texas 75238, declare under our responsibility for the products contained herein are in conformity with the essential requirements of the following European Directives and harmonized standards:

Low Voltage Director (LVD), 2006/95/EC

EN 60589-2-17:1984+A1:1987+A2:1990 used in conjunction with 60598-1:2008/A11:2009

Electromagnetic Compatibility Directive (EMC), 2004//108/EC

EN 55022:2010, EN55024:2010

HOW TO OBTAIN WARRANTY SERVICE

A copy of the Limited Warranty card was included in the shipping package for this product.

To obtain warranty service, please contact customer service at 1-214-647-7880, or **entertainment.service@signify.com** and request a Return Material Authorization (RMA) for warranty service. You will need to provide the model and serial number of the item being returned, a description of the problem or failure and the name of the registered user or organization. If available, you should have your sales invoice to establish the date of sale as the beginning of the warranty period. Once you obtain the RMA, pack the unit in a secure shipping container or in its original packing box. Be sure to clearly indicate the RMA number on all packing lists, correspondence, and shipping labels. If available, please include a copy of your invoice (as proof of purchase) in the shipping container.

With the RMA number written legibly on or near the shipping address label, return the unit, freight prepaid, to:

Vari-Lite LLC
Attention: Warranty Service (RMA# _____)
10911 Petal Street
Dallas, Texas 75238
USA

As stated in the warranty, it is required that the shipment be insured and FOB our service center.

IMPORTANT! When returning products to Vari-Lite for repairs (warranty or out-of-warranty) from a country other than the USA, "Vari-Lite LLC", must appear in the address block as the Importer of Record (IOR) on all shipping documentation, Commercial Invoices, etc. This must be done in order to clear customs in a timely manner and prevent returns.

1 DESCRIPTION

FEATURES

- High output LED
- Full CMY-CTO color mixing
- Static and rotating gobo wheels, prism, frost, and iris
- Multi-mode fan control
- Adjustable frequency to exceed camera frame rates

Download the product datasheet from the Vari-Lite website at www.vari-lite.com for full technical specifications.

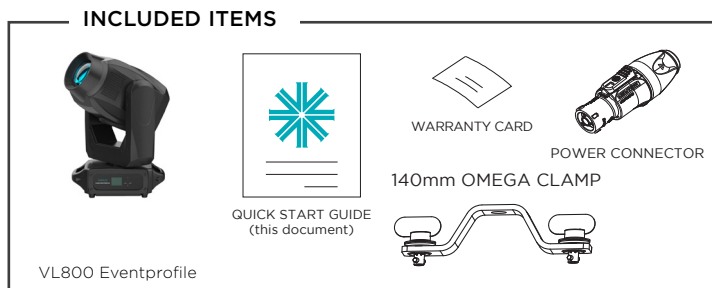

COMPONENTS

LUMINAIRE OVERVIEW

The following illustration shows the external luminaire components and controls.

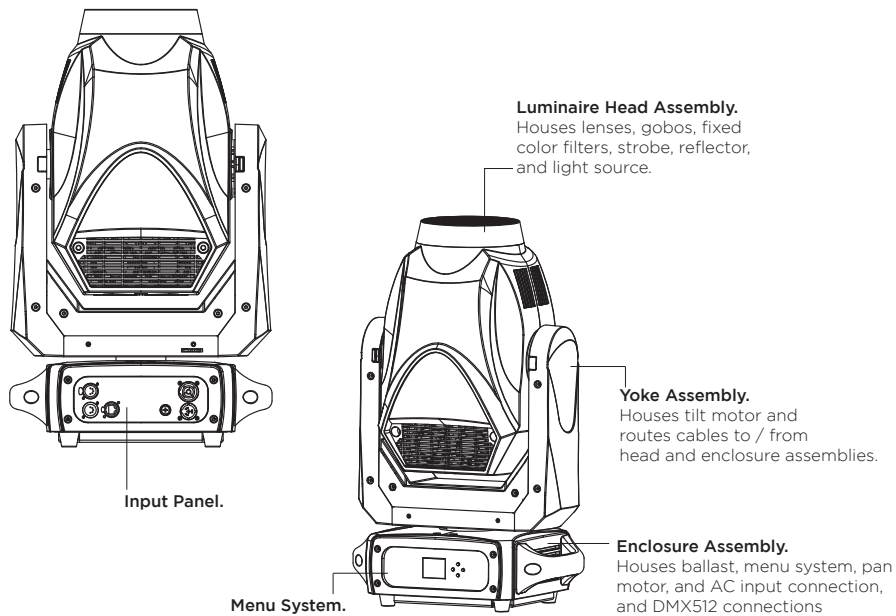

2 INSTALLATION

MOUNTING

The unit should be mounted via its screw holes on the bracket. Always ensure that the unit is firmly fixed to avoid vibration and slipping while operating. Always ensure that the structure to which you are attaching the unit is secure and can support a weight of 10 times of the unit's weight. Also always use a safety cable that can hold 12 times of the weight of the unit when installing the fixture. Use M12 screw to fasten the clamp to the Quick-lock fastener.

The equipment must be installed by professionals. And it must be installed at a place where is out of the touch of people and has no one pass by or under it.

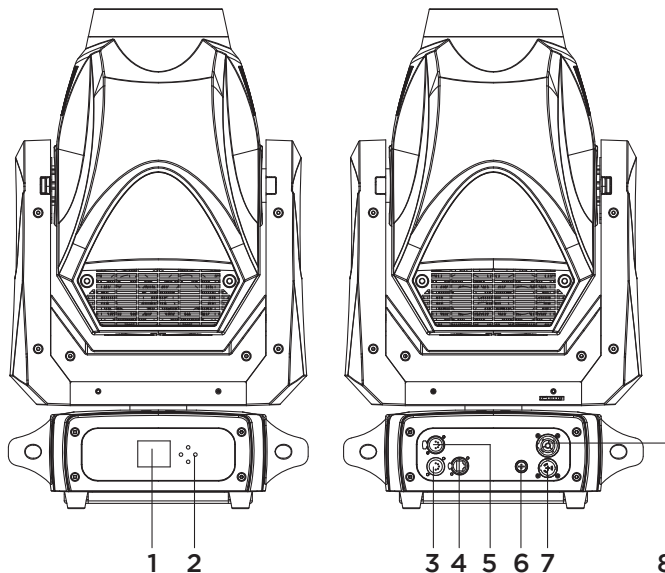
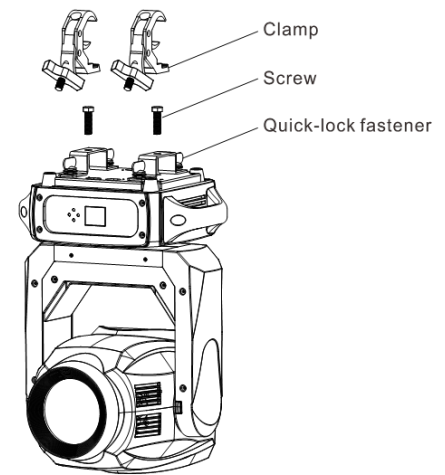

1 Display. Shows menu and selected functions

2 Buttons.

- MENU To select the programming functions
- UP To go backward in the selected functions
- DOWN To go forward in the selected functions
- ENTER To confirm the selected functions

3 DMX/RDM input. Connectors for DMX 512 operation, 5-pin XLR cable to link the DMX console

4 DMX/RDM thru. Connectors for DMX 512 operation, 5-pin XLR cable to link the next unit

5 Ethernet. Transfers fixture's information to a main controller

6 Fuse (T 10A). Protects the unit from damage of overcurrent

7 Power Input. Connects to supply power.

8 Power Thru. Connects to the next fixture.

3 DMX MAPPING

DMX CHANNELS

CHANNEL MAPPING

The following tables assumes a DMX start address of 1. When a different starting address is used, this address becomes channel 1 function and other functions follow in sequence.

TABLE 1.16-BIT ENHANCED

DMX	PARAMETER	DEFAULTS	RANGE	DESCRIPTION
1	Intensity High	0	0-65535	16-bit control of Dimming
2	Intensity Low			
3	Pan High	32767	0-65535	540° Total Pan Rotation
4	Pan Low			
5	Tilt High	32767	0-65535	270° Total Tilt
6	Tilt Low			
7	Focus High	32767	0-65535	Focus control Default value 50% Focus range
8	Focus Low			
9	Zoom High	128	0-255	Zoom control Default value 50% zoom range
10	Cyan	0	0 - 255	Cyan Color Control 0-100% saturation
11	Yellow	0	0 - 255	Yellow Color Control 0-100% saturation
12	Magenta	0	0 - 255	Magenta Color Control 0-100% saturation
13	CTO	0	0 - 255	CTO Color correction Control 0-100% saturation
14	Color Wheel	0	0 - 255	8-bit control of Color Wheel. (spin speed slow to fast from control channel) OPEN (centered at 0)
			0-31	Open
			32-63	VL RED Centre - 48
			64-95	Dark Blue Centre - 80
			96-127	Yellow Centre - 112
			128-159	Kelly Green Centre - 144
			160-191	Amber Centre 176
			192-223	Congo Blue Centre 208
224-255	Open			
15	Color Wheel Control	0	0 - 255	
			0 - 5	Linear Movement using shortest (quickest) path.
			6 - 10	Linear Movement using normal (longest) path.
			11 - 15	Wheel Spin CW (Forward)
			16 - 20	Wheel Spin STOP
			21 - 25	Wheel Spin CCW (Reverse)
			26 - 56	Color Shake Quickest Path (Slow to Fast) For fastest shake set color timing to 0
			57 - 87	Color Shake Normal Path (Slow to Fast) For fastest shake set color timing to 0
88 - 255	Reserved Values			

TABLE 1.16-BIT ENHANCED

DMX	PARAMETER	DEFAULTS	RANGE	DESCRIPTION
16	Gobo Wheel 1	0	0 - 255	8-bit control of Gobo Wheel 1. See Channel 20 for control options. Interchangeable glass gobos
			0 - 5	Open - No Gobo
			6 - 10	Gobo 1 (Night Sky) Index
			11 - 15	Gobo 2 (Circle of Ovals) Index
			16 - 20	Gobo 3 (Bricked Out) Index
			21 - 25	Gobo 4 (Neurons) Index
			26 - 30	Gobo 5 (Swirl) Index
			31 - 35	Gobo 6 (Crossed-Bars) Index
			36 - 40	Gobo 7 (On the Rock) Index
			41 - 45	Open - No Gobo
			46 - 50	Gobo 1 (Night Sky) Rotate
			51 - 55	Gobo 2 (Circle of Ovals) Rotate
			56 - 60	Gobo 3 (Bricked Out) Rotate
			61 - 65	Gobo 4 (Neurons) Rotate
			66 - 70	Gobo 5 (Swirl) Rotate
			71 - 75	Gobo 6 (Crossed-Bars) Rotate
			76 - 80	Gobo 7 (On the Rock) Rotate
			81 - 85	Open - No Gobo
			86 - 90	Gobo 1 (Night Sky) Rotate with Mega Stepping
			91 - 95	Gobo 2 (Circle of Ovals) Rotate with Mega Stepping
96 - 100	Gobo 3 (Bricked Out) Rotate with Mega Stepping			
101 - 105	Gobo 4 (Neurons) Rotate with Mega Stepping			
106 - 110	Gobo 5 (Swirl) Rotate with Mega Stepping			
111 - 115	Gobo 6 (Crossed-Bars) Rotate with Mega Stepping			
116 - 120	Gobo 7 (On the Rock) Rotate with Mega Stepping			
121 - 255	Reserved Values			
17	Gobo 1 Rot/Index High Byte	32767	0 - 65535	16-bit control of index and rotation of gobo wheel 1.
18	Gobo 1 Rot/Index Low Byte		0 - 32756	Rotate Fast to Slow <<<
			32757 - 32780	Rotation STOP
			32781 - 65535	Rotate Slow to Fast >>>
19	Gobo Wheel 1 Control	0	0 - 255	Used as a control channel for different movement options for Gobo Wheel 1 (Channel 17)
			0 - 5	Gobo Selection using shortest (quickest) path.
			6 - 10	Gobo Selection using normal (longest) path.
			11 - 20	Reserved Values
			21 - 50	Wheel Spin CW Forward (Fast to Slow)
			51 - 60	Wheel Spin STOP
			61 - 90	Wheel Spin CCW Reverse (Slow to Fast)
			91 - 120	Gobo Shake Quickest Path (Slow to Fast) For fastest shake set gobo timing to 0
			121 - 150	Gobo Shake Normal Path (Slow to Fast) For fastest shake set gobo timing to 0
			151 - 180	Gobo Twist Quickest Path (Slow to Fast) For fastest twist set gobo timing to 0
			181 - 210	Gobo Twist Normal Path (Slow to Fast) For fastest twist set gobo timing to 0
			211 - 255	Reserved Values

TABLE 1.16-BIT ENHANCED

DMX	PARAMETER	DEFAULTS	RANGE	DESCRIPTION
20	Gobo Wheel 2 (Fixed)	0	0-255	8-bit control of Gobo Wheel for movement options see channel 22 Single metal stamped wheel
			0-25	Open - No Gobo
			26-51	Gobo 1 (Leafy Breakup)
			52-77	Gobo 2 (Honeycomb)
			78-103	Gobo 3 (Radial Breakup)
			104-129	Gobo 4 (Grid)
			130-155	Gobo 5 (Circle of dots)
			156-181	Gobo 6 (Punchcard)
			182-207	Gobo 7 (Vertical bars)
			208-233	Gobo 8 (Medium Circle)
234 - 255	Open - No Gobo			
21	Gobo Wheel 2 Control	0	0 - 255	Used as a control channel for different movement options for Gobo Wheel 2 (Channel 21)
			0 - 5	Gobo Selection using shortest (quickest) path.
			6 - 10	Gobo Selection using normal (longest) path.
			11 - 20	Reserved Values
			21 - 50	Wheel Spin CW Forward (Fast to Slow)
			51 - 60	Wheel Spin STOP
			61 - 90	Wheel Spin CCW Reverse (Slow to Fast)
			91 - 120	Gobo Shake Quickest Path (Slow to Fast) For fastest shake set gobo timing to 0
			121 - 150	Gobo Shake Normal Path (Slow to Fast) For fastest shake set gobo timing to 0
			151 - 180	Reserved Values
			181 - 210	Reserved Values
211 - 255	Reserved Values			
22	Iris	0	0-255	Iris size control
			0 - 200	Iris beam size open to closed
			201 - 255	Iris pulse slow to fast
23	Frame 1A	0	0 - 255	Controls Framing Shutter 1A from Open to Full (DMX 0-255).
24	Frame 1B	0	0 - 255	Controls Framing Shutter 1B from Open to Full (DMX 0-255).
25	Frame 2A	0	0 - 255	Controls Framing Shutter 2A from Open to Full (DMX 0-255).
26	Frame 2B	0	0 - 255	Controls Framing Shutter 2B from Open to Full (DMX 0-255).
27	Frame 3A	0	0 - 255	Controls Framing Shutter 3A from Open to Full (DMX 0-255).
28	Frame 3B	0	0 - 255	Controls Framing Shutter 3B from Open to Full (DMX 0-255).
29	Frame 4A	0	0 - 255	Controls Framing Shutter 4A from Open to Full (DMX 0-255).
30	Frame 4B	0	0 - 255	Controls Framing Shutter 4B from Open to Full (DMX 0-255).
31	Frame Rotate	128	0 - 255	Controls Framing Shutter mechanism from +/- 90°
32	Triangular Prism	0 - 255	0 - 255	Controls Prism mechanism with following values.
			0 - 5	Open
			6 - 10	Index
			11 - 15	Rotate Normal
			16 - 20	Rotate with Mega Stepping
			21 - 255	Reserved Values

TABLE 1.16-BIT ENHANCED

DMX	PARAMETER	DEFAULTS	RANGE	DESCRIPTION
33	Prism Index/Rot High Byte	32767	0 - 65535	16-bit control of prism rotation and index.
34	Prism Index/Rot Low Byte		0 - 32756	Rotate Fast to Slow <<<
			32757 - 32780	Rotation STOP
			32781 - 65535	Rotate Slow to Fast >>>
35	Frost	0	0-255	Linear control of frost mechanism from out to full in (DMX 0-255)
36	Strobe Speed	128	0 - 255	Controls strobe rate from slowest (DMX 0) to fastest (DMX 255) 0.5Hz to 30Hz
37	Strobe Control	0	0 - 255	Control Channel for strobing functions. Set discrete value of desired effect
			0 - 5	Open
			6 - 10	Closed
			11 - 15	Normal Strobe
			16 - 20	Random Strobe
			21 - 25	Random Sync
			26 - 255	Reserved Values
38	Programmers Channel	0		Functions do not require 3 second DMX rule. mode will change once DMX level is reached
			0-40	Idle
			41 - 45	Dimming Curve Linear
			46 - 50	Dimming Curve S-Curve
			51 - 55	Dimming Curve Square Curve (Default)**
			56 - 60	Dimmer Snap On
			61 - 65	Dimmer Snap Off (Default)
			66 - 70	Reserved Values
			71 - 75	Reserved Values
			76 - 80	Edge Tracking on
			81 - 85	Edge tracking off (Default)
			86 - 90	Reserved Values
			91 - 95	Color Snap off (Default)
			96 - 100	Color Snap on (de-activates color timing channel)
			101 - 105	Reserved Values
			106 - 110	Reserved Values
			111 - 115	Reserved Values
			116 - 120	Reserved Values
			121 - 125	Reserved Values
			126 - 130	Reserved Values
			131 - 135	Reserved Values
136 - 140	Reserved Values			
141 - 145	Reserved Values			
146 - 150	Reserved Values			
151 - 155	Reserved Values			
156 - 160	Reserved Values			
161 - 165	Reserved Values			
166 - 170	Reserved Values			
171 - 175	Reserved Values			
176 - 255	Reserved Values			

TABLE 1.16-BIT ENHANCED

DMX	PARAMETER	DEFAULTS	RANGE	DESCRIPTION
39	Focus Timing	255	0 - 255	Adjustment of fixture timing to control Pan/Tilt mechanisms. See Timing Channel
40	Optics Timing	255	0 - 255	Adjustment of fixture timing to control lensing mechanisms. See Timing Channel
41	Color Timing	255	0 - 255	Adjustment of fixture timing to control color mechanisms. See Timing Channel
42	Beam Timing	255	0 - 255	Adjustment of fixture timing to control beam shaping mechanisms. See Timing Channel
43	Gobo Timing	255	0 - 255	Adjustment of fixture timing to control gobo mechanisms. See Timing Channel
44	Fan Control	0	0 - 255 0-4 05 - 255	Dynamically control fan speed vs LED Output operation. Control values as follows . . . Automatic fan/output adjustment (Default) Linear control of fan speed and LED max output* DMX 5 =Highest Constant Fan Speed (Standard mode) DMX 255 = Lowest Constant Fan Speed (Whisper mode) * Standard mode only function is dec-activated if Studio or Boost modes are selected via Dmx or User Interface

TABLE 1.16-BIT ENHANCED

DMX	PARAMETER	DEFAULTS	RANGE	DESCRIPTION
45	Luminaire Control	0	0 - 255	Control Channel used for full fixture settings lamp controls Set discrete value of desired effect then set value to 0 (Idle).
			0 - 5	Idle (Default)
			6 - 10	Full Luminaire ReCal - Also Used to Wake fixture up from shutdown
			11 - 15	Fixture Shutdown
			16 - 20	Reserved Values
			21 - 25	Display - Menu ON
			26 - 30	Display - Menu OFF
			31 - 35	Reserved Values
			36 - 40	Reserved Values
			41 - 45	Reserved Values
			46 - 50	Reserved Values
			51 - 55	Reserved Values
			56 - 60	Reserved Values
			61 - 65	Reserved Values
			66 - 70	Reserved Values
			71 - 75	Reserved Values
			76 - 80	Display On
			81 - 85	Display Off
			86 - 90	Status Check (Turn UI Screen Green if fixture has no Error - Red if Error)
			91 - 95	Reserved Values
			96 - 100	Reserved Values
			101 - 105	Reserved Values
			106 - 110	Boost Mode - Fixture output increase with Higher fan speed No Fan control (44)
111 - 115	Standard Mode			
116 - 120	Studio Mode - Reduced output with lower fan settings No Fan control (44)			
121 - 125	Reserved Values			
126 - 130	Reserved Values			
131 - 135	Reserved Values			
136 - 140	Fan On (Default) (Continuous spin rate)			
141 - 145	Fan Auto (Variable spin rate based on LED temperature)			
146 - 150	Reserved Values			
45	Luminaire Control <i>continued</i>	0	151 - 155	ReCal Position
			156 - 160	ReCal Color
			161 - 165	ReCal Beam
			166 - 170	ReCal Optics
			171-175	ReCal Gobo
			176 - 180	Reset fixture to default
			181 - 255	Reserved Values

TABLE 2. 16-BIT

DMX	PARAMETER	DEFAULTS	RANGE	DESCRIPTION
1	Intensity High	0	0-65535	16-bit control of Dimming
2	Intensity Low			
3	Pan High	32767	0-65535	540° Total Pan Rotation
4	Pan Low			
5	Tilt High	32767	0-65535	270° Total Tilt
6	Tilt Low			
7	Focus High	32767	0-65535	Focus control
8	Focus Low			Default value 50% Focus range
9	Zoom High	128	0-255	Zoom control Default value 50% zoom range
10	Cyan	0	0 - 255	Cyan Color Control 0-100% saturation
11	Yellow	0	0 - 255	Yellow Color Control 0-100% saturation
12	Magenta	0	0 - 255	Magenta Color Control 0-100% saturation
13	CTO	0	0 - 255	CTO Color correction Control 0-100% saturation
14	Color Wheel	0	0 - 255	8-bit control of Color Wheel (spin speed slow to fast from control channel) OPEN (centred at 0)
			0-31	Open
			32-63	VL RED Centre - 48
			64-95	Dark Blue Centre - 80
			96-127	Yellow Centre - 112
			128-159	Kelly Green Centre - 144
			160-191	Amber Centre 176
			192-223	Congo Blue Centre 208
224-255	Open			
15	Color Wheel Control	0	0 - 255	
			0 - 5	Linear Movement using shortest (quickest) path.
			6 - 10	Linear Movement using normal (longest) path.
			11 - 15	Wheel Spin CW (Forward)
			16 - 20	Wheel Spin STOP
			21 - 25	Wheel Spin CCW (Reverse)
			26 - 56	Color Shake Quickest Path (Slow to Fast) For fastest shake set color timing to 0
			57 - 87	Color Shake Normal Path (Slow to Fast) For fastest shake set color timing to 0
88 - 255	Reserved Values			

TABLE 2. 16-BIT

DMX	PARAMETER	DEFAULTS	RANGE	DESCRIPTION
16	Gobo Wheel 1	0	0 - 255	8-bit control of Gobo Wheel 1. See Channel 20 for control options. Interchangeable glass gobos
			0 - 5	Open - No Gobo
			6 - 10	Gobo 1 (Night Sky) Index
			11 - 15	Gobo 2 (Circle of Ovals) Index
			16 - 20	Gobo 3 (Bricked Out) Index
			21 - 25	Gobo 4 (Nurons) Index
			26 - 30	Gobo 5 (Swirl) Index
			31 - 35	Gobo 6 (Crossed-Bars) Index
			36 - 40	Gobo 7 (On the Rock) Index
			41 - 45	Open - No Gobo
			46 - 50	Gobo 1 (Night Sky) Rotate
			51 - 55	Gobo 2 (Circle of Ovals) Rotate
			56 - 60	Gobo 3 (Bricked Out) Rotate
			61 - 65	Gobo 4 (Nurons) Rotate
			66 - 70	Gobo 5 (Swirl) Rotate
			71 - 75	Gobo 6 (Crossed-Bars) Rotate
			76 - 80	Gobo 7 (On the Rock) Rotate
			81 - 85	Open - No Gobo
			86 - 90	Gobo 1 (Night Sky) Rotate with Mega Stepping
			91 - 95	Gobo 2 (Circle of Ovals) Rotate with Mega Stepping
96 - 100	Gobo 3 (Bricked Out) Rotate with Mega Stepping			
101 - 105	Gobo 4 (Nurons) Rotate with Mega Stepping			
106 - 110	Gobo 5 (Swirl) Rotate with Mega Stepping			
111 - 115	Gobo 6 (Crossed-Bars) Rotate with Mega Stepping			
116 - 120	Gobo 7 (On the Rock) Rotate with Mega Stepping			
121 - 255	Reserved Values			
17	Gobo 1 Rot/Index High Byte	32767	0 - 65535	16-bit control of index and rotation of gobo wheel 1.
			0 - 32756	Rotate Fast to Slow <<<
18	Gobo 1 Rot/Index Low Byte		32757 - 32780	Rotation STOP
			32781 - 65535	Rotate Slow to Fast >>>
19	Gobo Wheel 1 Control	0	0 - 255	Used as a control channel for different movement options for Gobo Wheel 1 (Channel 17)
			0 - 5	Gobo Selection using shortest (quickest) path.
			6 - 10	Gobo Selection using normal (longest) path.
			11 - 20	Reserved Values
			21 - 50	Wheel Spin CW Forward (Fast to Slow)
			51 - 60	Wheel Spin STOP
			61 - 90	Wheel Spin CCW Reverse (Slow to Fast)
			91 - 120	Gobo Shake Quickest Path (Slow to Fast) For fastest shake set gobo timing to 0
			121 - 150	Gobo Shake Normal Path (Slow to Fast) For fastest shake set gobo timing to 0
			151 - 180	Gobo Twist Quickest Path (Slow to Fast) For fastest twist set gobo timing to 0
			181 - 210	Gobo Twist Normal Path (Slow to Fast) For fastest twist set gobo timing to 0
			211 - 255	Reserved Values

TABLE 2. 16-BIT

DMX	PARAMETER	DEFAULTS	RANGE	DESCRIPTION
20	Gobo Wheel 2 (Fixed)	0	0-255	8-bit control of Gobo Wheel for movement options see channel 22; Single metal stamped wheel
			0-25	Open - No Gobo
			26-51	Gobo 1 (Leafy Breakup)
			52-77	Gobo 2 (Honeycomb)
			78-103	Gobo 3 (Radial Breakup)
			104-129	Gobo 4 (Grid)
			130-155	Gobo 5 (Circle of dots)
			156-181	Gobo 6 (Punchcard)
			182-207	Gobo 7 (Vertical bars)
			208-233	Gobo 8 (Medium Circle)
21	Gobo Wheel 2 Control	0	234 - 255	Open - No Gobo
			0 - 255	Used as a control channel for different movement options for Gobo Wheel 2 (Channel 21)
			0 - 5	Gobo Selection using shortest (quickest) path.
			6 - 10	Gobo Selection using normal (longest) path.
			11 - 20	Reserved Values
			21 - 50	Wheel Spin CW Forward (Fast to Slow)
			51 - 60	Wheel Spin STOP
			61 - 90	Wheel Spin CCW Reverse (Slow to Fast)
			91 - 120	Gobo Shake Quickest Path (Slow to Fast) For fastest shake set gobo timing to 0
			121 - 150	Gobo Shake Normal Path (Slow to Fast) For fastest shake set gobo timing to 0
			151 - 180	Reserved Values
181 - 210	Reserved Values			
211 - 255	Reserved Values			
22	Iris	0	0-255	Iris size control
			0 - 200	Iris beam size open to closed
			201 - 255	Iris pulse slow to fast
23	Frame 1A	0	0 - 255	Controls Framing Shutter 1A from Open to Full (DMX 0-255).
24	Frame 1B	0	0 - 255	Controls Framing Shutter 1B from Open to Full (DMX 0-255).
25	Frame 2A	0	0 - 255	Controls Framing Shutter 2A from Open to Full (DMX 0-255).
26	Frame 2B	0	0 - 255	Controls Framing Shutter 2B from Open to Full (DMX 0-255).
27	Frame 3A	0	0 - 255	Controls Framing Shutter 3A from Open to Full (DMX 0-255).
28	Frame 3B	0	0 - 255	Controls Framing Shutter 3B from Open to Full (DMX 0-255).
29	Frame 4A	0	0 - 255	Controls Framing Shutter 4A from Open to Full (DMX 0-255).
30	Frame 4B	0	0 - 255	Controls Framing Shutter 4B from Open to Full (DMX 0-255).
31	Frame Rotate	128	0 - 255	Controls Framing Shutter mechanism from +/- 90°
32	Triangular Prism	0 - 255	0 - 255	Controls Prism mechanism with following values.
			0 - 5	Open
			6 - 10	Index
			11 - 15	Rotate Normal
			16 - 20	Rotate with Mega Stepping
			21 - 255	Reserved Values

TABLE 2. 16-BIT

DMX	PARAMETER	DEFAULTS	RANGE	DESCRIPTION
33	Prism Index/Rot High Byte	32767	0 - 65535	16-bit control of prism rotation and index.
			0 - 32756	Rotate Fast to Slow <<<
34	Prism Index/Rot Low Byte		32757 - 32780	Rotation STOP
			32781 - 65535	Rotate Slow to Fast >>>
35	Frost	0	0-255	Linear control of frost mechanism from out to full in (DMX 0- 255)
36	Strobe Speed	128	0 - 255	Controls strobe rate from slowest to fastest (DMX 0-255) 0.5Hz to 30Hz
37	Strobe Control	0	0 - 255	Control Channel for strobing functions. Set discrete value of desired effect
			0 - 5	Open
			6 - 10	Closed
			11 - 15	Normal Strobe
			16 - 20	Random Strobe
			21 - 25	Random Sync
			26 - 255	Reserved Values
38	Programmers Channel	0	0-40	Functions do not require 3 second DMX rule. mode will change once DMX level is reached Idle
			41 - 45	Dimming Curve Linear
			46 - 50	Dimming Curve S-Curve
			51 - 55	Dimming Curve Square Curve (Default)**
			56 - 60	Dimmer Snap On
			61 - 65	Dimmer Snap Off (Default)
			66 - 70	Reserved Values
			71 - 75	Reserved Values
			76 - 80	Edge Tracking on
			81 - 85	Edge tracking off (Default)
			86 - 90	Reserved Values
			91 - 95	Color Snap off (Default)
			96 - 100	Color Snap on (de-activates color timing channel)
			101 - 105	Reserved Values
			106 - 110	Reserved Values
			111 - 115	Reserved Values
			116 - 120	Reserved Values
			121 - 125	Reserved Values
			126 - 130	Reserved Values
			131 - 135	Reserved Values
			136 - 140	Reserved Values
			141 - 145	Reserved Values
			146 - 150	Reserved Values
			151 - 155	Reserved Values
			156 - 160	Reserved Values
			161 - 165	Reserved Values
			166 - 170	Reserved Values
			171 - 175	Reserved Values
			176 - 255	Reserved Values

TABLE 2. 16-BIT

DMX	PARAMETER	DEFAULTS	RANGE	DESCRIPTION
39	Fan Control	0	0 - 255	Dynamically control fan speed vs LED Output operation. Control values as follows . . .
			0-4	Automatic fan/output adjustment (Default)
			05 - 255	Linear control of fan speed and LED max output* DMX 5 =Highest Constant Fan Speed (Standard mode) DMX 255 = Lowest Constant Fan Speed (Whisper mode) * Standard mode only function is dec-activated if Studio or Boost modes are selected via Dmx or User Interface

TABLE 2. 16-BIT

DMX	PARAMETER	DEFAULTS	RANGE	DESCRIPTION
40	Luminaire Control	0	0 - 255	Control Channel used for full fixture settings lamp controls. Set discrete value of desired effect then set value to 0 (Idle).
			0 - 5	Idle (Default)
			6 - 10	Full Luminaire ReCal - Also Used to Wake fixture up from shutdown
			11 - 15	Fixture Shutdown
			16 - 20	Reserved Values
			21 - 25	Display - Menu ON
			26 - 30	Display - Menu OFF
			31 - 35	Reserved Values
			36 - 40	Reserved Values
			41 - 45	Reserved Values
			46 - 50	Reserved Values
			51 - 55	Reserved Values
			56 - 60	Reserved Values
			61 - 65	Reserved Values
			66 - 70	Reserved Values
			71 - 75	Reserved Values
			76 - 80	Display On
			81 - 85	Display Off
			86 - 90	Status Check (Turn UI Screen Green if fixture has no Error - Red if Error)
			91 - 95	Reserved Values
			96 - 100	Reserved Values
			101 - 105	Reserved Values
			106 - 110	Boost Mode - Fixture output increase with Higher fan speed No Fan control (44)
			111 - 115	Standard Mode -
			116 - 120	Studio Mode - Reduced output with lower fan settings No Fan control (44)
			121 - 125	Reserved Values
			126 - 130	Reserved Values
			131 - 135	Reserved Values
			136 - 140	Fan On (Default) (Continuous spin rate)
			141 - 145	Fan Auto (Variable spin rate based on LED temperature)
146 - 150	Reserved Values			
151 - 155	ReCal Position			
156 - 160	ReCal Color			
161 - 165	ReCal Beam			
166 - 170	ReCal Optics			
171-175	ReCal Gobo			
176 - 180	Reset fixture to default			
181 - 255	Reserved Values			

TABLE 3. CLONE

DMX	PARAMETER	DEFAULTS	RANGE	DESCRIPTION
1	Intensity High	0	0-65535	16-bit control of Dimming
2	Intensity Low			
3	Pan High	32767	0-65535	540° Total Pan Rotation
4	Pan Low			
5	Tilt High	32767	0-65535	270° Total Tilt
6	Tilt Low			
7	Focus High	32767	0-65535	Focus control Default value 50% Focus range
8	Focus Low			
9	Zoom High	128	0-255	Zoom control Default value 50% zoom range
10	Cyan	0	0 - 255	Cyan Color Control 0-100% saturation
11	Yellow	0	0 - 255	Yellow Color Control 0-100% saturation
12	Magenta	0	0 - 255	Magenta Color Control 0-100% saturation
13	CTO	0	0 - 255	CTO Color correction Control 0-100% saturation
14	Color Wheel	0	0 - 255	Color Wheel.
			0-5	Open
			6-11	Centered Color VL RED Center-9
			12-17	Centered Color Dark Blue Center-15
			18-23	Centered Color Yellow Center-21
			24-29	Centered Color Kelly Green Center-27
			30-35	Centered Color Amber Center-33
			36-41	Centered Color Congo Blue Center-39
			42-47	Variable position Open Center-45
			48-68	Variable position VL RED Center-58
			69-89	Variable position Dark Blue Center-79
			90-110	Variable position Yellow Center-100
			111-131	Variable position Kelly Green Center-121
			132-152	Variable position Amber Center-142
153-173	Variable position Congo Blue Center-163			
174-179	Variable position Open Center-177			
180-211	Variable position Color Rotate Clockwise S>>>>>>>F Center-196			
212-217	Variable position Stop no Rotation Center-215			
218-249	Variable position Color Rotate Counter Clockwise S<<<<<<<<F Center-234			
250-255	Variable position Open Center-253			

TABLE 3. CLONE

DMX	PARAMETER	DEFAULTS	RANGE	DESCRIPTION
15	Gobo Wheel 1	0		8-bit control of Gobo Wheel 1. See Channel 20 for control options. Index
			0-3	Open - No Gobo
			4-7	Gobo 1 (Night Sky) Index
			8-11	Gobo 2 (Circle of Ovals) Index
			12-15	Gobo 3 (Bricked Out) Index
			16-19	Gobo 4 (Nurons) Index
			20-23	Gobo 5 (Swirl) Index
			24-27	Gobo 6 (Crossed Bars) Index
			28-31	Gobo 7 (On the Rock) Index
			32-35	Open - No Gobo
			36-39	Gobo 1 (Night Sky) Rotate
40-43	Gobo 2 (Circle of Ovals) Rotate			
15	Gobo Wheel 1 <i>continued</i>	0	44-47	Gobo 3 (Bricked Out) Rotate
			48-51	Gobo 4 (Nurons) Rotate
			52-55	Gobo 5 (Swirl) Rotate
			56-59	Gobo 6 (Crossed Bars) Rotate
			60-63	Gobo 7 (On the Rock) Rotate
			64-67	Open - No Gobo
			68-71	Gobo 1 (Night Sky) Rotate with Mega Stepping
			72-75	Gobo 2 (Circle of Ovals) Rotate with Mega Stepping
			76-79	Gobo 3 (Bricked Out) Rotate with Mega Stepping
			80-83	Gobo 4 (Nurons) Rotate with Mega Stepping
			84-87	Gobo 5 (Swirl) Rotate with Mega Stepping
			88-91	Gobo 6 (Crossed Bars) Rotate with Mega Stepping
			92-95	Gobo 7 (On the Rock) Rotate with Mega Stepping
			96-99	Open - No Gobo
			100-121	Gobo 1 (Night Sky) Rotate with Twist Slow >>>> Fast
			122-142	Gobo 2 (Circle of Ovals) Rotate with Twist Slow >>>> Fast
			143-163	Gobo 3 (Bricked Out) Rotate with Twist Slow >>>> Fast
164-184	Gobo 4 (Nurons) Rotate with Twist Slow >>>> Fast			
185-205	Gobo 5 (Swirl) Rotate with Twist Slow >>>> Fast			
206-226	Gobo 6 (Crossed Bars) Rotate with Twist Slow >>>> Fast			
227-247	Gobo 7 (On the Rock) Rotate with Twist Slow >>>> Fast			
248-255	Open - No Gobo			
16	Gobo 1 Rot/Index High Byte	32767	0 - 65535	16-bit control of index and rotation of gobo wheel 1.
			0 - 32756	Rotate Fast to Slow <<<
17	Gobo 1 Rot/Index Low Byte		32757 - 32780	Rotation STOP
			32781 - 65535	Rotate Slow to Fast >>>

TABLE 3. CLONE

DMX	PARAMETER	DEFAULTS	RANGE	DESCRIPTION
18	Gobo Wheel 2 (Fixed)	0	0-255	8-bit control of Gobo Wheel for movement options see channel 22
			0	Open - No Gobo
			1	Gobo 1 (Leafy Breakup)
			2	Gobo 2 (Honeycomb)
			3	Gobo 3 (Radial Breakup)
			4	Gobo 4 (Grid)
			5	Gobo 5 (Circle of dots)
			6	Gobo 6 (Punchcard)
			7	Gobo 7 (Vertical Bars)
			8	Gobo 8 (Medium Circle)
			9	Open - No Gobo
			10 - 13	Gobo 1 (Leafy Breakup) Shake Fast >>>> Slow
			14 - 34	Gobo 2 (Honeycomb) Shake Fast >>>> Slow
			35 - 55	Gobo 3 (Radial Breakup) Shake Fast >>>> Slow
			56 - 76	Gobo 4 (Grid) Shake Fast >>>> Slow
			77 - 97	Gobo 5 (Circle of dots) Shake Fast >>>> Slow
			98 - 118	Gobo 6 (Punchcard) Shake Fast >>>> Slow
119 - 139	Gobo 7 (Vertical bars) Shake Fast >>>> Slow			
140 - 160	Gobo 8 (Medium Circle) Shake Fast >>>> Slow			
161-185	Open - No Gobo			
186 - 216	Gobo Wheel Rotate Clockwise S>>>>F			
18	Gobo Wheel 2 (Fixed) <i>continued</i>	0	217-220	Stop No Rotation
			221-251	Gobo Wheel Rotate Counter Clockwise S>>>>F
			252-255	Stop No Rotation
19	Iris	0	0-255	Iris size control
			0 - 200	Iris beam size open to closed
			201 - 255	Iris pulse slow to fast
20	Frame 1A	0	0 - 255	Controls Framing Shutter 1A from Open to Full (DMX 0-255).
21	Frame 1B	0	0 - 255	Controls Framing Shutter 1B from Open to Full (DMX 0-255).
22	Frame 2A	0	0 - 255	Controls Framing Shutter 2A from Open to Full (DMX 0-255).
23	Frame 2B	0	0 - 255	Controls Framing Shutter 2B from Open to Full (DMX 0-255).
24	Frame 3A	0	0 - 255	Controls Framing Shutter 3A from Open to Full (DMX 0-255).
25	Frame 3B	0	0 - 255	Controls Framing Shutter 3B from Open to Full (DMX 0-255).
26	Frame 4A	0	0 - 255	Controls Framing Shutter 4A from Open to Full (DMX 0-255).
27	Frame 4B	0	0 - 255	Controls Framing Shutter 4B from Open to Full (DMX 0-255).
28	Frame Rotate	128	0 - 255	Controls Framing Shutter mechanism from +/- 90°
29	Triangular Prism	0 - 255	0 - 255	Controls Prism mechanism with following values.
			0 - 5	Open
			6 - 10	Index
			11 - 15	Rotate Normal
			16 - 20	Rotate with Mega Stepping
21 - 255	Reserved Values			
30	Prism Index/Rot High Byte	32767	0 - 65535	16-bit control of prism rotation and index.
			0 - 32756	Rotate Fast to Slow <<<
31	Prism Index/Rot Low Byte		32757 - 32780	Rotation STOP
			32781 - 65535	Rotate Slow to Fast >>>

TABLE 3. CLONE

DMX	PARAMETER	DEFAULTS	RANGE	DESCRIPTION
32	Frost	0	0-255	Linear control of frost mechanism from out (DMX 0) to full in (DMX 255)
33	Strobe / Shutter	33	0 - 5 6 - 11 12 - 87 88 - 93 94 - 169 170 - 245 246 - 251 252 - 255	Shutter Closed Shutter Open (Default 33) Strobe Slow>>>>>>>Fast Strobe Open Strobe Random Slow>>>>>>>Fast Strobe Random Sync Slow>>>>>>>Fast Shutter Open Reserved
34	Programmers Channel	0	0-40 41 - 45 46 - 50 51 - 55 56 - 60 61 - 65	Functions do not require 3 second DMX rule. mode will change once DMX level is reached Idle Dimming Curve Linear Dimming Curve S-Curve Dimming Curve Square Curve (Default)** Reserved Values Dimmer Snap On
34	Programmers Channel <i>continued</i>	0	66 - 70 71 - 75 76 - 80 81 - 85 86 - 90 91 - 95 96 - 100 101 - 105 106 - 110 111 - 115 116 - 120 121 - 125 126 - 130 131 - 135 136 - 140 141 - 145 146 - 150 151 - 155 156 - 160 161 - 165 166 - 170 171 - 175 176 - 255	Dimmer Snap Off (Default) Reserved Values Edge Tracking on Edge tracking off (Default Reserved Values Color Snap off (Default) Color Snap on (de-activates color timing channel) Reserved Values Reserved Values Reserved Values Reserved Values Reserved Values Reserved Values Reserved Values Reserved Values Reserved Values Reserved Values Reserved Values Reserved Values Reserved Values Reserved Values Reserved Values Reserved Values Reserved Values Reserved Values

TABLE 3. CLONE

DMX	PARAMETER	DEFAULTS	RANGE	DESCRIPTION
35	Luminaire Control	0	0 - 255	Control Channel used for full fixture settings lamp controls. Set discrete value of desired effect then set value to 0 (Idle).
			0 - 5	Idle (Default)
			6 - 10	Full Luminaire ReCal - Also Used to Wake fixture up from shutdown
			11 - 15	Fixture Shutdown
			16 - 20	Reserved Values
			21 - 25	Display - Menu ON
			26 - 30	Display - Menu OFF
			31 - 35	Reserved Values
			36 - 40	Reserved Values
			41 - 45	Reserved Values
			46 - 50	Reserved Values
			51 - 55	Reserved Values
			56 - 60	Reserved Values
			61 - 65	Reserved Values
			66 - 70	Reserved Values
			71 - 75	Reserved Values
			76 - 80	Display On
			81 - 85	Display Off
86 - 90	Status Check (Turn UI Screen Green if fixture has no Error - Red if Error)			
91 - 95	Reserved Values			
96 - 100	Reserved Values			
101 - 105	Reserved Values			
106 - 110	Boost Mode - Fixture output increase with Higher fan speed			

4 OPERATION

A DMX termination connector is used in this process. Solder a 120 Ω 1/4W resistor between pin 2 (DMX-) and pin 3 (DMX+) into a 5-pin XLR-plug and plug it in the DMX-output of the last unit. A maximum of 32 luminaires can be connected to one DMX512 data link.

Connect the unit together in a "daisy chain" by XLR plug from the output of the unit to the input of the next unit. The cable can not branched or split to a "Y" cable. DMX 512 is a very high-speed signal. Inadequate or damaged cables, soldered joints or corroded connectors can easily distort the signal and shut down the system. The DMX output and input connectors are pass-through to maintain the DMX circuit, when one of the units' power is disconnected.

Each lighting unit needs to have an address set to receive the data sent by the controller. The address number is between 0-511 (usually 0 & 1 are equal to 1).

The end of the DMX 512 system should be terminated to reduce signal errors.

5 pin XLR: Pin 1: GND, Pin 2: Negative signal (-), Pin 3: Positive signal (+), Pin 4/Pin 5: Not used.

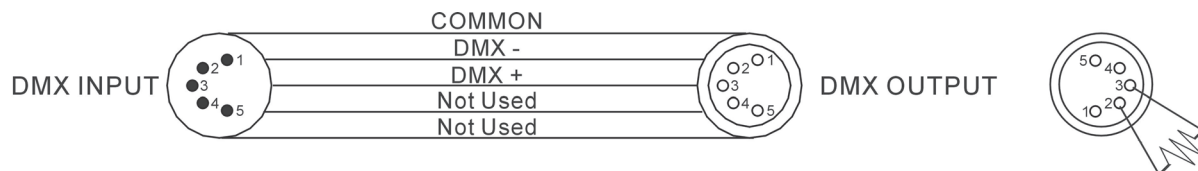
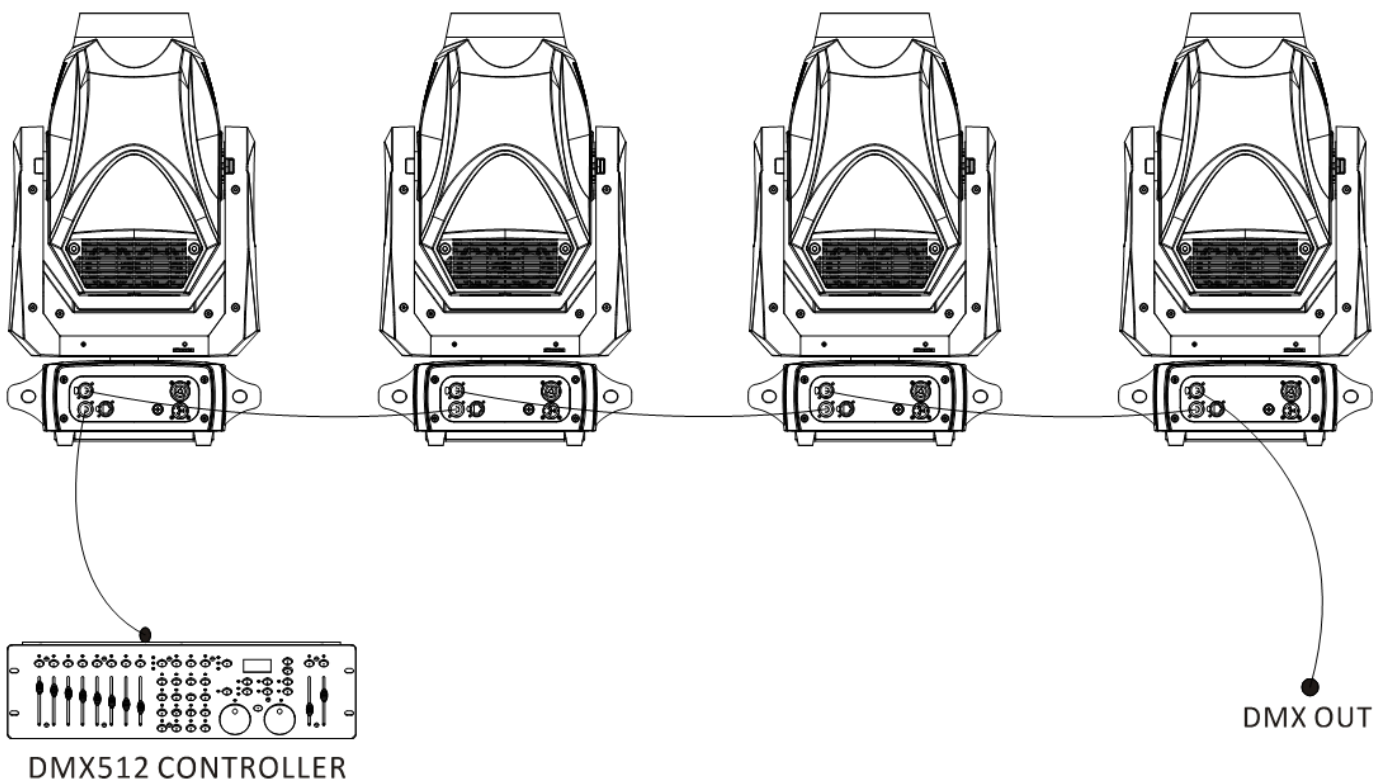

MENU OPERATION

WHAT IS THE MENU SYSTEM?

The menu system is a programmable set of commands used to configure, address, operate, and test the luminaire. The menu system is controlled at the Menu Display available at the enclosure input panel.

CONTROLS OPERATION

The menu system is controlled by [MENU], [ENTER], and four ▲▼ arrow buttons.

The arrows have opposite functions if the luminaire is hung upside down in a hanging orientation due to the automatic orientation feature. In other words, the arrow pointing downward always functions as down/decrease and the arrow pointing upward always functions as up/increase regardless of the luminaire orientation.

DEFAULT STATE

The menu display's default state during normal operation is to display the DMX address. After 40 seconds of inactivity at the display, it will change to the default state.

After longer periods of inactivity, the menu display will switch to its off state. The default state for this feature is 30 seconds, however, different time lengths can also be programmed.

To program a different time length for menu off feature:

- Step 1. Press [ESC] access the main menu.
- Step 2. Once enabled, the menu will function as normal with only the following sub-menu sections active:
 - Address
 - Configure
 - DMX
 - Fixture
 - Manual Control
 - Test
- Step 3. Press ▲▼ choose the "Configure", and press [ENTER].
- Step 4. Press ▲▼ choose the "Display", and press [ENTER].
- Step 5. Press ▲▼ choose the "On Time", and press [ENTER].
- Step 6. Press ▲▼ choose "30 Sec", "5 Min", "10 Min", "On" when you need.

MENU FUNCTIONS

For easy reference, each possible menu item is listed alphabetically in the first column by its display abbreviation. The second column follows with a definition of the abbreviation and then a third column provides an explanation of its purpose and function.

To select any functions, press the MENU button until the required one is shown on the display. Select the function by the ENTER button and the display will blink. Use the DOWN and UP button to change the mode. Once the required mode has been selected, press the ENTER button to setup or it will automatically return to the main functions without any change after idling one minute. Back to the functions without any change press the MENU button.

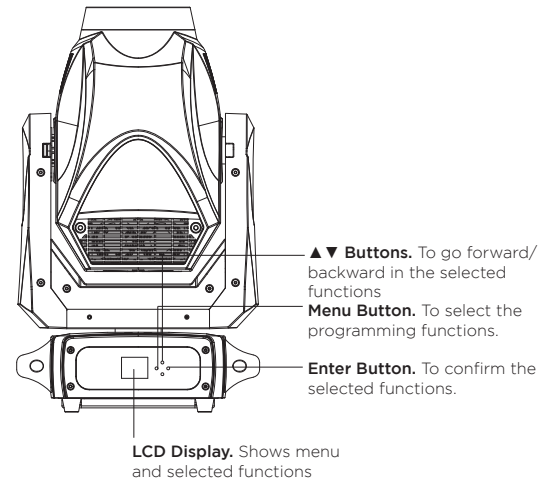

TABLE 7. MENU SYSTEM

LEVEL 1	LEVEL 2	LEVEL 3	LEVEL 4	LEVEL 5	LEVEL 6	DEFAULT
ADDRESS	001-512					(Default 001)
CONFIGURE	LED	LED Hours	XXXXXX h			
		Reset LED Hour	Are you sure?			
		Dimming Curve	Square Law			(Default)
			S Curve			
			Linear			
		Dim Snap	Snap On			
			Snap Off			(Default)
		Output Mode	Boost			
			Standard			(Default)
			Studio			
		Fan Mode	On			(Default)
			Auto			
		Refresh rate	900Hz			
			910Hz			
			920Hz			
	930Hz					
	940Hz					
	950Hz					
	960Hz					
	980Hz					
	990Hz					
	1000Hz					
	1500Hz				(Default)	
	2500Hz					
	4000Hz					
	Movement	Pan Motor	Enable			(Default)
			Disable			
		Tilt Motor	Enable			(Default)
			Disable			
	Display	Miss Orientation?	Up			(Default)
			Down			
		On Time	30 Sec			(Default)
			5 Min			
10 Min						
Focus Compensate	Disable					
	5M					
	10M			(Default)		
	15M					
Reset Defaults	Are you sure?					

TABLE 7. MENU SYSTEM

LEVEL 1	LEVEL 2	LEVEL 3	LEVEL 4	LEVEL 5	LEVEL 6	DEFAULT	
DMX	Address	001-512					
	DMX Mode	16-bit Enh					(Default)
		16-bit					
		Clone Mode					
	Select Signal	DMX Only					(Default)
		Art-Net			On		
			Off		(Default)		
	Set Artnet	Set Universe		0-15			
		Net		0-127			
		Sub-Net		0-15			
		Ethernet IP		XXX. XXX. XXX. XXX			
		Ethernet Mask IP		XXX. XXX. XXX. XXX			
	DMX Fail/No DMX	Hold					(Default)
		Fade to blackout					
		Goto Preset		1 to 20			
	Pan/Tilt	Swap Pan/Tilt			Off		(Default)
					On		
		Invert Pan			Off		(Default)
					On		
		Invert Tilt			Off		(Default)
			On				
	Data	Ch 1 - Intensity XXX (Value)					
		Ch 2 - Intensity Fine XXX (Value)					
.....All functions							

TABLE 7. MENU SYSTEM

LEVEL 1	LEVEL 2	LEVEL 3	LEVEL 4	LEVEL 5	LEVEL 6	DEFAULT	
FIXTURE	Status	(No Errors... or displays a list of errors)					
	Recal (Fixture)	Are you sure?					
	Reboot Fixture	Are you sure?					
	Version	VXXX			MM/D/YY	HH:MM	
	Fixture Hours	XXXXXX h					
	Cross load (Software)	Send					
		Service	Service Settings	Password access only (2606)	Set Position Cal	Pan	(-128-127)
						Tilt	(-128-127)
						Re. Pos. Offset	No/Yes
						ReCal Position	No/Yes
					Color Offset	Cyan	(-128-127)
						Yellow	(-128-127)
						Magenta	(-128-127)
						CTO	(-128-127)
						Color Wheel	(-128-127)
						Reset Color Offset	No/Yes
					Gobo Offset	ReCal Color	No/Yes
						Gobo1 Wheel	No/Yes
						Gobo1 Rot	(-128-127)
						Gobo2 Wheel	(-128-127)
						Reset Gobo Offset	No/Yes
					Optics Offset	ReCal Gobo	No/Yes
						Focus	(-128-127)
						Zoom	(-128-127)
						Prism	(-128-127)
						Prism Rot	(-128-127)
						Frost	(0-255)
						Re. Opt. Offset	No/Yes
					Beam Offset	ReCal Optics	No/Yes
						Iris	(0-255)
						Frame Rot	(-128-127)
						Frame 1A	(0-255)
	Frame 1B					(0-255)	
	Frame 2A					(0-255)	
	Frame 2B					(0-255)	
	Frame 3A					(0-255)	
	Frame 3B					(0-255)	
	Frame 4A					(0-255)	
	Frame 4B	(0-255)					
	Re. Opt. Offset	No/Yes					
	ReCal Frame	No/Yes					
	Diagnostics	Fan Check					
		LED Temp					

TABLE 7. MENU SYSTEM

LEVEL 1	LEVEL 2	LEVEL 3	LEVEL 4	LEVEL 5	LEVEL 6	DEFAULT	
TEST	All Test	(Run 'ALL TEST')					
	Pan/Tilt Test	(Run 'PAN/TILT TEST')					
	Test Channel	Intensity				(Run Intensity test)	
		Pan				(Run Pan test)	
	All functions				
	Encoder Pan	XXXXXXXX - Displays Pan Encoder					
Encoder Tilt	XXXXXXXX - Displays Tilt Encoder						
MANUAL/ PRESET	Preset Playback	Select preset			1 to 20		
		Intensity			0 - 255		
	User Preset Setting	Intensity			0 - 255		
		Shutter / Strobe			0 - 255		
		Pan			0 - 255		
		Tilt			0 - 255		
		Cyan			0 - 255		
		Yellow			0 - 255		
		Magenta			0 - 255		
		CTO			0 - 255		
		Color Wheel			0 - 255		
		Gobo 1			0 - 255		
		Gobo 2			0 - 255		
		Prism			0 - 255		
		Zoom			0 - 255		
		Focus			0 - 255		
		Iris			0 - 255		
		Frost			0 - 255		
		Frame 1A			0 - 255		
		Frame 1B			0 - 255		
		Frame 2A			0 - 255		
		Frame 2B			0 - 255		
		Frame 3A			0 - 255		
		Frame 3B			0 - 255		
		Frame 4A			0 - 255		
		Frame 4B			0 - 255		
		Frame Rotate			0 - 255		
		Store	1 >>>>>>>>>>	20			Are your sure (Yes/No)
		Clear	1 >>>>>>>>>>	20			Are your sure (Yes/No)

ADDRESS

To select Address, press the ENTER button to confirm. Use the UP/DOWN button to adjust the address from 001 to 512, press the ENTER button to store. Press the MENU button back to the last menu or let the unit idle one minute to exit menu mode.

CONFIGURE

To select Configure, press the ENTER button to confirm, use the UP/DOWN button to select LED, Movement, Display, Focus Compensate or Reset Defaults.

LED

To select LED, press the ENTER button to confirm. Use the UP/DOWN button to select LED Hours, Reset LED Hour, Dimming Curve, Dim Snap, Output Mode, Fan Mode or Refresh Rate, press the ENTER button to store. Press the MENU button back to the last menu or let the unit idle one minute to exit menu mode.

LED Hours

Select LED Hours, press the ENTER button to confirm, LED Hours will show on the display, press the MENU button back to exit.

Reset LED Hour

Select Reset LED Hour, press the ENTER button to confirm, Are you sure? will show on the display, press the ENTER button to store. Press the MENU button back to the last menu or let the unit idle one minute to exit menu mode.

Dimming Curve

To select Dimming Curve, press the ENTER button to confirm. Use the UP/DOWN button to select Square Law, S Curve or Linear, press the ENTER button to store. Press the MENU button back to the last menu or let the unit idle one minute to exit menu mode.

Dim Snap

To select Dim Snap, press the ENTER button to confirm. Use the UP/DOWN button to select Snap On or Snap Off, press the ENTER button to store. Press the MENU button back to the last menu or let the unit idle one minute to exit menu mode.

Output Mode

To select Output Mode, press the ENTER button to confirm. Use the UP/DOWN button to select Boost, Standard or Studio, press the ENTER button to store. Press the MENU button back to the last menu or let the unit idle one minute to exit menu mode.

Fan Mode

To select Fan Mode, press the ENTER button to confirm. Use the UP/DOWN button to select On or Auto, press the ENTER button to store. Press the MENU button back to the last menu or let the unit idle one minute to exit menu mode.

Refresh Rate

To select Refresh Rate, press the ENTER button to confirm. Use the UP/DOWN button to select 900Hz, 910Hz, 920Hz, 930Hz, 940Hz, 950Hz, 960Hz, 980Hz, 990Hz, 1000Hz, 1500Hz, 2500Hz or 4000Hz, press the ENTER button to store. Press the MENU button back to the last menu or let the unit idle one minute to exit menu mode.

Movement

To select Movement, press the ENTER button to confirm. Use the UP/DOWN button to select Pan Motor or Tilt Motor, press the ENTER button to store. Press the MENU button back to the last menu or let the unit idle one minute to exit menu mode.

Pan Motor

To select Pan Motor, press the ENTER button to confirm. Use the UP/DOWN button to select Enable or Disable, press the ENTER button to store. Press the MENU button back to the last menu or let the unit idle one minute to exit menu mode.

Tilt Motor

To select Tilt Motor, press the ENTER button to confirm. Use the UP/DOWN button to select Enable or Disable, press the ENTER button to store. Press the MENU button back to the last menu or let the unit idle one minute to exit menu mode.

Display

Select Display, press the ENTER button to confirm. Use the UP/DOWN button to select Miss Orientation? or On Time, press the ENTER button to store. Press the MENU button back to the last menu or let the unit idle one minute to exit menu mode.

Miss Orientation?

Select Miss Orientation?, press the ENTER button to confirm, Use the UP/DOWN button to select Up or Down, press the ENTER button to store. Press the MENU button back to the last menu or let the unit idle one minute to exit menu mode.

On Time

Select On Time, press the ENTER button to confirm, Use the UP/DOWN button to select 30 Sec, 5 Min, 10 Min or On, press the ENTER button to store. Press the MENU button back to the last menu or let the unit idle one minute to exit menu mode.

Focus Compensate

Select Focus Compensate, press the ENTER button to confirm, Use the UP/DOWN button to select Disable, 5M, 10M or 15M, press the ENTER button to store. Press the MENU button back to the last menu or let the unit idle one minute to exit menu mode.

Reset Defaults

Select Reset Defaults, press the ENTER button to confirm, Are you sure? will show on the display, press the ENTER button to store. Press the MENU button back to the last menu or let the unit idle one minute to exit menu mode.

DMX

To select DMX, press the ENTER button to confirm, use the UP/DOWN button to select Address, DMX Mode, Select Signal, Set Artnet, DMX Fail/No DMX, Pan/Tilt or Data.

Address

To select Address, press the ENTER button to confirm. Use the UP/DOWN button to adjust the address from 001 to 512, press the ENTER button to store. Press the MENU button back to the last menu or let the unit idle one minute to exit menu mode.

DMX Mode

To select DMX Mode, press the ENTER button to confirm. Use the UP/DOWN button to select 16-bit Enh, 16-bit or Clone Mode, press the ENTER button to store. Press the MENU button back to the last menu or let the unit idle one minute to exit menu mode.

Select Signal

To select Select Signal, press the ENTER button to confirm. Use the UP/DOWN button to select DMX Only or Art-Net, press the ENTER button to store. Press the MENU button back to the last menu or let the unit idle one minute to exit menu mode.

Art-Net

To select Art-Net, press the ENTER button to confirm. Use the UP/DOWN button to select On or Off, press the ENTER button to store. Press the MENU button back to the last menu or let the unit idle one minute to exit menu mode.

Set Artnet

To select Set Artnet, press the ENTER button to confirm. Use the UP/DOWN button to select Set Universe, Net, Sub-Net, Ethernet IP or Ether Mask IP, press the ENTER button to store. Press the MENU button back to the last menu or let the unit idle one minute to exit menu mode.

DMX Fail / No DMX

To select DMX Fail / No DMX press the ENTER button to confirm. Use the UP/DOWN button to select Hold, Fade to blackout or Goto Preset, press the ENTER button to store. Press the MENU button back to the last menu or let the unit idle one minute to exit menu mode.

Pan/Tilt

To select Pan/Tilt, press the ENTER button to confirm. Use the UP/DOWN button to select Swap Pan/Tilt, Invert Pan or Invert Tilt, press the ENTER button to store. Use the UP/DOWN button to select Off or On, press the ENTER button to store. Press the MENU button back to the last menu or let the unit idle one minute to exit menu mode.

Data

To select Data, press the ENTER button to confirm. Use the UP/DOWN button to select Ch1-Intensity, Ch2-Intensity Fine orAll functions, press the ENTER button to store. Press the MENU button back to the last menu or let the unit idle one minute to exit menu mode.

FIXTURE

To select Fixture, press the ENTER button to confirm, use the UP/DOWN button to select Status, ReCal (Fixture), Reboot Fixture, Version, Fixture Hours, Cross load (Software) or Service.

Status

Select Status, press the ENTER button to confirm, (No Errors... or displays a list of errors) will show on the display, press the MENU button back to exit.

Recal (Fixture)

Select Recal (Fixture), press the ENTER button to confirm, Are you sure? will show on the display, press the ENTER button to store. Press the MENU button back to the last menu or let the unit idle one minute to exit menu mode.

Reboot Fixture

Select Reboot Fixture, press the ENTER button to confirm, Are you sure? will show on the display, press the ENTER button to store. Press the MENU button back to the last menu or let the unit idle one minute to exit menu mode.

Version

Select Version, press the ENTER button to confirm, version will show on the display, press the MENU button back to exit.

Fixture Hours

Select Fixture Hours, press the ENTER button to confirm, fixture hours will show on the display, press the MENU button back to exit.

Cross load (Software)

Select Cross load (Software), press the ENTER button to confirm, Send will show on the display, press the ENTER button to store. Press the MENU button back to the last menu or let the unit idle one minute to exit menu mode.

Service

To select Service, press the ENTER button to confirm. Use the UP/DOWN button to select Service Settings or Diagnostics, press the ENTER button to store. Press the MENU button back to the last menu or let the unit idle one minute to exit menu mode.

Service Settings

Select Service Settings, press the ENTER button to go into Password access only, press ENTER to key password 2606 to confirm. Use the UP/DOWN button to select Set Position Cal, Color Offset, Gobo Offset, Optics Offset or Beam Offset, press the ENTER button to store. Press the MENU button back to the last menu or let the unit idle one minute to exit menu mode.

Set Position Cal

Select Set Position Cal press the ENTER button to confirm. Use the UP/DOWN button to select Pan, Tilt, Re. Pos. Offset or ReCal Position, then use the UP/DOWN button to adjust the value for Pan or Tilt, press the ENTER button to store, the fixture will run as the channel value indicates and to select No or Yes for Re. Pos. Offset or ReCal Position. Press the MENU button back to the last menu or exit menu mode idling one minute.

Color Offset

Select Color Offset press the ENTER button to confirm. Use the UP/DOWN button to select Cyan, Yellow, Magenta, CTO, Color Wheel, Reset Color Offset or ReCal Color, then use the UP/DOWN button to adjust the value for Cyan, Yellow, Magenta, CTO or Color Wheel, press the ENTER button to store, the fixture will run as the channel value indicates and to select No or Yes for Reset Color Offset or ReCal Color. Press the MENU button back to the last menu or exit menu mode idling one minute.

Gobo Offset

Select Gobo Offset press the ENTER button to confirm. Use the UP/DOWN button to select Gobo 1 Wheel, Gobo 1 Rot, Gobo2 Wheel, Reset Gobo Offset or ReCal Gobo, then use the UP/DOWN button to adjust the value for Gobo 1 Wheel, Gobo 1 Rot or Gobo2 Wheel, press the ENTER button to store, the fixture will run as the channel value indicates and to select No or Yes for Reset Gobo Offset or ReCal Gobo. Press the MENU button back to the last menu or exit menu mode idling one minute.

Optics Offset

Select Optics Offset press the ENTER button to confirm. Use the UP/DOWN button to select Focus, Zoom, Prism, Prism Rot, Frost, Re. Opt. Offset or ReCal Optics, then use the UP/DOWN button to adjust the value for Focus, Zoom, Prism, Prism Rot or Frost, press the ENTER button to store, the fixture will run as the channel value indicates and to select No or Yes for Re. Opt. Offset or ReCal Optics. Press the MENU button back to the last menu or exit menu mode idling one minute.

Beam Offset

Select Beam Offset press the ENTER button to confirm. Use the UP/DOWN button to select Iris, Frame Rot, Frame 1A, Frame 1B, Frame 2A, Frame 2B, Frame 3A, Frame 3B, Frame 4A, Frame 4B, Re. Opt. Offset or ReCal Frame, then use the UP/DOWN button to adjust the value for Iris, Frame Rot, Frame 1A, Frame 1B, Frame 2A, Frame 2B, Frame 3A, Frame 3B, Frame 4A or Frame 4B, press the ENTER button to store, the fixture will run as the channel value indicates and to select No or Yes for Re. Opt. Offset or ReCal Frame. Press the MENU button back to the last menu or exit menu mode idling one minute.

INSTALL OR REPLACE GOBOS

WARNING: Remove power from luminaires before performing maintenance. Gobos may be HOT after operation. Allow to cool before handling.

To replace a rotating gobo:

- Step 1. Remove power from luminaire.
- Step 2. Remove top and bottom head cover by loosening four crossed Slot screws to access the gobo wheel.
- Step 3. If removing gobos via bottom of head assembly, undo fan tray assembly with thumb screw to access.
- Step 4. Rotate desired gobo wheel until required gobo position is accessible.

CAUTION: Do not push on gobo glass. Press on gobo carrier only.

CAUTION: Do not touch gobos with bare fingers. Wear cotton gloves or other covering while replacing. To clean, refer to [CARE AND MAINTENANCE on page 34](#).

- Step 5. Remove current gobo by carefully pressing on edges of gobo carrier with fingers, pressing gobo toward front end of luminaire (toward lens), and out of wheel.
- Step 6. Install new gobo as follows:
 - a. Place the gobo holder on a clean, flat work surface with the teeth facing upwards. The gobo is held in place in the gobo holder by a spring. Taking care to avoid scratching or applying pressure to the gobo, lever the end of the spring out, remove the spring and then lift the gobo out of the gobo holder.
 - b. Hold the gobo with the dark side facing upwards towards the teeth in the gobo holder. Match up the alignment marks (arrowed) in the gobo and gobo holder. Lay the new gobo flat in the gobo holder.
 - c. Insert gobo carrier into wheel, ensuring that carrier snaps into place.
- Step 7. Rotate desired gobo wheel until required gobo position is accessible

Carriers

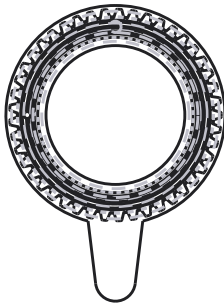

Gobo Carrier
63581988

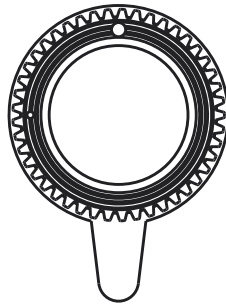

Gobo Carrier with Magnet
63581984

APPENDIX A

CARE AND MAINTENANCE

WARNING: All maintenance procedures are to be performed with power disconnected from the luminaire.

TROUBLESHOOTING

The following are a few common problems that may occur during operation with suggestions for correcting the issue.

The fixture does not work - no output and the fan does not work.

1. Check the connection of power cord and main fuse.
2. Measure the mains voltage on the main connector.

The fixture does not respond to DMX controller

1. DMX LED should be on. If not, check DMX connectors, cables to see if linked properly.
2. If the DMX LED is ON and no response to the channel, check the address settings and DMX polarity.
3. When there is intermittent DMX signal problems, check the connector pins, PCB or the previous one.
4. Try to use another DMX controller.
5. Check if the DMX cables run near or run alongside to high voltage cables that may cause damage or interference to DMX interface circuit.

FIXTURE CLEANING

Cleaning must be carried out periodically to optimize light output. Cleaning frequency depends on the environment in which the fixture operates - damp, smoky or particularly dirty surroundings cause greater accumulation of dirt on the fixture's optics.

- Clean with soft cloth using glass cleaning fluid.
- Allow parts to fully dry before use.
- Clean external optics at least every 30 days.

TECHNICAL SUPPORT

GLOBAL 24HR TECHNICAL SUPPORT:

Call: +1 214 647 7880

entertainment.service@signify.com

NORTH AMERICA SUPPORT:

Call: 877-VARI-LITE (877-827-4583)

entertainment.service@signify.com

EUROPEAN CUSTOMER SERVICE CENTER:

Call: +31 (0) 543 542 531

entertainment.europe@signify.com

©2023 Signify Holding. All rights reserved.

All trademarks are owned by Signify Holding or their respective owners. The information provided herein is subject to change, without notice. Signify does not give any representation or warranty as to the accuracy or completeness of the information included herein and shall not be liable for any action in reliance thereon. The information presented in this document is not intended as any commercial offer and does not form part of any quotation or contract, unless otherwise agreed by Signify. Data subject to change.