

WATSON[®] PRO

C-AM-2C
C-VM-2C

Dual Position Compact
Li-ion Battery Charger

Thank you for choosing Watson Pro

Please read this user manual carefully and keep
it for reference before using the charger.

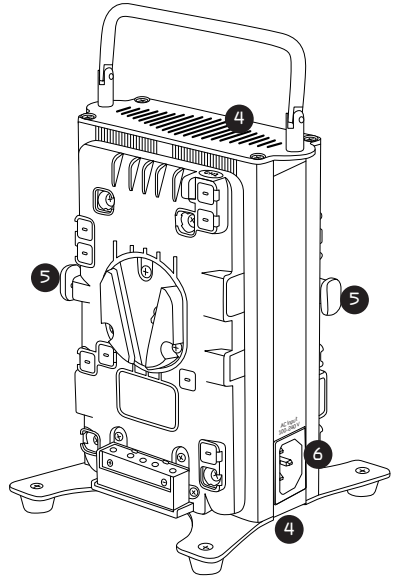
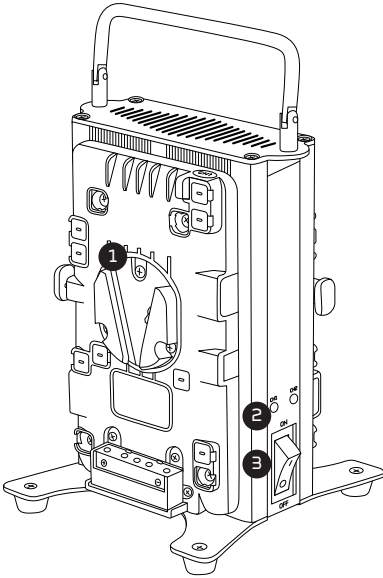

OVERVIEW

- | | | | |
|---|---------------------|---|-----------------------|
| 1 | Battery mount | 4 | Cooling vents |
| 2 | Charging indicators | 5 | Battery release latch |
| 3 | Power switch | 6 | AC power input |

ATTACHING AND CHARGING A BATTERY

- 1 Place the charger on a flat surface.
- 2 Use the included AC power cable to connect the charger to a power source.
- 3 Align the battery's V-mount or Gold mount with the battery mount in the charger.
- 4 Slide the battery into the plate until it clicks.
- 5 Flip the charger's power switch to the On position.

The charger will recognize when a battery is connected to Channel 1 or 2. The charger will simultaneously output 3 A per channel.

RELEASING THE BATTERY FROM THE CHARGER

- 1 Press and hold the battery release latch.
- 2 Slide the battery out from the charger slots, and separate it from the charging plate.

STATUS INDICATORS

| | |
|----------------|--|
| Off | • The charger is turned off. |
| Red | • The batteries are charging. |
| Green | • The charger is connected to a power source. • The batteries are fully charged. |
| Flashing Light | The charger has detected a defective battery. For more information, or to arrange service, visit www.poweredbywatson.com or call Watson Customer Service at 212-594-2120. |

SAFETY INSTRUCTIONS

- Do not store, place, or use the charger where it may come into contact with excess heat, water, or moisture.
- High-voltage internal components present the risk of electrical shock.
- Charge only at room temperature on a dry, vibration-free surface.
- Should you ever notice smoke or a strange odor coming out of the charger, immediately unplug the AC adapter from the power outlet. Using the charger under these conditions can cause fire and electric shock.
- Do not short-circuit the terminals of your battery or charger.
- Do not attempt to disassemble any part of the charger.
- The charger, adapters, and batteries may feel warm during the charging process. This is normal.
- Remove any battery after it is fully charged.
- Unplug the AC cable from the power outlet and clean the area around the prongs of the plug when necessary. The presence of dust around the prongs can cause fire.
- All images are for illustrative purposes only.

SPECIFICATIONS

| | |
|----------------------------------|---|
| AC input | 100–240 V, 47–63 Hz |
| Power Source | AC power (cable included) |
| Input Power | 100–240 V, 50–60 Hz |
| Output Charging Power | 16.8 V, 3A (x2) |
| Compatible Li-ion Battery Mounts | V-mount (C-VM-2C) Gold-mount (C-AM-2C) |
| Number of Bays | 2 |
| Multi-Bay Charging Mode | Simultaneous |
| Indicator | LED |
| Operating Temperature | -13°F–122°F (-25°C–50°C) |
| Dimensions (L × W × H) | 4.6 × 4.6 × 7.1 in. (117 × 117 × 180 mm) |
| Weight | 1.8 lb. (834 g) |

ONE-YEAR LIMITED WARRANTY

This Watson product is warranted to the original purchaser to be free from defects in materials and workmanship under normal consumer use for a period of one (1) year from the original purchase date or thirty (30) days after replacement, whichever occurs later. The warranty provider's responsibility with respect to this limited warranty shall be limited solely to repair or replacement, at the provider's discretion, of any product that fails during normal use of this product in its intended manner and in its intended environment. Inoperability of the product or part(s) shall be determined by the warranty provider. If the product has been discontinued, the warranty provider reserves the right to replace it with a model of equivalent quality and function.

This warranty does not cover damage or defect caused by misuse, neglect, accident, alteration, abuse, improper installation or maintenance. EXCEPT AS PROVIDED HEREIN, THE WARRANTY PROVIDER MAKES NEITHER ANY EXPRESS WARRANTIES NOR ANY IMPLIED WARRANTIES, INCLUDING BUT NOT LIMITED TO ANY IMPLIED WARRANTY OF MERCHANTABILITY OR FITNESS FOR A PARTICULAR PURPOSE. This warranty provides you with specific legal rights, and you may also have additional rights that vary from state to state.

To obtain warranty coverage, contact the Watson Customer Service Department to obtain a return merchandise authorization ("RMA") number, and return the defective product to Watson along with the RMA number and proof of purchase. Shipment of the defective product is at the purchaser's own risk and expense.

For more information or to arrange service, visit www.poweredbywatson.com or call Customer Service at 212-594-2353.



Product warranty provided by the Gradus Group.

www.gradusgroup.com

Watson is a registered trademark of the Gradus Group.

© 2023 Gradus Group LLC. All Rights Reserved.

GG1