





-  200 m
-  Zero Latency
-  1500 nits
-  5.5" Display
-  3D LUT



# STORM 058 PRO

### EU Environmental Protection

Waste electrical products should not be disposed of with household waste. Please recycle where facilities exist. Check with your local authority or retailer for recycling advice.



湖南光魔科技有限公司  
 GMCINE Technology Co., Ltd.  
 电话: +86400-014-7080



威固官方网站



微信公众号





## Important Information

Please read this user manual before you use this product, it contains all the notes and important things regarding operating this product. In accordance with the safety precautions and operating instructions listed on this user manual, our applies provided the product is handled properly for its intended use, but may not apply to below cases:

- Repairs or product modification and alterations have been executed by unauthorized personnel.
- The damages are caused by accidents including but not limited to lightning, fire, exposed to rain or water, and moisture.
- Do not use provided power adapter with specific power voltage which are not compliant with the rated voltage range in the attached label of the power adapter in package.
- The model label on the product has been modified or the warranty tag has been removed by unauthorized personnel.

### Safety Precaution

 Danger! High voltage	To reduce the risks of electricity, do not remove or open the cover. No user-serviceable parts are inside. Please return to original factory for maintenance
 Beware of hot surfaces!	The high temperature in the process of operating the device may cause the high risk of scalding.
 Fragile	Handle with care!

### Danger: Be careful with electricity.

- As connecting any equipment (such as any player or TV , etc.), please turn off the power to the product before any operation is undertaken.
- Power outlet: To prevent electric shock or fire, short circuit, please make sure the type of electrical plug used on the receiver's and transmitter's power cord are compliant with the rated voltage range in the attached label of the power adapter in package.
- Power cord: Do not place any heavy articles above on the power cord. To avoid being stepped on or pinched by heavy items, the power cord should not be located on the place where people pass by frequently.
- Power overloading: Avoid overloading wall's electrical outlets and extension cord or other multi-socket; otherwise could result in electric shock or fire.
- Lightning: For protection from lightning or when the product is left unattended for a long period, please disconnect it from the power source.

- Please disconnect the power cord from the power outlet when you are not using the receiver and transmitter, this will reduce the risk of electric shock or fire.

### Warning

- This product should not be exposed to dripping or splashing. Do not place any object filled with liquid on the product (eg. vases).
- To avoid electric shock, please do not block or stick anything on the air vent of product; do not remove the cover or put the object just like pins, steel wire into the gap of the air vent.
- Please place the receiver/transmitter on a flat with hard and stable surface.
- Ventilation: please do not block the air vents on the receiver/transmitter or place any heavy object on top of them . Blocking the air flow can damage the product itself. Please make sure that there is adequate ventilation distance between the receiver and TV, and also put the product away from direct sunlight or any source of heat.
- Water Exposure: To reduce the risk of electric shock or fire , please do not expose the receiver/transmitter to rain or moisture.
- We assume no responsibility for any damage or result caused by using other adapters instead of our standard adapters

### Special Notice

- Although the product has provided the function of data encryption when transmitting, you still need to pay attention to deliberate signal interception. There will be the Possibility of a third party intentionally intercept the transmission signal since the product adopt wireless communication. Please do not use the product on confidential and important communications, or life-related communications The main concern is that the content of wireless communication might be received by the third party's wireless devices deliberately or accidentally.
- The impact of radio waves (such as the following environment may cause the abnormal audio and video (blocked image, noise ...etc.).
  - 1 ) Transmit near the wall which is hard for the radio waves to get through.
  - 2 ) Quite close to the refrigerator, metal fitment and appliances, or next to the crowded situation.
- This product has been tested and manufactured to comply with national electrical safety rules, however, there will be noise caused by the interference with other machines in rare cases. If the interference is happened, please keep a certain distance away from other machines.
- The product is susceptible to interference from 5GHz wireless local area network or other wireless devices.
- Optimal range between transmitter and receiver is between 1 meter and 50 meters within line of sight indoor.
- Please do not set up the transmitter and receiver in metal shelf, or it will hinder the wireless communications.
- 1080P/60 Hz Wireless transmitting.
- It will take 15-20 seconds to boot the system before wireless communication start, the media receiver can not be operated during this time.

## ■ About the User Manual

- Please read this manual carefully before you use this product and retain it properly for future reference.
- If there is any question or difficulty about the operation of product, please feel free to contact us or the dealer.
- The company reserves the authority to modify the instruction manuals.

## ■ Overview

A wide variety of advanced features is included, such as 3D Lut Import, Waveform, Vectorscope, Brightness Histogram, Audio Meters, Focus Assist, False Color, Zebra, Single Color, Freeze, Zoom, Anamorphic, etc.

PRO VUE is a more reliable, professional and portable wireless monitor kit. Paired with Movcam follow focus system, the critical follow focus information will be displayed as overlays directly on the monitor, allowing camera assistants to pull focus and keep eyes on the image. The bright (1500 nits) and light weight (405g) monitor brings to you the most vivid productions.

## Features

- 5.5-inch Full HD touchscreen, 1500 nits brightness
- Zero latency video transmission
- Transmission range up to 200 m/ 650 ft(Line-of-Sight)
- 一发多收, 满足更多监看
- 20个频点可选
- Support HDR, 3D LUT import & video analysisi functions

## Packing List

Please check the packing list carefully after unpacking, if any part is missing, please contact the dealer.



Monitor \*1



Power Cable  
(D-tap to 2-pin LEMO) \*1



Lanyard \*1

\* Since the product's improving process, all the performance, design and accessories of our products are subject to minor change without prior notice.

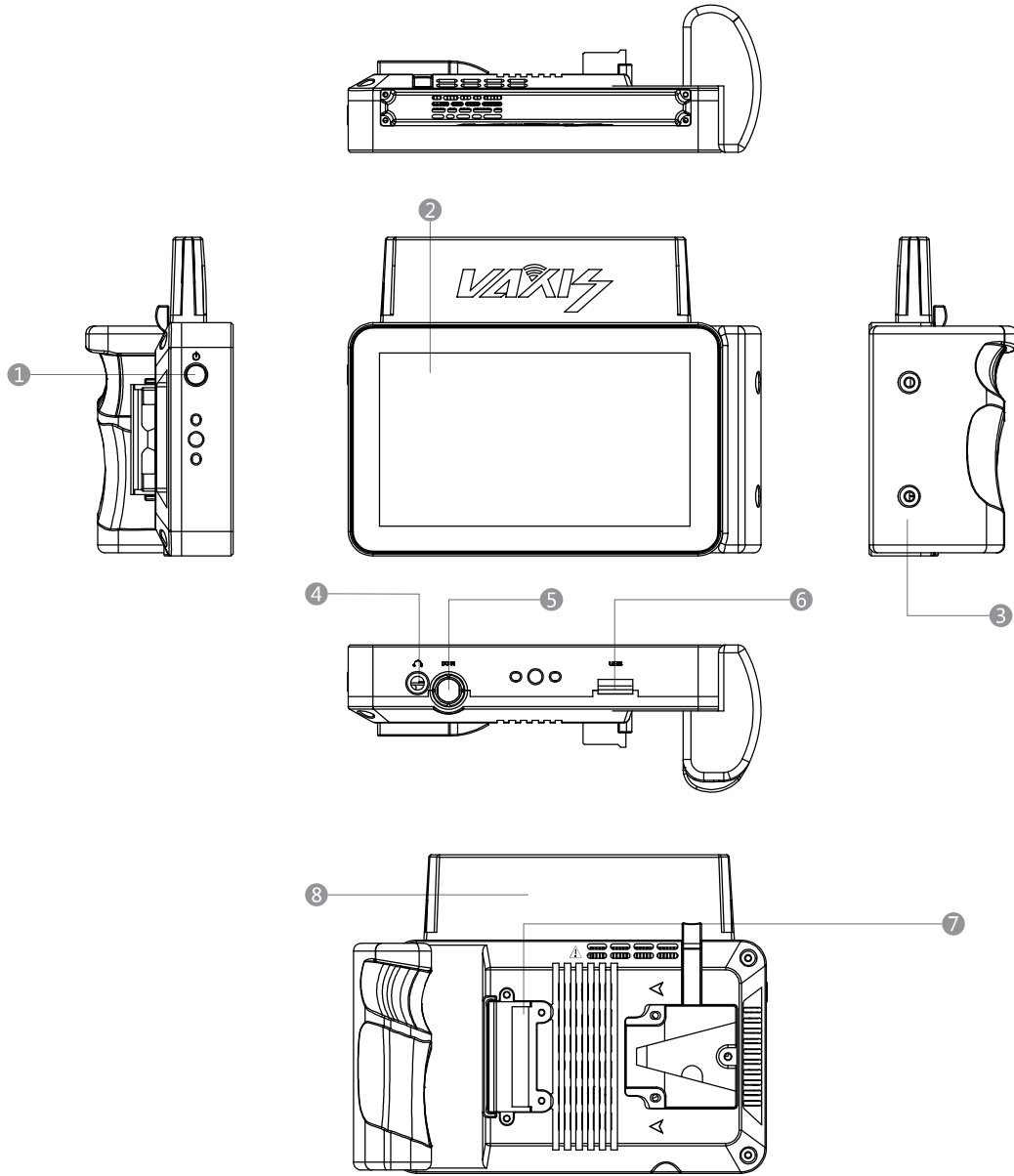

## Monitor Interface Description

	Item	Function
1	Power ON/ OFF	Short Press: Lock/Unlock the touch screen operation; Long Press for 3s: Turn ON/OFF the power
2	Touch Screen	For displaying and processing the information from transmitter
3		
4	3.5 mm Audio Jack	Audio Output
5	2-pin LEMO	
6	USB-A	For system updating/3D LUT uploading
7	V-LOCK Battery Mount	
8	Built-In Antennas	



## For Monitor

1. Install the V-Lock battery

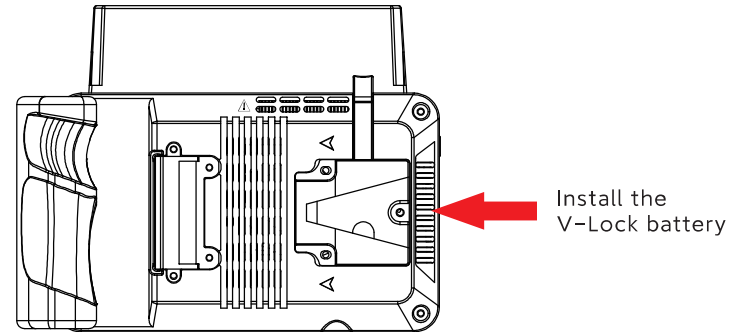



## Monitor Menu Operation

**频道：**单击屏幕调出频道设置界面,进行频道设置连接图传

手动选择频道：总共有20个频点，配合威固扫频器选择到最佳频点即可。

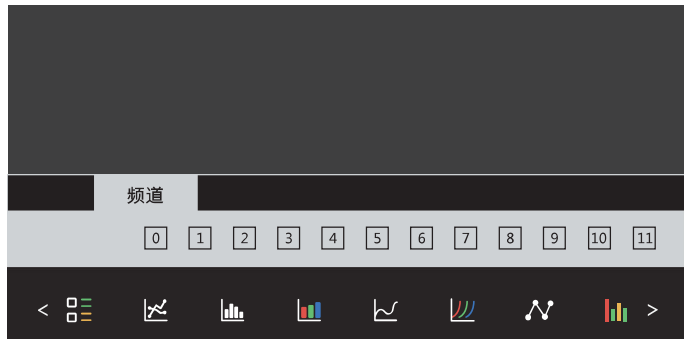

**False Color:** Tap on the screen to access the setting menu, then select False Color to do the relevant settings.

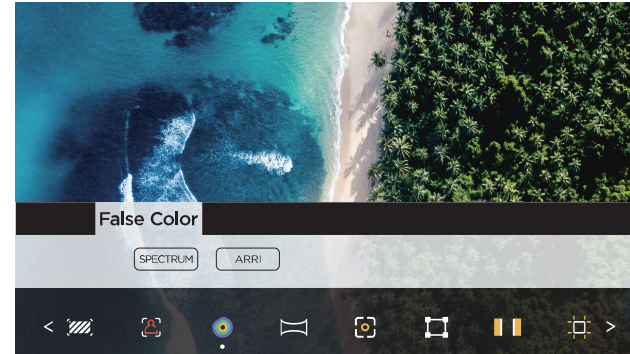

**Zebra:** Tap on the screen to access the setting menu, then select Zebra to do the relevant settings.

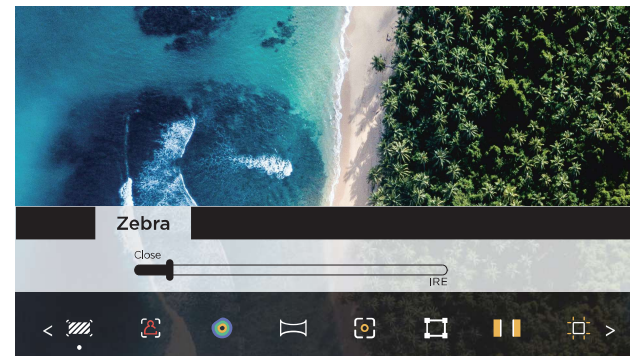

**Brightness Histogram:** Tap on the screen to access the setting menu, then select Brightness Histogram to do the relevant settings.

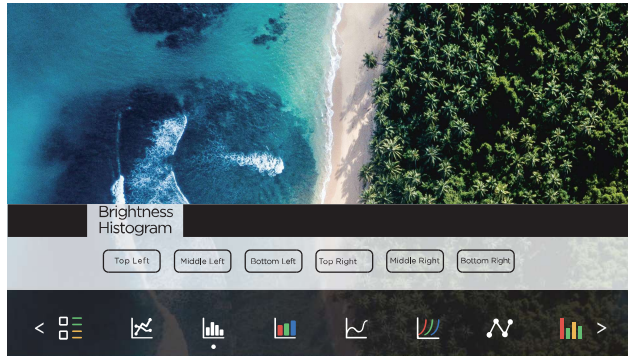

**Luminance Waveform:** Tap on the screen to access the setting menu, then select Luminance Waveform to do the relevant settings.

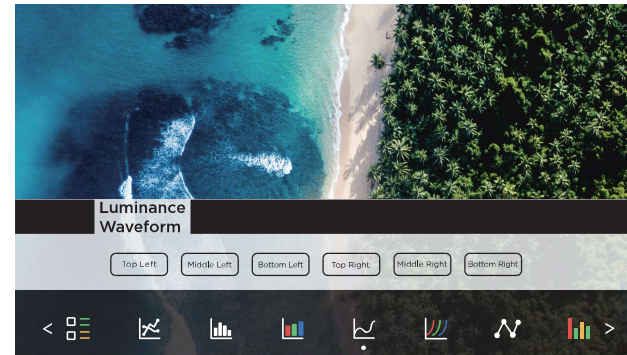

**RGB Histogram:** Tap on the screen to access the setting menu, then select RGB Histogram to do the relevant settings.

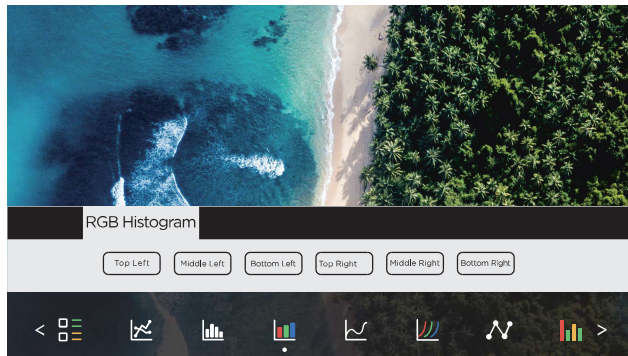

**RGB Waveform:** Tap on the screen to access the setting menu, then select RGB Waveform to do the relevant settings.

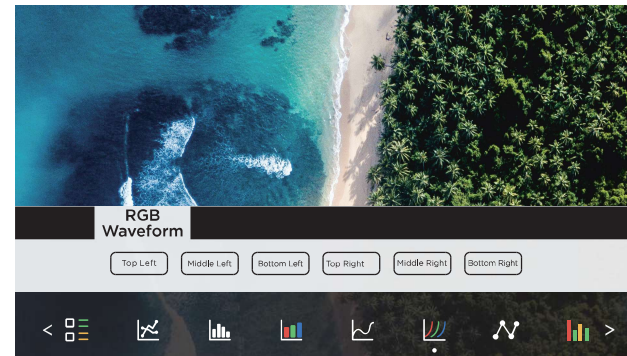

**Vectorscope:** Tap on the screen to access the setting menu, then select Vectorscope to do the relevant settings.

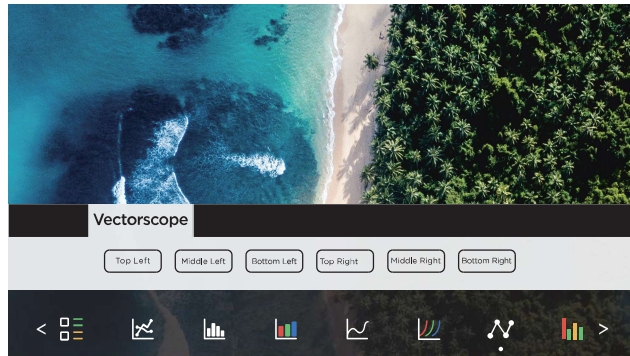

**HDR:** Tap on the screen to access the setting menu, then select HDR to do the relevant settings.

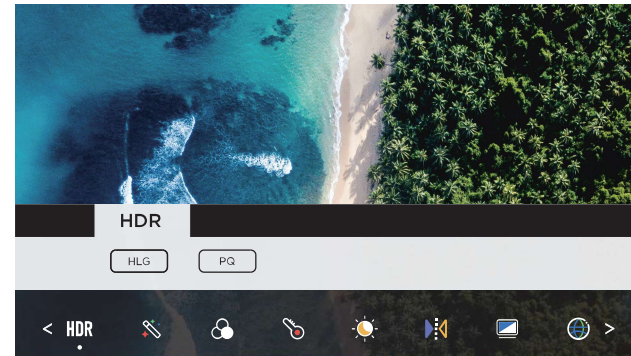

**All Wave:** Tap on the screen to access the setting menu, then select All Wave to do the relevant settings.

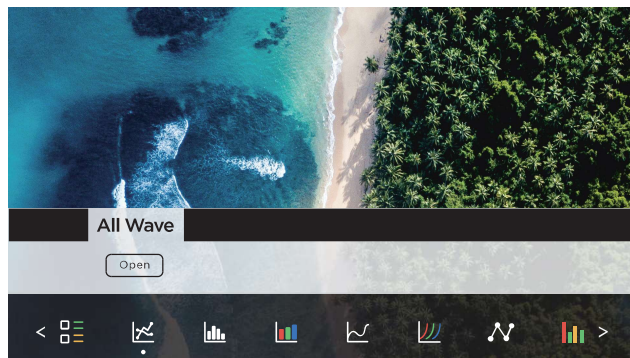

**Single Color:** Tap on the screen to access the setting menu, then select Single Color to do the relevant settings.

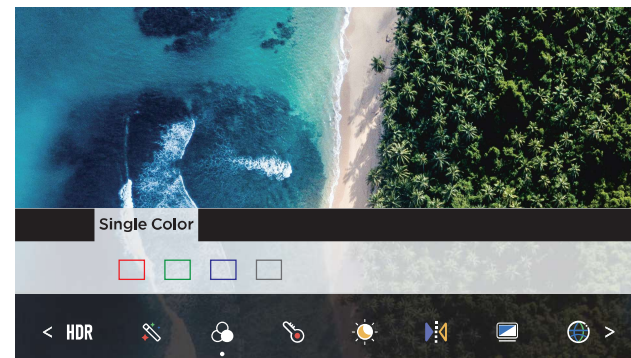

**Peaking:** Tap on the screen to access the setting menu, then select Peaking to do the relevant settings.

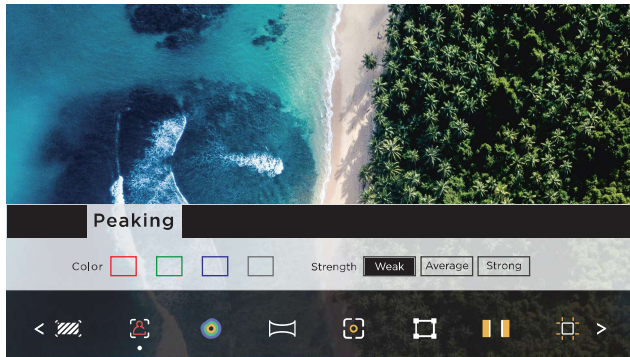

**Safe Area:** Tap on the screen to access the setting menu, then select Safe Area to do the relevant settings.

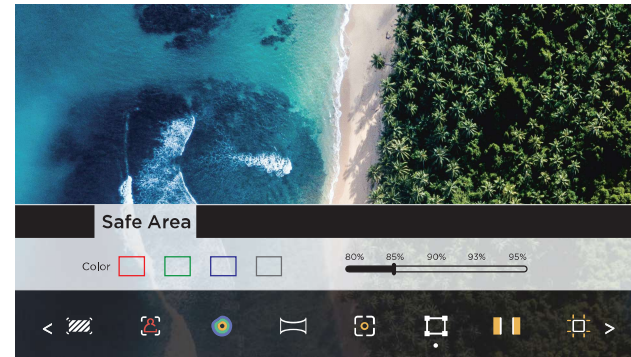

**Center Mark:** Tap on the screen to access the setting menu, then select Center Mark to do the relevant settings.

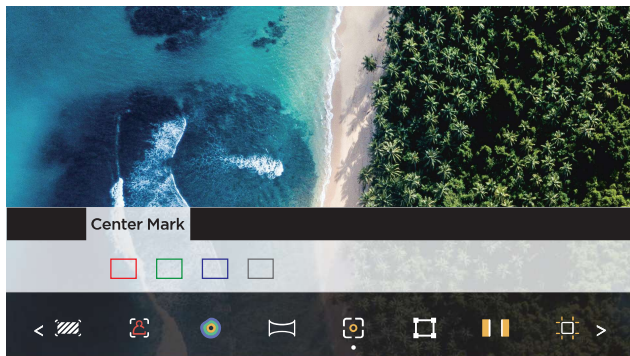

**Mark Ratio:** Tap on the screen to access the setting menu, then select Mark Ratio to do the relevant settings.

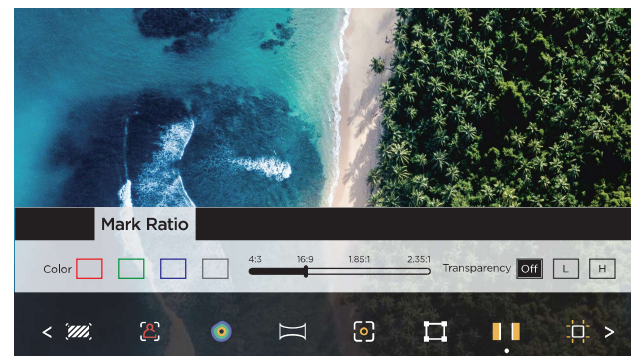

**Grid Lines:** Tap on the screen to access the setting menu, then select Grid Lines to do the relevant settings.

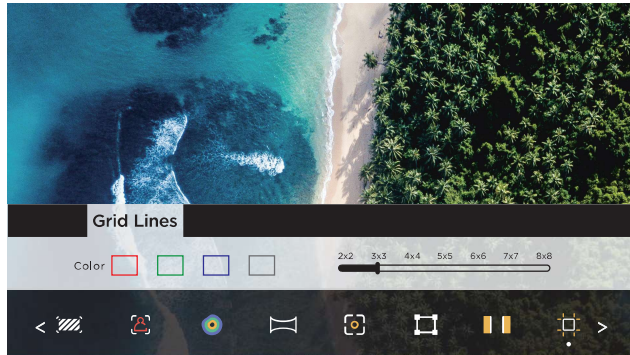

**LUT:** Tap on the screen to access the setting menu, then select LUT to do the relevant settings.

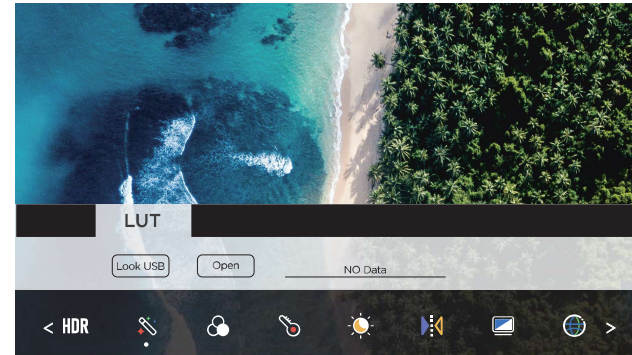

**Audio Meters:** Tap on the screen to access the setting menu, then select Audio Meters to do the relevant settings.

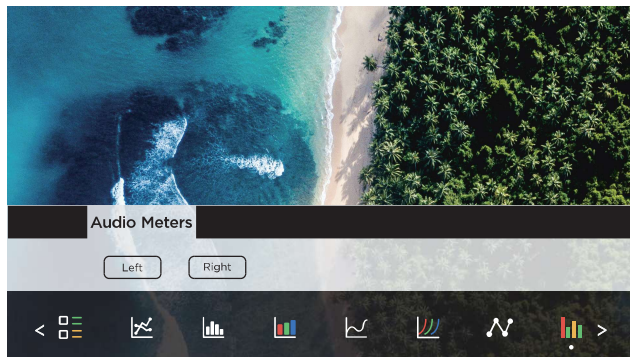

**Anamorphic:** Tap on the screen to access the setting menu, then select Anamorphic to do the relevant settings.

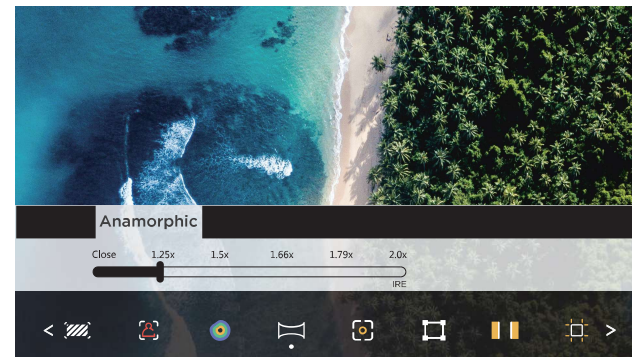

**Display Flip:** Tap on the screen to access the setting menu, then select Display Flip to do the relevant settings.

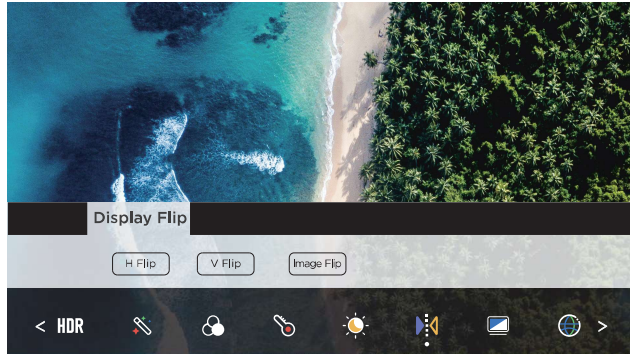

**Backlight:** Tap on the screen to access the setting menu, then select Backlight to do the relevant settings.

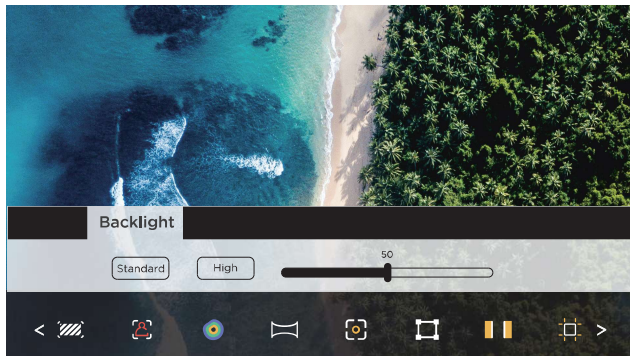

**Screen:** Tap on the screen to access the setting menu, then select Screen to do the relevant settings.

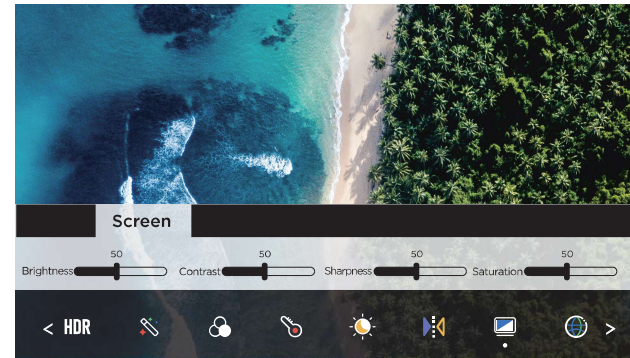

**Color Temperature:** Tap on the screen to access the setting menu, then select Color Temperature to do the relevant settings.

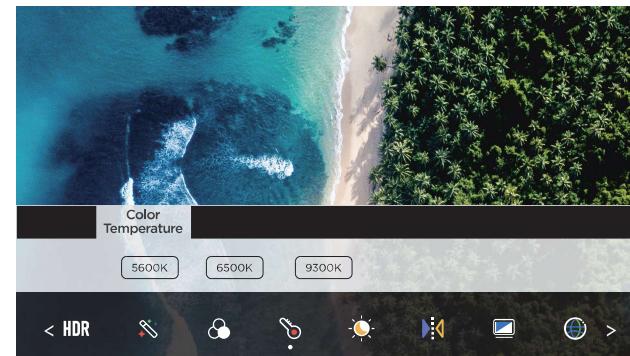

**Language:** Tap on the screen to access the setting menu, then select Language to do the relevant settings.

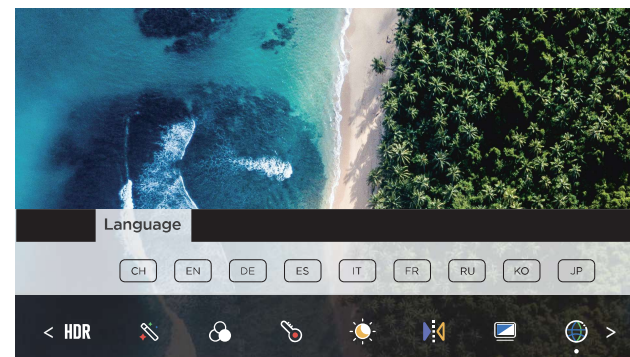

## Specification

ITEM	SPECIFICATION
Bandwidth	40MHz
Video Formats	1080p(23.98/24/25/30/50/60Hz), 1080p(23.98/24/25sF), 1080i(50/59.94/60Hz), 720p(50/59.94/60Hz), 576p, 576i, 480p, 480i
Audio Formats	PCM
Transmission Range	200 m (Line-of-Sight)
Resolution	1920x1080
Brightness	1,500 nits
Contrast	1000:1
Viewing Angle	178° ( H/V)
Backlight	LED
Antenna	Built-in antennas
Receiving Sensitivity	-70dBm
Operating Voltage	7~36 V DC
Power Consumption	15 W
Temperature	-10 - 50°C (Operating); -40 - 80°C (Storage)

# Trouble Shooting

	Troubles & Possible Reason:	Solution:
OSD Information	<b>Displaying "Link Connecting..." for long time</b>	
	Transmitter is shut off.	Power on transmitter.
	Transmitter or monitor is not placed erectly.	Place the transmitter and monitor onto the base and replace them erectly.
	The transmitter and monitor are too far away.	Move the monitor closer to the transmitter.
	Several solid walls exist between transmitter and monitor.	Reduce the number of solid walls between transmitter and monitor.
	There are too many obstacles between transmitter and monitor.	Move the monitor closer to the transmitter.
	Haven't matched frequency point of transmitter and monitor.	Rematch frequency point of transmitter and monitor.
	There is other transmitter which is under working condition near the monitor.	Power off other independent transmitter, place the monitor away from the other sources of interference.
	<b>No Video Signal received</b>	
	Transmitter and video source are not connected.	Connect the transmitter to video source by SDI/HDMI cable.
	The video source is turned Off.	Power On the video source.
	Video source were not switched to SDI/HDMI output.	Switch the Video source to SDI/HDMI output.
	Bad connect between the transmitter and the cable.	Remove and then re-plug the cable of transmitter
Abnormal working of transmitter	Reboot the transmitter.	
Problem with cable between transmitter and video source	Change the SDI/HDMI cable.	
Player NOT support the output resolution format.	Switch the output video resolution to other modes.	
Image	<b>No signal input to Monitor</b>	
	Monitor is turned OFF.	Power on monitor.
	Monitor and TV are not connected.	Connect monitor to Monitor via SDI/HDMI cable.
	Monitor NOT switched to SDI/HDMI input.	Switch Monitor to SDI/HDMI input.
	Bad contact of the cable of monitor.	Remove then re-plug the SDI/HDMI cable.
	Monitor turn into standby mode.	Switch the Monitor to normal operation mode.
	Abnormal working of monitor.	Reboot the monitor.
	<b>No image appear on Monitor</b>	
	Bad contact of monitor or cable.	Re-plug the cable of the monitor.
	Abnormal working of monitor.	Reboot the monitor.
	Monitor failure.	Please contact your retailer
	<b>Abnormal color on TV screen</b>	
	Bad contact of cable of monitor or TV	Unplug and then plug the HDMI cable of the monitor or TV.
Bad contact of cable of transmitter or video source.	Unplug and then plug the HDMI cable of the transmitter and player.	
Abnormal working of transmitter or monitor	Reboot the transmitter and monitor.	

# FCC Statement

This equipment has been tested and found to comply with the limits for a Class B digital device, pursuant to part 15 of the FCC rules. These limits are designed to provide reasonable protection against harmful interference in a residential installation. This equipment generates, uses and can radiate radio frequency energy and, if not installed and used in accordance with the instructions, may cause harmful interference to radio communications. However, there is no guarantee that interference will not occur in a particular installation. If this equipment does cause harmful interference to radio or television reception, which can be determined by turning the equipment off and on, the user is encouraged to try to correct the interference by one or more of the following measures:-Reorient or relocate the receiving antenna. Increase the separation between the equipment and receiver. Connect the equipment into an outlet on a circuit different from that to which the receiver is connected. Consult the dealer or an experienced radio/TV technician for help. To assure continued compliance, any changes or modifications not expressly approved by the party responsible for compliance could void the user's authority to operate this equipment. (Example use only shielded interface cables when connecting to computer or peripheral devices).

# FCC Radiation Exposure Statement

This equipment complies with FCC RF radiation exposure limits set forth for an uncontrolled environment. This transmitter must not be co-located or operating in conjunction with any other antenna or transmitter. This equipment complies with Part 15 of the FCC Rules.

Operation is subject to the following two conditions:

- (1) This device may not cause harmful interference, and
- (2) This device must accept any interference received, including interference that may cause undesired operation.

# Cautions!

The manufacturer is not responsible for any radio or TV interference caused by unauthorized modifications to this equipment. Such modifications could void the user authority to operate the equipment.