

LVM-246A(-N1) 24" Full HD Professional LCD Monitor

Operation manual_V1.2

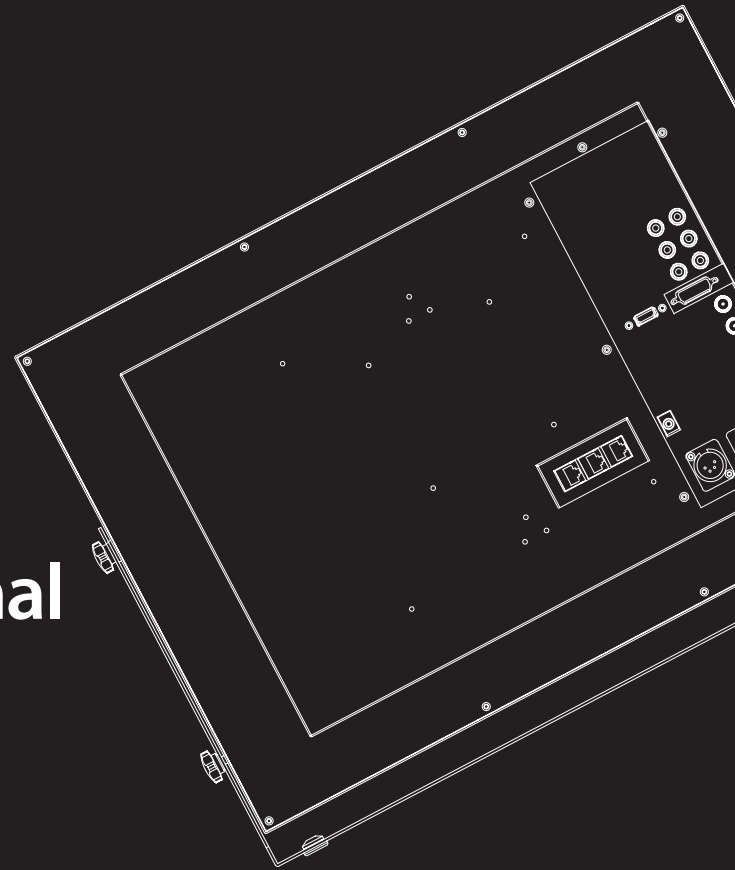



FCC (Federal Communications Commission)

This equipment has been tested and found to comply with the limits for class A digital device, pursuant to part 15 of the FCC Rules. These limits are designed to provide reasonable protection against harmful interference when the equipment is operated in a commercial environment.

This equipment generates, uses and can radiate radio frequency energy and if not installed and used in accordance with the instruction manual, may cause harmful interference to radio communications. Operation of this equipment in a residential to correct the interference at his own expense

CAUTION: Change or modifications not expressly approved by the manufacturer responsible for compliance could void the user's authority to operate the equipment.

Disposal of Old Electrical & Electronic Equipment

(Applicable in the European Union and other European countries with separate collection systems)

This symbol on the product or on its packing indicates that this product shall not be treated as household waste.

Instead it shall be handed over to the applicable collection point for the recycling of electrical and electronic equipment.

By ensuring this product is disposed of correctly, you will help prevent potential negative consequence for the environment and human health, which could otherwise be caused by inappropriate waste handling of this product. The recycling of materials will help to conserve natural resources.

Contents

01	CAUTION	04p
02	MAIN FEATURES	07p
03	CONTROLS & FUNCTIONS	08p
04	MENU ORGANIZATION & ADJUSTMENT	13p
05	MENU OPERATIONS	14p
	[1] PICTURE	14p
	[2] COLOR	16p
	[3] MARKER	16p
	[4] GPI / UMD	18p
	[5] WAVEFORM	23p
	[6] AUDIO	26p
	[7] DISPLAY & SET	27p
06	FIRMWARE UPGRADE	30p
07	BUTTON FUNCTIONS	31p
08	OTHER FUNCTIONS	34p
09	DVI / HDMI SUPPORT RESOLUTION	41p
10	PRODUCT SPECIFICATIONS	42p
11	OPTIONAL ACCESSORIES	43p

01 CAUTION

- **Always use set voltage.**
 - AC : 100 - 240V (0.6~0.4A, 50/60Hz)
 - DC : 12 - 24V (MAX 3.5A - 2A)
- All operating instructions must be read and understood before the product is operated.
- These safety and operating instructions must be kept in safe place for future reference.
- All warnings on the product and in the instructions must be observed closely.
- All operating instructions must be followed.
- Do not use attachments not recommended by the manufacturer. Use of inadequate attachments can result in accidents.
- This product must be operated on a power source specified on the specification label. If you are not sure of the type of power supply used in your home, consult your dealer or local power company. For units designed to operate on batteries or another power source, refer to the operating instructions.
- The power cords must be routed properly to prevent people from stepping on them or objects from resting on them. Check the cords at the plugs and product.
- In case of using other DC 12V/24V adapters instead of the standard adapter provided by the manufacturer, please check the proper load capacity (or current capacity) and use an adapter with stable voltage.
- Do not overload AC outlets or extension cords. Overloading can cause fire or electric shock.
- Never insert an object into the product through vents or openings. High voltage flows in the product, and inserting an object can cause electric shock and/or short internal parts. For the same reason, do not spill water or liquid on the product.
- Do not attempt to service the product yourself. Removing covers can expose you to high voltage and other dangerous conditions. Request a qualified service person to perform servicing.
- If any of the following conditions occurs, unplug the power cord from the AC outlet, and request a qualified service person to perform repairs.
 - a. When the power cord or plug is damaged.
 - b. When a liquid was spilled on the product or when objects have fallen into the product.
 - c. When the product has been exposed to rain or water.
 - d. When the product does not operate properly as described in the operating instructions. Do not touch the controls other than those described in the operating instructions. Improper adjustment of controls not described in the instructions can cause damage, which often requires extensive adjustment work by a qualified technician.
 - e. When the product has been dropped or damaged.
 - f. When the product displays an abnormal condition. Any noticeable abnormality in the product indicates that the product needs servicing.
- In case the product needs replacement parts, make sure that the service person uses replacement parts specified by the manufacturer, or those with the same characteristics and performance as the original parts. Use of unauthorized parts can result in fire, electric shock and/or other danger.

01 CAUTION

- Upon completion of service or repair work, request the service technician to perform safety checks to ensure that the product is in proper operating condition.
- When mounting the product on a wall or ceiling, be sure to install the product according to the method recommended by the manufacturer.
- Unplug the power cord from the AC outlet before cleaning the product. Use a damp cloth to clean the product. Do not use liquid cleaners or aerosol cleaners.
- Unplug the power cord from the AC outlet if you do not use the product for considerably long time.
- Do not use the product near water, such as bathtub, washbasin, kitchen sink and laundry tub, swimming pool and in a wet basement.
- Keep the product away from direct rays of the Sun-light.
- Do not place the product on an unstable cart, stand, tripod or table. Placing the product on an unstable base can cause the product to fall, resulting in serious personal injuries as well as damage to the product. Use only a cart, stand, tripod, bracket or table recommended by the manufacturer or sold with the product. When mounting the product on a wall, be sure to follow the manufacturer's instruction. Use only the mounting hardware recommended by the manufacturer.
- When relocating the product placed on a cart, it must be moved with the utmost care. Sudden stops, excessive force and uneven floor surface can cause the product to fall from the cart.
- The vents and other openings in the cabinet are designed for ventilation. Do not cover or block these vents and openings since insufficient ventilation can cause overheating and/or shorten the life of the product. Do not place the product on a bed, sofa, rug or other similar surface, since they can block ventilation openings. This product is not designed for built-in installation; do not place the product in an enclosed place such as a bookcase or rack, unless proper ventilation is provided or the manufacturer's instructions are followed.
- The LCD panel used in this product is made of glass. Therefore, it can break when the product is dropped or applied with impact. Be careful not to be injured by broken glass pieces in case the LCD panel breaks.
- Keep the product away from heat sources such as radiators, heaters, stoves and other heat generating products (including amplifiers).
- Infrared devices can cause noise or malfunction under condition as below.
 - a. parts of the body come into contact with the infrared transmitter or acoustic device.
 - b. Obstacles can cause electrical changes if there is a partition in the middle or in the wall.
 - c. Exposure to radio interference from medical equipment, microwave ovens, wireless LAN devices, etc. with the same frequency band.
- If the still image is displayed on the screen in the same position for a long period of time, the permanent burn-in on the LCD panel may occur.
So, do not display characters or markers continuously.
If the video signals or image patterns are continuously displayed at the maximum or high level of luminance, the image smearing or flicker may occur on the screen because of the LCD panel's structure and characteristics of materials used.
When the permanent burn-in, image smearing, or other damages happen on the LCD panel due to the improper use by the end user, the warranty service is not applied.

01 CAUTION

VESA WALL MOUNTING

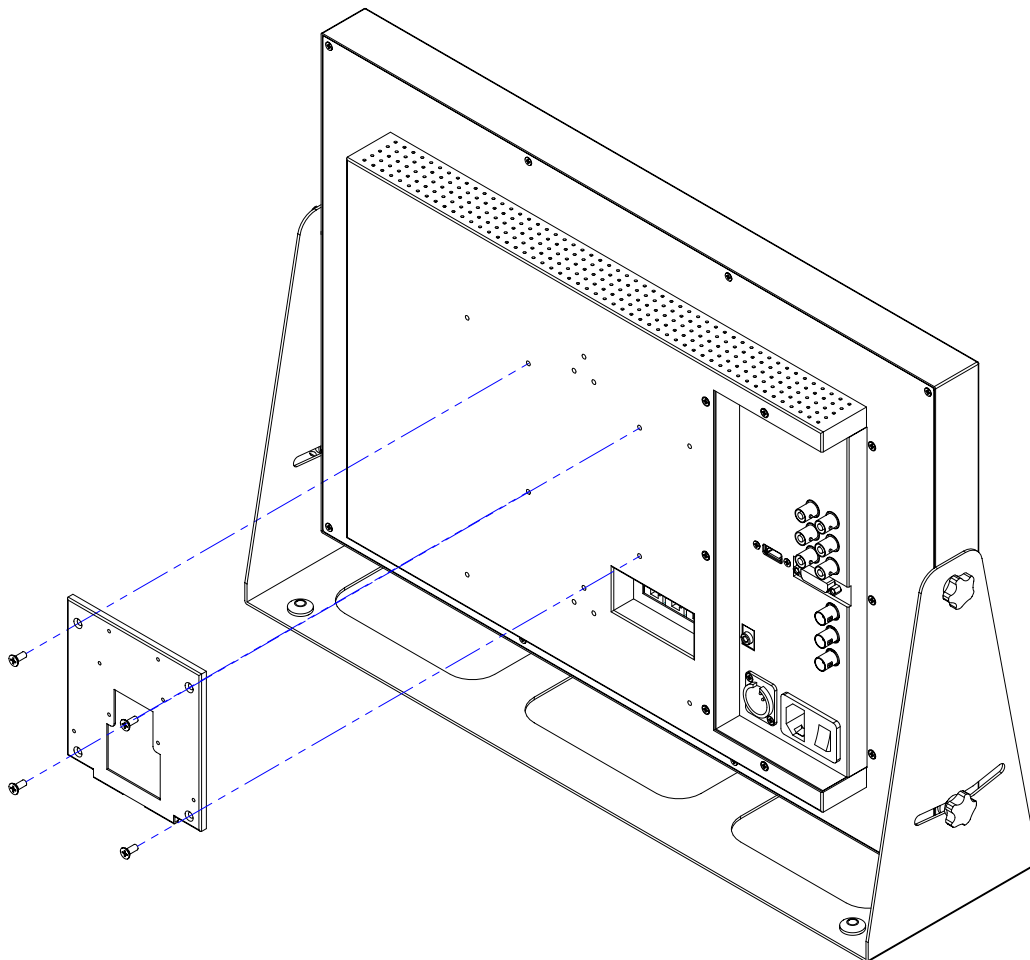

- When mounting on the wall bracket, fix the monitor using 4 pieces of M4 x 10mm screws.
- Use the 100mm x 100mm VESA MOUNTING holes on the rear housing.
- Do not install on a place other than a vertical wall.
- Do not use screws longer than the standard dimension, as they may cause damage to the inside to the monitor.
- Do not tighten the screws too much. It may damage the monitor or make the monitor fall and cause personal injury. Vidente(TVLogic) is not liable for these kinds of accidents.
- Remove the stand before installing the monitor on the wall using the wall mount kit.
- Do not install your wall mount kit while the monitor is plugged in.
It may result in personal injury due to electric shock.

02 MAIN FEATURES

LVM-246A(-N1) Monitors contain the following features:

- **Compatible with varied SDI signals**
 - The product is compatible with varied SD/HD/3G(A/B)-SDI 480i,576i,720p,1080i/p, 1080psf.
- **Compatible with analog signals**
 - The product is compatible with analog signals : Component, S-Video, Composite
- **HDMI/DVI Digital(HDCP) / Analog input support**
 - HDMI, DVI digital/analog(VGA) input is available without any other accessories.
- **All-in-one type system**
 - Slim and all-in-one type monitor that requires no other accessories and optimized for space utilization.
- **Waveform/Vector Scope/Luma(Y') zone check/Audio Level Meter support**
 - Waveform & Vector Scope support.
 - Luma(Y') zone check support. (False color)
 - Embedded Audio Level Meter support.
- **Luma(Y') zone check(Color/Zebra type)/ Range error function**
- **Audio in & out**
 - built-in internal speaker. (Embedded audio & External audio in)
 - Stereo audio out using phone jack & external audio in.
- **Knob Control**
 - Easy to adjust user configuration using the control knobs.
- **BLUE ONLY/MONO/Focus-Assist/H/V delay**
- **Internal pattern generator(0~100% Gray/ Colorbar+Pluge)**
- **Varied Markers & Safety Areas**
 - Center Marker, Safety Area Marker, Aspect Marker, Display Size(Scan).
- **1:1 SCAN / Zoom**
 - Outputs the original signal image on the screen without scaling.
 - Outputs the original signal image with zoom-in.
 - Zoom scroll function. (left/right/up/down)
- **AC/DC Compatible**
 - Basically, this product is powered by a normal AC source, and is also compatible with DC 12V ~24V
- **Remote control function**
 - The product can be remotely controlled using external switch or RS-422 communication.
- **RS422/UMD feature support**
 - This product supports protocols provided by TVLogic or a TSL protocol.
- **Additional Features**
 - Wide Viewing Angle, Loop Through (SDI/ Analog), VESA mounting, Easy to operate OSD user interface, Rack Mountable Design. High Brightness 600nits

03 CONTROLS & FUNCTIONS

LVM-246A(-N1) : FRONT

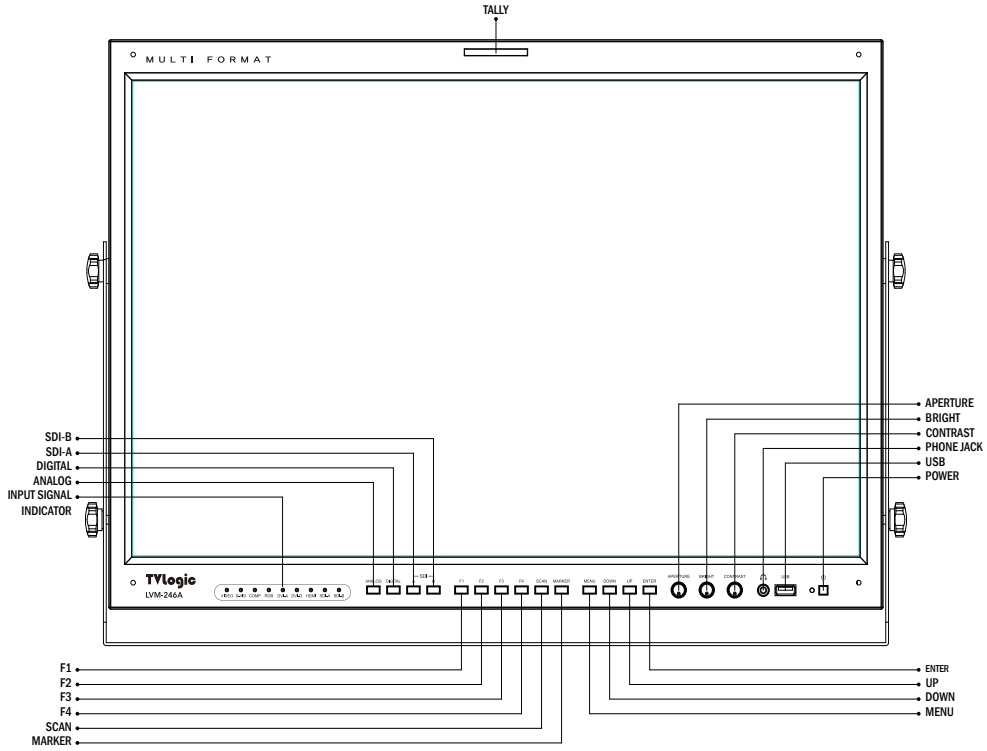

LVM-246A(-N1) : REAR

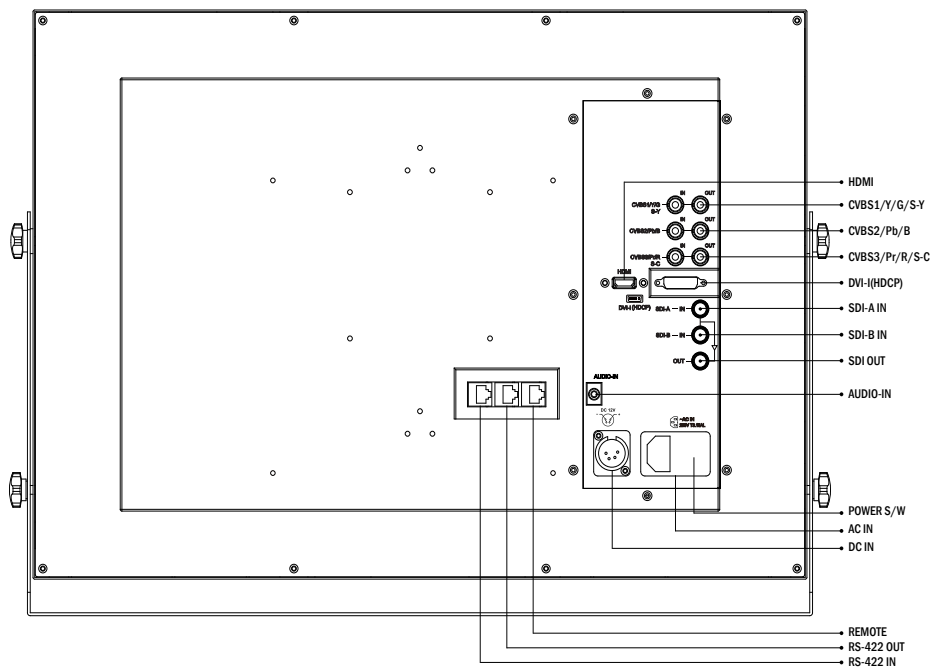

03 CONTROLS & FUNCTIONS

LVM-246A : SIDE / BIRD'S EYE VIEW

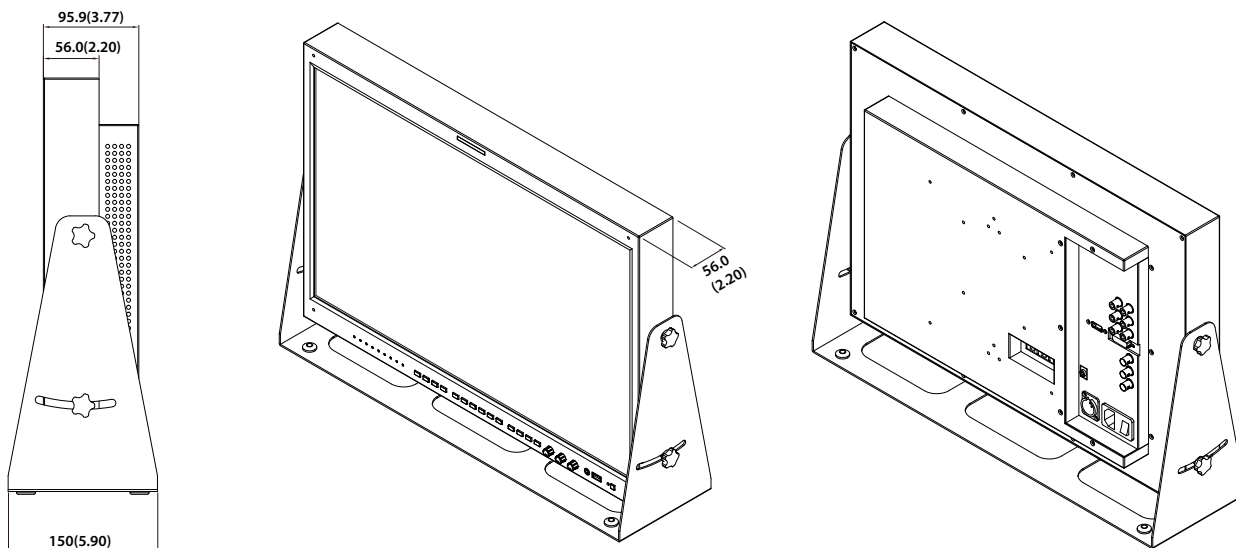

• Unit: mm(inches)

LVM-246A-N1 : SIDE / BIRD'S EYE VIEW

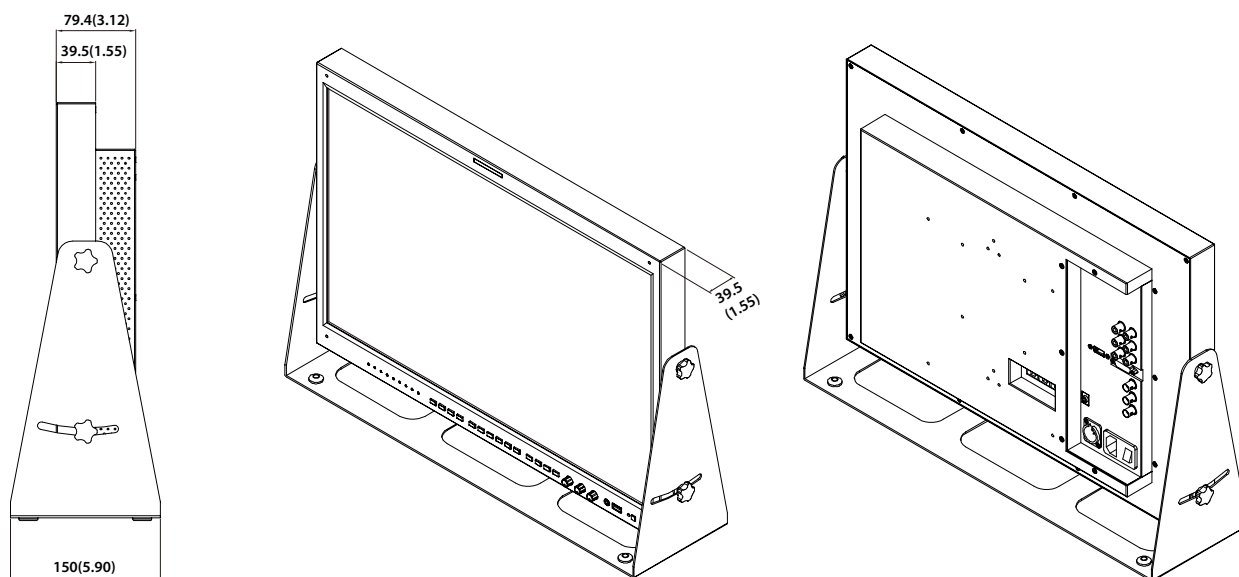

* The difference between LVM-246A and LVM-246A-N1 is the depth only. Other specifications and functions are exactly the same between the two models.

03 CONTROLS & FUNCTIONS

LVM-246A(-N1) : FRONT

- **[INPUT SIGNAL INDICATOR] Lamp**
 - Used to display the current input mode.
 - Input Mode
 - VIDEO: Composite
 - S-VID: S-Video
 - COMP: Component
 - RGB: RGB
 - DVI-A : DVI ANALOG
 - DVI-D : DVI DIGITAL
 - HDMI : HDMI
 - SDI-A : SDI-A
 - SDI-B : SDI-B
- **[ANALOG] Button/Lamp**
 - Used to select desired Analog input.
 - Press the button to activate the analog input menu-selection, then use UP and DOWN button to select desired input.
 - * Please refer to "7. Button Functions [1] ANALOG Button" for more information.
- **[DIGITAL] Button/Lamp**
 - Used to select desired Digital input. (HDMI, DVI Digital)
 - Press the Digital Button to activate the Digital input menu-selection, then use the Knob to select desired input.
 - * Please refer to "7. Button Functions [2] DIGITAL" for more information.
- **[SDI-A] Button/Lamp**
 - Used to select SDI-A input.
- **[SDI-B] Button/Lamp**
 - Used to select SDI-B input.
- **[F1 ~ F4] Button/Lamp**
 - Performs the function that the user set as hot-keys.
 - The selectable hot-key menu comes up when you hold the keys for 2 seconds.
 - You can select the hot-key functions from it.
- **[SCAN] Button/Lamp**
 - Used to change the scan mode. Press the button to activate through the scan modes: Zero Scan > 2:1 Scan > 1:1 Scan > Fit Width > Over Scan > User Aspect
 - Supported modes vary depending on the input video resolution.
 - * Please refer to "8. Other Functions [1]SCAN" for more information.
- **[MARKER] Button/Lamp**
 - Used to activate/deactivate the Marker.
 - The Marker is normally displayed when you select Aspect ratio you want in OSD Menu.
- **[MENU] Button/Lamp**
 - Activates OSD menu.
- **[DOWN] Button/Lamp**
 - Used to move the cursor down while OSD menu is activated and to decrease the value of the selected feature.
- **[UP] Button/Lamp**
 - Used to move the cursor up while OSD menu is activated and to increased the value of the selected feature.
- **[ENTER] Button/Lamp**
 - Used to confirm a chosen value.
 - Volume window is activated when OSD menu is not activated. You can adjust the volume value with UP/DOWN keys.
 - Used to move the picture position in order in 1:1 SCAN mode, when a original image is bigger than resolution.

03 CONTROLS & FUNCTIONS

LVM-246A(-N1) : FRONT

- **[APERTURE] Knob**
 - Used to adjust the picture sharpness.
The value is selectable between 0~24.
 - It is not available in DVI ANALOG.
- **[BRIGHT] Knob**
 - Used to adjust the degree of brightness.
The value is selectable between -100~100.
- **[CONTRAST] Knob**
 - Used to adjust the contrast.
The value is selectable between -100~100.
- **[AUDIO OUT] (Phone jack)**
 - Outputs the dis-embedded audio signal:
the HDMI audio signal or the SDI audio
channel which is selected in [Audio] menu.
- **[USB]**
 - Updates new firmware and color calibration.
- **[POWER INDICATOR] Lamp**
 - Indicates the status of power connection and
monitor operation.
 - The LED is off with power off.
 - The LED is red when the monitor is in waiting
mode with power on.
 - The LED is green when the monitor is
operating.
- **[POWER] Button/Lamp**
 - Turns on or off the monitor power.
- **[TALLY] Lamp**
 - Tally lamp that can be toggled in green or
red using the REMOTE(RJ-45) port.

03 CONTROLS & FUNCTIONS

LVM-246A(-N1) : REAR

- **[REMOTE] (RJ-45)**
 - Provides connection to control equipment for external monitor control.
 - Features can be changed in the [GPI / UMD] section of OSD menu.
- **[RS422 IN/OUT] (RJ-45)**
 - Controls the monitor by a protocol provided by TVLogic or supports TSL protocol.
- **[DVI-I] (DVI-I)**
 - Signal input terminal for DVI ANALOG or DVI DIGITAL signal.
- **[HDMI(HDCP)] (HDMI)**
 - Signal input terminal for HDMI signal.
- **[CVBS1/Y/G/S-Y] (BNC)**
 - Signal input terminal for COMPOSITE 1, S-VIDEO Y, COMPONENT Y, RGB G signal.
- **[CVSBS2/Pb/B] (BNC)**
 - Signal input terminal for COMPOSITE 2, RGB B, COMPONENT Pb signal.
- **[CVSBS3/Pr/R/S-C] (BNC)**
 - Signal input terminal for COMPOSITE 3, S-VIDEO C, COMPONENT Pr, RGB R signal.
- **[SDI-IN A] (BNC)**
 - Signal input terminal for 3G/HD/SD SDI signal.
- **[SDI-IN B] (BNC)**
 - Signal input terminal for 3G/HD/SD SDI signal.
- **[SDI-OUT] (BNC)**
 - Signal output terminal for 3G/HD/SD SDI input signal through SDI-IN.

* SDI Output is not activated when the unit is turned off or in Standby mode.

- **[AUDIO-IN] (Phone Jack)**
 - Inputs the analog audio out of the external equipment.
 - The analog input audio can be selected in [Audio] - [Em. Audio Left/Right] menu.
- **AC IN**
 - 100 ~ 240V (50/60Hz)
- **DC IN**
 - 12V - 24V (MAX 3.5A - 2A)

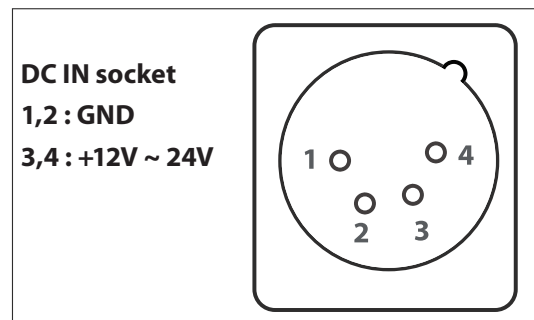

<Video input>

The way to input analog video signal.

Connector	Composite	Component		S-Video
1	CVBS1	Y	G	Y
2	CVBS2	Pb	B	No Con.
3	CVBS3	Pr	R	C

<WARNING!!>

When using the product make sure to ground, whenever possible, before connecting the input signal cable in order to prevent any possible damage to the product or connected devices. The damage may include signal noise, malfunction of main board or display panel. And the connected devices such as camera or video source player may also be influenced through signal cable. Please check if the AC power source and the power extender or power distributor is grounded.

04 MENU ORGANIZATION & ADJUSTMENT

[1] Menu Organization / [2] Menu Adjustment / [3] Menu Adjustment Procedure

[1] Menu Organization

- The product may be controlled and set system-wise through OSD displayed on the screen.

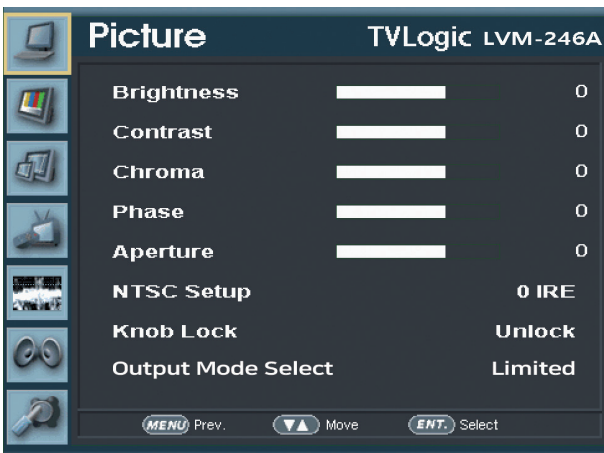

[2] Menu Adjustment

- You may control various functions using MENU, UP/DOWN and ENTER buttons on the bottom front of the monitor.

[3] Menu Adjustment Procedure

- Menu control sequence follows the order below:
 - Press MENU button to bring the OSD menu on the screen.
 - Display the desired sub menu with the UP/DOWN button.
 - After selecting a sub menu, press ENTER to select an item with the UP/DOWN button.
 - Press ENTER to select the desired item. (verified by highlighted field text turning red)
 - Press ENTER to save the new value after adjusting the value with UP/DOWN button. (Verified by highlighted field returning to default black color)
 - Press MENU to remove OSD menu from the screen.

05 MENU OPERATIONS

[1] PICTURE

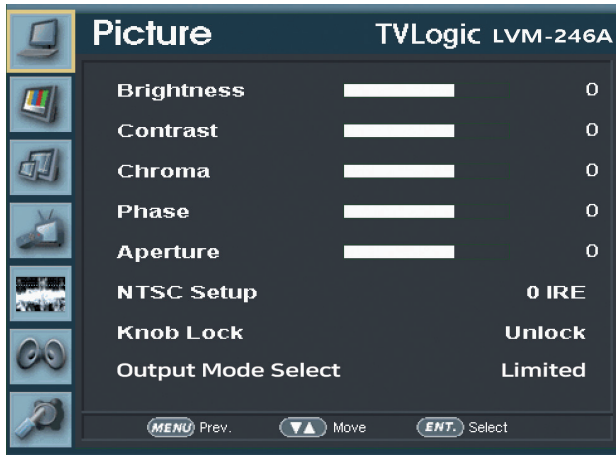

- **Brightness**
 - The item controls the degree of brightness between -100~100.
 - * Brightness can be adjusted by using a control knob on the front of the monitor.
- **Contrast**
 - The item controls contrast ratio between -100~100.
 - * Contrast ratio can be adjusted by using a control knob on the front of the monitor.
- **Chroma**
 - The item controls saturation between -50~50.
 - * Chroma can be adjusted by using a control knob on the front of the monitor.
- **Phase**
 - The item controls phase value (Hue) between -180~180.
 - * If functions only with analog video input signal.
- **Aperture**
 - The item controls the picture sharpness between 0~24.
 - * Sharpness can be adjusted by using a control knob on the front of the monitor.
- **NTSC Setup**
 - The item sets NTSC IRE value for 0(Zero setup) or 7.5 IRE.
 - It is activated in COMPOSITE 1/2/3 or S-VIDEO only NTSC signal is input.
- **Knob Lock**
 - The item locks all buttons except for power, source change and menu button in front of the monitor.
- **Output Mode Select**
 - Selects the luminance range in SDI input between [Limited] (235) and [Full] (255)

05 MENU OPERATIONS

[1] PICTURE (DVI ANALOG)

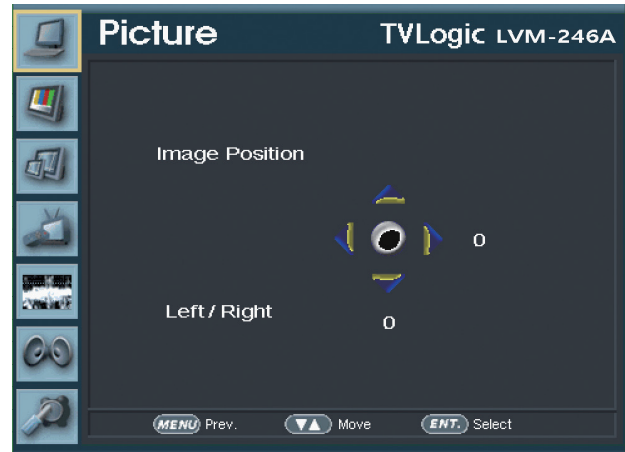
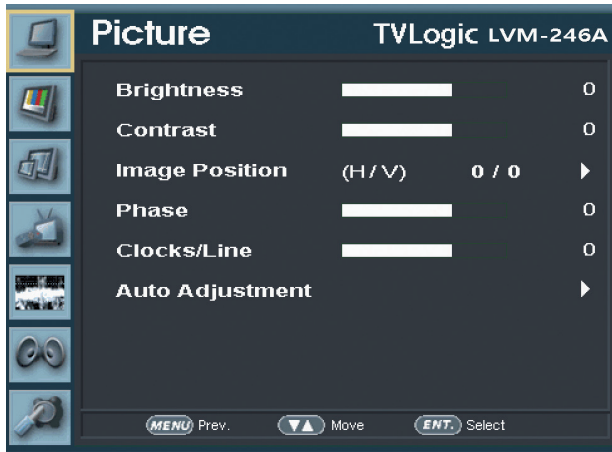

- **Brightness**
 - The item controls the degree of brightness between -100~100.
 - * Brightness can be adjusted by using a control knob on the front of the monitor.
- **Contrast**
 - The item controls contrast ratio between -100~100.
 - * Contrast ratio can be adjusted by using a control knob on the front of the monitor.
- **Phase**
 - The item controls phase value.
 - * If phase is not set correctly, the image may display artifacts and out of focus.
- **Clocks/Line**
 - The item adjusts timing for signal sync.
 - * If the signal sync is not set correctly, the image may display flickering and dropping.
- **Auto Adjustment**
 - The item adjusts the input signal automatically. Phase, Clocks/Line, and Image Position are also adjusted.
 - * If the image does not display correctly after the Auto Adjustment, select it again for correct adjustment. Auto Adjustment activates automatically when input signal resolution changes.
- **Image Position**
 - The items moves the picture position for up/down/left/right.

05 MENU OPERATIONS

[2] COLOR



- **Color Temp. (Color Temperature)**
 - The item controls color temperature and allows instant access to preset color temperature settings of 3200K, 5600K, 6500K, 9300K and USER 1/2/3.
 - Only in User1/2/3, RGB Gain, Bias(=Offset) and Color copy are activated.
- **Gain Red/Green/Blue**
 - The item controls red/green/blue gain value between -256~255.
 - * Only in User1/2/3, it is activated.
- **Bias Red/Green/Blue**
 - The item controls red/green/blue bias(Offset, Black Level) value between -100~100.
 - * Only in User1/2/3, it is activated.
- **Color Copy**
 - The item is used to copy pre-stored color temperature settings into a USER1/2/3 mode.
 - In USER mode, find and select the color temperature to be used as a starting point of custom color temperature.
 - * Only in USER1/2/3, it is activated.
- **Gamma**
 - Selects the Gamma value.
 - Selectable values are [2.2] and [2.4]

[3] MARKER



- **Marker**
 - The item selects the marker type when the MARKER is displayed on the screen.
 - Marker may only be activated by pressing the MARKER button on the front of the monitor.
 - Available marker types are OFF, 16:9, 4:3, 4:3 ON AIR, 15:9, 14:9, 13:9, 1.85:1, 2.35:1, 1.85:1 & 4:3 and USER.
- **Center Marker**
 - The item displays the CENTER MARKER on the screen.
 - The function operates only after activating the MARKER function by pressing the MARKER button on the front of the monitor.
- **Safety Area**
 - The item controls the size of the SAFETY AREA.
 - Available types are 80%, 85%, 88%, 90%, 93%, 100%, EBU ACTION 16:9, EBU GRAPHIC 16:9, EBU ACTION 14:9, EBU GRAPHIC 14:9, EBU ACTION 4:3, EBU GRAPHIC 4:3.
 - The function operates only after activating the MARKER function by pressing the MARKER button on the front of the monitor.

05 MENU OPERATIONS

[3] MARKER



● Fit Marker

- The item activates the FIT MARKER function.
- With FIT MARKER On the safety area is displayed relative to the marker in use.
- With FIT MARKER Off the safety area is displayed relative to the incoming source.
- FIT MARKER acts as below:

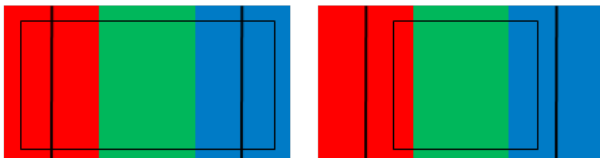

- | | |
|---------------------|---------------------|
| ● MARKER : 4:3 | ● MARKER : 4:3 |
| ● SAFETY AREA : 90% | ● SAFETY AREA : 90% |
| ● FIT MARKER : OFF | ● FIT MARKER : ON |

● Marker Mat

- The item darkens the area of the outside of MARKER.
- The degrees of darkness are between Off ~ 7.
- Larger value means darker the marker mat is.

● Marker Color

- The item controls the color of the MARKER lines.
- Available colors are white, gray, black, red, green and blue.

● Marker Thickness

- The item controls the thickness of the MARKER lines.
- The degrees of thickness are between 1 ~ 7.

● USER Marker H1

- The item controls the position of the first user defined horizontal marker line.
- Marker option USER needs to be selected.

● USER Marker H2

- The item controls the position of the second user defined horizontal marker line.
- Marker option USER needs to be selected.

● USER Marker V1

- The item controls the position of the first user defined vertical marker line.
- Marker option USER needs to be selected.

● USER Marker V2

- The item controls the position of the second user defined vertical marker line.
- Marker option USER needs to be selected.

05 MENU OPERATIONS

[4] GPI / UMD



- This product provides a **REMOTE CONTROL** mode. The user may connect **RJ-45** jack to the **REMOTE** terminal on the rear of the unit and designate a function for each pin.
- The default settings are as follows:
 PIN 1 : Analog Channel
 PIN 2 : Digital Channel
 PIN 3 : SDI-A Channel
 PIN 4 : SDI-B Channel
 PIN 5 : TALLY R
 PIN 6 : TALLY G
 PIN 7 : Power On/Off
 PIN 8 : GND

REMOTE (RJ-45)

- 1: Pin1
- 2: Pin2
- 3: Pin3
- 4: Pin4
- 5: Pin5
- 6: Pin6
- 7: Pin7
- 8: GND

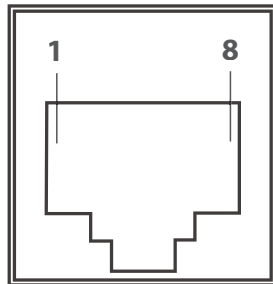

PIN NO.	Settable Values
PIN 1~6	NONE, ANALOG CHANNEL, DIGITAL CHANNEL SDI-A CHANNEL SDI-B CHANNEL TALLY R TALLY G BLUE ONLY UNDER SCAN ASPECT H/V DELAY 16:9 MARKER, 15:9 MARKER, 14:9 MARKER, 13:9 MARKER, 4:3 MARKER, 4:3 ON AIR MARKER, 1.85:1 MARKER, 2.35:1 MARKER, 1.85:1 & 4:3 MARKER CENTER MARKER, SAFETY AREA 80%, SAFETY AREA 88%, SAFETY AREA 90%, SAFETY AREA 93%, SAFETY AREA 100% D-UMD FOCUS ASSIST CC608(ANC), CC608(L21), CC708
PIN 7	POWER ON/OFF CONTROL
PIN 8	GND

05 MENU OPERATIONS

[4] GPI / UMD



- **Group ID**
 - The item is used to control many monitors in each group, when control the monitors by the protocol Tvlogic provides with RS-422/485 communication or network.
- **Monitor ID**
 - The item sets the ID of each monitor for the TVLogic control protocol or DYNAMIC UMD using RS-422/485 communication.
- **RS422 baud rate**
 - The items sets the monitor control program that TVLogic provides and Baud rate.
- **UMD Display**
 - The item sets UMD, ANC and DYNAMIC UMD.
 - UMD : Displays user customized characters on screen.
 - ANC: Displays characters embedded in SDI signal.
 - * D-UMD(S-8C) : Displays tally signal and 8 letters that are input by TSL protocol (V3.1) on the screen.
 - * D-UMD(S-16C) : Displays tally signal and 16 letters that are input by TSL protocol (V3.1) on the screen.
 - * D-UMD(D-8C) : Displays a pair of tally signal and a pair of 8 letters that are input by TSL protocol (V3.1) on the screen.
- **UMD Character**
 - The item is used to customize the characters for UMD.
 - Alphabets, numbers and special symbols are available.
 - Maximum of 8 characters.
- **UMD character color**
 - The item sets the color of the UMD letter. (White,Red,Green,Yellow,Cyan,Magenta)
 - The function only functions only when [D-UMD tally type] setting is [Default],[User color], [BG. Color],[User tally] or [User BG.].
- **UMD B.G. trans.**
 - The item sets the transparency of UMD letter box.
 - The selectable items are [Opaque], [50%], [85%] and [100%].
- **UMD size**
 - The item sets the font size of UMD and the size of UMD letter box.
 - The selectable items are [Small] and [Large].

05 MENU OPERATIONS

[4] GPI / UMD



- **Tally1 Color ~ Tally4 Color**
 - Each sets the color of TALLY1 , TALLY2, TALLY3, TALLY4.
 - The selectable colors are Red, Green, Yellow.
- **B0:0 B1:0 ~ B0:1 B0:1**
 - The item sets the color of input condition for byte0, byte1 in TSL Protocol Control Byte.
 - The selectable colors are OFF, WHITE, RED, GREEN, BLUE, YELLOW, CYAN, MAGENTA.

- **D-UMD tally type**
 - The item sets tally operation when D-UMD(D-8C) is set in UMD DISPLAY.
 - The selectable values are DEFAULT and USER COLOR.
 - * Default : Original TVLogic managing method (VRT).
 - * User color : Each user can set each tally color.
 - When user color is selected, TALLY1 COLOR ~ TALLY4 COLOR items are activated.
 - * Character : Shows tally in letter color. The operation is same as [Default].
 - * B.G. color : Show tally in letter background color. The operation is same as [Default].
 - * User tally : Sets the color the user wants receiving the signal from byte0, byte1 in TSL Protocol Control BYTE and shows tally. (Off,White,Red,Green,Blue,Yellow,Cyan,Magenta)
 - * User char. : Shows tally in letter color. The method is same as user tally one.
 - * User B.G. : Show tally in letter background color. The method is same as User tally one.

05 MENU OPERATIONS

[4] GPI / UMD

<Dynamic UMD Protocol (TSL V3.1)>

* Transmission (18 Byte) (PC or Device -> Monitor)

HEADER (1 BYTE)	CONTROL BYTE(1 BYTE)	DISPLAY DATA (16 BYTE)
--------------------	-------------------------	---------------------------

* [HEADER] : Display address (0~126) + 80 hex.

* [CONTROL BYTE]

- bit 0 : Tally 1 (1=on, 0=off)
- bit 1 : Tally 2 (1=on, 0=off)
- bit 2 : Tally 3 (1=on, 0=off)
- bit 3 : Tally 4 (1=on, 0=off)
- bit 4 : bright data (Not used)
- bit 5 : bright data (Not used)
- bit 6 : reserved (Not used)
- bit 7 : cleared to 0 (Not used)

* [DISPLAY DATA] : 16 displayable ASCII characters.



05 MENU OPERATIONS

[4] GPI / UMD

- Tally Type - Default

- S-8C(Single 8 Character) & S-16C(Single 16 Character)

Bit 1 (Tally2)	Bit 1 (Tally1)	Operation
0	0	
0	1	
1	0	
1	1	

- D-8C(Dual 8 Character)

Bit 1 (Tally4)	Bit 1 (Tally3)	Operation
0	0	
0	1	
1	0	
1	1	

- D-UMD TALLY TPYE – USER COLOR

- Color selections between TALLY1 ~ TALLY4.

The following appearance of UMD DISPLAY is set as D-UMD(D-8C), D-UMD TALLY TYPE and TALLY1 ~ TALLY4 COLOR.

D-UMD TALLY TYPE
 TALLY1 COLOR
 TALLY2 COLOR
 TALLY3 COLOR
 TALLY4 COLOR

USER COLOR
 RED
 GREEN
 RED
 YELLOW



05 MENU OPERATIONS

[5] WAVEFORM



- **Waveform type**
 - The item sets Waveform and Vectorscope.
 - The operation order is WAVE FORM > VECTOR SCOPE > WAVE FORM WIDE > WAVE FORM YCbCr > WAVE_VECTOR > FULL WAVEFORM(Y) > FULL VECTORSCOPE.
 - * Waveform : Displays the shape and form of luminance level of a signal.
 - * Vectorscope : Displays color components of the input signals.
It is divided into 2 kinds depending on HD input and SD input. 100% and 75% graphics show in a picture.
 - * Waveform YCbCr : Displays the components of luminance level and Cb/Cr components of a signal.
 - * Wave_Vector : Displays Waveform(Y) and VectorScope at the same time.
 - * Full waveform(Y) : Displays Waveform(Y) in a whole screen.
 - * Full Vectorscope : Displays Vectorscope in a whole screen.
- **Waveform Intensity**
 - The item controls the brightness of the WAVEFORM/VECTOR display.
 - Available values are between 1 ~ 63. The higher the number the brighter the waveform will be.
- **Waveform Trans.**
 - The item controls the transparency level of the WAVEFORM/VECTOR.
 - Available values are OPAQUE and TRANS.
 - * If the option is set to OPAQUE, the main OSD will overlap with the waveform/vector. However, it will automatically display it as transparent and goes back to opaque if the main OSD disappears.
- **Waveform Size**
 - The item controls the size of WAVEFORM/VECTOR.
 - Available modes are SMALL, LARGE and FULL.
- **Line Waveform**
 - Selects if the monitor shows the whole data from the picture or the data from a certain line of the picture when WAVEFORM/VECTOR functions.

05 MENU OPERATIONS

[5] WAVEFORM



• Select Line Position

- The item is used to select and check a certain Vertical Line in WAVEFORM/VECTOR.
- It is activated with Line Waveform item on.
- In order to select a certain Vertical Line, you need to go to [Waveform/Vector] of [WFM/LevelCHK] in OSD menu and select the function and choose the Vertical Line you want by the knob or UP/DOWN KEY.
- The range of SDI signal may change depending on input resolution as below.
 - * PAL : Min. 17, Max. 522
 - * NTSC : Min. 23, Max. 623
 - * 720p : Min. 26, Max. 750
 - * 1080i : Min. 21, Max. 1123
 - * 1080p : Min. 42, Max. 1121
- The range of HDMI/Analog signal may change depending on output resolution as below.
 - * Min. 0, Max. 1200

• Luma(Y') Zone Check

- Analyzes Luma (Y') of input signal and displays the analyzed area on the screen.
- There are [Color Pattern] and [Zebra Pattern] methods to display it.
- After every pixel Y' level analyzing, it is displayed with a certain color or diagonal line in right index of the screen.
- When the pixel Y' level is under 0%(16), it is displayed by green color/green diagonal line, when it is above 100%(235), it is displayed by red color/red diagonal line. Y' level between 0 ~ 100% is displayed by gray level except for selected Luma Zone.
- When [Color Pattern] method is selected, the range is displayed as yellow(bottom 10%), pink(5%), sky-blue(top 10%).
- When [Zebra Pattern] method is selected, the $\pm 5\%$ around the selected level is displayed by diagonal line.

• Luma(Y') Zone Adjust

- You can change the area of yellow, pink, sky-blue in [Color Pattern] method or diagonal line in [Zebra Pattern] method into an area the user wants.
- The setting area is 0 ~ 100%.

05 MENU OPERATIONS

[5] WAVEFORM

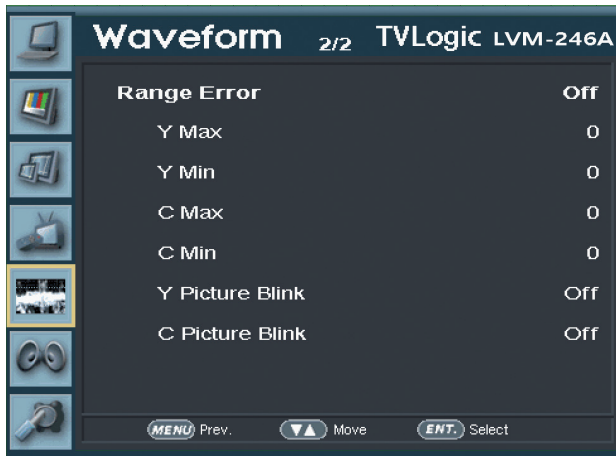

- **Range Error**

 - Selects if you perform the functions such as Y MAX, Y MIN, C MAX, C MIN, Y PICTURE BLINK, C PICTURE BLINK.
 - The value set at Y MAX, Y MIN, C MAX, C MIN is displayed in WAVEFORM/VECTOR.
 - When Y PICTURE BLINK or C PICTURE BLINK is on, the picture of the part out of the value set at Y MAX, Y MIN, C MAX, C MIN blinks.
 - * In the case of RGB input, Range Error is not supported.
 - * See section "8. Other Functions -> [8] Range Error" for more information.
- **Y Max**

 - Sets the max. value of Luma (Y') between 0~255.
 - The part exceeding the set value is displayed by red in Waveform and by blinking on the screen.
- **Y Min**

 - Sets the min. value of Luma (Y') between 0~255.
 - The part exceeding the set value is displayed by red in Waveform and by blinking on the screen.
- **C Max**

 - Sets the max. value of Chroma (C') between 0~255.
 - The part exceeding the set value is displayed by red in Waveform and by blinking on the screen.
- **C Min**

 - Sets the min. value of Chroma (C') between 0~255.
 - The part exceeding the set value is displayed by red in Waveform and by blinking on the screen.
- **Y Picture Blink**

 - Sets if the part of a picture can be blinking when Luma is out of set value at Y MAX, Y MIN.
- **C Picture Blink**

 - Sets if the part of a picture can be blinking when color components of video input is out of set value at C MAX, C MIN.

05 MENU OPERATIONS

[6] AUDIO



● Volume

- This item controls the embedded audio output volume for the internal speakers and [AUDIO OUT] on the back of the monitor
- Available values are between 0~30.

● Em. Audio Left/Right

- The item controls embedded audio channel for left/right audio out of internal speaker and [AUDIO OUT] in the back of the monitor.
- Available values are Off, CH 1~CH 16, Ext. Audio with SDI input, and Left : CH1, Right : CH2 with HDMI input.

● Level Meter

- Used to control the audio level meter.
- Available modes are OFF, 16CH(HOR.), 16CH(VER.), 8CH, 8CH Side, 4CH and 4CH Side with SDI input, and OFF, 2CH(Hor.), 2CH(Ver.) with HDMI input.
- * 16CH(HOR.) : It is displayed horizontally 8CH on the top-left, and the other 8CH on the top-right of the screen.
- * 16CH(VER.) : It is displayed vertically 8CH on the center-left, and the other 8CH on the center-right of the screen.
- * 8CH : It is displayed horizontally 4CH on the top-left, and the other 4CH on the top-right of the screen.
- * 8CH Side : It is displayed horizontally 8CH on the top-right.

* 4CH : It is displayed horizontally 2CH on the top-left, and the other 2CH on the top-right of the screen.

* 4CH Side : It is displayed horizontally 4CH on the top-right.

● Level Meter Group

- Used to set the level meter group.
- Available modes are as below.

* 8CH/8CH Side : [G1+G2]-[G2+G3]-[G3+G4]-[G1+G3]-[G1+G4]-[G2+G4]

* 4CH/4CH Side : [G1]-[G2]-[G3]-[G4]

● Level Meter Display (SDI Only)

- The item controls display method of audio level meter
- Available modes are PAIR and GROUP.

● Level Meter Reference

- The item sets audio level default.
- Available values are -18dB and -20dB.
- Audio within selected value is displayed in green and exceeded audio level is displayed in yellow. Audio exceeding -4dB is displayed in red.

● Level Meter Size

- The item controls the size of the audio level meters.
- Available modes are NORMAL and LARGE.

● Peak Decay Time

- The item sets decrease time of audio level meter top area.
- Available value is 0~100. The bigger value is, the longer decrease time is.

05 MENU OPERATIONS

[7] DISPLAY & SET



- **Key LED**
 - The item turns on / off LED in front of the monitor.
 - Even though you turn off KEY LED, when you press LED button in front of the monitor, the LED is on and after 5 sec. the LED is off.
 - **Firmware Version**
 - The item shows current firmware version.
 - **Serial Number**
 - The item shows serial number.
-
- **System Default**
 - User can use SET DEFAULT menu to initialize the values of BRIGHT, CONTRAST, CHROMA, PHASE and APERTURE of the monitor.
 - **User config set**
 - The item saves 3 user configurations.
 - Available mode is USER1, USER2, USER3.
 - Effective item is MARKER, CENTER MARKER, SAFETY AREA, MARKER MAT, MARKER COLOR in MARKER 1/2 and BRIGHT, CONTRAST CHROMA, PHASE APERTURE in PICTURE 1/3.
 - **OSD position**
 - The item sets OSD menu position.
 - Available setting is CENTER, R-T, R-B, L-B, L-T.
 - R-B and L-B are not available when WAVEFORM/VECTOR is set.

05 MENU OPERATIONS

[7] DISPLAY & SET

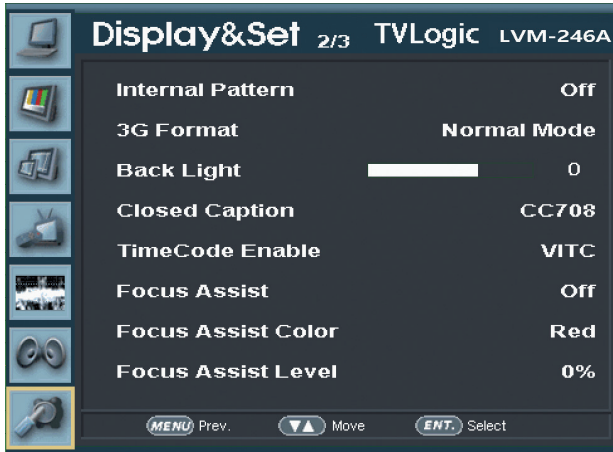

- **Internal Pattern**
 - The items displays internal Gray/ColorBar+Pluge pattern.
 - Gray pattern range is 0%~100% and is set by every 5%.
- **3G Format**
 - You can select 3G FORMAT such as (NORMAL MODE(AUTO - A 422 10BIT_YCbCr 50/60P), A 444 10/12BIT_YCbCr, A 444 10/12BIT_RGB,A 422 12BIT_YCbCr, B 444 10/12BIT_YCbCr, B 444 10/12BIT_RGB, B 422 12BIT_YCbCr, B 422 10BIT_YCbCr 50/60P) in order to support 3G SDI A/B.
 - It detects the signal automatically in NORMAL MODE, when there is Payload signal.
- **Back Light**
 - The item shows current backlight value.
 - When you Set Default, it returns to original value.(Factory shipment.) Available value is 0~100.
- **Closed Caption**
 - The item controls closed caption.
 - Available modes are OFF, 708, 608(LINE21) and 608(ANC).
 - * 608 : CEA-608-B, 708 : CEA-708-C standards display only.
- **TimeCode Enable**
 - The item sets timecode.
 - Available modes are OFF, VITC and LTC.
- **Focus Assist**
 - The item makes you check which point your camera's focus is on easily by showing a color on focused area.
 - Available value changes in order of [(Mono) On], [(Color) On] and [Off].
 - * (Mono) On : Shows edge of focused area in a designated color and the other area in black & white applying Luma (Y').
 - * (Color) On : Shows edge of only focused area in a designated color.
- **Focus Assist Color**
 - The item selects the color of FOCUS ASSIST.
 - Available values are red, green and blue.
- **Focus Assist Level**
 - The item controls focus assist level.
 - Available values are between 0~100. Larger value means greater detail detection.
 - Focus assist color is presented when the difference between the border selections exceeds the selected value.
 - The feature is only available when FOCUS ASSIST mode is selected. FOCUS ASSIST mode can be selected by pressing [BLUE ONLY/MONO] button.

05 MENU OPERATIONS

[7] DISPLAY & SET



- **S/W upgrade**
 - firmware-updates with USB memory stick(Thumb drive).
- **S/W upgrade start**
 - When S/W upgrade is [On], the monitor detects USB memory stick, and update is available, it is activated.

06 FIRMWARE UPGRADE

[1] SOFTWARE UPGRADE



- **USB memory stick(Thumb drive) that has F/W is necessary.**
- **Select Display&Set menu**
 - Connect USB memory stick to USB slot in front of the monitor.
 - Set [S/W upgrade] as [On].

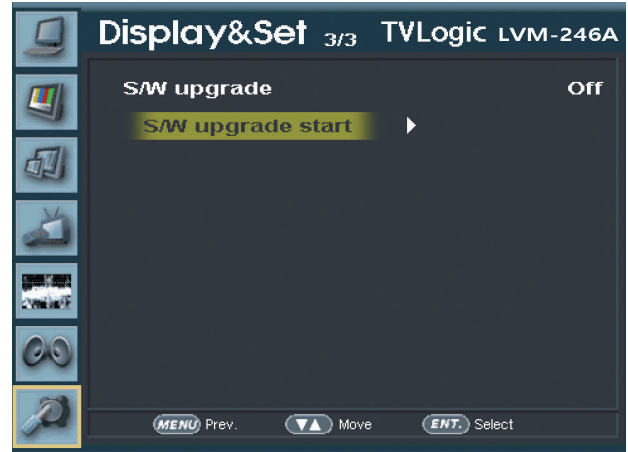

- If USB memory stick is connected correctly, [S/W upgrade start] is activated.

* if the item is not activated, please disconnect and connect the USB memory stick again. After 5 sec. do the same procedure.



- The monitor searches USB memory stick.



- Select [Yes] in [S/W upgrade start] and proceed the firmware update.

* During the update, the monitor screen is off, and nothing functions.

* After the update, TVLogic logo shows up on the screen, and the monitor initializes.

* Update can take 10~20min. depending on firmware kind.

07 BUTTON FUNCTIONS

[1] ANALOG

- **LVM series monitor supports various analog input signals.**

1. Press [ANALOG] in front of the monitor and activate OSD menu as the left photo. Select input you would like to use by Knob or UP/DOWN KEY and press the knob.
2. There is current input signal on bottom of OSD.
3. Press [ANALOG] again, then OSD menu disappears.

- * If no image displays after selecting the desired input mode, check and make sure that your connection is not lose or disconnected.

<Warning!!>

When using ANALOG mode, always check the input method and modify the setting as needed for optimized output results.



07 BUTTON FUNCTIONS

[2] DIGITAL INPUT

- LVM series monitor supports HDMI/DVI digital input signal.
 1. Press [HDMI] in front of the monitor and activate OSD menu as the left photo. Select input you would like to use by Knob or UP/DOWN KEY and press the knob.
 2. There is current input signal on bottom of OSD.
 3. Press [HDMI] again, then OSD menu disappears.
- * If no image displays after selecting the desired input mode, check and make sure that your connection is not lose or disconnected.



[3] SDI INPUT

- LVM series monitor supports two HD/SD/3G-SDI inputs.
 1. Press [SDI-A] or [SDI-B] in front of the monitor.
 2. There is current input signal on bottom of OSD.
 3. Press [SDI] again, then OSD menu disappears.
- * If no image displays after selecting the desired input mode, check and make sure that your connection is not lose or disconnected.



07 BUTTON FUNCTIONS

[4] FUNCTION KEY SET

- **Makes hot-key setting.**
 1. Hold [F1]~[F5] in front of the monitor for more than 2 sec. and activate OSD menu as the left photo.
 2. Select input you would like to use by Knob and press the knob.
 3. Afterward, [F1]~[F5] perform the designated functions.



08 OTHER FUNCTIONS

[1] SCAN

- The function can select various scan mode.
- Press [SCAN] in front of the monitor and change scan mode.

1. When you press [SCAN] button, the scan mode changes in the following order. The changing order is different depending on the input signal format.

- 1) SD signal: Zero Scan > 2:1 Scan > 1:1 Scan > Fit Width > Over Scan > User Aspect
- 2) HD signal: Zero Scan > 1:1 Scan > Over Scan > User Aspect
- 3) 2K signal: Zero Scan > Over Scan > User Aspect

2. Below is what kind of scan mode is, when you change to scan mode with a certain condition, and the condition is not matched to the signal, then the monitor skips it and goes to next scan mode.

- Over Scan : Magnifies or reduces 96% of the original image and displays it without loss of the ratio of the image.

- Zero Scan : Magnifies or reduces the original image and displays it without loss of the ratio of the image.

- 2:1 Scan : Magnifies the original image double and displays it only when the original image size is smaller than a half of the screen size.

- 1:1 Scan : Displays the original image in 1:1 ratio on the screen. When the original image is bigger than the screen, only center part of the original image can show on the screen, and the image changes by pressing [ENTER] in order of CENTER > TOP LEFT > TOP RIGHT > BOT RIGHT > BOT LEFT as following photos.

- Fit Width : Displays the original image with magnifying, when the input signal is SD.

- User Aspect : Selects [Width]/[Height] in [User Aspect] OSD and sets aspect ratio by knob or UP/DOWN KEY.

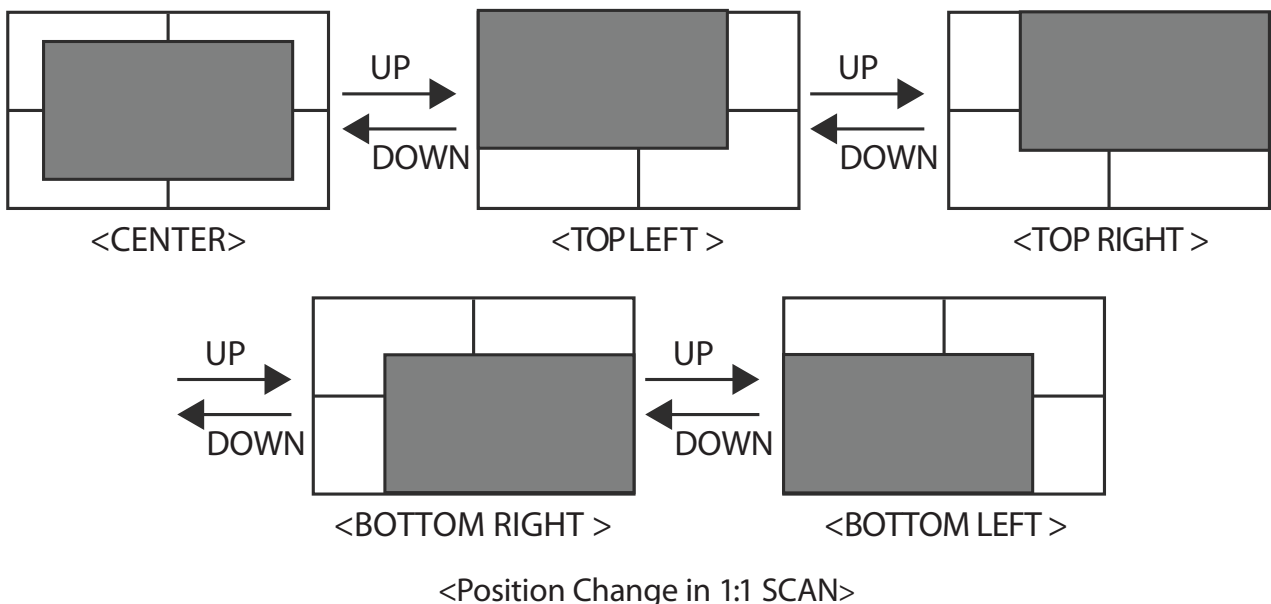

08 OTHER FUNCTIONS

[2] USER ASPECT



- Select [Aspect] mode in the OSD menu to activate the [User Aspect] mode.
- After activation, press the Knob to get ready for controlling.

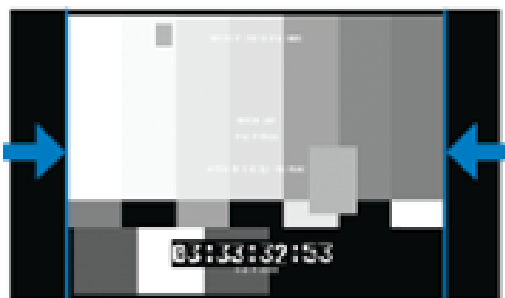
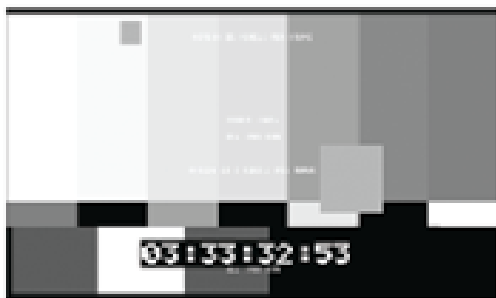

- Adjust the ratio using the Knob.
- Control range for width :
Min[100] ~ Max[1920]
- Control range for height :
Min[100] ~ Max[1200]
- The size-adjusted picture always stay in the center of the screen.

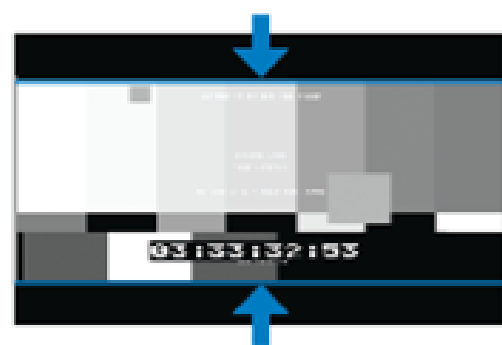
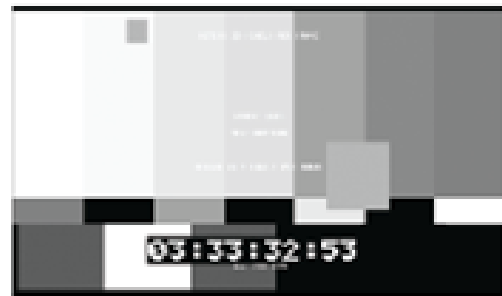

- * To adjust the 16:9 aspect ratio of 1920X1080 resolution into 2.35:1 aspect ratio, adjust the width and height as 1920X817.

08 OTHER FUNCTIONS

[3] WAVEFORM / VECTORSCOPE

- **Waveform / Vector**

- This function sets the Waveform and Vectorscope.
- Activates in order Off, Waveform, Vectorscope, Waveform wide, Waveform YCbCr, Wave_Vector, Vector_YCbCr, Full waveform(Y) and Full VectorScope.

- **Waveform Y**

- Displays the Luma(Y') component of the input signal into waveform.

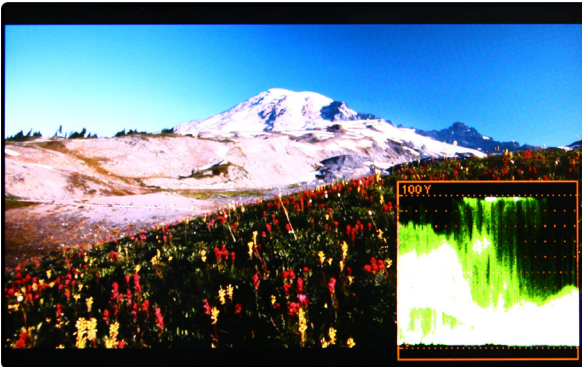

- **Waveform Cb, Cr**

- Displays the Cb, Cr components of the input signal into waveform.

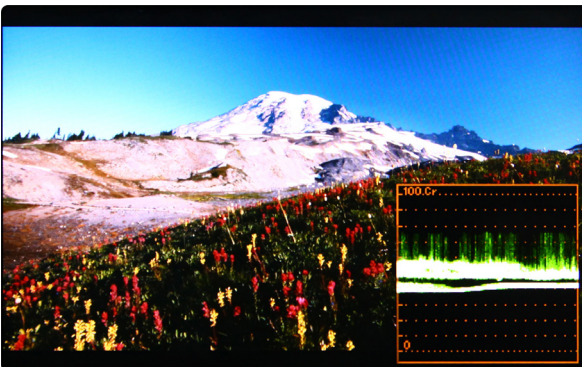
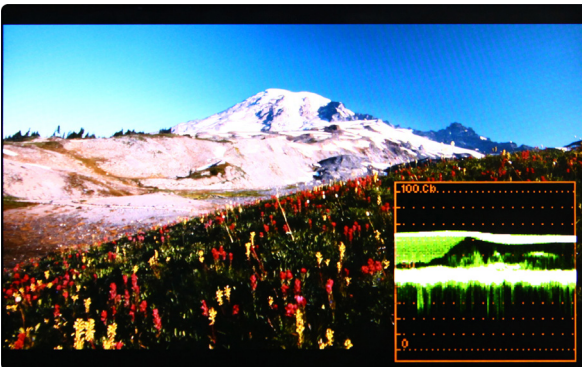

- **VectorScope**

- Displays the color components 'B-Y' and 'R-Y' of the input signals onto the X-Y axis.
- Two different types of Vetorscopes are displayed according to SD or HD input signals.
- 100% and 75% scales are indicated on the Vetorscope.

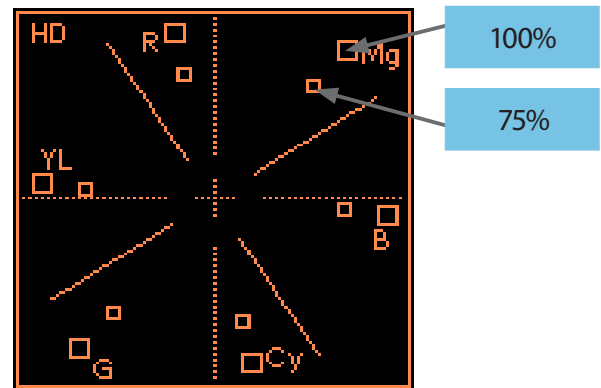
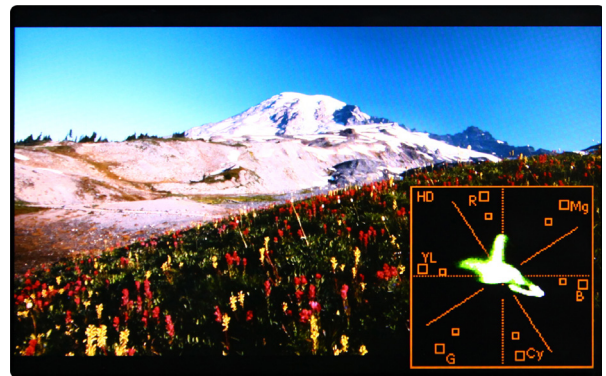

- * Wave_Vector : Displays the Waveform(Y') and the Vectorscope simultaneously.
- * Vector_YCbCr : Displays the Vectorscope and the Waveform(Y,Cb,Cr) simultaneously.
- * Full waveform(Y) : Displays the Waveform(Y) to full screen.
- * Full Vectorscope : Displays the Vectorscope to full screen.

08 OTHER FUNCTIONS

[4] LINE SELECT (Waveform/Vectorscope)

- Used to select specific Vertical Line for WaveForm/VectorScope.

- It is available when LINE WaveForm is activated.

- To activate this feature, go to [Waveform]-[Select Line Position] and use the Knob to select a vertical line.

- Control range varies according to the resolution of the input SDI signal. (shows in active line)

* PAL : Min 17, Max 522

* NTSC : Min 23, Max 623

* 720p : Min 26, Max 750

* 1080i : Min 21, Max 1123

* 1080p : Min 42, Max 1121

- Control range for HDMI/Analog signal varies according to the output resolution of the signal.

* Min 0, Max 1080

* Selected line is indicated on the screen.

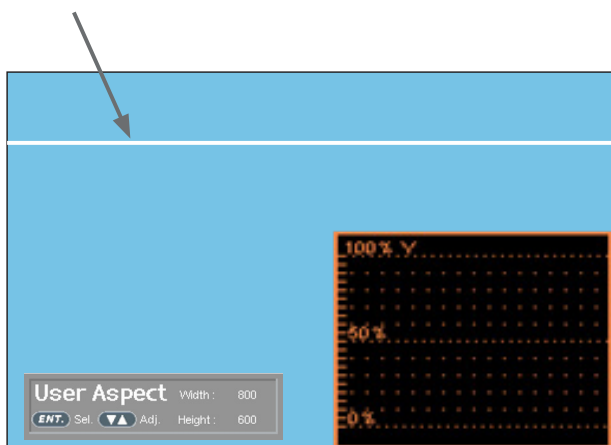

[5] ZOOM

- Used to magnify the input signal from 0% to 90%.

- Supports Zoom Width Scroll / Zoom Height Scroll function.

- Zooms IN/OUT focused on the scrolled area.

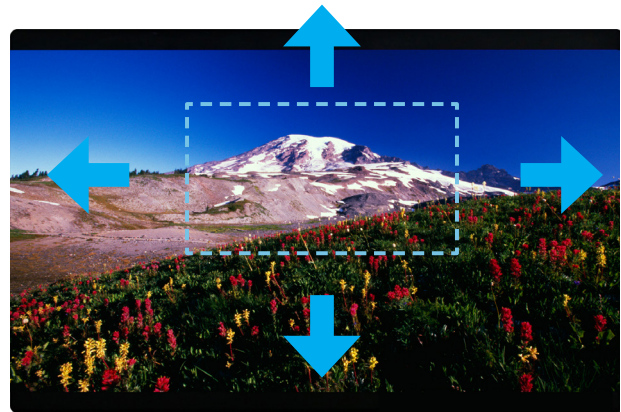

<ZOOM OFF>

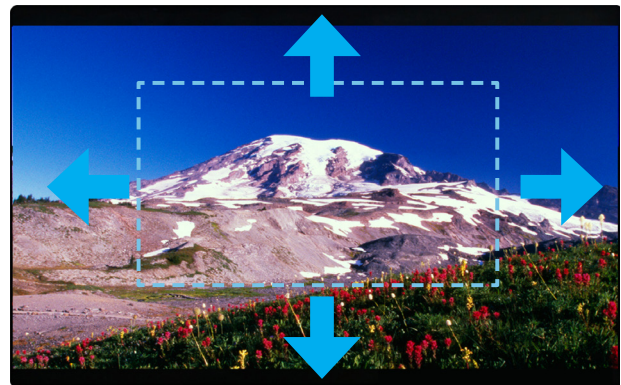

<ZOOM 50%>



<ZOOM 75%>

08 OTHER FUNCTIONS

[6] LUMA(Y') ZONE CHECK

● Color Pattern Type

- Displays the Luma(Y') level of the input image in colors.
- $Y' \geq 100\%$: Pixels with higher Y' level than 100 turn to red.
- $Y' \leq 0\%$: Pixels with lower Y' level than 0 turn to green.
- Pixels with Y' levels designated by the user are displayed as following colors - yellow, pink, cyan.
- Factory Default Y' (Border line between pink and yellow) level is 75% and pink color is assigned to pixels with Y' level from 70% to 75%.
- Yellow color is assigned to pixels with Y' level from 75% to 85%, and Cyan from 60% to 70%.
- This function is designed for better performance in setting the exposure of lighting when shooting with vDSLR cameras.

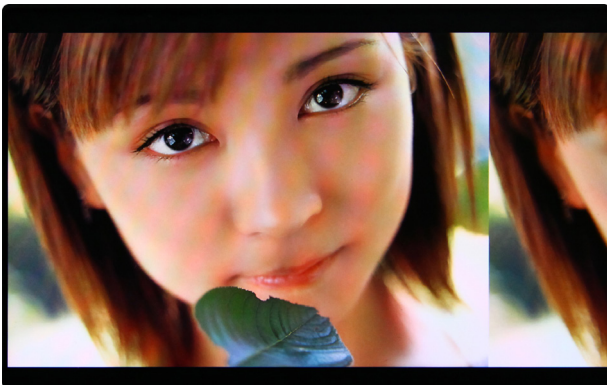

<Luma Zone Check OFF>

● Zebra Pattern Type

- Displays the pixels with designated Luma(Y') levels with zebra pattern.
- $Y' \geq 100\%$: Pixels with Y' level over 100% turn to red diagonal line.
- $Y' \leq 0\%$: Pixels with Y' level under 0% turn to green diagonal line.
- User defined Y' levels are displayed as black diagonal line.
- Factory Default Y' level is 70% and the pixels with Y' level from 65% to 75% is displayed with zebra pattern
- Pixels with 10% of Y' level is displayed as black diagonal line.
- This function is designed for better performance in setting the exposure of lighting when shooting with vDSLR cameras.



<Luma Zone Check ON_Zebra Pattern Type>

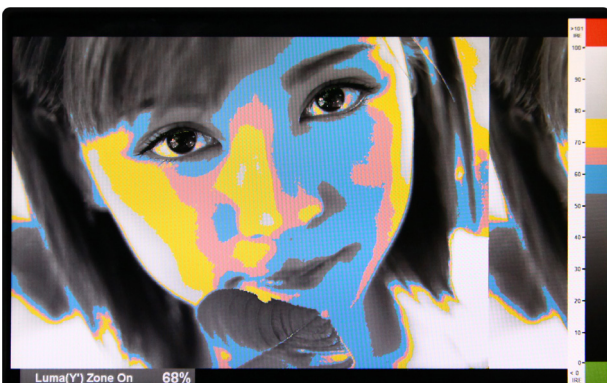

<Luma Zone Check ON_Color Pattern Type>

08 OTHER FUNCTIONS

[7] FOCUS ASSIST

- Focus Assist function assigns a color to the pixels in the shape or boundary area of the image to inform the user to make the best focus.
 - With this function, user can easily differentiate the focused area from out-focused area especially shooting with shallow depth of field.
 - Available types are [Mono] and [Color] types.
 - * [Mono] : Background image is mono type.
 - * [Color] : Background image is original color type.



<Focus Assist ON>



<Focus Assist ON>

[8] RANGE ERROR

- Pixels with Y' or C' levels exceeding the designated levels of Y MAX, Y MIN, C MAX and C MIN shall blink.
 - Analyzes the input signal's Luma(Y') and chroma information(C') and if the input signal exceeds the designated minimum value and maximum value, the pixel shall blink. This function is to help the user to easily find out any unwanted level of signals and for better exposure setting.

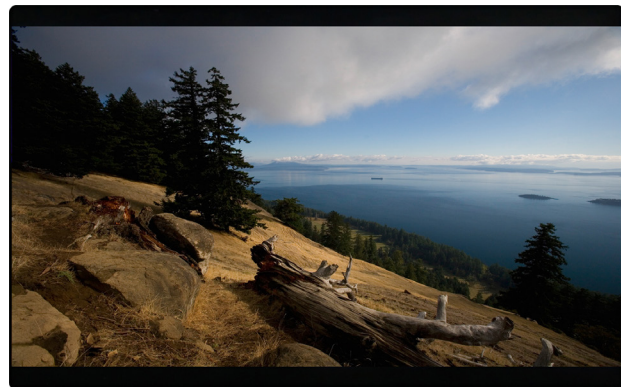

<Range Error OFF>



<Range Error ON>

08 OTHER FUNCTIONS

[9] INTERNAL PATTERN

- **Displays internally generated test patterns.**
 - The pattern consists of ColorBar and Pluge+ Grayscale Patterns.
Full screen colors of various gray levels(0~100%) are also embedded.

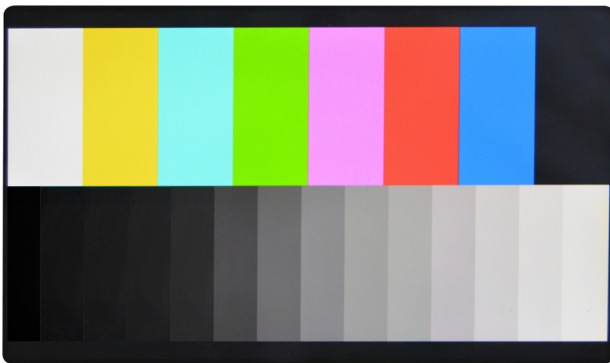

<Color Bar + Pluge Pattern>



<Gray Pattern>

09 DVI / HDMI SUPPORT RESOLUTION

DVI ANALOG / DIGITAL /HDMI SUPPORT RESOLUTION

- DVI-ANALOG mode supports the following modes :

Resolution	Frequency
640 X 480	60Hz, 75Hz
720 X 400	70Hz
800 X 600	60Hz, 72Hz, 75Hz
1024 X 768	60Hz, 70Hz, 75Hz
1366 X 768	60Hz / 75Hz
1280 X 1024	60Hz / 75Hz
1600 X 1200	60Hz
1920 X 1080	60Hz

- DVI DIGITAL Graphic mode supports the following modes :

Resolution	Frequency
640 X 480	60Hz, 75Hz
800 X 600	60Hz, 72Hz, 75Hz
1024 X 768	60Hz, 70Hz, 75Hz
1366 X 768	60Hz / 75Hz
1280 X 1024	60Hz / 75Hz
1600 X 1200	60Hz
1920 X 1080	60Hz
1920 X 1200	60Hz

- DVI DIGITAL Video mode supports the following input signals :

SMPTE-274M	1080i (60 / 59.94)
SMPTE-296M	720i (60 / 59.94)
SMPTE-125M	480i (59.94), 480p (59.94)

- DVI DIGITAL mode is separated into Graphic mode and Video mode.
- In DVI ANALOG/DIGITAL mode, ZERO scan must be selected for normal function.
- If the input image is in non-wide mode, press ASPECT button to change to wide display.

10 PRODUCT SPECIFICATIONS

Specifications		LVM-246A(-N1)
LCD	Size	24"
	Resolution	1920 x 1200 (16:10)
	Pixel Pitch	0.27(H) x 0.27(V) mm
	Color Depth	16.7M Colors (True 8 bit)
	Viewing Angle	178°(H) / 178°(V)
	Luminance of white	600cd/m ²
	Contrast Ratio	1000 : 1
	Display Area	518.4(H) x 324.0(V) mm
Input Connector	2 x BNC	SDI A/B Channel Input
	1 x HDMI	HDMI Input
	3 x BNC	Analog Video Input
	1 x DVI-I	DVI-IN
Output	1 x BNC	SDI Channel (Active Through Out)
	3 x BNC	Analog Video Output
Input Signal	3G-SDI	2.970Gb/s
	HD-SDI	1.485Gb/s
	SD-SDI	270 Mb/s
	HDMI	480i / 480p / 720p / 1080i VESA/IBM Modes
	Analog	Composite / S-Video / Component / RGB
	DVI	VESA/IBM Modes
SDI Input Signal Formats	SMPTE-425M-A/B	1080p(60/59.94/50/30/29.97/25/24/23.98/30sF/29.97sF/25sF/24sF/23.98sF)
		1080i (60/59.94/50)
	SMPTE-274M	1080i (60/59.94/50)
		1080p (30/29.97/25/24/24sF/23.98/23.98sF)
	SMPTE-296M	720p (60/59.94/50)
	SMPTE-260M	1035i (60/59.94)
	SMPTE-125M	480i (59.94)
ITU-R BT.656	576i (50)	
Remote Control & Update	1 x REMOTE	RJ-45 Input, GPI Control
	2 x RS-422	RJ-45 Input & Output, Control by TVLogic Protocol
	1 x USB	USB A type, Firmware Upgrade
Audio In		Embedded Audio / Analog Stereo (Phone Jack)
Audio Out		Internal Speaker (Mixed Mono) / Analog Stereo (Phone Jack)
Power		DC 12~24V / AC100~240V(50~60Hz)
Power Consumption (Approx.)		115W
Operating Temperature		0°C to 40°C (32°F to 104°F)
Storage Temperature		-20°C to 60°C (-4°F to 140°F)
Dimensions	Main Body	LVM-246A : 552.5 x 389 x 95.9 mm (21.75 x 15.31 x 3.78 inch) LVM-246A-N1 : 552.5 x 389 x 79.4 mm (21.75 x 15.31 x 3.12 inch)
	With Stand	586.1 x 416.8 x 150mm (23.07 x 16.41 x 5.9 inch)
	Shipping Box	675 x 535 x 280mm (26.57 x 21.06 x 11.02 inch)
Weight (with stand)		LVM-246A : 10.8kg / 23.8lbs LVM-246A-N1 : 10.0kg / 22.0lbs
Basic Accessories		AC Power Cord / Stand
Optional Accessories		Rack Mount Kit, Carrying Case, G-mount, V-mount, Acrylic Protector, ND Filter

*The specifications above may be changed without notice.

11 OPTIONAL ACCESSORIES

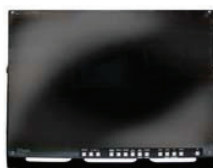

ND Glass Filter 17" 24"



External Acrylic Filter 5.6" 7" 9"



Rack Mountable Kit 7" 8.4" 9" 15" 17" 24"



Tripod Head 5.6" 7" 8.4" 9"



V-Mount 15" 17" 8.4"



Hood 5.6" 7" 9" 15" 17"



Carrying Case 5.6" 7" 8.4" 9" 15" 17" 21" 24" 32" 40" 46" 55"

RACK MOUNT ANY DISPLAY UP TO 24"



7 inch



8.4 inch



9 inch



15 inch



17 inch



21 inch



24 inch

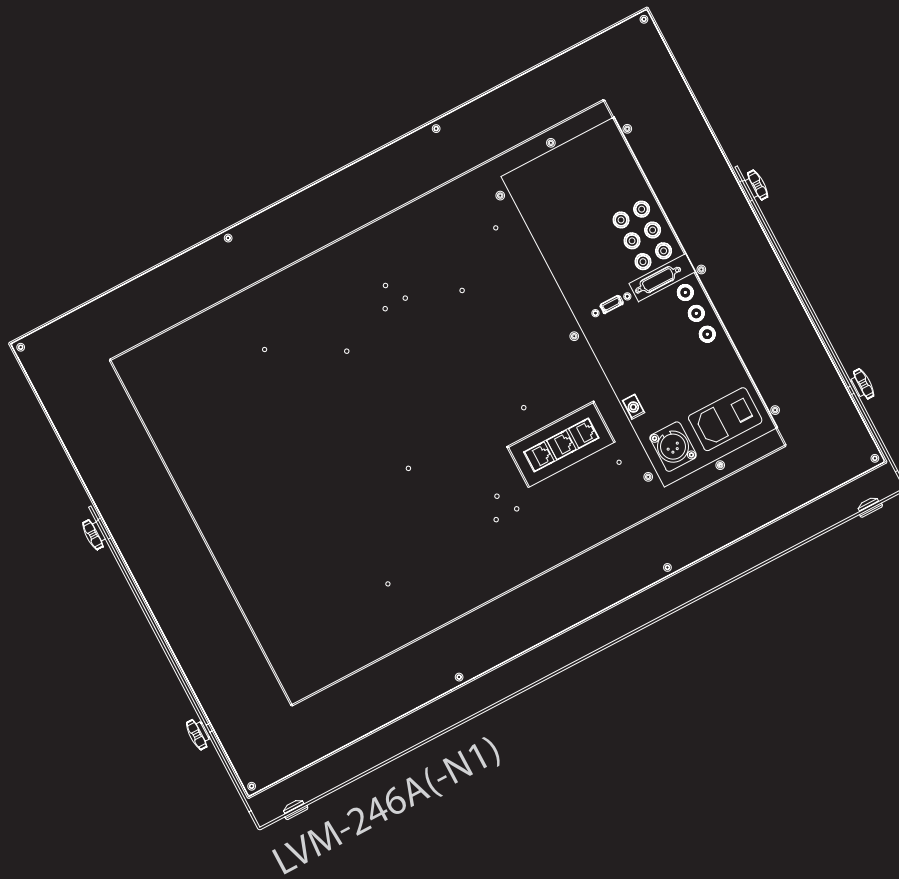

TVlogic[®] Always ON-AIR

Vidente Co., Ltd. www.tvlogic.tv  [tvlogic_official](https://www.instagram.com/tvlogic_official)

12F, ACE HIGH-END TOWER 8, 84, Gasan digital 1-ro, Geumcheon-gu, Seoul, 08590, Korea

Tel. +82-70-8668-6611 Fax. +82-2-6123-3201

E-mail. sales@tvlogic.co.kr