

RackLink™ Owner's Manual

Monitor | Control | Alert | Report | Analyze



TABLE OF CONTENTS

IMPORTANT SAFETY INSTRUCTIONS	3
INTRODUCTION.....	9
SYSTEM REQUIREMENTS	9
RS-232 CONNECTION PINOUTS.....	10
RackLink™ DEVICE DISCOVERY	11
MAC RackLink™ DEVICE DISCOVERY	14
DEVICE CONTROL.....	17
USER INTERFACE OPERATION - HOME PAGE	19
SEQUENCING MODELS - HOME PAGE.....	22
LOGS	24
DEVICE SETTINGS	26
TCP/IP SETTINGS.....	28
NOTIFICATION.....	30
ALERT THRESHOLDS	32
AUTO PING SETTINGS.....	34
PASSWORDS.....	36
RESTORING DEFAULT SETTINGS	37
UPDATING FIRMWARE.....	38
MOBILE APPLICATION FUNCTIONALITY	40
SETTING IP ADDRESS WITH DIRECT CONNECTION TO A PC	41
TROUBLESHOOTING	45
RLNK-SW715R FEATURE SET.....	46
RLNK-SW715R-NS FEATURE SET	47
RLNK-SW620R FEATURE SET	48
RLNK-SW620R-NS FEATURE SET	49
RLNK-SW215-NS FEATURE SET	50
RLNK-SW220-NS FEATURE SET	51
RLNK-MON115-NS FEATURE SET.....	52
RLNK-MON120-NS FEATURE SET.....	53
RLNK-SW815R-SP FEATURE SET	54
RLNK-SW820R-SP FEATURE SET	55
RLNK-SW415R-SP FEATURE SET	56
DIMENSIONS.....	57
WARRANTY.....	59

IMPORTANT SAFETY INSTRUCTIONS

- Read these instructions.
- Keep these instructions.
- Heed all warnings.
- Follow all instructions.
- Clean only with dry cloth.
- Only use attachments/accessories specified by the manufacturer.



DANGER HAZARDOUS VOLTAGE: The lightning flash with the arrowhead symbol, within an equilateral triangle is intended to alert the user to the presence of uninsulated dangerous voltage within the product's enclosure that may be of sufficient magnitude to constitute a risk of electric shock to persons.



WARNING: A warning alerts you to a situation that could result in serious personal injury or death.



CAUTION: A caution alerts you to a situation that may result in minor personal injury or damage to the product and/or property.

NOTE: A note is used to highlight procedures pertaining to the installation, operation, or maintenance of the product.



DANGER HAZARDOUS VOLTAGE: To reduce the risk of electrical shock: Always unplug this device from the electrical outlet before cleaning.



WARNING: Failure to read, understand and follow the following information can result in serious personal injury, damage to the equipment or voiding of the warranty. It is the responsibility of the Installer/User to ensure that this product is loaded according to specifications.



WARNING: Risk of Electric Shock: Connect the device to a properly grounded outlet only. Do not defeat the safety purpose of the polarized or grounding-type plug. A polarized plug has two blades with one wider than the other. A grounding type plug has two blades and a third grounding prong. The wide blade or the third prong is provided for your safety. If the provided plug does not fit into your outlet, consult an electrician for replacement of the obsolete outlet.

WARNING: The apparatus shall not be exposed to dripping or splashing and that no objects filled with liquids, such as vases, shall be placed on the apparatus.



WARNING: To reduce the risk of burns, fire, electric shock, or injury to persons:



- Unplug from outlet before putting on or taking off parts.
- Close supervision is necessary when this device is used by, or near children, invalids, or disabled persons.
- Use this device only for its intended use as described in these instructions. Do not use attachments not recommended by the manufacturer.
- Never operate the device if it has a damaged cord or plug, if it is not working properly, if it has been dropped or damaged, or dropped into water. Return the device to a service center for examination and repair.
- Protect the power cord from being walked on or pinched particularly at plugs, convenience receptacles, and the point where they exit from the apparatus.
- Keep the cord away from heated surfaces.
- Never drop or insert any object into any opening.
- Do not use outdoors.
- Do not operate where aerosol (spray) products are being used or where oxygen is being administered.
- To disconnect, turn all controls to the off position, then remove plug from outlet.



CAUTION: The socket-outlet shall be installed near the equipment and shall be easily accessible.



CAUTION: Use indoor in dry locations only.

Safety Instructions: Rack Mount

Elevated Operating Ambient: If installed in a closed or multi-unit rack assembly, the operating ambient temperature of the rack environment may be greater than room ambient. Therefore, consideration should be given to installing the equipment in an environment compatible with the maximum ambient temperature (T_{ma}) specified by the manufacturer.

Reduced Air Flow: Installation of the equipment in a rack should be such that the amount of air flow required for safe operation of the equipment is not compromised.

Mechanical Loading: Mounting of the equipment in the rack should be such that a hazardous condition is not achieved due to uneven mechanical loading.

Circuit Overloading: Consideration should be given to the connection of the equipment to the supply circuit and the effect that overloading of the circuit might have on overcurrent protection and supply wiring. Appropriate consideration of equipment nameplate ratings should be used when addressing this concern.

Reliable Earthing: Reliable earthing of rack-mounting equipment should be maintained. Particular attention should be given to supply connections other than direct connections to the branch circuit (e.g. use of power strips).

Disconnect Device (Pluggable Equipment): The socket-outlet shall be installed near the equipment and shall be easily accessible.

When using electrical products, basic precautions should always be followed, including the following:

- Read and follow all instructions before using.
- There are no user-serviceable components within this device. Removal of the cover from this device may present a shock hazard, and void the warranty.
- The mains plug is used as your disconnect device. This device shall remain readily operable.
- Unplug this apparatus during lightning storms or when unused for long periods of time.
- Do not overload the wall outlet where this device is being connected. Do not overload this device. Ensure the total load to this device does not exceed that which is listed in the specifications section of this manual.
- Ensure this device is connected to a properly grounded AC power source. Ensure the device is plugged into a source providing the required 120V. Do not use a plug adapter that defeats the ground pin of the AC plug.

Waste Electrical and Electronic Equipment (WEEE) Directive



Correct disposal of this product: This symbol indicates that this product must not be disposed of with household waste, according to the WEEE Directive (2012/19/EU) and your national law. This product should be taken to a collection center licensed for the recycling of waste electrical and electronic equipment (EEE). The mishandling of this type of waste could have a possible negative impact on the environment and human health due to potentially hazardous substances that are generally associated with EEE. At the same time, your cooperation in the correct disposal of this product will contribute to the efficient use of natural resources. For more information about where you can take your waste equipment for recycling, please contact your local city office or your household waste collection service.

REGULATORY COMPLIANCE FOR RLNK-MON115-NS, RLNK-MON120-NS, RLNK-SW215-NS, AND RLNK-SW220-NS MODELS

Federal Communications Commission (FCC) Compliance Statement



CAUTION: Any changes or modifications not expressly approved by the party responsible for compliance could void the user's authority to operate the equipment.

NOTE: This equipment has been tested and found to comply with the limits for a Class A digital device, pursuant to Part 15 of the FCC Rules. These limits are designed to provide reasonable protection against harmful interference when the equipment is operated in a commercial environment. This equipment generates, uses, and can radiate radio frequency energy and, if not installed and used in accordance with the instruction manual, may cause harmful interference to radio communications. Operation of this equipment in a residential area is likely to cause harmful interference in which case the user will be required to correct the interference at his own expense.

This device complies with Part 15 of the FCC Rules. Operation is subject to the following two conditions:

1. This device may not cause harmful interference.
2. This device must accept any interference received, including interference that may cause undesired operation.

Industry Canada (IC)

ICES-003 Class A Notice. This Class A digital apparatus complies with Canadian ICES-003.

EU Regulatory Compliance

This product is tested and complies with the specification for CE marking.

REGULATORY COMPLIANCE FOR ALL OTHER MODELS

Federal Communications Commission (FCC) Compliance Statement



CAUTION: Any changes or modifications not expressly approved by the party responsible for compliance could void the user's authority to operate the equipment.

NOTE: This equipment has been tested and found to comply with the limits for a Class B digital device, pursuant to part 15 of the FCC Rules. These limits are designed to provide reasonable protection against harmful interference in a residential installation. This equipment generates, uses and can radiate radio frequency energy and, if not installed and used in accordance with the instructions, may cause harmful interference to radio communications. However, there is no guarantee that interference will not occur in a particular installation. If this equipment does cause harmful interference to radio or television reception, which can be determined by turning the equipment off and on, the user is encouraged to try to correct the interference by one or more of the following measures:

- Reorient or relocate the receiving antenna.
- Increase the separation between the equipment and receiver.
- Connect the equipment into an outlet on a circuit different from that to which the receiver is connected.
- Consult the dealer or an experienced radio/TV technician for help.

Industry Canada (IC)

ICES-003 Class B Notice. This Class B digital apparatus complies with Canadian ICES-003.

EU Regulatory Compliance

This product is tested and complies with the specification for CE marking.

INSTRUCTIONS IMPORTANTES SUR LA SÉCURITÉ

- Lire ces instructions.
- Respectez tous les avertissements.
- Nettoyer uniquement avec un chiffon sec.
- Conservez ces instructions.
- Suivez toutes les instructions.
- N'utilisez que des accessoires spécifiés par le fabricant.



DANGER TENSION DANGEREUSE: Le symbole de la pointe de flèche, dans un triangle équilatéral, est destiné à alerter l'utilisateur sur la présence de tension dangereuse non isolée dans l'enceinte du produit qui peut être d'une ampleur suffisante pour constituer un risque d'électrocution.



AVERTISSEMENT: Un avertissement vous avertit d'une situation pouvant entraîner des blessures graves ou la mort.



ATTENTION: Une attention vous avertit d'une situation pouvant entraîner des blessures mineures ou des dommages au produit et/ou à la propriété.

REMARQUE: Une remarque est utilisée pour mettre en évidence les procédures relatives à l'installation, au fonctionnement ou à l'entretien du produit.



DANGER TENSION DANGEREUSE: Pour réduire le risque de choc électrique: Toujours débrancher le meuble de la prise électrique avant de le nettoyer.



AVERTISSEMENT: Ne pas lire, comprendre et suivre les informations suivantes peut entraîner des blessures graves, des dommages à l'équipement ou de la nullité de la garantie. Il incombe à l'installateur/utilisateur de s'assurer que ce produit est chargé conformément aux spécifications.



AVERTISSEMENT: Risque de choc électrique: Brancher le meuble uniquement à une prise correctement mise à la terre. Ne pas détériorer le dispositif de sécurité de la fiche polarisée ou de la fiche de terre. Une fiche polarisée possède deux broches, dont l'une plus large que l'autre. Une fiche de type terre possède deux broches et une troisième de mise à la terre. La broche large ou la troisième fiche sont fournies pour des raisons de sécurité. Si la fiche fournie n'entre pas dans votre prise de courant, veuillez faire appel à un électricien pour remplacer la prise obsolète.

AVERTISSEMENT: L'appareil ne doit pas être exposé à des éclaboussures et aucun objet rempli de liquide, comme des vases, ne doit être placé sur l'appareil.



AVERTISSEMENT: Pour réduire les risques de brûlures, d'incendie, de choc électrique ou de blessures:

- Débrancher de la prise électrique avant d'installer ou de retirer des pièces.
- Surveiller étroitement ce meuble s'il est utilisé par ou à proximité d'un enfant, d'une personne invalide ou handicapée.
- N'utiliser ce meuble que pour l'usage auquel il est destiné, tel que décrit dans la présente fiche d'instructions. Ne pas utiliser d'accessoires non recommandés par le fabricant.
- Ne jamais utiliser ce meuble si le cordon ou la prise est endommagé, s'il ne fonctionne pas correctement, s'il est tombé ou est endommagé, ou s'il est tombé dans l'eau. Renvoyer le meuble à un centre de service après-vente pour qu'il soit examiné et réparé.
- Le cordon d'alimentation doit être placé de manière à éviter qu'il soit piétiné ou pincé, notamment au niveau des prises, des réceptacles et à la sortie de l'appareil.
- Garder le cordon d'alimentation loin des surfaces chauffées.
- Ne jamais faire tomber ou introduire un objet dans une ouverture.
- Ne pas utiliser en extérieur.
- Ne pas utiliser dans des lieux où des produits aérosols sont utilisés ou à proximité d'une source d'oxygène.
- Pour débrancher, placer tous les boutons en position off, puis retirer la fiche de la prise électrique.



ATTENTION: La prise de courant doit être installée près de l'équipement et doit être facilement accessible.



ATTENTION: Pour être utilisé en intérieur dans un endroit sec seulement.

Consignes de sécurité: montage en rack

Température de fonctionnement: Si installé dans un rack fermé ou à unités multiples, la température ambiante de fonctionnement de l'environnement du rack peut être supérieure à ambiante de la pièce. Par conséquent, il faudrait envisager d'installer l'équipement dans un environnement compatible avec la température ambiante maximale (T_{ma}) spécifiée par le constructeur.

Réduction Air accréditives: Installation de l'équipement dans un rack doit être telle que la quantité de flux d'air nécessaire au bon fonctionnement de l'équipement ne soit pas compromise.

Chargement mécanique: Le montage de l'équipement dans le rack doit être telle qu'une condition dangereuse ne lié à un chargement mécanique irrégulier.

Surcharge des circuits: Il faudrait envisager à la connexion de l'équipement au circuit d'alimentation et l' effet que la surcharge du circuit pourrait avoir sur la protection contre les surintensités et le câblage d'alimentation. Examen approprié des équipements évaluations de la plaque signalétique doit être utilisée pour traiter de cette préoccupation.

Mise à la terre fiable: Fiable mise à la terre de l'équipement de montage en rack doit être maintenue. Une attention particulière devrait être accordée aux connexions d'alimentation autres que les connexions directes vers le circuit de dérivation (par exemple de l'utilisation de bandes de puissance).

Appareil Disconnect (Équipement Pluggable): La prise de courant doit être installée à proximité du matériel et doit être facilement accessible.

Lors de l'utilisation des produits électriques, des précautions de base doivent toujours être respectées, y compris les suivantes:

- Lire et suivre toutes les instructions avant l'utilisation du matériel.
- Il n'ya pas de composants réparables par l'utilisateur au sein de cet appareil. Retrait de la couverture de cet appareil peut présenter un danger d'électrocution et annuler la garantie.
- La fiche secteur est utilisée comme sectionneur de courant. Ce dispositif doit rester en état de marche.
- Débrancher cet appareil pendant les orages ou s'il n'est pas utilisé pendant de longues périodes.
- Ne surchargez pas le réceptacle de mur ou le circuit qui fournit l'énergie à ce appareil. Ne pas surcharger cette appareil. S'assurer que la charge totale à cet appareil ne dépasse pas celle qui est répertoriée dans la section des spécifications de ce manuel.
- Assurez-vous cet appareil est connecté à une source d'alimentation C/A avec mise à la terre. Assurez-vous cet appareil est branché sur une source d'alimentation fournissant les nécessaires 120V. Ne pas utiliser un adaptateur qui contrecarre la broche de terre de la prise du cordon d'alimentation.

Directive sur les déchets d'équipements électriques et électroniques (WEEE)



Élimination correcte de ce produit: Ce symbole indique que ce produit ne doit pas être éliminé avec les ordures ménagères, conformément à la directive WEEE (2012/19/EU) et à votre législation nationale. Ce produit doit être déposé dans un centre de collecte agréé pour le recyclage des déchets d'équipements électriques et électroniques (EEE). La mauvaise manipulation de ce type de déchets pourrait avoir un impact négatif possible sur l'environnement et la santé humaine en raison de substances potentiellement dangereuses généralement associées aux EEE. Dans le même temps, votre coopération dans l'élimination correcte de ce produit contribuera à une utilisation efficace des ressources naturelles. Pour plus d'informations sur les lieux de recyclage de vos équipements usagés, veuillez contacter votre mairie ou votre service de collecte des ordures ménagères.

CONFORMITÉ RÉGLEMENTAIRE POUR LES MODÈLES RLNK-MON115-NS, RLNK-MON120-NS, RLNK-SW215-NS ET RLNK-SW220-NS

Déclaration de conformité de la Federal Communications Commission (FCC)



ATTENTION: Les changements ou modifications non expressément approuvés par le fabricant peuvent annuler le droit de l'utilisateur à utiliser l'équipement.

REMARQUE: Cet équipement a été testé et jugé conforme aux limites de la classe A des appareils numériques, conformément à la section 15 de la réglementation de la FCC. Ces limites sont conçues pour fournir une protection raisonnable contre les interférences nuisibles lorsque l'équipement est utilisé dans un environnement commercial. Cet équipement génère, utilise et peut émettre de l'énergie radiofréquence et, si non installé et utilisé conformément au manuel d'instruction, peut provoquer des interférences dans les communications radio. Le fonctionnement de cet équipement dans une zone résidentielle est susceptible de provoquer des interférences nuisibles, auquel cas l'utilisateur sera tenu de corriger les interférences à ses propres frais.

Cet appareil est conforme à la partie 15 des règlements de la FCC. Le fonctionnement est soumis aux deux conditions suivantes:

1. Cet appareil ne doit pas causer d'interférences nuisibles.
2. Cet appareil doit accepter toute interférence reçue, y compris les interférences susceptibles de provoquer un fonctionnement indésirable.

Industrie Canada (IC)

ICES-003 Avis NMB-003, Classe B. Cet appareil numérique de la classe B est conforme à la norme NMB-003 du Canada.

Conformité Réglementaire au EU

Le produit est testé et conforme aux spécifications du marquage CE.

CONFORMITÉ RÉGLEMENTAIRE POUR TOUS LES AUTRES MODÈLES

Déclaration de conformité de la Federal Communications Commission (FCC)



ATTENTION: Les changements ou modifications non expressément approuvés par le fabricant peuvent annuler le droit de l'utilisateur à utiliser l'équipement.

REMARQUE: Cet équipement a été testé et jugé conforme aux limites d'un dispositif numérique de classe B, conformément à la partie 15 des règles de la FCC. Ces limites sont conçues pour fournir une protection raisonnable contre les interférences nuisibles dans une installation résidentielle. Cet équipement génère, utilise et peut émettre de l'énergie radiofréquence et, si non installé et utilisé conformément aux instructions, peut provoquer des interférences dans les communications radio. Cependant, il n'y a aucune garantie que des interférences ne se produiront pas dans une installation particulière. Si cet équipement provoque des interférences nuisibles à la réception radio ou de télévision, ce qui peut être déterminé en allumant et éteignant l'équipement, l'utilisateur est encouragé à essayer de corriger l'interférence par une ou plusieurs des mesures suivantes:

- Réorienter ou déplacer l'antenne de réception.
- Augmenter La distance entre l'équipement et le récepteur.
- Brancher l'équipement dans une prise sur un circuit différent de celui sur lequel est branché le récepteur.
- Consulter le revendeur ou un technicien radio/TV expérimenté.

Industrie Canada (IC)

ICES-003 Avis NMB-003, Classe B. Cet appareil numérique de la classe B est conforme à la norme NMB-003 du Canada.

Conformité Réglementaire au EU

Le produit est testé et conforme aux spécifications du marquage CE.

INTRODUCTION

What Is RackLink?

RackLink is a suite of AV system monitoring and power management products that allow local and remotely located users to instantly control, view and manage connected systems in real-time via the web, or through any Control System that supports IP or RS-232 communication.

Providing both individual outlet control and dry contact output control plus a suite of power monitoring and alerting capabilities the product suite includes 1RU rackmount products (15A and 20A) and compact 0RU in-line modular products that can be mounted in no-man's land.

RackLink Key Features:

- Remote reboot of connected equipment
- Auto-Ping feature for automatic remote reboot (or e-mail status notification) of equipment
- Integrated sequencing (model specific)
- Emergency power off (model specific)
- Power monitoring and logging
- Temperature monitoring and logging
- Individual outlet control is supported locally and remotely via the web or connected control system
- Multiple dry contact closure outputs can be controlled remotely via the web or connected control system
- Set and be alerted by e-mail to key threshold deviations (e.g. over current/under voltage/over temp)
- Open platform communications protocol provides seamless integration with Crestron, AMX and any IP or RS-232 based control system
- Mobile applications available for iPhone and Android

SYSTEM REQUIREMENTS

- Windows XP or greater with .Net 4.0 Framework.
- Windows Explorer Version 7 or higher.
- MAC OS X 10.6 or higher.
- DDNS Server Requirements (Optional): If you have an Internet line that has an address that remains the same (static), configure a port on your firewall to allow pass-through traffic to the RackLink device. Please see your router's instructions on opening ports. If you do not have a static IP address, you must first setup a method of the address change such as using a DDNS service. Once completed, follow those same instructions as if you had a static address and open a port on your router to allow traffic to pass-through.

RS-232 CONNECTION PINOUTS

NOTE: The DB9 port on the RackLink module is male. A Female-To-Female null modem cable is required.

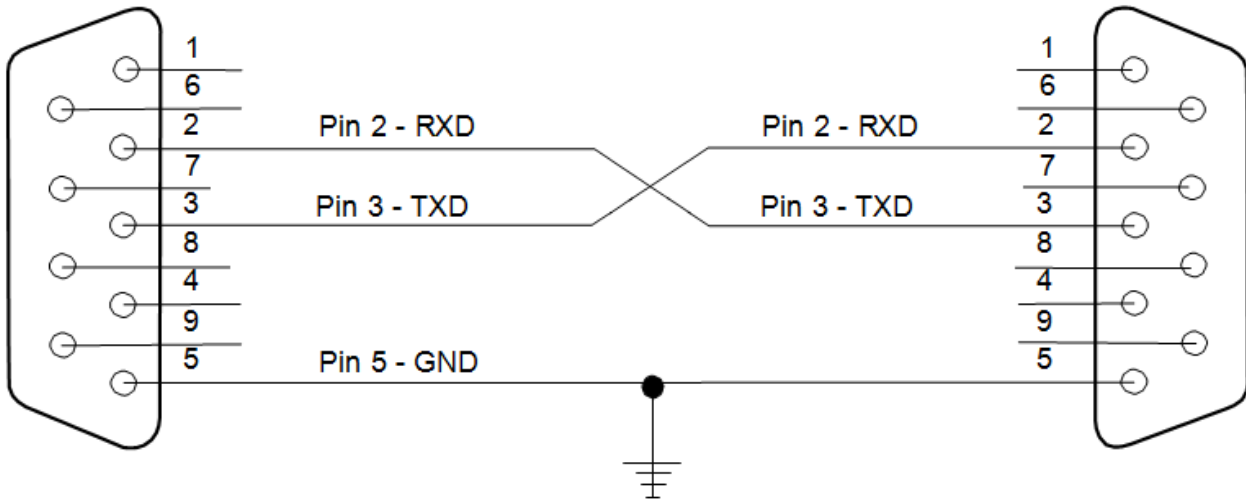

RackLink™ DEVICE DISCOVERY

There are two ways to discover your RackLink device. Using the Device Discovery software, or with the Device Discovery provided with the mobile application.

- **Software Installation:** By default the Device Discovery software will look for a DHCP server. The default IP address for the RackLink device is 192.168.1.200.
- For the mobile application to discover the RackLink device, the device and mobile phone must be on the same network.

NOTE: In order for the RackLink Device Discovery software to find your RackLink module. The PC where the software resides must be on the same subnet as the RackLink module. (See I-00472 for setting up RackLink via the RS-232 port). You may need to disable your Windows firewall if you cannot discover your RackLink device.

- 1) Access www.middleatlantic.com.
- 2) Download and run the RackLink Device Discovery **setup.exe** file.
The Device Discovery Setup dialog box appears.
- 3) Click **Next**.

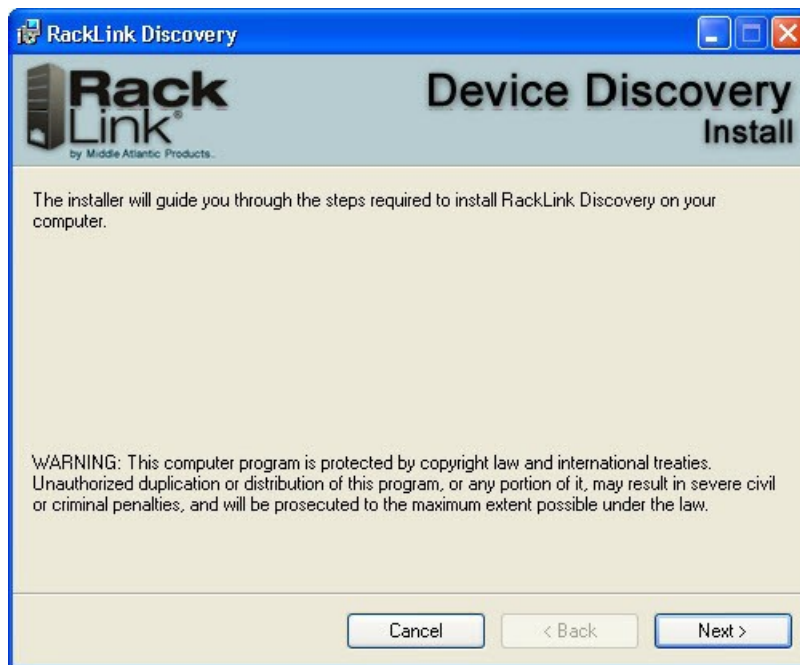

- 4) Click **Next**.
If desired, click Browse to change the installation location.

The default installation path is
C:\Program Files\Middle AtlanticProducts\RackLink Discovery\

To check disk space availability, you can click **Disk Cost**.
You can also install RackLink Discovery for everyone, or just the installer of the software.

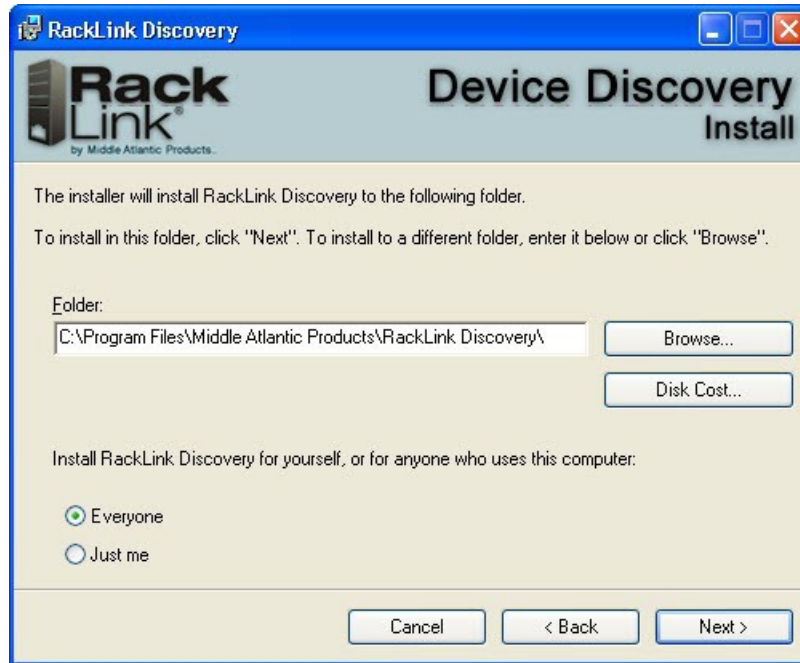

- 5) Click **Next** to begin the installation.

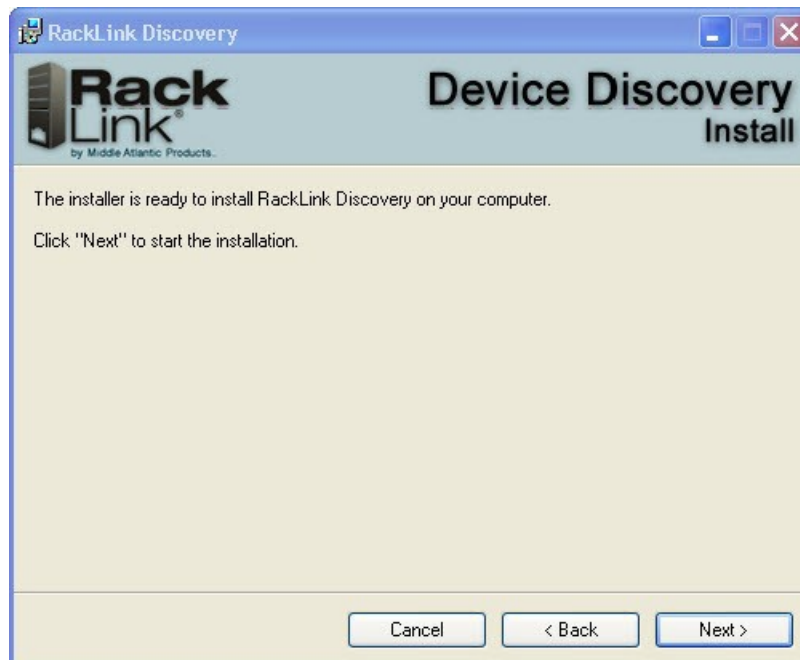

- 6) Click **Close** to exit. The default setting is to launch the RackLink Discovery tool. Uncheck the **Launch RackLink Discovery** checkbox if you do not want to automatically launch the tool.

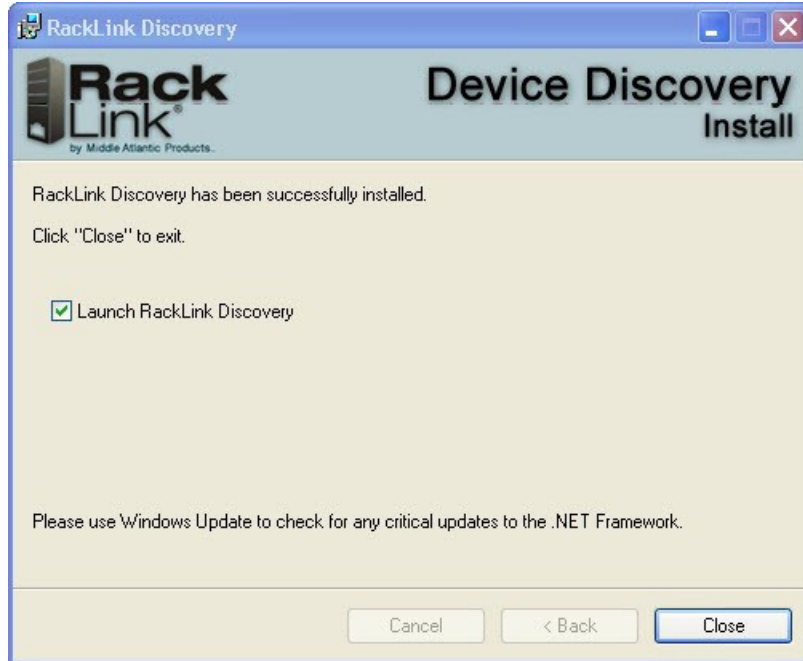

- 7) The RackLink Discover Tool will automatically discover all RackLink devices on the subnet you are connected to. You can also click **Discover** to search for RackLink devices added after the initial discovery. By default, the RackLink device is set for DHCP. You can identify each device by the MAC address or IP address.

NOTE: You may need to disable your Windows firewall if you cannot discover your RackLink device.



MAC RackLink™ DEVICE DISCOVERY

There are two ways to discover your RackLink device. Using the Device Discovery software, or with the Device Discovery provided with the mobile application.

- **Software Installation:** By default the Device Discovery software will look for a DHCP server. The default IP address for the RackLink device is 192.168.1.200.
- For the mobile application to discover the RackLink device, the device and mobile phone must be on the same network.

NOTE: In order for the RackLink Device Discovery software to find your RackLink module. The computer where the software resides must be on the same subnet as the RackLink module. (See I-00472 for setting up RackLink via the RS-232 port). You may need to disable your firewall if you cannot discover your RackLink device.

- 1) Access www.middleatlantic.com.
- 2) Download and run the **RackLinkDiscovery.pkg** file.
The Device Discovery Setup dialog box appears.
- 3) Click **Continue**.

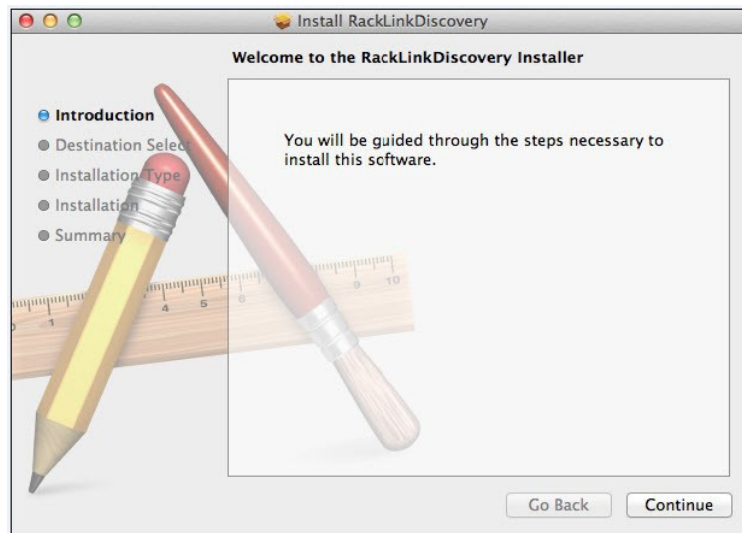

- 4) If desired, the installation destination can be selected here. Click **Continue**.

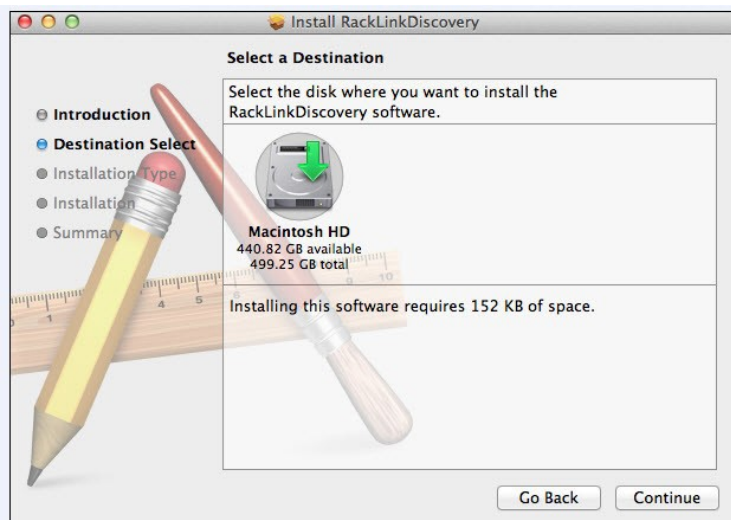

5) Click **Install** to begin the installation. If desired, you may change your Destination or the Installation Type/Location.

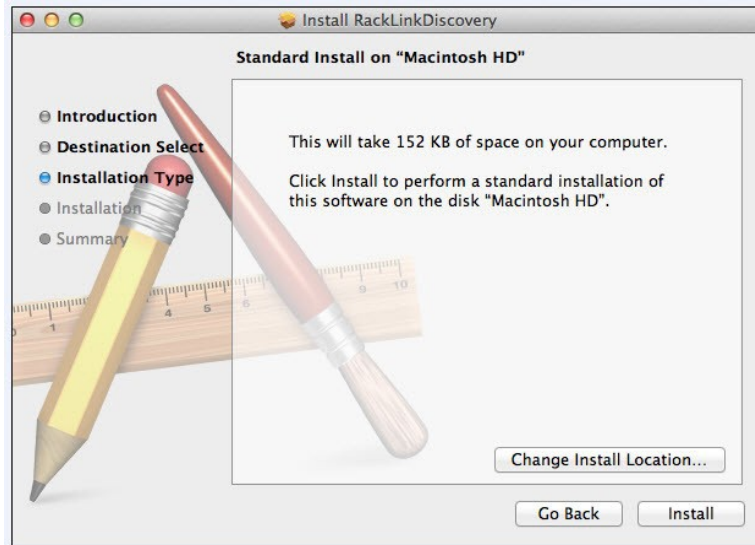

6) Click Close to exit after the installation was successful.

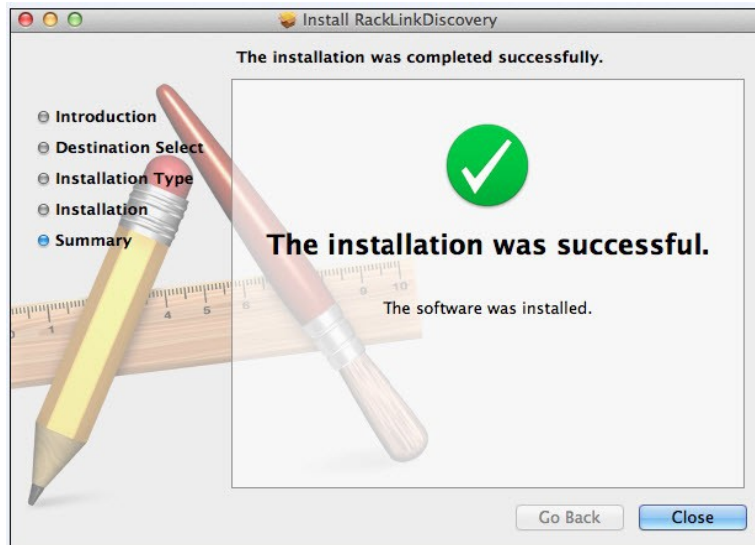

7) Navigate to **Applications** via the **Finder** to launch the RackLink Discovery application.

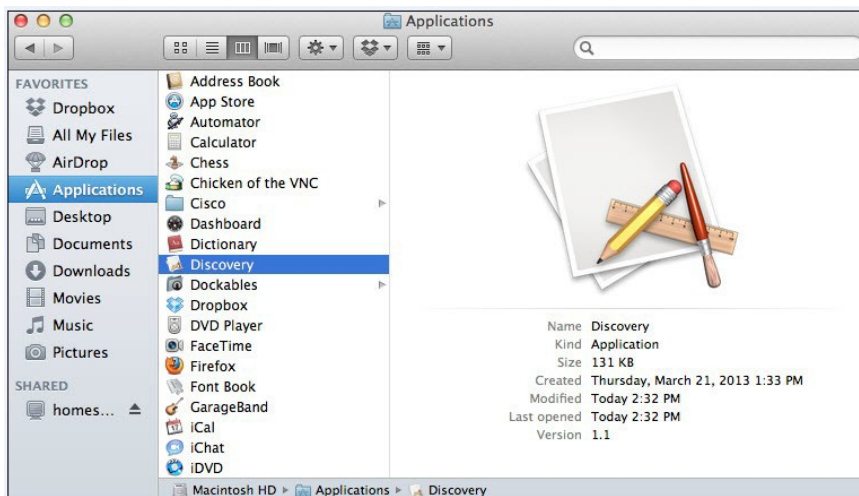

- 8) The RackLink Device Discover Tool will discover all RackLink devices on the subnet you are connected to. By default, the RackLink device is set for DHCP. You can identify each device by the MAC address or IP address.

NOTE: You may need to disable your firewall if you cannot discover your RackLink device.

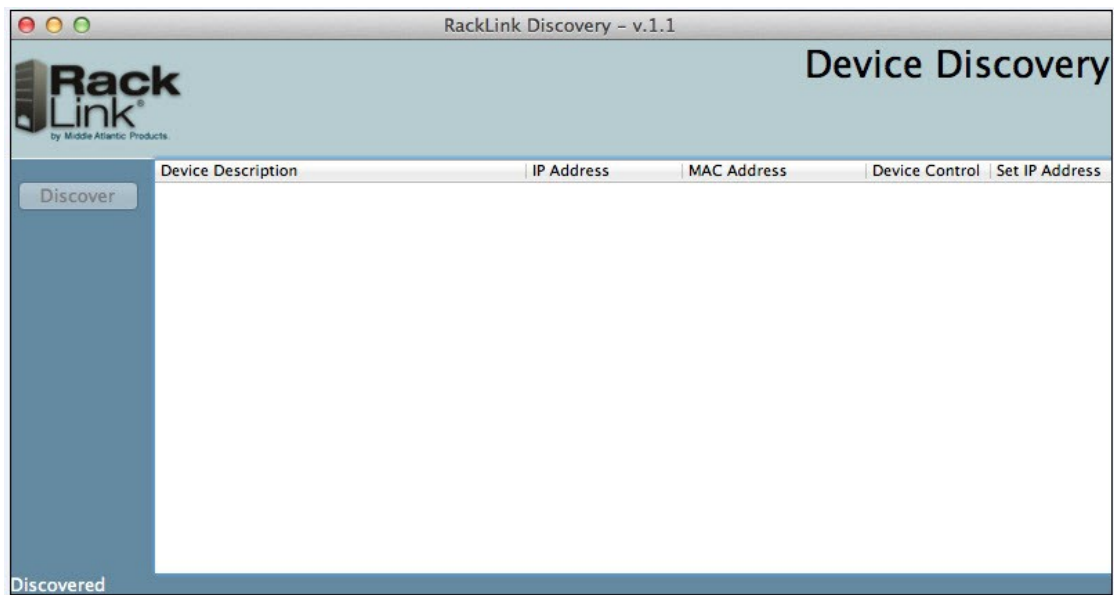

DEVICE CONTROL

- 1) After launching your RackLink Device Discovery program, the tool automatically discovers all RackLink devices on the subnet to which you are connected.

Use the Discover button to refresh the screen and discover any newly connected RackLink devices. By default, the RackLink device is set for DHCP. You can identify each device by the MAC address or IP address.

NOTE: You may need to disable your Windows firewall to discover your RackLink device.

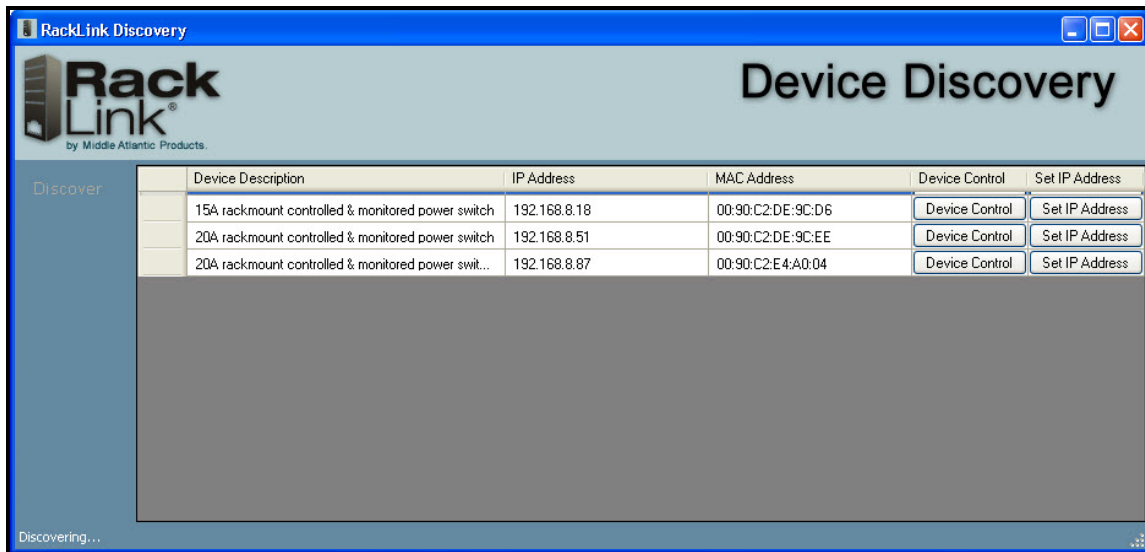

- 2) Click Device Control to access the browser-based interface for a specific device. The system prompts you for a username and password.



NOTE:

- To log in with the administrator account, the default credentials are Username: **admin** Password: **admin**.
- To log in with the user account, the default credentials are Username: **user** Password: **user**.

After logging in for the first time, the system forces you to change the default passwords for the administrator, user, and control system accounts for security purposes. For more information, see "User Interface Operation – Home Page" on page 19.

- 3) You may also change the IP settings by clicking on **Set IP Address** and un-checking **Use DHCP**. You will be prompted to enter your login credentials. You must be logged in as an **admin** to change the IP settings.



A dialog box titled "Credentials" with a blue header and a close button in the top right corner. The text "Enter your RackLink credentials." is centered. Below it are two input fields: "Username:" and "Password:". At the bottom are two buttons: "Cancel" and "Login".

- 4) Having successfully authenticated, you can now set the device's IP Address, Subnet Mask, Gateway, and DNS Server. Uncheck the 'DHCP' check box before making changes. After making changes, click **Apply** when completed. These settings are now the static settings for your RackLink device. You can access the web-based interface by typing the IP address in the address bar or by clicking **discover** on the discovery tool.



An "IP Settings" dialog box with a blue header and a close button. The "DHCP" checkbox is checked. Below it are four input fields: "IP Address: 192 . 168 . 8 . 39", "Subnet Mask: 255 . 255 . 255 . 0", "Gateway: 192 . 168 . 8 . 1", and "DNS Server: 192 . 168 . 5 . 120". At the bottom are "Apply" and "Cancel" buttons.

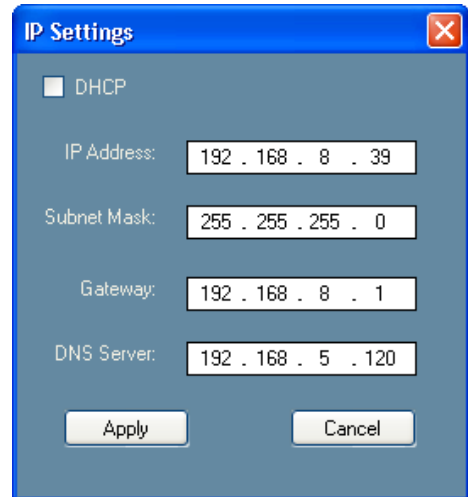

An "IP Settings" dialog box with a blue header and a close button. The "DHCP" checkbox is unchecked. Below it are four input fields: "IP Address: 192 . 168 . 8 . 39", "Subnet Mask: 255 . 255 . 255 . 0", "Gateway: 192 . 168 . 8 . 1", and "DNS Server: 192 . 168 . 5 . 120". At the bottom are "Apply" and "Cancel" buttons.

USER INTERFACE OPERATION - HOME PAGE

Logging in to the User Interface:

- 1) Install and launch your RackLink Discovery software and connect to a RackLink device.
For more information, see “RackLink Device Discovery” on page 11 or “MAC RackLink Device Discovery” on page 14.
The RackLink device prompts you for credentials.



The default names and passwords for the Administrator, User, and Control Systems accounts, respectively, on your RackLink device are as follows:

Administrator Account	User Account	Control System Account
Username: <code>admin</code>	Username: <code>user</code>	Username: <code>user</code>
Password: <code>admin</code>	Password: <code>user</code>	Password: <code>password</code>

After logging in for the first time, the system forces you to change the default passwords for the administrator, user, and control system accounts for security purposes.

NOTE:

- Log in for the first time using the administrator account in order to change the passwords for all of the accounts.
- External devices access your RackLink's serial API via the Control System account. This account is not used to access the browser-based interface.

- 2) Enter the credentials for the account you wish to use.
- 3) Click **Login**.
The Dashboard appears.

NOTE: The number of outlets and dry contacts are model specific. For more information, see “Sequencing Models Home Page” on page 22.

RackLink™
by Middle Atlantic Products

RLNK-SW715R Model #: RLNK-SW715R

My Device
Logs
Setup (Admin Only)
Close

Current Readings

Input Voltage (RMS)	Input Voltage (Peak)	Load Current (RMS)	Load Current (Peak)
118 VAC	123 VAC	0.2 A	0.3 A
Watts	Power Factor	Kilo Watt Hours	Thermal Load (BTU)
17 W	0.7	0.4 kWh Reset	60 BTUs
Temperature			
74° F			

Outlets

Number	Name	Status	Control	Cycle Delay (sec.)
				<input type="text" value="3"/>
1.	OUTLET 1	ON	Not Controllable	Not Controllable
2.	OUTLET 2	ON	Not Controllable	Not Controllable
3.	OUTLET 3	ON	<input type="button" value="ON"/> <input type="button" value="OFF"/>	<input type="button" value="Cycle"/>
4.	OUTLET 4	ON	<input type="button" value="ON"/> <input type="button" value="OFF"/>	<input type="button" value="Cycle"/>
5.	OUTLET 5	ON	<input type="button" value="ON"/> <input type="button" value="OFF"/>	<input type="button" value="Cycle"/>
6.	OUTLET 6	ON	<input type="button" value="ON"/> <input type="button" value="OFF"/>	<input type="button" value="Cycle"/>
7.	OUTLET 7	ON	<input type="button" value="ON"/> <input type="button" value="OFF"/>	<input type="button" value="Cycle"/>

Dry Contacts

Number	Name	Status	Control	Cycle Delay (sec.)
				<input type="text" value="3"/>
A.	CONTACT 1	OPEN	<input type="button" value="OPEN"/> <input type="button" value="CLOSE"/>	<input type="button" value="Cycle"/>
B.	CONTACT 2	OPEN	<input type="button" value="OPEN"/> <input type="button" value="CLOSE"/>	<input type="button" value="Cycle"/>
C.	CONTACT 3	OPEN	<input type="button" value="OPEN"/> <input type="button" value="CLOSE"/>	<input type="button" value="Cycle"/>
D.	CONTACT 4	OPEN	<input type="button" value="OPEN"/> <input type="button" value="CLOSE"/>	<input type="button" value="Cycle"/>
E.	Surge Status	PROTECTED	Not Controllable	Not Controllable

Processor Firmware - v 0.62 - 06171108

www.MIDDLEATLANTIC.COM

My Device Functions/Options:

- The top left corner contains the Device Name. This can be set/changed under the **setup>device settings tab**. The default name is the device model. The model number is listed on the right hand side of the screen. This cannot be changed.
- Device image as shown from the back of the unit (RLNK-SW715R shown).

- **Current Readings:**
 - Input Voltage (RMS)
 - Input Voltage (Peak)
 - Load Current (RMS)
 - Load Current (Peak)
 - Watts
 - Power Factor
 - Kilowatt Hours (Can be reset)
 - Thermal Load (BTU)
 - Temperature
- **Outlets:**
 - **Number:** Outlet number from left to right.
 - **Name:** The name can be changed by clicking on the **current name**. Once changed, you can click **save or cancel**.
 - **Status:** Tells you if the outlet is on, off, or rebooting.
 - **Control:** For controllable outlets, you can manually turn them on/off. Default status is on.
 - **Cycle:** This will cycle the outlet power one time only when the outlet is on. The cycle delay can be set for **1 - 999 seconds**, 3 seconds is the default. If during the cycled delay period a new command is received for that outlet, it will supersede the cycle command.
- **Dry Contacts:**
 - **Number:** Dry contact number/letter from left to right.
 - **Name:** The name can be changed by clicking on the **current name**. Once changed, you can click **save or cancel**.
 - **Status:** Tells you if the dry contact is on, off, or rebooting. If you have a unit with surge protection there will be one dry contact that is for notification if the surge protection is compromised.
 - **Control:** Allows user to open or close dry contacts, default status is closed.
 - **Cycle:** This will cycle the dry contact one time whether the dry contact is open or closed. The cycle delay can be set for **1 - 999 seconds**, 3 seconds is the default. If during the cycled delay period a new command is received for that dry contact, it will supersede the cycle command.
- **Processor Firmware:** This displays the current firmware version with the manufacturing code.

SEQUENCING MODELS - HOME PAGE

Sequence Functionality

- If outlets are checked in the sequence control section, this will override startup default. Refer to the sequencing section on the 'Device Settings' page, 'Initial Outlet Contact State' section.
- Dry contact 'C' is dedicated sequence status notification.

Rack Link
by Middle Atlantic Products.

RLNK-SW815R-SP Model #: RLNK-SW815R-SP

My Device
Logs
Setup (Admin Only)
Close

Current Readings

Input Voltage (RMS) 120 VAC	Input Voltage (Peak) 120 VAC	Load Current (RMS) 0 A	Load Current (Peak) 0.1 A
Watts 8 W	Power Factor 0.7	Kilo Watt Hours 0 KWh Reset	Thermal Load (BTU) 28 BTUs
Temperature 78° F			

Sequence Control: Rear Outlets

Rear Outlets	Status	Control	Delay (sec.)
<input checked="" type="checkbox"/> 2 <input checked="" type="checkbox"/> 3 <input checked="" type="checkbox"/> 4 <input checked="" type="checkbox"/> 5 <input checked="" type="checkbox"/> 6 <input checked="" type="checkbox"/> 7 <input checked="" type="checkbox"/> 8	Not Sequenced	<input type="button" value="ON"/> <input type="button" value="OFF"/>	<input type="text" value="1"/>

Manual Control: All Outlets

Number	Name	Status	Control	Cycle Delay (sec.)
				<input type="text" value="3"/>
1.	Add description	ON	<input type="button" value="ON"/> <input type="button" value="OFF"/>	<input type="button" value="Cycle"/>
2.	Add description	ON	<input type="button" value="ON"/> <input type="button" value="OFF"/>	<input type="button" value="Cycle"/>
3.	Add description	ON	<input type="button" value="ON"/> <input type="button" value="OFF"/>	<input type="button" value="Cycle"/>
4.	Add description	ON	<input type="button" value="ON"/> <input type="button" value="OFF"/>	<input type="button" value="Cycle"/>
5.	Add description	ON	<input type="button" value="ON"/> <input type="button" value="OFF"/>	<input type="button" value="Cycle"/>
6.	Add description	ON	<input type="button" value="ON"/> <input type="button" value="OFF"/>	<input type="button" value="Cycle"/>
7.	Add description	ON	<input type="button" value="ON"/> <input type="button" value="OFF"/>	<input type="button" value="Cycle"/>
8.	Add description	ON	<input type="button" value="ON"/> <input type="button" value="OFF"/>	<input type="button" value="Cycle"/>

Dry Contacts

Number	Name	Status	Control	Cycle Delay (sec.)
				<input type="text" value="3"/>
A.	Add description	OPEN	<input type="button" value="OPEN"/> <input type="button" value="CLOSE"/>	<input type="button" value="Cycle"/>
B.	Add description	OPEN	<input type="button" value="OPEN"/> <input type="button" value="CLOSE"/>	<input type="button" value="Cycle"/>
C.	Sequence Status Notification	CLOSED	Not Controllable	Not Controllable

Processor Firmware - v 2.01 - 03161206

www.MIDDLEATLANTIC.COM

- **Sequence Control: Rear Outlets**
 - **Rear Outlets:** Select/deselect the rear outlets to be sequenced. The lower number outlet will be the first to sequence up, the higher numbered outlet will be the first to sequence down.
 - **Status:** This field will show the current sequence state. If sequencing is not enabled, the field will read 'Not Sequenced'. If sequencing has not been initiated or any sequenced outlet has changed state, status will read 'Not Sequenced'. Otherwise, you will see one of the following messages.
 - Sequence ON in Progress
 - Sequence ON Complete
 - Sequence OFF in Progress
 - Sequence OFF Complete
 - **Control:** User selectable on/off buttons will enable/disable sequencing. The on/off buttons operate so that it is possible to select 'Sequence ON/OFF' multiple times without having to first select 'Sequence OFF/ON'.
 - **Delay (in seconds):** This is the delay between outlets sequencing on/off. The set delay is the same for all sequenced outlets. The delay can be set from 0 – 999 seconds.
- **Dry Contacts:** Sequence Status Notification
 - Non-Controllable Dry Contact Switch: Open by default, closed upon sequence complete. Reopen on sequence off complete.

NOTE: If manually controlling a previously sequenced outlet (e.g. turning off an outlet that was sequenced on) will not cause the contact to change state.

LOGS

The screenshot shows the Rack Link web interface for device RLNK-SW715R. The interface includes a sidebar with navigation options (My Device, Logs, Setup (Admin Only), Close), a main content area with date/time selection and a list of checked variables (Input Voltage (RMS), Load Current (RMS), Watts, Power Factor, Temperature, Thermal Load (BTUs)), and a table of log entries.

Timestamp	Input Voltage (RMS)	Load Current (RMS)	Watts	Power Factor	Temperature	Thermal Load
09/06/2011 15:45:57	121	00.3	0017	0.7	074	0060.7
09/06/2011 15:50:34	121	00.3	0017	0.7	074	0059.6
09/06/2011 15:55:24	121	00.3	0017	0.7	073	0060.7
09/06/2011 16:01:08	121	00.3	0017	0.7	073	0059.6
09/06/2011 16:02:22	120	00.3	0017	0.7	073	0060.7
09/06/2011 16:05:03	120	00.3	0017	0.7	074	0060.7
09/06/2011 16:10:23	120	00.3	0017	0.7	074	0060.7
09/06/2011 16:15:42	120	00.3	0017	0.7	074	0060.7
09/06/2011 16:19:52	120	00.3	0017	0.7	074	0060.7
09/06/2011 16:24:46	120	00.3	0017	0.7	074	0060.7

Logging: Logs provide you with the ability to view historical data. You can set the start and end date/time manually. The factory default is set to capture 24 hours of data. The log saves up to 2000 entries. The first entry in will be the first entry deleted.

- You can refresh the view by clicking on the **Refresh** button.
- Click **Save As** and the log file can be saved as a **.csv file**.

The following information can be displayed by clicking the check box next to the option.

- Input Voltage (RMS)
- Load Current (RMS)
- Watts
- Power Factor
- Temperature
- Thermal Load (BTUs)

NOTE: Reason codes and meanings are not logged on the interface, but are logged in the .csv file.

Logging Operation:

- If all variables are within the tolerance range, a record will be logged every 5 minutes.
- If a monitored value is out of tolerance range, the following will take place.
 - The record will log immediately upon event occurrence and when the recovery takes place. This will also generate an e-mail alert if the device is setup to perform that function.

- During the out of tolerance period, a log entry will continue to populate every 5 minutes, store an additional record, and issue e-mail alert (if alert is setup) during the following situations.
 - 🔔 Input voltage changes +/- 2V
 - 🔔 Load current changes +/- .2A
 - 🔔 Temperature changes +/- 2°
- When you click on **Save As** and save the log file, you can also view reason codes, and the meanings of the reason code next to the log entry. The following reason codes and meanings are listed below.
The reason code is 1st and the meaning is 2nd.
 - 🔔 0 – Normal Event
 - 🔔 1 – Over Voltage
 - 🔔 2 – Under Voltage
 - 🔔 3 – Over Current
 - 🔔 4 – Under Current
 - 🔔 5 – Over Temperature
 - 🔔 6 – Under Temperature
 - 🔔 7 – Surge Fault
 - 🔔 8 – Auto Ping Fault
 - 🔔 9 – RS-232 Ping Fail

DEVICE SETTINGS

General Settings

Device Name: RLNK-SW815R-SP

Account Name/Number:

Device Description: 15A rackmount controlled & monitored power switch. Series surge.

Local Outlet Control: ENABLED

Initial Outlet/Contact State: ON/OPEN

Update Firmware: Current Version: 2.01
[Upload a new version](#)

Sequencing

Sequence on Power Up: ENABLED

Sequence Input Control Type: Normally Open / Maintained

Sequence Notification: Act as next step

Emergency Power Off

EPO Input Control Type: Normally Open / Maintained

Recovery: Automatic

Apply Restore Factory Defaults

Processor Firmware - v 2.01 - 03161206

SEQUENCING MODELS ONLY (SEE NEXT PAGE)

General Settings:

- **Device Name:** The name that will be shown in the top left corner on every page.
- **Account Name/Number:** User defined field for reference.
- **Device Description:** This description will be shown in the RackLink Discovery Tool.
- **Initial Outlet/Contact State:** ON/OPEN is the factory default setting for the outlet(s) and dry contact(s). When doing a firmware upgrade the outlet(s)/dry contact(s) state will default to the setting There are three settings:
 - **Remember prior state** - The outlet(s)/dry contact(s) will remain in the prior state.
 - **OFF/OPEN** - The outlet(s) will default to on, the dry contact(s) will default to open.
 - **ON/OPEN** - The outlet(s) will default to on, the dry contact(s) will default to open (default setting).

UPDATE FIRMWARE: Shows the current version of firmware. Click the Upload a new version link to browse and upload the latest version. Middle Atlantic Products recommends updating your device to the latest firmware version. Download the latest firmware updates at www.middleatlantic.com or contact support at 1-800-266-7225.

Sequencing:

- **Sequence on Power Up:** ENABLED/DISABLED. Default setting is ENABLED.
- **Sequence Input Control Type:**
 - Maintained; Normally Open
 - Maintained; Normally Closed
 - Momentary; Normally Open
 - Momentary; Normally Closed
- **Sequence Notification:**
 - Act as next step (default): Dry Contact C will **'close'** after the highest numbered outlet has been powered on. The dry contact will **'open'** immediately following a **'sequence off'** command.
 - Sequence status complete: Upon completion of **'sequence on'** Dry Contact C will close, when the highest numbered outlet in the sequence profile has powered **'on'** following a change of state in the Dry Contact input, or if executed via the GUI.

Emergency Power Off: Normally Open/Maintained (cannot be changed)

- **Recovery: Automatic (default)** If Dry Contact input E state is **'closed'** the RackLink unit will respond according to the following.
 - **'Device is in emergency power off condition'** notification removed from **'my device'** tab.
 - Local outlet control is disabled.
 - GUI outlet control disabled.
 - Serial communication outlet and sequencing control disabled.
 - Dry Contact Input D (Sequence ON/OFF) is disabled.
 - Dry Contact Output C (Sequence Status) set to open.
 - Entered Emergency Power Off Condition e-mail is issued (if enabled).
 - All controlled outlets turned **'off'** immediately; and concurrently.
 - Rapid **'sequence off'** initiated. The highest numbered outlet in the sequence profile, through the lowest numbered outlet in the sequence profile.
 - ⚠ Highest numbered outlet turns off immediately.
 - ⚠ Minimum delay between each step.
- **Hard Reset Required:** The device will remain in EPO mode pending a hard reboot.

TCP/IP SETTINGS

The screenshot shows the RackLink web interface for a device with model number RLNK-SW715R. The interface is divided into a left sidebar with navigation options and a main content area. The sidebar includes: My Device, Device Settings, TCP/IP Settings (highlighted), Notification, Alert Thresholds, Auto Ping Settings, Passwords, Restore Defaults, and Close. The main content area is titled 'TCP/IP Settings' and contains two sections: 'TCP/IP Settings' and 'NTP Settings'. The 'TCP/IP Settings' section includes: MAC Address: 00:90:C2:DE:9C:D6; USE DHCP: checked; IP Address: 192.168.8.74; Subnet Mask: 255.255.255.0; Gateway: 192.168.8.1; Primary DNS: 192.168.5.120; Secondary DNS (Optional): 192.168.5.121; HTTP Port: 80. The 'NTP Settings' section includes: Use NTP: checked; NTP Server 1: 0.north-america.pool.ntp.org; NTP Server 2: 1.north-america.pool.ntp.org; Date: 10/12/11; Time: 07:50 AM; Time Zone: Eastern Standard Time (GMT-5:00); Daylight Savings Time: unchecked. At the bottom right of the main content area are 'Apply' and 'Restore Factory Defaults' buttons. The footer of the interface shows 'Processor Firmware - v 0.73 - 10051108' and the RackLink logo with the website 'www.MIDDLEATLANTIC.COM'.

TCP/IP Settings:

- **MAC Address:** Unique MAC Address to your specific unit.
- **USE DHCP:** If checked the device will use a DHCP server to set all IP address settings.
- **IP Address Settings:**
 - Device IP Address
 - Subnet Mask
 - Gateway
 - Primary DNS
 - Secondary DNS (Optional)
 - HTTP Port: 80 (Default) - You cannot choose a port that is already in use. The used ports are 7 (ICMP/Ping), 54632 (Discovery), and 60000 (Control Protocol). If you choose any of these ports the system will not change the port of the HTTP Server.

- **NTP Settings:** Network Time Protocol.
 - **Use NTP** – Check this to **enable** the usage of the Network Time Protocol.
 - **NTP Server 1:** Set a NTP server of your choice (Default is 0.north-america.pool.ntp.org).
 - **NTP Server 2:** Set a NTP server of your choice (Default is 1.north-america.pool.ntp.org).
 - **Date/Time:** The date and time when the entry was made.
 - **Time Zone:** Drop down menu for setting to the desired time zone.
 - **Daylight Savings Time:** Check to recognize daylight savings time.
- Click **apply** for the changes to take effect.

NOTIFICATION

RackLink
by Middle Atlantic Products.

RLNK-SW815R-SP Model #: RLNK-SW815R-SP

Notifications

Email Alerts

	No Response	Recovery	Threshold	EPO
Alert Recipient: <input type="text"/>	<input type="checkbox"/>	<input type="checkbox"/>	<input type="checkbox"/>	<input type="checkbox"/>
Alert Recipient: <input type="text"/>	<input type="checkbox"/>	<input type="checkbox"/>	<input type="checkbox"/>	<input type="checkbox"/>
Alert Recipient: <input type="text"/>	<input type="checkbox"/>	<input type="checkbox"/>	<input type="checkbox"/>	<input type="checkbox"/>
Alert Recipient: <input type="text"/>	<input type="checkbox"/>	<input type="checkbox"/>	<input type="checkbox"/>	<input type="checkbox"/>
Alert Recipient: <input type="text"/>	<input type="checkbox"/>	<input type="checkbox"/>	<input type="checkbox"/>	<input type="checkbox"/>

Mail Server

Server Name:

Server Port:

User Name:

Password:

Sender's Email Address:

Send Test Email:

Last Test Result:

Processor Firmware - v 2.01 - 03161206

Email Alerts:

- **Alert Recipients:** (five maximum) for **notification** of an auto ping no response, recovery from a threshold violation, and when a threshold has gone above or below assigned value.
- **No Response:** If checked, sends a notification if an auto ping IP address fails to respond.
- **Recovery:** If checked, sends a notification if a threshold violation has been reached.
- **Threshold:** If checked, sends a notification if a threshold violation has occurred.
- **EPO:** During and 'Emergency Power Off' situation, the 'Alert Recipient' will receive an e-mail notification.

Mail Server:

- **Server Name:** The name of the mail server you will be using.
- **Server Port:** Default port is 25.
- **User Name:** Login name for the mail server.
- **Password:** Password for logging into the mail server.
- **Sender's Email Address:** Email address that a notification will come from. Ensure the email is white-listed so that is not marked as spam and does not reach the intended recipient.
- **Send Test Email:** This option will send one test e-mail to ensure the e-mail alert system is operating properly
- Click **Apply** for the changes to take effect.

NOTE:

- Make sure the server name is fully qualified.
- Make sure the port is correct.
- Confirm the network does not block outbound traffic on the specified port.
- If the e-mail system requires authentication, populate the username and password text boxes.

ALERT THRESHOLDS

RackLink
by Middle Atlantic Products.

RLNK-SW415R-SP Model #: RLNK-SW415R-SP

Alert Thresholds

Current Readings

Input Voltage (RMS)	Input Voltage (Peak)	Load Current (RMS)	Load Current (Peak)
114 VAC	120 VAC	0 A	0.1 A
Watts	Power Factor	Kilo Watt Hours	Thermal Load (BTU)
4 W	0.5	0.1 kWh Reset	12 BTUs
Temperature			
81° F			

Input Voltage Alert Threshold

Low Voltage: (105V - 110V)
High Voltage: (123V - 128V)

Under & Over Voltage Actions

Turn Off All Outlets

Load Current Alert Threshold

Max: (0A - 20A)
Min: (0A - 20A)

Temperature Alert Threshold

Max:
Min:

Over Temperature Actions

	Action	Power Cycle Delay Period (1-999 seconds)
Outlet:	<input type="text" value="3 - Add description"/> <input type="button" value="v"/> <input type="text" value="None (default)"/> <input type="button" value="v"/>	<input type="text" value="3"/>
Dry Contact:	<input type="text" value="A - Add description"/> <input type="button" value="v"/> <input type="text" value="None (default)"/> <input type="button" value="v"/>	

Processor Firmware - v 0.07 - 03021206

www.MIDDLEATLANTIC.COM

- **Current Readings:** Shows the current reading that is also shown on the home page.
- **Input Voltage Alert Threshold:** Allows the user to set the high and low voltage alert thresholds.
 - **Low Voltage:** thresholds can be set from **105V - 110V**.
 - **High Voltage:** thresholds can be set from **123V - 128V**.

- **Under/Over Voltage Actions:** If checked, all outlets will be turned off immediately if an under/over voltage condition takes place.
- **Load Current Alert Threshold:** Allows the user to set the max and min current alert thresholds.
 - **Max Current:** thresholds can be set from **0A - 15A** (for 15A models) **0A - 20A** (for 20A models).
 - **Min Current:** thresholds can be set from **0A - 15A** (for 15A models) **0A - 20A** (for 20A models).
- **Temperature Alert Threshold:** This threshold has no upper or lower limits.
- **Over Temperature Actions:** When an over temperature is reached, you can perform the following actions on the controlled outlet(s) and on the dry contact(s). Only one action per outlet or dry contact can be performed at a time.

OUTLET ACTIONS

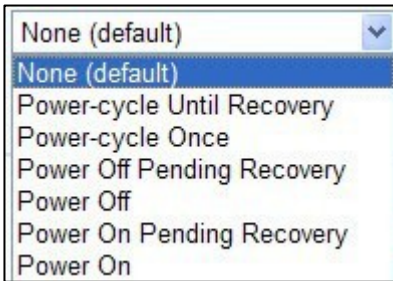

DRY CONTACT ACTIONS

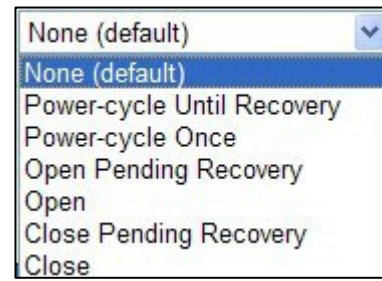

- Click **apply** for the changes to take effect.
 - **Please note the following:** You cannot use the same outlet/dry contact for both Auto Ping and Over Temperature Actions. For example, if you set Outlet 3 to Power Cycle until Recovery for Auto Ping, that outlet will not show up in the dropdown selection for Over Temperature. The opposite is also true. If you set Outlet 3 to be power on for Over Temperature, it will not show up in the dropdown selection for Auto Ping.
 - On the two outlet in-line models (RLNK-SW215-NS and RLNK-SW220-NS), there is only one outlet/dry contact available. You will only be able to set an outlet/contact response for Auto Ping or Over Temperature Actions, but not both.
- **Power Cycle Delay Period:** This can be set for **1 - 999 seconds**. 3 seconds is the factory default
 - When an outlet is cycled until recovery from an Over Temperature Action, the outlet will be on, even if the previous state was off.

AUTO PING SETTINGS

RackLink
by Middle Atlantic Products

RLNK-SW815R-SP Model #: RLNK-SW815R-SP

Auto Ping

Auto Ping Settings

Current Status:

Enable Auto Ping:

IP Address To Ping: . . .

Frequency (sec.): (30-999 seconds)

Failures: (2-200)

Action on No Response to Auto Ping

	Action	Power Cycle Delay Period (1-999 seconds)
Sequence Outlets: <input type="checkbox"/>	Sequence Off	
Outlet: <input type="text" value="3 - Add description"/>	<input type="text" value="None (default)"/>	<input type="text" value="3"/>
Dry Contact: <input type="text" value="1 - Add description"/>	<input type="text" value="None (default)"/>	

Processor Firmware - v 2.01 - 03161206

NOTE: If the RackLink device does not have an active connection to a router/gateway, the Auto Ping actions for the outlets and/or dry contacts are disabled. You can however configure the actions if the Ethernet link is inactive.

Auto Ping Settings: Configure RackLink device to ping another network device and create actions if the device does not respond.

- **Current Status:** This should read **Communication Established** if the device configured with the auto ping address is communicating. If this reads **Communication Not Established**, the auto ping device is not recognized by the RackLink device.
- **Enable Auto Ping:** Check this box to enable auto ping.
- **IP Address To Ping:** Add the IP address that is to be auto pinged.
- **Frequency (in seconds):** How often, in seconds, your device will initiate an auto ping. This can be set from **30 - 999** seconds (the default is 30 seconds).
- **Retries:** The number of time your device will ping the preset address if no response is received. This can be set from **2 - 200** retries (the default is 3).

Action on Failure: When the device being auto pinged does not reply, you can perform the following actions on the controlled outlet(s) and on the dry contact(s). The actions will cease if/when the device being pinged replies.

- **Sequence Outlets:** Default action is to 'Sequence Off'. If check box selected existing 'Outlet' actions are to be disabled. Dry Contact Output actions remain as prior settings. This is a one-time action.

OUTLET ACTIONS

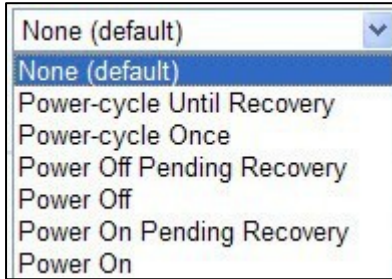

A dropdown menu with a blue header bar containing the text "None (default)" and a downward arrow. The menu is open, showing a list of options: "None (default)", "Power-cycle Until Recovery", "Power-cycle Once", "Power Off Pending Recovery", "Power Off", "Power On Pending Recovery", and "Power On". The "None (default)" option is highlighted in blue.

DRY CONTACT ACTIONS

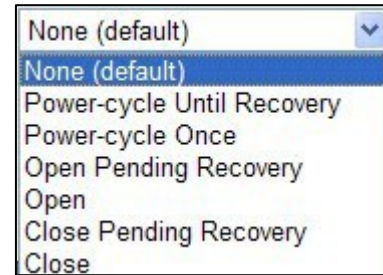

A dropdown menu with a blue header bar containing the text "None (default)" and a downward arrow. The menu is open, showing a list of options: "None (default)", "Power-cycle Until Recovery", "Power-cycle Once", "Open Pending Recovery", "Open", "Close Pending Recovery", and "Close". The "None (default)" option is highlighted in blue.

- Click **apply** for the changes to take effect.

PLEASE NOTE THE FOLLOWING: You cannot use the same outlet/dry contact for both Auto Ping and Over Temperature Actions. For example, if you set Outlet 3 to Power Cycle until Recovery for Auto Ping, that outlet will not show up in the dropdown selection for Over Temperature. The opposite is also true. If you set Outlet 3 to be power on for Over Temperature, it will not show up in the dropdown selection for Auto Ping.

On the two outlet in-line models (RLNK-SW215-NS and RLNK-SW220-NS), there is only one outlet/dry contact available. You will only be able to set an outlet/contact response for Auto Ping or Over Temperature Action, but not both.

- **Power Cycle Delay Period:** This can be set for **1 - 999** seconds. 3 seconds is the factory default
 - When an outlet is cycled until recovery from an Over Temperature Action, the outlet will be on, even if the previous state was off.

PASSWORDS

RackLink
by Middle Atlantic Products

RLNK-SW715R Model #: RLNK-SW715R

Passwords

User Access

New Password:

Confirm New Password:

Apply

Admin Access

New Password:

Confirm New Password:

Apply

Control Protocol RS-232 Password

New Password:

Confirm New Password:

Apply

Control Protocol TCP/IP Password

New Password:

Confirm New Password:

Apply

Processor Firmware - v 0.62 - 06171108

Passwords: If logged in as an administrator, you can change the passwords for the administrator and a user. If logged in as a user, you cannot make any changes to the settings. Click **Apply** when the new password is entered.

- **Default login/password:** For a user, it is **user/user**.
- **Default login/password:** For an admin it is **admin/admin**.
 - You can only change *passwords* not the login; the default login remains admin and user. If logged in as a user, you can click on **Setup tab**, and you will be prompted to login as an administrator.
- **RS-232 Control Protocol default login/password:** The default is **user/password**.
- **TCP/IP Control Protocol default login/password:** The default is **user/password**.
 - You can only change the *password* not the login; the default login remains user.

RESTORING DEFAULT SETTINGS

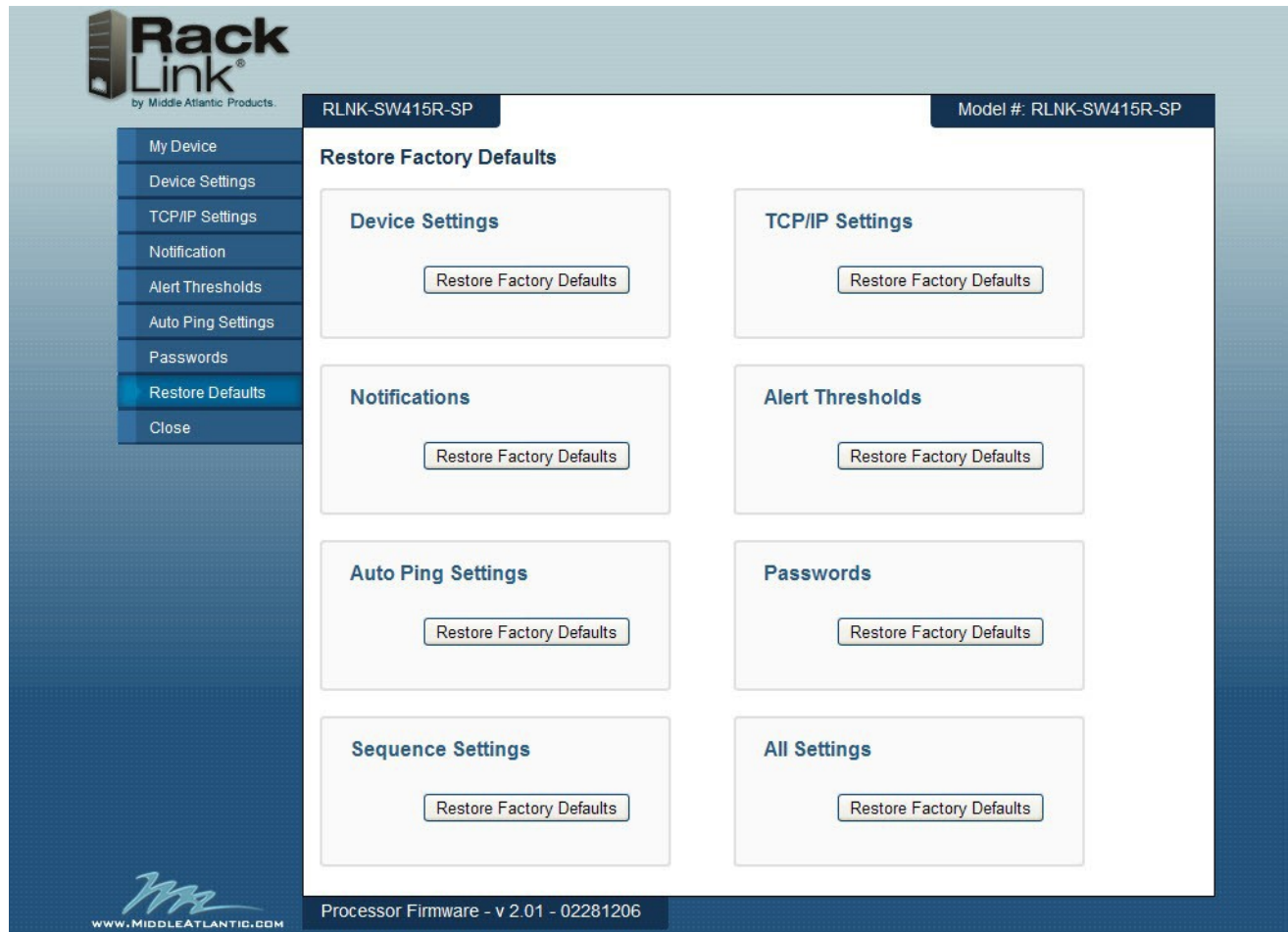

Restore Defaults: This allows you to restore the **factory default** settings for the following.

- Device Settings
- TCP/IP Settings
- Notifications
- Alert Thresholds
- Auto Ping Settings
- Passwords
- Sequence Settings (sequencing models only)
- All Settings (defaults all previously listed settings)
 - When you click on any of these options, you will be prompted to click **OK** or **Cancel**.

After resetting your device, the system forces you to change the default password for security purposes. For more information, see "User Interface Operation - Home Page" on page 19.

UPDATING FIRMWARE

Rack Link
by Middle Atlantic Products.

RLNK-SW415R-SP Model #: RLNK-SW415R-SP

Update Firmware

Step 1: Upload Firmware File

Current Firmware: RLNK-SW820R-SP v0.07

Get the Latest Firmware: [Firmware](#)

Upload New Firmware:

Step 2: Install Firmware

Last Firmware Uploaded: RLNK-SW820R-SP v0.07

Processor Firmware - v 0.07 - 03021206

- **Current Firmware:** Shows the current revision loaded into your device.
- **Get The Latest Firmware:** Click on this link to go to the MAP website to obtain the current version on firmware.
- **Upload New Firmware:** Click **browse** to locate the file. Once the file is located, click on **upload**.
 - You will see the following screen while the firmware is updating.

Rack Link
by Middle Atlantic Products.

RLNK-SW715R Model #: RLNK-SW715R

Update Firmware

Step 1: Upload Firmware File

 Updating firmware.

When firmware upload has completed click 'Install' to update your device.
NOTE THAT THE DEVICE WILL REBOOT AUTOMATICALLY AFTER FIRMWARE UPDATE. IT IS RECOMMENDED THAT CONNECTED DEVICES ARE POWERED DOWN PRIOR TO CLICKING 'INSTALL'

Processor Firmware - v 0.57 - 06171108

NOTE: The RackLink device will reboot automatically after the firmware update. It is highly recommended that all connected devices are powered down prior to clicking **Install**.

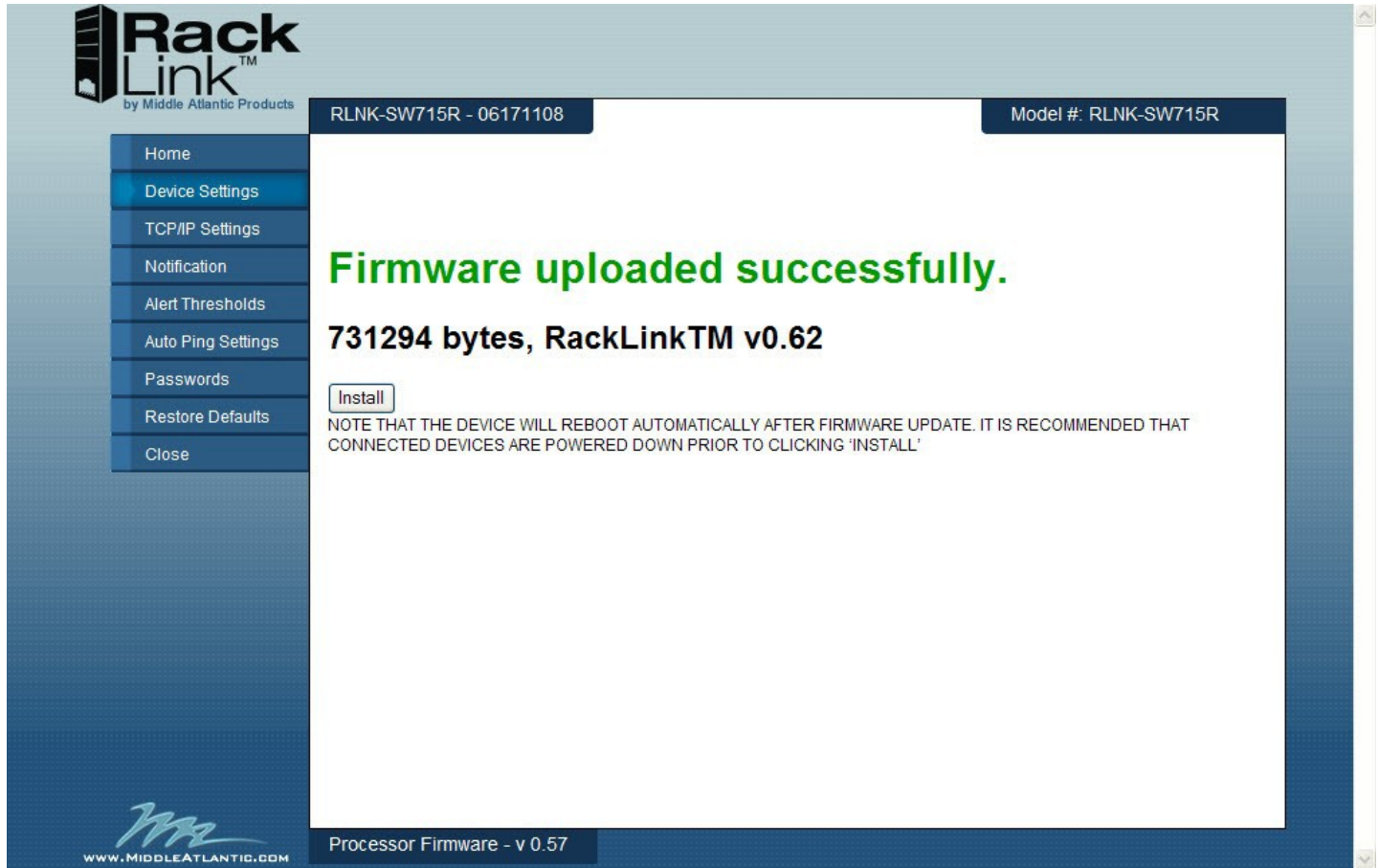

The screenshot shows the RackLink web interface. At the top left is the RackLink logo with the tagline "by Middle Atlantic Products". The top right displays the device ID "RLNK-SW715R - 06171108" and the model number "Model #: RLNK-SW715R". A left-hand navigation menu includes options: Home, Device Settings, TCP/IP Settings, Notification, Alert Thresholds, Auto Ping Settings, Passwords, Restore Defaults, and Close. The main content area features a large green heading "Firmware uploaded successfully." followed by "731294 bytes, RackLink™ v0.62". Below this is an "Install" button and a note: "NOTE THAT THE DEVICE WILL REBOOT AUTOMATICALLY AFTER FIRMWARE UPDATE. IT IS RECOMMENDED THAT CONNECTED DEVICES ARE POWERED DOWN PRIOR TO CLICKING 'INSTALL'". The bottom of the interface shows the "Processor Firmware - v 0.57" status and the website URL "WWW.MIDDLEATLANTIC.COM".

- Once the upload is completed, click **install** to complete the installation.
- You will see the following message until the device has fully completed the installation.

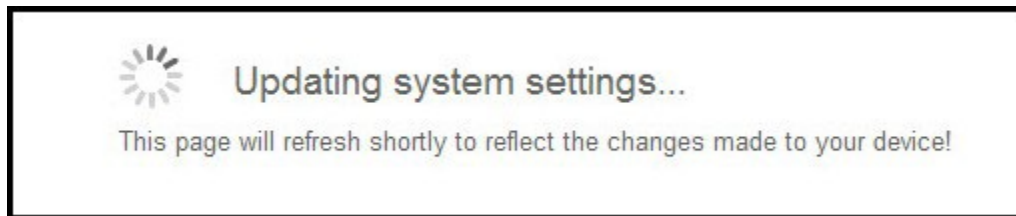

The message box contains a loading icon (a circle of dots) on the left. To its right, the text reads "Updating system settings..." in a bold font. Below this, in a smaller font, it says "This page will refresh shortly to reflect the changes made to your device!".

- Once the installation is complete, your device will reboot and you will be redirected to the My Device page.

MOBILE APPLICATION FUNCTIONALITY

There are two ways to discover your RackLink device. Using the Device Discovery software, or with the Device Discovery provided with the mobile application.

- For the mobile application to discover the RackLink device, the device and mobile phone must be on the same wireless network.
- This mobile application will allow the user to view the following current (live) readings:
 - Input Voltage (RMS)
 - Input Voltage (Peak)
 - Load Current (RMS)
 - Load Current (Peak)
 - Watts
 - Power Factor
 - Kilowatt Hours (Can be reset)
 - Thermal Load (BTU)
 - Temperature
- You can also control any controllable outlet(s) or dry contact(s) from your smart phone.
NOTE: You cannot perform any setup functions of your RackLink device from the mobile application.
- **DDNS Server Requirements (optional):** If you have an Internet line that has an address that remains the same (static), configure a port on your firewall to allow pass-through traffic to the RackLink device. Please see your router's instructions on opening ports. If you do not have a static IP address, you must first setup a method of the address change such as using a DDNS service. Once completed, follow those same instructions as if you had a static address and open a port on your router to allow traffic to pass-through.

SETTING IP ADDRESS WITH DIRECT CONNECTION TO A PC

This section details how to configure the IP settings of your RackLink device with a direct connection to a PC

The following items are required:

- RackLink Device.
- PC running Windows XP or greater. (Steps show in this section reflect Windows XP, these setup steps are similar on the other operating systems).
- Network Crossover Cable (Cat5e or better, not provided).
- Standard Network Cable (Cat5e or better, not provided).
- Pen and Paper.

SETTING UP THE PC

- 1) Disconnect the PC from any networks.
- 2) Click the **Start** button in the lower left corner of the screen. Then select **Control Panel**.

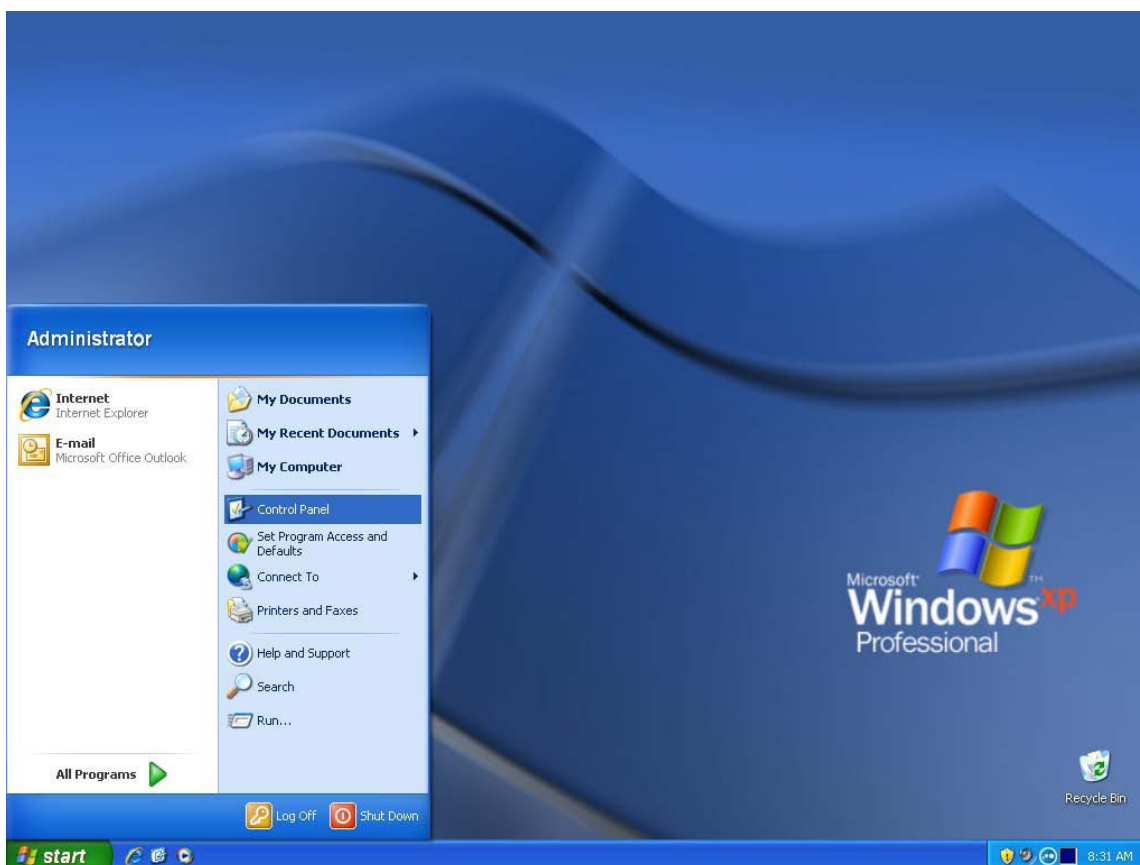

3) Once the Control Panel opens, double click **Network Connections**.

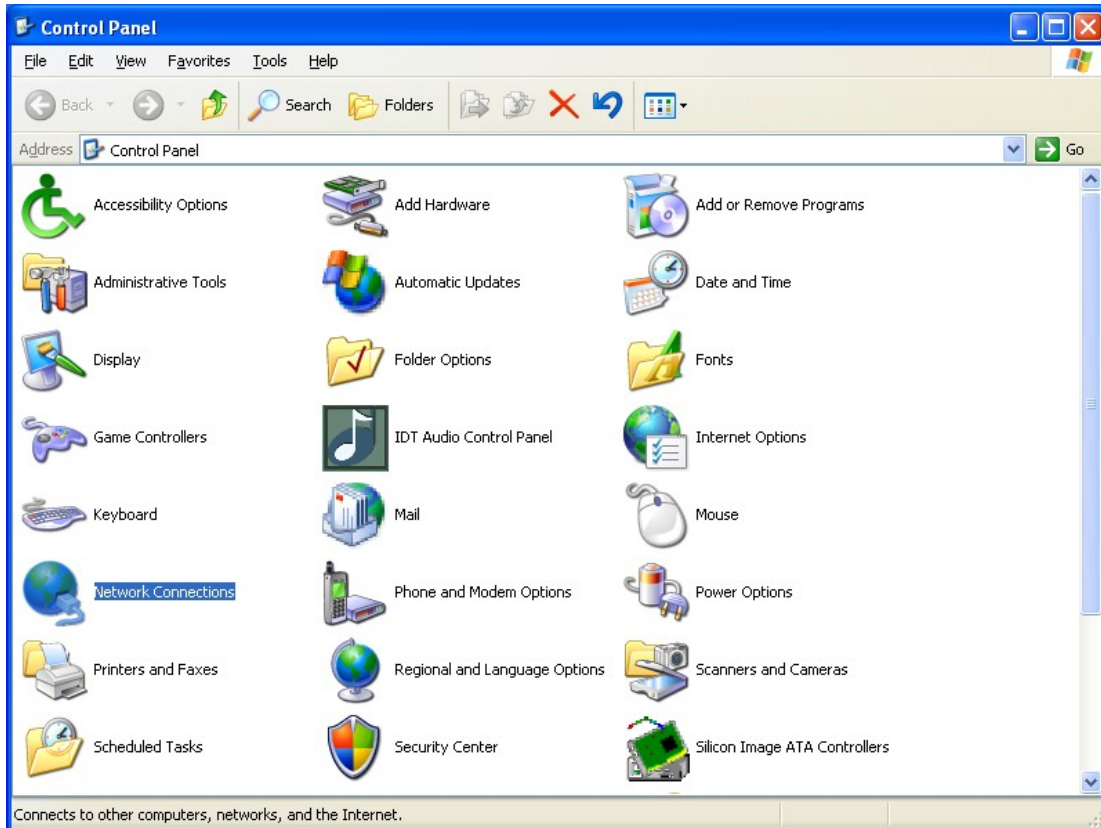

4) In the Network Connections window, locate the computer's **wired network** connection. It should be listed in the **LAN or High-Speed Internet** group and should have a name similar to Local Area Connection. **Right click** on the **connection** and then **left click** on **Properties**.

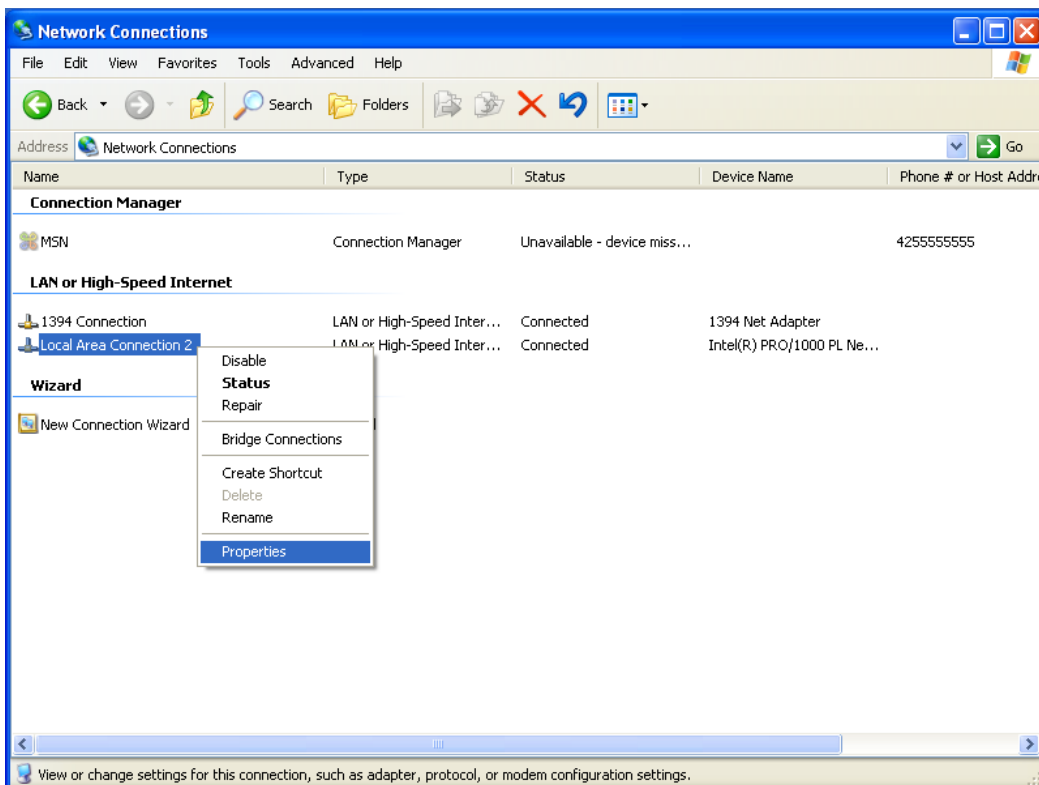

5) In the **Local Area Connection Properties** window, select **Internet Protocol (TCP/IP)** by clicking on it once. Click on the **Properties** button.

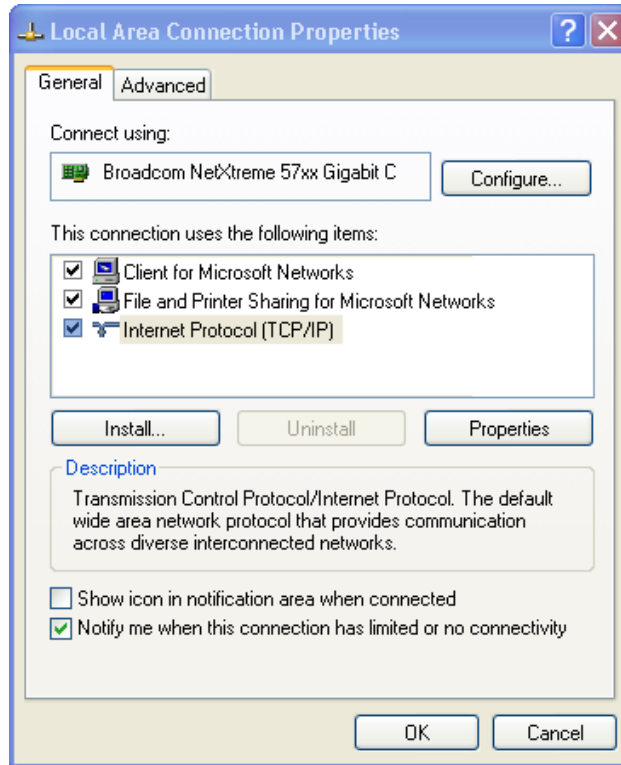

6) The Internet Protocol (TCP/IP) Properties window displays the computer's current settings and allows the settings to be changed. Write down the computer's current settings (these settings will be needed later to restore the computer to its original settings once RackLink has been set up).

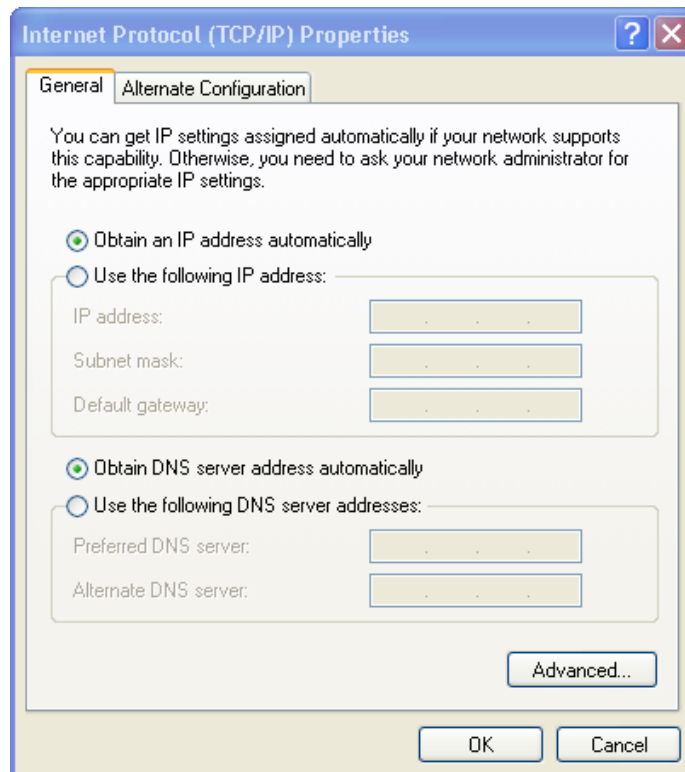

- 7) Select **Use the following IP address** and enter **192.168.1.100** in the **IP address** field. Enter **255.255.255.0** in the **Subnet mask** field. Leave the other fields blank. When the properties window looks like the following image, click **OK**.

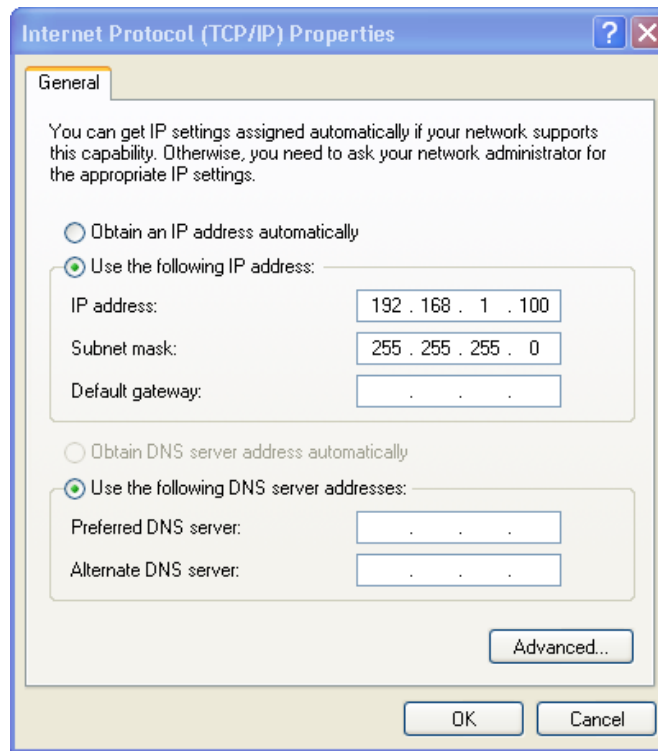

- 8) The PC setup is now complete. The PC may need rebooting for the new settings to take effect.

SETTING UP RACKLINK

- 1) Plug one end of the network crossover cable into the network jack on the rear of the RackLink unit and plug the other end into the PC's network jack.
- 2) Plug in the RackLink unit.
- 3) After a few seconds, the computer and the RackLink unit should establish a network connection. Open a **web browser** (Microsoft Internet Explorer 7 or higher is recommended) and navigate to **http://192.168.1.200**.
- 4) Login to the RackLink interface. The default **login** and **password** are **admin/admin**. The system forces you to change the default password for security purposes. For more information, see "User Interface Operation - Home Page" on page 19.
- 5) Navigate to the **Setup** menu and select **TCP/IP Settings**.
- 6) Change the network information to the desired settings and click **Apply**. After the settings have been changed, the RackLink unit will no longer be accessible from the connected PC.
- 7) Disconnect the network crossover cable connecting the RackLink unit and the computer.
- 8) Restore the PC to the original settings and put the RackLink device in its final location.

TROUBLESHOOTING

Question: What if I forget my password?

Answer: Press the Factory Reset button on the device. This defaults the permissions to admin/admin. For more information, see your specific model's feature set section at the end of this manual.

After resetting your device, the system forces you to change the default password for security purposes. For more information, see "User Interface Operation - Home Page" on page 19.

NOTE: If you have configured your RackLink to use TCP/IP, resetting the system restores it to using DHCP. For more information, see "Device Control" on page 17 and "TCP/IP Settings" on page 28.

Question: What could be wrong if I can't access the browser-based interface?

Answer: Check to see if you can access a standard web page, such as www.google.com. Verify that the Ethernet port's LEDs on the back of your RackLink device are solid yellow and blinking green. Review the procedures in "Device Control" on page 17.

Question: What if my RackLink device is inoperable after I perform a firmware upgrade?

Answer: Contact Middle Atlantic Products Technical Support at 1-800-266-7225.

Question: What if my RackLink device is not receiving power?

Answer: Ensure that the IEC connector on the line cord is fully inserted into the rear outlet and the line cord retention clip is securely fastened. Confirm that the circuit breaker is in the ON position. Plug another device into the exact same outlet your RackLink device was using and see if the other device functions.

RLNK-SW715R FEATURE SET



RLNK-SW715R FRONT VIEW

- 1) 2-Stage Surge Protection LEDs. Protected when lit.
- 2) Power Switch with Switch Guard.
- 3) System Alarm LED: The LED will illuminate when there is an alarm condition. The following conditions will cause an alarm condition. *Input Voltage Alert Threshold, Load Current Alert Threshold and Temperature Alert Threshold and a No Response to Auto Ping.*

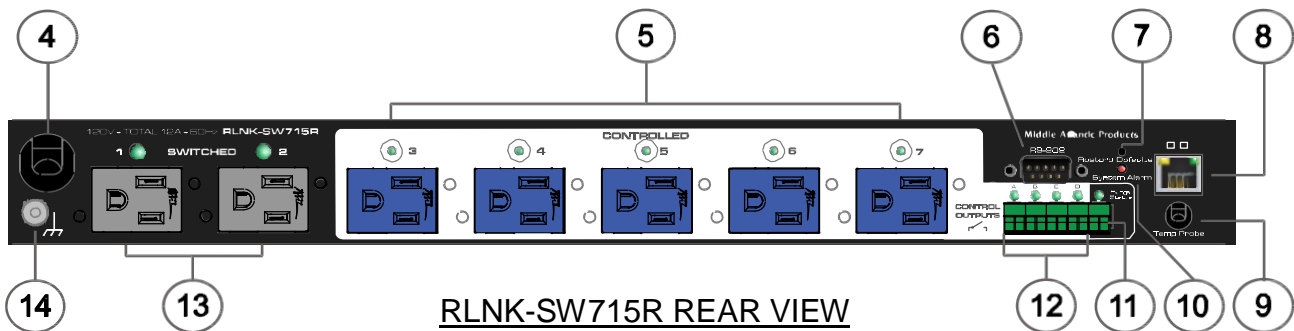

RLNK-SW715R REAR VIEW

- 4) Mains Power Cord: 120V nominal, 12A (total load, all outlets), 60Hz input.
- 5) Five Controlled Receptacles and Manual Push-Button Switches with Integrated On/Off LED: The LED will illuminate if the receptacle is energized.
- 6) RS-232, DB-9 Male Connector: Requires a female-to-female, null modem cable for communication with a control system.
- 7) Default Restoration Button: Resets to DHCP and to default passwords. For more information, see "Device Control" on page 17 and "User Interface Operation - Home Page" on page 19.
- 8) 10/100 Ethernet Port: Used to connect to a network, requires a Cat5e cable (or better, not provided).
- 9) Six Foot Temperature Probe: Mount at the highest available point in the enclosure.
- 10) System Alarm LED: The LED will illuminate when there is an alarm condition. *Input Voltage Alert Threshold, Load Current Alert Threshold and Temperature Alert Threshold and a No Response to Auto Ping.*
- 11) Surge Status Dry Contact Notification: When a surge occurs, the dry-contact will initiate a notification.
- 12) Four Dry Contact Controls: Can be opened or closed via the user interface.
- 13) Switched Receptacles: Controlled only by the main power switch.
- 14) Ground/Bond Stud.

RLNK-SW715R-NS FEATURE SET



RLNK-SW715R-NS FRONT VIEW

- 1) Power Switch with Switch Guard.
- 2) System Alarm LED: The LED will illuminate when there is an alarm condition. *Input Voltage Alert Threshold, Load Current Alert Threshold and Temperature Alert Threshold and a No Response to Auto Ping.*

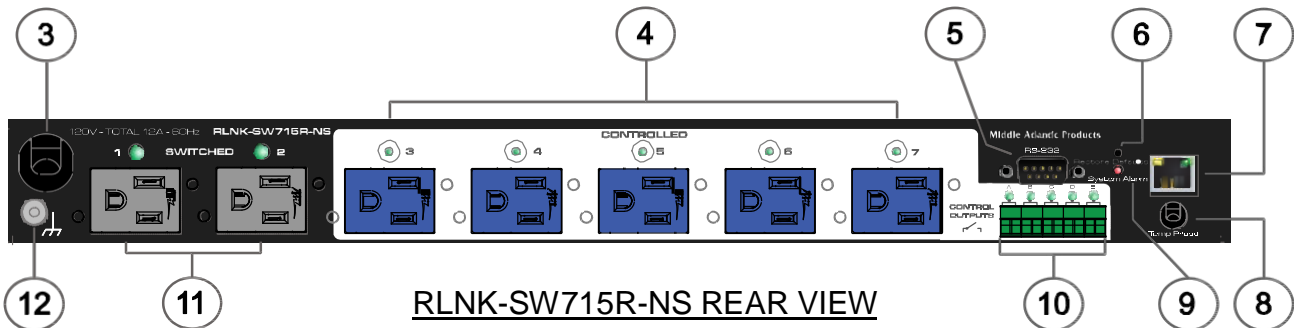

RLNK-SW715R-NS REAR VIEW

- 3) Mains Power Cord: 120V nominal, 12A (total load, all outlets), 60Hz input.
- 4) Five Controlled Receptacles and Manual Push-Button Switches with Integrated On/Off LED: The LED will illuminate if the receptacle is energized.
- 5) RS-232, DB-9 Male Connector: Requires a female-to-female, null modem cable for communication with a control system.
- 6) Default Restoration Button: Resets to DHCP and to default passwords. For more information, see "Device Control" on page 17 and "User Interface Operation - Home Page" on page 19.
- 7) 10/100 Ethernet Port: Used to connect to a network, requires a Cat5e cable (or better, not provided).
- 8) Six Foot Temperature Probe: Mount at the highest available point in the enclosure.
- 9) System Alarm LED: The LED will illuminate when there is an alarm condition. *Input Voltage Alert Threshold, Load Current Alert Threshold and Temperature Alert Threshold and a No Response to Auto Ping.*
- 10) Four Dry Contact Controls: Can be opened or closed via the user interface.
- 11) Switched Receptacles: Controlled only by the main power switch.
- 12) Ground/Bond Stud.

RLNK-SW620R FEATURE SET



- 1) 2-Stage Surge Protection LEDs. Protected when lit.
- 2) Power Switch with Switch Guard.
- 3) System Alarm LED: The LED will illuminate when there is an alarm condition. *Input Voltage Alert Threshold, Load Current Alert Threshold and Temperature Alert Threshold and a No Response to Auto Ping.*

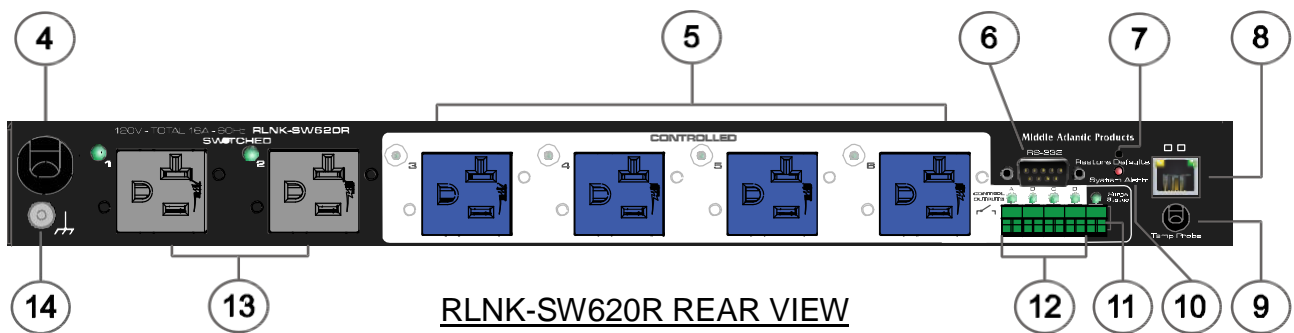

- 4) Mains Power Cord: 120V nominal, 16A (total load, all outlets), 60Hz input.
- 5) Four Controlled Receptacles and Manual Push-Button Switches with Integrated On/Off LED: The LED will illuminate if the receptacle is energized.
- 6) RS-232, DB-9 Male Connector: Requires a female-to-female, null modem cable for communication with a control system.
- 7) Default Restoration Button: Resets to DHCP and to default passwords. For more information, see "Device Control" on page 17 and "User Interface Operation - Home Page" on page 19.
- 8) 10/100 Ethernet Port: Used to connect to a network, requires a Cat5e cable (or better, not provided).
- 10) System Alarm LED: The LED will illuminate when there is an alarm condition. *Input Voltage Alert Threshold, Load Current Alert Threshold and Temperature Alert Threshold and a No Response to Auto Ping.*
- 11) Surge Status Dry Contact Notification: When a surge occurs, the dry-contact will initiate a notification.
- 12) Four Dry Contact Controls: Can be opened or closed via the user interface.
- 13) Switch Receptacles: Controlled only by the main power switch.
- 14) Ground/Bond Stud.

RLNK-SW620R-NS FEATURE SET



RLNK-SW620R-NS FRONT VIEW

- 1) Power Switch with Switch Guard.
- 2) System Alarm LED: The LED will illuminate when there is an alarm condition. *Input Voltage Alert Threshold, Load Current Alert Threshold and Temperature Alert Threshold and a No Response to Auto Ping.*

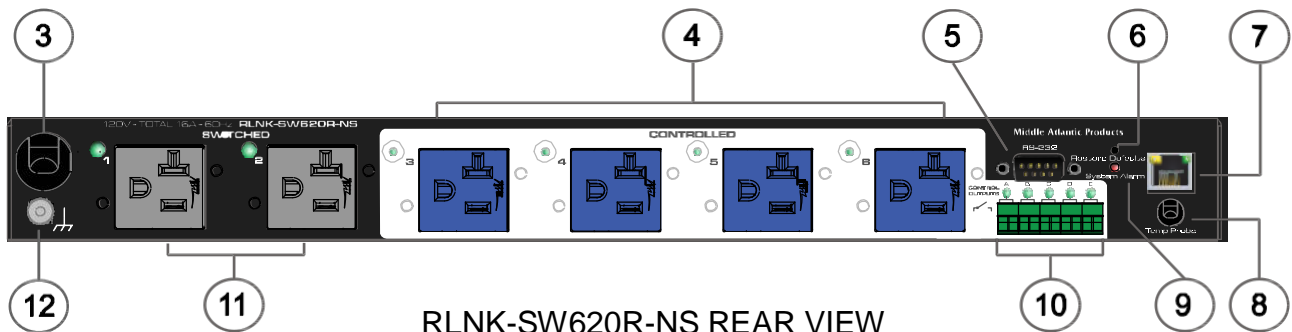

RLNK-SW620R-NS REAR VIEW

- 3) Mains Power Cord: 120V nominal, 16A (total load, all outlets), 60Hz input.
- 4) Four Controlled Receptacles and Manual On/Off Push-Button Switches with Integrated LED: The LED will illuminate if the receptacle is energized.
- 5) RS-232, DB-9 Male Connector: Requires a female-to-female, null modem cable for communication with a control system.
- 6) Default Restoration Button: Resets to DHCP and to default passwords. For more information, see "Device Control" on page 17 and "User Interface Operation - Home Page" on page 19.
- 7) 10/100 Ethernet Port: Used to connect to a network, requires a Cat5e cable (or better, not provided).
- 8) Six Foot Temperature Probe: Mount at the highest available point in the enclosure.
- 9) System Alarm LED: The LED will illuminate when there is an alarm condition. *Input Voltage Alert Threshold, Load Current Alert Threshold and Temperature Alert Threshold and a No Response to Auto Ping.*
- 10) Four Dry Contact Controls: Can be opened or closed via the user interface.
- 11) Switch Controlled Receptacles: Always on, controlled only by the main power switch.
- 12) Ground/Bond Stud.

RLNK-SW215-NS FEATURE SET

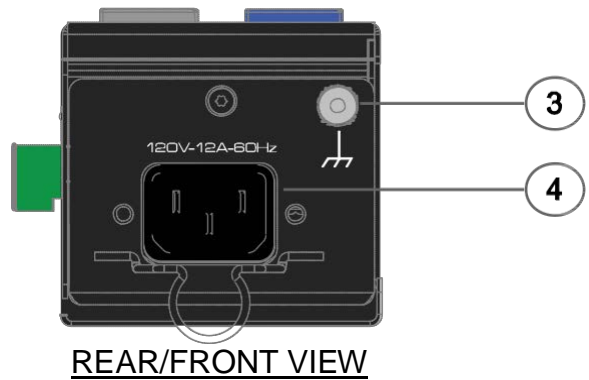
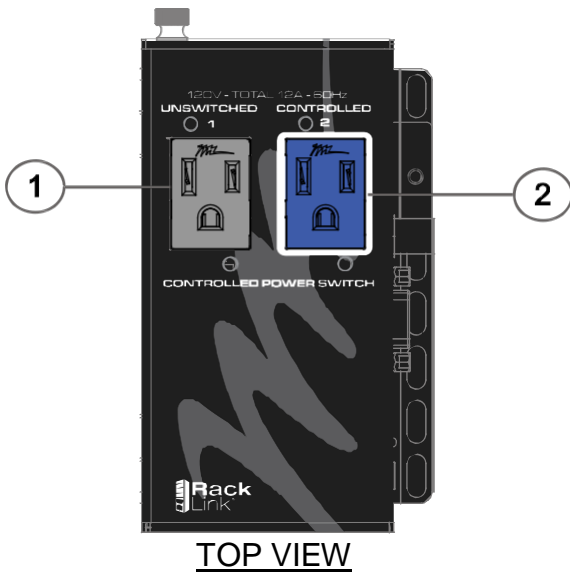

- 1) Unswitched Receptacle: 120V, 60Hz, 12A output (total load, all outlets).
- 2) Controlled Receptacle: 120V, 60Hz, 12A output (total load, all outlets).
- 3) Ground/Bond Stud.
- 4) Mains Power Inlet: 120V, 60Hz, 12A. IEC C13 inlet.

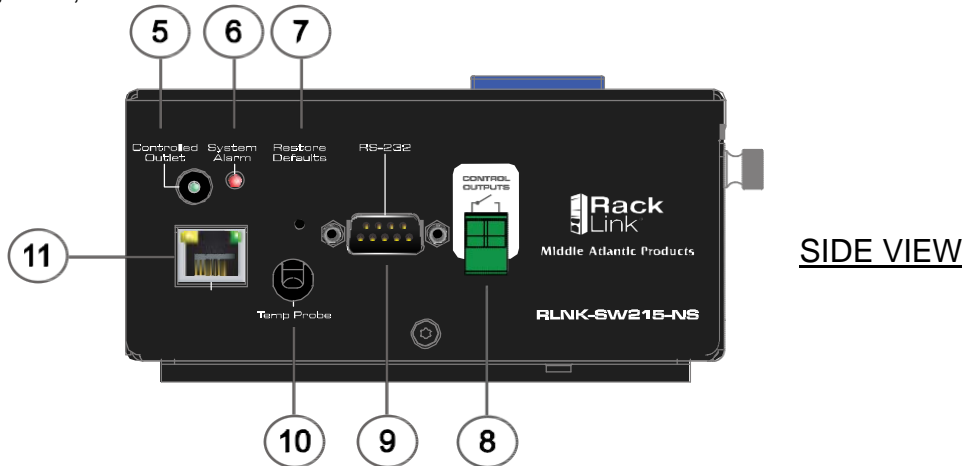

- 5) Controlled Receptacle Manual On/Off Push-Button with Integrated LED: The LED will illuminate if power if the receptacle is energized.
- 6) System Alarm LED: The LED will illuminate when there is an alarm condition. *Input Voltage Alert Threshold, Load Current Alert Threshold and Temperature Alert Threshold and a No Response to Auto Ping.*
- 7) Default Restoration Button: Resets to DHCP and to default passwords. For more information, see "Device Control" on page 17 and "User Interface Operation - Home Page" on page 19.
- 8) Dry Contact Control Output. Can be opened or closed via the user interface.
- 9) RS-232, DB-9 Male Connector: Requires a female-to-female, null modem cable for communication with a control system.
- 10) Six Foot Temperature Probe: Mount at the highest available point in the enclosure.
- 11) 10/100 Ethernet Port: Used to connect to a network, requires a Cat5e cable (or better, not provided).

RLNK-SW220-NS FEATURE SET

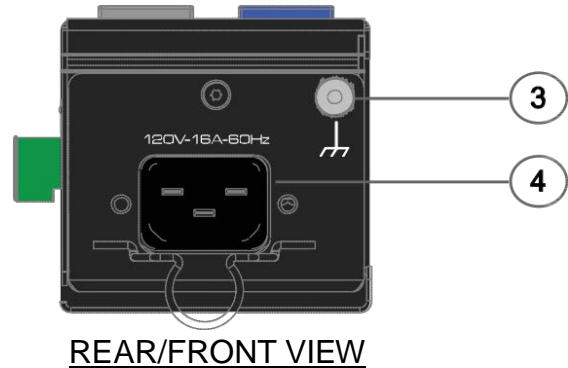
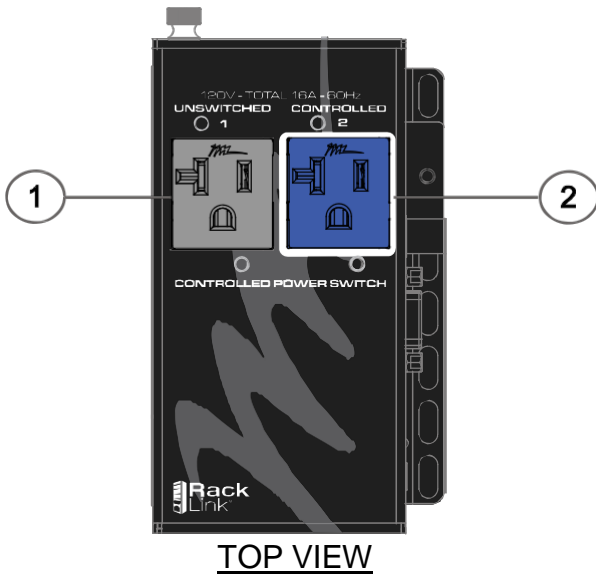

- 1) Unswitched Receptacle: 120V, 60Hz, 16A output (total load, all outlets).
- 2) Controlled Receptacle: 120V, 60Hz, 16A output (total load, all outlets).
- 3) Ground/Bond Stud.
- 4) Mains Power Inlet: 120V, 60Hz, 16A. IEC C13 inlet.

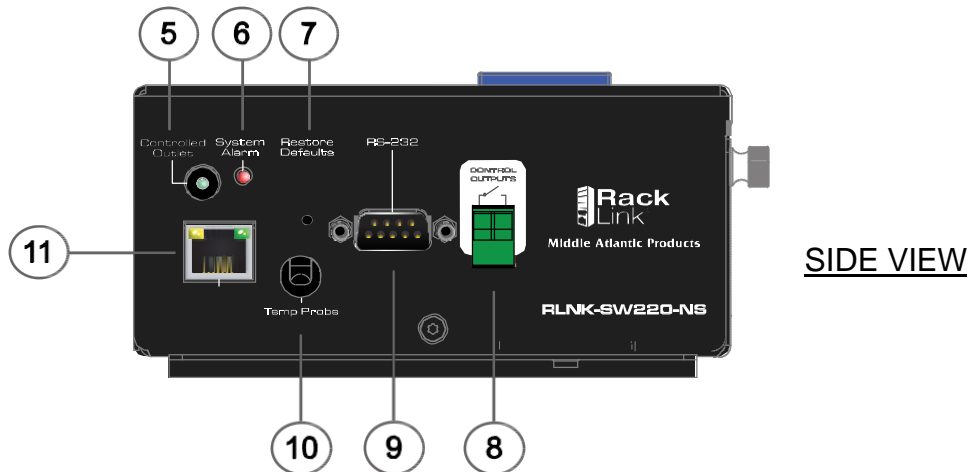

- 5) Controlled Receptacle Manual On/Off Push-Button with Integrated LED: The LED will illuminate if power if the receptacle is energized.
- 6) System Alarm LED: The LED will illuminate when there is an alarm condition. *Input Voltage Alert Threshold, Load Current Alert Threshold and Temperature Alert Threshold and a No Response to Auto Ping.*
- 7) Default Restoration Button: Resets to DHCP and to default passwords. For more information, see "Device Control" on page 17 and "User Interface Operation - Home Page" on page 19.
- 8) Dry Contact Control Output. Can be opened or closed via the user interface.
- 9) RS-232, DB-9 Male Connector: Requires a female-to-female, null modem cable for communication with a control system.
- 10) Six Foot Temperature Probe: Mount at the highest available point in the enclosure.
- 11) 10/100 Ethernet Port: Used to connect to a network, requires a Cat5e cable (or better, not provided).

RLNK-MON115-NS FEATURE SET

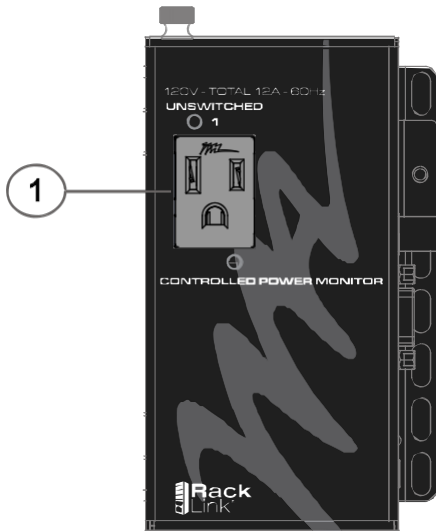

TOP VIEW

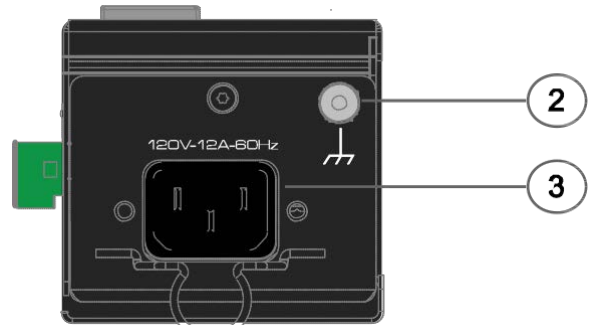

REAR/FRONT VIEW

- 1) Unswitched Receptacle: 120V, 60Hz, 12A.
- 2) Ground/Bond Stud.
- 3) Mains Power Inlet: 120V, 60Hz, 12A. IEC C13 inlet.

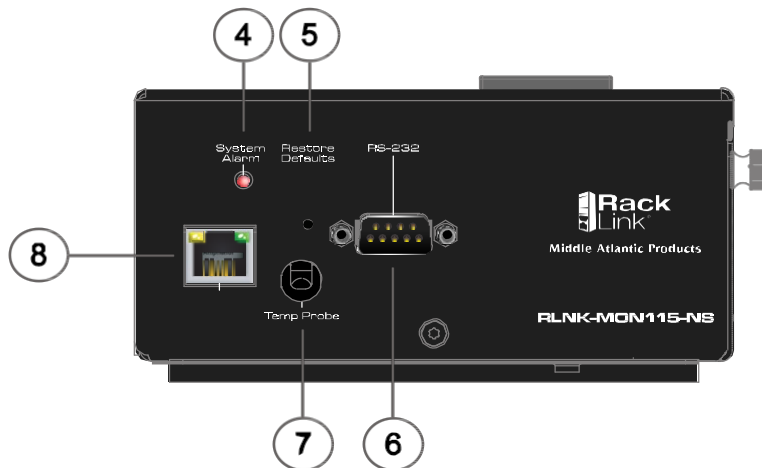

SIDE VIEW

- 4) System Alarm LED: The LED will illuminate when there is an alarm condition. *Input Voltage Alert Threshold, Load Current Alert Threshold and Temperature Alert Threshold and a No Response to Auto Ping.*
- 5) Default Restoration Button: Resets to DHCP and to default passwords. For more information, see "Device Control" on page 17 and "User Interface Operation - Home Page" on page 19.
- 6) RS-232, DB-9 Male Connector: Requires a female-to-female, null modem cable for communication with a control system.
- 7) Six Foot Temperature Probe: Mount at the highest available point in the enclosure.
- 9) 10/100 Ethernet Port: Used to connect to a network, requires a Cat5e cable (or better, not provided).

RLNK-MON120-NS FEATURE SET

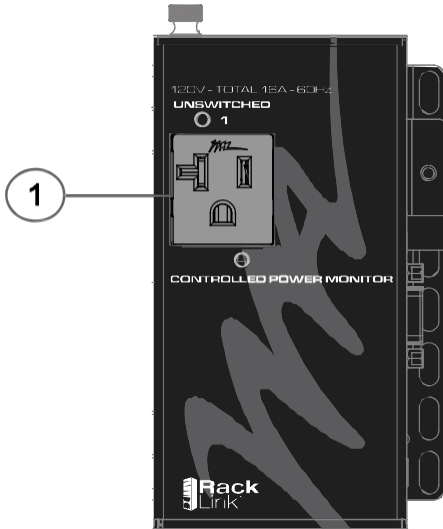

TOP VIEW

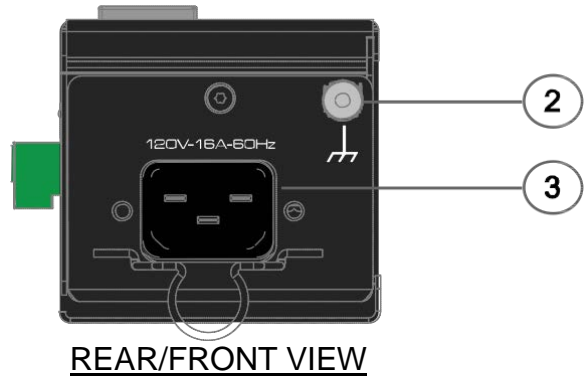

- 1) Unswitched receptacle: 120V, 60Hz, 16A.
- 2) Ground/Bond stud.
- 3) Mains Power Inlet: 120V, 60Hz, 16A. IEC C13 inlet.

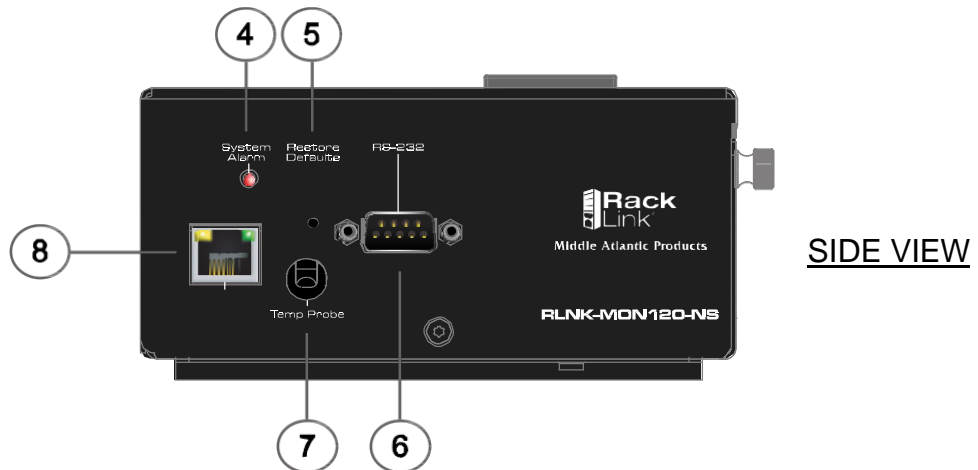

- 4) System Alarm LED: The LED will illuminate when there is an alarm condition. *Input Voltage Alert Threshold, Load Current Alert Threshold and Temperature Alert Threshold and a No Response to Auto Ping.*
- 5) Default Restoration Button: Resets to DHCP and to default passwords. For more information, see "Device Control" on page 17 and "User Interface Operation - Home Page" on page 19.
- 6) RS-232, DB-9 Male Connector: Requires a female-to-female, null modem cable for communication with a control system.
- 7) Six Foot Temperature Probe: Mount at the highest available point in the enclosure.
- 8) 10/100 Ethernet Port: Used to connect to a network, requires a Cat5e cable (or better, not provided).

RLNK-SW815R-SP FEATURE SET

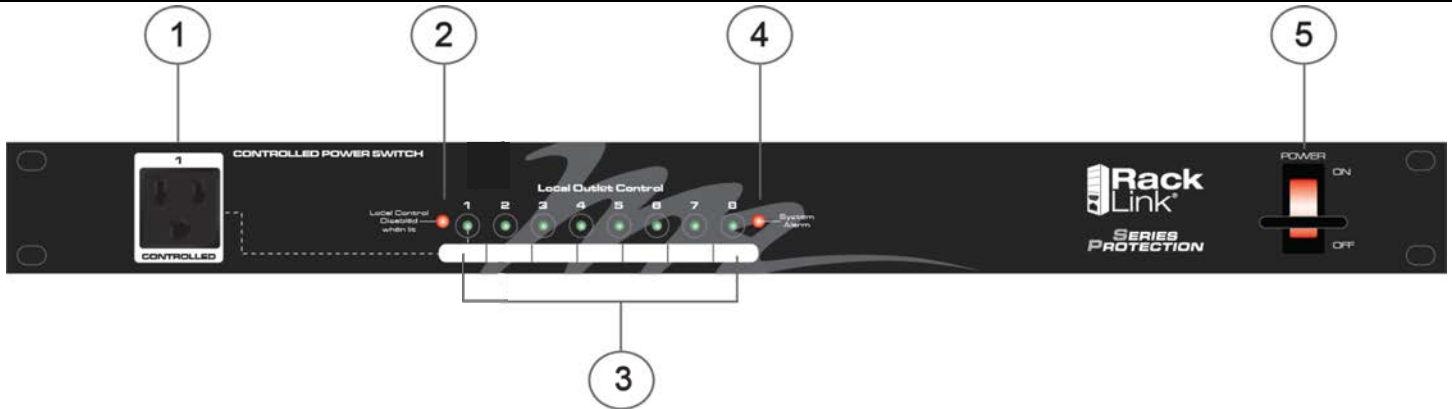

RLNK-SW815R-SP FRONT VIEW

- 1) Controlled Receptacle: Not included in sequence steps.
- 2) Local Control DISABLED When Lit: If local control is selected as disabled in the general settings section of the device settings page, this LED will illuminate.
- 3) Local Control On/Off Push-Button Switch with Integrated LED for Outlets 1 - 8: If local control is enabled, outlets 1 - 8 can be energized/denergized by pressing the button. When the outlet is energized the LED on the button will illuminate.
- 4) System Alarm LED: The LED will illuminate when there is an alarm condition. *Input Voltage Alert Threshold, Load Current Alert Threshold and Temperature Alert Threshold and a No Response to Auto Ping.*
- 5) Power Switch with Switch Guard.
- 6) Ground/Bond Stud.

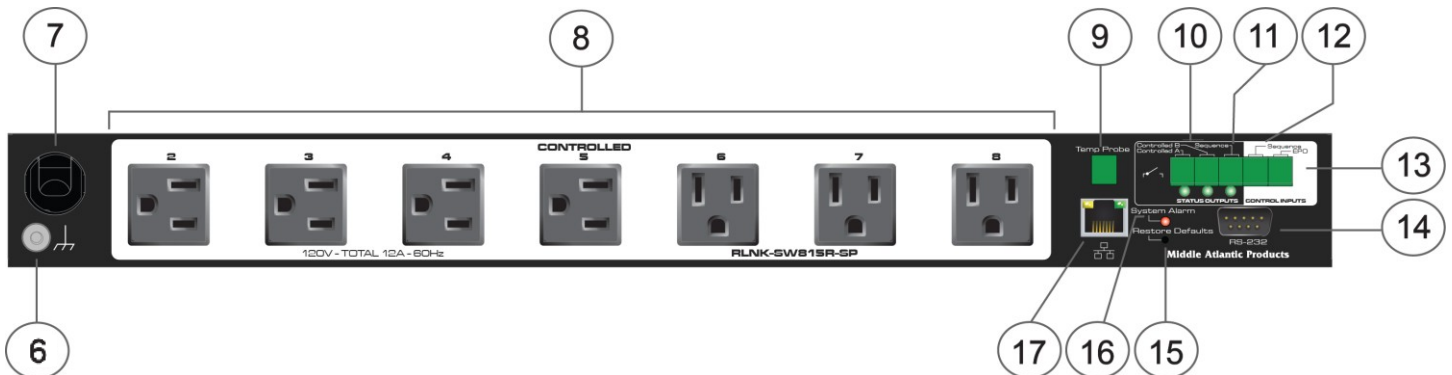

RLNK-SW815R-SP REAR VIEW

- 7) Mains Power Cord: 120V nominal, 12A (total load, all outlets), 60Hz input.
- 8) Controlled Outlets 2 – 8.
- 9) Six Foot Temperature Probe: Mount at the highest available point in the enclosure.
- 10) Two Dry Contact Output Controls (A and B): Can be opened or closed via the user interface. The LED will illuminate if the contact is closed.
- 11) Sequencing Status Output Dry Contact: When a sequence is initiated, this dry contact will close.
- 12) Sequence Dry Contact Control Input: Remote closure will cause the defined sequencing scheme to initiate.
- 13) EPO (Emergency Power Off) Dry Contact Control Input: Remote closure will cause all outlets to turn off at once.
- 14) RS-232, DB-9 Male Connector: Requires a female-to-female, null modem cable for communication with a control system.
- 15) Default Restoration Button: Resets unit to DHCP and to default passwords. For more information, see "Device Control" on page 17 and "User Interface Operation - Home Page" on page 19.
- 16) System Alarm LED: The LED will illuminate when there is an alarm condition. *Input Voltage Alert Threshold, Load Current Alert Threshold and Temperature Alert Threshold and a No Response to Auto Ping.*
- 17) 10/100 Ethernet Port: Used to connect to a network, requires a Cat5e cable (or better, not provided).

RLNK-SW820R-SP FEATURE SET

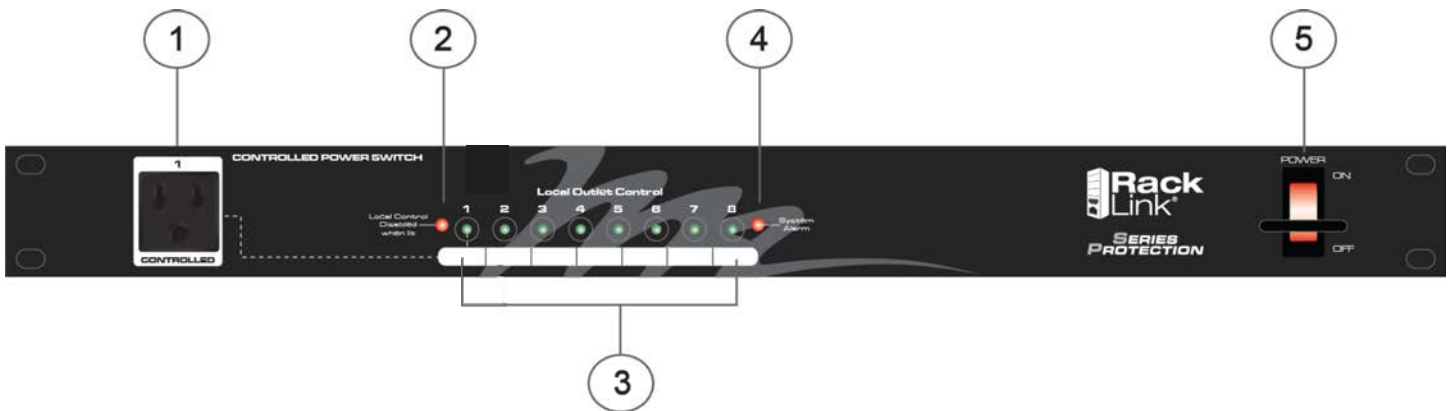

RLNK-SW820R-SP FRONT VIEW

- 1) Controlled Receptacle: Not included in sequence steps.
- 2) Local Control DISABLED When Lit: If local control is selected as disabled in the general settings section of the device settings page, this LED will illuminate.
- 3) Local Control On/Off Push-Button Switch with Integrated LED for Outlets 1 - 8: If local control is enabled, outlets 1 - 8 can be energized/denergized by pressing the button. When the outlet is energized the LED on the button will illuminate.
- 4) System Alarm LED: The LED will illuminate when there is an alarm condition. *Input Voltage Alert Threshold, Load Current Alert Threshold and Temperature Alert Threshold and a No Response to Auto Ping.*
- 5) Power Switch with Switch Guard.
- 6) Ground/Bond Stud.

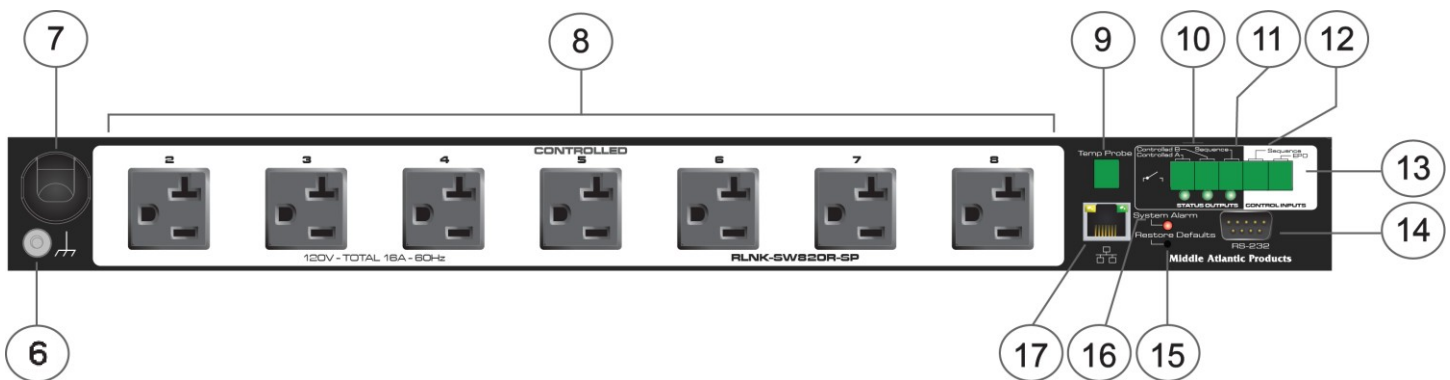

RLNK-SW820R-SP REAR VIEW

- 7) Mains Power Cord: 120V nominal, 16A (total load, all outlets), 60Hz input.
- 8) Controlled Outlets 2 – 8.
- 9) Six Foot Temperature Probe: Mount at the highest available point in the enclosure.
- 10) Two Dry Contact Output Controls (A and B): Can be opened or closed via the user interface. The LED will illuminate if the contact is closed.
- 11) Sequencing Status Output Dry Contact: When a sequence is initiated, this dry contact will close.
- 12) Sequence Dry Contact Control Input: Remote closure will cause the defined sequencing scheme to initiate.
- 13) EPO (Emergency Power Off) Dry Contact Control Input: Remote closure will cause all outlets to turn off at once.
- 14) RS-232, DB-9 Male Connector: Requires a female-to-female, null modem cable for communication with a control system.
- 15) Default Restoration Button: Resets unit to DHCP and to default passwords. For more information, see "Device Control" on page 17 and "User Interface Operation - Home Page" on page 19.
- 16) System Alarm LED: The LED will illuminate when there is an alarm condition. *Input Voltage Alert Threshold, Load Current Alert Threshold and Temperature Alert Threshold and a No Response to Auto Ping.*
- 17) 10/100 Ethernet Port: Used to connect to a network, requires a Cat5e cable (or better, not provided).

RLNK-SW415R-SP FEATURE SET

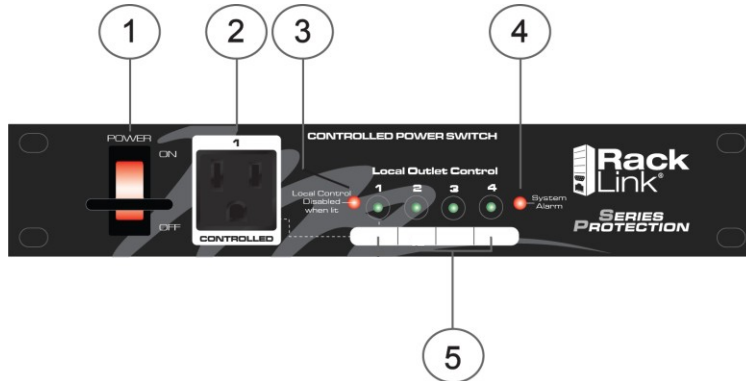

RLNK-SW415R-SP FRONT VIEW

- 1) Power Switch with Switch Guard
- 2) Controlled Receptacle: Not included in sequence step.
- 3) Local Control DISABLED When Lit: If local control is selected as disabled in the general settings section of the device settings page, this LED will illuminate.
- 4) System Alarm LED: The LED will illuminate when there is an alarm condition. *Input Voltage Alert Threshold, Load Current Alert Threshold and Temperature Alert Threshold and a No Response to Auto Ping.*
- 5) Local Control On/Off Push-Button Switch with Integrated LED for Outlets 1 - 4: If local control is enabled, outlets 1 – 4 can be energized/dennergized by pressing the button. When the outlet is energized the LED on the button will illuminate.
- 6) Ground/Bond Stud.

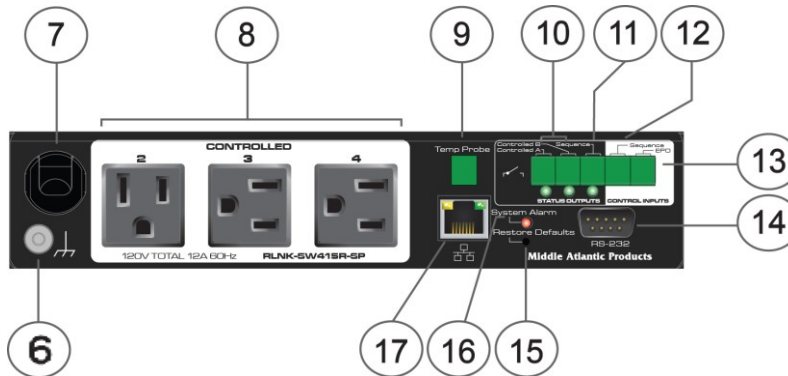

RLNK-SW415R-SP REAR VIEW

- 7) Mains Power Cord: 120V nominal, 12A (total load, all outlets), 60Hz input.
- 8) Controlled Outlets 2 – 4.
- 9) Six Foot Temperature Probe: Mount at the highest available point in the enclosure.
- 10) Two Dry Contact Output Controls (A and B): Can be opened or closed via the user interface. The LED will illuminate if the contact is closed.
- 11) Sequencing Status Output Dry Contact: When a sequence is initiated, this dry contact will close.
- 12) Sequence Dry Contact Control Input: Remote closure will cause the defined sequencing scheme to initiate.
- 13) EPO (Emergency Power Off) Dry Contact Control Input: Remote closure will cause all outlets to turn off at once.
- 14) RS-232, DB-9 Male Connector: Requires a female-to-female, null modem cable for communication with a control system.
- 15) Default Restoration Button: Resets unit to DHCP and to default passwords. For more information, see "Device Control" on page 17 and "User Interface Operation - Home Page" on page 19.
- 16) System Alarm LED: The LED will illuminate when there is an alarm condition. *Input Voltage Alert Threshold, Load Current Alert Threshold and Temperature Alert Threshold and a No Response to Auto Ping.*
- 17) 10/100 Ethernet Port: Used to connect to a network, requires a Cat5e cable (or better, not provided).

DIMENSIONS

IN-LINE MODELS

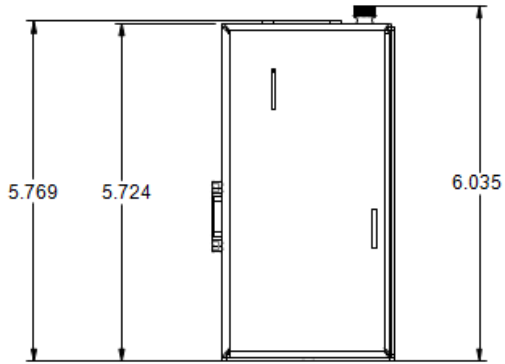

REAR VIEW

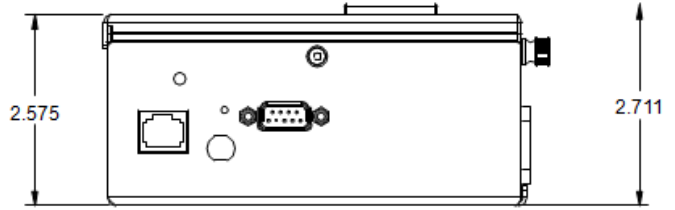

SIDE VIEW

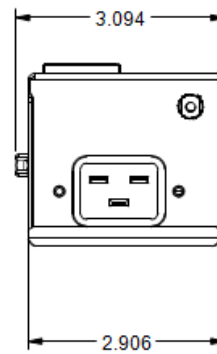

BACK/FRONT VIEW

RACKMOUNT MODELS

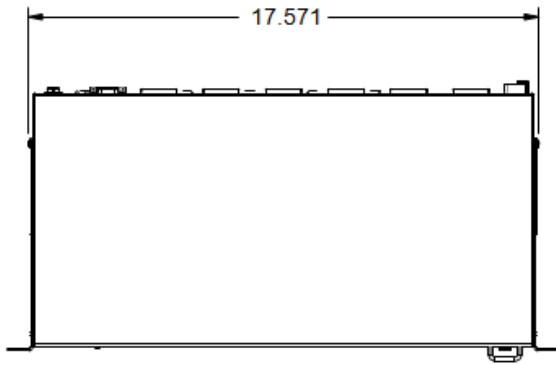

TOP VIEW

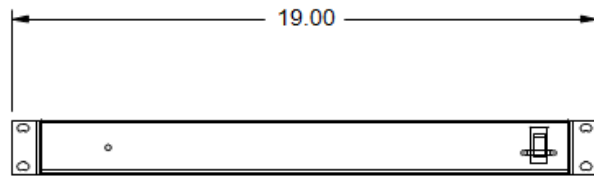

FRONT VIEW

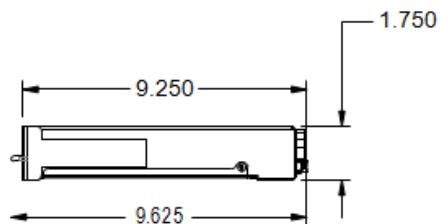

SIDE VIEW

HALF FRAME MODELS

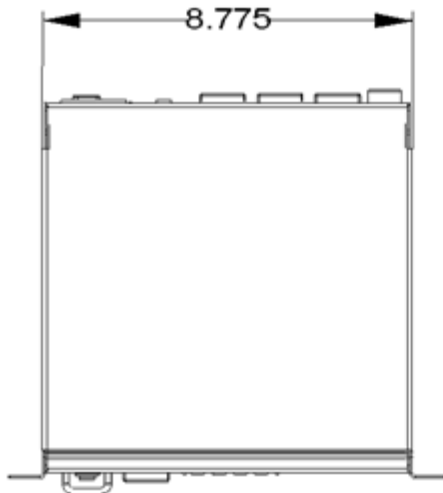

TOP VIEW

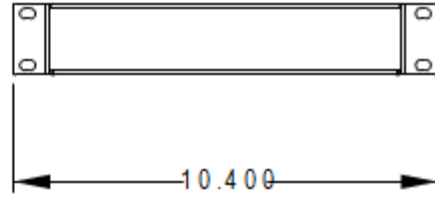

FRONT VIEW



SIDE VIEW

WARRANTY

For warranty information, refer to <http://www.middleatlantic.com/company/about-us.aspx#warranty>.

Corporate Headquarters

Voice: 973-839-1011 – Fax: 973-839-1976 – International Voice: +1 973-839-8821 –

Fax: +1 973-839-4982 – www.middleatlantic.com – info@middleatlantic.com

Middle Atlantic Canada

Voice: 613-836-2501 – Fax: 613-836-2690 – ca.middleatlantic.com – customerservicecanada@middleatlantic.ca

Middle Atlantic EMEA Technical Support

Voice: +31 (0) 495 726002 - av.emea.middleatlantic.support@legrand.com

Factory Distribution

United States: New Jersey, California, Illinois - Canada: Ontario - The Netherlands: Weert

At Middle Atlantic Products we are always listening. Your comments are welcome.

Middle Atlantic Products is an ISO 9001 and ISO 14001 Registered Company.