

Hi-5 Hand Unit

USER MANUAL

27th July 2021



Imprint

Copyright © 2021 Arnold & Richter Cine Technik GmbH & Co. Betriebs KG. All rights reserved. No parts of this document may be reproduced without prior written consent of Arnold & Richter Cine Technik GmbH & Co. Betriebs KG. Specifications are subject to change without notice. Errors, omissions, and modifications excepted.

ARRI, ALEXA, AMIRA, Master Grip, LDS and LENS DATA SYSTEM are trademarks or registered trademarks of Arnold & Richter Cine Technik GmbH & Co. Betriebs KG. All other brands or products are trademarks or registered trademarks of their respective holders and should be treated as such. Original version.

For Further Assistance

ARRI Cine + Video Geräte Gesellschaft m.b.H.

Pottendorferstraße 23-25/3/1

A-1120 Vienna Austria

E-mail: service@arri.com

Website: www.arri.com

Scope of this manual

This manual applies to the following product:

K2.0037280 Hi-5 Hand Unit

Revision History

Version	ID	Order #	Release	Date
01	10006313	K5.0039972	F07681	2021-07-27

1 Contents

1	Contents.....	4
2	How to Use this Manual.....	8
3	For Your Safety.....	10
4	Audience and Intended Use.....	12
5	Scope of Delivery and Warranty.....	13
6	Introduction to the Hi-5 Hand Unit.....	14
6.1	Hand Unit Layout.....	14
6.2	Control Elements.....	19
6.2.1	<i>Knob.....</i>	<i>19</i>
6.2.2	<i>Slider.....</i>	<i>19</i>
6.2.3	<i>Force-Pad.....</i>	<i>19</i>
6.3	Buttons.....	20
6.3.1	<i>Power Button.....</i>	<i>20</i>
6.3.2	<i>REC Button.....</i>	<i>20</i>
6.3.3	<i>PAGE Button.....</i>	<i>21</i>
6.3.4	<i>FUNC Button.....</i>	<i>21</i>
6.3.5	<i>Screen Buttons.....</i>	<i>21</i>
6.3.6	<i>User Buttons.....</i>	<i>22</i>
6.4	Touch Screen.....	22
6.5	Electrical Interfaces.....	23
6.5.1	<i>LBUS Interface.....</i>	<i>23</i>
6.5.2	<i>SERIAL Interface.....</i>	<i>23</i>
6.5.3	<i>USB-C Interface.....</i>	<i>23</i>
6.5.4	<i>USB-A Interface.....</i>	<i>23</i>
6.5.5	<i>Radio Module Interface.....</i>	<i>24</i>
6.5.6	<i>Smart Ring Interface.....</i>	<i>24</i>
6.6	Screen Pages.....	24
6.6.1	<i>Lens Data Display (LDD).....</i>	<i>24</i>
6.6.2	<i>Camera Screen.....</i>	<i>26</i>
6.6.3	<i>Menu Screen.....</i>	<i>27</i>
6.7	Radio Modules.....	27
6.8	Batteries.....	29

7	Preparations.....	31
	7.1 Inserting the Battery Pack.....	31
	7.2 Attaching a Smart Focus Ring.....	31
	7.3 Attaching a Radio Module.....	31
	7.4 Setting the language.....	32
	7.5 Setting Time and Date.....	32
8	Controlling Lens and Camera.....	33
	8.1 Connecting to Host Device.....	33
	8.2 Controlling Lens Motors.....	33
	8.3 Getting Lens Data on LDD.....	34
	8.4 Camera Control.....	36
	8.4.1 ARRI Camera Control.....	37
	8.4.2 RED Camera Control.....	37
	8.4.3 Sony Camera Control.....	38
9	Connecting to the ECS Sync App.....	39
10	Lens Programming.....	40
11	Lens File Management.....	41
12	Using Smart Focus Rings.....	43
13	Override Mode.....	44
14	Appendix.....	45
	14.1 Hi-5 Sets and Accessories.....	45
	14.2 Dimensions and Weight.....	48
	14.3 Electrical Data.....	51
	14.4 Environmental.....	52
	14.5 Service Mode.....	52
	14.6 Service Contacts.....	53
	14.7 Declarations of Conformity.....	56
	14.7.1 International declarations.....	56

Disclaimer

Before using the products described in this manual, be sure to read and understand all the respective instructions.

The ARRI Hi-5 Hand Unit is/are only available to commercial customers. By utilization, the customer agrees that the Hi-5 Hand Unit or other components of the system are deployed for commercial use only. Otherwise the customer must contact ARRI before utilization.

While ARRI endeavors to enhance the quality, reliability and safety of their products, customers agree and acknowledge that the possibility of defects thereof cannot be eliminated entirely. To minimize the risk of damage to property or injury (including death) to persons arising from defects in the products, customers must incorporate sufficient safety measures in their work with the system and heed the stated canonic use.

ARRI or its subsidiaries do not assume any responsibility for losses incurred due to improper handling or configuration of the Hi-5 Hand Unit or other system components.

ARRI assumes no responsibility for any errors that may appear in this document. The information is subject to change without notice.

For product specification changes after this manual was published, refer to the latest published ARRI data sheets or release notes, etc., for the most up-to-date specifications. Not all products and/or types are available in every country. Please check with an ARRI sales representative for availability and additional information.

Neither ARRI nor its subsidiaries assume any liability for infringement of patents, copyrights or other intellectual property rights of third parties by or arising from the use of ARRI products or any other liability arising from the use of such products. No license, express, implied or otherwise, is granted under any patents, copyrights or other intellectual property right of ARRI or others.

ARRI or its subsidiaries expressly exclude any liability, warranty, demand or other obligation for any claim, representation, cause, action, or whatsoever, express or implied, whether in contract or not, including negligence, or incorporated in terms and conditions, whether by statute, law or otherwise. In no event shall ARRI

or its subsidiaries be liable for or have a remedy for recovery of any special, direct, indirect, incidental, or consequential damages, including, but not limited to lost profits, lost savings, lost revenues or economic loss of any kind or for any claim by a third party, downtime, good-will, damage to or replacement of equipment or property, any cost or recovery of any material or goods associated with the assembly or use of our products, or any other damages or injury of the persons and so on or under any other legal theory.

In the event that one or all of the foregoing clauses are not allowed by applicable law, the fullest extent permissible clauses by applicable law are validated.

2 How to Use this Manual

This manual describes the necessary preparations to start using the product.

For further details, refer to the ARRI website at <http://arri.com/hi-5>:

For Tech Tips, please visit the ARRI Youtube Channel at <https://youtube.com/user/ar-richannel>:



All directions are given from a focus puller's point of view. For example, Hi-5 right side refers to the right side of the Hi-5 when holding it in two hands, with the focus knob on the right side and looking at the display.

Connectors are written in all capital letters, for example LBUS.

Menu paths and screens are written in italic typeface, with menu and LDD in capital letters, for example *MENU* > *Backlight* or *LDD* > *Lens*.

Buttons are written in italic typeface capital letters, for example *REC* button.

The appendix at the back of the manual contains useful reference material including Hi-5 technical data, connector pin-out diagrams and dimensional drawings.

Additional Information

For useful information in addition to this user manual please have a look at the [ARRI Learn & Help](#) section on the ARRI website.

Strengthen Your Knowledge and Get Trained

The ARRI Academy courses provide unrivalled insights into the full possibilities of working with ARRI camera systems, lenses, lights and accessories.

To learn more, please visit <http://arri.com/academy>.

3 For Your Safety

Before use, please ensure that all users read, understand and follow the instructions in this document fully. 使用前，请确保所有的用户都已经阅读、理解，并遵循本档内的操作说明。

Risk levels and alert symbols

Safety warnings, safety alert symbols, and signal words in these instructions indicate different risk levels:

DANGER

DANGER indicates an imminent hazardous situation which, if not avoided, **will result in** death or serious injury.

WARNING

WARNING indicates a potentially hazardous situation which, if not avoided, **may result in** death or serious injury.

CAUTION

CAUTION indicates a potentially hazardous situation which, if not avoided, **may result in** minor or moderate injury.

ADVICE

NOTICE explains practices not related to physical injury. No safety alert symbol appears with this signal word.

Note: Provides additional information to clarify or simplify a procedure.

Vital Precautions

WARNING

Risk of electric shock and fire!

Short-circuits may entail lethal damage!

Before use, read and follow all valid instructions.

Use solely and exclusively as described in the instructions.

Never open. Never insert objects.

For operation, always use a power source as indicated in the instructions.

Always unplug the cable by gripping the plug, not the cable.

Never try to repair. All repair work should be done by a qualified ARRI Service Center.

Never remove or deactivate any safety equipment (incl. warning stickers or paint marked screws).

Always protect from moisture, cold, heat, dirt, vibration, shock, or aggressive substances.

General precautions

Use only the tools, materials and procedures recommended in this document. Unplug all cables during transport.

ADVICE

Do not store the Hi-5 Hand Unit in places where it/they may be subject to temperature extremes, direct sunlight, high humidity, severe vibration, or strong magnetic fields.

4 Audience and Intended Use

The Hi-5 Hand Unit is solely and exclusively for use on professional camera setups.

ADVICE

The product is solely and exclusively available for commercial customers and shall be used by skilled personnel only. Every user should be trained according to ARRI guidelines.

Use the product only for the purpose described in this document. Always follow the valid instructions and system requirements for all equipment involved.

5 Scope of Delivery and Warranty

Delivery

A complete delivery of the KK.0039973 Hi-5 Hand Unit Body Kit includes:

- 1x Hi-5 Hand Unit Body (K2.0037280)
- 1x Bluetooth Dongle (K2.0039838)
- 1x Smart Focus Ring Blank (K2.0037463)
- 1x User manual
- 1x Original packaging

ADVICE

On delivery, please check if package and content are intact. Never accept a damaged/incomplete delivery.

ADVICE

Product and packaging contain recyclable materials. Always store, ship and dispose according to local regulations.

ARRI is not liable for consequences from inadequate storage, shipment or disposal.

ARRI offers an increasing variety of product bundles and additional accessories. For details, please consult our website or your local ARRI Service Partner.

Warranty

For scope of warranty, please ask your local ARRI Service Partner. ARRI is not liable for consequences from inadequate shipment, improper use or third-party products.

6 Introduction to the Hi-5 Hand Unit

The ARRI Hi-5 hand unit provides reliable wireless camera and multi-axis lens control in demanding situations on set. Robust and weatherproof, it features unique, swappable radio modules for different territories and shooting challenges, ensuring the best possible radio link range for every setup.

- Hi-performance: strong radio signal over long distances
- Hi-versatility: swappable radio modules for different locations
- Hi-speed: fast and efficient on-set ecosystem
- Hi-tech: future-proof hardware and software architecture
- Hi-reliability: robust, weatherproof, long battery life

6.1 Hand Unit Layout

Front Side

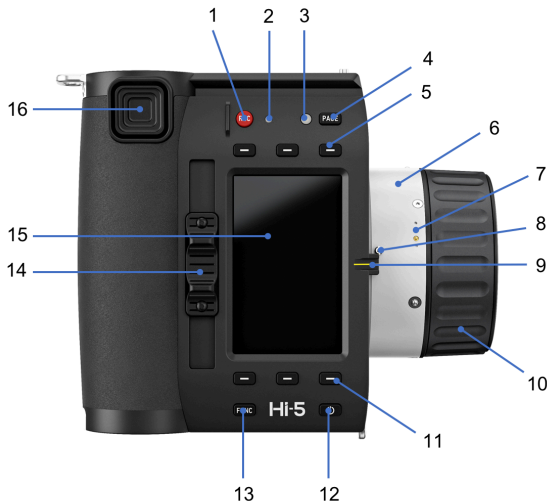

Right Side

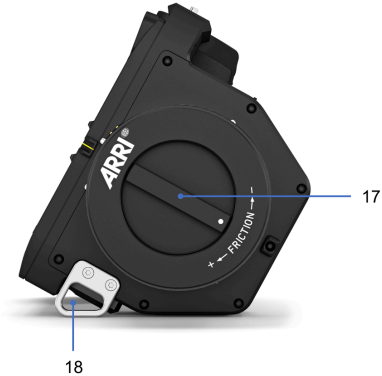

Left Side



Back Side

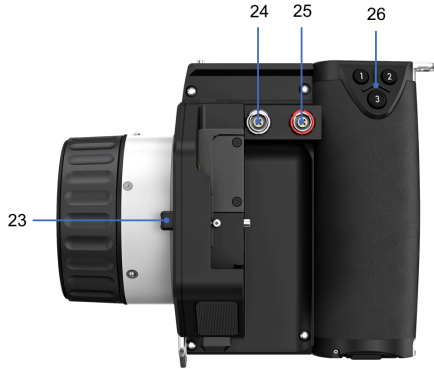

Top Side

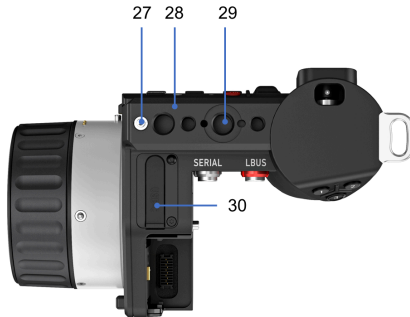

Bottom Side

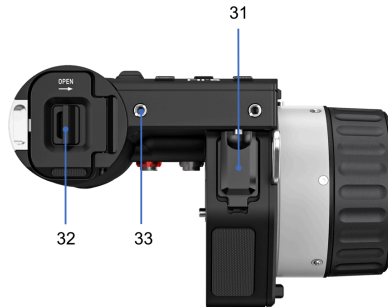

- 1 REC Button
- 2 REC Status LED
- 3 Ambient Light Sensor
- 4 PAGE Button
- 5 Upper Screen Buttons
- 6 Backlit Ring Area
- 7 Smart Ring Interface (Pogo Pins)
- 8 Registration Pin
- 9 Front Knob Index
- 10 Control Knob
- 11 Lower Screen Buttons
- 12 Power Button
- 13 FUNC Button

- 14 Slider
- 15 Touch Screen
- 16 Force-Pad
- 17 Friction Adjustment
- 18 Snaphook Eyelet
- 19 Snaphook/Hand Strap Eyelet
- 20 Radio Release Button
- 21 Radio Module Interface
- 22 Hand Strap Eyelet
- 23 Back Knob Index
- 24 SERIAL Connector
- 25 LBUS Connector
- 26 User Buttons
- 27 Nato-Rail Security Pin
- 28 Nato-Rail
- 29 3/8" -16 UNC and 1/4" - 20 UNC Mounting Interfaces
- 30 USB-C Interface
- 31 USB-A Interface
- 32 Battery Compartment
- 33 M4 Mounting Interfaces

6.2 Control Elements

6.2.1 Knob

The knob can control focus, iris and zoom motors and is set to control the focus motor by default. It features a friction adjustment mechanism and two Pogo pins to ARRI's Smart Focus Rings. The integrated backlight lets the focus ring glow in white, red, green, blue, yellow, magenta or cyan colors.

Turn the knob counterclockwise to focus towards infinity and turn it clockwise to focus towards close focus in the default setting. Press *PAGE* to enter the *MENU*, select *Control Setup > Knob* and tick the *Reverse* checkbox to change the direction.

6.2.2 Slider

The slider can control focus, iris and zoom motors and is set to control the iris motor by default.

Move the slider upwards to open the iris and move it clockwise to close the iris. Press *PAGE* to enter the *MENU*, select *Control Setup > Slider* and tick the *Reverse* checkbox to change the direction.

6.2.3 Force-Pad

The Force-Pad can control focus, iris and zoom motors and is set to control the zoom motor by default.

Push the Force-Pad upwards to zoom in and push it down to zoom out in the default setting. Press *PAGE* to enter the *MENU*, select *Control Setup > Force-Pad* and tick the *Reverse* checkbox to change the direction.

In menu mode, the Force-Pad can be used to navigate through the menu. It navigates in x- and y-directions, making it a good alternative to the touch screen. Also, use *User Button 3* to select a menu item and use *User Button 2* to go one level back.

6.3 Buttons

6.3.1 Power Button

Press the *Power* button momentarily to switch the hand unit on. Keep it pressed for two seconds to switch the hand unit off.

Pressing the *Power* button twice locks all control elements, buttons and the touch screen. Press the *Power* button twice again to unlock the hand unit.

6.3.2 REC Button

Press the *REC* button briefly to start recording. The REC Status LED will change to red color (with cameras supporting tally feedback).

Press the *REC* button again to stop recording.

Tail-Slate Mode

Hi-5 provides an tail-slate recording mode that prevents you from stopping recording before the tail-slate is taken.

Use the tail-slate mode as follows:

1. Press the *REC* button for 1 second start recording. A red end-slate icon will appear on the *Lens Data Display*, indicating that tail-slate mode is active.
2. Capture the tail-slate at the end of the shot.
3. Press the *REC* button again for 1 second to stop recording.



Pressing the REC button briefly during recording in tail-slate mode will not stop the recording, but generate a warning that tail-slate mode is active.

6.3.3 PAGE Button

Use the *PAGE* button to switch between screens. The default screen is the *Lens Data Display (LDD)*.

Pressing *PAGE* button once switches the display to the *Camera* screen (if Hi-5 is connected to a camera supporting this feature).

Pressing the *PAGE* button again switches to the *MENU* screen.

6.3.4 FUNC Button

Pressing the *FUNC* button shifts the screen button functionalities to additional levels. Additional function levels are indicated by tiny bars on the lower edge of the screen, above the lower center screen button.



FUNC level indicator

6.3.5 Screen Buttons

Six screen buttons are located above and below the display. They change their behavior depending on the screen content, indicating the function related to each button. Buttons without a label have no function on that screen.

6.3.6 User Buttons

The three user buttons on the back of the handgrip can be individually assigned. Use the *PAGE* button and go to *MENU > User Buttons* to assign a function for each user button.

In *Menu* and *Lens Programming* mode, use User Button 3 to select an item and use User Button 2 to go one level back.

6.4 Touch Screen

The touch screen supports tap, swipe, pinch and stretch gestures.

Gesture	How to do it
Tap	Tap the screen to perform an action.
Swipe	A movement of a fingertip across the screen in a vertical or horizontal direction.
Stretch	Pressing two fingers together on the screen, move them away from each other as if stretching them apart.
Pinch	Pressing two fingers apart on the screen, move them towards each other as if pinching them together.

On the *Lens Data Display*, swipe left to enter the *MENU* screen and swipe right to return.

Swipe right to enter the *Camera* screen (if available) and left to return.

Tap on a screen button label to enter.

Pinch and stretch in vertical direction to compress or expand the on-screen focus scale.

In the *Menu*, swipe up or down to scroll. Tap on a menu item to enter or select.

6.5 Electrical Interfaces

6.5.1 LBUS Interface

The LBUS interface at the back of the hand unit communicates LBUS and LCS protocols. It can be used to hardwire the Hi-5 to ARRI camera hosts, to control panels of ARRI's Camera Stabilizing Systems and to other LBUS devices.

6.5.2 SERIAL Interface

The SERIAL connector is for future use.

6.5.3 USB-C Interface

The USB-C interface is placed under a rubber lid on the Hi-5 top side. It can be used for the following:

- Software updates via flash drive (supports USB-C card readers as well)
- Exchange of lens files and user setup files via flash drive (supports USB-C card readers as well)
- External power supply
- IP connection to a laptop for entering the service mode through a web browser

6.5.4 USB-A Interface

The USB-A interface is placed under a plastic cover on the bottom side of the Hi-5 hand unit. It contains a Bluetooth stick for connecting to the ECS Sync app.

Besides establishing a connection to the ECS Sync app via Bluetooth stick, the USB-A interface can be used for the following:

- Software updates via flash drive (supports USB-A card readers as well)
- Exchange of lens files and user setup files via flash drive (supports USB-A card readers as well)

6.5.5 Radio Module Interface

The RIA-1 contains a radio module interface for ARRI's exchangeable radio modules (RF-EMIP Radio Module 2400 MHz DSSS, RF-2400 Radio Module 2400 MHz FHSS and RF-900 Radio Module 900 MHz FHHSS).

ATTENTION

Always keep the Radio Interface clean and dry!

Do not leave the Radio interface open during transportation and storage. Attach the RF Cover or a radio module instead

6.5.6 Smart Ring Interface

The Hi-5 knob contains two spring-loaded pins as an interface for ARRI's Smart Focus Rings. They establish an electrical connection between the chip on a Smart Focus Ring and the Hi-5 hand unit.

6.6 Screen Pages

6.6.1 Lens Data Display (LDD)

The *Lens Data Display (LDD)* is the default screen. It displays the most important parameters of the hand unit and the host of the camera side, and shows the current position of the motors attached to the focus, iris and zoom lens rings.

The distance readout of compatible measuring devices such as the Ultrasonic Distance Measure UDM-1, Cine RT, Cine Tape, Ward Sniper or cfinder III will automatically appear on the *LDD* screen if connected to the respective camera host. The distance readout is displayed as a number above the focus value in the center of the *LDD* screen and as an arrow on the *LDD* focus scale.

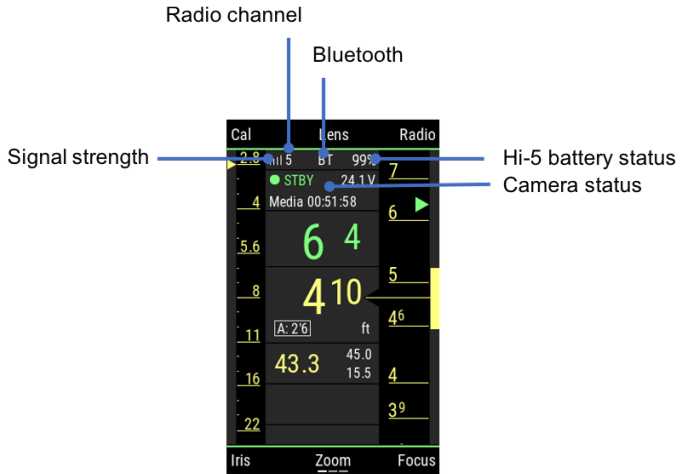

Motor Trails

The scales on the Hi-5 *Lens Data Display* represent the current position of the knob and slider controls. Fast focus and iris racks can result in an offset between those target values and the actual position of the lens rings, as the lens motor can take more time to travel to the desired position than the focus knob and iris slider do. Such an offset is indicated by the focus and iris trails that are represented as a white line next to the focus and iris scales.

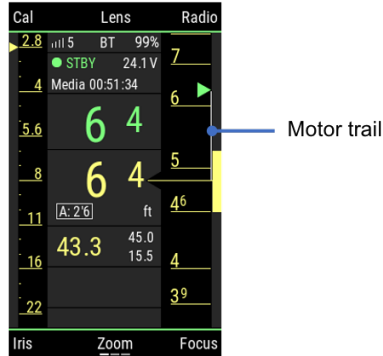

Depth-of-Field Bar

The yellow depth-of-field bar right to the focus scale indicates the distance range between the nearest and the farthest objects that are in acceptably sharp focus.

It is calculated based on focal length (zoom setting), focus distance (focus setting), aperture (iris setting), and the circle of confusion size.

While focal length, focus distance and aperture depend on the physical settings of the lens, the circle of confusion can be set as a numerical value in the hand unit.

6.6.2 Camera Screen

The *Camera* screen shows the camera status and the name of the active lens file. It also allows changing basic camera parameters.

The *Camera* screen will display whenever a digital ARRI camera is connected. For RED and Sony cameras, an additional license is required.

Cam Setup		SDI
CAMERA A		STBY ●
CODEC	ProRes 4444	
REC TIME	00:00:51:34	
BAT	24.1 V	
LENS	Fujinon Alura	
FPS	SHUTTER	
25.000	180.0°	
Exp. Index	ND	
500	0.6	
WB		
5600 0.0 CC		
Cam User		Play

6.6.3 Menu Screen

The *MENU* contains all parameters for setting up the Hi-5 hand unit as well as connected accessories such as motors and distance measurers.

Use the *PAGE* button and go to *MENU > System* to perform software updates, manage licenses and download log files.

Menu	
Premarked Ring	A: 2'6
Control Setup	>
Motor Setup	>
User Setups	>
Backlight	>
Vibration	>

6.7 Radio Modules

ARRI offers three different exchangeable radio modules for various shooting conditions and regions.

⚠ WARNING

For further information, please refer to the manual of the respective products.

RF-EMIP Radio Module

The RF-EMIP radio module is backwards-compatible to devices including the ARRI's white-coded radio (EMIP) modules (e.g. ALEXA Mini, cforce mini RF). It can establish a point-to-multipoint communication for connecting up to three hand units with one camera device.

Frequency:	2400 MHz
Modulation:	Direct-sequence spread spectrum (DSSS)
Number of channels:	14

RF-2400 Radio Module

The RF-2400 can establish a point-to-point communication for connecting one Hi-5 hand unit with one Radio Interface Adapter RIA-1 with the corresponding RF-2400 radio module.

Its frequency hopping transmission method ensures a strong radio link with exceptionally good interference immunity.

Frequency:	2400 MHz
Modulation:	Frequency-hopping spread spectrum (FHSS)
Number of channels:	100

RF-900 Radio Module

The RF-900 radio module can establish a point-to-multipoint communication for connecting up to three hand units with one camera device.

Its frequency hopping transmission method ensures a strong radio link with exceptionally good interference immunity.

Frequency:	900 MHz
Modulation:	Frequency-hopping spread spectrum (FHSS)
Number of channels:	100

⚠ WARNING

The RF-900 radio module is for usage in USA and Canada only!

ADVICE

When removing the radio modules from the hosting units (Hi-5 Hand Unit, Radio Interface Adapter RIA-1), please check the temperature of the radio modules first. If they are hot, please wait until they have cooled down.

ADVICE

The RF-2400 and RF-900 radio modules need to be attached to the Radio Interface Adatppter RIA-1 on the camera side.

6.8 Batteries

We recommend using ARRI's LBP-3500 Li-Ion batteries for the Hi-5 hand unit.

The LBP-3500 batteries have a capacity of 3,500 mAh. They include a chip that communicates the capacity of the battery to the hand unit in real-time. The hand unit accurately displays the remaining capacity in %.

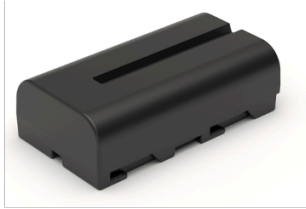

Battery status

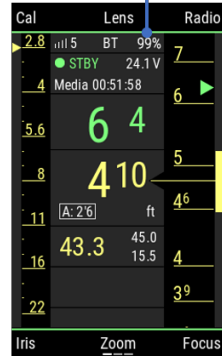

The Hi-5 hand unit is compatible to the L-Series battery interface and works with respective 3rd-party batteries such as NP-F550 type batteries. However, there is no accurate capacity display with these batteries and the hand unit can shut off abruptly without warning.

7 Preparations

7.1 Inserting the Battery Pack

1. Open the battery compartment.
2. Insert the ARRI LBP-3500 battery pack.
3. Close the battery compartment.

ADVICE

Use the LBP Battery Charger to charge the battery before use.

7.2 Attaching a Smart Focus Ring

1. Go to *MENU > Premarked Ring* and select *Auto*.
2. Slide the ring onto the knob so that the notch on the ring meets the registration pin on the knob.
3. The ring will be automatically detected by the Hi-5 hand unit.

7.3 Attaching a Radio Module

1. Press the Radio Release Button and remove the RF Cover by sliding it upwards.
2. Insert the radio module by fitting it into the radio module slot and sliding it downwards until the Radio Release Button pops back out.

ADVICE

You always need the same type of radio module on the camera side!

If you use an RF-2400 or RF-900 radio module with Hi-5, you need the same on the camera side, attached to the Radio Interface Adapter RIA-1.

If you use the RF-EMIP module, you are compatible with the white-coded radio module built in ARRI cameras and motor controllers.

7.4 Setting the language

The graphical user interface of the Hi-5 is available in English, Chinese, Spanish and German language.

1. Go to *MENU* > *System* > *Language*.
2. Select your desired language.

7.5 Setting Time and Date

The Hi-5 provides log file generation for service purposes. Time and date are essential information for those log files. It is therefore recommended to set time and date before use.

1. Go to *MENU* > *System* > *Timezone*.
2. Select the timezone you are in.
3. Go to the menu item displaying *Date/Time* and set the current date and time.

8 Controlling Lens and Camera

8.1 Connecting to Host Device

1. Press the *Radio* button on the *LDD* screen.
2. Select the same radio channel as set on the corresponding camera host.
3. Switch the radio transmission on by ticking the *Power* checkbox.
4. Return to the *LDD* screen by pressing the *back* or *PAGE* button.

The selected radio channel will be indicated in the top center area of the *LDD* screen. A signal strength indicator will be displayed as soon as a connection between Hi-5 and camera host is established.

ATTENTION

Any region setting set in the Hi-5 Radio Menu prior to connecting to a host device will be overruled by the region setting of the host device.

Make sure that the selected region setting fits your location. It may not be legal to operate the Hi-5 hand unit with the attached radio module in a country/region other than the country/region set in the Hi-5 radio system. Switch the radio off and use the device in hardwired mode if you are unsure of the correct region setting.

8.2 Controlling Lens Motors

1. Connect the lens motors to the camera host device and power up. In case you use cforce motors, assign each motor to the respective lens axis (see cforce motor user manual for details).
2. Power up the hand unit by pressing the *POWER* button.

3. Connect to the host device. A calibration request will appear on the LDD screen.
4. Calibrate all lens motors by pressing the *Cal* screen button twice.

You can now use knob, slider and Force-Pad to control the motors they are assigned to. You can change the control for a lens motor at *MENU > Control Setup*.

8.3 Getting Lens Data on LDD

The *Lens Data Display (LDD)* shows the current settings of the lens. It provides numerical values for the focus and zoom settings, as well as iris and focus scales. The yellow depth-of-field bar right to the focus scale indicates the distance range between the nearest and the farthest objects that are in acceptably sharp focus.

Lens data is generated with encoder values representing the physical settings of the lens rings and a lens file translating those values into human-readable numbers. In case you use an LDS lens on an ARRI camera, you will get lens data instantly. In case you use a non-LDS lens, the encoder values are generated by the lens motors and you have to manually load the corresponding lens file.

Wireless Lens File Transfer

The Hi-5 hand unit can transfer lens files wirelessly to the following devices:

- ALEXA Mini camera
- ALEXA Mini LF camera
- Universal Motor Controller UMC-4
- cforce mini RF lens motor

To transfer a lens file wirelessly from Hi-5, do as follows:

1. Go to *LDD > Lens > Lens Files*.
2. Select the lens file.
3. Press *use* to send the lens file to the camera device and activate it there.

Lens File Transfer with External Flash Drive

Lens file transfer with an external flash drive is required for the following devices:

- All ALEXA Classic cameras including the Plus Module (ALEXA Plus, ALEXA SXT, ALEXA LF, ALEXA 65)

To transfer a lens file with an external flash drive from Hi-5, do as follows:

1. Prepare an SD card with the following folder structure: ARRI/ALEXA/LDA .
2. Attach a card reader with the SD card in it to the USB-C port of the Hi-5.
3. Go to *LDD > Lens > Lens Files*.
4. Press *FUNC* to enter *FUNC Level 2*.
5. Select *Internal Lens File* and select the lens file you want to transfer to the camera.
6. Press the *FUNC* button to select whether to *copy* or *move* the lens files to the SD card.
7. Navigate to the folder ARRI/ALEXA/LDA .
8. Press *export* to transfer the lens files to the folder on the SD card.
9. Remove the SD card from Hi-5 and insert it to the camera.
10. Load the lens files into the camera.

Setting the Circle of Confusion

The yellow depth-of-field bar right to the focus scale indicates the distance range between the nearest and the farthest objects that are in acceptably sharp focus.

It is calculated based on focal length (zoom setting), focus distance (focus setting), aperture (iris setting), and the circle of confusion size.

While focal length, focus distance and aperture depend on the physical settings of the lens, the circle of confusion can be set as a numerical value in the hand unit.

To set the circle of confusion, do as follows:

1. Go to *LDD > Lens > Circle of Confusion*.
2. Select a circle of confusion diameter.

ADVICE

The perceived sharpness of an image depends on the lens characteristics, the camera sensor and image processing, the scene content, the setting of the lens and eventually the display the image is viewed on.

The depth-of-field bar on a hand unit is just an indication for the distance range in which objects appear in acceptably sharp focus.

Always test the actual depth-of-field of your setup before shooting and adjust the circle of confusion if needed.

As a guideline, we recommend the following circle of confusion settings:

- | | |
|---------|--|
| 0.013mm | For maximum detail contrast on Super 35 cameras. |
| 0.025mm | Standard setting for Super 35 cameras. |
| 0.035mm | Standard setting for Large Format cameras. |
| 0.050mm | Standard setting for 65mm cameras. |

8.4 Camera Control

The Hi-5 hand unit provides remote camera setup capabilities for ARRI and third-party cameras. ARRI camera control is included by default, third-party camera control requires additional licenses.

8.4.1 ARRI Camera Control

The Hi-5 hand unit provides remote camera setup capabilities for ALEXA cameras, as well as for AMIRA if combined with the Universal Motor Controller UMC-4 or the cforce mini RF lens motor. This does not require an additional license. The following functions are supported:

- Full Playback Control (ALEXA Mini/Mini LF/AMIRA)
- Sensor Frame Rate
- Shutter Angle
- Exposure Index
- White Balance
- ND Filter (ALEXA Studio and ALEXA Mini/Mini LF/AMIRA)
- Peaking on Monitor Output (on/off)
- Surround View on Monitor Output (on/off)
- False Color on Monitor Output (on/off)
- Status Info on Monitor Output (on/off)
- Frame Lines on Monitor Output (on/off)
- User Buttons
- Camera User Setups (ALEXA Mini/Mini LF)

8.4.2 RED Camera Control

RED camera control is available with Hi-5 and the Radio Interface Adapter RIA-1 as well as the cforce mini RF lens motor (SUP 2 onwards). It requires the RED Camera Control License Key installed on Hi-5.

The RED Camera Control License Key unlocks remote control of frame rate, shutter angle, ISO, white balance, playback and camera user buttons. Supported features depend on camera model and camera settings.

8.4.3 Sony Camera Control

Camera control for Sony Venice is available with Hi-5 and the Radio Interface Adapter RIA-1 as well as the cforce mini RF lens motor (SUP 2 onwards). It requires the Sony Camera Control License Key installed on Hi-5.

The Sony Camera Control License Key unlocks remote control of frame rate, shutter angle, ISO, white balance, ND filters, playback and camera user buttons. Supported features depend on camera model and camera settings.

9 Connecting to the ECS Sync App

The ARRI ECS Sync App runs on iOS devices and can be downloaded from the App Store for free. It provides the following functions:

- Managing, visualizing and sharing lens files
- Managing and sharing Hi-5 user setup files
- Performing software updates on Hi-5 and connected LBUS devices
- News and FAQs

The ECS Sync App connects to Hi-5 via Bluetooth. To add your Hi-5 to the list of Bluetooth devices on your iOS device, do the following:

1. Go to *MENU > System > Bluetooth*.
2. Activate Bluetooth on your iOS device and add the Hi-5 to your device list (Hi-5 is shown as hi-5-xxxxx, with xxxxx being the serial number).
3. Open the ECS Sync App. The app is now connected to your Hi-5 hand unit.

10 Lens Programming

Lens files are needed to generate lens data for the Lens Data Display, focus mapping to premarked focus rings, focus tracking and as metadata in mixed reality or post production.

Follow these steps to program a lens file:

1. Go to *LDD > Lens > Lens Programming*.
2. Calibrate the lens motors or skip calibration if they are calibrated already.
3. Follow the on-screen guidance and enter the lens brand, type and focal length, serial number and focus unit.
4. Select the *Focus*, *Iris* or *Zoom* axis to enter the data points.

Use the *FUNC* button to toggle through the available options:

add	Add a value
value	Show the value on the <i>Lens data Display</i>
line	Show the line on the <i>Lens data Display</i>
snap	Snap to the nearest value to the current position of the control element.
move	Move a single mark.
offset	Move the whole scale.
delete	Delete a selected mark.
back	Quit programming a scale without saving.
finish	Finish programming the axis.

11 Lens File Management

Hi-5 contains an internal memory space for storing lens files. There are two ways of exchanging lens files with external devices:

- 1 ECS Sync app (iOS)
- 2 USB-C interface

Transferring Lens Files from Hi-5 to App

Connect Hi-5 with the ECS Sync App. Then do the following:

1. Open the ECS Sync App.
2. Go to the *ARRI Device* tab.
3. Tap on the icon of the connected Hi-5.
4. Go to *Lens Files* and mark the checkboxes of the lens files to be transferred.
5. Tap on the *Download* icon on the lower left of the app screen.
6. Select the location you want to download the files to in your app. This can be the app's root folder, an existing folder or you can create a new folder.
7. Tap on "Download here" to perform the download.

Transferring Lens Files from App to Hi-5

Connect Hi-5 with the ECS Sync App. Then do the following:

1. Open the ECS Sync App.
2. Go to the *Phone* tab.
3. Mark the checkboxes of the lens files you want to transfer.
4. Tap on the *Upload* icon on the lower left of the app screen.
5. Select the *Lens Files* folder.
6. Tap on "Upload here" to perform the upload.

Transferring Lens Files from External Flash Drive to Hi-5

Connect an external flash drive to the USB-C connector. Then do the following:

1. On the *Lens Data Display*, press *Lens*.
2. Select *Lens Files*.
3. Press the FUNC button to enter the second function level.
4. Select *External Lens Files*.
5. Select the lens files you want to import.
6. Press *import* to import the selected lens files to the internal memory of Hi-5.

Transferring Lens Files from Hi-5 to External Flash Drive

Connect an external flash drive to the USB-C connector. Then do the following:

1. On the *Lens Data Display*, press *Lens*.
2. Select *Lens Files*.
3. Press the FUNC button to enter the second function level.
4. Select *Internal Lens Files*.
5. Select the lens files you want to export.
6. Press the FUNC button to select whether to *copy*, *move* or *erase* the selected lens files.
7. If you have selected *copy* or *move*, then press the FUNC button again to decide whether to *export* the lens files to the ARRI/Hi-5/LDA folder on the external drive or if you want to *add* a new folder on the external drive to store the files in.
8. Create a new sub-folder if needed and press *export* to export the files to the selected folder on the external drive.

12 Using Smart Focus Rings

ARRI's Smart Focus Rings are a set of premarked focus rings that include a chip containing information about the premarked scale on the ring.

Smart Focus Rings can be automatically detected by the Hi-5 hand unit. To use a Smart Focus Ring, do as follows:

1. Go to *MENU > Premarked Ring* and press *auto*.
2. Slide the ring onto the knob so that the notch on the ring meets the registration pin on the knob.

The ring will be automatically detected by the Hi-5 hand unit.

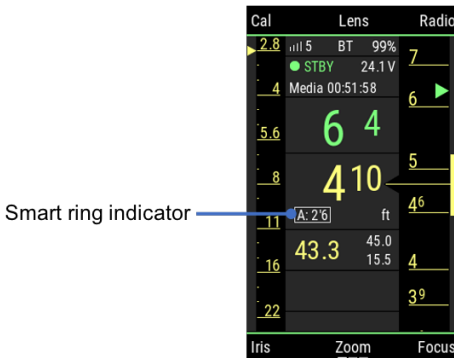

ADVICE

Focus mapping to premarked rings requires lens data. Use an LDS lens or load a lens file for lens mapping.

13 Override Mode

The *Override* function enables operators to override and return focus, iris or zoom control at the touch of a button on the Operator Control Unit OCU-1 or the Master Grips.

The Hi-5 indicates the *Override* mode and enables a smooth transition.



OCU-1/Master Grip overrides focus control from Hi-5. Hi-5 focus scale turns red. Hi-5 has no control over focus axis.



Return focus control to Hi-5 on the OCU-1/Master Grip or by pressing the F-OVR button on the Hi-5. The Hi-5 focus scale turns green. The focus knob is still offset (see motor trail at the currently set motor position).

Pull the motor trail towards the index line by turning the focus knob until the trail disappears. The Hi-5 re-engages with the lens motor.

14 Appendix

14.1 Hi-5 Sets and Accessories

Hi-5 Sets

- K0.0040721 Hi-5 Hand Unit Basic Set
- K0.0040726 Hi-5 RX-TX 2400 Set
- K0.0040724 Hi-5 RX-TX 900 Set
- K0.0040727 Smart Focus Ring Set Feet
- K0.0040728 Smart Focus Ring Set Meter

Hi-5 Parts

- KK.0039973 Hi-5 Hand Unit Body Kit
- K2.0037280 Hi-5 Hand Unit Body Naked
- K2.0039959 Hi-5 Neck Strap
- K2.0039958 Hi-5 Hand Strap
- K2.0037880 Hi-5 Monitor Bracket
- K2.0039965 RF-Cover
- K2.0039838 Bluetooth Dongle
- K2.0040015 Hi-5 Panzer Glass

Hi-5 Licenses

- 10.0040582 RED Camera Control License Key for Hi-5
- 10.0040584 Sony Camera Control License Key for Hi-5
- 10.0040585 Focusbug License Key for Hi-5
- 10.0040586 Cinefade License Key for Hi-5

Hi-5 Power Supply

K2.0036022 Li-Ion Battery Back LBP-3500

K2.0039874 LBP Battery Charger

Smart Focus Rings for Hi-5

K2.0037463 Smart Focus Ring Blank

K2.0040120 Smart Focus Ring 9"

K2.0040121 Smart Focus Ring 1'

K2.0040122 Smart Focus Ring 1'3

K2.0040123 Smart Focus Ring 1'8

K2.0040280 Smart Focus Ring 2'

K2.0040124 Smart Focus Ring 2'6

K2.0040125 Smart Focus Ring 3'6

K2.0040126 Smart Focus Ring 5'

K2.0040127 Smart Focus Ring 6'6

K2.0040128 Smart Focus Ring 10'

K2.0040110 Smart Focus Ring 0.20m

K2.0040111 Smart Focus Ring 0.25m

K2.0040112 Smart Focus Ring 0.30m

K2.0040113 Smart Focus Ring 0.35m

K2.0040114 Smart Focus Ring 0.50m

K2.0040115 Smart Focus Ring 0.75m

K2.0040116 Smart Focus Ring 1.00m

K2.0040117 Smart Focus Ring 1.50m

K2.0040118 Smart Focus Ring 2.00m

K2.0040119 Smart Focus Ring 3.00m

Hi-5 Radio Modules

K2.0033702 RF-EMIP Radio Module 2400 MHz DSSS

KK.0039985 RF-EMIP Radio Module 2400 MHz DSSS Set
(2x)

K2.0036598 RF-2400 Radio Module 2400 MHz FHSS

KK.0039984 RF-2400 Radio Module 2400 MHz FHSS Set (2x)

K2.0036599 RF-900 Radio Module 900 MHz FHSS

KK.0039986 RF-900 Radio Module 900 MHz FHSS Set (2x)

Radio Interface Adapter RIA-1

K2.0036186 Radio Interface Adapter RIA-1

K2.0039465 RIA-1 Bracket

KK.0039980 Radio Interface Adapter RIA-1 Set

K2.0034580 Cable CAM (7p) - LCS (5p)

14.2 Dimensions and Weight

Hi-5 Body Front and Side

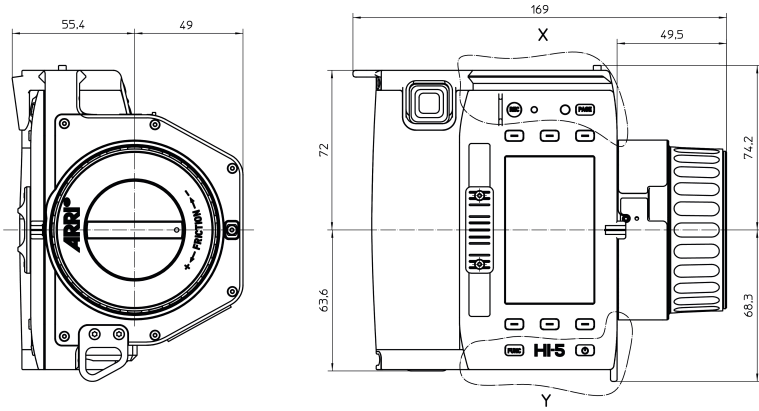

X

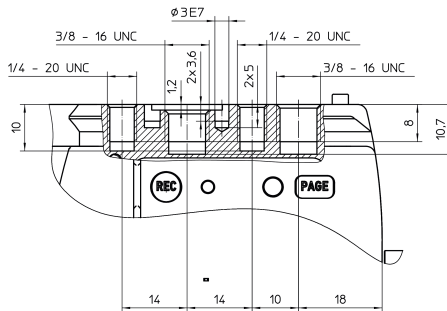

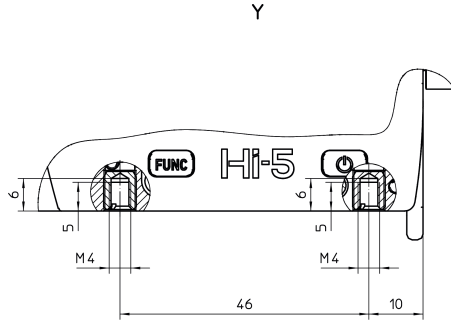

Hi-5 Body Top

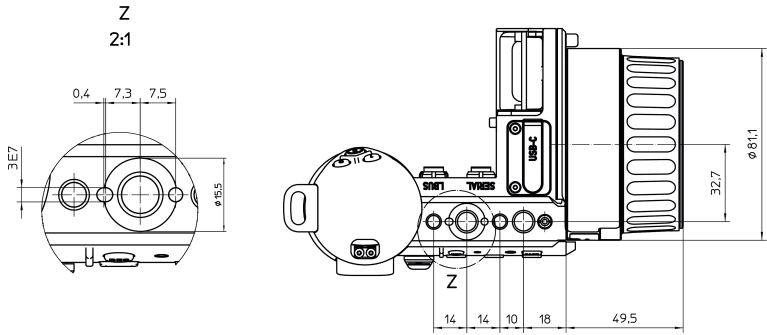

Hi-5 Body Bottom

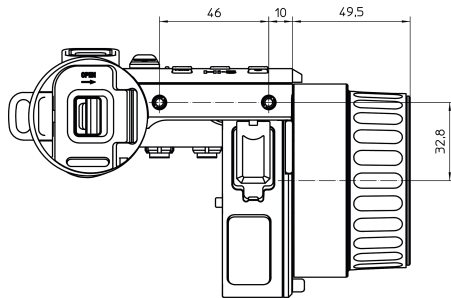

Hi-5 Body with RF-900

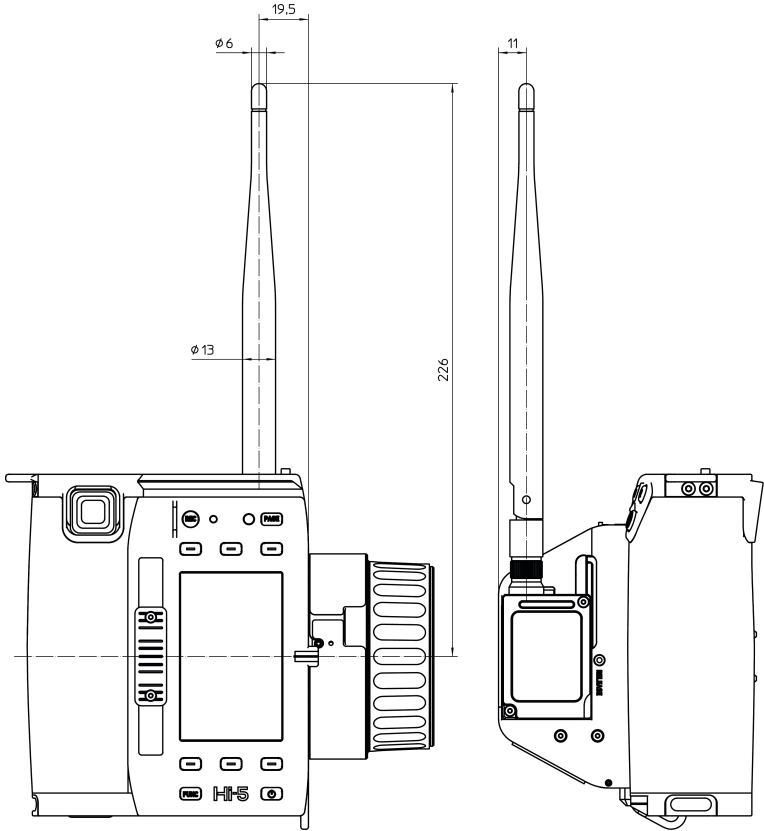

Hi-5 Body with RF-EMIP/RF-2400

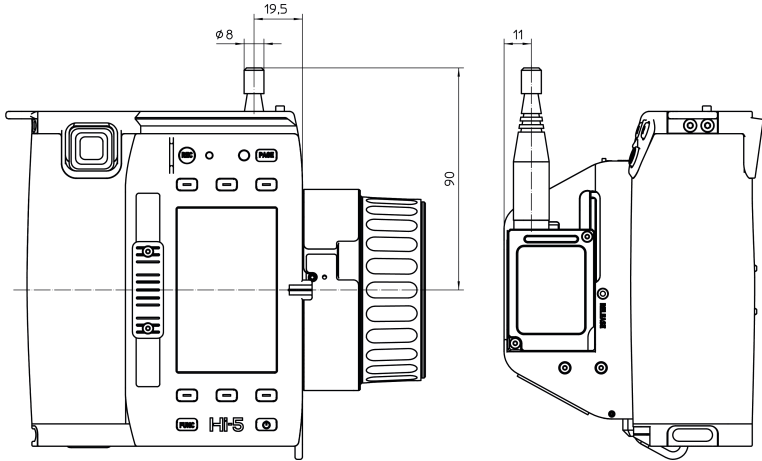

Weight

Hi-5 body with Bluetooth Dongle and Smart Focus Ring Blank:
830 g

14.3 Electrical Data

Supply Voltage

LBUS interface:	10.5V - 34.0V
Battery	7.4V

Power Consumption

Power consumption with full display/LED brightness and charged capacitor:

Without radio module:	222mA @ 7.4V
With RF-EMIP radio module:	typ. 270mA @ 7.4V
With RF-2400 radio module:	typ. 370mA @ 7.4V

With RF-900 radio module @ 100mW: typ. 330mA @ 7.4V

With RF-900 radio module @ 1W: typ. 480mA @ 7.4V

LBUS Connector

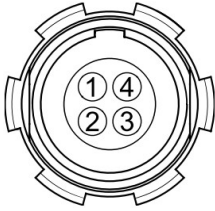

1	GND	Ground
2	CAN-L	CAN bus
3	V-BAT	Power supply in-/output
4	CAN-H	CAN bus

SERIAL Connector

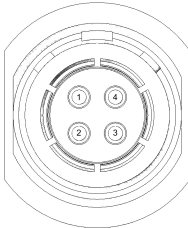

1	RX	RXD (DTE) / B
2	VCC	Power ouput (6.5-35V)
3	TX	TXD (DTE) / A
4	GND	Ground

14.4 Environmental

Temperature range (operational): -20 to +50°C (-4° to +122° F)

14.5 Service Mode

The Hi-5 has a web interface offering control over most Hi-5 functions. It includes a service mode for testing buttons, LEDs and sensors, as well as calibrating the sensors of the focus knob, iris slider and Force-Pad. This particularly fixes a potential

non-linearity of the focus knob that can cause a misalignment with pre-marked focus rings and hand-marked rings that are exchanged between various Hi-5 units.

ADVICE

Do **ONLY** use the service mode if you experience issues and need to re-calibrate the Hi-5 control elements! Make sure that you understand the calibration procedure before using it.

To access the web interface, proceed as follows:

1. Connect Hi-5 and a computer via USB-C interface.
2. Open the web browser and enter the address `hi-5-xxxxx.local`, with `xxxxxx` being the serial number of the Hi-5.
3. Enter user name: `service`
4. Enter password: `access`

To enter the service mode, proceed as follows:

1. Go to the *Service* tab.
2. Select *Enable Service Mode*.
3. Proceed with testing and calibration as per the displayed instructions.

14.6 Service Contacts

Arnold & Richter Cine Technik GmbH & Co. Betriebs KG

Herbert-Bayer-Str. 10
80807 Munich
Germany
+49 89 3809 2121
Business hours:
Mo. - Fr. 09:00 - 17:00 (CET)
service@arri.de

Vienna, Austria

ARRI Cine + Video Geräte
Ges.m.b.H.
+43 1 8920107 30
service@arri.at
Business hours:
Mo. - Fr. 09:00 - 17:00 (CET)

ARRI CT Limited / London

2 Highbridge, Oxford Road
UB8 1LX Uxbridge
United Kingdom

Milan, Italy

ARRI Italia S.r.l.
+39 (02)262 271 75
info@arri.it

+44 1895 457 000
 Business hours:
 Mo. - Thu. 09:00 - 17:30
 Fr. 09:00 - 17:00 (GMT)
 service@arri-ct.com

Business hours:
 Mo. - Fr. 09:00 - 18:00 (CET)

ARRI Inc. / West Coast

3700 Vanowen Street
 CA 91505 Burbank
 USA
 +1 818 841 7070
 Business hours:
 Mo. - Fr. 09:00 am- 05:00 pm (PT)
 service@arri.com

ARRI Inc. / East Coast

617 Route 303
 NY 10913 Blauvelt
 USA
 +1 845 353 1400
 Business hours:
 Mo. - Fr. 08:00 am - 05:30 pm (EST)
 service@arri.com

ARRI Canada Limited

1200 Aerowood Drive, Unit 29
 ON L4W 2S7 Mississauga
 Canada
 +1 416 255 3335
 Business hours:
 Mo. - Fr. 08:30 am - 05:00 pm (EDT)
 service@arri.com

ARRI Australia Pty Ltd

Level 1, Unit 1, 706 Mowbray Road
 Lane Cove
 NSW 2066 Sydney
 Australia
 +61 2 9855 43050
 Business hours:
 Mo. - Fr. 08:00 am - 05:00 pm
 (AEST)
 service@arri.com.au

ARRI China (Beijing) Co. Ltd.

Chaowai SOHO Tower C, 6/F,
 0628/0656
 Chaowai Dajie Yi 6
 Beijing
 China
 +86 10 5900 9680
 Business hours:
 Mo. - Fr. 09:00 am - 06:00 pm (CST)
 service@arri.cn

ARRI ASIA Limited

41/F One Kowloon, 1 Wang
 Yuen Street Kowloon Bay
 Hong Kong
 P. R. China
 +852 2537 4266
 Business hours:
 Mo. - Fr. 10:00 am - 06:30 pm (HKT)
 service@arri.cn

ARRI Brasil Ltda

Avenida Ibirapuera 2907 – Cj. 421,
 Indianópolis
 04029-200 São Paulo
 Brazil
 +55 1150419450
 Business hours:
 Mo. - Fr. 09:00 am - 05:30 pm (BRT)
 arribrasil@arri.com

Bars-Pro Ltd.

Distributor
 4-Ya Magistralnaya Ulitsa, 11/2
 123007 Moscow
 Russia
 +7 4995860299
 Business hours:
 Mo. - Sat. 10:00 - 18:00 (MSK)
 arri@bars-pro.ru

CINEOM Broadcast DMCC.

CINEOM Broadcast India Pvt. Ltd.
 C-4, Goldline Business Centre

Unit No. 2109, Jumeirah Bay Tower
X2 Cluster X
Jumeirah Lakes Towers
P.O Box 414659
Dubai, UAE
+971 (0) 45570477
Business hours:
Sa. - Th. 10:00 am- 06:00 pm
arriservice.me@cincom.com

Link Rd. Malad West
400 064 Mumbai
India
+91 (0)22 42 10 9000
Business hours:
Mo. - Sat. 10:00 am - 06:00 pm (IST)
arrisupportindia@cincom.com

LINKA İthalat İhracat ve Diş Tic.

Distributor
Halide Edip Adivar Mah. Darülaceze
Cad.
No:3 Akın Plaza Kat:5 95-96
34381 Şişli, İstanbul
Turkey
+90 2123584520
Business hours:
Mo. - Fr. 09:00 - 18:00 (EET)
service@linkgroup.com.tr

14.7 Declarations of Conformity

14.7.1 International declarations

EU-Declaration of Conformity

The product conforms to the specifications of the following European directives:

- Directive 2014/30/EU of the European Parliament and the Council of 26 February 2014 on the harmonisation of the laws of the Member States relating to electromagnetic compatibility
- Directive 2011/65/EU of the European Parliament and the Council of 8 June 2011 on the restriction of the use of certain hazardous substances in electrical and electronic equipment

The compliance with the requirements of the European Directives was proved by the application of the following standards:

- EN 55032:2015; EN 55035:2017;
- EN 50581:2012



FCC Class A Statement

Note: This equipment has been tested and found to comply with the limits for a Class A digital device, pursuant to Part 15 of the FCC Rules. These limits are designed to provide reasonable protection against harmful interference when the equipment is operated in a commercial environment. This equipment generates, uses, and can radiate radio frequency energy and, if not installed and used in accordance with the instruction manual, may cause harmful interference to radio communications. Operation of this equipment in a residential area is likely to cause harmful interference in which case the user will be required to correct the interference at his own expense.

Caution: changes or modifications to the product not expressly approved by the party responsible for compliance could void the user's authority to operate the equipment.

Industry Canada Compliance Statement

CAN ICES-003(A)/NMB-003(A)