

# Ora Bolt Through Fixing

## Installation Guide

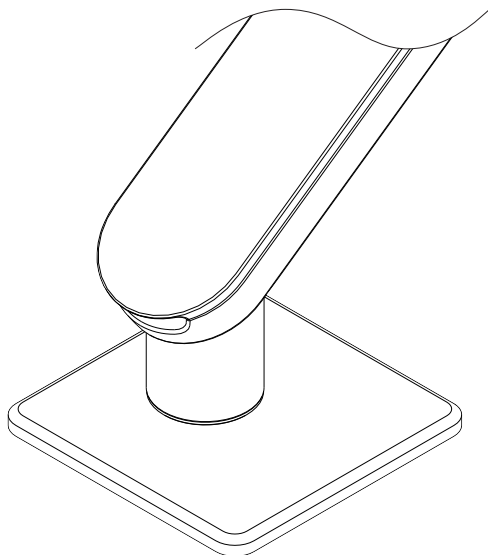

## COMPONENT CHECKLIST

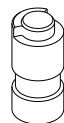

Arm Spigot (x1)

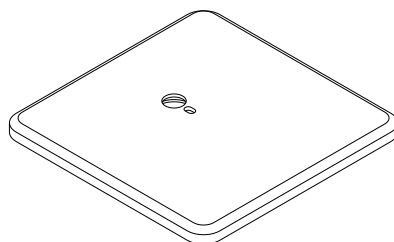

Clamp Plate (x1)

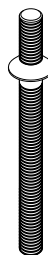

M8 Stud Bolt (x1)

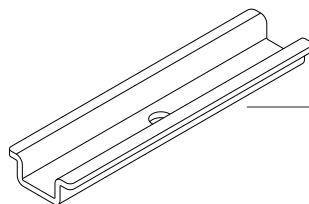

Clamp Bar (x1)



M8 Flange Nut (x1)

## CAPACITY

Weight: 2 - 8kg (4.4 - 17.6lb)  
Display Size: Up to 35" (curved or flat)  
(Larger monitors within the weight capacity may be compatible, please contact Atdec for advice).

## WARRANTY

10 Years Limited

## TOOLS REQUIRED

4mm Hex Key (supplied with Ora arm)  
8.5mm (or 11/32") drill bit  
Power Drill  
13mm Spanner  
Phillips head screwdriver

## IMPORTANT INFORMATION

- Install Ora Accessories as per these installation instructions.
- The manufacturer accepts no responsibility for incorrect installation.
- The product is compatible with grommet hole sizes up to 80mm (3.15")
- The product is compatible with desk thicknesses from 0-55mm (0-2.2").
- Do not over-tighten screws and adjustment points on product.
- This product is not suitable for outdoor use.
- Do not use this product for mobile applications.
- Please ensure desk structure and mounting surface are of sufficient strength to support this product and mounted equipment.

## ATDEC

No portion of this document or any artwork contained herein should be reproduced in any way without the express written consent of Atdec Pty Ltd. Due to continuing product development, the manufacturer reserves the right to alter specifications without notice. ©20231006

# 1 For bolt through installations, drill hole in the work surface

## 1.1

Mark out hole position on the work surface. Use Clamp Plate as a template.

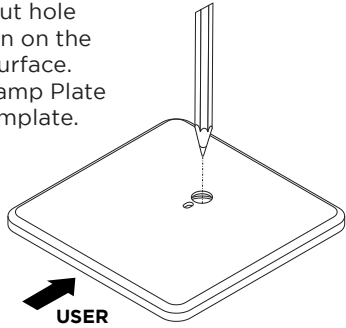

## 1.2

Drill the hole using a suitable drill bit. Ensure the hole is drilled perpendicular to the work surface and the edges of the clamp are positioned fully on the desk.

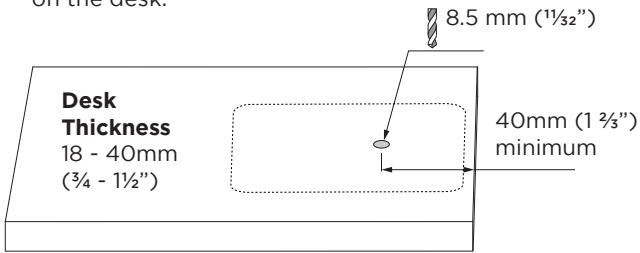

### TIP

When positioning the desk clamp, offset the clamp to the left or right of the seating position. The monitor will then be centred for the user.

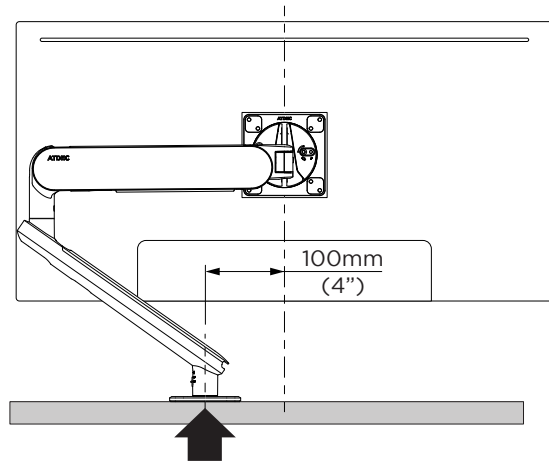

# 2 Attach Arm Spigot to Clamp Plate

## HINT!

Hold Arm Spigot and Clamp Plate together, locating the dimple in the slot, before hand tightening the screw into the spigot.

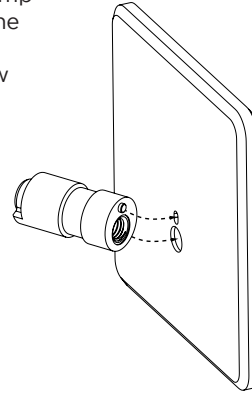

## 2.1

Screw M8 Stud Bolt through Clamp Plate into Arm Spigot.

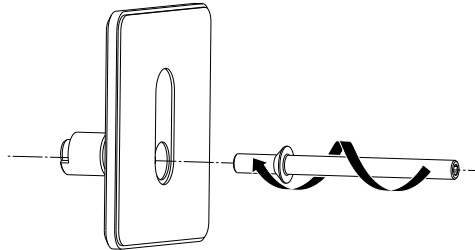

## 2.2

Tighten firmly with 4mm Hex Key supplied with Arm.

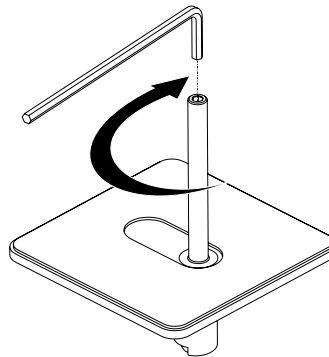

# 3 Attach plate assembly to desk

Place Clamp Bar over M8 Stud Bolt under the desk as illustrated and secure Flange Nut with spanner.

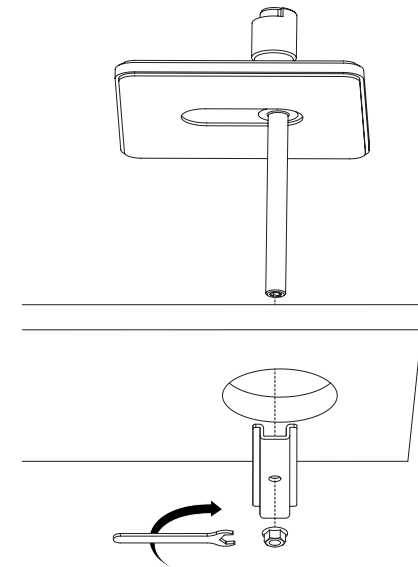

## TIP

Support plate while tightening to maintain the correct orientation on the work surface.

