

Please scan this QR code  
to visit the product page.

## MONITOR WALL MOUNT



**HAVE QUESTIONS?**

Monday - Friday from 8:00am - 4:00pm PST



[support@mount-it.com](mailto:support@mount-it.com)



(855) 925-5668



[www.mount-it.com](http://www.mount-it.com)

# Thank you for choosing Mount-It!

**EN** Read the entire instruction manual before you start installation and assembly. If you have any questions regarding any of the instructions or warnings, please contact Mount-It for assistance.

- CAUTION:** Use with products heavier than the rated weights indicated may result in instability causing possible injury.
- Mounts must be attached as specified in assembly instructions. Improper installation may result in damage or serious personal injury.
  - Safety gear and proper tools must be used. This product should only be installed by professionals.
  - Make sure that the supporting surface will safely support the combined weight of the equipment and all attached hardware and components.
  - Use the mounting screws provided and DO NOT OVER TIGHTEN mounting screws.
  - This product contains small items that could be a choking hazard if swallowed. Keep these items away from children.
  - This product is intended for indoor use only. Using this product outdoors could lead to product failure and personal injury.
- IMPORTANT:** Ensure that you have received all parts according to the component checklist prior to installation. If any parts are missing or faulty, telephone Mount-It for a replacement.
- MAINTENANCE:** Check that the bracket is secure and safe to use at regular intervals (at least every three months).

**DE** Bitte vor Beginn der Montage und Zusammenbau das ganze Handbuch durchlesen. Bitte sich mit dem Händler vor Ort bei Fragen zur Anleitung oder Warnungen in Verbindung setzen.

- VORSICHT:** Bei Verwendung mit Produkten, die das zulässige Gewicht überschreiten, können Schäden oder möglicherweise Verletzungen die Folge sein.
- Halterungen sollen entsprechend den Montageanweisungen angebracht werden. Eine unsachgemäße Montage kann Schäden oder Verletzungen zur Folge haben.
  - Sicherheitsausrüstung und geeignete Werkzeuge verwenden. Die Montage des Produktes sollte nur von Fachleuten durchgeführt werden.
  - Die tragenden Oberflächen sollten das gesamte Gewicht von Geräten und allen zusätzlichen Bauteilen sicher aushalten können.
  - Nur die mitgelieferten Einbauschrauben verwenden und die Schrauben NICHT ZU FEST ANZIEHEN.
  - Dieses Produkt enthält Kleinteile, die Erstickungsgefahr beim Verschlucken hervorrufen können. Diese Teile von Kindern fernhalten.
  - Dieses Produkt nur in Innenräumen verwenden. Verwendung des Produktes im Außenbereich kann zu Verletzungen und Schäden führen.
- WICHTIG:** Vor der Montage bitte alle erhaltenen Bauteile mit der Bauteilliste abgleichen. Bei beschädigten oder fehlenden Teilen den Händler vor Ort nach Ersatzteilen fragen.
- WARTUNG:** Die Halterungsklammer regelmäßig auf Sicherheit und Stabilität prüfen (am besten alle drei Monate).

**FR** Lisez entièrement le guide d'utilisateur avant de commencer l'installation et le montage. Si vous avez des questions concernant les instructions ou les avertissements, veuillez contacter votre distributeur local pour une assistance.

- ATTENTION:** L'utilisation de produits plus lourds que les poids nominaux indiqués peut entraîner une instabilité causant des blessures potentielles.
- Les supports doivent être joints comme spécifié dans les instructions de montage. Une mauvaise installation peut entraîner des dommages ou de graves blessures aux personnes.
  - Un équipement de sécurité et les outils appropriés doivent être utilisés. Ce produit devrait être installé uniquement par des professionnels.
  - Assurez-vous que la surface de soutien supporte en sécurité le poids combiné de l'équipement et de tous les matériaux et composants associés.
  - Utilisez les vis de montage fournies et NE SERREZ PAS TROP les vis de montage.
  - Ce produit contient de petites pièces qui peuvent causer un étouffement si elles sont avalées. Éloignez ces pièces des enfants.
  - Ce produit est prévu uniquement pour une utilisation à l'intérieur. L'utilisation de ce produit à l'extérieur peut entraîner une défaillance du produit ou des blessures aux personnes.
- IMPORTANT:** Avant l'installation, assurez-vous que vous avez reçu toutes les pièces selon la liste de vérification des composants. Si une pièce est manquante ou endommagée, téléphonez à votre distributeur local pour qu'il la remplace.
- MAINTENANCE:** A intervalles réguliers (au moins tous les trois mois) vérifiez que le support est d'utilisation sûre et fiable.

**RU** Перед началом установки и сборки прочитайте руководство по установке. Если у Вас возникли какие-либо вопросы относительно инструкций или предупреждений, свяжитесь с Вашим местным распространителем для получения помощи.

- Внимание:** Использование продуктов, вес которых превышает указанный расчетный вес, может привести к нестабильности и возможным повреждениям.
- Стелы должны быть установлены, как это показано в монтажных инструкциях. Неправильная установка может привести к получению серьезных травм.
  - Необходимо использовать предохранительное устройство и специальные инструменты. Продукт должен устанавливаться только профессионалами.
  - Убедитесь, что несущая поверхность выдержит вес оборудования и всего установленного оборудования и комплектующих.
  - Необходимо использовать чашку в комплекте установочные шурупы и НЕ ПЕРЕТИГАЙТЕ установочные шурупы.
  - Данный продукт содержит мелкие детали, которые представляют опасность удушья при проглатывании. Такие детали необходимо хранить в недоступном для детей месте.
  - Данный продукт предназначен только для эксплуатации в помещении. Использование данного продукта на улице может привести к поломке продукта и получению травм.
- ВАЖНО:** Перед установкой убедитесь, что Вы получили все детали в соответствии со списком комплектующих. Если не хватает каких-либо деталей или они повреждены, свяжитесь с Вашим местным распространителем по вопросу замены.
- ТЕХНИЧЕСКОЕ ОБСЛУЖИВАНИЕ:** Необходимо регулярно проверять (как минимум, раз в три месяца), чтобы кронштейн был зафиксирован, и его использование было безопасным.

**ES** Lea todo el manual de instrucciones antes de comenzar la instalación y ensamble de la unidad. Si tiene alguna inquietud con respecto a las instrucciones o advertencias, comuníquese con su distribuidor local.

- PRECAUCIÓN:** utilizar con productos de mayor peso al indicado en los límites de peso podría ocasionar inestabilidad y posibles heridas personales.
- Los soportes deben acoplarse tal como se indica en las instrucciones de ensamble. Una incorrecta instalación podría ocasionar daños y serias heridas personales.
  - Utilice las herramientas y equipo de seguridad adecuados. Este producto solo debe ser instalado por profesionales.
  - Assegure de que la superficie de fijación sostenga de manera segura el peso total del equipo y todos sus componentes y hardware.
  - Utilice los tornillos de ensamble suministrados y NO aplique demasiada tensión a los tornillos.
  - Este producto contiene piezas pequeñas que representan un riesgo de asfixia. Mantenga estas piezas fuera del alcance de los niños.
  - Este producto está diseñado para uso en interiores solamente. Utilizar este producto en exteriores podría ocasionar fallas y heridas personales.
- IMPORTANTE:** Assegure de que haya recibido todas las piezas según la lista de verificación de componentes para la instalación. Si falta alguna de las partes, o está dañada, comuníquese con su distribuidor.
- MANUTENIMIENTO:** Compruebe periódicamente que el soporte esté asegurado y listo para usar (al menos cada tres meses).

**PT** Leia todo o manual de instruções antes de iniciar a instalação e montagem. Se você tiver alguma dúvida sobre quaisquer uma das instruções ou avisos, por favor, entre em contato com o seu distribuidor local para assistência.

- ATENÇÃO:** O uso com produtos mais pesados do que os pesos indicados pode resultar em instabilidade, causando possíveis danos.
- Os suportes devem ser anexados como especificado nas instruções de montagem. A instalação incorreta pode causar danos ou sérias lesões pessoais.
  - Equipamentos de segurança e ferramentas adequadas devem ser utilizadas. Este produto só deve ser instalado por profissionais.
  - Certifique-se que a superfície de suporte suportará com segurança o peso combinado do equipamento e todas as ferragens e componentes anexados.
  - Use os parafusos de montagem fornecidos e NÃO APERTE EXCESSIVAMENTE os mesmos.
  - Este produto contém pequenas peças que podem causar asfixia se ingeridas. Mantenha esses itens longe do alcance de crianças.
  - Este produto destina-se somente para uso interno. Usá-lo em ambiente externo pode causar falhas no produto e lesões pessoais.
- IMPORTANTE:** Assegure-se que você recebeu todas as peças, de acordo com a lista de componentes, antes da instalação. Se alguma peça estiver faltando ou é defeituosa, contate o distribuidor local para substituição.
- MANUTENÇÃO:** Certifique-se que o suporte seja seguro e protegido para o uso em intervalos regulares (pelo menos a cada três meses).

## PACKAGE CONTENTS

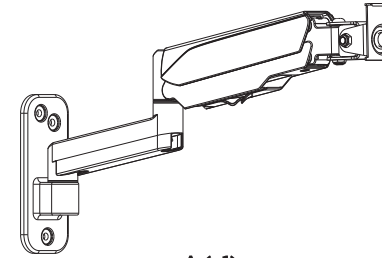

**A (x1)**  
Spring Arm



**B (x1)**  
VESA Plate



**C (x1)**  
Thumb Screw



**D (x3)**  
Decorative Cover



**E (x1)**  
6mm  
Hex Wrench

## MONITOR MOUNTING HARDWARE



**M-A (x4)**  
M4x12

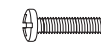

**M-B (x4)**  
M4x16



**M-C (x4)**  
M5x12



**M-D (x4)**  
M5x16



**M-E (x4)**  
D5



**M-F (x4)**

## WALL MOUNTING HARDWARE

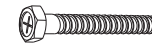

**W-A (x3)**  
ST6.3x55  
Lag Screw



**W-B (x3)**  
Ø10x45  
Concrete Anchor



**W-C (x3)**  
Washer

Missing Parts? Call us at (855) 925-5668 and we will ship replacement parts free of charge.

COMPATIBLE VESA SIZES

75x75 100x100

COMPATIBLE WITH  
TVs UP TO

32"  
MAX

Minimum weight: 1kg  
Maximum weight: 9kg



## Step 1a

### Wood Stud Mounting Option

- With a stud finder locate the stud and center the mount on the stud at the desired height. Using a bubble level to ensure straightness mark the center of the mounting holes with a pencil.
- Use a 3/16" drill bit and drill on the marked locations to a depth of 2.2". Secure the Spring Arm (#A) to the wall using Lag Screw (#W-A) and Washers (#W-C). Tighten the screws until secure.

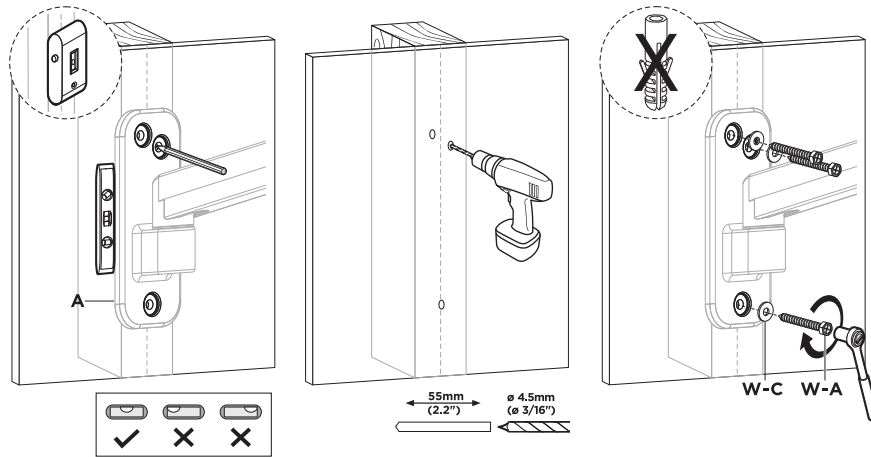

## Step 1b

### Concrete/Brick Mounting Option

- Using a bubble level to ensure straightness hold the Spring Arm (#A) to the desired location on the wall and mark the center of the mounting holes with a pencil.
- Use a 3/8" drill bit and drill on the marked locations to a depth of 2.4". Clear any dust and debris from the holes and insert the Concrete Anchors (#W-B). Secure the Spring Arm (#A) to the wall using Lag Bolt (#W-A) and Washer (#W-C). Tighten the screws until secure.

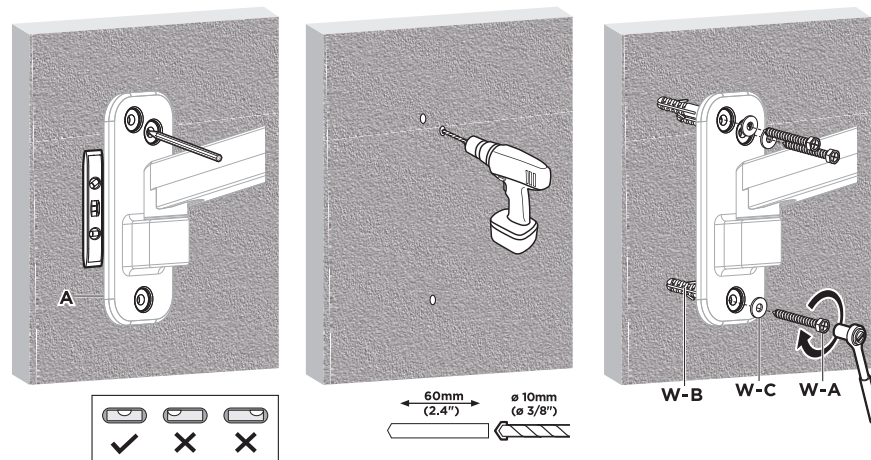

## Step 2

### Insert Decorative Covers

- Insert the Decorative Covers (#B) into each of the bolt holes.

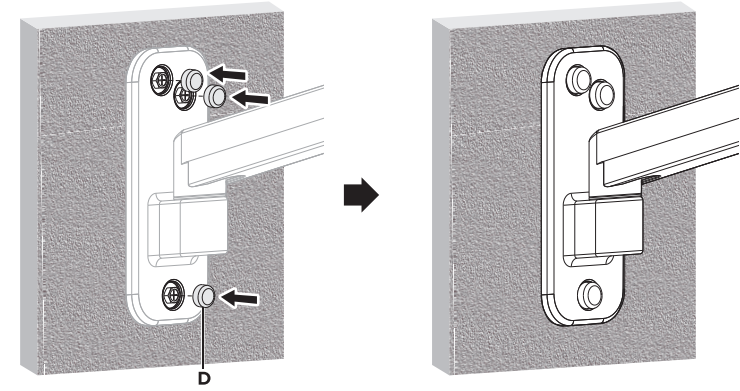

## Step 3

### Attaching the VESA Plate to the Monitor

- Select the appropriate size mounting bolt (#M-A, M-B, M-C, M-D) and Washer (#M-E) for your display's mounting holes and verify the length of the VESA bolt is not too long. If you are unsure of the correct bolt size for your display refer to your TV user manual or contact the TV manufacturer for sizing information. Connect VESA Plate (#B) to the monitor using the selected bolt, tighten until secure.
- Select the appropriate size mounting bolt (#M-A, M-B, M-C, M-D) and Washer (#M-E) for your display's mounting holes and verify the length of the VESA bolt is not too long. If you are unsure of the correct bolt size for your display refer to your TV user manual or contact the TV manufacturer for sizing information. If necessary, use the included spacers (#M-F) between the mount and the TV as shown above to adjust the length of the mounting bolt. Multiple spacers can be used in combination to achieve the desired bolt depth. Connect VESA Plate (#B) to the monitor using the selected bolt, tighten until secure.

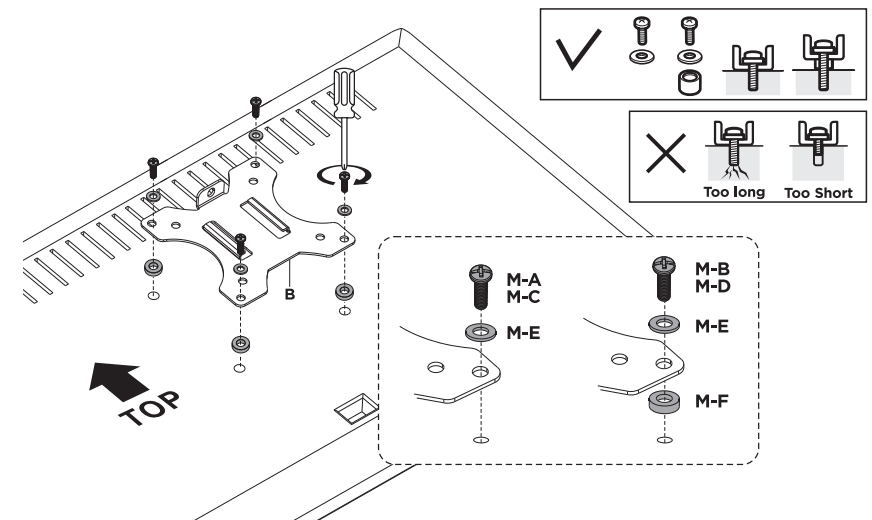

## Step 4

### Attaching the Monitor to the Spring Arm

- Slide the VESA Plate now attached to the monitor onto the end of the Spring Arm as shown. Secure the monitor to the arm using Thumb Screw (#C). Tighten the thumb screw until it is snug, do not overtighten.

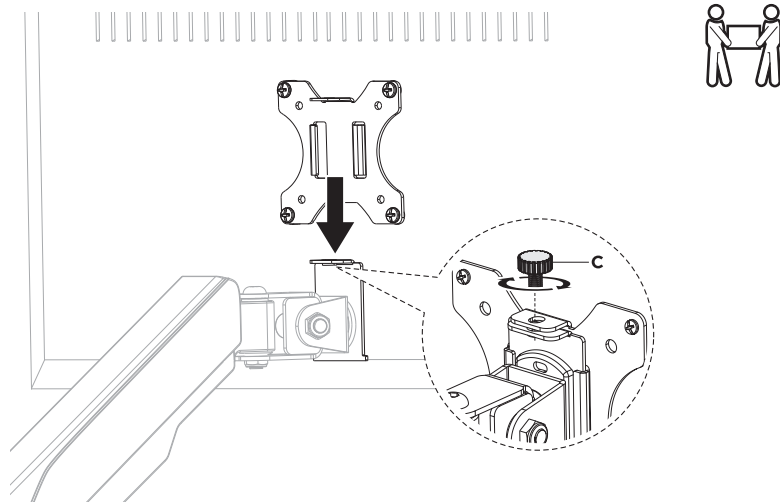

## Step 5

### Weight Balancing the Gas Spring Arm

- Gas Spring tension may need to be adjusted to suit the weight of the monitors. To weight balance the gas spring arm, begin by pushing the arm down to the lowered position. Then use Hex Wrench C to adjust the nut as pictured above, turning counterclockwise toward the + (plus) sign for heavier monitors, increasing the tension and clockwise toward the - (minus) sign for lighter monitors, lowering the tension. Adjust until the arm does not raise back to the highest position or likewise sink to the lowest position when released. This might require multiple rotations to reach the desired tension.



If the arm **drops**, turn the adjustment screw counter-clockwise until it stays in a horizontal position.

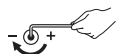

If the arm **rises**, turn the adjustment screw clockwise until it stays in a horizontal position.

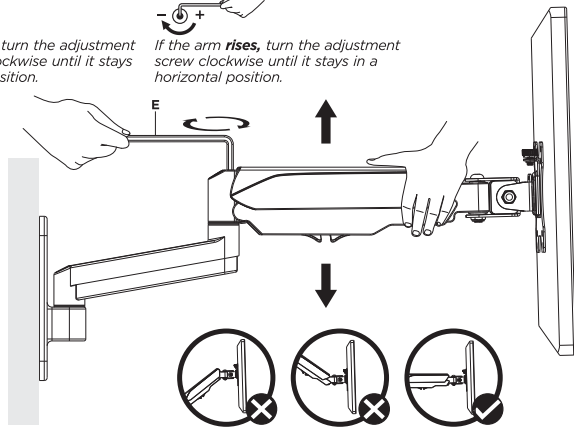

## Step 6

### Removing the Cable Management Cover

- To remove the cable management cover on the lower section of the spring arm, pull the cover straight away from the wall until it slides off the arm.
- Insert your cable into the upper arm section of the cable management system as shown, then hold the cable over the lower arm section and slide the cable management cover back into place.

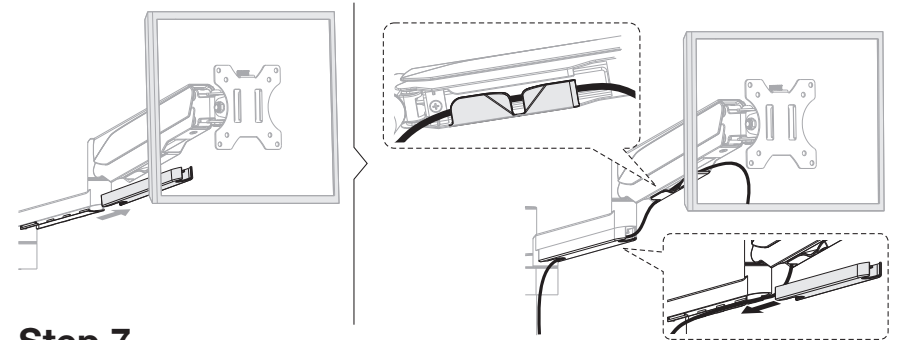

## Step 7

### Final Adjustments

- To adjust the viewing angle of the screen use Hex Wrench (#E) to loosen the bolt pictured then adjust the angle of the screen and tighten the bolt back down.

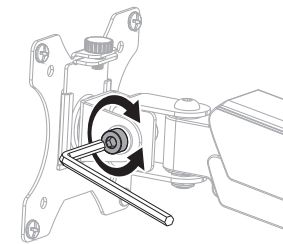

**Note:** If the display does not stop at your desired position, tighten the screws as shown.

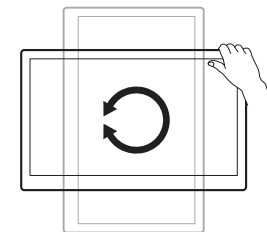
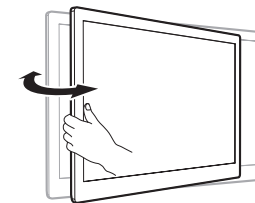
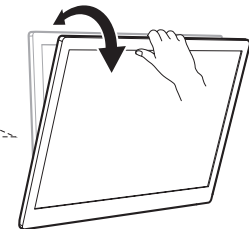

Visit us at [www.mount-it.com](http://www.mount-it.com) for product registration and warranty information.

---

Our US based customer service team is standing by to answer any questions you have about your Mount-It! product.



[support@mount-it.com](mailto:support@mount-it.com)

Available by phone **Monday - Friday from 8:00am to 4:00pm** PST.



(855) 925-5668

*Chat live with an agent on our website!*



[www.mount-it.com](http://www.mount-it.com)