

# PHANTOM 2 VISION

## User Manual V1.6

October, 2014 Revision

Congratulations on purchasing your new DJI product. Please thoroughly read the entire contents of this manual to fully use and understand the product.

It is advised that you regularly check the PHANTOM 2 VISION's product page at [www.dji.com](http://www.dji.com) which is updated on a regular basis. This will provide services such as product information, technical updates and manual corrections. Due to any unforeseen changes or product upgrades, the information contained within this manual is subject to change without notice.







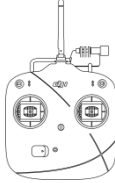
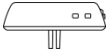
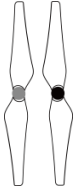

If you have any questions or concerns regarding your product, please contact your dealer or DJI Customer Service.

# Index

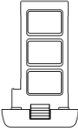
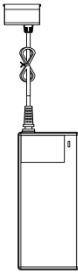
<b>INDEX</b> .....	<b>2</b>
<b>IN THE BOX</b> .....	<b>4</b>
<b>SYMBOL LEGEND</b> .....	<b>4</b>
<b>WATCH THE QUICK START VIDEOS</b> .....	<b>5</b>
<b>DOWNLOADING THE DJI VISION APP</b> .....	<b>5</b>
<b>1 ATTACHING THE PROPELLERS</b> .....	<b>6</b>
1.1 INTRODUCTION.....	6
1.2 ASSEMBLY .....	6
1.3 REMOVING THE PROPELLERS.....	6
1.4 NOTES .....	6
<b>2 INSTALLING THE RANGE EXTENDER AND MOBILE DEVICE HOLDER</b> .....	<b>7</b>
2.1 INSTALLING THE RANGE EXTENDER .....	7
2.2 INSTALLING THE MOBILE DEVICE HOLDER.....	7
<b>3 PREPARING THE REMOTE CONTROL</b> .....	<b>8</b>
3.1 THE REMOTE CONTROL .....	8
3.2 POWER ON THE REMOTE CONTROL.....	8
3.3 REMOTE CONTROL POWER INDICATOR STATUS INFORMATION.....	9
3.4 ANTENNA ORIENTATION .....	10
3.5 REMOTE CONTROL OPERATION .....	10
3.6 LINK BETWEEN THE REMOTE CONTROL AND RECEIVER .....	11
<i>Link Procedures</i> .....	12
<i>Link Indicator</i> .....	12
3.7 COMPLIANCE VERSION CONFIGURATION.....	12
<b>4 PREPARING THE RANGE EXTENDER</b> .....	<b>14</b>
4.1 THE RANGE EXTENDER.....	14
4.2 FUNCTION DESCRIPTION.....	14
4.3 POWERING ON THE RANGE EXTENDER .....	15
4.4 HOW TO BIND THE CAMERA & RANGE EXTENDER .....	15
<b>5 PREPARING THE CAMERA</b> .....	<b>18</b>
5.1 THE BUILT-IN CAMERA .....	18
5.2 MAIN FUNCTIONS .....	18
5.3 UPGRADING THE FIRMWARE OF CAMERA .....	20
<b>6 DOWNLOADING AND INSTALLING THE DJI VISION APP</b> .....	<b>21</b>
6.1 DOWNLOAD AND INSTALL.....	21
6.2 REGISTER & LOGIN .....	21
<b>7 PREPARING THE FLIGHT BATTERY</b> .....	<b>23</b>
7.1 INTELLIGENT BATTERY AND CHARGER INSTRUCTIONS .....	23
7.2 CHARGING PROCEDURES .....	23
7.3 INSTALL THE BATTERY .....	24
7.4 BATTERY USAGE.....	24
<i>Description of the Battery Level Indicator</i> .....	24
7.5 CORRECT BATTERY USAGE NOTES.....	25
<b>8 PHANTOM 2 AIRCRAFT</b> .....	<b>26</b>
8.1 THE AIRCRAFT .....	26
8.2 BUILT-IN FLIGHT CONTROL SYSTEM INSTRUCTIONS .....	26

8.3 LED FLIGHT INDICATORS DESCRIPTION.....	26
<b>9 CONNECTING TO THE CAMERA.....</b>	<b>28</b>
9.1 CAMERA CONNECTION PROCEDURES.....	28
<b>10 CALIBRATING THE COMPASS.....</b>	<b>30</b>
10.1 CALIBRATION WARNINGS.....	30
10.2 CALIBRATION PROCEDURES.....	30
10.3 WHEN RECALIBRATION IS REQUIRED.....	30
<b>11 FLIGHT.....</b>	<b>31</b>
11.1 FLYING ENVIRONMENT REQUIREMENTS.....	31
11.2 STARTING/STOPPING THE MOTORS.....	31
11.3 TAKEOFF/LANDING PROCEDURES.....	31
11.4 FAILSAFE FUNCTION.....	32
<i>Home Point</i> .....	33
<i>Dynamic Home Point</i> .....	33
<i>Go Home Procedures</i> .....	33
<i>Regaining Control During Failsafe Procedure</i> .....	34
<i>Failsafe on the DJI VISION App</i> .....	34
11.5 LOW BATTERY LEVEL WARNING FUNCTION.....	34
<i>Low Battery Level Warning on the DJI VISION App</i> .....	36
11.6 FLIGHT LIMITS.....	36
<i>11.6.1 Max Height &amp; Radius Limits</i> .....	37
<i>11.6.2 Flight Limits of Special Areas</i> .....	38
<i>11.6.3 Conditions of Flight Limits</i> .....	40
<i>11.6.4 Disclaimer</i> .....	41
<b>12 USING DJI VISION APP.....</b>	<b>42</b>
12.1 DJI VISION APP MAIN MENU.....	42
12.2 CAMERA PAGE.....	42
<i>Basic Use</i> .....	42
<i>Camera Settings</i> .....	46
12.3 ALBUM PAGE.....	49
<i>Camera SD CARD Album</i> .....	49
<i>Mobile Device Album</i> .....	50
12.4 NEWS PAGE.....	51
12.5 SETTINGS PAGE.....	52
12.6 GROUND STATION.....	55
<i>12.6.1 Ground Station GUI</i> .....	56
<i>12.6.2 Using Ground Station</i> .....	58
<b>13 ASSISTANT INSTALLATION AND CONFIGURATION.....</b>	<b>61</b>
13.1 INSTALLING DRIVER AND PHANTOM 2 VISION ASSISTANT.....	61
13.2 USING THE PHANTOM 2 VISION ASSISTANT ON A PC.....	62
13.3 FIRMWARE UPGRADE OF THE PHANTOM 2 VISION.....	63
13.4 PHANTOM RC ASSISTANT DESCRIPTION.....	64
<b>14 TROUBLESHOOTING (FAQ).....</b>	<b>66</b>
<b>15 APPENDIX.....</b>	<b>69</b>
LED FLIGHT INDICATOR STATUS.....	69
SPECIFICATIONS.....	70

## In the Box

PHANTOM 2 VISION X1 	5.8GHz Remote Control X1 	Range Extender X1 
Propeller Pair X4 	Mobile Device Holder X1 	Micro-SD Card X1 
Intelligent Battery X1 	Charger X1 	Cables X1 
Plug Set X1 	Screw X12 	Screwdriver X 1 
Assistant Wrench X1 	Accessories Box X1 	

## Symbol Legend



Forbidden(Important)



Caution





Tip



Reference

## Watch the Quick Start Videos

This user manual details installation and usage procedures of the product. In addition, we provide a range of quick start videos. It is advised that you watch them fully before attempting to use the product.

Approach 1	Direct link.	<a href="http://www.dji.com/phantom-2-vision/training">www.dji.com/phantom-2-vision/training</a>	
Approach 2	Scan the QR code to get the quick start video link.		Preparing for flight.
			How to connect to the DJI VISION App.
			The basics of flying, recording and sharing.

## Downloading the DJI VISION App





Before attempting to use the product, please download and install the DJI VISION App. Get the DJI VISION App according to the following methods.

Approach 1	Download from the App store or Google Play.	iOS user	Search "DJI VISION" from App Store.
		Android user	Search "DJI VISION" from Google Play.
Approach 2	Scan the QR code to get the download link.		Scan and download.

# 1 Attaching the Propellers

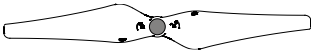
Please use the original 9-inch propellers which are classified by the color of each central nut. Damaged propellers can be replaced by purchasing new ones if necessary.

## 1.1 Introduction

Propellers	Grey Nut (9450)	Black Nut (9450 R)
Diagram		
Assembly Location	Attach to the motor thread that <b>does not have a black dot.</b>	Attach to the motor thread that <b>has a black dot.</b>
Fastening/Un-fastening Instructions	 Lock: Tighten the propeller in this direction.	 Unlock: Remove the propeller in this direction.

## 1.2 Assembly

- (Fig.1) Remove the four warning cards from the motors after you read them.
- (Fig.2) Prepare the two grey nut propellers and two black nut propellers. Make sure to match the black nut propellers with the correctly marked black dot motors. Tighten the propellers according to the fastening instructions.

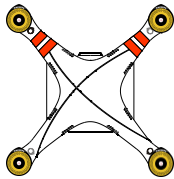

Fig.1

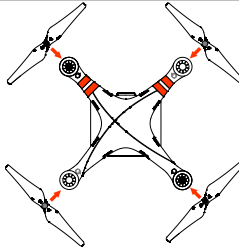

Fig.2

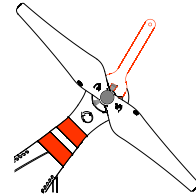



Fig.3

## 1.3 Removing the Propellers

(Fig.3) Keep the motor deadlocked in place with the assistant wrench (or one hand) and remove the propeller according to the un-fastening instructions.

## 1.4 Notes

- (1) Propellers are self tightening during flight. **DO NOT** use any thread locker on the threads.
- (2) Make sure to match the propeller nut colors with the corresponding motors.
- (3) It is advised to wear protective gloves during propeller assembly and removal.
- (4) Check that the propellers and motors are installed correctly and firmly before every flight.
-  (5) Check that all propellers are in good condition before flight. **DO NOT** use any ageing, chipped, or broken propellers.
- (6) To avoid injury, **STAND CLEAR** of and **DO NOT** touch the propellers or motors when they are spinning.
- (7) **ONLY** use original DJI propellers for a better and safer flight experience.

## 2 Installing the Range Extender and Mobile Device Holder

### 2.1 Installing the Range Extender

1. Adjust the range extender to align with the mounting bracket installed on the carrying handle.
2. Tighten the lock-screw to affix the range extender on the right side of the carrying handle.



- (1) Make sure the assembly orientation is correct with the LED side facing you.
- (2) To obtain better communication, try to keep the range extender facing the aircraft during flight.

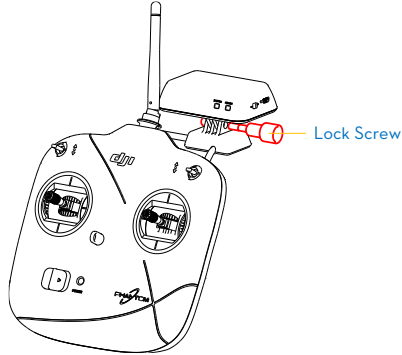

### 2.2 Installing the Mobile Device Holder

1. Tighten the Philips screws as shown to correctly attach the mobile device holder on the left side of the carrying handle.
2. Affix the mobile device sideways within the holder.



- (1) Make sure the assembly orientation is correct. The mobile device should be facing you when mounted.
- (2) It is recommended not to use oversized mobile devices (e.g. iPad), which cannot be placed into the Mobile Device Holder.

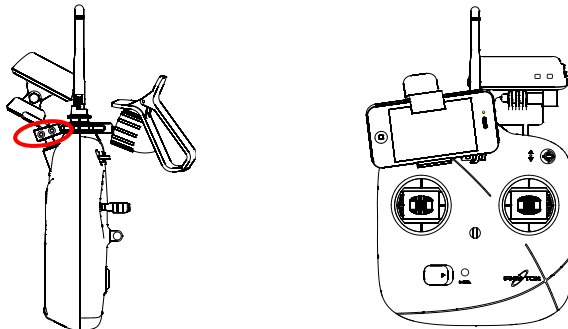

## 3 Preparing the Remote Control

The PHANTOM 2 VISION remote control is a wireless communication device that uses the 5.8GHz frequency band. It is compliant with CE and FCC (see the FCC ID) regulations and is set to Mode 2 before delivery. The compliance version can be configured by twisting the potentiometer knob on the back of the remote controller. The stick configuration can also be reset in the PHANTOM RC Assistant. Refer to the PHANTOM RC Assistant and the [Compliance Version Configuration \(Page 12\)](#) for details.

- (1) CE compliant devices have an effective communication range of 300 meters in open spaces due to power limitations. Be sure to watch your flight distance as the PHANTOM 2 VISION will enter Failsafe mode (auto-landing or go home and land) if it flies beyond this range.



- (2) FCC compliant devices have an effective range of 500 meters in open spaces. Be sure to watch your flight distance as the PHANTOM 2 VISION will enter Failsafe mode (auto-landing or go home and land) if it flies beyond this range.

- (3) Pay attention to and follow local laws and regulations.

### 3.1 The Remote Control

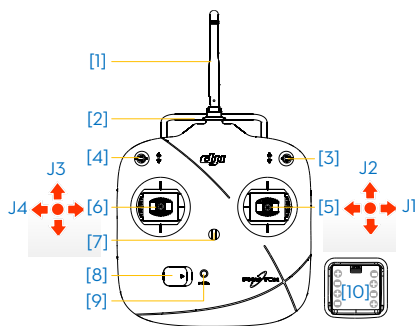

[1]	Antenna
[2]	Carrying Handle
[3]	Switch S1
[4]	Switch S2 (Reserved)
[5]	Joystick(J1: Roll [left & right], J2: Pitch [front & back])
[6]	Joystick(J3: Throttle [up & down], J4: Yaw [rotation])
[7]	Neck Strap Attachment
[8]	Power Switch
[9]	Power Indicator
[10]	Battery Compartment (On the back)

### 3.2 Power on the Remote Control

1. Install the four AA Batteries (not included) into the battery compartment on the back of the remote controller according to the negative and positive poles.
2. Set the S1 and S2 switches to the upper most position (position-1, refer to the [Remote Control Operation \(Page 10\)](#) for details) and ensure both joysticks are at the mid-point position. Then toggle on the power switch.
3. There will be a power on indicator beep. If the remote control is set to be CE compliant, then there will be one beep, while the FCC compliant version will emit two beeps. The power indicator blinks green quickly

indicating the remote controller and receiver is linking. Once fully linked, the power indicator will change to a solid green.

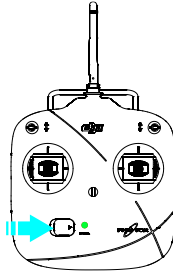

- (1) If the low voltage warning alert sounds (refer to the [Remote Control Power Indicator Status Information \(Page 9\)](#)), please replace batteries as soon as possible.
- (2) Using the incorrect type of battery may prevent a risk of damage.
- (3) Remove the batteries after use and dispose of them safely.
- (4) For long term storage, be sure to remove the batteries from the remote control.

### 3.3 Remote Control Power Indicator Status Information

Power indicator	Sound	Remote Control State
	None	Functioning normally.
	None	Establishing a link between the remote control and the receiver.
	B-B-B.....	Low voltage (at 3.9V-4.5V), should replace the batteries immediately.
	BBBB	Low voltage (lower than 3.9V). The remote control will automatically power off. Batteries should be replaced immediately.
	B-B-B.....	The remote control will display a blinking green light and sound an alarm after 15 minutes without operator input. The alarm status will disappear once you start operation of the remote control.

The remote control will blink the LED and sound an alert when the voltage drops below 3.9V and automatically power off after 3 seconds. This process will repeat even if you power cycle the remote control. If this low voltage warning occurs during flight, the remote control will automatically power off causing the aircraft to enter Failsafe mode, which cannot be interrupted (refer to the [Failsafe Function \(Page 32\)](#) for details). It is strongly recommended to replace batteries if the 3.9V-4.5V low voltage warning occurs.

### 3.4 Antenna Orientation

Try to keep the antenna pointing skyward, perpendicular to the ground, in order to achieve the maximum communication range during flight.

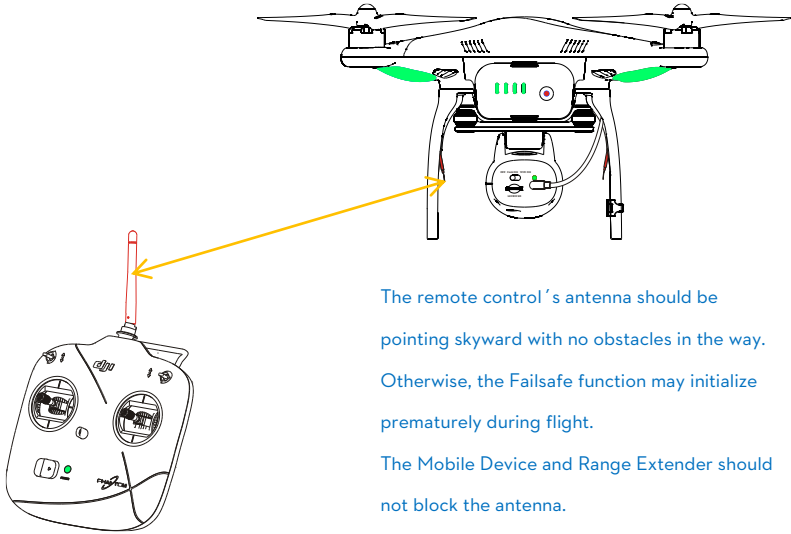

The remote control's antenna should be pointing skyward with no obstacles in the way. Otherwise, the Failsafe function may initialize prematurely during flight. The Mobile Device and Range Extender should not block the antenna.





### 3.5 Remote Control Operation

#### Definitions

The 'stick neutral' positions and 'stick released' mean the control sticks of the remote control are placed at the central position.

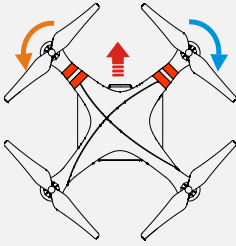
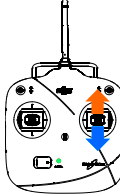
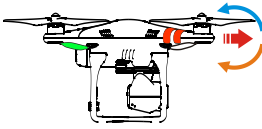
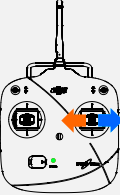
To 'move the stick' means that the stick of remote control is pushed away from the central position.

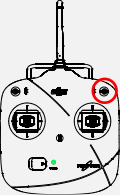
Remote Controller (Mode 2)	Aircraft ( ← nose direction )	Operation details
		<p>The throttle stick controls aircraft altitude/elevation. Push the stick up and the aircraft will rise. Pull the stick down and the aircraft will descend. The aircraft will automatically hover and hold its height if the sticks are centered.</p> <p>Push the throttle stick above the centered (mid-point) position to make the aircraft take-off. When flying, we suggest that you push the throttle stick slowly to prevent the aircraft from sudden and unexpected elevation changes.</p>

		<p>The yaw stick controls the aircraft rudder.</p> <p>Push the stick left and the aircraft will rotate counter clock-wise.</p> <p>Push the stick right and the aircraft will rotate clock-wise. If the stick is centered, the aircraft will remain facing the same direction.</p> <p>The yaw stick controls the rotating angular velocity of the aircraft. Pushing the stick further away from center results in a faster aircraft rotation velocity.</p>
		<p>The pitch stick controls the aircraft's front &amp; back tilt.</p> <p>Push the stick up and the aircraft will tilt and fly forward.</p> <p>Pull the stick down and the aircraft will tilt and fly backward. The aircraft will keep level and straight if the stick is centered.</p> <p>Pushing or pulling the stick further away from center will result in a larger tilt angle (maximum of 35°) and faster flight velocity.</p>
		<p>The roll stick controls the aircraft's left &amp; right tilt.</p> <p>Push the stick left and the aircraft will tilt and fly left.</p> <p>Push the stick right and the aircraft will tilt and fly right.</p> <p>The aircraft will keep level and straight if the stick is centered.</p> <p>Pushing the stick further away from center will result in a larger tilt angle (maximum of 35°) and faster flight velocity.</p>
	 <p>Position-1    Position-2    Position-3</p>	<p>S1 is for compass calibration. Toggle the S1 from position-1 to position-3 and back to position-1 at least 6-10 times, which will force the aircraft to enter into compass calibration mode.</p>

- (1) For 'Ready to Fly' the aircraft will hover (hold a stable horizontal position) when all sticks are released.
- (2) For 'Ready to Fly (non-GPS)' the aircraft will keep the aircraft level without horizontal positioning when all sticks are released.

### 3.6 Link between the Remote Control and Receiver

There is a 5.8G receiver in the PHANTOM 2 VISION, with the link button and indicator located on the bottom of the aircraft as illustrated in the following diagram.

The link between the remote control and aircraft is already established for you so you can initially skip this procedure. If you ever replace the remote control, re-establishing the link is required.

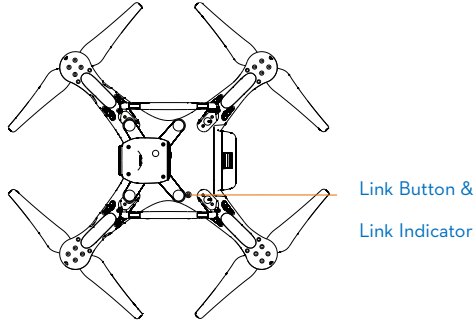

### Link Procedures

1. Power off the remote control, power on the aircraft. You will see the link indicator blinking red.
2. Press the link button with a thin object and hold until the link indicator blinks yellow. Release the link button.
3. Power on the remote control and the link indicator should switch off. This indicates that the link has been successfully established.

### Link Indicator

Link Indicator	Description	Operation
● ● ● ● ●	No signal received.	Switch on the remote control or perform a link procedure.
● ● ● ● ●	In link status.	Switch on the remote control.

### 3.7 Compliance Version Configuration

The compliance version can be reconfigured by twisting the potentiometer knob (See the following diagram) on the back of the remote control using a flathead screwdriver. For CE compliance, set the remote control to CE compliance by carefully turning the potentiometer knob to the full counter clock-wise position. For FCC compliance, set the remote control to FCC compliance by carefully turning the potentiometer knob to the full clock-wise position. Users should follow their local regulations accordingly.

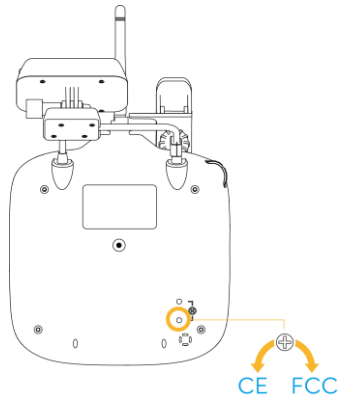

 When adjusting the potentiometer knob to its limit position, be very careful to prevent damaging the potentiometer knob. Do not apply too much force during this adjustment. Also be sure to use the correct sized screwdriver.

-  (1) It is recommended to use a flathead screwdriver of  $\Phi$  2.4mm for adjustment.
- (2) You can use the DJI screwdriver with the flathead for adjustment.
- (3) There is another potentiometer reserved.

## 4 Preparing the Range Extender

The PHANTOM 2 VISION range extender is a wireless communication device that operates within the 2.4 GHz frequency band and is used for extending the effective range of communication between a mobile device (Smartphone) and the PHANTOM 2 VISION. In an open unobstructed area, the transmission distance can reach up to 300 meters, but is usually affected by the surrounding environment, such as trees, buildings and other sources of the same frequency. Before every flight, it is suggested that you ensure the range extender functions properly. Otherwise you may experience a communication issue with the mobile device and the PHANTOM 2 VISION.

Each range extender has a unique MAC address and network name (SSID), details of which are printed on the back label as 'Phantom\_xxxxxx'. The 'xxxxxx' represents the last six letters or numbers of the MAC address for the range extender.

### 4.1 The Range Extender

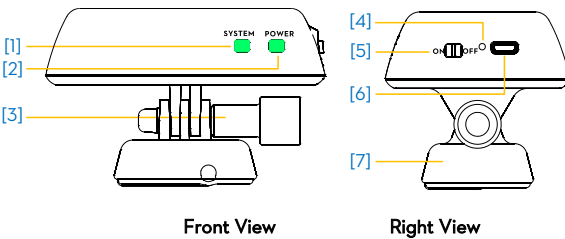

[1]	Wi-Fi Signal Indicator
[2]	Power Indicator
[3]	Lock-screw
[4]	Reset Button
[5]	Power Switch
[6]	Micro-USB
[7]	Mounting Bracket

### 4.2 Function Description

#### [1] Wi-Fi Signal Indicator (SYSTEM)

Tells you the system status of the range extender.

Wi-Fi Signal Indicator	Description
● ● ● ●	The range extender system is working normally.
Off	The range extender system is working abnormally.

#### [2] Power Indicator (POWER)

Tells you the power status of the range extender.

Power Indicator	Description
■	The range extender is working normally or completely charged.
■	Low voltage alert, a re-charge is required.
■	The range extender is charging (allow for 3-4 hours, depending on USB power output).

- (1) Make sure to charge the range extender completely before using it for the first time.
- (2) If the power indicator is a solid red light, the ranger extender may stop working at any moment. Recharge it as soon as possible.
- (3) It is recommended to charge the range extender completely before each use.
- (4) Turn off the range extender after every use.
- (5) Keep the range extender facing the aircraft during flight for the best communication link.



### [3] Lock-screw

For attaching the range extender on the right side of the remote control's carrying handle.

### [4] Reset Button:

Press to link the range extender and the camera.

### [5] Power Switch:

ON - Power on.

OFF - Power off.

### [6] Micro-USB

Used to charge the range extender.

### [7] Mounting Bracket

It has been pre-installed on the remote control's handle. It is used to attach the range extender.

## 4.3 Powering on the Range Extender

1. Toggle the power switch of range extender to ON position.
2. Wait for approximately 30 seconds. The Wi-Fi signal indicator should blink green indicating the range extender is communicating properly.



It is advised that you power off the range extender after every flight to avoid discharging the battery.

## 4.4 How to Bind the Camera & Range Extender

If the camera and range extender connection is lost, or one of them needs to be repaired or replaced, a camera and range extender binding will need to be performed via the DJI VISION App.

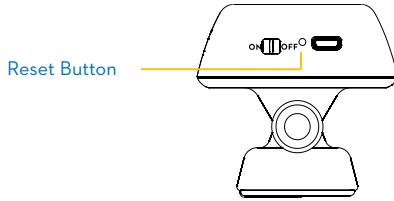

1. Power on the camera and range extender. Note: (Place the camera power switch to the 'WIFI ON' position).
2. Approximately 30 seconds later, press the reset button on the range extender with a thin object until the Wi-Fi signal indicator turns off. The range extender will then restart automatically.
3. Approximately 30 seconds later, the Wi-Fi signal indicator should start to blink green, which indicates the range extender is now ready to be bound.
4. Find and select the Phantom\_xxxxx via the Wi-Fi list on the mobile device to connect the range extender.
5. (Fig.1) Run the DJI VISION App->Settings->General->Binding. (Fig.2) Select 'Scan the QR Code' to scan the camera QR code on the product packaging. (Fig.3) Get the camera SSID (E.g. FC200\_0xxxxx) and the MAC address, select the tick  on the top right corner. The range extender should automatically restart. The binding procedure is now complete.



Fig.1

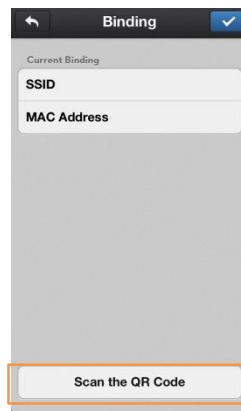

Fig.2 ( QR code is only for example. )

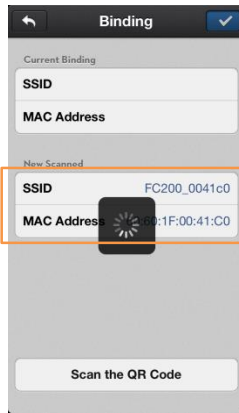

Fig.3

- (1) If both the camera and range extender are powered on and working normally, you will be able to find the SSID on the Wi-Fi list of the mobile device.
- (2) DO NOT push the reset button of the range extender unless you are ready to rebind the range extender and the camera! This will unbind your camera and you must follow the steps above to rebind.
- (3) The QR code is located on the packaging of the PHANTOM 2 VISION. If you cannot find the QR code, please contact DJI customer service to receive the QR code related to your camera's serial number.



# 5 Preparing the Camera

## 5.1 The built-in camera

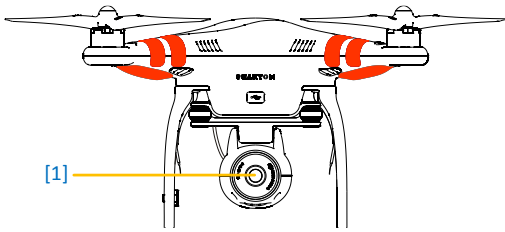

[1]	Lens
[2]	Camera Power Switch
[3]	Micro-SD Card Slot
[4]	Camera Status Indicator
[5]	Camera Cable
[6]	Capture/Record Button

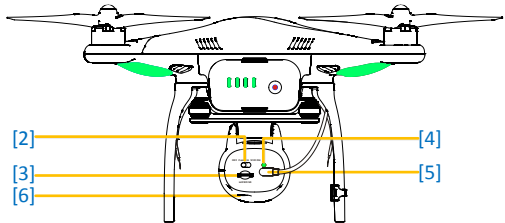

Camera Features	Specifications
Resolution	14 Megapixels
FOV	120° / 110° / 85°
Sensor size	1/2.3"
Functions	Supports multi-capture, continuous capture and timed capture Supports HD Recording (1080p30/1080i60) Supports both RAW and JPEG photo formats

## 5.2 Main Functions

### [1] Lens

For viewing and photographing, with main parameters of  $f/2.8$  , FOV 120° .

Please remove the lens cover when the camera is in use and replace the cover for storage.

### [2] Camera Power Switch (on the back of the camera)

Used to power the camera on and off.

OFF - Powered off.

CAM ON - Power on, Wi-Fi off.

WIFI ON - Power and Wi-Fi are both on. Make sure to switch to 'WIFI ON' and the range extender is powered on if using the DJI VISION App.

### [3] Micro-SD Card Slot (on the back of the camera)

Make sure that the Micro-SD card is inserted before you take any photos or record any videos.



- (1) Maximum supported Micro-SD card capacity is 32GB.
- (2) The DJI VISION App may not be able to read the Micro-SD card prepared by the user. It is suggested that you use the DJI VISION App to format the Micro-SD card when first used in the camera.
- (3) Refer to the [Camera Settings \(Page 46\)](#) for Micro-SD card formatting details.

### [4] Camera Indicator (on the back of the camera)

The Camera Indicator is used to inform the user of the working status of the camera.

Camera indicator	Wi-Fi	Camera status
Solid	OFF	Power On; Idle State
Slow Blink (0.2s on, 1.8s off)	ON	Idle State
Fast Blink (0.1s on, 0.3s off)	ON	Synchronizing photos and videos
Solid	OFF	Recording
Blink Once (0.2s on, 0.3s off)	ON/OFF	Taking a single capture
Blink 3 Times(0.1s on, 0.1s off)	ON/OFF	Taking 3 or 5 photos per shot
Fast Blink (0.1s on, 0.3s off)	ON/OFF	Firmware Upgrading
(0.2s green, 1.8s orange)	ON	Recording
Solid	ON/OFF	Critical error
Slow Blink (0.2s on, 1.8s off)	ON/OFF	CMOS sensor error
Blink Once (0.2s on, 0.3s off)	ON/OFF	Operation failed
Blink 3 Times(0.1s on, 0.1s off)	ON/OFF	Micro-SD Card error
Fast Blink (0.1s on, 0.3s off)	ON/OFF	Upgrade error
(0.5s green, 0.5s orange, 0.5s red, 0.5s Off)	ON/OFF	Camera has overheated



When camera temperature rises above 80°C, the LED indicator will blink . The camera will automatically power off if the temperature rises above 85°C.

### [5] Camera Cable (on the back of the camera)

Make sure that the camera cable is firmly attached to the camera before powering the camera on.

### [6] Capture/Record Button (on the bottom of the camera)

Capture function: Press the button once (less than 2 seconds) to take a single capture.

Record function: Press the button once (greater than 2 seconds) to begin recording. Press once again to stop.

### 5.3 Upgrading the Firmware of Camera

Follow the below instructions to update your firmware.

1. Download the latest firmware of camera from DJI website.
2. Copy the “firmware.bin” file to the root folder of your Micro-SD card.
3. Insert the SD card into the camera before turning it on.
4. Turn on the camera.
5. The firmware update will begin automatically. A yellow flashing LED indicates that the camera is updating.
6. When the yellow flashing disappears, the firmware has been updated. After a successful update, the “firmware.bin” file’s name will change to “firmware.bin.bak00”. This file can now be deleted.

(1) During the update, do not turn off the camera or take out the Micro-SD card. This may prevent your camera from switching on and will need a factory reset.



(2) A fast red flashing LED after the update means the update has failed. Please try again.

(3) For the v1.1.8 version of the PHANTOM 2 VISION Camera, PAL support has been added to the camera including 1080p25 and 960p25.

# 6 Downloading and Installing the DJI VISION App

## 6.1 Download and Install

Download and install approaches		
Approach 1	Scan the QR code to read the download link. Download and install the DJI VISION App on your mobile device. You can find the QR code on the 'Quick Start Guide' as well as on the packaging of the PHANTOM 2 VISION.	
Approach 2	iOS user	Search "DJI VISION" from App Store, download and install on your mobile device.
	Android user	Search "DJI VISION" from Google Play, download and install on your mobile device.

Supported mobile devices	
iOS (iOS6 or above)	Recommended: iPhone4s, iPhone5, iPhone5s, iPhone5C, iPod Touch4, iPod Touch5; Available but not recommended: iPad3, iPad4, iPad mini.
Android (System 4.0 or above)	Samsung Galaxy S3, S4, Note2, Note3 or mobile devices of similar configuration.

 DJI continues to support many mobile devices and any information from users are welcome. Please send any questions or queries to the following mailbox: phantom2vision@dji.com.

 Be aware that the DJI website regularly updates so make sure you visit often as well as the App Store or Google Play in order to download the latest version of the DJI VISION App.

## 6.2 Register & Login

 Access the Internet to register and login.

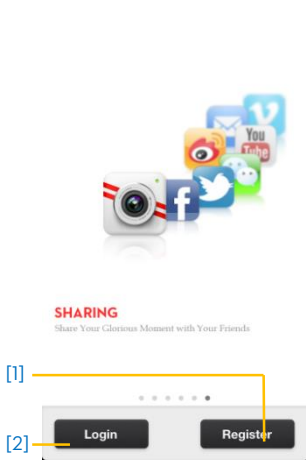

The App Welcome Page

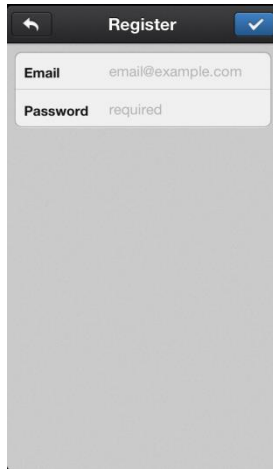

Registration Page

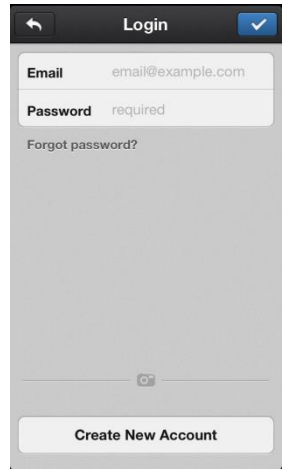

Login Page

## [1] Register

Select 'Register' to enter the registration page. Fill in your Email and Password information and then select

to create a new account.

## [2] Login

Select 'Login' to enter the login page. Fill in your registered Email and Password and then select  to login.



- (1) You should login to your account the first time you use the DJI VISION App.
- (2) If you do have an account, but forgot the password, select the "Forgot password" to retrieve it.

## [3] Usage tips

Useful tips will display when you enter the welcome page. Tap the screen to display the next useful tip.

[3]

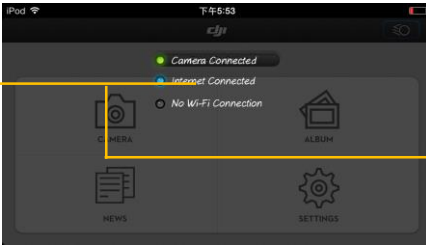

# 7 Preparing the Flight Battery



Before use, please read and follow the user manual, disclaimer, and the warnings on the battery.

Users take full responsibility for all operations and usage.

## 7.1 Intelligent Battery and Charger Instructions

The intelligent battery is specially designed for the PHANTOM 2 VISION, with a battery capacity of 5200mAh, voltage of 11.1v and charge-discharge management functionality. The battery should only be charged with the charger provided by DJI. DJI does not take any responsibility for operation of any charger from a third party.

There are many features provided by the DJI charger:

- Balance charge protection
- Full charge protection
- Short circuit protection
- Output protection
- Sleep protection
- Overheating protection

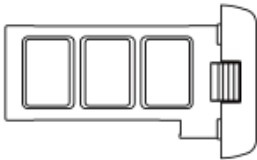

Intelligent Battery

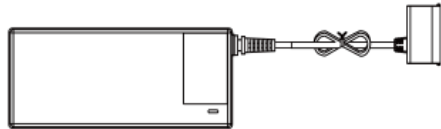

Charger

## 7.2 Charging Procedures

1. Connect the battery to the charger while the power is OFF.
2. Connect the charger to a wall socket. The charger indicator light will turn a solid red when it is charging.
3. Wait until the charger indicator turns solid green to which indicates that the battery is completely charged.

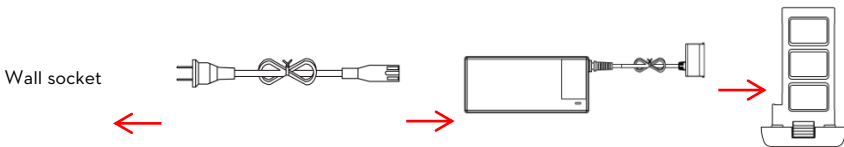

	Charger indicator	Status of charge
		Charging.
		Completely charged.

### 7.3 Install the Battery

Push the battery into the battery compartment correctly as the following diagram shows. Make sure to push the battery into the compartment until you hear a 'click' sound.

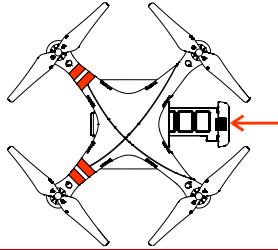

An incorrectly inserted battery may cause one of the following to occur:

- (1) Bad contact.
- (2) Unavailable battery information.
- (3) Unsafe for flight.
- (4) Unable to take off.



### 7.4 Battery Usage

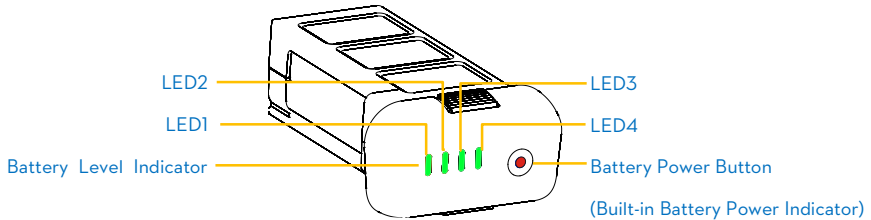

(1) **Checking the battery level:** When the battery is powered off; pressing the battery power button once will indicate the current battery level. Refer to [Description of the Battery Level Indicator \(Page 24\)](#) for details.

(2) **Powering on:** When the battery is powered off; press the battery power button once and then press and hold for 2 seconds to turn on the intelligent battery.

(3) **Powering off:** When the battery is powered on; press the battery power button once and then press and hold for 2 seconds to turn off the intelligent battery.



More battery information is available in the battery tab of the PHANTOM 2 VISION Assistant.

#### Description of the Battery Level Indicator

The current battery level is shown during both the charging and discharging process. Refer to the following table for details:

The indicators are defined below : ■ LED is on. ● LED blinks. ■ LED is off.

Battery level indicator	Current battery level
-------------------------	-----------------------

LED1	LED2	LED3	LED4	
■	■	■	■	87.5%-100%
■	■	■	●	75%-87.5%
■	■	■	■	62.5%-75%
■	■	●	■	50%-62.5%
■	■	■	■	37.5%-50%
■	●	■	■	25%-37.5%
■	■	■	■	12.5%-25%
●	■	■	■	0%-12.5%
■	■	■	■	<0%

## 7.5 Correct Battery Usage Notes

- It's suggested you purchase a new battery after you have discharged your current battery over 300 times.
- It's recommended to charge and discharge the battery thoroughly once every 20 charge/discharge cycles. Users should discharge the battery until there is less than 8% power left or until the battery can no longer be turned on. Refer to the DJI VISION App for an exact readout of the battery percentage level. You should then fully recharge the battery to maximum capacity. This power cycling procedure will ensure the battery is working at its optimal level.
- Turn the power OFF when you have finished flying and remove the battery from its compartment. NEVER plug or unplug the battery into the aircraft when it is powered on.
- Take the battery out of the aircraft after every flight and store the battery in a safe and secure place. For long term storage please place the battery with only a 40-50% capacity in a strong battery box securely. We recommend discharging and charging the battery completely once every 3 months to keep it in good condition. The capacity should be varied in such a cycle (40%-50%)—0%—100%—(40%-50%).
- Adhere to the notes for the battery in the disclaimer and regard safety as your first priority.
- The battery should be charged in an environment that is between 10°C to 40°C, and be discharged in an environment that is between -20°C to 60°C. Both charging and discharging should be in an environment that the relative humidity is lower than 80%.
- It's suggested that you purchase a new battery if the current battery is swollen or damaged in any way.
- Never try to recharge or fly with a battery that is swollen or damaged in any way.
- Never charge the battery unattended. Always charge the battery on a non-flammable surface such as concrete and never near any flammable materials.

# 8 PHANTOM 2 Aircraft

## 8.1 The Aircraft

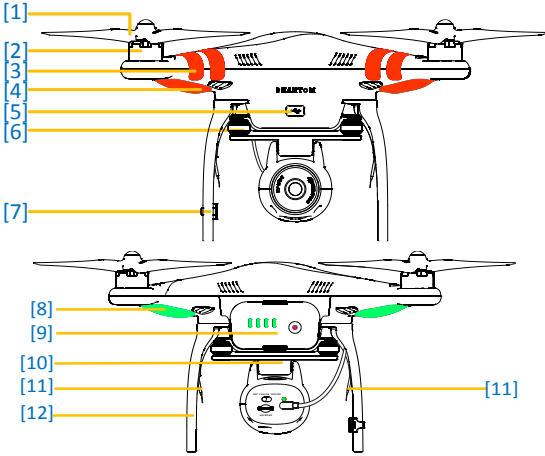

[1]	Propeller
[2]	Motor
[3]	Front Side
[4]	Front LEDs
[5]	Micro-USB
[6]	Vibration Absorber
[7]	Compass
[8]	LED Flight Indicators
[9]	DJI Intelligent Battery
[10]	Servo
[11]	Receiver Antenna
[12]	Landing Gear

## 8.2 Built-in Flight Control System Instructions

The built-in flight control system is used to control the entire aircraft's functions in flight such as Pitch (forwards and backwards), Roll (left and right), Elevator (up and down) and Yaw (turn left or right). The flight controller contains the MC (Main Controller), IMU, GPS, compass, receiver and LED indicators. The IMU (Inertial Measurement Unit) has a built-in inertial sensor and a barometric altimeter that measures both attitude and altitude. The compass reads geomagnetic information which assists the GPS (Global Position System) to accurately calculate the aircraft's position and height in order to lock the aircraft in a stable hover. The receiver is used to communicate with the remote control and the MC acts as the brains of the complete flight control system connecting and controlling all the modules together.

## 8.3 LED Flight Indicators Description

After powering on the intelligent battery, the LED flight indicators light up to show the aircraft's current status.

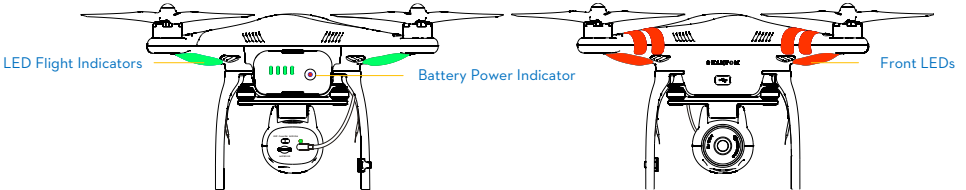

### Front LEDs

The front LEDs are for indicating where the nose of the aircraft is. They light up solid red only after the motors have started spinning.

## LED Flight Indicators Description

Normal status	LED flight indicators	Notes
Power On Self-Test		----
Warming Up		Aircraft cannot take off.
Ready to Fly		Slow blinking green.
Ready to Fly (non-GPS)		Slow blinking yellow.
Abnormal status	LED flight indicators	
Remote Control Signal Lost		Fast blinking yellow. Refer to the <a href="#">Failsafe Function (Page 32)</a> .
Low Battery Capacity Warning		Slow blinking red.
Critical Low Battery Capacity Warning		Fast blinking red.
Not Stationary or Sensor Bias is too big		Keep aircraft stationary or perform IMU calibration.
Error*		Cannot fly.
Compass Needs Calibration		Refer to the <a href="#">Calibrating the Compass (Page 30)</a> .

(1) The aircraft should be kept stationary on level ground before takeoff.

(2) Make sure the aircraft's status is in Ready to Fly or Ready to Fly (non-GPS) mode before takeoff.

(3) If an error occurs (LED is solid red), please connect to the PHANTOM 2 VISION Assistant for more detailed information.



NO.	Errors	Operation
1	IMU calibration is required.	Calibrate within the Assistant.
2	IMU is abnormal.	Should be repaired.
3	Compass is abnormal.	Should be repaired.
4	Remote Control's mid-point is set abnormally.	Refer to the <a href="#">How to solve large margin(s) mid-point error? (Page 66)</a> for details.

# 9 Connecting to the Camera

## 9.1 Camera Connection Procedures

Please carry out the following procedures to connect a mobile device to the PHANTOM 2 VISION.

1. Power on the remote control and the range extender.
2. Make sure the switch on the back of the camera is set to "WIFI ON" and then power on the PHANTOM 2 VISION.
3. (Fig.1) Enable the Wi-Fi on your mobile device; wait for about 30 seconds, and then select the Phantom\_xxxxxx from the Wi-Fi network list.
4. (Fig.2) Run the DJI VISION App on your mobile device which will indicate the current Wi-Fi connection status on the main menu. The Wi-Fi connection indicator will turn solid green which means the connection is good.
5. Tap the "CAMERA" icon and the DJI VISION App will establish a live camera preview (Fig.3). This means everything is now functioning.

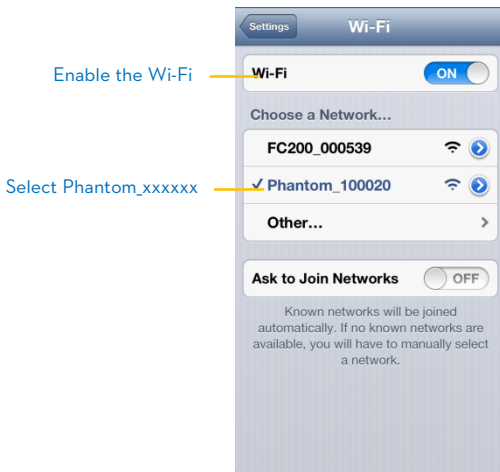

Fig.1

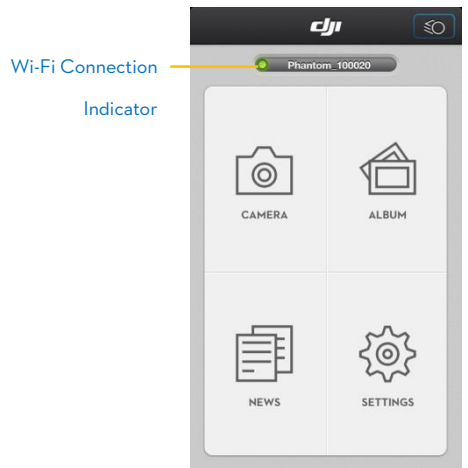

Fig.2

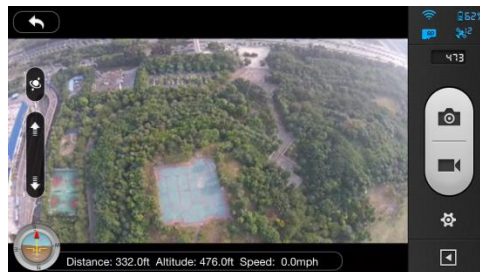





Fig.3

## Wi-Fi Connection Indicator Description

Icon		Description
	Solid green	Wi-Fi is now connected to the PHANTOM 2 VISION.
	Solid blue	Wi-Fi is connected to another Wi-Fi network and NOT to the PHANTOM 2 VISION.
	Off	No Wi-Fi connection.

(1) The first time you launch the DJI VISION App, Internet access is required to finish the login process or new account creation.



(2) The SSID is unique for each PHANTOM 2 VISION which should appear in your Wi-Fi list as Phantom\_xxxxxx. Always connect to the SSID starting with Phantom\_xxxxxx. FC200\_0xxxxx is the SSID of the camera and should not be connected to. If the SSID FC200\_0xxxxx is connected to, then the connection signal range will be extremely shortened.

# 10 Calibrating the Compass

**IMPORTANT: Make sure to perform the Compass Calibration procedures prior to the first flight.**

The compass is very sensitive to electromagnetic interference which causes abnormal compass data and leads to poor flight performance or even flight failure. Regular calibration of the compass enables the compass to perform at its optimal level.

## 10.1 Calibration Warnings

- (1) DO NOT calibrate your compass where there is a possibility for the existence of strong magnetic interference such as magnetite, parking structures, and steel reinforcement underground.
- (2) DO NOT carry ferromagnetic materials with you during calibration such as keys or cellular phones.
- (3) Compass Calibration is very important; otherwise the flight control system will not work properly.

## 10.2 Calibration Procedures

Choose an open space to carry out the following procedures. Please watch the quick start video of the PHANTOM 2 VISION for more compass calibration details.

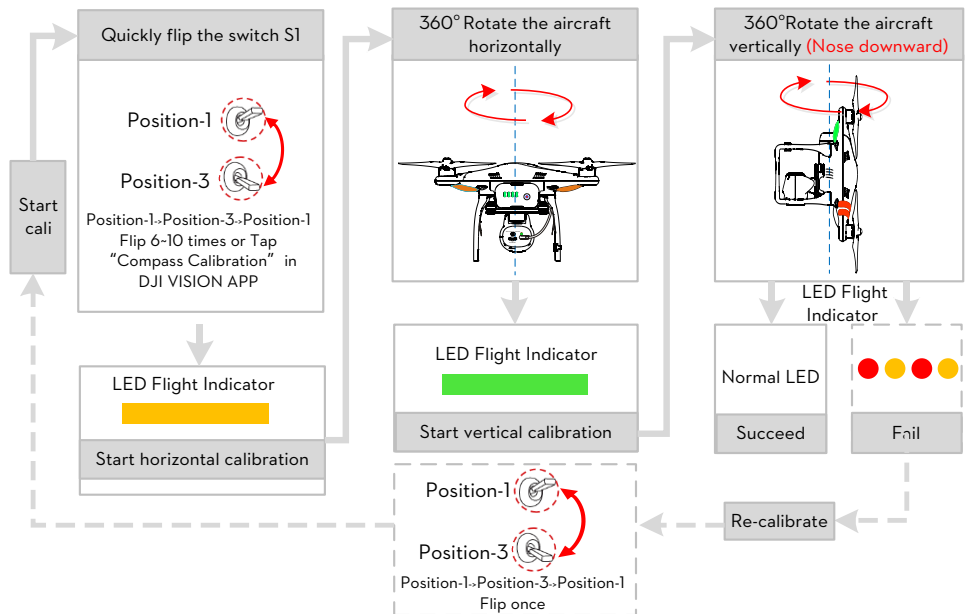

## 10.3 When Recalibration Is Required

- (1) When Compass Data is abnormal, the LED flight indicator will blink alternating between red and yellow.
- (2) Last compass calibration was performed at a completely different flying field/location.
- (3) The mechanical structure of the aircraft has changed, i.e. changed mounting position of the compass.
- (4) Evident drifting occurs in flight, i.e. the aircraft doesn't fly in straight lines.

# 11 Flight

## 11.1 Flying Environment Requirements

- (1) Before your first flight, please allow yourself some flight training (Using a flight simulator to practice flying, getting instruction from an experienced person, etc.).
- (2) DO NOT fly in bad weather, such as rain or wind (more than moderate breeze) or fog.
- (3) The flying field should be open and void of tall buildings or other obstacles; the steel structure within buildings may interfere with the compass.
-  (4) Keep the aircraft away from obstacles, crowds, power lines, trees, lakes and rivers etc.
- (5) Try to avoid interference between the remote control and other wireless equipment. (No base stations or cell towers around)
- (6) The flight control system will not work properly at the South Pole or North Pole.
- (7) All parts must be kept out of the reach of children to avoid CHOKING HAZARDS; if a child has accidentally swallowed any part, you should seek immediate medical assistance.

## 11.2 Starting/Stopping the Motors

A Combination Stick Command (CSC) is used to start the motors instead of simply pushing the throttle stick up. This is a safety precaution to prevent the motors from accidentally spinning up. Push both sticks to their bottom corners as indicated in the diagram below to start the motors. Once the motors have spun up, release both sticks simultaneously. The same combination stick command (CSC) is used to stop the motors.

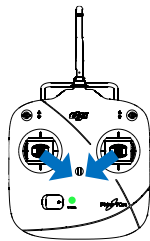

## 11.3 Takeoff/Landing Procedures

1. Start by placing the PHANTOM 2 VISION on the ground with the battery level indicator facing you.
2. Power on the remote control.
3. Power on the range extender.
4. Switch the camera to the "WIFI ON" position.
5. Power on the aircraft by turning on the intelligent battery, refer to the [Battery Usage \(Page 24\)](#) for details.
6. Connect the mobile device to the PHANTOM 2 VISION and then run the DJI VISION App to enter the camera preview page.

7. Wait until the LED flight indicator starts to slowly blink green/yellow. This means the aircraft is initializing and entering the “Ready to Fly”/“Ready to Fly (non-GPS)” state. Then proceed to execute the CSC command to start motors.
8. Push the throttle stick up slowly to lift the aircraft off the ground. Refer to the [Remote Control Operation \(Page 10\)](#) for more details.
9. Enjoy your flight while capturing and recording with the DJI VISION App. Refer to the [Using DJI VISION App \(Page 42\)](#) for more details.
10. Pull down the throttle stick to descend. The stick will lock into place and the aircraft will descend steadily.
11. After landing the aircraft on the ground, keep the throttle stick at its lowest position for about 3 to 5 seconds which will automatically stop the motors.



You SHOULD NOT execute the CSC during normal flight! This will stop the motors and cause the aircraft to descend rapidly and drop without any type of control.



- (1) When the LED flight indicator blinks yellow rapidly during flight, the aircraft has entered into Failsafe mode, refer to the [Failsafe Function \(Page 32\)](#) for details.
- (2) A low battery capacity warning is indicated by the LED flight indicator blinking red slowly or rapidly during flight. Refer to the [Low Battery Level Warning Function \(Page 34\)](#) for details.
- (3) Watch the quick start video about flight for more flight information.
- (4) Aircraft and battery performance is subject to environmental factors such as air density and temperature. Be very careful when flying 3000 meters (9800 feet) or more above sea level, as battery and aircraft performance may be reduced.

#### 11.4 Failsafe Function

The aircraft will enter Failsafe mode when the connection from the remote control is lost. The flight control system will automatically control the aircraft to return to home and land to reduce injuries or damage. The following situations would make the aircraft fail to receive a signal from the remote control and enter Failsafe mode:

- (1) The remote control is powered off.
- (2) The aircraft has flown out of the effective communication range of the remote control.
- (3) There is an obstacle obstructing the signal between the remote control and the aircraft, essentially reducing the distance the signal can travel.
- (4) There is interference causing a signal problem with the remote control.

Failsafe works differently depending on the mode the aircraft is in when Failsafe mode is initiated whether it is in the Ready to Fly or Ready to Fly (non-GPS) mode.

#### Ready to Fly (non-GPS) ---- Automatic landing

The flight control system will try to keep the aircraft level during descent and landing. Note that the aircraft may be drifting during descent and landing process.

## Ready to Fly --- Automatic go home and land

The flight control system will automatically control the aircraft to fly back to the home point and land.

### Home Point

When the aircraft is initializing the Ready to Fly status, the aircraft will record the current GPS coordinates as the home point. It is recommended to lift off only after Ready to Fly status is confirmed for the safety of being able to fly back to home point successfully in case the Failsafe mode is initiated.

### Dynamic Home Point

The Home point will be reset to position of the mobile device at specific time intervals.

- (1) Enable dynamic home point in DJI Vision app or Phantom 2 Assistant.
- (2) Dynamic home point is only available to the GPS-enabled mobile device. Turn on GPS and data service to obtain higher accuracy of the mobile device position.
- (3) Dynamic home point is useful in situations when you are in motion and require a Home point that is different from the takeoff point.

### Go Home Procedures

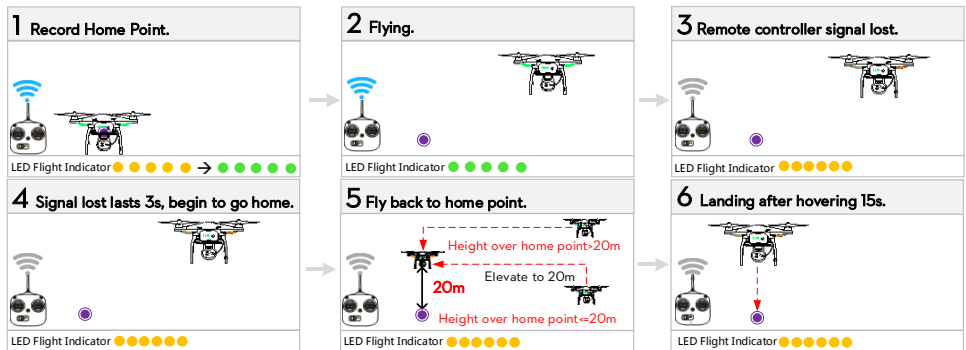

(1) In a Failsafe situation, if less than 6 GPS satellites are found for more than 20 seconds, the aircraft will descend automatically.





(2) Aircraft cannot navigate around vertical obstacles on its return home course during Failsafe. However, you can set return home altitude value in Phantom Assistant to avoid hitting vertical obstacles through DJI Phantom Assistant.



In Phantom 2 Vision mode, users can set a new home point manually when the aircraft is in "Ready to fly" status as long as a home point has been recorded automatically. Quickly flipping the S2 switch of the remote control from upper most to lower most positions 5 times or more will reset the current aircraft position as a new home point of PHANTOM 2 VISION. When successfully reset, you will see a series of rapid green blinks on the LED Flight Indicator. The definition of "home point" is: i) The home point is the place PHANTOM 2 VISION returns to when the control signal is lost, which is recorded last time. ii) The



home point is used to calculate the horizontal distance between you and the aircraft, the distance will be displayed on the DJI VISION App.

### Regaining Control During Failsafe Procedure

Position of Switch S1	 <b>Position-1</b>	 <b>Position-2</b>	 <b>Position-3</b>
How to regain control	When the S1 switch is switched to Position-1, toggle the S1 switch to any other position once to regain control. If remote control's signal is recovered, control is returned back to the pilot.	Regain control as soon as signal is recovered.	

### Failsafe on the DJI VISION App

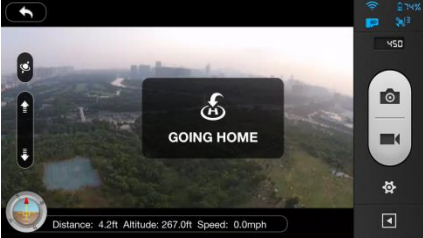







The DJI VISION App will provide information during Failsafe.

	
Control Signal Lost Indicator	Going Home Indicator
 Refer to the <a href="#">Using DJI VISION App (Page 42)</a> for details.	

### 11.5 Low Battery Level Warning Function

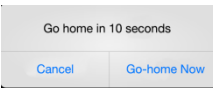
If the DJI smart battery is depleted to a point that may affect the safe return of the aircraft, the low battery level warning notifies users to take action. Users are advised to land the aircraft immediately when they observe these warnings. The thresholds for these warnings are automatically determined based on the current aircraft altitude and its distance from the Home point. Details of the battery level warning are listed below:



Battery Level Warning	Remark	Rear LED Flight Indicator	DJI VISION App	Flight Instructions
<b>Sufficient battery level</b> 	Sufficient battery level.	 Green LED blinks slowly.	No message prompts.	Operating normally, no specific action needed.
<b>Low battery level warning</b> 	The battery power is low. Please land the aircraft.	 Red LED blinks slowly.	When “Go-Home” is selected in the Phantom Assistant, this message will appear:  Tap “Go-home Now” to have the aircraft return to the Home point and land automatically, or “Cancel” to resume normal flight. If no action is taken, the aircraft will automatically go home and land after 10 seconds.	Fly the Phantom 2 Vision+ back and land it as soon as possible, then stop the motors and replace the battery.
<b>Critical Low battery level warning</b> 	The aircraft must land immediately.	 Red LED blinks quickly.	The DJI Vision App screen will flash red and aircraft starts to descend.	The Phantom 2 Vision+ will begin to descend and land automatically.
<b>Estimated remaining flight time</b> 	Estimated remaining flight based on current battery level.	N/A	N/A	N/A

- Color zones on the battery level indicator  reflect estimated remaining flight time and are adjusted automatically, according to the aircraft’s current status.
- When the critical battery level warning activates and the aircraft is descending to land automatically, you may push the throttle upward to hover the aircraft and navigate it to a more appropriate location for landing.



When these warnings are triggered, please bring the aircraft back to the Home point or land to avoid losing power during flight.

## Low Battery Level Warning on the DJI VISION App

Battery level warnings will show on the camera page of the DJI VISION App when the battery level is low.

- (1) A red light will flash along the edges of the app screen.
- (2) An audible alarm will sound. Make sure sound is turned on and volume is turned up on your mobile device.
- (3) The aircraft battery icon will turn red.



Low Battery Capacity Warning



Refer to the [Using DJI VISION App \(Page 42\)](#) for details.



- (1) Remember to fly your PHANTOM 2 VISION back as soon as you see a low battery capacity warning.
- (2) The PHANTOM 2 VISION is "Ready To Fly," "Ready to Capture" and "Ready to Share" but it is still an aircraft. Keeping the battery contact needles and pads clean is very important. Any dirt and dust may cause a communication failure.

## 11.6 Flight Limits

All UAV (unmanned aerial vehicle) operators should abide by all regulations from such organizations at ICAO (International Civil Aviation Organization) and per country airspace regulations. For safety reasons, the flight limits function is enabled by default to help users use this product safely and legally. The flight limits function includes height, distance limits.

In Ready to Fly status, height and distance limits works together to restrict the flight. In Ready to Fly (non-GPS) status, only height limit works and the flying height restricted to be not over 120m.



- (1) The default parameters in the Assistant is compliant within the definitions of class G ruled by ICAO. (Refer to [Airspace Classification](#) to get more details). As each country has its own rules, make sure to configure the parameters to comply with these rules too, before using the PHANTOM 2 VISION.
- (2) Users in Mainland China can refer to [民用航空使用空域办法](#).

## 11.6.1 Max Height & Radius Limits

The Max Height & Radius restricts the flying height and distance. Configuration can be done in the PHANTOM 2 VISION Assistant. Once complete, your aircraft will fly in a restricted cylinder.

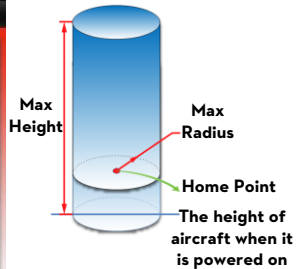

Ready to Fly ● ● ● ● ●		
	Limits	Rear LED flight indicator
Max Height	The flight height is restricted to fly under the max height.	None.
Max Radius	The flight distance is restricted to fly within the max radius.	Rapid red flashings ●●●●● when close to the Max radius limit.

Ready to Fly(non-GPS) ● ● ● ● ●		
	Flight Limits	Rear LED flight indicator
Max Height	The flight height is restricted to fly under the minor height between the Max height and 120m.	None.
Max Radius	Not limited and no LED indicators.	

-  (1) If the aircraft flies out of the limits, you can still control your aircraft except to fly it further away.

(2) If the aircraft is flying out of the max radius in Ready to Fly (non-GPS) status, it will fly back within the limits range automatically if 6 or more GPS satellites have been found.

## 11.6.2 Flight Limits of Special Areas

Restricted areas include airports worldwide. All restricted areas are listed on the DJI official website at <http://www.dji.com/fly-safe/category-mc>. Restricted areas are divided into category A and category B. Category A areas cover major international airport such as LAX and Heathrow, while category B areas includes smaller airports.

### Category A Safety Zone

- The category A “safety zone” is comprised of a small “no-fly zone” and a range of “restricted-altitude zones”. Flight is prevented in the “no-fly zone” but can continue with height restrictions in the restricted-altitude zone.
- 1.5 miles (2.4 km) around a designated safety zone is a no-fly zone, inside which takeoff is prevented.
- 1.5 miles (2.4 km) to 5 miles (8 km) around restricted areas are altitude restricted, with maximum altitude going from 35 feet (10.5 m) at 1.5 miles (2.4 km) to 400 feet (120 m) at 5 miles (8 km).
- A “warning zone” has been set around the safety zone. When you fly within 320 feet (100m) of the safety zone, a warning message will appear on the DJI Vision app.

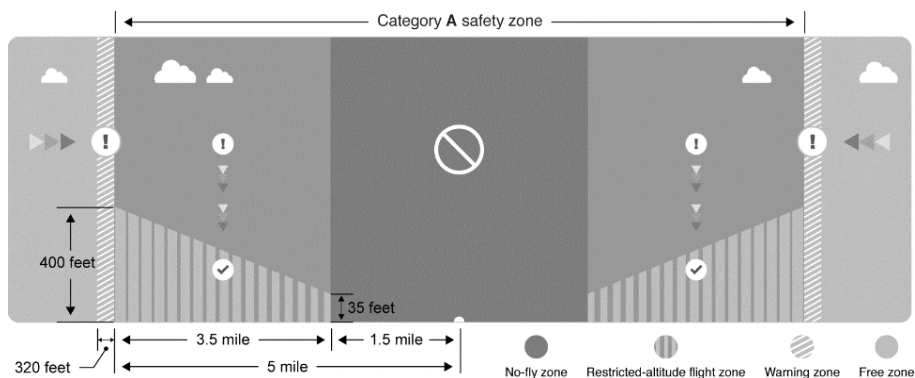



### Category A

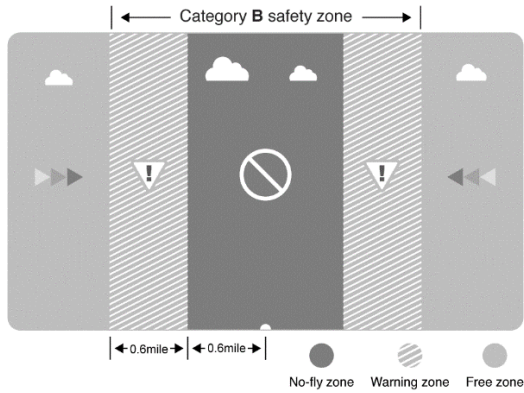

### Category B Safety Zone

- Category B “safety zone” is comprised of a “no-fly zone” and a “warning zone”.
- 0.6 miles (1 km) around the safety zone is a designated “no-fly zone”.
- A “warning zone” has been set around the safety zone. When you fly within 0.6 miles (1km) of this zone, a warning will appear on the DJI Vision app.



### Category B

Ready to Fly mode ●●●●●			
Zone	Restriction	DJI VISION App Notification	Rear LED Flight Indicator
No-fly Zone 	Motors will not start.	Warning: You are in a No-fly zone. Take off prohibited.	
	If the Phantom enters the restricted area in Ready to Fly (non-GPS) mode but Ready to Fly mode activates, the Phantom will automatically descend to land then stop its motors after landing.	Warning: You are in a No-fly zone, automatic landing has begun. (If you are within 1.5 mile radius)	
Restricted-altitude flight zone 	If the Phantom enters a restricted area in Ready to Fly (non-GPS) mode and Ready to Fly mode activates, it will descend to a safe altitude and hover 15 feet below the safe altitude.	Warning: You are in a restricted zone. Descending to safe altitude. (If you are between the range of 1.5 mile and 5 mile radius)	

		Warning: You are in a restricted zone. Max flight height restricted to between 10.5m and 120m. Fly Cautiously.	
Warning zone 	No flight restriction applies, but there will be warning message.	Warning: You are approaching a restricted zone, Fly Cautiously.	
Free zone 	No restrictions.	None.	None.

**Semi-automatic descent:** All stick commands are available except the throttle stick command during the descent and landing process. Motors will stop automatically after landing. Users must toggle the S1 switch to regain control. This is the same as regaining control during Failsafe. Please refer to [Regaining Control During Failsafe Procedure \(Page 34\)](#).

(1) When flying in the safety zone, LED flight indicators will blink red  quickly and continue for 3 seconds, then switch to indicate current flying status and continue for 5 seconds at which point it will switch back to red blinking.

(2) For safety reasons, please do not fly close to airports, highways, railway stations, railway lines, city centers and other special areas. Try to ensure the aircraft is visible.

### 11.6.3 Conditions of Flight Limits

In different working modes and flight modes, flight limits will differ according to number of GPS satellites found. The following table demonstrates all the cases (√: available; x: unavailable).

All flights are restricted by height, distance and special areas simultaneously. The Failsafe and Ground Station operations are not restricted to flight limits, but if Ground Station function is used, the flight will be restricted the special area limits built in to Ground Station. Refer to the Ground Station manual for details.

Phantom mode			
Flight Status	Limits of Special Area	Max Height	Max Radius
Ready to Fly	√	√	√
Ready to Fly (non-GPS)	x	√	x

Naza-M mode				
Control Mode	number of GPS found	Limits of Special Area	Max Height	Max Radius
GPS	$\geq 6$	√	√	√
	$< 6$	x	√	x
ATTI.	$\geq 6$	√	√	x
	$< 6$	x	√	x
Manual	$\geq 6$	x	x	x
	$< 6$	x	x	x

#### 11.6.4 Disclaimer

Please ensure that you are up to date with international and domestic airspace rules and regulations before using this product. By using this product, you hereby agree to this disclaimer and signify that you have read this fully. You agree that you are responsible for your own conduct and content while using this product, and for any direct or indirect consequences caused by not following this manual, violating or disregarding other applicable local laws, administrative rules and social habits thereof.

# 12 Using DJI VISION App

The DJI VISION App controls the PHANTOM 2 VISION camera including capture and recording, settings, pitch angle adjustments, and displays essential status including flight parameters and battery life.

## 12.1 DJI VISION App Main Menu

After login you will come to the main page. This shows the current Wi-Fi connection and four app function icons.



Icons	Description	
	<b>Camera</b>	Tap to enter camera preview
	<b>Album</b>	Tap to enter Album
	<b>News</b>	Tap to enter DJI news
	<b>Settings</b>	Tap to enter App settings
	<b>Checklist</b>	Tap to enter preflight checklist.

(1) Connect your mobile device to the PHANTOM 2 VISION Wi-Fi network to use the camera and onboard album.



(2) Connect your mobile device to the internet (mobile or Wi-Fi) to share photos, videos and read DJI news.

(3) If you receive a phone call during flight, the live camera preview screen may be interrupted. It's recommended to ignore the call and pay full attention to your flight.

## 12.2 Camera Page

### Basic Use

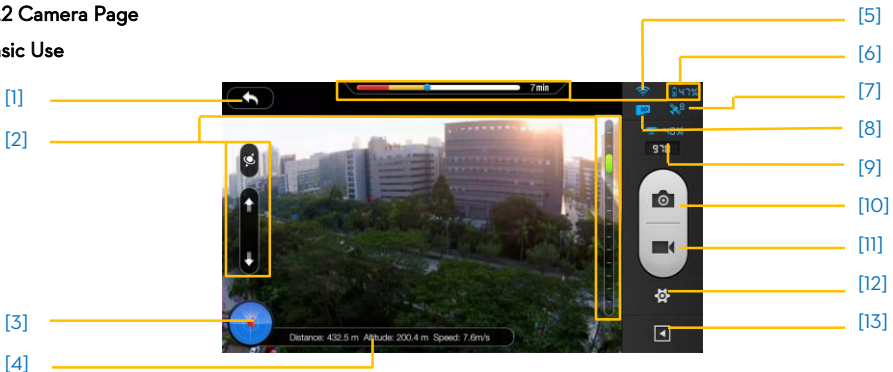



## [1] Return

 - Return to the preview page

## [2] Camera Tilt Control

 - Tilt Control Mode. Tap and hold to enter the Accelerometer Sensor Mode. Release to return to normal mode.



### Normal Mode

Tap up arrow () to pitch camera upwards and down arrow () to pitch downwards. Green slider indicates current camera pitch.



### Accelerometer Sensor Mode

Tap and Hold to switch on Accelerometer Sensor Mode to control camera pitch and rotation by moving your mobile device.

Tilt device forward to pitch camera downward and backward to pitch upward. Lean it left to rotate left () and right to rotate right ()

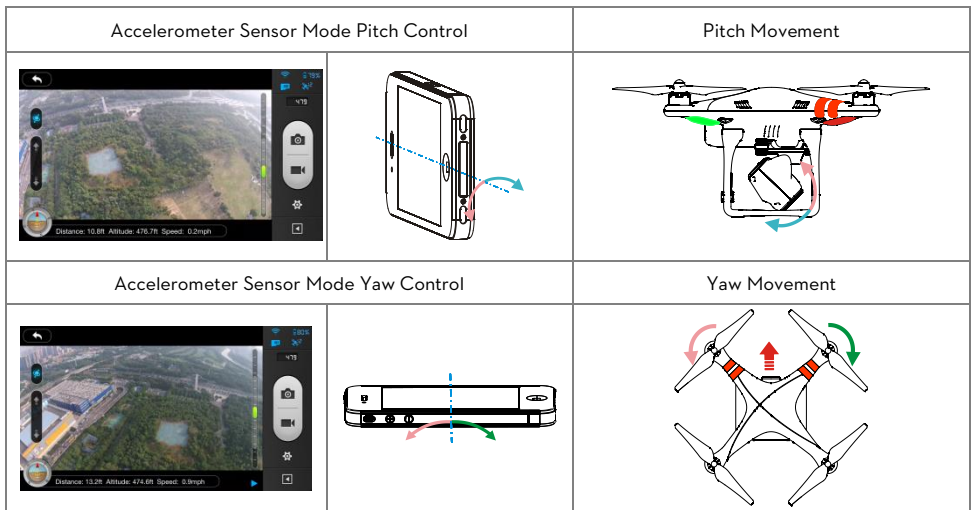

In Accelerometer Sensor Mode, the pitch angle indicator will show a grey area. When the green pitch indicator is inside the grey area, the camera will move according to pitch gestures. When the indicator reaches the boundary of the grey area, pitch gestures will control the camera's pitch speed at a constant rate.

### [3] Flight Attitude and Radar Function

Flight attitude is indicated by the flight attitude icon.

- (1) The red arrow shows which direction the PHANTOM 2 VISION is facing.
- (2) Light blue and dark blue areas indicate pitch.
- (3) Pitching of the boundary between light blue and dark blue area shows roll angle.
- (4) An orange circle around the radar indicates that the dynamic home point is not available.

A green circle around the radar indicates that the dynamic home point is available and a new home point has been set.



Tap the flight attitude icon to turn on the radar function. Home is located in the center of the radar and the red icon indicates the PHANTOM 2 VISION's current heading, direction, and approximate distance from home. The current longitude and latitude of the aircraft is displayed on the bottom of the radar. Tap the flight attitude icon again to disable the radar.



Home Point

Longitude & Latitude



PHANTOM 2 VISION

Mobile Device Location

Distance

- (1) By default, the center of the radar indicates the home point that has been recorded by the PHANTOM 2 VISION. Tap the center of the radar to switch the center to your mobile device's current location.



- (2) If your mobile device contains a compass, the top portion of the Radar is the direction you are pointing. If not, the radar will be oriented due north.

### [4] Flight Parameters

Tap to set return home (RTH) altitude.

Distance: Horizontal distance from home point.

Altitude: Vertical distance from home point.

Speed: Horizontal flying speed.

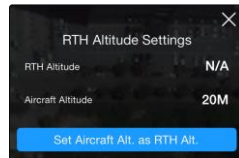



Distance will appear as N/A if the PHANTOM 2 VISION is not Ready to Fly.

### [5] Wi-Fi Signal Intensity

Indicates camera is connected to your mobile device and Wi-Fi is working normally.

The connection between the camera and mobile device may fail if Wi-Fi signal strength is low. Refer to the PHANTOM 2 VISION CONNECTION BROKEN on the camera page.

#### [6] Aircraft Battery Level

- (1) When available power is more than 30%, the battery icon is blue (e.g. ). This battery level is appropriate for flight.
- (2) When below 30%, the battery icon will turn red (e.g. ) and the LED flight indicator will slowly blink red. This battery level is low for flight. It is recommended that you fly your PHANTOM 2 VISION home and land it as soon as possible.
- (3) After available power drops below 15% (e.g. ), there is no longer enough power for flight. The LED flight indicator will begin to flash red rapidly and the PHANTOM 2 VISION will begin an automatic descent and land.



The available power thresholds mentioned above can be adjusted in the PHANTOM 2 VISION Assistant.

#### [7] Aircraft GPS Status

Displays GPS status and the number of available satellites. The icon is highlighted when more than 6 satellites are found, enabling Ready to Fly mode.

#### [8] Micro-SD Card Status

Displays Micro-SD Card Status. The icon is highlighted when a valid Micro-SD card is inserted. If there is no Micro-SD card present, it is grayed out.

#### [9] Remaining Shots

Displays estimated shots remaining, based on the current Photo Size setting of camera and the storage capacity of the Micro-SD card. This shows '0' if:

- (1) Micro-SD card is not inserted.
- (2) Micro-SD card is full.
- (3) Micro-SD card is damaged.
- (4) Connection between the DJI VISION App and camera is broken.

#### [10] Shutter Button

Tap to take photos.

Single capture: press once for a single capture.

Continuous capture: press once for 3 or 5 captures.

Timed capture: press once to begin a timed capture, press again to stop.



- (1) Shutter button is disabled during video recording.
- (2) Capture modes can be reconfigured in camera settings; refer to the [Camera Settings \(Page 46\)](#).

## [1] Record Button

Start and Stop video recording. Tap once to start recording. A red dot will blink to indicate recording is in progress and a time elapsed counter will appear in the top right corner of the preview screen. Press again to stop recording.

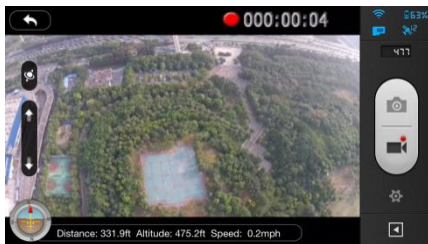

## [12] Camera Settings

Tap to open the camera settings menu, refer to [Camera Settings \(Page 46\)](#).







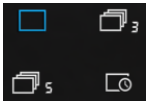

## [13] Hide or Show Flight Parameters.

Tap to hide the flight parameters. Tap again to show.





## Camera Settings



## [1] Capture Mode

	 3 captures.
	 5 captures.
	 Timed capture. Also selectable:
	a) Intervals between two shots (3-60 s) b) Number of shots (2-254, or infinite shots until Micro-SD card is filled)
Capture Button will change according to the selected capture mode. (     )	



## [2] Photo Size

	 Large: 4384 x 3288, 4:3, 14.4MP
	 Medium: 4384 x 2922, 3:2, 12.8MP
	 Small: 4384 x 2466, 16:9, 10.8MP

## [3] Video Resolution

	1920 x 1080 60i, 16:9
	1920 x 1080 30p, 16:9
	1920 x 1080 25p, 16:9
	1280 x 960 30p, 4:3
	1280 x 960 25p, 4:3
	1280 x 720 60p, 16:9
	1280 x 720 30p, 16:9
	640 x 480 30p, 4:3 (VGA)
<p>Three Field of View (FOV) options are supported when shooting in 1920x1080 60i, 1920x1080 30p and 1920x1080 25p: Wide (120°), Medium (110°) and Narrow (85°).</p>	

## [4] Photo Format

	 JPEG							
	 RAW							
	<p>The PHANTOM 2 VISION camera shoots in JPEG and RAW file formats simultaneously when this option is selected. See the following table for detailed specifications.</p> <table border="1"> <tr> <td>JPEG photo size</td> <td>4384 X 3288</td> <td>4384 X 2922</td> <td>4384 X 2466</td> </tr> <tr> <td>RAW photo size</td> <td>4384 X 3288</td> <td>4384 X 2920</td> <td>4384 X 2464</td> </tr> </table>	JPEG photo size	4384 X 3288	4384 X 2922	4384 X 2466	RAW photo size	4384 X 3288	4384 X 2920
JPEG photo size	4384 X 3288	4384 X 2922	4384 X 2466					
RAW photo size	4384 X 3288	4384 X 2920	4384 X 2464					
<p>RAW is not supported in continuous capture mode or timed capture mode. JPEG photos will be created automatically.</p> <p>RAW format support will be coming soon with DJI Conversion Software to convert PHANTOM 2 VISION's Camera RAW files to Adobe DNG.</p>								

## [5] Selectable ISO

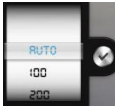
	AUTO
	100
	200
	400

### [6] White Balance

	AWB (auto)
	Sunny
	Cloudy
	Indoor

### [7] Exposure Metering

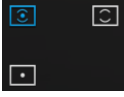
	Center
	Average
	Spot

### [8] Exposure Compensation

	-2.0 ( EV )	2.0 ( EV )
	-1.7 ( EV )	1.7 ( EV )
	-1.3 ( EV )	1.3 ( EV )
	-1.0 ( EV )	1.0 ( EV )
	-0.7 ( EV )	0.7 ( EV )
	-0.3 ( EV )	0.3 ( EV )
	0 ( EV )	

### [9] Sharpness

	Standard
	Hard
	Soft

### [10] Anti-flicker

	Auto
	50Hz
	60Hz

### [11] Restore Default Settings

Restores all camera default settings. Camera reboot is needed to allow restoration to take effect.

## [12] Format SD Card

Format the Micro-SD card. All data stored in the Micro-SD card will be lost after formatting. Remember to backup before formatting.

## 12.3 Album Page

### Camera SD CARD Album

Browse thumbnails of photos and videos stored on the Micro-SD card. Tap to view photo or watch video.

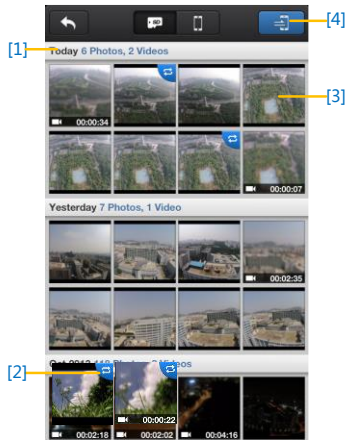



[1] Photos and Videos are listed and grouped by date.

[2] All photos and videos that have already been synced to your mobile device are identified with the  icon.

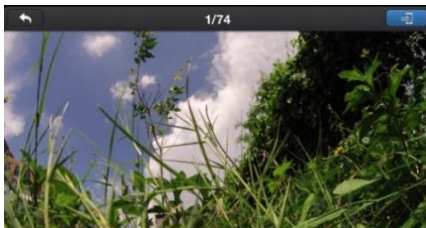
[3] Tap any thumbnail for single view mode. Tap a Photo thumbnail that hasn't been synchronized to the mobile device to view the photo. Swipe left or right to view the previous or next photo item. Tap on a video thumbnail to play it and view the video's length. A progress bar will also appear at the bottom of the screen. Tap  to enter single synchronization mode to synchronize a single photo or video, or to synchronize and play a video at the same time.



[4] Tap the button  to enter multiple synchronization mode (as shown in the following diagram). Tap thumbnails to select photos or videos to synchronize to your mobile device (The thumbnails identified by the check mark

are successfully selected.). Or you can select one or more groups to be synchronized by checking the box before the group, and then tap  to start synchronizing. During the synchronization process, users can tap  to cancel the synchronization. Photos and videos that have been synchronized to the mobile device will remain.

 Some mobile devices may fail to support synchronization of 1080i60 video files.

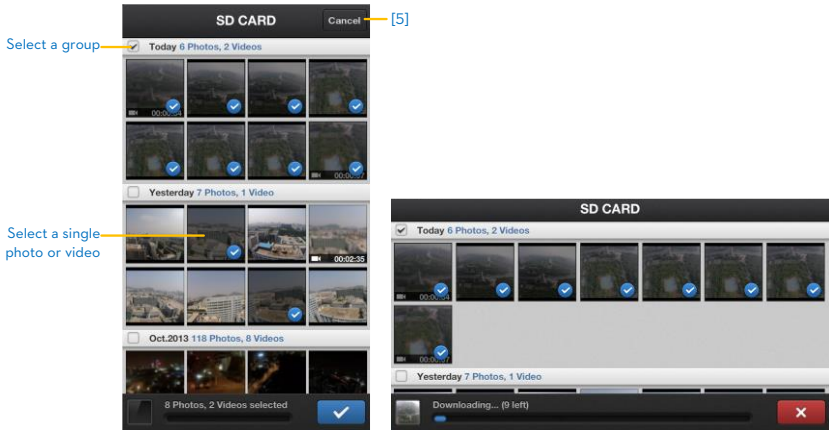

[5] Tap “Cancel” or “Finished” to exit the multiple synchronization mode and return to the SD CARD page.

### Mobile Device Album

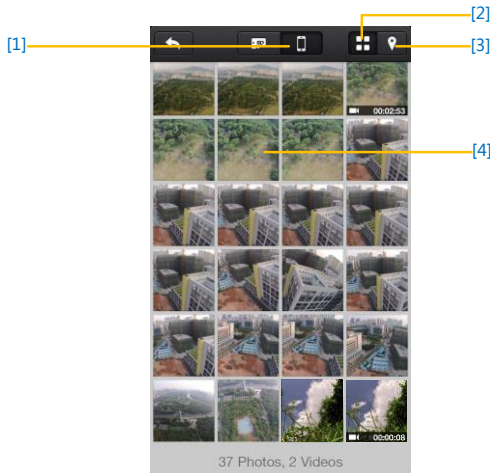

[1] You can browse all photos and videos in the album which have been synchronized to the mobile device, view a selected photo or play a selected video.

[2] Photos and videos are listed in thumbnail style and sorted by capture time.

[3] Pictures and videos are sorted by captured/recorded Geo-tagged locations.

 Access to the Internet is required to load a map.



Geo-tagged locations

[4] Tap any thumbnail for single view; you can slide left or right to view the previous or next photo. Tap a video thumbnail to play a single video.

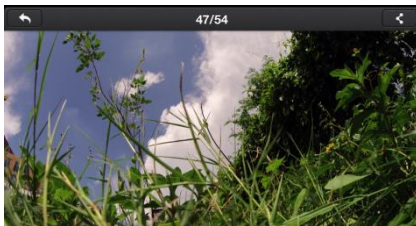

[5]

[5] Tap to share your photos and videos to social network sites.

 Access to the Internet is required to share your photos and videos.



**SHARING**  
Share Your Glorious Moment with Your Friends

## 12.4 News Page

View the latest DJI news. (Internet access is required.)

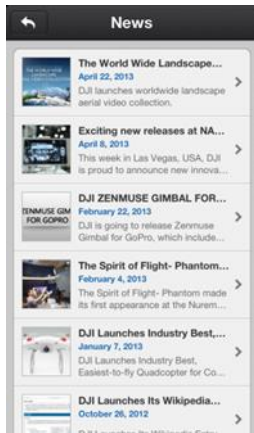

News List



News Details

## 12.5 Settings Page

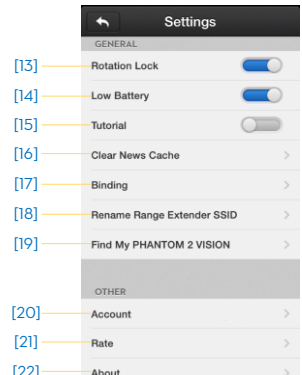
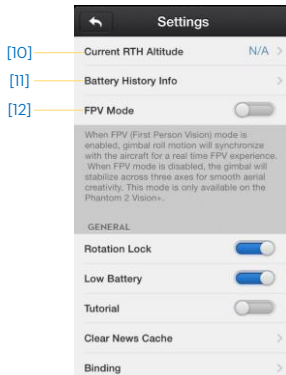
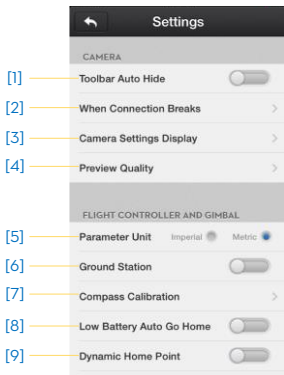

### [1] Toolbar Auto Hide

Slide the switch from left to right to enable this function. The toolbar will auto hide on the camera page.



Toolbar Auto Hide Disabled

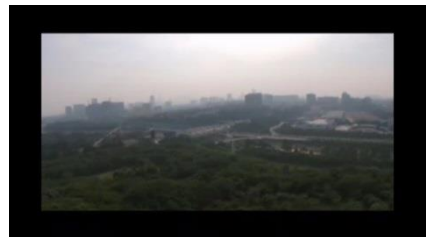

Toolbar Auto Hide Enabled

## [2] When Connection Breaks



### Stop Recording:

Enabled: Stop recording when the Wi-Fi connection between the mobile device and the camera breaks while the camera is recording.

Disabled: Keep recording when the Wi-Fi connection between the mobile device and the camera breaks while the camera is recording.

**Start Recording / Start Continuous Capture / Stay in Idle:** Select the state the camera will enter in the event of a Wi-Fi Connection break between the mobile device and the camera. Use this function to ensure you continue to capture the scenes you don't want to miss during a flight.

## [3] Camera Settings Display

For iOS users, an enabled item will display in the camera settings toolbar, while a disabled item will be hidden.

For Android users, there is no this item.

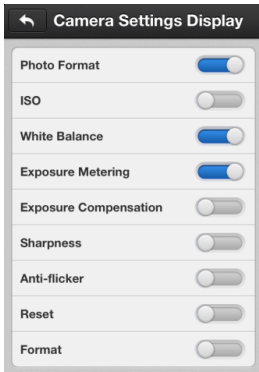

## [4] Preview Quality

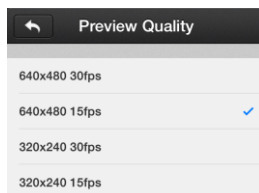

High: 640×480@30fps

Medium: 640×480@15fps

Medium: 320×240@30fps

Low: 320×240@15fps (Recommended when there is a lot of interference.)

#### **[5] Parameter Unit**

Select imperial or metric units of measurement.

#### **[6] Ground Station**

Slide to the right to enable ground station feature.

#### **[7] Compass Calibration**

Tap to calibrate the compass. Do not calibrate the compass during flight.

#### **[8] Low Battery Auto Go Home**

Enable or disable auto go home feature when battery is low.

#### **[9] Dynamic Home Point**

When activated, the Home point will be reset to your current position at specific time intervals. The aircraft will return to the latest Home point as required.

#### **[10] Current RTH Altitude**

Default RTH altitude set to 20m. Raising the RTH altitude above 120m is not recommended.

#### **[11] Battery History Info**

Show the battery history warning records.

#### **[12] FPV Mode**

Switched on, the gimbal will work in FPV mode.

Switched off, the gimbal will work in Stabilize mode.

#### **[13] Rotation Lock**

The user interface of the DJI VISION App will rotate if rotation lock is enabled (for iOS device only).

#### **[14] Low Battery Warning**

If enabled, an alarm will sound when the battery level is too low. Be sure sound is enabled on the mobile device and try to adjust the volume to the highest level.

#### **[15] Tutorial**

Hints and Tips

#### **[16] Clear News Cache**

Tap to flush news cache.

#### **[17] Binding**

In the event the camera and range extender bind is lost or one of them requires repair or replacement, camera and range extender binding should be performed via the DJI VISION App. Refer to the [How to Bind the Camera & Range Extender \(Page 15\)](#) for details.

## [18] Rename SSID of Range Extender

Tap to rename the SSID of the Range Extender. Follow the instructions on the App GUI.

## [19] Find My PHANTOM 2 VISION

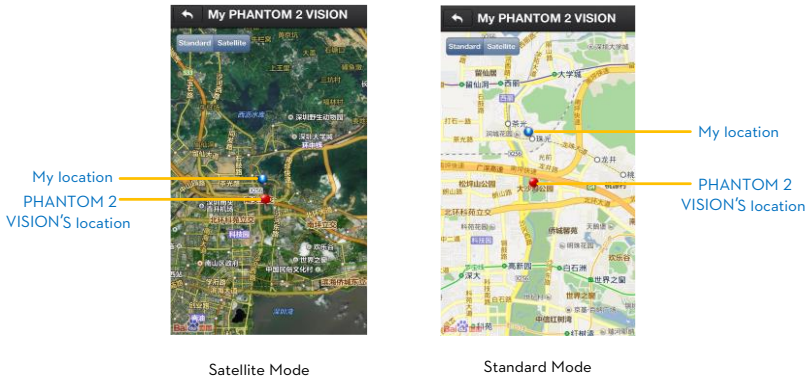

## [20] Account

Tap to see user account information.

## [21] Rate

For iOS users, tap to rate the DJI VISION App. Internet access is required.

For Android users, there is no this item.

## [22] About

Tap to see the current version of the DJI VISION App and contact information.

## 12.6 Ground Station

The DJI Vision app features an integrated ground station function. Using it you can create flight missions by placing waypoints and setting waypoint altitude and overall speed. When flight plan has been created, simply tap “GO” and your aircraft will execute the flight mission automatically. You may also abort the flight mission and return home by tapping “GoHome” button.



Upgrade Phantom firmware to the latest version to enable ground station feature. Refer to the [Firmware Upgrade of the PHANTOM 2 VISION \(Page 63\)](#) for more information about how to upgrade the firmware.

## 12.6.1 Ground Station GUI

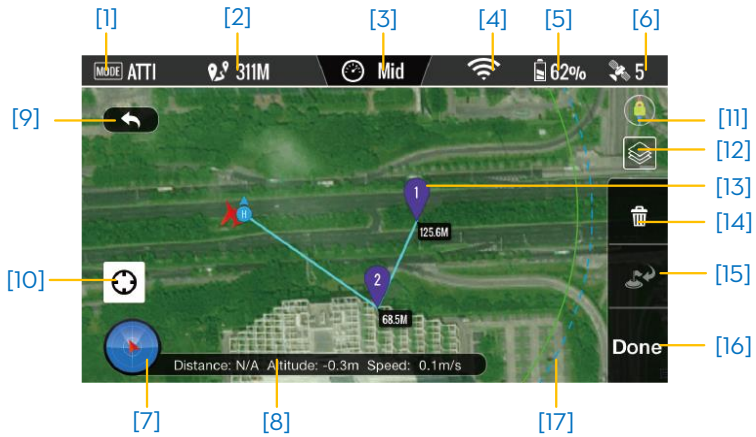

### [1] MODE

Modes include

Hover : Hovering

Waypoint : Mission in progress

GoHome : Returning to home point

Take off : Taking off

Landing : Landing

GPS : GPS flight

Atti. : Atti. flight

Manual : Manual flight

### [2] Approximated Flight Mission Distance

Planned mission distance. To achieve optimum battery performance, max mission distance is restricted to 5km (3miles).

### [3] Speed

For flight safety concern, only three gears of flight speed are available. Choose from Fast (8m/s), Mid(4m/s) and Slow (2m/s) for flight speeds. Estimated 10 minutes flight is achievable when the aircraft travels in "Fast" gear.

### [4] Wi-Fi Signal Strength

Wi-Fi signal strength display. Refer to the [Basic Use \[5\] \(Page 44\)](#) in Camera Page for details

**[5] Battery Level**

Battery level display. Refer to the [Basic Use \[6\] \(Page 45\)](#) in Camera Page for details

**[6] GPS**

Number of satellites connected. Refer to the [Basic Use \[7\] \(Page 45\)](#) in Camera Page for details

**[7] Flight Attitude and Radar**

Attitude and Radar display. Refer to the [Basic Use \[3\] \(Page 44\)](#) in Camera Page for details

**[8] Flight Parameters**

Flight information display. Refer to the [Basic Use \[4\] \(Page 44\)](#) in Camera Page for details

**[9] Back**

Return to camera GUI.

**[10] Home Point Locator**

Locate your Home point.

**[11] Orientation Lock**

Unlock to sync map orientation with aircraft movement

**[12] Map View**

Select map view from standard, hybrid or satellite.

**[13] Waypoint**

Tap each waypoint to set altitude

**[14] Delete**

Delete current waypoint.

**[15] Go Home**

Abort mission, return home and land

**[16] Done**

Hit "Done" then tap "GO" to begin mission.

**[17] Flight Area**

The aircraft can fly in this area and return to the home point with the current battery level. This area is dependent on the current state of the aircraft and will be refreshed at specific time intervals.

## 12.6.2 Using Ground Station

### Step 1 Launching Ground Station :

Enable ground station feature from DJI Vision app Settings and a disclaimer for ground station prompts. Read the disclaimer thoroughly before starting to use ground station.

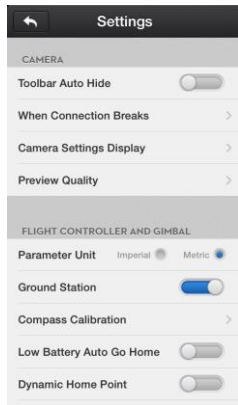

Ensure your mobile device has access to the Internet. Due to the map data required, Wi-Fi connection is recommended. Internet access is required to cache the ground station map, if Wi-Fi is unavailable, mobile data service is required. Open the DJI Vision app camera GUI and swipe left to launch ground station. DJI Vision app cannot connect to your aircraft while it is accessing the Internet. Hence, you may prompt with the warning message such as “Connection to Phantom Failed”. This message will not appear when your aircraft is re-connected to DJI Vision app. Map data of your current location will load. You can then drag the map to cache nearby areas for future use.

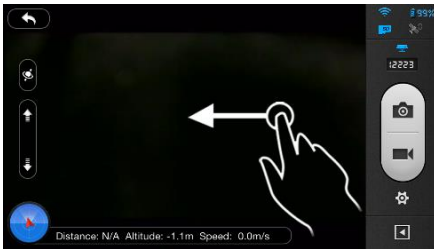

### Step 2 Setting a Waypoint :

Disconnect from the Internet and connect the DJI Vision app to your aircraft. Check that remote control S1 switch is in  position (position-1) and the upper left corner in ground station display **MODE: GPS** and wait for the aircraft to enter “Ready-to-Fly” mode (LED indicator blinking green) before swiping left into ground station. Tap on the map to place a waypoint. You can place up to 16 waypoints including the Home point. Waypoints cannot be placed beyond 500m from the Home point or inside No Waypoint Areas.



- (1) A red circle on the map, as shown in the screenshot below, indicates a restricted, No Waypoint area. Waypoints cannot be placed in this area. For more information, refer to the [Flight Limits of Special Areas \(Page 38\)](#).
- (2) To achieve the optimal video transmission quality, the aircraft is set to operate within a 500m-radius area from Home point.



Tap on a waypoint to open a waypoint properties window. Modify longitude and latitude value from the input box. Slide the white dot right to adjust waypoint altitude. The default altitude is set to 98 feet (20 m) and can be adjusted from 0 to 650 feet (200 m). Tap “OK” to save waypoint settings. To delete current waypoint, tap .

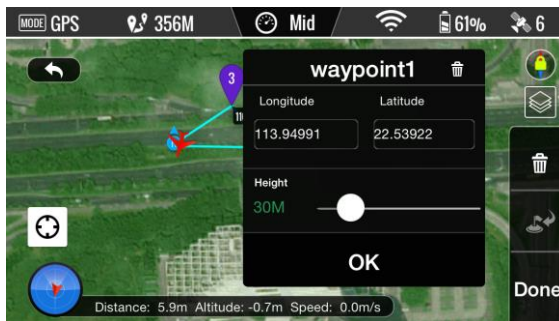

### Step 3 Preview a Mission :

Tap “Done” to preview the mission when all waypoints are set. A prompt similar to the one below will appear.



This prompt lists all waypoints and their altitudes. The aircraft will fly to each waypoint listed. If there is a difference in altitude between waypoints, the aircraft will adjust its altitude as it flies between points. When ready, tap “GO” to begin mission.

Aircraft reacts differently to the “GO” command :



- (1) If aircraft is on the ground, the aircraft takes off automatically and ascend 16 feet (5m) then fly to the first waypoint.
- (2) If aircraft is in the air, the aircraft flies to the first waypoint.

#### Step 4 Executing Flight Mission

The aircraft flies to each waypoint in numerical order. As it flies, swipe back into the DJI Vision app camera GUI to control camera tilt and capture photos or video. Tap **||** to pause the mission during the flight, and aircraft will then start hovering. Tap **▶** to resume mission. If you wish to regain control of the aircraft, toggle the S1 switch on remote control from (Position-1) to either (Position-2) or (Position-3) to discontinue the current mission.

#### Step 5 Landing

When all waypoints have been visited, the aircraft will return to its Home point and hover. Regain control of the aircraft and land it manually. You may also tap button to initiate “Go Home” procedure. Aircraft will abort current mission, return to Home point and auto land.



# 13 Assistant Installation and Configuration

## 13.1 Installing Driver and PHANTOM 2 VISION Assistant

### Installing and running on Windows

1. Download driver installer and Assistant installer in **EXE** format from the download page of PHANTOM 2 VISION on the DJI website.
2. Connect the PHANTOM 2 VISION to a PC via a Micro-USB cable.
3. Run the driver installer and follow the prompts to finish installation.
4. Next, run the Assistant installer and follow the prompts to finish installation.
5. Double click the PHANTOM 2 VISION icon on your Windows desktop to launch the software.



The installer in EXE format only supports Windows operating systems (Win XP, Win7, Win8 (32 or 64 bit)).

### Installing and running on Mac OS X

1. Download the Assistant installer in **DMG** format from the download page of PHANTOM 2 VISION on the DJI website.
2. Run the installer and follow the prompts to finish installation.



3. **When launching for the first time** if use Launchpad to run the PHANTOM 2 VISION Assistant, Launchpad won't allow access because the software has not been reviewed by Mac App Store.



4. Locate the PHANTOM 2 VISION icon in the Finder, press the Control key and then click the icon (or right-click the icon using a mouse). Choose Open from the shortcut menu, click Open in the prompt dialog box and then software will launch.
5. After the first successful launch, direct launching of the software can be achieved by double-clicking the

PHANTOM 2 VISION icon in the Finder or using Launchpad.





Installer in DMG format supports only Mac OS X 10.6(Lion) or above.



Usage of PHANTOM 2 VISION Assistant on Mac OS X and Windows are exactly the same. The Assistant pages appear in other places of this manual are on the Windows for example.

### 13.2 Using the PHANTOM 2 VISION Assistant on a PC

1. Start up the PC, power on the PHANTOM 2 VISION, then connect the PHANTOM 2 VISION to the PC with a Micro-USB cable. DO NOT disconnect until configuration is finished.
2. Run the PHANTOM 2 VISION Assistant and wait for the PHANTOM 2 VISION to connect to the Assistant. Observe the indicators  on the bottom of the screen. When connected successfully, the connection indicator is  and communication indicator is blinking .
3. Choose [Basic] or [Advanced] configuration pages.
4. View and check the current configuration in the [View] page.

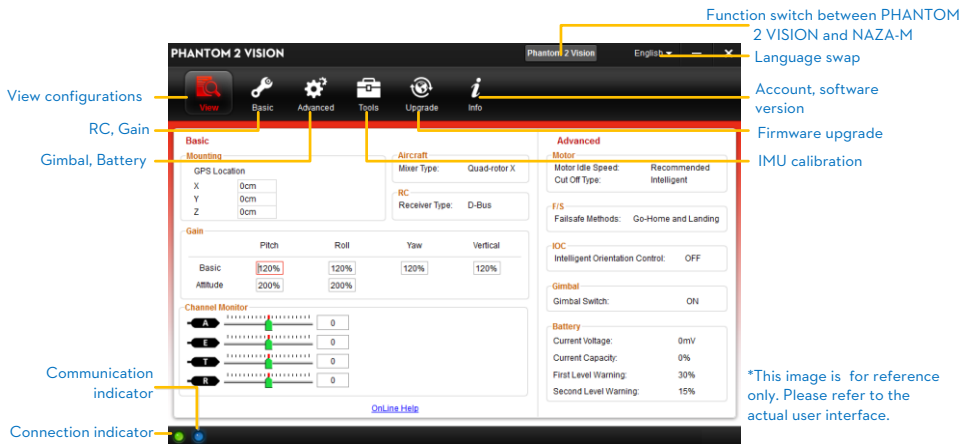

(1) Users should not enable the Naza-M function before finishing the “Advanced Flight Maneuvers” procedure, in accordance with the “Phantom Pilot Training Guide”. If the Naza-M function is enabled, users can switch the control mode to either the ATTI. Mode, GPS Mode or Manual Mode, and access the advanced settings (e.g. IOC). In addition, the LED located on the rear frame arms will display the flight status according to the Naza-M’s indicator, instead of the Phantom 2 Vision’s indicator. Do not enable the Naza-M function unless you are an experienced user or guided by a professional.

(2) You can change to the Phantom 2 Vision function by tapping the same button if the Naza-M function is enabled. This operation will disable the Naza-M function and enable the Phantom 2 Vision function. All parameters will be returned to factory settings.

### 13.3 Firmware Upgrade of the PHANTOM 2 VISION

Please refer to the PHANTOM 2 VISION Assistant to install driver and PHANTOM RC Assistant, and then follow the procedures below to upgrade the software and firmware; otherwise the PHANTOM 2 VISION might not work properly.

1. An internet connection is required to upgrade the PHANTOM 2 VISION’s firmware.
2. Click the [Upgrade] icon to check the current firmware version and whether the installed firmware is the latest version. If not, click the relative links to upgrade.
3. Be sure to wait until the Assistant shows “finished”. Click OK and power cycle the PHANTOM 2 VISION after 5 seconds. Once completed, the firmware is up to date.

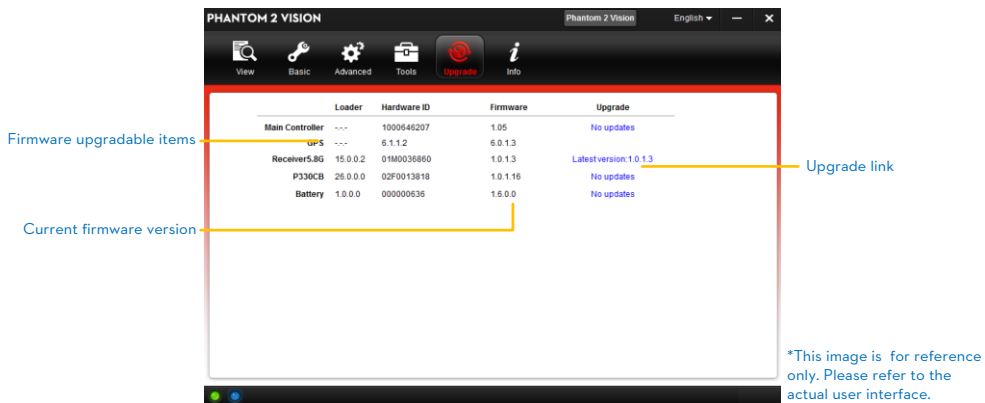



- (1) DO NOT power off until the upgrade is finished.
-  (2) If the firmware upgrade failed, the main controller will enter a waiting for firmware upgrade status automatically. If this happens, repeat the above procedures.

- Firmware upgradable items:
- (1) Main Controller
  - (2) GPS
  - (3) 5.8G Receiver
  - (4) P330CB (Main Board)
  - (5) Battery

### 13.4 PHANTOM RC Assistant Description

Please follow the procedures to finish the configuration of the remote control.

1. Turn off the remote control and find the Micro-USB port on the back of it. (If there is no one, users should open the rear cover to find the Micro-USB port on the board inner the remote control.)
2. Start up the PC, power on the remote control, and then Connect the remote control to the PC with a Micro-USB cable. DO NOT disconnect until the configuration is finished.
3. Run the PHANTOM RC Assistant and wait for the remote control to connect to the Assistant. Observe the indicators  on the bottom left of the screen. When connected successfully, the connection indicator is  and communication indicator is .
4. Finish configuration in the [Main] page.
5. Finish upgrade in the [Info] page if necessary.

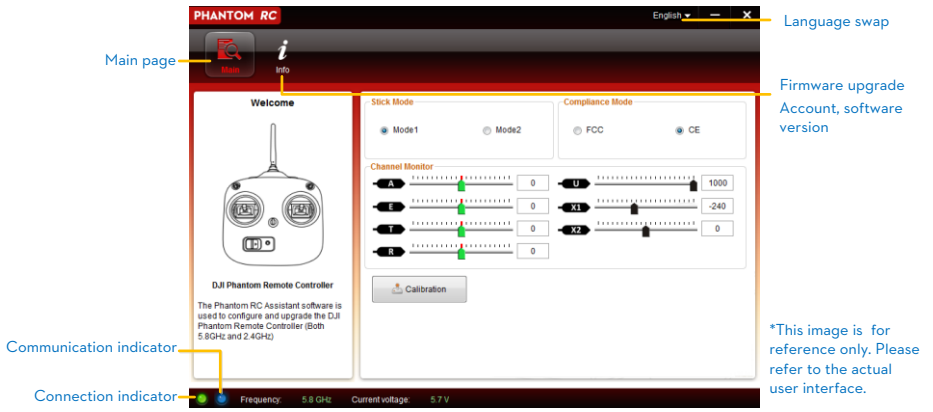

## 14 Troubleshooting (FAQ)

### 14.1 How to solve large margin(s) mid-point error?

If the Remote Control stick(s) mid-point margin of error is too big, the motors will fail to start when you execute the Combination Stick Commands (CSC) and the aircraft will not take off. Below are possible situations where the Remote Control 's stick(s) mid-point margins of error could be too big:

(1) One of the Remote Control 's stick position (except the throttle stick) is not centered when powering on the PHANTOM 2 VISION.

**Solution:** Place all Remote Control sticks at their mid-point positions and then power cycle the PHANTOM 2 VISION to re-record the mid-point. If the problem persists, this can be caused by scenario (2).

(2) The Remote Control sticks have been trimmed which leads to a large deviation of the mid-point position.

**Solution:** Use the Assistant to perform a Remote Control calibration. To do so, carry out the following procedures.

(a) Connect to the Assistant, tap Basic-> RC-> Command Sticks Calibration, and push all Remote Control sticks through their complete travel range to see if any stick cannot reach its outer most position.

(b) Power cycle the PHANTOM 2 VISION. Note that a power cycle is required.

(c) Redo the Remote Control calibration according to the Assistant.

If the above solutions do not solve your issue, please send your Remote Control to DJI Customer service for repair.

### 14.2 How to restore a video file if power is turned off during a recording session?

**Solution:** Keep or place the Micro-SD card back into the camera. Power cycle the camera and wait about 30 seconds for the video file to be restored.

### 14.3 Failure to acquire the SSID.

**Solution:** Double check whether both the camera and Range Extender are powered on and the power switch of the camera is switched to "WIFI ON".

### 14.4 What to do if PHANTOM 2 VISION is out of sight and the Wi-Fi connections is lost?

**Solution:** Turn off the Remote Control to trigger the Failsafe mode and the aircraft will start to fly back, descend, and land at the Home point automatically. Please make sure there are no obstacles within the go home route and you are familiar with the regaining control procedure.

### 14.5 Wi-Fi connection fails all the time.

**Solution:** Double check the current Wi-Fi connection status of the mobile device. The mobile device may be connecting to other Wi-Fi networks after a connection breaks with the PHANTOM 2 VISION.

### 14.6 Files fail to synchronize.

**Solution:** Video files that are too large (file sizes close to 4GB) cannot be synchronized to the mobile device. Some mobile devices also fail to support synchronization of the 1080i60 video files.

### 14.7 Albums fail to synchronize.

**Solution:** Reset the settings of your mobile device as illustrated below. Enable the Settings ->Private->Photos->DJI VISION. Otherwise the Albums will fail to synchronize with your mobile device.



### 14.8 Failure to share.

**Solution:** Please make sure the mobile device has access to the Internet.

### 14.9 Some mobile Android devices have a problem connecting to the PHANTOM 2 VISION Wi-Fi Extender.

**Solution:** Some mobile Android devices do not allow for both a Wi-Fi connection and a mobile data connection at the same time. When trying to connect to the PHANTOM 2 VISION Wi-Fi network, most devices will check whether an Internet connection has a certain Wi-Fi setting enabled, e.g. Auto network switch or Test for Internet connection. If no Internet connection is found because the PHANTOM 2 VISION creates a non-routable connection it will drop the PHANTOM 2 VISION Wi-Fi network connection and scan for the next available connection. Example: For the Samsung Note 3, carry out the following procedures to solve this issue. Tap Settings -> Wi-Fi, and then tap the "Menu" button. Select "Advanced" then uncheck the "Auto network switch". You might see a warning that indicates the Internet connection is unstable but just ignore this message.

### 14.10 Usage tips for the App used on multiple mobile devices.

During flight, if you use the App on multiple mobile devices, please turn off the App on the first mobile device, and

then turn on the App on the second one to ensure the App can work normally on the second mobile device.

#### **14.11 How to land the aircraft smoothly in a better way?**

First pull the throttle stick position down to lower than 5%, then execute the CSC command to stop the motors.

#### **14.12 Why the discharge cycle of a new battery not at zero?**

A battery aging test is performed prior to delivery which affects the discharge time of the new battery. This is why the discharge time of a new battery is not zero. The battery is okay to use.

#### **14.13 What if I accidentally exit DJI Vision App when aircraft is still operating under ground station mode?**

- If DJI Vision App is closed when aircraft is executing flight mission, aircraft continues with the remaining flight mission.
- If DJI Vision App is closed and failed to re-connect with aircraft within 1 minute, aircraft returns home point automatically.

#### **14.14 Do I need extra equipment to use ground station?**

No extra equipment is required.

#### **14.15 Can I cache map data for future use?**

Yes, user can cache map data in ground station for future use.

# 15 Appendix

## LED Flight Indicator Status

Normal status	LED Flight Indicators
Power On Self-Test	
Warming Up	
Ready to Fly	
Ready to Fly (non-GPS)	
Warning and Error	LED Flight Indicators
Remote Control Signal Lost	
Low Battery Capacity Warning	
Critical Low Battery Capacity Warning	
Not Stationary or Sensor Bias is too big	
Error*	
Compass Needs Calibration	

\*You can figure out the error by connecting the PHANTOM 2 VISION to the PHANTOM 2 VISION's Assistant.

## Specifications

Aircraft	
Supported Battery	DJI 5200mAh Li-Po Battery
PHANTOM 2 VISION Weight	1160g
Recommend payload	≤1300g
Maximum payload	1350g
Hovering Accuracy (Ready to Fly)	Vertical: 0.8m; Horizontal: 2.5m
Max Yaw Angular Velocity	200°/s
Max Tilt Angle	35°
Max Ascent / Descent Speed	Ascent: 6m/s; Descent: 2m/s
Max Flight Speed	15m/s (Not Recommended)
Wheelbase	350mm
Tilt Range of the Camera	0° - 60°
Remote Control	
Operating Frequency	5.728 GHz - 5.85 GHz
Communication Distance (open area)	CE Compliance: 300m; FCC Compliance: 500m
Receiver Sensitivity (1%PER)	-93dBm
Transmitting Power (EIRP)	CE Compliance: 25mW; FCC Compliance: 125mW
Working Current/Voltage	80mA@6V
Battery	4 AA Batteries
Camera	
Resolution	14 Megapixels
FOV	120° / 110° / 85°
Sensor Size	1/2.3"
Functions	Supports multi-capture, continuous capture and timed capture Supports HD Recording (1080p30,1080i60) Supports both RAW and JPEG photo formats
Range Extender	
Operating Frequency	2412MHz - 2462MHz
Communication Distance (open area)	300m
Transmitting Power	17dBm
Power Consumption	1.5W
DJI VISION App	
Supported Mobile Devices	Recommended: iPhone4s, iPhone5, iPhone5s, iPhone5C, iPod Touch4, iPod Touch5; Available but not recommended: iPad3, iPad4, iPad mini.

Samsung Galaxy S3, S4, Note2, Note3 or phones of similar configuration.

**System Requirement of Mobile Device**

iOS 6.0 or above; Android system 4.0 or above