



VX2428

Package Contents

- Monitor
- Power adapter
- Video cable
- Quick start guide



Front View / Rear View

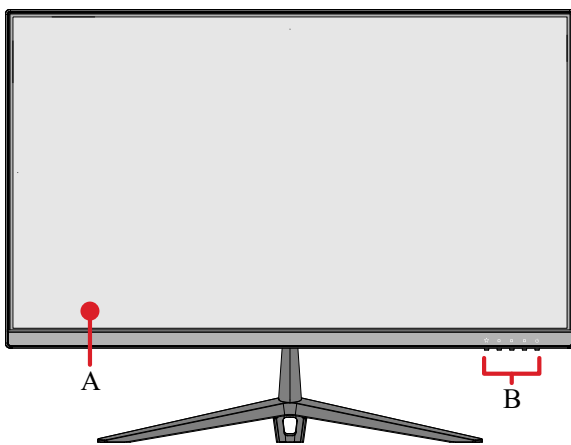

Front View

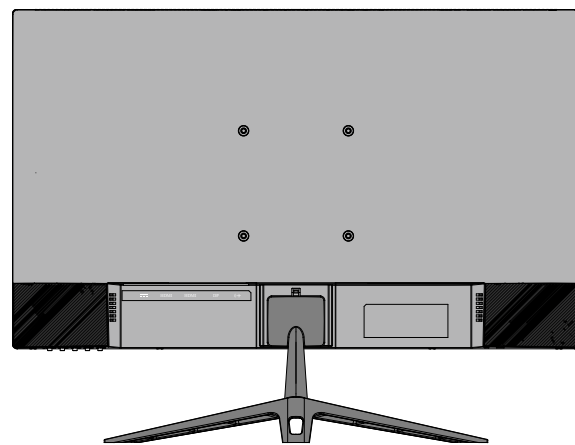

Rear View

Letter	Item
A	Display Screen
B	Control Panel Keys

I/O Ports

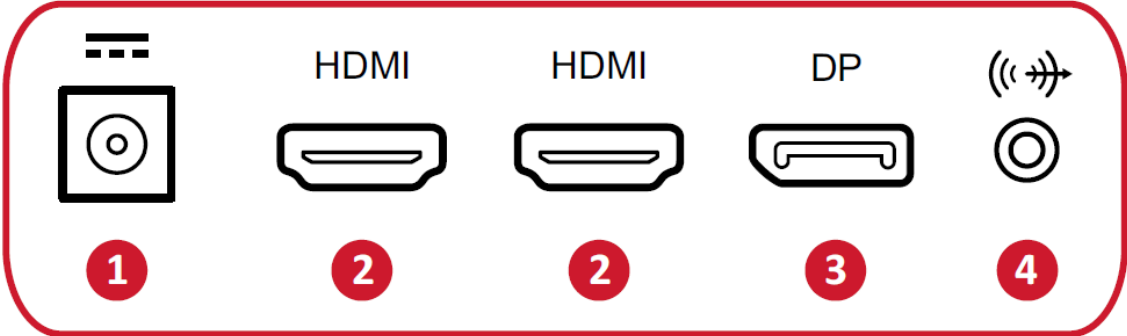

Number	Item
1	DC IN
2	HDMI
3	DisplayPort
4	Audio Out

Installing the Stand

1

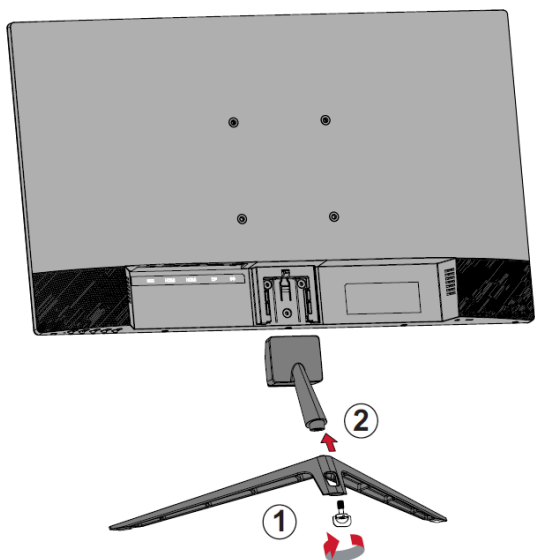

2

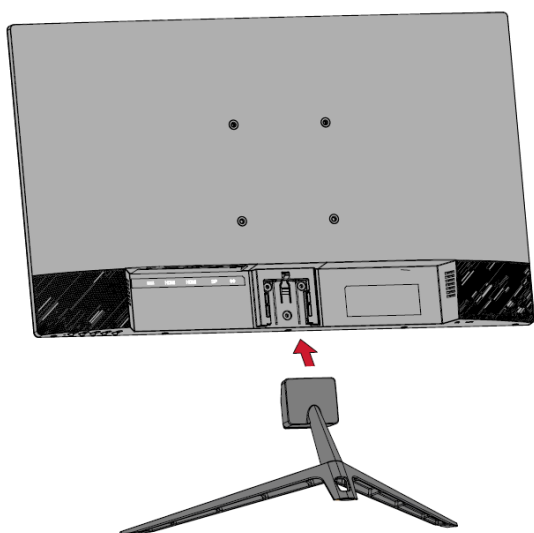

3



Always place the device on a flat, stable surface. Failure to do so may cause the device to fall and damage the device and/or result in personal injury.

Removing the Stand and Mounting the Display

Refer to the table below for the standard dimensions for mounting kits.

For use only with a UL certified wall mount kit/bracket. To obtain a wall-mounting kit or height adjustment base, contact ViewSonic® or your local dealer.

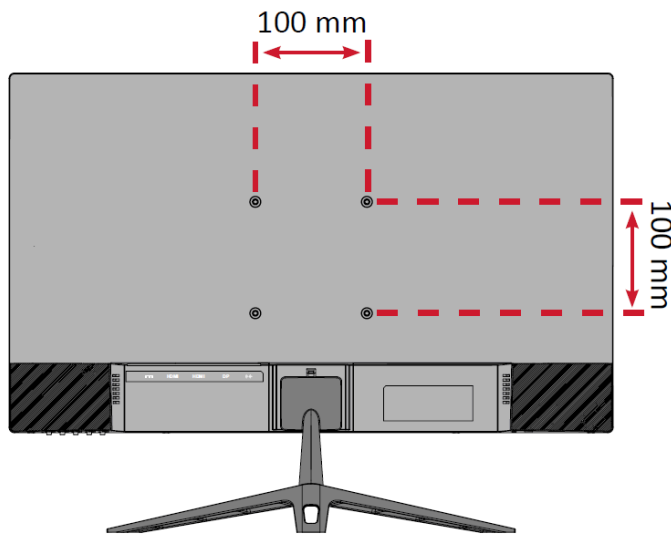

Maximum Loading	Hole Pattern (W x H)	Interface Pad (W x H x D)	Pad Hole	Screw Specification	Quantity
14 kg	100 x 100 mm	115 x 115 x 2.6 mm	Ø 5 mm	M4 x 10 mm	4 screws

1. Turn off the device and disconnect all cables.
2. Place the device on a flat, stable surface with the screen facing down.
3. Remove the monitor stand.

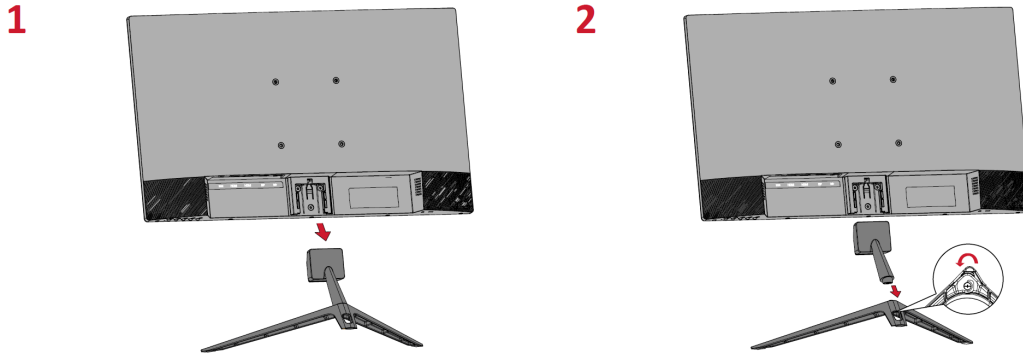

4. Attach the mounting bracket to the VESA mounting holes at the rear of the monitor. Then secure it with four (4) screws (M4 x 10 mm).
5. Follow the instructions that come with the mounting kit to mount the monitor onto the wall.

Using the Security Slot

To help prevent the device from being stolen, use a security slot locking device to secure the device to a fixed object.

Additionally, fastening the monitor to a wall or fixed object using a security cable can help support the weight of the monitor in order to prevent the monitor from falling over.

Below is an example of setting up a security slot locking device on a table.

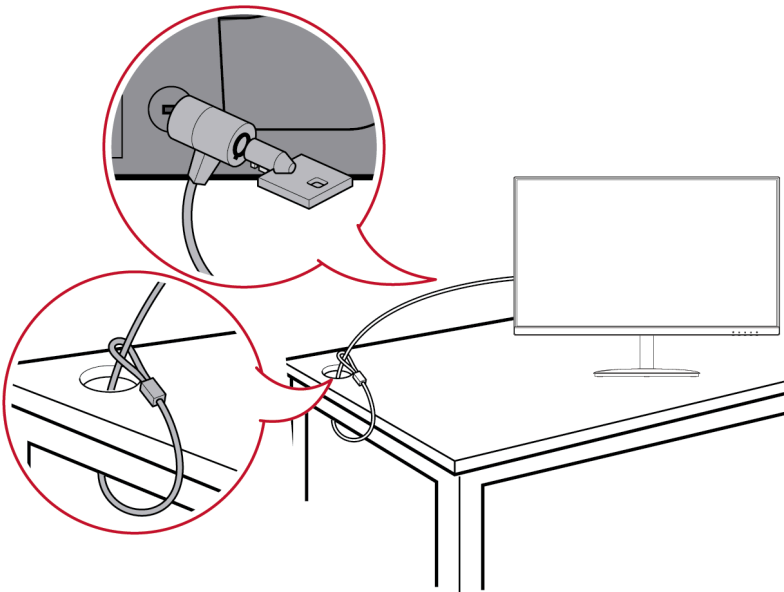

Connecting to Power

1. Connect the power cord to the DC IN jack at the rear of the device.
2. Plug in the power cord to a power outlet.

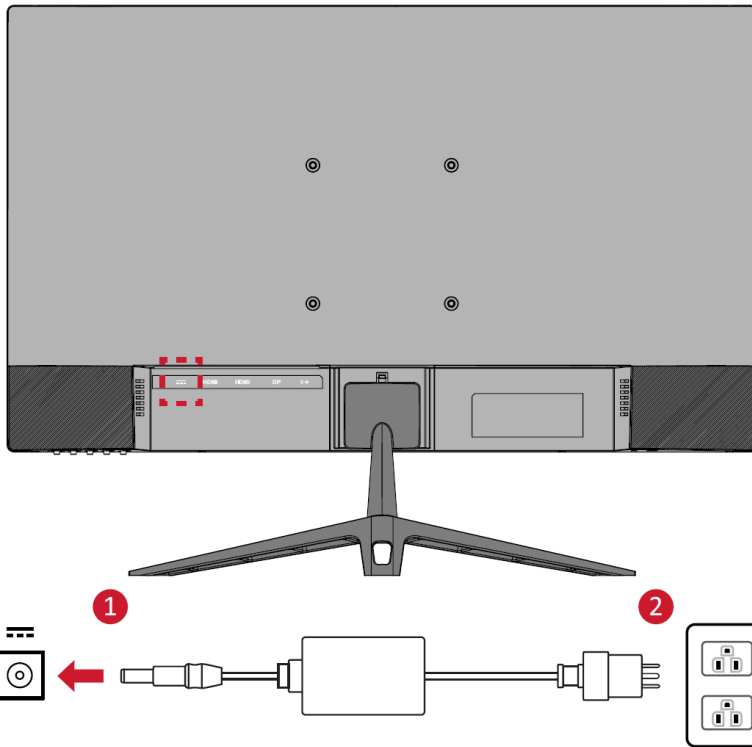

Connecting External Devices

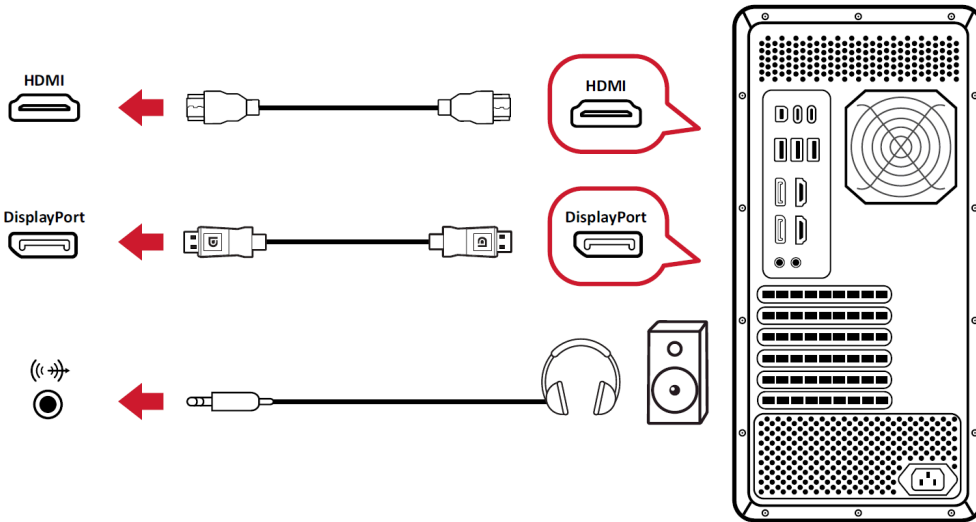
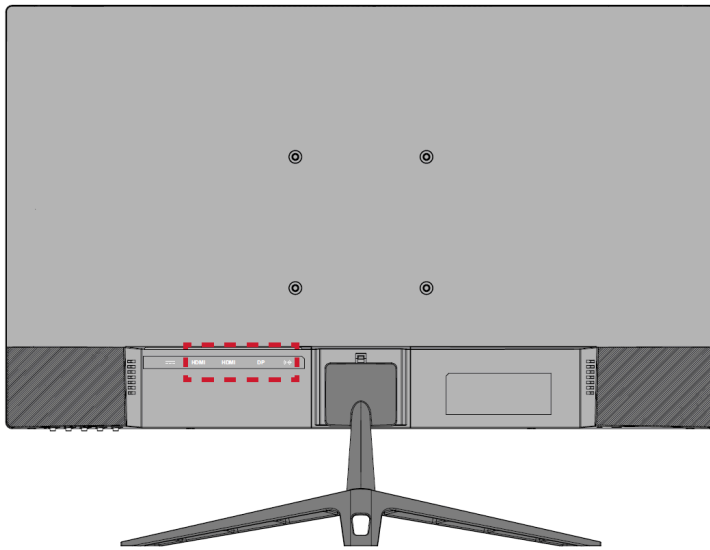

Tilt Angle Adjustment

Tilt the monitor backwards to the desired viewing angle via the attached stand (-5° to 20°).

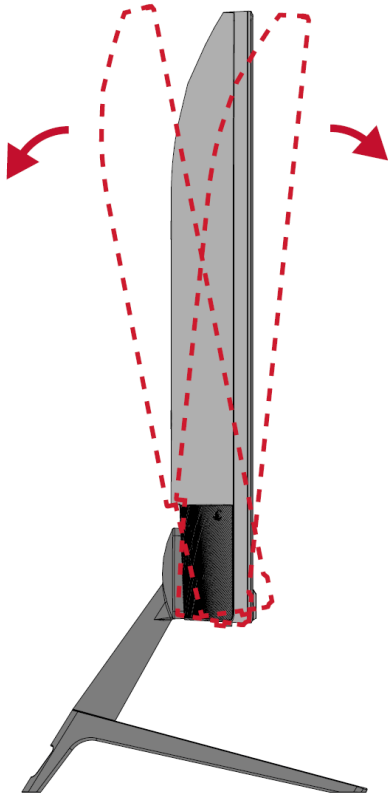

NOTE: When adjusting, support the monitor firmly with one hand while tilting the stand backwards with the other hand.

Turning the Device On/Off

1. Plug the power cord into a power outlet.
2. Press the **Power** button to turn on the monitor.
3. To turn the monitor off, press the **Power** button again.

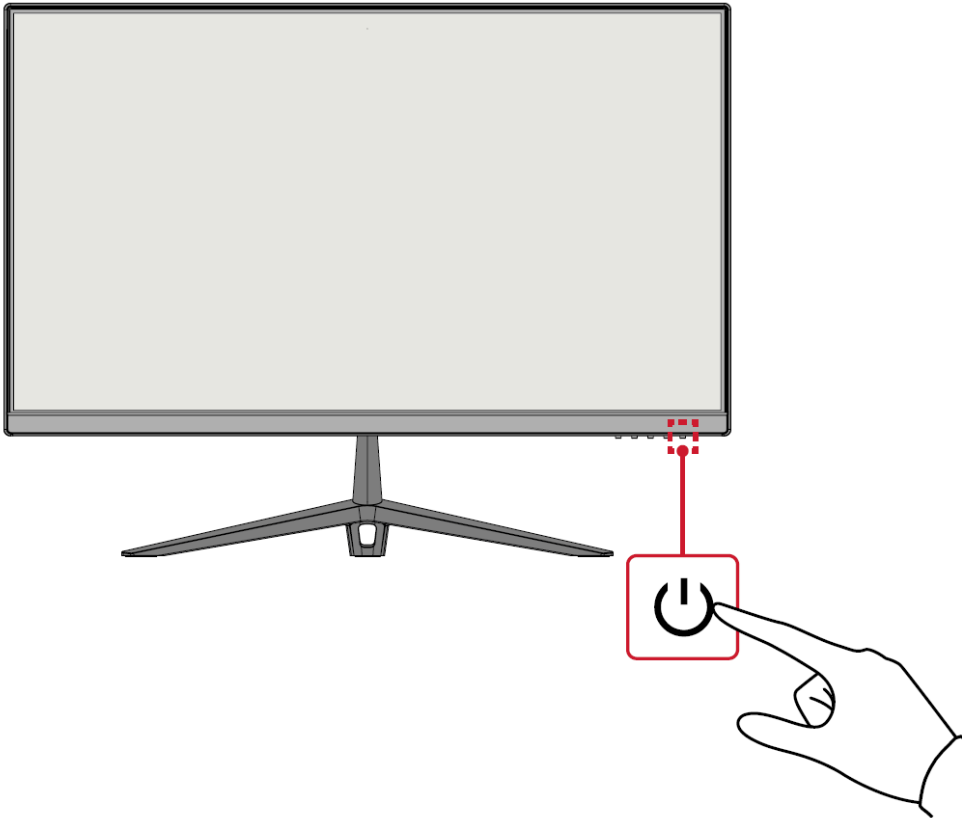

Using the Control Panel Keys

Use the control panel keys to access the Quick Menu, activate Hot Keys, navigate the On-Screen Display (OSD) Menu, and change the settings.

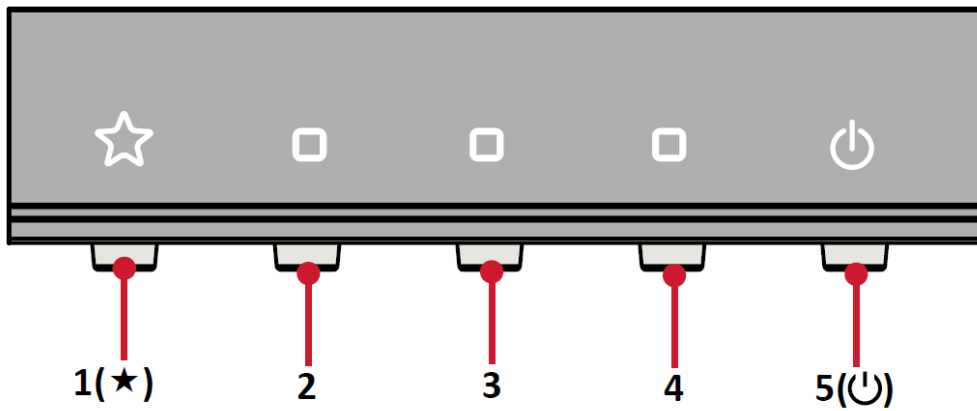



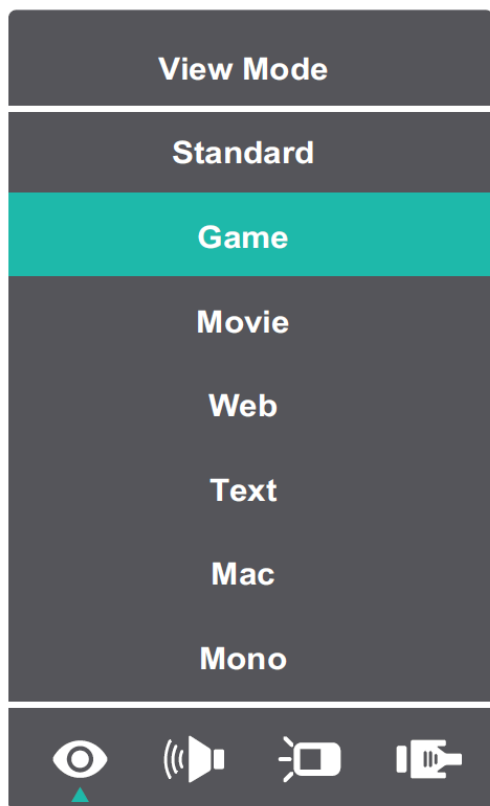

Quick Menu

Press the **1** key to activate the Quick Menu.



NOTE: Follow the key guide that appears on the screen to select the option or make adjustments.

Icon	Name	Description
	ViewMode	Select one of the preset color settings.
	Volume	Adjust the level, or mute the volume.
	Contrast / Brightness	Adjust the contrast or brightness.
	Input Select	Select the input source.
	Exit	Exit the Quick Menu.

Hot Keys

When the On-Screen Display (OSD) Menu is off, you can quickly access special functions by using the **Control Panel Keys**.

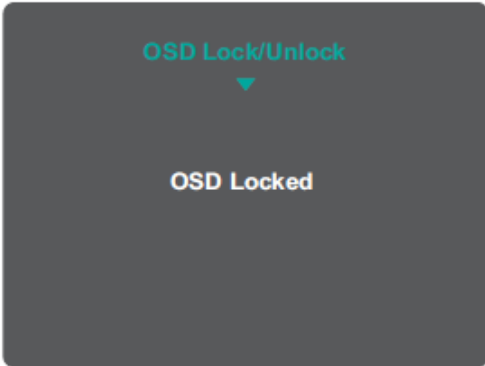
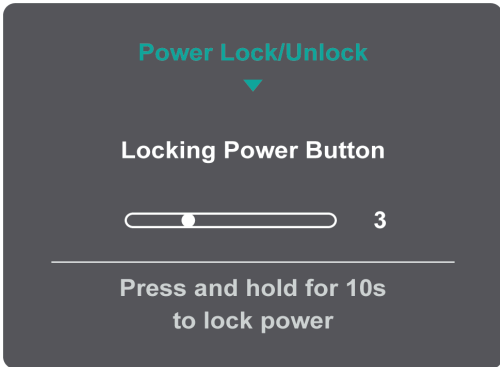
Key	Description
1 + 2	<p>Press and hold the keys to lock/unlock the OSD Menu.</p> <p>When the menu appears on the screen, continue holding the keys for 10 seconds to lock/unlock the OSD Menu.</p>  <p>If the OSD Menu is locked, the below message will appear on the screen:</p> 
2 + 3	<p>Press and hold the keys to lock/unlock the Power button.</p> <p>When the menu appears on the screen, continue holding the keys for 10 seconds to lock/unlock the Power button.</p>  <p>If the Power button is locked, the below message will appear on the screen:</p>

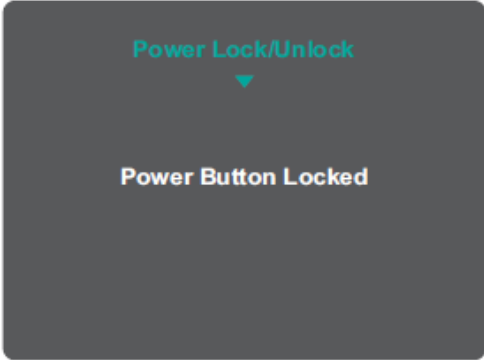
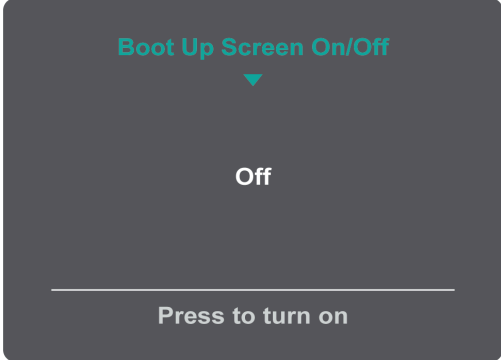
	
3 + 4	<p>Press the keys to display/hide the boot up screen when the device is turned on.</p> 

General Operation

1. Press the **2/3/4** key to display the On-Screen Display (OSD) Menu.

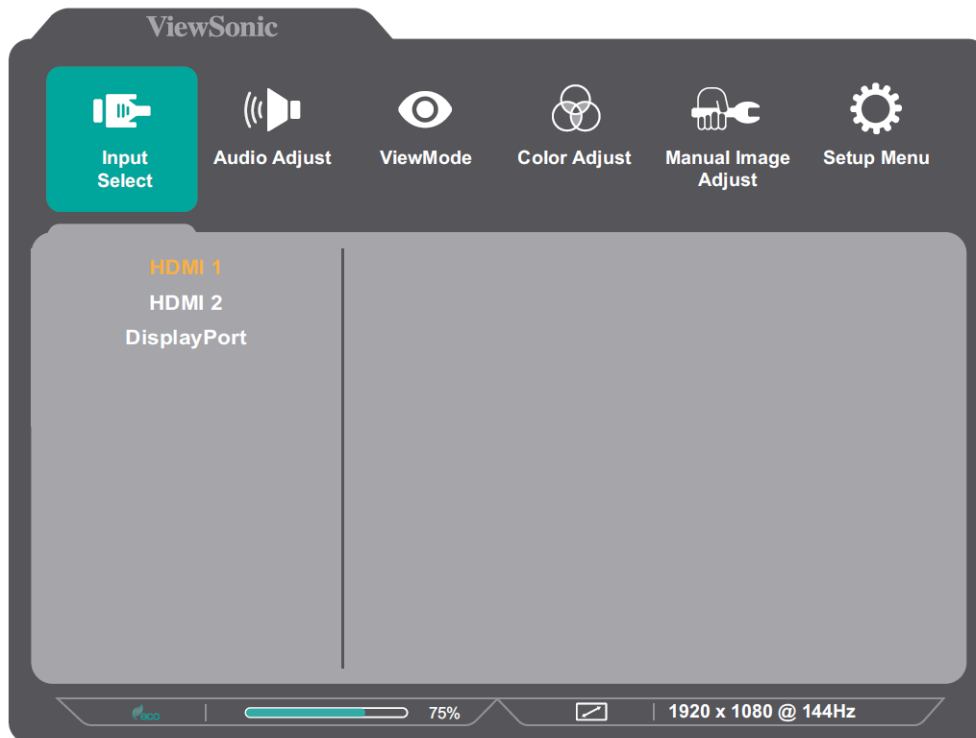

2. Press the **1** or **2** key to select the main menu. Then press the **3** key to enter the selected menu.

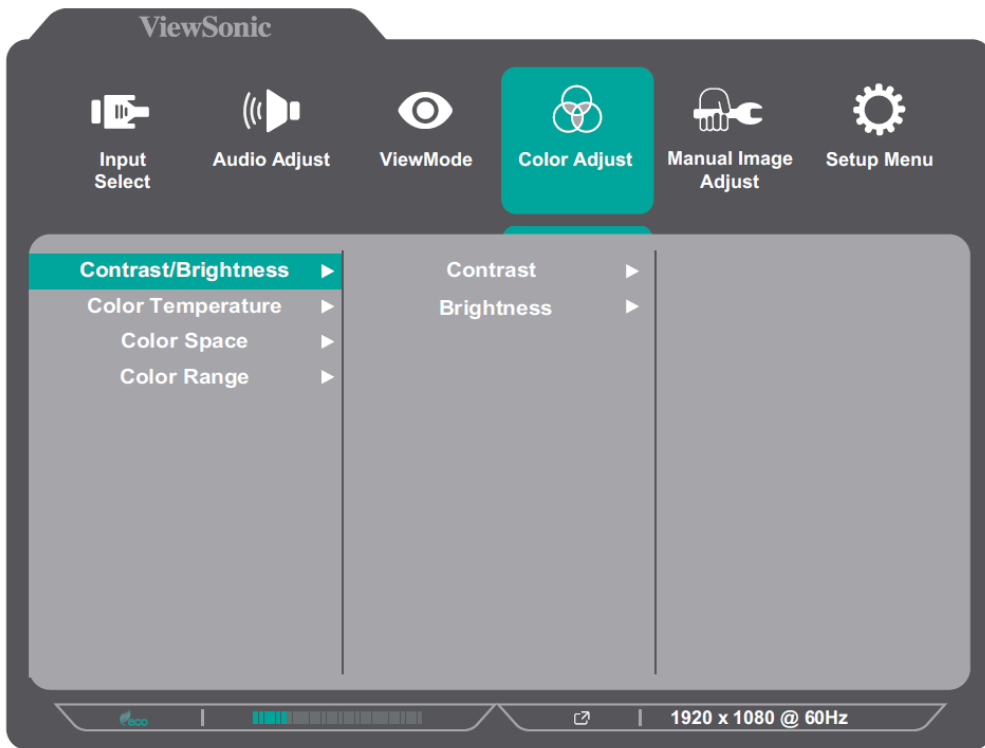

3. Press the **1** or **2** key to select the desired menu option. Then press the **3** key to enter the sub-menu.

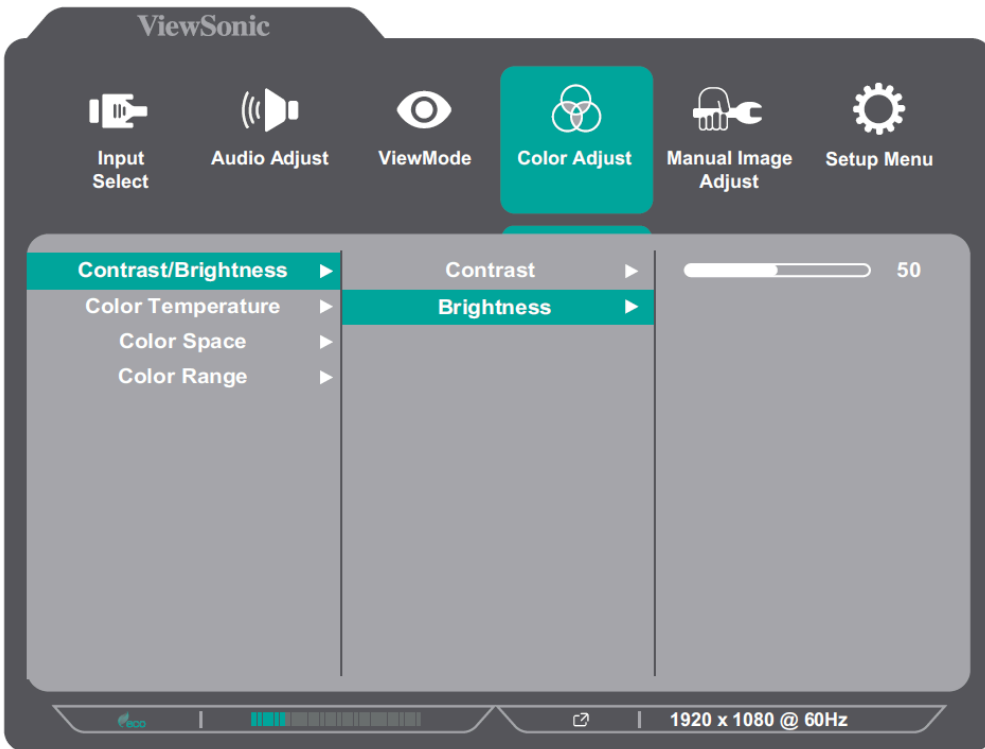

4. Press the **1** or **2** key to adjust/select the setting. Then press the **3** key to confirm.

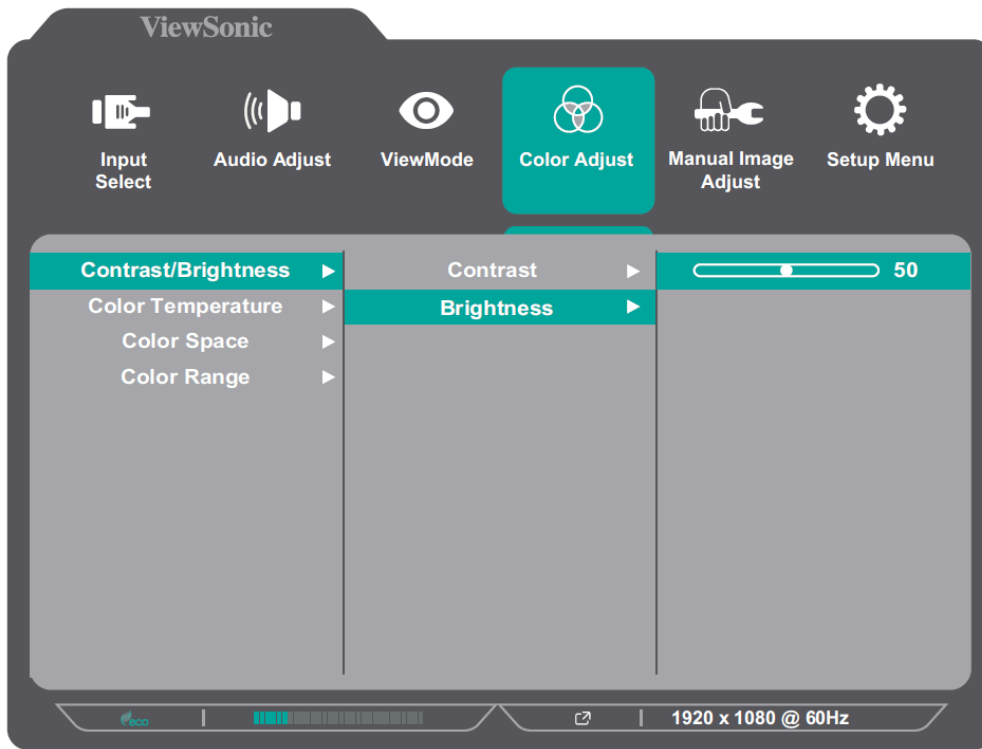

NOTE: Certain menu option adjustments do not require the user to press the **3** key to confirm the selection. Follow the key guide that appears on the bottom of the screen to select the option or make adjustments.

5. Press the **4** key to return to the previous menu.

NOTE: To exit the OSD Menu, press the **5** key.

On-Screen Display (OSD) Menu Tree

Input Select Audio Adjust ViewMode Color Adjust Manual Image Adjust Setup M

Sub-menu
HDMI 1
HDMI 2
DisplayPort

Technical Specifications

Item	Category	Specifications
Model	P/N.	VX2428
	No.	VS19276
LCD	Type	IPS, Color a-Si TFT Active Matrix 1920 x 1080 LCD; 0.2745 (H)mm x 0.2745 (V)mm pixel pitch
	Display Size	60.45 cm (23.8" viewable)
	Color Filter	RGB vertical stripe
	Glass Surface	Anti-Glare (Haze 25%), Hard Coating (3H)
Input Signal	Video Sync	<u>TMDS digital (100 Ω)</u> DisplayPort: fh:24~183 kHz, fv:48~180 Hz HDMI: fh:30~160 kHz, fv:48~180 Hz
Compatibility	PC	up to 1920 x 1080
	Macintosh	up to 1920 x 1080

Resolution^[1]	Recommended	1920 x 1080 @ 165Hz
	Supported	<ul style="list-style-type: none"> ▪ 1920 x 1080 @ 50, 60, 75, 100, 120, 144, 165, 180Hz ▪ 1680 x 1050 @ 60Hz ▪ 1600 x 1200 @ 60Hz ▪ 1600 x 900 @ 60Hz ▪ 1440 x 900 @ 60, 75Hz ▪ 1440 x 576 @ 50Hz ▪ 1400 x 1050 @ 60, 75Hz ▪ 1366 x 768 @ 60Hz ▪ 1360 x 768 @ 60Hz ▪ 1280 x 1024 @ 50, 60, 75Hz ▪ 1280 x 960 @ 50, 60, 75Hz ▪ 1280 x 800 @ 60, 75Hz ▪ 1280 x 768 @ 50, 60, 75Hz ▪ 1280 x 720 @ 50, 60Hz ▪ 1152 x 900 @ 66Hz ▪ 1152 x 870 @ 75Hz ▪ 1152 x 864 @ 60, 75Hz ▪ 1024 x 768 @ 50, 60, 70, 72, 75Hz ▪ 1024 x 600 @ 60Hz ▪ 848 x 480 @ 60Hz ▪ 832 x 624 @ 75Hz ▪ 800 x 600 @ 56, 60, 72, 75Hz ▪ 720 x 576 @ 50Hz ▪ 720 x 480 @ 60Hz ▪ 720 x 400 @ 70Hz ▪ 640 x 480 @ 50, 60, 67, 73, 75Hz ▪ 640 x 400 @ 60, 70Hz ▪ 640 x 350 @ 70Hz
Power^[2]	Input Voltage	AC 100-240V, 50/60Hz (auto switch)
Display Area	Full Scan (H x V)	534.65 x 308.06 mm (21.05" x 12.13")
Audio	Speaker	2 x 2W
Operating Conditions	Temperature	0° C to 40° C (32° F to 104° F)
	Humidity	10% to 90% (non-condensing)
	Altitude	16,000 feet (5 km)
Storage Conditions	Temperature	-20° C to 60° C (-4° F to 140° F)
	Humidity	5% to 90% (non-condensing)
	Altitude	40,000 feet (12.1 km)

Dimensions	Physical (W x H x D)	541.86 x 413 x 182.5 mm (21.33" x 16.26" x 7.19")
Wall Mount	Dimensions	100 x 100 mm
Weight	Physical	4.4 kg (9.9 lbs.)
Power Saving Modes	On ^[3]	28W (Typical)
	Off	≤ 0.3W

1. Do not set the graphics card in your computer to exceed these timing modes; doing so may result in permanent damage to the display.
2. Please use the power adapter from ViewSonic® or an authorized source only.
3. The test condition follows EEI standards.

Compliance Information

This section addresses all connected requirements and statements regarding regulations. Confirmed corresponding applications shall refer to nameplate labels and relevant markings on the unit.

FCC Compliance Statement

This device complies with part 15 of FCC Rules. Operation is subject to the following two conditions: (1) this device may not cause harmful interference, and (2) this device must accept any interference received, including interference that may cause undesired operation. This equipment has been tested and found to comply with the limits for a Class B digital device, pursuant to part 15 of the FCC Rules.

These limits are designed to provide reasonable protection against harmful interference in a residential installation. This equipment generates, uses, and can radiate radio frequency energy, and if not installed and used in accordance with the instructions, may cause harmful interference to radio communications. However, there is no guarantee that interference will not occur in a particular installation. If this equipment does cause harmful interference to radio or television reception, which can be determined by turning the equipment off and on, the user is encouraged to try to correct the interference by one or more of the following measures:

- Reorient or relocate the receiving antenna.
- Increase the separation between the equipment and receiver.
- Connect the equipment into an outlet on a circuit different from that to which the receiver is connected.
- Consult the dealer or an experienced radio/TV technician for help.

Warning: You are cautioned that changes or modifications not expressly approved by the party responsible for compliance could void your authority to operate the equipment.

Industry Canada Statement

CE Conformity for European Countries



The device complies with the EMC Directive 2014/30/EU and Low Voltage Directive 2014/35/EU.

The following information is only for EU-member states:

The mark shown to the right is in compliance with the Waste Electrical and Electronic Equipment Directive 2012/19/EU (WEEE). The mark indicates the requirement NOT to dispose of the equipment as unsorted municipal waste, but use the return and collection systems according to local law.

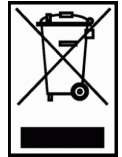

Declaration of RoHS2 Compliance

This product has been designed and manufactured in compliance with Directive 2011/65/EU of the European Parliament and the Council on restriction of the use of certain hazardous substances in electrical and electronic equipment (RoHS2 Directive) and is deemed to comply with the maximum concentration values issued by the European Technical Adaptation Committee (TAC) as shown below:

Substance	Proposed Maximum Concentration	Actual Concentration
Lead (Pb)	0.1%	< 0.1%
Mercury (Hg)	0.1%	< 0.1%
Cadmium (Cd)	0.01%	< 0.01%
Hexavalent Chromium (Cr6 ⁺)	0.1%	< 0.1%
Polybrominated biphenyls (PBB)	0.1%	< 0.1%
Polybrominated diphenyl ethers (PBDE)	0.1%	< 0.1%
Bis (2-ethylhexyl) phthalate (DEHP)	0.1%	< 0.1%
Butyl benzyl phthalate (BBP)	0.1%	< 0.1%
Dibutyl phthalate (DBP)	0.1%	< 0.1%
Diisobutyl phthalate (DIBP)	0.1%	< 0.1%

Certain components of products as stated above are exempted under the Annex III of the RoHS2 Directives as noted below. Examples of exempted components are:

- Copper alloy containing up to 4% lead by weight.
- Lead in high melting temperature type solders (i.e. lead-based alloys containing 85% by weight or more lead).
- Electrical and electronic components containing lead in a glass or ceramic other than dielectric ceramic in capacitors, e.g. piezoelectric devices, or in a glass or ceramic matrix compound.
- Lead in dielectric ceramic in capacitors for a rated voltage of 125V AC or 250V DC or higher.

Indian Restriction of Hazardous Substances

Restriction on Hazardous Substances statement (India). This product complies with the “India E-waste Rule 2011” and prohibits use of lead, mercury, hexavalent chromium, polybrominated biphenyls or polybrominated diphenyl ethers in concentrations exceeding 0.1 weight % and 0.01 weight % for cadmium, except for the exemptions set in Schedule 2 of the Rule.

Product Disposal at End of Product Life

ViewSonic® respects the environment and is committed to working and living green. Thank you for being part of Smarter, Greener Computing. Please visit the ViewSonic® website to learn more.

USA & Canada

<https://www.viewsonic.com/us/go-green-with-viewsonic> <

<https://www.viewsonic.com/us/go-green-with-viewsonic>>

Europe

<https://www.viewsonic.com/eu/environmental-social-governance/recycle> <

<https://www.viewsonic.com/eu/environmental-social-governance/recycle>>

Taiwan

<https://recycle.moenv.gov.tw> < <https://recycle.moenv.gov.tw>>

For EU users, please contact us for any safety/accident issue experienced with this product:

ViewSonic Europe Limited



Haaksbergweg 75

1101 BR Amsterdam

Netherlands



+31 (0) 650608655



EPREL@viewsoniceurope.com



<https://www.viewsonic.com/eu/> < <https://www.viewsonic.com/eu/>>

Copyright Information

Copyright© ViewSonic® Corporation, 2023. All rights reserved.

Macintosh and Power Macintosh are registered trademarks of Apple Inc.

Microsoft, Windows, and the Windows logo are registered trademarks of Microsoft Corporation in the United States and other countries.

ViewSonic®, the three birds logo, OnView, ViewMatch, and ViewMeter are registered trademarks of ViewSonic® Corporation.

VESA is a registered trademark of the Video Electronics Standards Association. DPMS, DisplayPort, and DDC are trademarks of VESA.

Disclaimer: ViewSonic® Corporation shall not be liable for technical or editorial errors or omissions contained herein; nor for incidental or consequential damages resulting from furnishing this material, or the performance or use of this product.

In the interest of continuing product improvement, ViewSonic® Corporation reserves the right to change product specifications without notice. Information in this document may change without notice.

No part of this document may be copied, reproduced, or transmitted by any means, for any purpose without prior written permission from ViewSonic® Corporation.

VX2428_UG_ENG_1a_20230605

Customer Service Contact Information

For technical support or product service, see the table below or contact your reseller.

You will need the product's serial number

Asia Pacific & Africa

Country / Region	Website
Australia	https://viewsonic.com/au/ < https://viewsonic.com/au/ >
Bangladesh	https://www.viewsonic.com/bd/ < https://www.viewsonic.com/bd/ >
中国(China)	https://www.viewsonic.com.cn < https://www.viewsonic.com.cn >
香港 (繁體中文)	https://www.viewsonic.com/hk/ < https://www.viewsonic.com/hk/ >
Hong Kong (English)	https://www.viewsonic.com/hk-en/ < https://www.viewsonic.com/hk-en/ >
India	https://www.viewsonic.com/in/ < https://www.viewsonic.com/in/ >
Indonesia	https://www.viewsonic.com/id/ < https://www.viewsonic.com/id/ >
Israel	https://www.viewsonic.com/il/ < https://www.viewsonic.com/il/ >
日本 (Japan)	https://www.viewsonic.com/jp/ < https://www.viewsonic.com/jp/ >
Korea	https://www.viewsonic.com/kr/ < https://www.viewsonic.com/kr/ >
Malaysia	https://www.viewsonic.com/my/ < https://www.viewsonic.com/my/ >
Middle East	https://www.viewsonic.com/me/ < https://www.viewsonic.com/me/ >
Myanmar	https://www.viewsonic.com/mm/ < https://www.viewsonic.com/mm/ >
Nepal	https://www.viewsonic.com/np/ < https://www.viewsonic.com/np/ >
New Zealand	https://www.viewsonic.com/nz/ < https://www.viewsonic.com/nz/ >
Pakistan	https://www.viewsonic.com/pk/ < https://www.viewsonic.com/pk/ >
Philippines	https://www.viewsonic.com/ph/ < https://www.viewsonic.com/ph/ >

Singapore	https://www.viewsonic.com/sg/ < https://www.viewsonic.com/sg/ >
臺灣 (Taiwan)	https://www.viewsonic.com/tw/ < https://www.viewsonic.com/tw/ >
ประเทศไทย (Thailand)	https://www.viewsonic.com/th/ < https://www.viewsonic.com/th/ >
Việt Nam	https://www.viewsonic.com/vn/ < https://www.viewsonic.com/vn/ >
South Africa & Mauritius	https://www.viewsonic.com/za/ < https://www.viewsonic.com/za/ >

Americas

Country / Region	Website
United States	https://www.viewsonic.com/us/ < https://www.viewsonic.com/us/ >
Canada	https://www.viewsonic.com/us/ < https://www.viewsonic.com/us/ >
Latin America	https://www.viewsonic.com/la/ < https://www.viewsonic.com/la/ >

Europe

Country / Region	Website
Europe	https://www.viewsonic.com/eu/ < https://www.viewsonic.com/eu/ >
France	https://www.viewsonic.com/fr/ < https://www.viewsonic.com/fr/ >
Deutschland	https://www.viewsonic.com/de/ < https://www.viewsonic.com/de/ >
Қазақстан	https://www.viewsonic.com/kz/ < https://www.viewsonic.com/kz/ >
Россия	https://www.viewsonic.com/ru/ < https://www.viewsonic.com/ru/ >
España	https://www.viewsonic.com/es/ < https://www.viewsonic.com/es/ >
Türkiye	https://www.viewsonic.com/tr/ < https://www.viewsonic.com/tr/ >
Україна	https://www.viewsonic.com/ua/ < https://www.viewsonic.com/ua/ >

Limited Warranty

ViewSonic® Display

What the warranty covers:

ViewSonic® warrants its products to be free from defects in material and workmanship during the warranty period. If a product proves to be defective in material or workmanship during the warranty period, ViewSonic® will, at its sole option, and as your sole remedy, repair or replace the product with a similar product. Replacement Product or parts may include remanufactured or refurbished parts or components. The repair or replacement unit or parts or components will be covered by the balance of the time remaining on the customer's original limited warranty and the warranty period will not be extended. ViewSonic® provides no warranty for any third-party software whether included with the product or installed by the customer, installation of any unauthorized hardware parts or components (e.g. Projector Lamps). (Please refer to: "What the warranty excludes and does not cover" section).

How long the warranty is effective:

ViewSonic® displays are warranted for between 1 and 3 years, depending on your country of purchase, for all parts including the light source and for all labor from the date of the first consumer purchase.

Who the warranty protects:

This warranty is valid only for the first consumer purchaser.

What the warranty excludes and does not cover:

- Any product on which the serial number has been defaced, modified, or removed.
- Damage, deterioration, or malfunction resulting from:
 - Accident, misuse, neglect, fire, water, lightning, or other acts of nature, unauthorized product modification, or failure to follow instructions supplied with the product.
 - Repair or attempted repair by anyone not authorized by ViewSonic®.
 - Damage to or loss of any programs, data, or removable storage media.
 - Normal wear and tear.
 - Removal or installation of the product.
- Software or data loss occurring during repair or replacement.
- Any damage of the product due to shipment.

- Causes external to the product, such as electric power fluctuations or failure.
- Use of supplies or parts not meeting ViewSonic's specifications.
- Failure of owner to perform periodic product maintenance as stated in the User Guide.
- Any other cause which does not relate to a product defect.
- Damage caused by static (non-moving) images displayed for lengthy periods of time (also referred to as image burn-in).
- Software - Any third-party software included with the product or installed by the customer.
- Hardware/Accessories/Parts/Components – Installation of any unauthorized hardware, accessories, consumable parts or components (e.g. Projector Lamps).
- Damage to, or abuse of, the coating on the surface of the display through inappropriate cleaning as described in the product User Guide.
- Removal, installation, and set-up service charges, including wall-mounting of the product.

How to get service:

- For information about receiving service under warranty, contact ViewSonic® Customer Support (Please refer to the "Customer Service" page). You will need to provide your product's serial number.
- To obtain warranty service, you will be required to provide: (a) the original dated sales slip, (b) your name, (c) your address, (d) a description of the problem, and (e) the serial number of the product.
- Take or ship the product, freight prepaid, in the original container to an authorized ViewSonic® service center or ViewSonic®.
- For additional information or the name of the nearest ViewSonic® service center, contact ViewSonic®.

Limitation of implied warranties:

There are no warranties, express or implied, which extend beyond the description contained herein including the implied warranty of merchantability and fitness for a particular purpose.

Exclusion of damages:

ViewSonic's liability is limited to the cost of repair or replacement of the product. ViewSonic® shall not be liable for:

- Damage to other property caused by any defects in the product, damages based upon inconvenience, loss of use of the product, loss of time, loss of profits, loss of business opportunity, loss of goodwill, interference with business relationships, or other commercial loss, even if advised of the possibility of such damages.
- Any other damages, whether incidental, consequential or otherwise.
- Any claim against the customer by any other party.
- Repair or attempted repair by anyone not authorized by ViewSonic®.

Effect of state law:

This warranty gives you specific legal rights, and you may also have other rights which vary from state to state. Some states do not allow limitations on implied warranties and/or do not allow the exclusion of incidental or consequential damages, so the above limitations and exclusions may not apply to you.

Sales outside the U.S.A. and Canada:

For warranty information and service on ViewSonic® products sold outside of the U.S.A. and Canada, contact ViewSonic® or your local ViewSonic® dealer. The warranty period for this product in mainland China (Hong Kong, Macao, and Taiwan Excluded) is subject to the terms and conditions of the Maintenance Guarantee Card. For users in Europe and Russia, full details of warranty provided can be found at: **ViewSonic EU (<http://www.viewsonic.com/eu/>)** under "Support/Warranty Information".

Mexico Limited Warranty

ViewSonic® Display

What the warranty covers:

ViewSonic® warrants its products to be free from defects in material and workmanship, under normal use, during the warranty period. If a product proves to be defective in material or workmanship during the warranty period, ViewSonic® will, at its sole option, repair or replace the product with a like product. Replacement product or parts may include remanufactured or refurbished parts or components & accessories.

How long the warranty is effective:

ViewSonic® LCD displays are warranted for between 1 and 3 years, depending on your country of purchase, for all parts including the light source and for all labour from the date of the first consumer purchase.

Who the warranty protects:

This warranty is valid only for the first consumer purchaser.

What the warranty excludes and does not cover:

- Any product on which the serial number has been defaced, modified, or removed.
- Damage, deterioration, or malfunction resulting from:
 - Accident, misuse, neglect, fire, water, lightning, or other acts of nature, unauthorized product modification, or failure to follow instructions supplied with the product.
 - Causes external to the product, such as electrical power fluctuations or failure.
 - Use of supplies or parts not meeting ViewSonic®'s specifications.
 - Normal wear and tear.
 - Removal or installation of the product.

How to get service:

- For information about receiving service under warranty, contact ViewSonic® Customer Support (Please refer to the "Customer Service" page). You will need to provide your product's serial number, so please record the product information in the space provided below on your purchase for your future use. Please retain your receipt of proof of purchase to support your warranty claim.
- To obtain warranty service, you will be required to provide: (a) the original dated sales slip, (b) your name, (c) your address, (d) a description of the problem, and (e) the serial number of the product.
- Take or ship the product, freight prepaid, in the original container to an authorized ViewSonic® service center.
- Round trip transportation costs for in-warranty products will be paid by ViewSonic®.

Limitation of implied warranties:

There are no warranties, express or implied, which extend beyond the description contained herein including the implied warranty of merchantability and fitness for a particular purpose.

Exclusion of damages:

ViewSonic®'s liability is limited to the cost of repair or replacement of the product. ViewSonic® shall not be liable for:

- Damage to other property caused by any defects in the product, damages based upon inconvenience, loss of use of the product, loss of time, loss of profits, loss of business opportunity, loss of goodwill, interference with business relationships, or other commercial loss, even if advised of the possibility of such damages.
- Any other damages, whether incidental, consequential or otherwise.
- Any claim against the customer by any other party.
- Repair or attempted repair by anyone not authorized by ViewSonic®.

**Contact Information for Sales & Authorized Service (Centro Autorizado de Servicio)
within Mexico:**

Name, address, of manufacturer and importers:

México, Av. de la Palma #8 Piso 2 Despacho 203, Corporativo Interpalmas,
Col. San Fernando Huixquilucan, Estado de México

Tel: (55) 3605-1099 <http://www.viewsonic.com/la/soporte/index.htm> <
<http://www.viewsonic.com/la/soporte/index.htm>>

NÚMERO GRATIS DE ASISTENCIA TÉCNICA PARA TODO MÉXICO: 001.866.823.2004

Hermosillo:

Distribuciones y Servicios
Computacionales SA de CV.
Calle Juarez 284 local 2
Col. Bugambilias C.P: 83140
Tel: 01-66-22-14-9005

E-Mail:

disc2@hmo.megared.net.mx
(mailto:disc2@hmo.megared.net.mx)

Villahermosa:

Compumantenimientos Garantizados, S.A.
de C.V.

AV. GREGORIO MENDEZ #1504

COL, FLORIDA C.P. 86040

Tel: 01 (993) 3 52 00 47 / 3522074 / 3 52
20 09

E-Mail:

compumantenimientos@prodigy.net.mx
(mailto:compumantenimientos@prodigy.net.mx)

Puebla, Pue. (Matriz):

RENTA Y DATOS, S.A. DE C.V.

Domicilio:

29 SUR 721 COL. LA PAZ

72160 PUEBLA, PUE.

Tel: 01(52).222.891.55.77 CON
10 LINEAS

E-Mail:

datos@puebla.megared.net.mx
(mailto:datos@puebla.megared.net.mx)

Veracruz, Ver.:

CONEXION Y DESARROLLO, S.A DE
C.V. Av.

Americas # 419

ENTRE PINZÓN Y ALVARADO

Fracc. Reforma C.P. 91919

Tel: 01-22-91-00-31-67

E-Mail: gacosta@qplus.com.mx (mailto:
gacosta@qplus.com.mx)

Chihuahua:

Soluciones Globales en
Computación

C. Magisterio # 3321 Col.

Magisterial

Chihuahua, Chih.

Tel: 4136954

E-Mail:

Cefeo@soluglobales.com (mailto:
Cefeo@soluglobales.com)

Cuernavaca:

Compusupport de Cuernavaca SA de CV

Francisco Leyva # 178 Col. Miguel Hidalgo

C.P. 62040, Cuernavaca Morelos

Tel: 01 777 3180579 / 01 777 3124014

E-Mail:

aquevedo@compusupportcva.com (mailto:
aquevedo@compusupportcva.com)

<p>Distrito Federal: QPLUS, S.A. de C.V. Av. Coyoacán 931 Col. Del Valle 03100, México, D.F. Tel: 01(52)55-50-00-27-35 E-Mail : gacosta@qplus.com.mx (mailto: gacosta@qplus.com.mx)</p>	<p>Guadalajara, Jal.: SERVICRECE, S.A. de C.V. Av. Niños Héroes # 2281 Col. Arcos Sur, Sector Juárez 44170, Guadalajara, Jalisco Tel: 01(52)33-36-15-15-43 E-Mail: mmiranda@servicrece.com (mailto: mmiranda@servicrece.com)</p>
<p>Guerrero Acapulco: GS Computación (Grupo Sesicomp) Progreso #6-A, Colo Centro 39300 Acapulco, Guerrero Tel: 744-48-32627</p>	<p>Monterrey: Global Product Services Mar Caribe # 1987, Esquina con Golfo Pérsico Fracc. Bernardo Reyes, CP 64280 Monterrey N.L. México Tel: 8129-5103 E-Mail: aydeem@gps1.com.mx (mailto: aydeem@gps1.com.mx)</p>
<p>MERIDA: ELECTROSER Av Reforma No. 403Gx39 y 41 Mérida, Yucatán, México CP97000 Tel: (52) 999-925-1916 E-Mail: rrrb@sureste.com (mailto: rrrb@sureste.com)</p>	<p>Oaxaca, Oax.: CENTRO DE DISTRIBUCION Y SERVICIO, S.A. de C.V. Murguía # 708 P.A., Col. Centro, 68000, Oaxaca Tel: 01(52)95-15-15-22-22 Fax: 01(52)95-15-13-67-00 E-Mail. gpotai2001@hotmail.com (mailto: gpotai2001@hotmail.com)</p>
<p>Tijuana: STD Av Ferrocarril Sonora #3780 L-C Col 20 de Noviembr Tijuana, Mexico</p>	<p>FOR USA SUPPORT: ViewSonic® Corporation 381 Brea Canyon Road, Walnut, CA. 91789 USA Tel: 800-688-6688 http://www.viewsonic.com < http://www.viewsonic.com></p>

Using the Monitor Safely

Please read these instructions completely before using the equipment.

- Keep this user guide in a safe place for later reference.
- Read all warnings and follow all instructions.
- Sit at least 18" (45 cm) away from the device.
- Allow at least 4" (10 cm) clearance around the device to ensure proper ventilation.
- Place the device in a well-ventilated area. Do not place anything on the device that prevents heat dissipation.
- Do not use the device near water. To reduce the risk of fire or electric shock, do not expose the device to moisture.
- Avoid exposing the device to direct sunlight or other sources of sustained heat.
- Do not install near any heat sources such as radiators, heat registers, stoves, or other devices (including amplifiers) that may increase the temperature of the device to dangerous levels.
- Use a soft, dry cloth to clean the external housing. For more information, refer to the "Maintenance" section of this manual.
- Avoid touching the screen, as oil may collect on the screen if you touch it.
- Do not touch the screen surface with sharp or hard objects, as it may cause damage to the screen.
- Do not place the device on cloth or other materials that may be placed between the product and supporting furniture.
- When moving the device, be careful not to drop or bump the device on anything.
- Always route and manage cords and cables connected to your device so they cannot be tripped over, pulled, or grabbed.
- Protect the power cord from being treaded upon or pinched, particularly at the plug, and at the point where it emerges from the equipment. Ensure that the power outlet is located near the equipment so that it is easily accessible.
- Disconnect the power plug from the power outlet if the device is not being used for a long period of time.
- Please confirm the distribution system installed in the building. The system should provide a circuit breaker rated at 120/240V, 20A.
- Only use attachments/accessories, such as carts, stands, tripods, brackets or tables, specified by the manufacturer.
- When a cart is used, use with caution when moving the cart/equipment combination to avoid injury from tipping over.
- Refer all servicing to qualified service personnel. Service will be required when the unit has been damaged in any way, such as:
 - if the power-supply cord or plug is damaged.
 - if liquid is spilled onto or objects fall into the unit.
 - if the unit is exposed to rain or moisture.
 - if the unit does not operate normally or has been dropped.

- Do not place the device on an uneven or unstable surface. The device may fall over resulting in an injury or a malfunction.
- Do not place any heavy objects on the device or connection cables.
- Always use cabinets, stands, or installation methods recommended by the manufacturer of the device set.
- Always use furniture that can safely support the device.
- Always ensure the device is not overhanging the edge of the supporting furniture.
- Do not place the device on tall furniture, such as cupboards or bookcases, without anchoring both the furniture and the device to a suitable support.
- Always educate children about the dangers of climbing on furniture to reach the device or related equipment.
- Do not place the monitor where children are likely to be present.
- Do not place items that might tempt children to climb, such as toys and remote controls, on the top of the device or furniture on which the product is placed.
- If smoke, an abnormal noise, or a strange odor is present, immediately turn the device off and call your dealer or ViewSonic®. It is dangerous to continue using the device.
- Do not attempt to circumvent the safety provisions of the polarized or grounding-type plug. A polarized plug has two blades with one wider than the other. A grounding-type plug has two blades and a third grounding prong. The wide blade and the third prong are provided for your
- When using ear-/headphones, adjust the volume to appropriate levels, or hearing damage may result.
- Stability Hazard: The display may fall, causing serious personal injury or death. To prevent injury, this display must be securely attached to the floor/wall in accordance with the installation instructions.
- Fastening the display to a wall or fixed object using cordage or other restraining devices can help support the weight of the display in order to prevent the display from falling over.

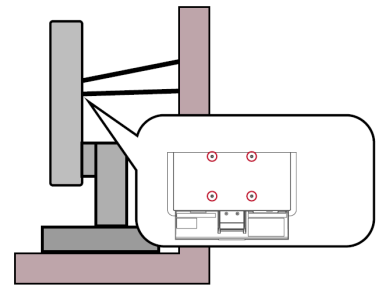

safety. If the plug does not fit into your outlet, obtain an adapter and do not attempt to force the plug into the outlet.

- When connecting to a power outlet, Do not remove the grounding prong. Please ensure grounding prongs are never removed.

NOTE:

- Restraining device/cordage should be able to withstand 100N force.
 - Make sure the cordage is straightened, and any slack is removed. The back of the device shall face the wall to ensure the device cannot tilt under external force.
 - Make sure the display does not tilt under external force at any height and rotation angle of the device.
-
- If the existing display is going to be retained and relocated, the same considerations as above should be applied.

Glossary of Terms

NOTE: Some terms may not be applicable to your device.

ABCFGHILMOPRSTUVY1

Advanced DCR

Advanced DCR technology automatically detects the image signal and intelligently controls the backlight brightness and color to improve on the ability to make the black blacker in a dark scene, and make the white whiter in a bright environment.

Advanced Gamma

Allows the user to manually adjust the brightness level of the monitor's grayscale levels. There are five selections: 1.8, 2.0, 2.2, 2.4, and 2.6.

Advanced Sharpness

Adjusts the picture quality of the monitor, with a range of 0 to 100.

All Recall

Returns the adjustments back to factory settings if the display is operating in a factory Preset Timing Mode listed in the Specifications of this manual.

Audio Adjust

Adjusts the volume, mutes the sound, or toggles between inputs if you have more than one source.

Troubleshooting Common Problems

Why is there no power?	▼
Why is there no image on screen?	▼
What should I do if the colors are wrong or abnormal?	▼
How do I adjust the screen when it is too bright or dark?	▼
What should I do if the screen image cuts in and out?	▼
The screen image is blurry, now what?	▼
How to center the screen properly?	▼
Why does the screen look yellow?	▼
Why can't I see the OSD Menu? And why aren't the controls accessible?	▼
What should I do if the Control Panel Keys aren't working?	▼
Why are some menus not selectable in the OSD Menu?	▼
Why is there no audio output?	▼
Why won't the connected USB devices work?	▼

Maintaining the Monitor

General Precautions

- Make sure the monitor is turned off and the power cable is unplugged from the power outlet.
- Never spray or pour any liquid directly onto the screen or case.
- Handle the monitor with care, as a darker-colored monitor, if scuffed, may show marks more clearly than a lighter-colored monitor.

Cleaning the Screen

- Wipe the screen with a clean, soft, lint-free cloth. This removes dust and other particles.
- If the screen is still not clean, apply a small amount of non-ammonia, non-alcohol based glass cleaner onto a clean, soft, lint-free cloth; then wipe the screen.

Cleaning the Case

- Use a soft, dry cloth.
- If the case is still not clean, apply a small amount of non-ammonia, non-alcohol based, mild non-abrasive detergent onto a clean, soft, lint-free cloth, then wipe the surface.

Disclaimer

- ViewSonic® does not recommend the use of any ammonia or alcohol-based cleaners on the display screen or case. Some chemical cleaners have been reported to damage the screen and/or case of the monitor.
- ViewSonic® will not be liable for damage resulting from use of any ammonia or alcohol-based cleaners.

Retrieved from "https://manuals.viewsonic.com/index.php?title=VX2428_Full_Guide&oldid=28443 <
https://manuals.viewsonic.com/index.php?title=VX2428_Full_Guide&oldid=28443> "