

MOUNT-IT!

Installation Manual

MI-3882WHT

MI-3882BLK

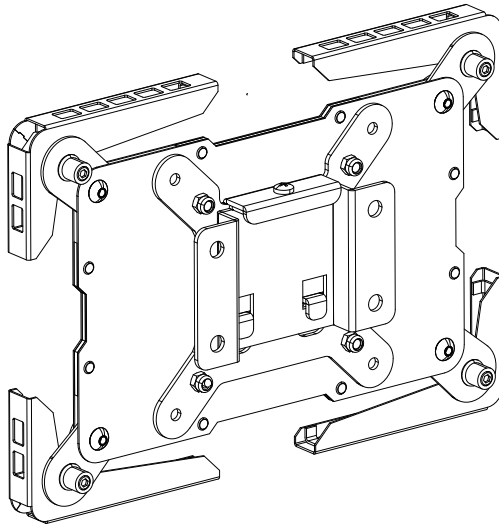

UNIVERSAL TABLET WALL MOUNT



HAVE QUESTIONS?

Monday - Friday from 8:00am - 4:00pm PST



support@mount-it.com



(855) 925-5668



www.mount-it.com

Thank you for choosing Mount-It!

EN  Read the entire instruction manual before you start installation and assembly. If you have any questions regarding any of the instructions or warnings, please contact Mount-It! for assistance.



CAUTION: Use with products heavier than the rated weights indicated may result in instability causing possible injury.

• Please closely follow the assembly instructions. Improper installation may result in damage or serious personal injury.

- Safety gear and proper tools must be used. This product should only be installed by professionals.
- This product is designed to be installed on solid concrete walls, masonry walls or wood stud walls.
- Make sure that the supporting surface will safely support the combined weight of the equipment and all attached hardware and components.

• Use the mounting screws provided and DO NOT OVER TIGHTEN mounting screws.

• This product contains small items that could be a choking hazard if swallowed. Keep these items away from children.

• This product is intended for indoor use only. Using this product outdoors could lead to product failure and personal injury.

IMPORTANT: Ensure that you have received all parts according to the component checklist prior to installation. If any parts are missing or faulty, contact Mount-It! for a replacement.

MAINTENANCE: Check that the product is secure and safe to use at regular intervals (at least every three months).

DE  Lesen Sie die gesamte Bedienungsanleitung, bevor Sie mit der Installation und Montage beginnen. Wenn Sie Fragen zur Anleitung oder Warnungen haben, wenden Sie sich bitte an Ihren örtlichen Händler.



VORSICHT: Die Verwendung mit Produkten, die schwerer als die angegebenen Nenngewichte sind, kann zu Instabilität führen und zu möglichen Verletzungen führen.

- Bitte befolgen Sie die Montageanleitung genau. Eine unsachgemäße Installation kann zu Schäden oder schweren Verletzungen führen.
- Sicherheitsausrüstung und geeignete Werkzeuge müssen verwendet werden. Dieses Produkt sollte nur von Fachleuten installiert werden.

• Dieses Produkt ist auf massiven Betonwänden oder Mauerwerkswänden zu montieren.

• Stellen Sie sicher, dass die Auflagefläche das Gesamtgewicht des Geräts und aller angeschlossenen Hardware und Komponenten sicher trägt.

• Verwenden Sie die mitgelieferten Befestigungsschrauben und die Befestigungsschrauben NICHT ZU FEST ANZIEHEN.

• Dieses Produkt enthält Kleinteile, die beim Verschlucken eine Erstickengefahr darstellen können. Halten Sie diese Gegenstände von Kindern fern.

• Dieses Produkt ist nur für den Innenbereich bestimmt. Die Verwendung dieses Produkts im Freien kann zu Produktversagen und Verletzungen führen.

WICHTIG: Stellen Sie vor der Installation sicher, dass Sie alle Teile gemäß der Komponenten-Checkliste erhalten haben. Bei beschädigten oder fehlenden Teilen,

wenden Sie sich an Ihre Verkaufsstelle, um Ersatz zu erhalten.

WARTUNG: Überprüfen Sie das Produkt in regelmäßigen Abständen auf Sicherheit und Stabilität (am besten alle drei Monate).

FR  Lisez entièrement le guide d'utilisateur avant de commencer l'installation et le montage. Si vous avez des questions concernant les instructions ou les avertissements, veuillez contacter votre distributeur local pour une assistance.



ATTENTION: L'utilisation de produits plus lourds que les poids nominaux indiqués peut entraîner une instabilité causant des blessures potentielles.

• Les supports doivent être joints comme spécifié dans les instructions de montage. Une mauvaise installation peut entraîner des dommages ou de graves blessures aux personnes.

• Un équipement de sécurité et les outils appropriés doivent être utilisés. Ce produit devrait être installé uniquement par des professionnels.

• Ce produit est conçu pour être installé sur des murs avec poteaux en bois, des murs en béton massif ou murs en brique.

• Assurez-vous que la surface de soutien sur laquelle le produit est installé est solide et composée de matériaux et composants associés.

• Utilisez les vis de montage fournies et NE SERREZ PAS TROP les vis de montage.

• Ce produit contient de petites pièces qui peuvent causer un étouffement si elles sont avalées. Éloignez ces pièces des enfants.

• Ce produit est prévu uniquement pour une utilisation à l'intérieur. L'utilisation de ce produit à l'extérieur peut entraîner une défaillance du produit ou des blessures aux personnes.

IMPORTANT: Avant l'installation, assurez-vous que vous avez reçu toutes les pièces selon la liste de vérification des composants. Si une pièce est manquante ou endommagée, téléphonez à votre distributeur local pour qu'il la remplace.

MAINTENANCE: A intervalles réguliers (au moins tous les trois mois) vérifiez que le support est d'utilisation sûre et fiable.

RU  Перед началом установки и сборки прочитайте руководство по установке. Если у Вас возникли какие-либо вопросы относительно инструкций или предупреждений, свяжитесь с Вашим местным распространителем для получения помощи.



Внимание: Использование продуктов, вес которых превышает указанный расчетный вес, может привести к неустойчивости и возможным травмам.

• Опоры должны быть установлены, как это показано в монтажных инструкциях. Неправильная установка может привести к получению серьезных травм.

• Необходимо использовать предохранительное устройство и специальные инструменты. Продукт должен устанавливаться только профессионалами.

• Продукт предназначен для установки на деревянные каркасные стены, твердые цементные стены или кирпичные стены.

• Убедитесь, что несущая поверхность выдержит вес всего установленного оборудования и комплектующих.

• Необходимо использовать монтажные винты, входящие в комплект поставки, и НЕ ПЕРЕТЯГИВАТЬ монтажные винты.

• Данный продукт содержит мелкие детали, которые представляют опасность удушья при проглатывании. Такие детали необходимо хранить в недоступном для детей месте.

• Данный продукт предназначен только для эксплуатации в помещении. Использование данного продукта на улице может привести к поломке продукта и получению травм.

ВАЖНО: Перед установкой убедитесь, что Вы получили все детали в соответствии со списком комплектующих. Если не хватает каких-либо деталей или они поломаны, свяжитесь с Вашим местным распространителем по вопросу замены.

ТЕХНИЧЕСКОЕ ОБСЛУЖИВАНИЕ: Необходимо регулярно проверять (как минимум, раз в три месяца), чтобы крепежные болты зафиксированы, и его использование было безопасным.

ES  Lea todo el manual de instrucciones antes de comenzar la instalación y ensamble de la unidad. Si tiene alguna inquietud con respecto a las instrucciones o advertencias, comuníquese con su distribuidor local.



PRECAUCIÓN: utilizar con productos de mayor peso al indicado en los límites de peso podría ocasionar inestabilidad y posibles heridas personales.

• Los soportes deben acoplarse tal como se indica en las instrucciones de ensamble. Una incorrecta instalación podría ocasionar daños y serias heridas personales.

• Utilice las herramientas y equipo de seguridad adecuados. Este producto solo debe ser instalado por profesionales.

• Este producto está diseñado para instalaciones en paredes de madera sólida, concreto sólido o bloques.

• Asegúrese de que la superficie de fijación sostenga de manera segura el peso total del equipo y todos sus componentes y hardware.

• Utilice los tornillos de ensamble suministrados y NO aplique demasiada tensión a los tornillos.

• Este producto contiene piezas pequeñas que representan un riesgo de asfixia. Mantenga estas piezas fuera del alcance de los niños.

• Este producto está diseñado para uso en interiores solamente. Utilizar este producto en exteriores podría ocasionar fallas y heridas personales.

IMPORTANTE: Asegúrese de que haya recibido todas las piezas según la lista de verificación de componentes para la instalación. Si falta alguna de las partes, o está dañada, comuníquese con su distribuidor.

MANTENIMIENTO: Compruebe periódicamente que el soporte esté asegurado y listo para usar (al menos cada tres meses).

PT  Leia todo o manual de instruções antes de iniciar a instalação e montagem. Se você tiver alguma dúvida sobre qualquer uma das instruções ou avisos, por favor, entre em contato com o seu distribuidor local para assistência.



ATENÇÃO: O uso com produtos mais pesados do que os pesos indicados pode resultar em instabilidade, causando possíveis danos.

• Os suportes devem ser anexados como especificado nas instruções de montagem. A instalação incorreta pode causar danos ou sérias lesões pessoais.

• Equipamentos de segurança e ferramentas adequadas devem ser utilizadas. Este produto só deve ser instalado por profissionais.

• Este produto é projetado para ser instalado em pilares verticais de paredes de madeira, paredes de concreto sólido ou de tijolos.

• Certifique-se que a superfície de suporte suportará com segurança o peso combinado do equipamento e todos as ferragens e componentes anexados.

• Use os parafusos de montagem fornecidos e NÃO APERTÉ EXCESSIVAMENTE os mesmos.

• Este produto contém pequenas peças que podem causar asfixia se ingeridas. Mantenha essas peças longe do alcance de crianças.

• Este produto destina-se somente para uso interno. Usá-lo em ambiente externo pode causar falhas no produto e lesões pessoais.

IMPORTANTE: Assegure-se que você recebeu todas as peças, de acordo com a lista de componentes, antes da instalação. Se alguma peça estiver faltando ou é defeituosa, contate o seu distribuidor local para substituição.

MANUTENÇÃO: Certifique-se que o suporte seja seguro e protegido para o uso em intervalos regulares (pelo menos a cada três meses).

Mount and Accessories

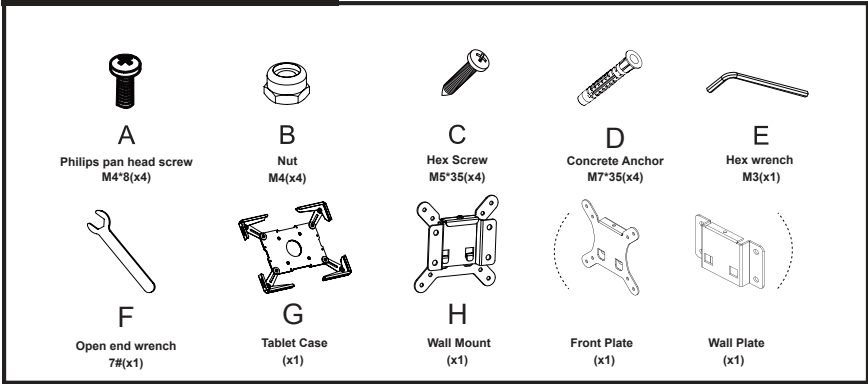

Check carefully to make sure there are no missing or defective parts. Some hardware provided may not be used. Use the correct mounting hardware suitable for your installation.

CHOKING HAZARD. Package includes small parts.
Not for children under 3 years. Adult supervision is required.

Missing Parts? Call us at (855) 925-5668 and we will ship replacement parts free of charge.

DIMENSIONS & WEIGHT CAPACITY

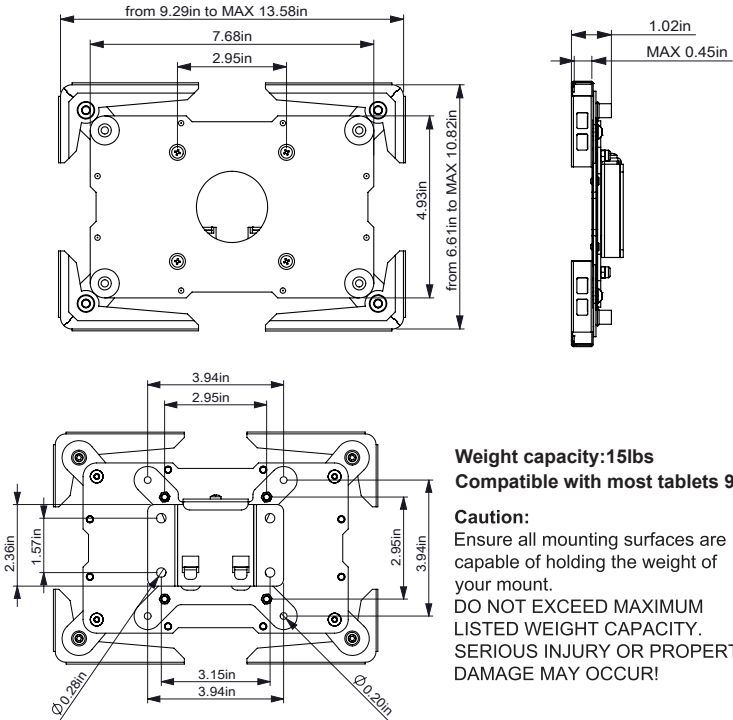

Step 1

Drill Pilot Holes

Concrete/Stone Installation Only:

Wood Stud walls can be installed to without pilot holes.

- Using a bubble level to ensure a straight installation, hold the Wall Mount (#H) against the wall in the desired location and use a pencil to mark the wall through the 4 bolt holes.
- Remove the mount from the wall and drill holes in the marked locations using a 1/16" (7mm) drill bit to a depth of 1.38" (35mm).

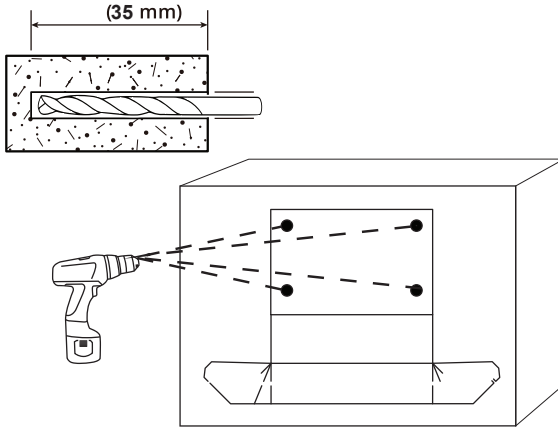

Step 2

Mount the Wall Plate

- Unscrew the bolt on the top of the Wall Mount (#H) and separate the two parts.
- Insert the Concrete Anchors (#D) into the drilled holes then attach the Wall Plate to the wall in the orientation shown here using the Bolts (#C).

Note: For drywall installation ensure that either the left or right screws are installed into a wall stud. Do not use Concrete Anchors (#D) for drywall installation.

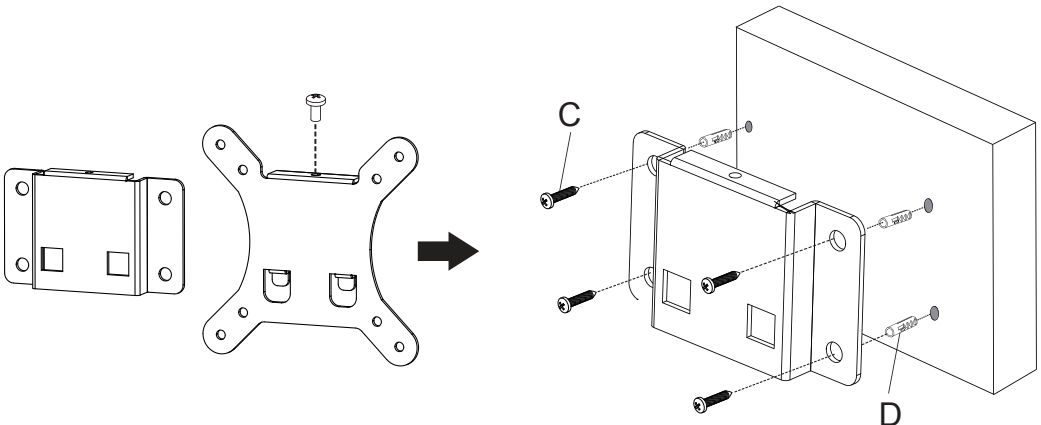

Step 3

Attach the Tablet Case to the Front Plate

- Choose the desired orientation between landscape and portrait. The image below shows landscape orientation, for portrait rotate the tablet case 90°.
- Attach the Tablet Case (#G) to the Front Plate using the Bolts (#A) through the front of the case and secured on the opposite side using the Nuts (#B). Tighten until secure using the Wrench (#F).

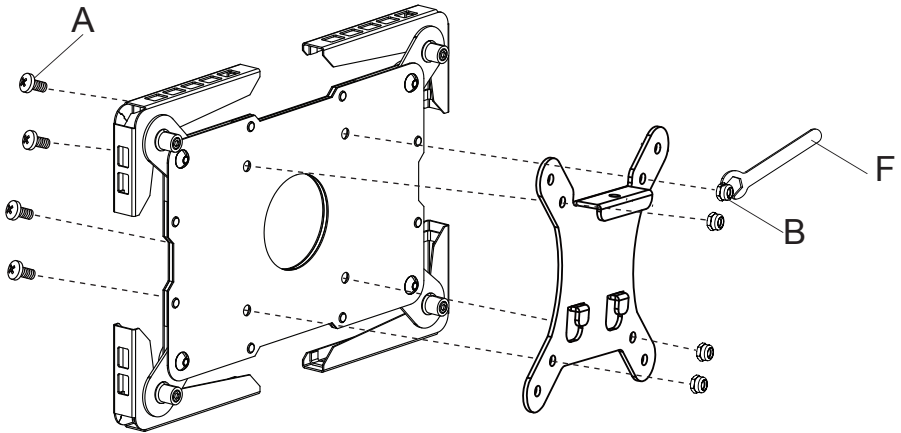

Step 4

Insert the tablet

- Loosen the bolts on the back of the tablet case using Hex Wrench (#E) and expand the case to a size larger than that of the tablet. Insert the tablet and slide the sides of the case in until all 4 corners are snug against the tablet, then tighten the bolts back down once more to secure the tablet in the case.

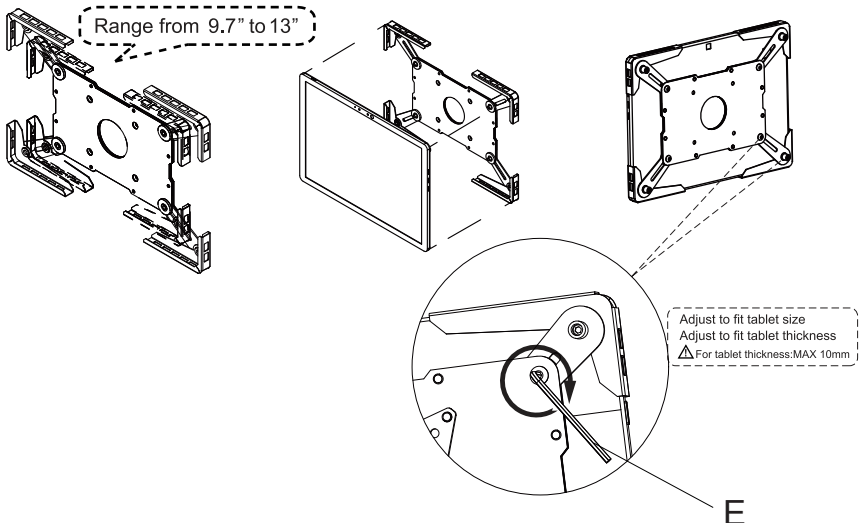

Step 5

Hang the Tablet Case on the Wall Plate

- Hang the Tablet Case on the Wall Plate ensuring that the hooks are fully seated in the holes as shown in the magnification bubble.

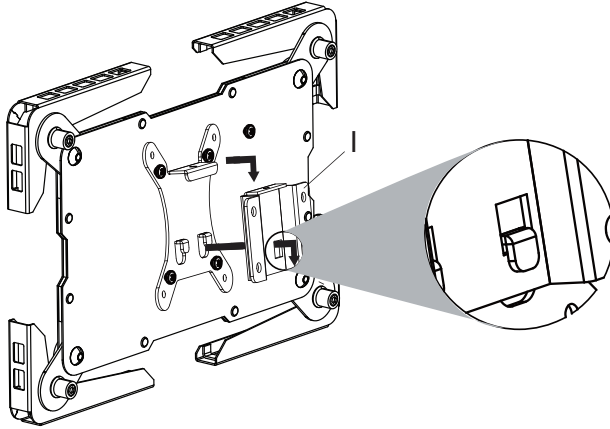

Step 6

Secure the Mount

- Reinstall the Bolt to the top of the Wall Mount to prevent the tablet from being lifted off the bracket.

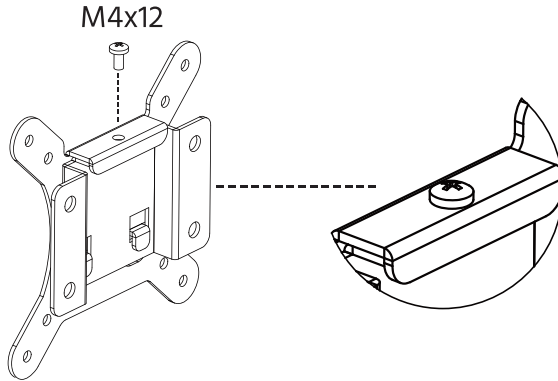

Visit us at www.mount-it.com for product registration and warranty information.

Our US based customer service team is standing by to answer any questions you have about your Mount-It! product.

Available by phone **Monday - Friday from 8:00am to 4:00pm PST.**

Chat live with an agent on our website!



support@mount-it.com



(855) 925-5668



www.mount-it.com