



User Manual

AVoIP controller for JP4K3K and JP4K6K

**AVoIP
JPEG2000**

Product no:
VLIP-JP1G-CTRL

Welcome, to the VigilLink User Manual!

Thank you for your purchase. At VigilLink, we prioritize the end-user experience by focusing on ease of use, ensuring our solutions are straightforward to install and program for our valued dealers. Our mission goes beyond product development; we aim to create a seamless experience for both integrators and end-users.

We value your feedback and would love to hear about your experience. Positive feedback reassures us that we have achieved our goals. If there are any areas where we have not met your expectations, we encourage you to reach out and share your thoughts so we can understand your experience and work to exceed your expectations in the future.

Thank you again for your purchase, and we look forward to hearing from you!

Mickey Park

Founder and CEO, VigilLink



Connecting for a Smarter Future

Surge protection device recommended

This product includes sensitive electrical components that can be damaged by electrical spike, surges, shocks, or lightning strikes. To safeguard and prolong the lifespan of your equipment, it is highly recommended to use surge protection systems.

Caution

The product requires the use of UTP connectors. Please connect in direct interconnection method and do not cross connect.

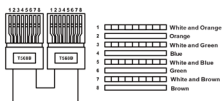

Direct Interconnection Method

Copyright

© 2024 VigilLink. All right reserved. www.vigilink.com



Connecting for a Smarter Future

Table of Contents:

1.	Product Description -----	6
2.	Featured Highlights -----	7
3.	Included Components -----	8
4.	Specifications	9
5.	Operation Control and Functions	
	01. Front Panel -----	10
	02. IR Pin Definition-----	11
6.	Rack Mounting Instructions	
	01. 6U V2 Rack Mounting -----	12
	02. 1U V2 Rack Mounting -----	13
7.	Web GUI User Guide	
	01. Preparation before Entering the System -----	15
	02. Functions and Operations -----	24
3.	Application Example -----	52

1. Product Description

VigilLink's Video over IP Controller is used to control and manage JPEG2000 IP products. It supports dual 100M network ports, which can realize dual-network isolation of Control network and Multicast video distribution network. Built-in Web GUI, TCP and RS-232 control are supported. It supports POE function and wide-band 12V IR signal receiving. Since the demand of IP products is daily increased in the current market, the IP Controller will be widely applied in more and more different scenarios.



Connecting for a Smarter Future

2. Featured Highlights

- Easy to create project, control and manage the system
- Flexibly support Auto, DHCP and Manual three types of IP configurations
- HTTPS, SSH, SFTP security compatible
- Built-in Web GUI control interface, supporting Drag & Drop operations
- Support image preview
- Support video, audio, RS-232, IR, KVM, CEC control and management of the distributed system
- Dual network ports (VIDEO LAN port supports POE function) to isolate Controls and Multicast networks.
- Support LAN/RS-232 port control and third-party central control
- Support IR signal receiving (3.5mm audio jack, 12V level)
- 4 channel GPIO control ports (5V/12V optional level)
- Multiple circuits protection, lightning protection and ESD design
- Reliable system design, ensuring 24/7 stable usage

3. Included Components

Encoder or Decoder	
Qty	Component
1	Video over IP Controller
1	20kHz-60kHz 12V IR Receiver Cable (1.5 meters)
1	3-pin 3.81mm Phoenix Connector (Male)
1	6-pin 3.81mm Phoenix Connector (Male)
1	12V/2.5A locking power adapter
2	Mounting ear
4	Machine screw (KM3*4)
1	User manual



Connecting for a Smarter Future

4. Specifications

Network Bandwidth	100M
Transmission Distance	100M CAT5E/6/6A/7
Control Ports	2 x 100M LAN [RJ45 connector] [VIDEO LAN support POE] 1 x IR IN [3.5mm audio jack, 12V level] 1 x DIGITAL I/O [6-pin 3.81mm phoenix connector] 1 x RS-232 [3-pin 3.81mm phoenix connector]
Dimensions	8.03 inches (204mm) [W] × 3.88 inches (98.5mm) [D] × 0.85 inches (21.5mm) [H]
Housing	Metal Enclosure
Color	Black
Weight	1.12 LBS (509g)
Power Supply	12V/1A
Power Consumption	4.5W
Operating Temperature	0°C ~ 40°C / 32°F ~ 104°F
Storage Temperature	-20°C ~ 60°C / -4°F ~ 140°F
Relative Humidity	20~90% RH (non-condensing)

5. OPERATIAON CONTROLS AND FUNCTIONS

5.1 FRONT PANEL

FRONT

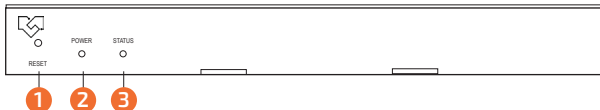

NO	NAME	FUNCTION DESCRIPTION
1	RESET BUTTON	Press and hold this button (about 10 seconds) until Status LED starts flashing, Controller will be reset automatically
2	POWER LED	The red LED will light on when the Controller is powered on.
3	STATUS LED	The status LED will flash in yellowish-green every 1 second until Controller boots up completely and Control LAN is ready, then it becomes solid.

5.2 FRONT PANEL

BACK

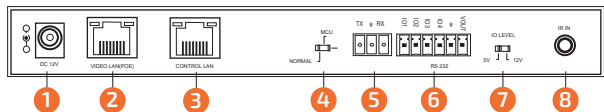

NO	NAME	FUNCTION DESCRIPTION
1	DC 12V	DC 12V/1A power input port.
2	VIDEO LAN (POE)	100M Video LAN port, supporting POE function. <i>Note: When POE is enabled, DC 12V/1A power supply is not required.</i>

NO	NAME	FUNCTION DESCRIPTION
3	CONTROL LAN	The TCP/IP control network port.
4	MCU/Normal DIP Switch	Normal mode (Default): The RS-232 port is used for serial port commands control. MCU mode: The RS-232 port is used for MCU software upgrade.
5	3-pin Phoenix Connector	RS-232 serial communication port.
6	6-pin Phoenix Connector	4 channel I/O level outputs, 1 channel grounding, 1 channel power supply to the outside.
7	IO LEVEL DIP Switch	Used to control I/O level output and VOUT voltage. Switch to left: 5V I/O level output, VOUT is 5V. Switch to right: 12V I/O level output, VOUT is 12V.
8	IR IN	12V IR signal input port.

5.3 IR Pin Definition



IR Receiver

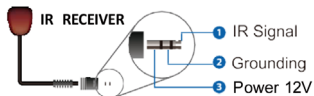

Connecting for a Smarter Future

6. Rack Mounting Instruction

6.1 6U V2 Rack Mounting

This Controller can be mounted in a standard 6U rack (Please contact your supplier for 6U rack sale). The mounting steps are as follows:

Step 1: Use included screws to fix two mounting ears on the Controller, as shown in the figure below:

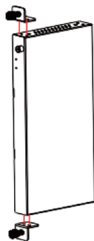

Step 2: Insert the Controller with mounting ears into a 6U rack (up to 10 units can be installed vertically), as shown in the figure below:

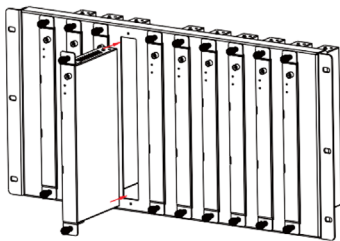

Connecting for a Smarter Future

Step 3: Use screws to fix mounting ears on the rack to complete the mounting, as shown in the figure below:

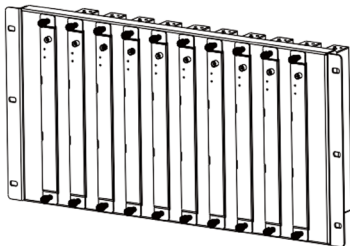

6.2 1U V2 Rack Mounting

This Controller also can be mounted in a standard 1U rack (up to 4 units can be installed horizontally).

The mounting steps are as follows:

Step 1: Stack two Controllers on top of each other, then use included screws to fix two 1U rack panels on the Controllers, as shown in the figure below:



Step 2: Fix two 1U rack panels on another two stacked Controllers in the same way, then use screws to fix two 1U rack panels together, as shown in the figure below:

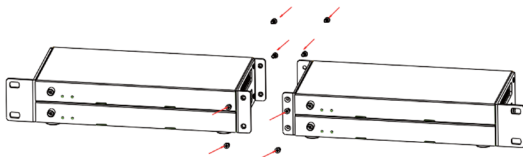

Step 3: Fasten screws between two 1U rack panels, so that four Controllers are mounted in a 1U rack, as shown in the figure below:



7. Web GUI User Guide

7.1 Preparation before Entering the System

You can use Controller's Web GUI to control all IP products at the Switch. The operation method is shown as below:

Step 1: Input the Controller's default IP address (Control LAN port: 192.168.6.100; Video LAN port: 169.254.8.100) or the URL (<http://controller.local>) into the Web browser address bar on the PC to enter the Web GUI login interface.



When logging in for the first time, please select the initial username (admin), input the initial password (admin), and select the desired language on the above login interface. Then click "Login" to enter the password modification interface, as shown below.

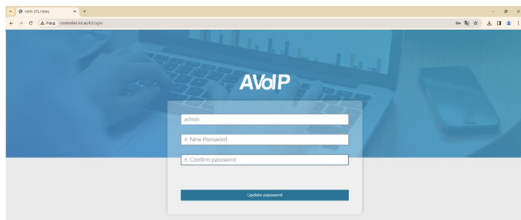

Please set a six-digit password using letters or numbers, then use the new password to login the Web GUI.

For the initial setup, please follow the steps shown in the figure below:

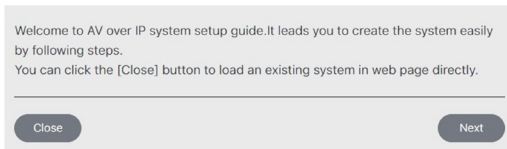

Step 2: Click the “Close” button to load an existing system in web page directly, or click “Next” button to go to the next step.

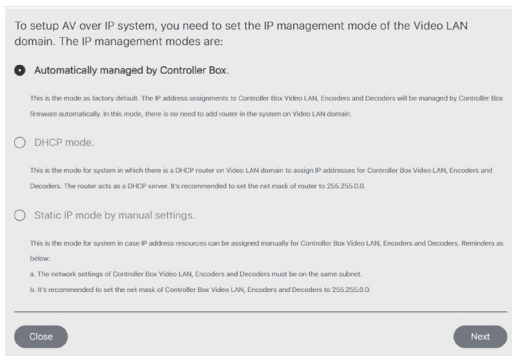

Connecting for a Smarter Future

On this interface, you need to set the IP mode of Video LAN.
Mode 1: Automatically managed by Controller Box.
The IP addresses of the Video LAN port, Encoder and Decoder are assigned by the Controller automatically, and the connection method is as following.

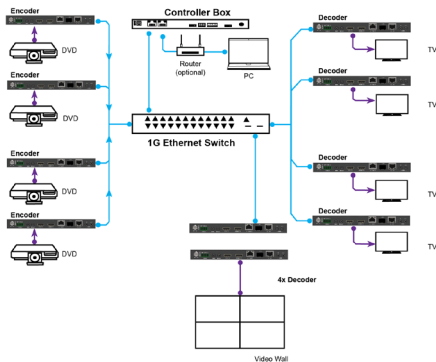

Step 3: Click the “Next” button and wait for the completion to enter the interface as shown in the figure below.

Now you can select to automatically add all following discovered Encoders and Decoders to system or just list them in the web page and you can add each of them to system manually.

Please click the [Search] button to search Encoders and Decoders in the system:

Automatically add Encoders and Decoders to system.

List all discovered Encoders and Decoders.

Close Next

- If you select “Automatically add Encoders and Decoders to system”, and click the “Next” button to enter the Device page, the system starts to search for devices. All the connected devices will be searched and added into the system (presented in the Encoder/Decoder list) automatically, as shown below.

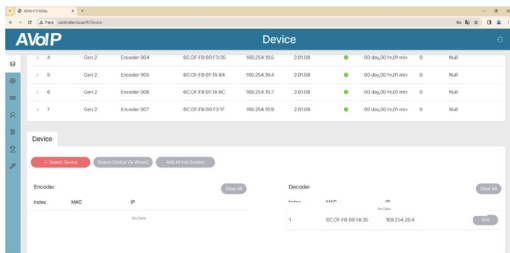

- If you select “List all discovered Encoders and Decoders”, and click the “Next” button to enter the Device page, the system starts to search for devices. All the connected devices will be searched and listed in the Device list. Click “Search Device” to stop search, then an inquiry box will pop up. If selecting “Yes”, all searched devices will be added into the system directly; If selecting “No”, you need to manually add them into the system by clicking the “Add” button behind each device one by one or clicking “Add All Into System”.



Now you can select to automatically add all following discovered Encoders and Decoders to system or just list them in the web page and you can add each of them to system manually.

Please click the [Search] button to search Encoders and Decoders in the system:

- Automatically add Encoders and Decoders to system.
- List all discovered Encoders and Decoders.

Close

Next

The screenshot shows the AvVoIP web interface. At the top, there's a 'Device' header. Below it, there are search buttons: 'Search Device', 'Search Device Via Wizard', and 'Add'. A table lists discovered devices with columns for Index, MAC, IP, and a 'Add' button. A dialog box titled 'Auto Assign system' is overlaid on the table, asking if all 27 devices (10 Encoders and 17 Decoders) should be added to the system. The dialog has 'No' and 'Yes' buttons.

Index	MAC	IP	Add
1	8C:DF:F8:00:87:69	192.254.10.1	Add
2	8C:DF:F8:00:87:67	192.254.10.2	Add
3	8C:DF:F8:00:87:68	192.254.10.3	Add
4	8C:DF:F8:00:87:26	192.254.10.5	Add
5	8C:DF:F8:01:5A:84	192.254.10.4	Add
6	8C:DF:F8:01:5A:8C	192.254.10.7	Add

If you want to change the IP mode of Video LAN, you can click “Search Device Via Wizard” on the Device interface, and switch back to the IP mode select interface.

Mode 2: DHCP mode.

The IP addresses of the Video LAN port, Encoder and Decoder are assigned by the Router automatically, and the connection method is as following.

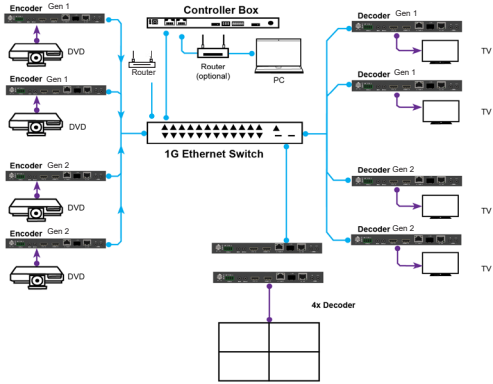

Connecting for a Smarter Future

Select “DHCP Mode” on the interface shown below, and click “Next”.

To setup AV over IP system, you need to set the IP management mode of the Video LAN domain. The IP management modes are:

Automatically managed by Controller Box.

This is the mode as factory default. The IP address assignments to Controller Box Video LAN, Encoders and Decoders will be managed by Controller Box firmware automatically. In this mode, there is no need to add router in the system on Video LAN domain.

DHCP mode.

This is the mode for system in which there is a DHCP router on Video LAN domain to assign IP addresses for Controller Box Video LAN, Encoders and Decoders. The router acts as a DHCP server. It's recommended to set the net mask of router to 255.255.0.0.

Static IP mode by manual settings.

This is the mode for system in case IP address resources can be assigned manually for Controller Box Video LAN, Encoders and Decoders. Reminders as below:

- The network settings of Controller Box Video LAN, Encoders and Decoders must be on the same subnet.
- It's recommended to set the net mask of Controller Box Video LAN, Encoders and Decoders to 255.255.0.0.

The rest of the steps are the same as the Mode 1 operation.

Mode 3: Static IP mode by manual settings.

The IP addresses of the Video LAN port, Encoder and Decoder are manually set by the user, and the connection method is as following.

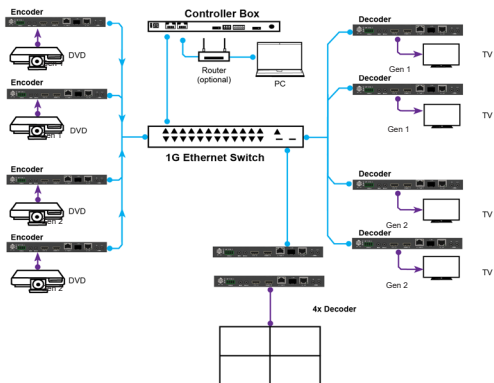

Select “Static IP mode by manual settings” on the interface shown below, and click “Next”.

To setup AV over IP system, you need to set the IP management mode of the Video LAN domain. The IP management modes are:

Automatically managed by Controller Box.

This is the mode as factory default. The IP address assignments to Controller Box Video LAN, Encoders and Decoders will be managed by Controller Box firmware automatically. In this mode, there is no need to add router in the system on Video LAN domain.

DHCP mode.

This is the mode for system in which there is a DHCP router on Video LAN domain to assign IP addresses for Controller Box Video LAN, Encoders and Decoders. The router acts as a DHCP server. It's recommended to set the net mask of router to 255.255.0.0.

Static IP mode by manual settings.

This is the mode for system in case IP address resources can be assigned manually for Controller Box Video LAN, Encoders and Decoders. Reminders as below:

- The network settings of Controller Box Video LAN, Encoders and Decoders must be on the same subnet.
- It's recommended to set the net mask of Controller Box Video LAN, Encoders and Decoders to 255.255.0.0.

Close Next



Connecting for a Smarter Future

After entering the interface shown in the figure below, manually set the IP address, subnet mask and gateway of the Video LAN.

Encoders and Decoders IP Addresses Range Settings:

Encoders IP Address From To

Decoders IP Address From To

Reminder:

To easily manage the IP addresses of Encoders and Decoders, it's strongly recommended that you can set the IP addresses of Encoders and Decoders to different segments correspondingly. For example:

Encoders IP address from 169.254.10.1 to 169.254.12.255
Decoders IP address from 169.254.20.1 to 169.254.22.255

On this interface, you can set the IP address range of Encoders and Decoders.

After the setting is complete, click the “Next” button to enter the interface as shown in the figure below.

Now you can select to automatically add all following discovered Encoders and Decoders to system or just list them in the web page and you can add each of them to system manually.

Please click the [Search] button to search Encoders and Decoders in the system:

Automatically add Encoders and Decoders to system.

List all discovered Encoders and Decoders.

The rest of the steps are the same as the Mode 1 operation.

7.2 Functions and Operations

■ Device Page

On this page, you can click the Encoder/Decoder tab to check the information of the Encoders and Decoders in the system, such as ID, Type, Name, MAC address, IP address, Firmware version, Online/Offline Status, Up Time, RX Link, Member/Source. Besides, you can configure each Encoder/Decoder

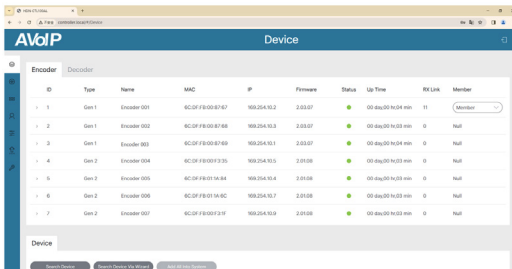

The screenshot shows the AVoIP Device page with a table of encoders. The table has columns for ID, Type, Name, MAC, IP, Firmware, Status, Up Time, RX Link, and Member. There are 7 rows of encoder data.

ID	Type	Name	MAC	IP	Firmware	Status	Up Time	RX Link	Member
1	Gen 1	Encoder 001	6C:DF:F8:00:87:67	192.254.10.2	2.03.07	Online	00 day:00 hr:04 min	11	Member
2	Gen 1	Encoder 002	6C:DF:F8:00:87:66	192.254.10.3	2.03.07	Online	00 day:00 hr:03 min	0	Null
3	Gen 1	Encoder 003	6C:DF:F8:00:87:69	192.254.10.1	2.03.07	Online	00 day:00 hr:04 min	0	Null
4	Gen 2	Encoder 004	6C:DF:F8:00:F3:35	192.254.10.5	2.01.08	Online	00 day:00 hr:03 min	0	Null
5	Gen 2	Encoder 005	6C:DF:F8:01:1A:84	192.254.10.4	2.01.08	Online	00 day:00 hr:03 min	0	Null
6	Gen 2	Encoder 006	6C:DF:F8:01:1A:8C	192.254.10.7	2.01.08	Online	00 day:00 hr:03 min	0	Null
7	Gen 2	Encoder 007	6C:DF:F8:00:F3:3F	192.254.10.6	2.01.08	Online	00 day:00 hr:03 min	0	Null

Note: The controller can simultaneously control two types of Encoders and Decoders (distinguished by Gen 1/2) in one system.

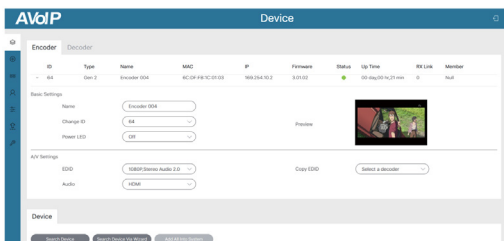

The screenshot shows the configuration page for Encoder 004. It includes fields for Name, Change ID, Power LED, EDD, and Audio, along with a preview image and a 'Select a decoder' button.

ID	Type	Name	MAC	IP	Firmware	Status	Up Time	RX Link	Member
04	Gen 2	Encoder 004	6C:DF:F8:1C:01:03	192.254.10.2	3.01.02	Online	00 day:00 hr:21 min	0	Null

Basic Settings

- Name: Encoder 004
- Change ID: 04
- Power LED: Off

AV Settings

- EDD: SBRP (Stereo Audio 2.0)
- Audio: HDMI

Device



Connecting for a Smarter Future

Encoder Configuration Basic Settings

- 1. Name:** The name of the Encoder can be changed. (The maximum length is 16 characters. Special characters are not supported.)
- 2. Change ID:** The ID of the Encoder can be set. (ID range: 1-762)
3. Note: Both ID and name can not be duplicated.
- 4. Power LED:** Click the drop-down menu to select the power LED flash status.
- 5. On:** The front panel power LED flashes.
- 6. On 90s:** The front panel power LED is steady on after flashing for 90s.
- 7. Off:** The front panel power LED is steady on after flash status is turned off.
- 8. Preview:** The preview of the Encoder.

A/V Settings

- 1. EDID:** Click the drop-down menu to select the EDID for the Encoder.
- 2. Copy EDID:** Click the drop-down menu to select a Decoder for EDID copy.
- 3. Audio:** Click the drop-down menu to select the audio source (HDMI/ Analogue).
(1)When HDMI is selected, Encoder HDMI input is the audio source for Encoder HDMI output and Decoder audio output.
(2) When Analogue is selected, Encoder audio input is the

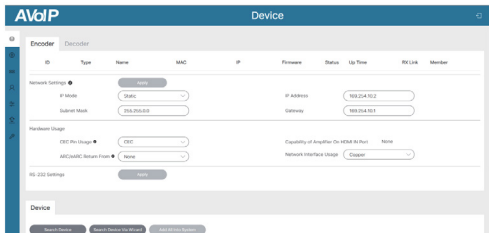

audio source for Encoder HDMI output and Decoder audio output.

Network Settings

- 1. IP Mode:** Click the drop-down menu to set the IP mode (Static/DHCP).
- 2. IP Address:** The IP address of the Encoder.
- 3. Subnet Mask:** The Subnet Mask of the Encoder.
- 4. Gateway:** The Gateway of the Encoder

Note:

- (1) If the IP mode is set to "Static", you can manually set the IP Address, Subnet Mask and Gateway as required. Then click "Apply", the Encoder will immediately reboot to take effect.*
- (2) If the IP mode is set to "DHCP", it will search and be filled with the IP Address assigned by the router automatically.*
- (3) If the Encoder is actually alive in the system but with incorrect network segment settings, even though the Encoder is offline, its network settings including IP address can be changed and set.*



Connecting for a Smarter Future

Hardware Usage

1. CEC Pin Usage: Click the drop-down menu to set the CEC pin usage (ARC/eARC/CEC/Off). After switching, the Encoder will immediately reboot to take effect.

2. ARC/eARC Return From: Click the drop-down menu to select a Decoder for ARC/eARC audio return.

Note: Only Encoders with ARC/eARC function can perform this setting.

3. Capability of Amplifier On HDMI IN Port: It indicates the ARC capability supported by the Amplifier.

Note:

When the amplifier on HDMI IN port only supports ARC, and the TV connected to the Decoder only supports eARC, the setting of “eARC Down grade To ARC” on the Decoder needs to set “On” to achieve the audio path working normally. The eARC downgrade of the Decoder will also apply onto all Encoders that select this Decoder.

4. Network Interface Usage: Click the drop-down menu to set the network port (Fiber/Copper).

Note: Only Encoders that integrate Copper and Fiber ports can perform this setting.



RS-232 Settings

- 1. RS-232 Command Relay:** Click the drop-down menu to select On/Off to turn on/off the RS-232 command relay function.
 - 2. Parity:** Click the drop-down menu to set the parity.
 - 3. Baud Rate:** Click the drop-down menu to set the baud rate.
 - 4. Data Bits:** Click the drop-down menu to set the data bits.
 - 5. Stop Bits:** Click the drop-down menu to set the stop bits.
- After setting, click “Apply” to take effect.

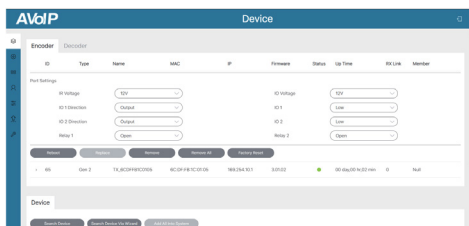

Port Settings

- 1. IR Voltage:** Click the drop-down menu to select the 5V/12V IR voltage.
- 2. IO Voltage:** Click the drop-down menu to select the 5V/12V IO voltage.
- 3. IO 1 Direction:** Click the drop-down menu to set the IO 1 direction (Input/ Output).
- 4. IO 1:** Click the drop-down menu to set the IO 1 level (Low/High).
- 5. IO 2 Direction:** Click the drop-down menu to set the IO 2 direction (Input/ Output).
- 6. IO 2:** Click the drop-down menu to set the IO 2 level (Low/High).
- 7. Relay 1:** Click the drop-down menu to select Open/Close Relay 1.
- 8. Relay 2:** Click the drop-down menu to select Open/Close Relay 2.



Reboot: Click the Reboot button to reboot the Encoder.

Replace: Click to replace the offline Encoder (which is in the system) with an online Encoder (which is not in the system).

For example, follow steps below to replace Encoder 001 with Encoder 006:

Step 1. Unplug the network cable of Encoder 001 to make it be offline. (Using external power supply.)

Step 2. Connect Encoder 006 to the system.

Step 3. Click the Replace button, which is clickable after Encoder 001 is set to be offline. Then a window will pop up, as shown below. At this moment, click “Scan for Devices” to search devices. After Encoder 006 is searched, select it and click “Replace” to replace Encoder 001.

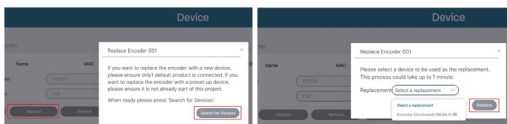

Remove: Click the Remove button to remove the Encoder from the system.

Remove All: Click this button to remove all Encoders from the system.

Factory Reset: Click this button to restore the Encoder to factory settings.

ID	Type	Name	MAC	IP	Firmware	Status	Up Time	Source
1	Gen1	Decoder 001	6C:DF:F9:00:14:46	193.254.20.5	2.03.07	Online	00 days,00 hr,14 min	Encoder 001
2	Gen1	Decoder 002	6C:DF:F9:00:14:3F	193.254.20.2	2.03.07	Online	00 days,00 hr,14 min	Encoder 001
3	Gen1	Decoder 003	6C:DF:F9:01:81:43	193.254.20.1	2.03.07	Online	00 days,00 hr,14 min	Encoder 001
4	Gen2	Decoder 004	6C:DF:F9:00:F3:3F	193.254.20.9	2.03.06	Online	00 days,00 hr,14 min	Encoder 001
5	Gen3	Decoder 005	6C:DF:F9:01:91:4C	193.254.20.7	2.03.06	Online	00 days,00 hr,15 min	Encoder 001
6	Gen3	Decoder 006	6C:DF:F9:01:9A:09	193.254.20.9	2.03.06	Online	00 days,00 hr,15 min	Encoder 001

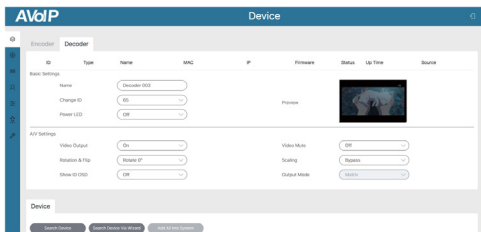

Decoder Configuration Basic Settings

1. Name: The name of the Decoder can be changed. (The maximum length is 16 characters. Special characters are not supported.)

2. Change ID: The ID of the Decoder can be set. (ID range:1-762)

Note: Both ID and name can not be duplicated.

3. Power LED: Click the drop-down menu to select the power LED flash status.

On: The front panel power LED flashes.

On 90s: The front panel power LED is steady on after flashing for 90s.

Off: The front panel power LED is steady on after flash status is turned off.

4. Preview: The preview of the Decoder.

Besides, you can click the drop-down menu of “Source” on the Decoder list to select signal source for the Decoder.

A/V Settings

1. Video Output: Click the drop-down menu to select On/Off to turn on/off the video output.



Connecting for a Smarter Future

- 2. Video Mute:** Click the drop-down menu to select On/Off to mute/unmute the video output.
- 3. Rotation & Flip:** Click the drop-down menu to select Rotate 0°/90°/180°/ 270° to rotate the image, or select Flip Horizontal/ Vertical to flip the image.
- 4. Scaling:** Click the drop-down menu to set the video output scaling resolution.
- 5. Show ID OSD:** Click the drop-down menu to select On/Off to turn on/off the ID OSD display.
- 6. Output Mode:** In the Video Wall mode, you can click the drop-down menu to select Matrix or Video Wall as the output mode. While, in the Matrix mode, this option cannot be selected.

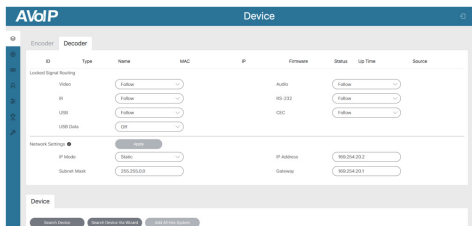

Locked Signal Routing

Different signals can be independently routed between Encoders and Decoders, including Video, Audio, IR, RS-232, USB and CEC; When clicking the drop-down menu and selecting "Follow", the corresponding signal comes from the current Encoder.

For example, follow steps below to change the video routing of Decoder 004 to be from Encoder 009.

Step 1. Click the drop-down menu of Video to select "Encoder 009".

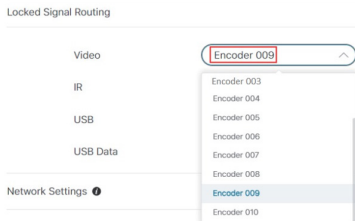

Step 2. Switch to the Matrix page and you will see a red frame on Decoder 004.

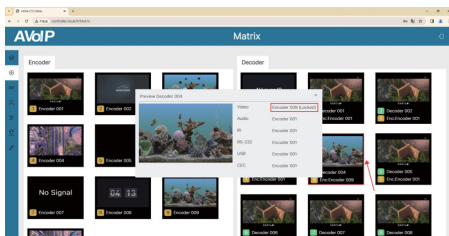

Step 3. Double-click the preview image of Decoder 004 to check the current settings. The video source has been locked to Encoder 009, while other signals still follow Encoder 001, as shown in the figure above.



Connecting for a Smarter Future

And you can change the source of audio, IR, RS-232, USB and CEC in the same way. In addition, you can click the drop-down menu of USB Data to select On/Off to turn on/off the USB data.



The screenshot shows a 'Network Settings' panel with an 'Apply' button at the top. Below the button are four input fields: 'IP Mode' is a dropdown menu currently set to 'Static'; 'Subnet Mask' is a text input field containing '255.255.0.0'; 'IP Address' is a text input field containing '192.254.20.2'; and 'Gateway' is a text input field containing '192.254.20.1'.

Network Settings

- 1. IP Mode:** Click the drop-down menu to set the IP mode (Static/DHCP).
- 2. IP Address:** The IP address of the Decoder.
- 3. Subnet Mask:** The Subnet Mask of the Decoder.
- 4. Gateway:** The Gateway of the Decoder.

Note:

- (1) If the IP mode is set to "Static", you can manually set the IP Address, Subnet Mask and Gateway as required. Then click "Apply", the Decoder will immediately reboot to take effect.*
- (2) If the IP mode is set to "DHCP", it will search and be filled with the IP Address assigned by the router automatically.*
- (3) If the Decoder is actually alive in the system but with incorrect network segment settings, even though the Decoder is offline, its network settings including IP address can be changed and set.*

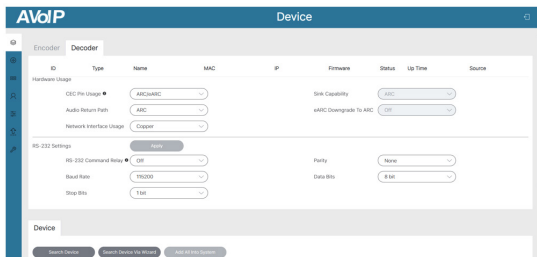

Hardware Usage

- 1. CEC Pin Usage:** Click the drop-down menu to set the CEC pin usage (ARC/eARC/CEC/Off). After switching, the Decoder will immediately reboot to take effect.
- 2. Sink Capability:** It indicates the ARC capability (eARC/ARC/None) supported by the TV.
- 3. Audio Return Path:** Click the drop-down menu to select the audio return path (ARC/S/PDIF).
- 4. eARC Downgrade To ARC:** When the amplifier on HDMI IN port only supports ARC, and the TV connected to the Decoder only supports eARC, the setting of “eARC Downgrade To ARC” needs to set “On” to achieve the audio path working normally. The eARC downgrade of the Decoder will also apply onto all Encoders that select this Decoder.

Note: The settings of “Sink Capability”, “Audio Return Path” and “eARC Downgrade To ARC” are available only for Decoders that support ARC/eARC.



Connecting for a Smarter Future

5. Network Interface Usage: Click the drop-down menu to set the network port (Fiber/Copper).

Note: Only Decoders that integrate Copper and Fiber ports can perform this setting.

RS-232 Settings

1. RS-232 Command Relay: Click the drop-down menu to select On/Off to turn on/off the RS-232 command relay function.

2. Parity: Click the drop-down menu to set the parity.

3. Baud Rate: Click the drop-down menu to set the baud rate.

4. Data Bits: Click the drop-down menu to set the data bits.

5. Stop Bits: Click the drop-down menu to set the stop bits.

After setting, click “Apply” to take effect.

The screenshot displays the AVoIP Device configuration page for a decoder. The interface includes a navigation sidebar on the left and a main content area. The main content area is divided into two sections: 'Part Settings' and a table of devices.

Part Settings:

ID Voltage	12V	ID Voltage	12V
ID 1 Direction	Output	ID 1	Low
ID 2 Direction	Input	ID 2	High
Relay 1	Open	Relay 2	Open

Buttons: Refresh, Settings, Remove ID, Factory Reset

Device Table:

ID	Type	Name	MAC	IP	Firmware	Status	Up Time	Source
66	Gen-2	Decoder 004	8C:DF:FB:7C:01:06	193.254.20.1	3.01.02	●	00 day,00 hr,27 min	Unknown

Device Section:

Buttons: Search Device, Search Device via MAC, Add to this System

Port Settings

1. IR Voltage: Click the drop-down menu to select the 5V/12V IR voltage.

2. IO Voltage: Click the drop-down menu to select the 5V/12V IO voltage.

3. IO 1 Direction: Click the drop-down menu to set the IO 1 direction (Input/ Output).

4. IO 1: Click the drop-down menu to set the IO 1 level (Low/ High).

5. IO 2 Direction: Click the drop-down menu to set the IO 2 direction (Input/ Output).

6. IO 2: Click the drop-down menu to set the IO 2 level (Low/ High).

7. Relay 1: Click the drop-down menu to select Open/Close Relay 1.

8. Relay 2: Click the drop-down menu to select Open/Close Relay 2.

Reboot: Click the Reboot button to reboot the Decoder.

Replace: Click to replace the offline Decoder (which is in the system) with an online Decoder (which is not in the system). The method to replace Decoders is the same as the Encoder replacement.

Remove: Click the Remove button to remove the Decoder from the system.

Remove All: Click this button to remove all Decoders from the system.

Factory Reset: Click this button to restore the Decoder to factory settings.



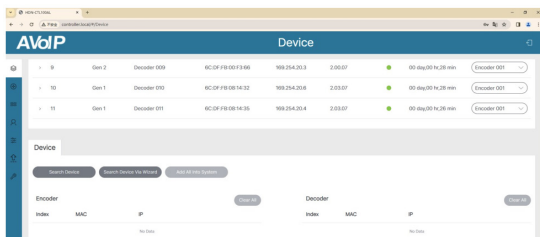

Device

- 1. Search Device:** Click this button to search devices which are not in the system.
- 2. Search Device Via Wizard:** Click this button to switch back to the IP mode select interface and follow the Wizard to set up the system.
- 3. Add All Into System:** Click this button to add all searched devices into the system, then the devices will be listed on the Encoder/Decoder list.

■ Matrix Page

Matrix Switching Function

1. Left-click the Encoder and drag it to Decoder, then release the mouse to realize one-to-one switching.

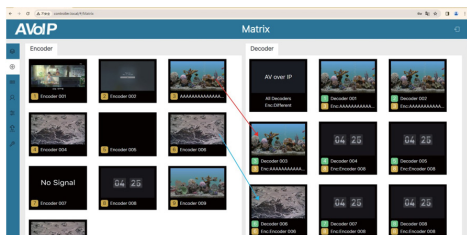

2. Left-click the Encoder and drag it to All Decoders, then release the mouse to realize one-to-all switching.

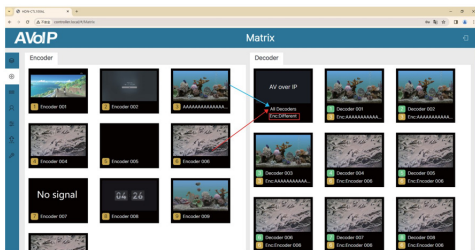

Note: Encoders can only be dragged to the Decoder preview of the same type to achieve signal switching.



Connecting for a Smarter Future

For one-to-all switching, only the Decoders of the same type will output the same signal, as shown in the above figure, only Decoders 004~008 output the signal from Encoder 006, because these Encoders and Decoders belong to the same type.

3. Left-click the Encoder and drag it to multiple Decoders, then release the mouse to realize one-to-many switching.

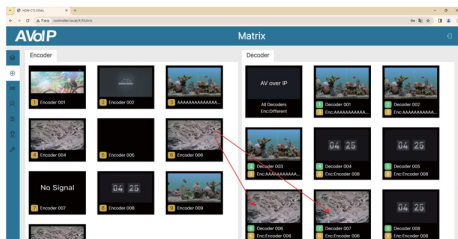

Corresponding Relationship Query

Double-click the preview image of Decoder to check the Video/Audio/IR/ RS-232/USB corresponding relationship between the Encoder and Decoder.

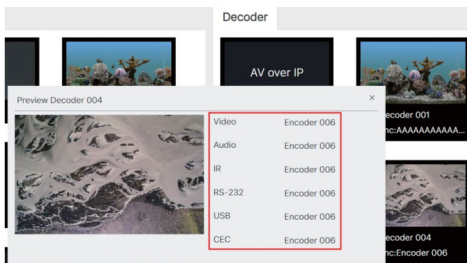

■ Video Wall Page

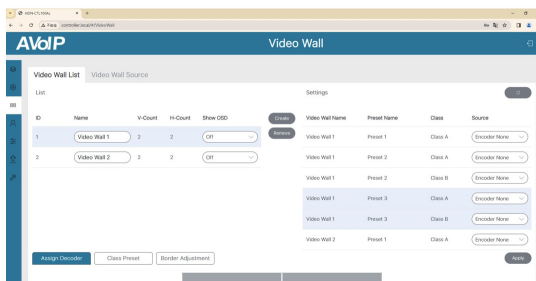

Connecting for a Smarter Future

Video Wall Creation

On the Video Wall List interface of this page, you can create and configure video wall as required. Please follow below steps to create and configure a video wall.

Step 1: Click “Create”, a pop-up window will be shown as below.



Create a new Video Wall x

Video Wall ID

Video Wall Name

Row Number

Column Number

You can set the Video Wall ID, Video Wall Name, Row Number and Column Number. Then click “Go” to create the video wall.

Note:

- (1) Up to 9 video walls can be created.
- (2) The video wall name can be changed after the video wall is created.

Step 2: Select the video wall that you want to configure, then click “Assign Decoder” at the bottom of the Video Wall List interface to enter the Decoder assignment interface. Click each screen to select the corresponding Decoder device, then click “Apply” to take effect.

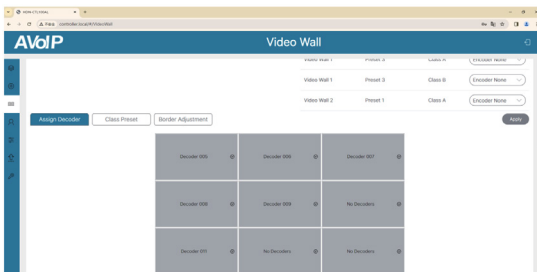

Step 3: Click “Class Preset” to enter the class configuration preset interface, then click each screen to select the corresponding Class as required (the same class name will form a video wall, you can create a regular or irregular video wall by Class Preset). Then click “Apply” to take effect.

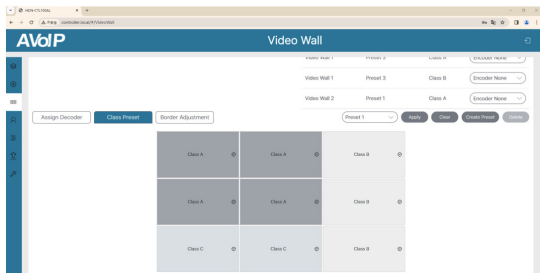

Connecting for a Smarter Future

The preset name can be changed with letters or numbers (max length: 16 characters). Besides, you can click the drop-down menu icon behind the preset name to switch different presets (the selected preset will be high- lighted in Settings), click “Create Preset” to create up to 9 configurations for different application scenarios, click “Clear” to clear and reset video wall class settings, or click “Delete” to delete the current class preset from the system. After setting, you should click “Apply” to take effect.

Step 4: Click “Border Adjustment” to enter the Border Adjustment interface, then click the drop-down menu to set the Base Width, Image Width, Base Height and Image Height. Finally, click “Apply” to adjust the border of each Decoder, or click “Apply All” to adjust the borders of all Decoders.

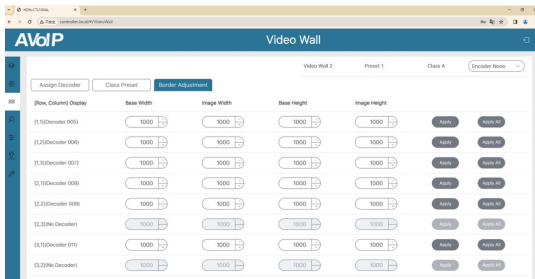

Note: The Base value cannot be more than 2 times the Image value.

Video Wall Source

After the video wall is created and configured, you can click the Video Wall Source tab to check the video wall preview, video wall class, and its corresponding signal source. Besides, you can directly drag Encoders to the video wall to change signal sources, click the “VW” icon on the preview of video wall to switch different video walls, or click the “Pre” icon to switch different presets.

Note:

(1) If the Encoder is offline, it can't be dragged to the matrix of video wall.

(2) Only Encoders of the same type can be dragged to the video wall to switch signals.

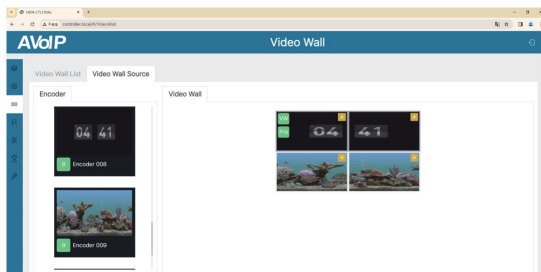

Video Wall Remove

If you want to delete a video wall, just select the video wall on the “Video Wall List”, then click “Remove”. A prompt window will pop up and you can delete it after clicking “Yes”.



Connecting for a Smarter Future

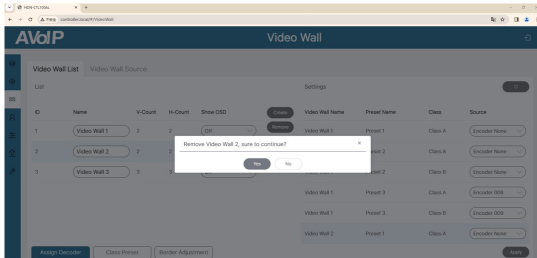

Notes:

- (1) Each Decoder can be set into a part of a video wall array. Each system can contain multiple video walls with different sizes. Each video wall can be assigned to different screens and different layouts that range from 1x2 up to 9x9.
- (2) The controller creates and manages the video wall configurations and provides a simplified control interface and API commands to third party control system.

■ **Users Page**

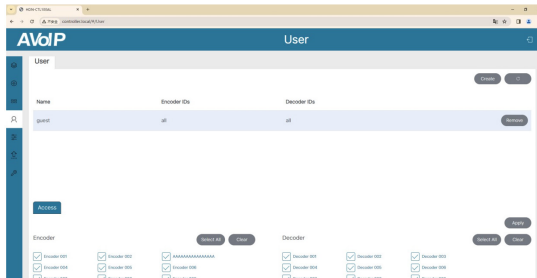

On this page, you can add new user accounts with their own control privileges. This will allow you to create a unique login and limit features such as inputs and outputs that each person has access to. Follow steps below to create a new User.

Step 1: Click “Create”, a pop-up window will be shown as below.

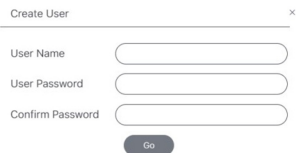

The image shows a pop-up window titled "Create User" with a close button (x) in the top right corner. The form contains three input fields: "User Name", "User Password", and "Confirm Password". Below the input fields is a "Go" button.

Step 2: Input the User Name, User Password and Confirm Password. Then click “Go” to create the User.

Notes:

(1) The user name requires a minimum of 6 characters and a maximum length of 12 characters. Special characters are not supported; The password has a minimum of 6 characters and a maximum of 8 characters.

(2) The Password and Confirm Password must be the same.



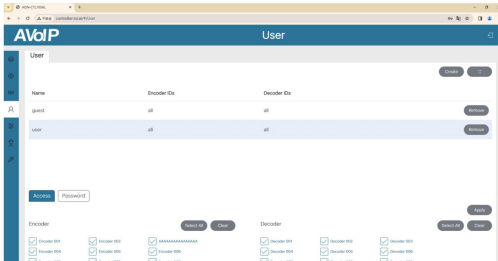

After the new User is created, you can select the Encoders and Decoders as required by checking the devices on the bottom of the User page one by one, or directly click “Select All” to select all devices in the system. Then click “Apply” to take effect. Besides, you can click “Password” to change the User’s password, or click “Remove” to delete the User. If you want to login with the new User, just click the logout icon at the upper right corner of this page to log out, and then login with the new user name and password.

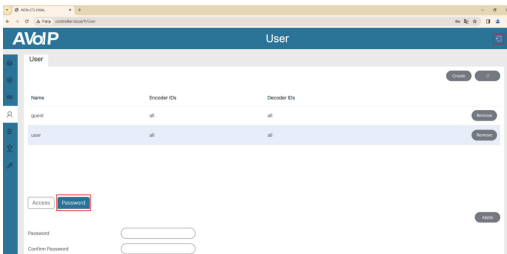

■ Controller Settings Page

System Configurations: Click “Save” to save the current configuration; click “Load” to load the system configuration JSON file and replace the current system configurations (It’s strongly recommended to save the current configurations before loading); click “Clear” to clear system configurations already created and configured in the controller, and you need to set up the system again.

Controller Settings

1. General: The general settings of the Controller. You can check the Controller Version, GUI Version and Domain Name. In addition, you can click the drop-down menu to set the RS-232 BaudRate and HTTPS.



AVoIP Controller Settings

Controller Settings

General

Version: 7.00.F10.2 GUI Version: 5.17.02
 RS-232 BaudRate: 57600 Domain Name: controller
 HTTPS: Off

Control Network

DHCP: Off Subnet Mask: 255.255.255.0
 IP Address: 192.168.10.101 Gateway: 192.168.10.1

Video Network

DHCP: Off Subnet Mask: 255.255.0.0
 IP Address: 192.254.8.100 Gateway: 192.254.8.1

Controller Reset

Settings Home Network Setup Reset All

2. Control Network: The network port configuration of the Controller connected to the router, PC directly or network Switch in where the PC for control is. When DHCP is set to “Off”, you can manually set the IP Address, Subnet Mask and Gateway as required, then click “Apply” to take effect. When DHCP is set to “On”, the system will search and fill the IP Address with the one assigned by the router automatically.

Note: When DHCP is set to “Off” which is in Static IP mode, the network settings of Control LAN and PC should stay in same network segment. Otherwise, the controller Web GUI can not be accessed from PC until you change PC network settings in same network segment.

3. Video Network: The network port configuration of the Controller connected to the network where the Encoders and Decoders stay. When DHCP is set to “Off”, you can manually set the IP Address, Subnet Mask and Gateway as required, then click “Apply” to take effect. When DHCP is set to “On”, the system will search and fill the IP Address with the one assigned by the router automatically.

Note: When DHCP is set to “Off” which is in Static IP mode, the network settings of Video LAN and Encoders/Decoders should stay in same network segment. Otherwise, Encoders/Decoders would be showed as offline. In this case, you should change Video LAN or Encoders/Decoders IP settings to be in same network segment to bring Encoders/Decoders back online. If the Encoders/Decoders are actually alive in the system but with incorrect network segment settings, even though Encoders/Decoders are showing offline, their network settings including IP address can be changed and set.

4. Controller Reset: Click “Settings Reset” to reset controller all settings except network settings; Click “Network Reset” to reset controller network settings; Click “Reset All” to reset controller all settings including network settings.

■ **Firmware Update Page**

1. Upload User EDID 1/2: Click the button to open an EDID binary file and upload it to User EDID 1/2.

2. Upload Decoder Logo Picture: Click the button to upload the Decoder Logo Picture. Then click “Update All” to apply the picture for all Decoders or click “Update” to apply the picture for a single Decoder.

Note: The jpg picture must be greater than 4kB, less than or equal to 512kB, and the resolution of the picture must be less than or equal to 1920x1080.



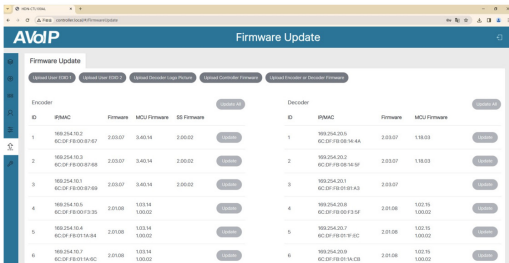

3. Upload Controller Firmware: Click the button to upload the Controller update firmware.

4. Upload Encoder or Decoder Firmware: Click the button to upload the Encoder/Decoder update firmware. After loading, you need to click “Update All” to update firmware for all Encoders/Decoders, or click “Update” to update firmware for a single Encoder/Decoder.

■ Password Update Page

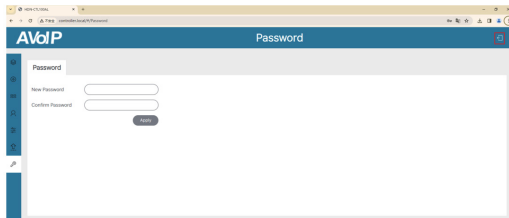

On this page, you can change the password by inputting the New Password and Confirm Password, and then clicking “Apply” to take effect.

Notes:

(1) The password requires a minimum length of 6 characters and a maximum of 8 characters. Special characters are not supported.

(2) The New Password and Confirm Password must be the same.

(3) After changing password, the system will skip to the Web GUI login interface automatically. You need to log in the Web GUI again with the new password.

In addition, there is a logout icon in the upper right corner of each page of the Web GUI. Clicking the icon will exit the Web GUI and automatically skip to the login interface.

8. Application Example 1

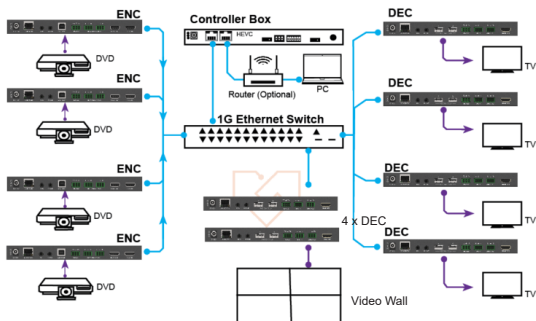

Notes:

(1) The Controller has two LAN ports, one is Video LAN and the other one is Control LAN. The purpose of designing Controller with two LAN ports is to isolate audio/video (AV) network from control network.



Connecting for a Smarter Future

So to make AV network as an independent network which can not be accessed from control network directly it's for bringing network security and avoiding AV network traffic flowing into the network in which the controls and managements are for the IP system.

The strongly recommended system setup is connecting Video LAN and Encoders/Decoders in a network Switch, connecting Control LAN and PC in another network Switch. The controls from Control LAN can be achieved by Web GUI/Telnet or SSH login/API commands, all these controls can be bridged by the Controller and applied onto Video LAN. The two LANs are isolated.

For simple usage, you can only connect all Encoders/Decoders and Video LAN and PC RJ-45 port into a single network, and let the Control LAN port not-connected (floating), as Video LAN also supports Web GUI/Telnet or SSH login/API commands controls, this seems "convenient" for general use scenarios, but this is only suggested for system in which there is no network isolation requirement or network traffic non-sensitive.

Only Control LAN connected while Video LAN floating, this is not allowed.

(2) For the default IP mode of Control LAN port of the Controller Box is DHCP, the PC also needs to be set to "Obtain an IP address automatically" mode, and an optional DHCP server (e.g. network router) is recommended in the system.

(3) If there is no DHCP server in the system, 192.168.6.100 will be used as the IP address of Control LAN port. You need to set the IP address of the PC to be in the same network segment. For example, set PC's IP address as 192.168.6.88.

(4) You can access the Web GUI by inputting URL "http://controller.local" or the Control LAN port IP address 192.168.6.100 (in case of no optional router) on your computer's browser.

(5) No need to care about settings of Video LAN port of the Controller Box, as they are managed by Controller automatically (Default).

(6) When the Network Switch does not support POE, the Encoder, Decoder and Controller Box should be powered by DC power adapter.



The terms HDMI and HDMI High-Definition Multimedia interface, and the HDMI Logo are trademarks or registered trademarks of HDMI Licensing LLC in the United States and other countries.



Connecting for a Smarter Future

Headquarters
46 Corporate Park #130
Irvine, CA 92606
949-701-4742
info@vigillink.com

For order support, please contact your Distributor or Reseller.

For technical support, check with the our website www.vigillink.com
or contact info@vigillink.com