

**FOR PROMPT SERVICE & PARTS
PLEASE CONTACT US AT
www.RABAudio.com/contact-us**

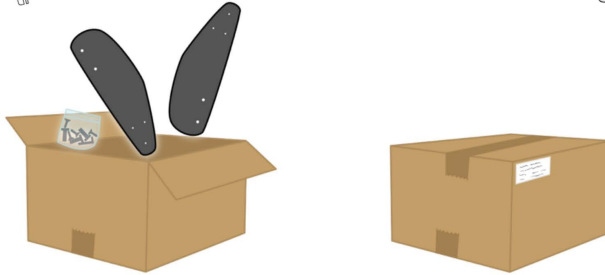

EXTRA INFORMATION

Use a Phillips bit screwdriver when attaching gear. The rack rails take 10/32 thread rack screws. Using any other rack screw is not advisable.



READ BEFORE WATCHING
This video has yet to be updated. We have replaced the 3/4" black screws for attachment of rack rails with 7/16" zinc plated screws.

ASSEMBLY CERTIFIED BY

PACKAGED & INSPECTED BY

MM/DD/YY

MM SS

MM SS



RAB

AUDIO

ProRak

Compact and
Key Desks

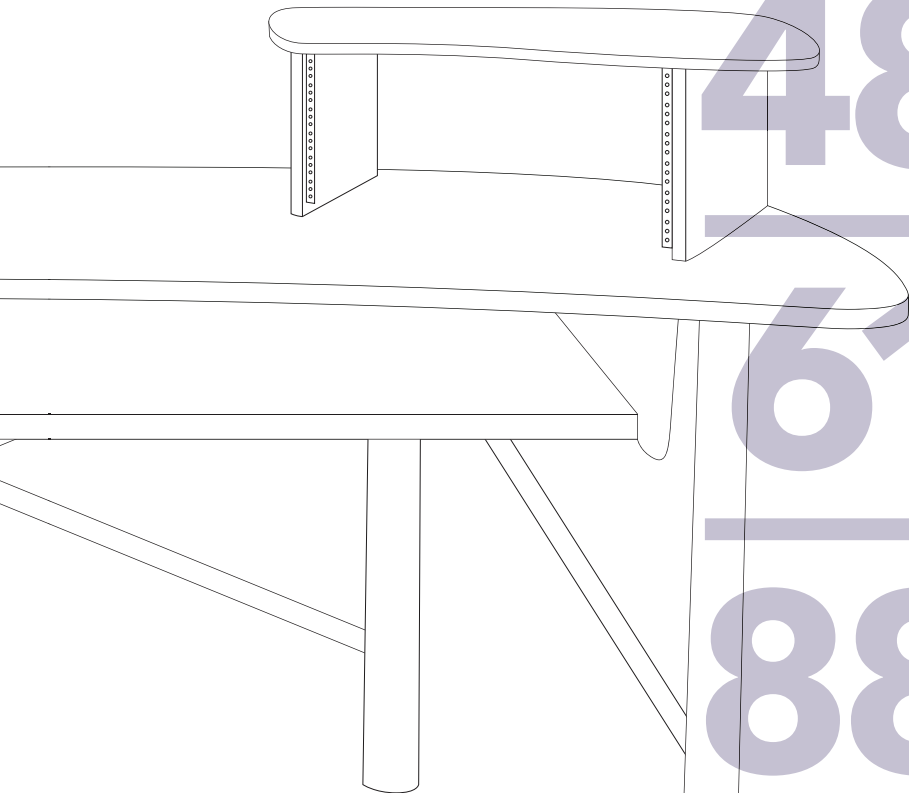

48

61

88

PARTS QUANTITY	DESCRIPTION
4	Legs
2	Span Braces LONG (back span)
2	Span Braces SHORT (sides)
8	Wing Nuts
8	10-32 Rack Screws

Legs

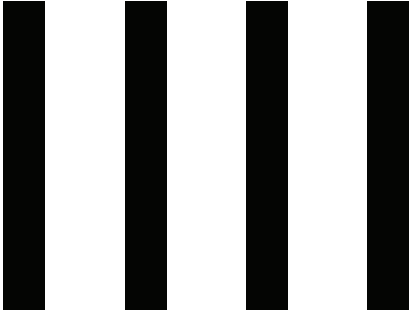

Span Braces



Wing Nuts

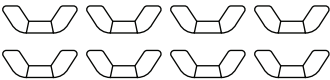

10-32 Thread Rack Screws

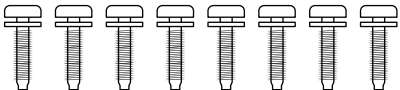

ASSEMBLY

Tools required: Phillips screwdriver or bit

1. Start by removing the outer packaging. Begin and complete the assembly with the unit resting in the base of the packaging.
2. Simply screw the numbered legs onto the matching numbered mounting plate attached to the underside of the workstation.
3. Attach the span braces to the pre-positioned brackets on the legs using the wing nuts.
4. Lift your workstation onto its legs and remove the remainder of the packaging. You are ready to load your gear.

Instructions for keyboard adjustment ProRak 61, MK61, ProRak 88,

1. Remove male catches (2) located on the underside of the keyboard tray. (4 screws total)
2. Remove the keyboard tray by fully extending the tray in the outward position and releasing the catch mechanism. *red plastic tab located in the slide*
3. With the tray now removed relocate the slide mechanism to the desired height. The holes are pre-drilled for you to the proper diameter.
4. Reinsert the tray until the locking mechanism catches and reinstall the male catches to the underside on the keyboard tray.



PLEASE NOTE BEFORE LOADING YOUR GEAR

Use a #2 phillips bit or screwdriver. You may feel a slight resistance for the first 2-3 turns when inserting your 10-32 thread screws into the Rack Rails. This is due to the powder coating process on the Rack Rail itself, after 2-3 turns the coating will clear from the thread & turn freely.

Do not attempt to remove the racking shelf from the table

Do not contact your dealer, please visit
www.RABAudio.com/contact-us for parts and services.

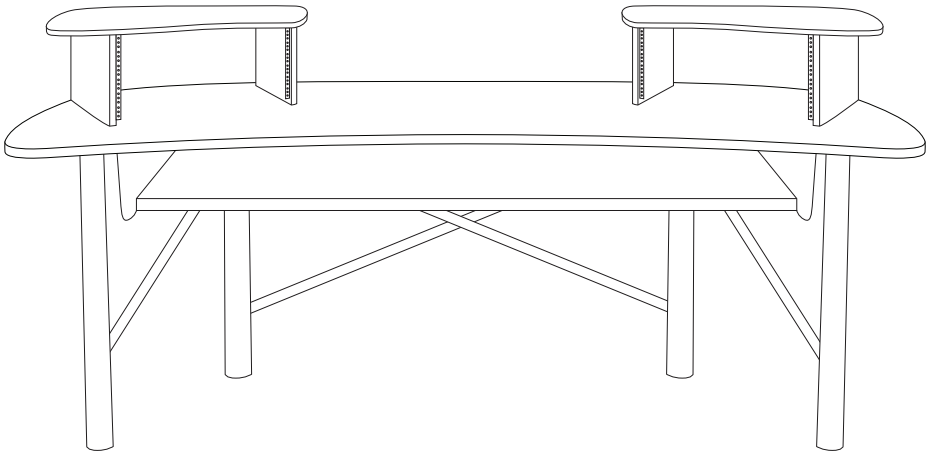

RAB

AUDIO

1507 S. Olive St. South Bend, In. 46619
www.rabaudio.com