



View this document in HTML
crestron.com/docs/9478



Product Manual

DSS-100

Desk Scheduling Status Indicator

The original language version of this document is U.S. English.
All other languages are a translation of the original document.

Regulatory Model: M202301001

Crestron product development software is licensed to Crestron dealers and Crestron Service Providers (CSPs) under a limited nonexclusive, nontransferable Software Development Tools License Agreement. Crestron product operating system software is licensed to Crestron dealers, CSPs, and end-users under a separate End-User License Agreement. Both of these Agreements can be found on the Crestron website at www.crestron.com/legal/software_license_agreement.

The product warranty can be found at www.crestron.com/warranty.

The specific patents that cover Crestron products are listed online at www.crestron.com/legal/patents.

Certain Crestron products contain open source software. For specific information, please visit www.crestron.com/opensource.

Crestron, the Crestron logo, and XiO Cloud are either trademarks or registered trademarks of Crestron Electronics, Inc. in the United States and/or other countries. 3M and Dual Lock are either trademarks or registered trademarks of 3M in the United States and/or other countries. Apple, App Store, and iPhone are either trademarks or registered trademarks of Apple, Inc. in the United States and/or other countries. Bluetooth is either a trademark or registered trademark of Bluetooth SIG, Inc. in the United States and/or other countries. Android and Google Play are either trademarks or registered trademarks of Google Inc. in the United States and/or other countries. Azure and Microsoft are either trademarks or registered trademarks of Microsoft Corporation in the United States and/or other countries. MOO is either a trademark or a registered trademark of MOO, Inc. in the United States and/or other countries. Spaceti is either a trademark or a registered trademark of Spaceti s.r.o in the United States and/or other countries. USB-C and USB Type-C are either trademarks or registered trademarks of USB Implementers Forum, Inc. in the United States and/or other countries. Wi-Fi is either a trademark or a registered trademark of Wi-Fi Alliance in the United States and/or other countries. Other trademarks, registered trademarks, and trade names may be used in this document to refer to either the entities claiming the marks and names or their products. Crestron disclaims any proprietary interest in the marks and names of others. Crestron is not responsible for errors in typography or photography.

©2024 Crestron Electronics, Inc.

Contents

- DSS-100** **1**
 - Desk Scheduling Status Indicator 1
 - Features 2
 - Third-Party Scheduling Partners 2
 - Crestron Device Assistant Setup 3
 - XiO Cloud Service 3
 - Integrated LEDs 3
 - Single-Wire USB Power 3
 - Custom Scheduling Placards 3
 - Wi-Fi Connectivity 3
 - Low-Profile Installation 4
 - Supported Scheduling Partners 5
- Specifications** **6**
 - Product Specifications 6
 - Dimension Drawings 8
- Getting Started** **9**
- Installation** **10**
 - In the Box 10
 - Prepare for Installation 10
 - Select a Mounting Location 11
 - Mount the Wire Saddles 11
 - Mount the Device 12
 - Insert a Placard 14
- Configuration** **16**
 - Initial Setup 17
 - Prepare the XiO Cloud Environment 17
 - Generate Custom Scheduling Placards 18
 - Commission via the Crestron Device Assistant App 19
 - Update Firmware 31
 - Local Configuration 32
 - Network Port List 33
 - Perform a Factory Restore 34
- Troubleshooting** **35**
- Resources** **37**
 - Crestron Support and Training 37
 - Product Certificates 37
 - Related Documentation 37

DSS-100

Desk Scheduling Status Indicator

The [DSS-100](#) desk scheduling indicator is designed to enhance and simplify desk scheduling across an enterprise. The DSS-100 installs on the underside of a desk or similar mounting surface, providing a clear indication of the desk availability via its integrated tricolor LEDs. Custom scheduling placards are generated and installed into the DSS-100, which include a unique QR code linking directly to the desk schedule and reservation functions. The DSS-100 also integrates seamlessly with a variety of popular third-party scheduling partners via the [XiO Cloud® provisioning and management service](#).

Refer to [Getting Started on page 9](#) for important information on using your product and this document.

Features

Key features include:

- Compact indicator designed specifically for desk scheduling applications
- Integrates directly with various third-party scheduling partners via the XiO Cloud® provisioning and management service
- Setup via the Crestron Device Assistant mobile application over Bluetooth® communications
- Monitoring via the XiO Cloud service
- Integrated LEDs illuminate solid, flash, or breathe to indicate desk availability
- Supports custom scheduling placards with QR codes linking to the desk scheduling resource
- Single-wire USB power
- Wi-Fi® network connectivity
- Low-profile installation on the underside of a desk or similar mounting surface



Third-Party Scheduling Partners

The DSS-100 supports various popular third-party scheduling partners, making it easy to integrate desks directly into the existing enterprise scheduling calendar with no programming required. New partners are made available via the XiO Cloud service. Setup is as simple as selecting the desired scheduling partner from XiO Cloud and then creating reservable desks for each DSS-100 within the partner calendar system.^{1,2}

Crestron Device Assistant Setup

Device setup occurs entirely through the Crestron Device Assistant mobile application for [Apple® iPhone®](#) and [Android™ OS](#) devices over Bluetooth® communications. After a BLE connection has been established, the Crestron Device Assistant app claims the device into the XiO Cloud service and places it on the Wi-Fi® network in only a few simple steps.³

XiO Cloud Service

The DSS-100 works exclusively with the XiO Cloud service, which is an IoT (Internet of Things) based platform for remotely provisioning, monitoring, and managing Crestron devices across an enterprise or an entire client base. XiO Cloud is built on the Microsoft® Azure® software platform and utilizes Microsoft's industry leading Azure IoT Hub technology. XiO Cloud enables installers and IT managers to deploy and manage thousands of devices simultaneously. Unlike other virtual machine based cloud solutions, Azure services provide unlimited scalability to suit the ever growing needs of an enterprise. For more information, visit www.crestron.com/xiocloud.

Integrated LEDs

The DSS-100 provides an integrated LED ring that gives visual indication of the desk availability as part of a complete enterprise scheduling solution. The tricolor LEDs can illuminate solidly, flash, or breathe to indicate the desk availability. The LED behavior is controlled by the scheduling partner.

Single-Wire USB Power

Power is supplied to the DSS-100 by a single USB cable. A 6 ft (1.83 m) USB-A to USB-C® cable is included with the device that connects to a USB power source. Wire saddles and tie wraps are also included to neatly route the cable from the power source to the device.

Custom Scheduling Placards

Custom scheduling placards must be created for each reservable desk that is associated with a DSS-100. Each custom scheduling placard contains the name of the desk and a QR code that opens the schedule and reservation functions for that desk on a mobile device. Custom scheduling placards are generated within the scheduling partner account and can be printed locally or ordered via a partnership with the [MOO® online printing service](#). A removable tray allows the placards to be easily installed into or removed from the DSS-100.⁴

Wi-Fi Connectivity

The DSS-100 connects to the network over Wi-Fi® communications via a wireless SSID to communicate with XiO Cloud.

- Support for 802.11b/g/n protocols at the 2.4 GHz band affords wireless performance in many environments.⁵
- Wi-Fi connectivity supports up to 123 ft (37.5 m) of omnidirectional coverage indoors.

Low-Profile Installation

The DSS-100 can be mounted to the flat underside of a desk, table, or similar surface using the provided 3M™ Dual Lock™ fasteners. The front of the DSS-100 containing the placard extends out from under the desk. A compact design allows users to interact with the DSS-100 without interfering with any typical desk usage. If the desk underside is not suitable for installation, a friction pad is provided on the bottom of the device to support freestanding placement on the desk.

Notes:

1. Refer to [Supported Scheduling Partners on page 5](#) for a list of all supported scheduling partners.
2. Additional subscriptions and/or licenses may be required. Refer to each partner's website for details about the capabilities and requirements of its scheduling services. The DSS-100 supports only one partner at a time, which is selected using the XiO Cloud® service. Only the partners approved by Crestron are compatible with the DSS-100. The DSS-100 cannot be interfaced with a control system and cannot be custom programmed for any other functionality. A Wi-Fi® network connection is required.
3. The Crestron Device Assistant app requires login credentials of an XiO Cloud user with Global Admin permissions. For more information, refer to the [XiO Cloud Service User Guide](#).
4. The workflow for generating custom scheduling placards varies by scheduling partner.
5. Wireless range subject to site-specific conditions.

Supported Scheduling Partners

The DSS-100 supports various third-party scheduling partners via the XiO Cloud® service. For more information on selecting a scheduling partner in XiO Cloud, refer to [Prepare the XiO Cloud Environment on page 17](#).

The following scheduling partners are supported:

- [Spaceti® Space Management Platform](#)

NOTE: Support for additional partners will be made available via updates within the XiO Cloud service.

All DSS-100 devices claimed to the XiO Cloud account will use the selected scheduling partner. Multiple scheduling partners are not supported within the same XiO Cloud account. Only scheduling partners approved by Crestron may be used with the DSS-100.

NOTE: Additional subscriptions and/or licenses may be required. Refer to each partner's website for details about the capabilities and requirements of its scheduling services.

For more information on using the selected scheduling partner, refer to the partner's website.

Specifications

Refer to the following product specifications for the DSS-100.

Product Specifications

Scheduling Support

Third-Party Partners	Includes support for various third-party scheduling partners via the XiO Cloud® service. ^{1,2}
-----------------------------	---

Controls and Indicators

Pin Hole	(1) Recessed pin hole; Initiates factory restore, demo mode, diagnostic mode, and firmware upgrade via press-and-hold sequences
LED Ring	(1) Tricolor RGB LED ring; LEDs can illuminate solidly, flash, or breathe based on implementation by the third-party scheduling partner

Connectors

USB C	(1) USB Type-C® connector, female; USB 2.0 device port (power only)
--------------	--

Wireless Communications

Transceiver	IEEE 802.11b/g/n Wi-Fi® communications (2.4 2-way RF), dynamic IP via DHCP, IPv4 only
Security	64 and 128-bit WPA2 PSK with TKIP and AES
Range	Up to 123 ft (37.5 m) ⁵
Bluetooth® Communications	Bluetooth 4.2 (BLE); For connection to Crestron Device Assistant app for initial setup

Power

USB	3.5 W @ 5V USB power
------------	----------------------

Environmental

Temperature	41° to 104°F (5° to 40°C)
Humidity	10% to 95% RH (noncondensing)

Construction

Housing	PC/ABS, black textured
Mounting	Mounts to the underside of a desk using included 3M™ Dual-Lock™ fasteners or freestanding placement on desk surface

Dimensions

Height	1.68 in. (43 mm)
Width	3.00 in. (76 mm)
Depth	1.90 in. (48 mm)

Weight

2.1 oz (60 g)

Compliance

Regulatory Model: M202301001

FCC Part 15 Class B, IC Class B, CE, UL® Listed for US and Canada

Notes:

1. Refer to [Supported Scheduling Partners on page 5](#) for a list of all supported scheduling partners.
2. Additional subscriptions and/or licenses may be required. Refer to each partner's website for details about the capabilities and requirements of its scheduling services. The DSS-100 supports only one partner at a time, which is selected using the XiO Cloud® service. Only the partners approved by Crestron are compatible with the DSS-100. The DSS-100 cannot be interfaced with a control system and cannot be custom programmed for any other functionality. A Wi-Fi® network connection is required.
3. The Crestron Device Assistant app requires login credentials of an XiO Cloud user with Global Admin permissions. For more information, refer to the [XiO Cloud Service User Guide](#).
4. The workflow for generating custom scheduling placards varies by scheduling partner.
5. Wireless range subject to site-specific conditions.

Dimension Drawings

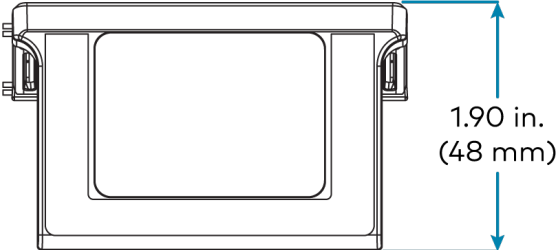
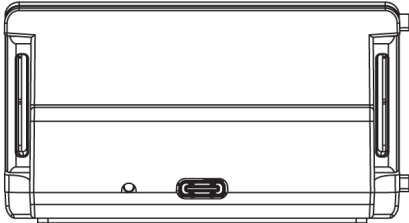
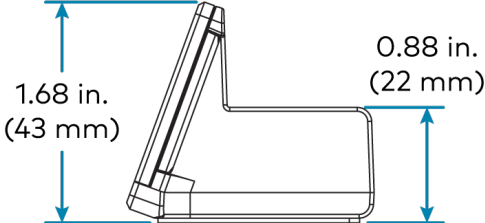
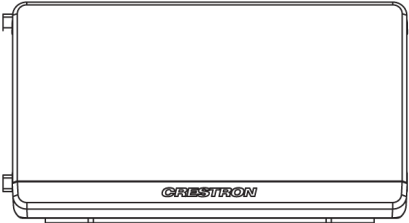
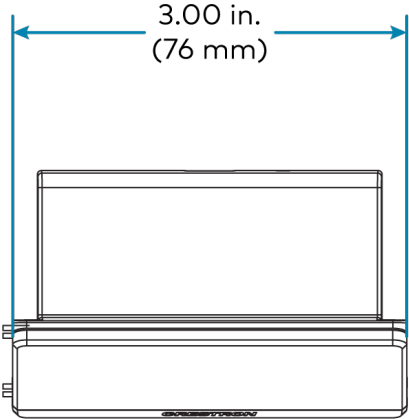

Getting Started

The DSS-100 requires integration with the XiO Cloud® service and a third-party scheduling partner. Prior to purchasing and commissioning the DSS-100, the support provider must work with their customer to ensure the following prerequisites are met.

1. The customer has registered with a supported third-party scheduling partner. Refer to [Supported Scheduling Partners on page 5](#).
2. The support provider has created an XiO Cloud account for the customer and has authorized the scheduling partner in the account settings. Refer to [Prepare the XiO Cloud Environment on page 17](#).

NOTE: Purchase of XiO Cloud licenses is not required to commission the DSS-100 or to authorize a scheduling partner.

3. The customer has created reservable desks in the scheduling partner calendaring system. Refer to the chosen scheduling partner's documentation.
4. The customer has coordinated with their scheduling partner account manager to order and receive custom scheduling placards for each desk that will be associated with a DSS-100. Refer to [Generate Custom Scheduling Placards on page 18](#).
5. The onsite technician has downloaded and installed the Crestron Device Assistant app on a mobile device that will be used for commissioning. Refer to [Commission via the Crestron Device Assistant App on page 19](#).

Additionally, refer to [Installation on page 10](#) for information on how to install the DSS-100 onto a desk.

Installation

Use the following procedures to install the DSS-100.

In the Box

Qty.	Description
1	DSS-100, Desk Scheduling Status Indicator
Additional Items	
1	Cable, USB-A to USB-C™, 6.6 ft (2 m) (2062815)
2	Wire Saddle, Plastic, Adhesive Base (2049849)
2	Tie Wrap, 4 in. (2005429)
1	3M™ Dual Lock™ Fastener, Adhesive, 2.5 x 1 in. (2061988)
1	3M Dual Lock Fastener, Adhesive, 3.5 x 1 in. (2061987)

Prepare for Installation

Isopropyl alcohol (70% minimum) is required for surface cleaning prior to installation.

CAUTION: Observe the following points to ensure the DSS-100 properly bonds to the mounting surface. Failure to properly bond the DSS-100 to the mounting surface could cause the DSS-100 to detach after installation.

- Use isopropyl alcohol (minimum 70%) to clean the mounting surface. Other surface cleaning products can leave a film that will prevent the adhesive from properly bonding to the mounting surface.
- Use a new, clean nonlinting cloth to apply the isopropyl alcohol. The cloth should not have been used with any other cleaning product to ensure that it does not leave a film on the mounting surface.
- Allow the isopropyl alcohol to air dry on the mounting surface for at least one minute before applying adhesive. Do not dry the surface with a cloth prior to applying adhesive.
- Do not apply adhesive to the mounting surface in temperatures below 65°F (19°C).

Select a Mounting Location

The DSS-100 can be mounted to the flat underside of a desk, table, or similar surface using the provided 3M™ Dual Lock™ fasteners. The front of the DSS-100 containing the placard extends out from under the desk.

The chosen mounting location should enable users to easily interact with the DSS-100 placard without interfering with any typical desk usage. The chosen mounting location should allow the extended front of the DSS-100 to sit flush against the edge of the desk with no gap in between.

NOTES:

- The DSS-100 cannot be mounted to desks with angled edge profiles (such as P or knife edges). The DSS-100 must be placed on top of the desk instead. A friction pad is provided on the bottom of the device to keep it in place.
- Most porous and fibered surface materials (such as wood and particleboard) must be sealed to provide a unified surface for adhesion to the Dual Lock fasteners.
- The minimum recommended mounting surface thickness is 3/4 in.

Mount the Wire Saddles

Two adhesive wire saddles are provided that can be used to route the included USB cable from the power source to the DSS-100.

To mount the wire saddles:

1. Choose the mounting locations for the wire saddles under the desk based on the desired USB cable route.
2. Clean and dry the mounting surface thoroughly. Refer to the caution statements at the beginning of [Prepare for Installation on page 10](#) for important cleaning and drying notes.
3. Remove the protective liner from the base of one of the two wire saddles.

CAUTION: The adhesive on the wire saddles is high-strength bond. Once the adhesive comes in contact with a surface, it cannot be removed easily.

4. Press the wire saddle base against the mounting surface firmly for at least 30 seconds to ensure the adhesive bonds to the surface.

NOTE: All air bubbles must be smoothed out and eliminated to ensure a complete bond to the surface.

5. Repeat steps 3–4 for the second wire saddle.

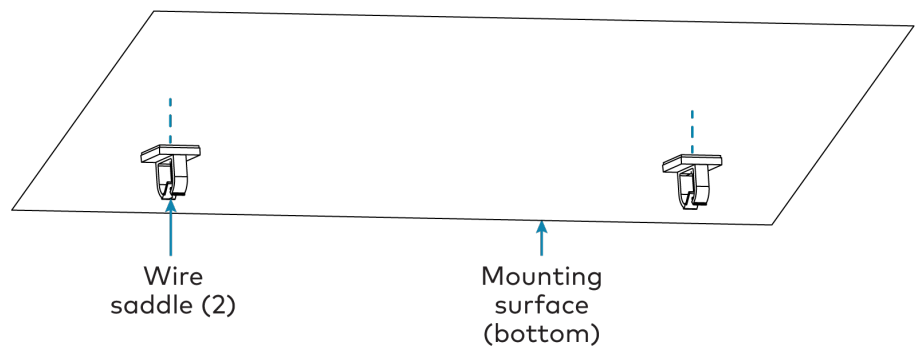

6. Route the USB-C™ connector end of the provided USB cable from the power source to the DSS-100 mounting location through the wire saddles. Each wire saddle provides a clip that can be opened to insert the cable.

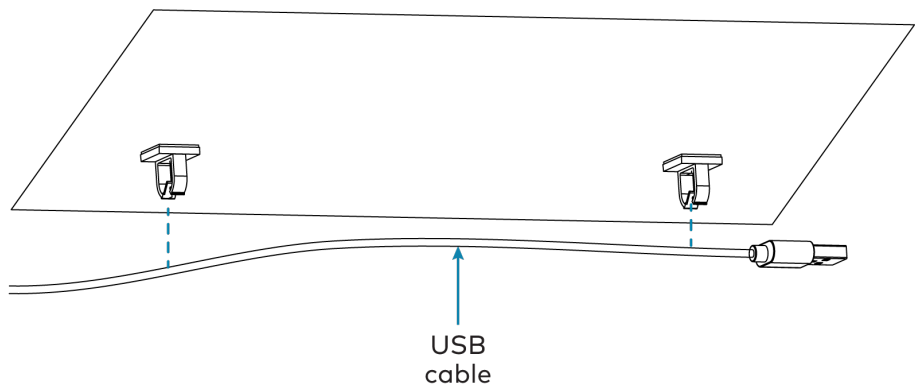

7. (Optional) To reduce slack for shorter cable runs, use the provided tie wraps to bunch the excess cabling.

Mount the Device

To mount the DSS-100 to the underside of a desk:

CAUTION: The adhesive on the provided Dual Lock fasteners is high-strength bond. Once the adhesive comes in contact with a surface, it cannot be removed easily.

1. Clean and dry the mounting surface thoroughly. Refer to the caution statements at the beginning of [Prepare for Installation on page 10](#) for important cleaning and drying notes.
2. Remove the protective liner from the bottom of the 2.5 x 1 in. Dual Lock fastener.
3. Align the 2.5 x 1 in. Dual Lock fastener, adhesive-side down, with the top flat surface of the DSS-100. Do not allow the adhesive to come in contact with the device.

4. After confirming the alignment, press the Dual Lock fastener to the top flat surface of the DSS-100 firmly for at least 30 seconds to ensure the adhesive bonds to the surface.

NOTE: All air bubbles must be smoothed out and eliminated to ensure a complete bond to the surface.

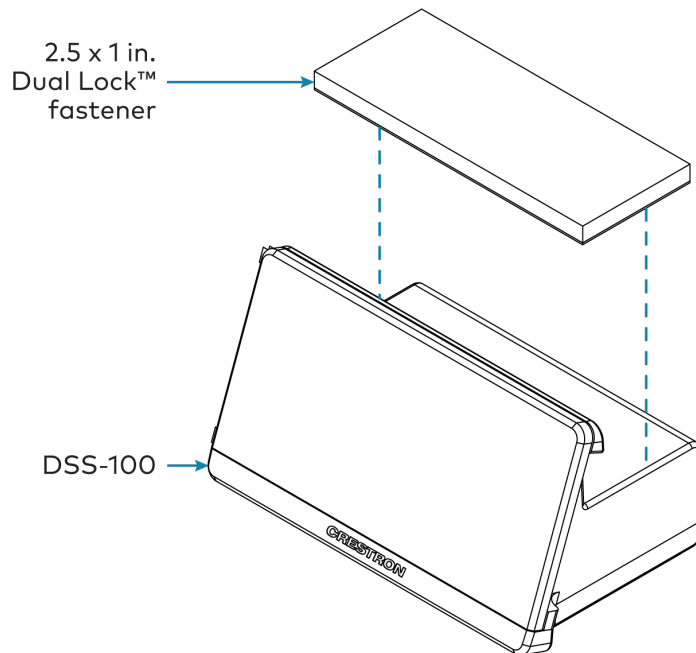

5. Remove the protective liner from the bottom of the 3.5 x 1 in. Dual Lock fastener.
6. Align the 3.5 x 1 in. Dual Lock fastener, adhesive-side up, with the chosen mounting location so that the long edge of the Dual Lock fastener is aligned with the edge of the desk. Do not allow the adhesive to come in contact with the device.
7. After confirming the alignment, press the Dual Lock fastener to the mounting surface firmly for at least 30 seconds to ensure the adhesive bonds to the surface. Refer to the illustration below step 9.

NOTE: All air bubbles must be smoothed out and eliminated to ensure a complete bond to the surface.

8. Press the DSS-100, top-side up, to the mounting surface so that the two Dual Lock fasteners engage. An audible snap is heard when the Dual Lock fasteners engage successfully.

CAUTION: Wait at least 24 hours prior to adjusting the device or disengaging the lock once the Dual Lock fasteners have engaged. Failure to properly cure the Dual Lock fasteners could cause the DSS-100 to detach after installation.

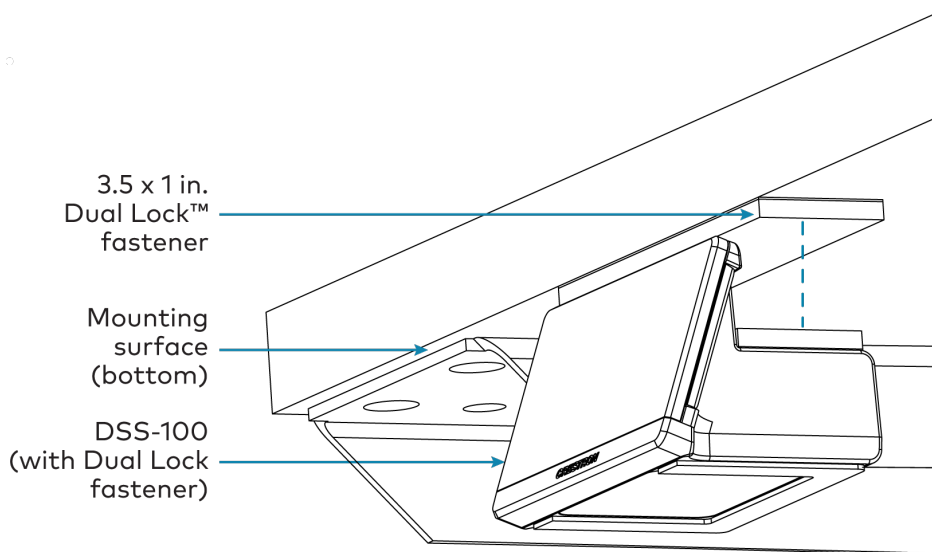

9. Connect the USB-C connector to the rear of the DSS-100. The device LEDs breathe white if the DSS-100 is receiving power.

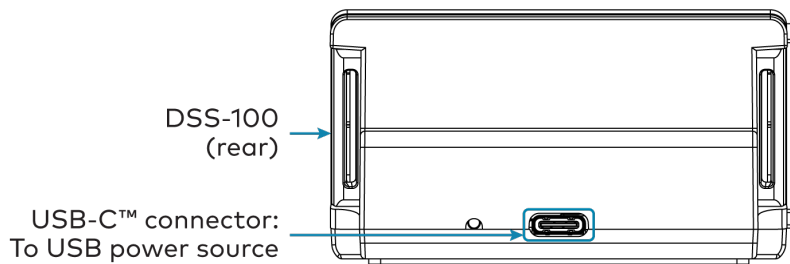

Insert a Placard

DSS-100 uses replaceable placards to indicate the desk name and to provide a QR code that can be scanned to reserve the desk. The DSS-100 ships with a generic placard that must be replaced with a custom scheduling placard after the device has been commissioned. For more information about generating custom placards, refer to [Generate Custom Scheduling Placards on page 18](#).

To insert a custom scheduling placard:

1. Remove the placard tray from the DSS-100 by grasping the lip on the either side of the tray and pulling it out from the device.

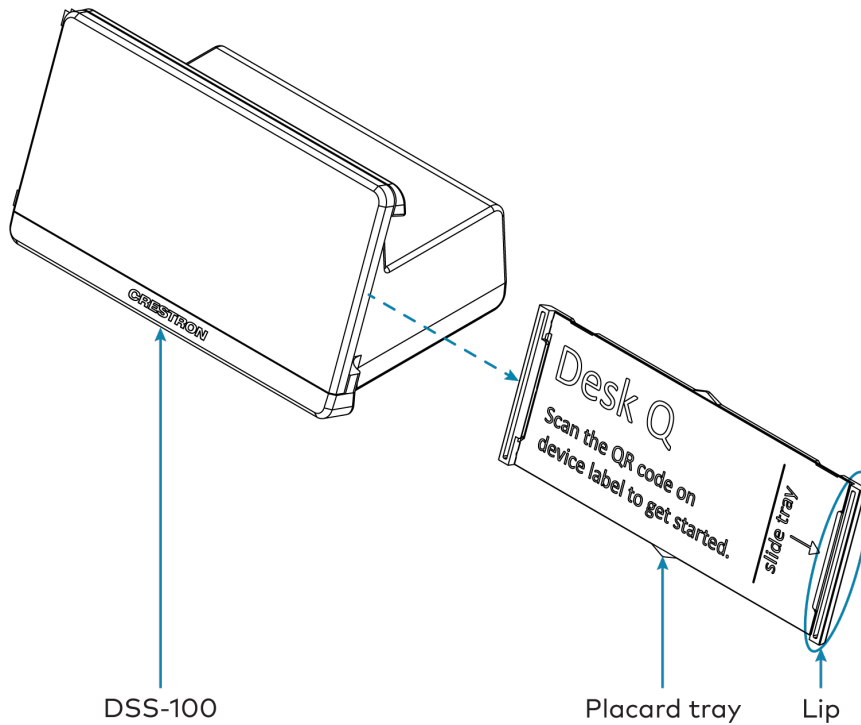

2. Remove the generic placard from the tray by sliding it upward.
3. Insert the custom scheduling placard into the tray by sliding it downward through the guides.

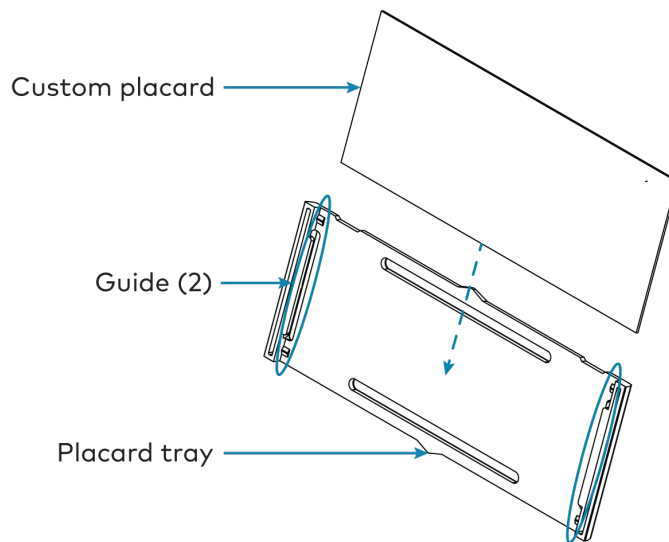

4. Reinsert the tray into its slot in the DSS-100 until it snaps into place.

Configuration

This section provides the following information:

- [Initial Setup](#)
- [Local Configuration](#)
- [Network Port List](#)
- [Perform a Factory Restore](#)

Initial Setup

Use the following procedures to set up the DSS-100 prior to operation.

Prepare the XiO Cloud Environment

The XiO Cloud® service allows supported devices across an enterprise to be managed and configured from one central, secure location in the cloud. The DSS-100 scheduling partner is also managed within the XiO Cloud service account. The DSS-100 is configured to connect to the service by default.

NOTE: An XiO Cloud account is required to use the service. To register for an XiO Cloud account, refer to www.crestron.com/Support/Tools/Licensing-Registration/XiO-Account-Registration. Purchase of XiO Cloud licenses is not required to commission the DSS-100 or to authorize a scheduling partner.

To select a scheduling partner from the XiO Cloud account:

1. Log in to your XiO Cloud account at portal.crestron.io.
2. Select the gear icon  on the left side of the screen.
3. Select **Account Settings**.

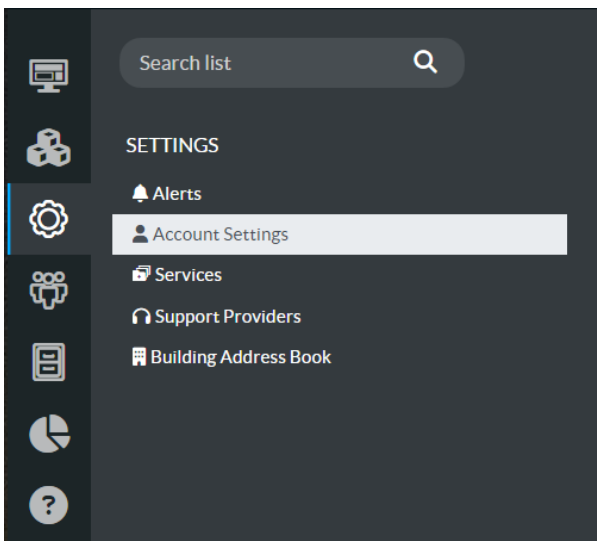

4. Within the **Profile** tab on the right side of the screen, expand the **Scheduling Partner Permissions** accordion, then use the **Partner** drop-down menu to select the desired scheduling partner.

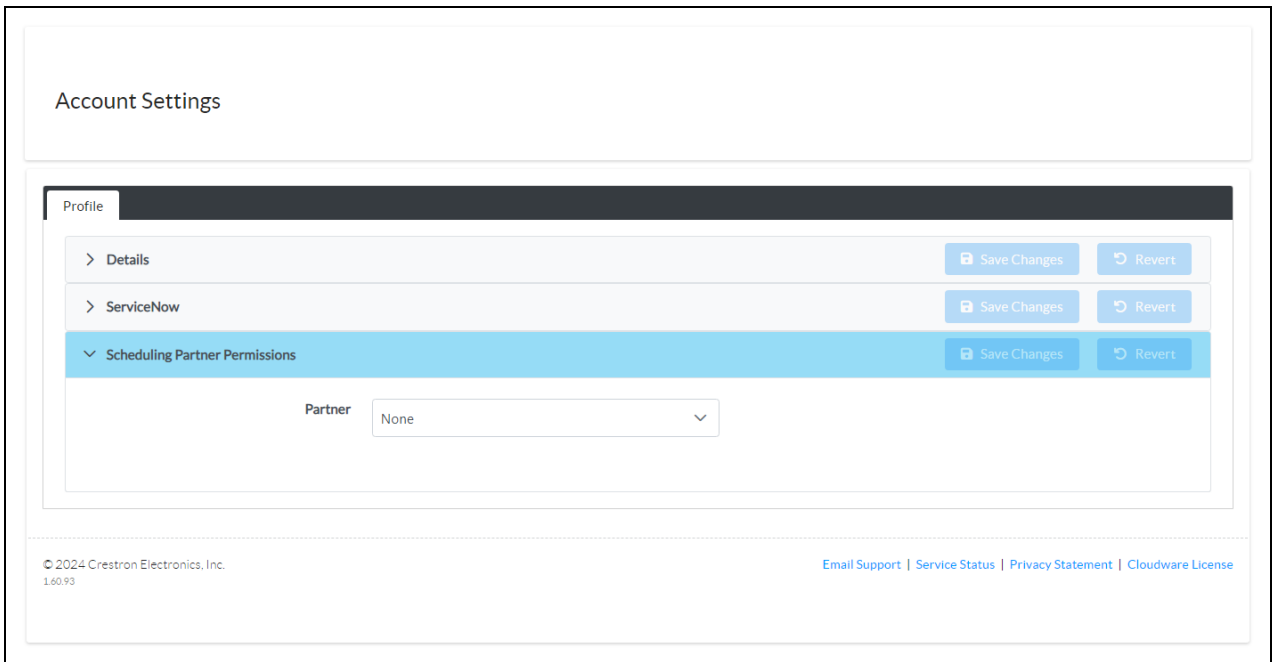

5. Select **Save Changes** on the top right of the accordion.

NOTE: All DSS-100 devices claimed to the XiO Cloud account will use the selected scheduling partner. Multiple scheduling partners are not supported within the same XiO Cloud account.

The DSS-100 connects to the XiO Cloud service using the Crestron Device Assistant app. For more information, refer to [Connect the Device to Wi-Fi and Claim into XiO Cloud on page 26](#).

NOTE: An XiO Cloud user with Global Admin permissions is required to use the Crestron Device Assistant app. For more information on managing XiO Cloud users and permissions, refer to the [XiO Cloud Service User Guide](#).

Generate Custom Scheduling Placards

Custom scheduling placards must be created for each reservable desk that is associated with a DSS-100. Each custom scheduling placard contains the name of the desk and a QR code that opens the schedule and reservation functions for that desk on a mobile device. Custom scheduling placards are generated through the third-party scheduling partner.

To generate custom scheduling placards:

1. Log into an admin account for the scheduling partner.
2. Create desks in the scheduling partner's calendar system that correspond with the reservable desks in your organization that will be associated with a DSS-100. Refer to the scheduling partner documentation for more information.

3. Order custom scheduling placards via the MOO® online printing service:

NOTE: The workflow for ordering placards may differ depending on the chosen partner. Contact your account manager for specific instructions. Refer to Moo's website for additional instructions and information.

- For US orders, refer to moo.com/us/partner/crestron.
- For international orders, refer to moo.com/uk/partner/crestron.

NOTE: For smaller deployments, PDF sheets containing the placards can be printed locally and cut using the guides on the sheet. Up to 18 placards can be generated on a single Letter or A4 sheet (when printed at a scale of 100%).

The custom scheduling placards are required to complete the commissioning process when using the Crestron Device Assistant app. For more information, refer to [Associate the Custom Scheduling Placard on page 29](#).

Commission via the Crestron Device Assistant App

Device commissioning occurs entirely through the Crestron Device Assistant mobile application over Bluetooth® communications. After a BLE connection has been established, the Crestron Device Assistant app claims the device into the XiO Cloud service and places it on the Wi-Fi® network in only a few simple steps.

Use the following procedures to commission the DSS-100 via the Crestron Device Assistant App.

NOTES:

- Placing the app into the background during the commissioning process will cause the app to time out, and any active BLE connection will be terminated. Ensure the app remains in the foreground during the entirety of the commissioning process.
- If the app is installed on a fold phone, the app may return an error when attempting to scan QR codes with the phone folded. Ensure the phone is unfolded when scanning QR codes.

Download the App

The Crestron Device Assistant app is available for download from the App Store® app on supported Apple® iPhone® devices or from the Google Play™ app on supported Android™ OS devices.

Scan the QR code on the bottom of the DSS-100 with your mobile device to open a web page with links to the app download pages for each OS. Then, follow the prompts to download and install the app to the mobile device.

NOTE: If the Crestron Device Assistant app is already installed on the mobile device, scanning the QR code opens the app instead.

Add the Device to the App

To add the DSS-100 to the Crestron Device Assistant app over Bluetooth communications:

NOTE: Ensure that Bluetooth communications are turned on for the mobile device and that the DSS-100 is powered on prior to pairing (indicated by breathing white LEDs). Also ensure that the mobile device is operated close to the DSS-100 for BLE pairing.

1. Open the Crestron Device Assistant app on your mobile device.

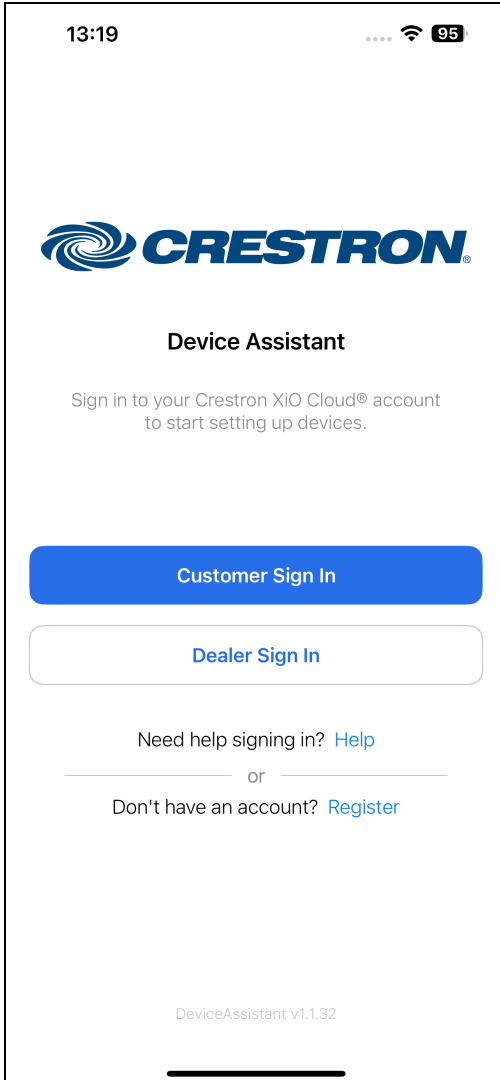

2. Select **Customer Sign in** or **Dealer Sign in** depending on your role. The **Sign in** screen is displayed.

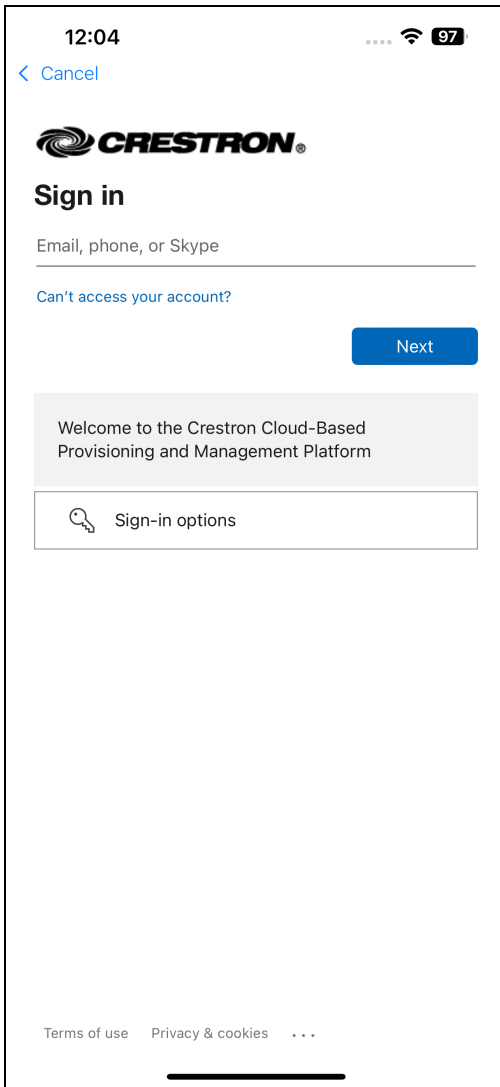

3. Enter the full user name (for example, "jsmith@crestron.io") of an XiO Cloud user with Global Admin permissions for your account. For more information, refer to [Prepare the XiO Cloud Environment on page 17](#).

4. Select **Next**. The **Enter password** screen is displayed.

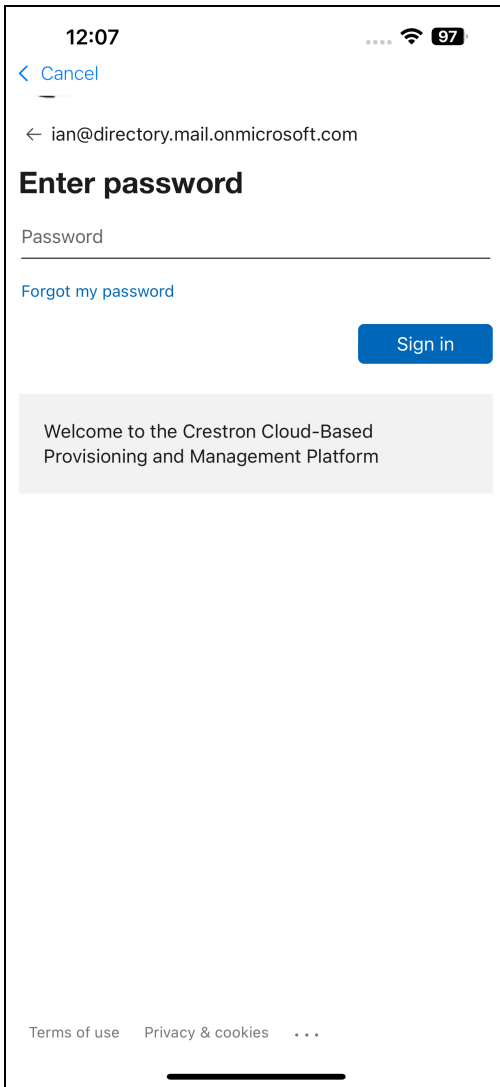

5. Enter the password of the XiO Cloud user with Global Admin permissions entered in step 3.
6. Select **Sign in**.

- When prompted, agree to allow the app to use Bluetooth communications and location services (Android only).

Upon successful sign in, a **Terms and Conditions for Crestron Mobile Apps** screen is displayed.

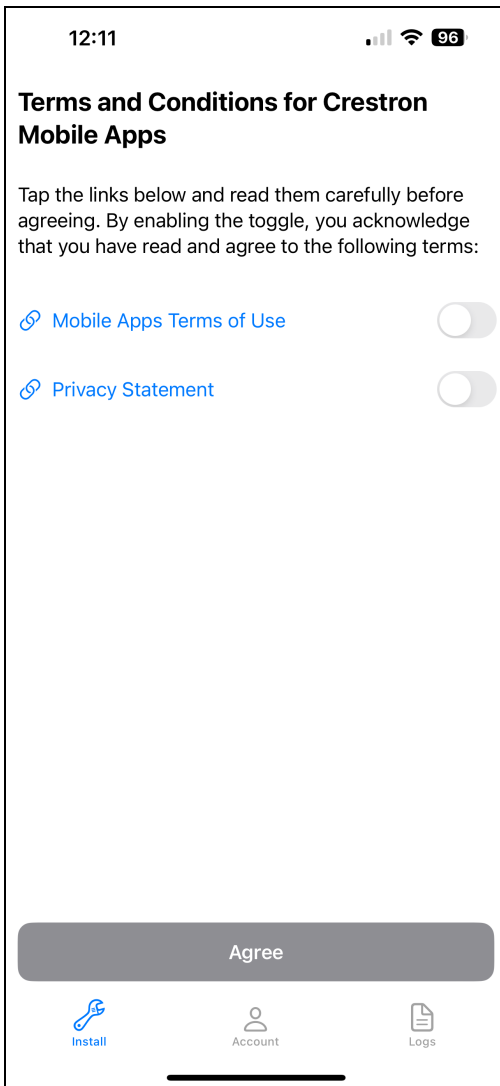

8. Agree to the **Mobile Apps Terms of Use** and **Privacy Statement** by filling their check boxes, then select **Agree**.

The **Add Device** screen is displayed.

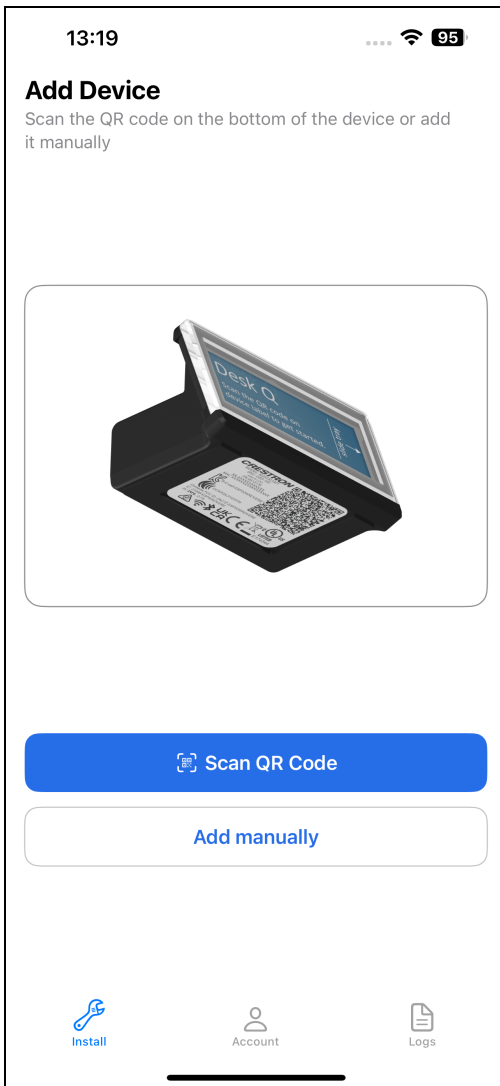

9. Select **Scan QR Code**.

- When prompted, agree to allow the app to use the phone camera, then scan the QR code on the bottom of the DSS-100 using the mobile device camera.

If the QR code scans successfully, a **Confirm Details** screen is shown with information about the device and the XiO Cloud account that will claim it.

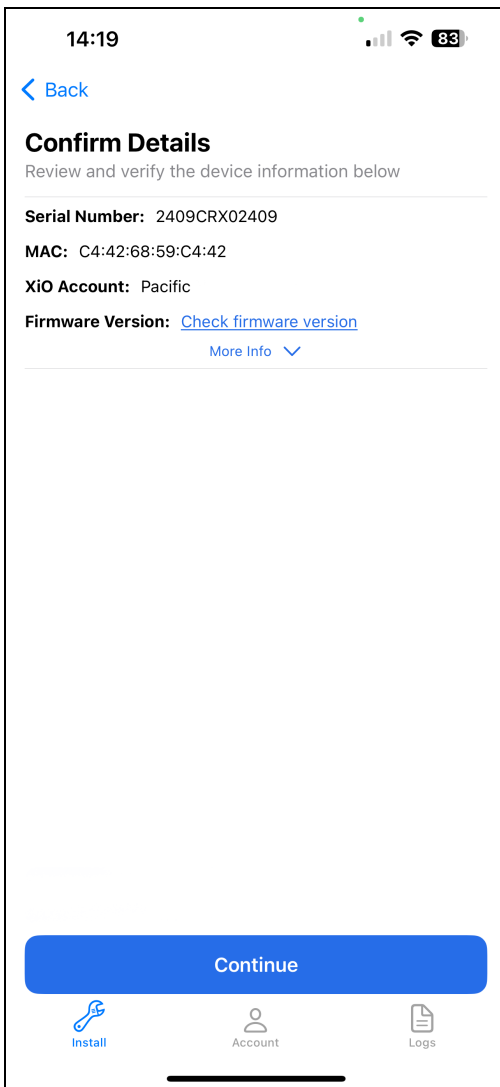

- Select **Continue** to add the device to the app.

NOTE: Alternatively, if the QR code cannot be scanned or if the mobile device camera is not functional, select **Add manually** from the **Add Device** screen. The app will prompt you to enter the serial number and MAC address of the DSS-100, which are both located on the bottom label of the device. Select **Add Device** once the required information has been entered to view the **Confirm Details** screen.

The mobile device will scan for DSS-100 devices advertising BLE communications. Once the mobile device locates the correct DSS-100, the device LEDs turn solid blue to indicate a successful connection, and the Crestron Device Assistant app will proceed to the next step automatically. If no BLE connection is made, an error message is displayed.

Connect the Device to Wi-Fi and Claim into XiO Cloud

Once the DSS-100 is connected to the app successfully, the **Connect Wi-Fi** screen is displayed for establishing a connection to the Wi-Fi network and for claiming the device into the XiO Cloud service.

NOTE: Only 2.4 Ghz SSIDs are supported by the DSS-100.

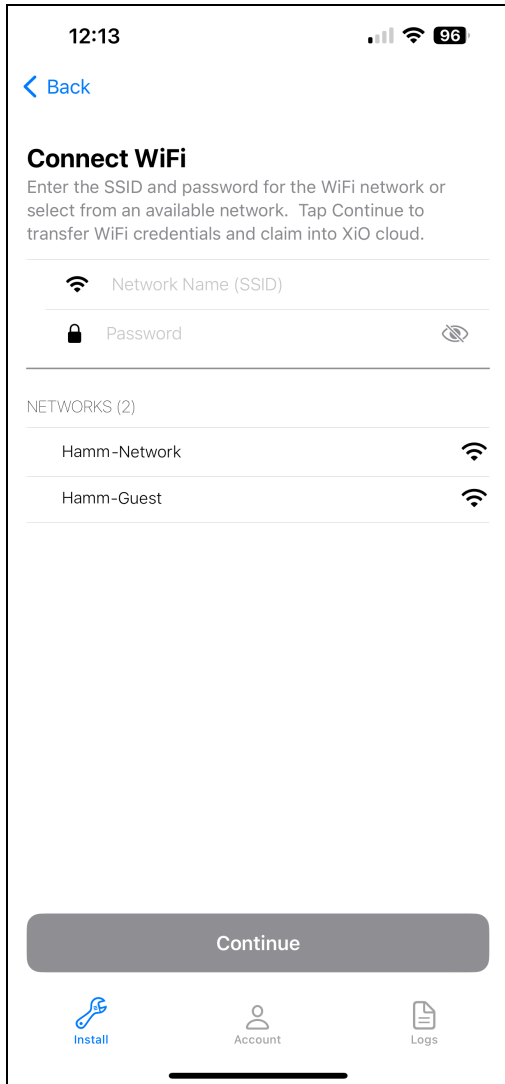

To set up a Wi-Fi network connection:

1. Select the desired SSID from the **Networks** list that populates on the **Connect Wi-Fi** screen. If the desired SSID is not shown, tap in the **Network Name (SSID)** field to enter the SSID manually.
2. Tap in the **Password** field to enter the password for accessing the SSID. Tap the eye icon to the right of the password to show or hide the password characters.
3. Tap **Continue**.

The app will attempt to transfer the selected SSID credentials to the DSS-100 over BLE, and the device LEDs turn white to indicate the pending transfer.

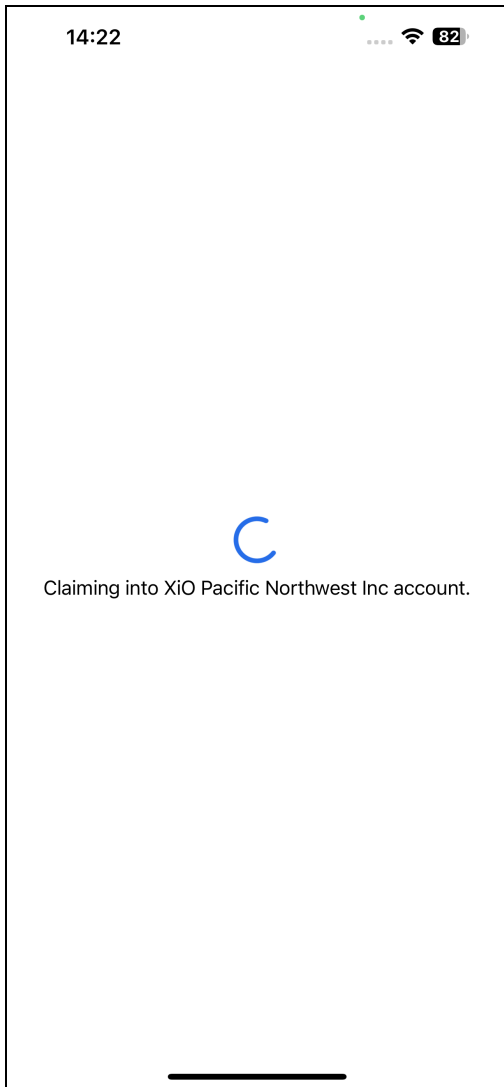

If the transfer is successful, the device LEDs turn cyan (blue green), and the Crestron Device Assistant app will display a success message. Select **OK** to continue to the next screen.

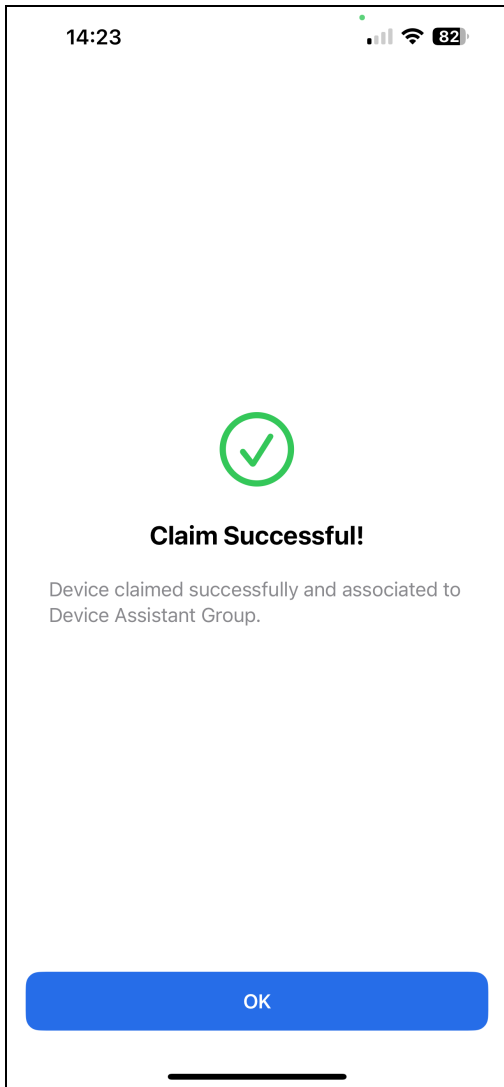

Bluetooth communications are turned off permanently on the DSS-100 (unless it is factory restored), and the device will now use Wi-Fi communications to connect to the network. If the SSID credentials cannot be transferred, an error message is displayed.

The DSS-100 will also be claimed into the environment tree in the XiO Cloud account under **Device Assistant Group** after a Wi-Fi network connection has been established. For more information on associating the device with a desk in XiO Cloud, refer to the [XiO Cloud Service User Guide](#).

Associate the Custom Scheduling Placard

Once the DSS-100 is connected to the Wi-Fi network, the **Associate Placard** screen is displayed for associating the custom scheduling placard with the DSS-100. For more information on generating custom scheduling placards, refer to [Generate Custom Scheduling Placards on page 18](#).

NOTE: If the device commissioning process should be stopped for any reason, select **Abandon Installation**. The DSS-100 must be factory restored and then reconnected to the app and the Wi-Fi network if the process is abandoned.



To associate the DSS-100 with a custom scheduling placard:

1. On the **Associate Placard** screen, select **Scan QR Code**.
2. When prompted, scan the QR code on custom scheduling placard using the mobile device camera.

3. If the QR code scans successfully, an **Insert Placard** screen is shown with a description of how to install the placard into the DSS-100. For more information, refer to [Insert a Placard on page 14](#).



4. Select **Continue** to view a screen stating that the device setup has completed.

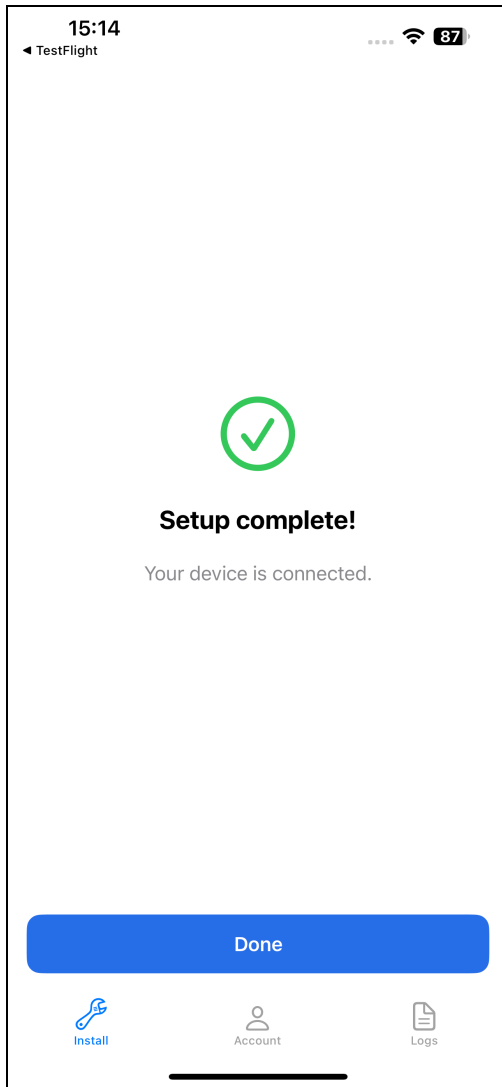

5. Select **Done** to close the app.

Update Firmware

The DSS-100 firmware should always be updated to the latest version. Firmware can be loaded to the DSS-100 via the XiO Cloud service. Additionally, a firmware upgrade can be triggered locally as described in [Local Configuration on page 32](#).

NOTE: Firmware updates can also be loaded to multiple DSS-100 devices at once at the group level in XiO Cloud.

For more information on updating the device firmware in XiO Cloud, refer to the [XiO Cloud User Guide](#).

Local Configuration

Certain device modes and functions can be triggered using the recessed pinhole on the rear of the device. The following table describes each mode or function and its corresponding press-and-hold pattern used to trigger it.

Mode	Pattern	Description
Factory Restore	Press and hold the pinhole for 5 seconds until LEDs turn red.	Restores the device to factory default settings and removes the saved SSID.
Demo Mode	Press and release the pinhole rapidly 4 times.	Enters a demo mode that demonstrates various color, flash, and breathe patterns for the LEDs. Press and release the pinhole while in demo mode to cycle through the various mode states. Power cycle the device to exit demo mode.
Firmware Upgrade	Enter demo mode as described above, and then press and hold the pinhole for 5 seconds until LEDs flash white.	<p>Performs a firmware upgrade for the device if new firmware is available. The device LEDs flash white for the duration of the firmware upgrade.</p> <p>The device must be connected to a Wi-Fi® network to perform a firmware upgrade.</p>
Diagnostic Mode	Press and release the pinhole rapidly 2 times.	<p>Enters a diagnostic mode. If the device is reporting an issue, the LEDs will perform a color and flash pattern that corresponds with the issue.</p> <p>Refer to Troubleshooting on page 35 for a list of all issues and their corresponding LED patterns.</p>

Network Port List

The DSS-100 requires the following external and internal ports to be open while the device is running. These ports are opened by default.

NOTE: Additional ports and domains are required to use the XiO Cloud service. For more information, refer to the [XiO Cloud Service Security Reference Guide](#).

Function	Destination Port	From (Sender)	To (Listener)	Notes
DNS	53/TCP, UDP	Device	DNS Server	DNS services
DHCP	67/UDP	Device	DHCP Server	DHCP addressing
DHCP	68/UDP	DHCP Server	Device	DHCP addressing
NTP	123/UDP	Device	NTP Server	Network Time Protocol (NTP)
HTTPS	443/TCP	Device	XiO Cloud® Service	For XiO Cloud® services. A persistent connection is made via AMQP over WebSockets. HTTPS services such as routing lookups and transfers may be used.
MQTTS	8883/TCP	Device	MQTT Broker	MQTT over TLS

Perform a Factory Restore

If the DSS-100 must be restored to its factory default settings, press and hold the pinhole on the rear of the device for 5 seconds until its LEDs turn red. The factory restore process is initiated immediately.

CAUTION: Performing a factory restore returns all settings to their default values and removes the saved SSID.

Once the DSS-100 restarts after completing the factory restore process, it can be configured as described in [Initial Setup on page 17](#).

Troubleshooting

If the DSS-100 is experiencing an issue, enter diagnostic mode as described in [Local Configuration on page 32](#). The device LEDs will perform a color and flash pattern that corresponds with the issue as described in the table below.

NOTE: For assistance troubleshooting any of the following errors, contact Crestron True Blue support via phone, email, or chat as described at www.crestron.com/Support. Be prepared to provide the LED color and flash pattern performed by the device in diagnostic mode.

Error Code	LED Color/Flash Pattern	Description	Resolution
HYDGN_CURL_MALLOC_ERROR	Red LEDs, 1 flash	Unable to allocate memory for the FirstContact request.	Restart the device (temporary workaround). Upgrade the device firmware manually via the rear pin hole.
HYDGN_CURL_PARAM_ERROR	Yellow LEDs, 1 flash	The parameters sent to the FirstContact request are incorrect.	Upgrade the device firmware manually via the rear pin hole.
HYDGN_CURL_DNS_RESOLVE_ERROR	Blue LEDs, 1 flash	Unable to resolve DNS for the FirstContact server.	Ensure the device network settings are valid.
HYDGN_CURL_CERTIFICATE_ERROR	Red, LEDs, 2 flashes	A certificate issue has occurred when connecting to the FirstContact server URL.	Upgrade the device firmware manually via the rear pin hole.
HYDGN_IOTHUB_SAS_TOKEN_ERROR	Yellow LEDs, 2 flashes	Unable to replenish the SAS token for the XiO Cloud IoT Hub connection.	Contact Crestron support for assistance.
HYDGN_IOTHUB_BAD_CREDENTIAL_ERROR	Blue LEDs, 2 flashes	The keys provided by the FirstContact request to connect to XiO Cloud are invalid.	Contact Crestron support for assistance.
HYDGN_IOTHUB_DEVICE_DISABLED_ERROR	Red LEDs, 3 flashes	The device is disabled from connecting to XiO Cloud.	Contact Crestron support for assistance.
HYDGN_IOTHUB_RETRY_EXPIRED_ERROR	Yellow LEDs, 3 flashes	The maximum number of connection retry attempts has been reached.	Restart the device (temporary workaround). Contact Crestron support for assistance.

Error Code	LED Color/Flash Pattern	Description	Resolution
HYDGN_IOTHUB_NO_NETWORK_ERROR	Blue LEDs, 3 flashes	A network issue is preventing a connection to XiO Cloud.	Ensure the device network settings are valid.
HYDGN_IOTHUB_COMMUNICATION_ERROR	Red LEDs, 4 flashes	The device is unable to communicate with XiO Cloud.	Ensure the device network settings are valid.
HYDGN_IOTHUB_PING_RESPONSE_ERROR	Yellow LEDs, 4 flashes	The device is unable to ping XiO Cloud.	Ensure the device network settings are valid.
HYDGN_IOTHUB_QUOTA_EXCEEDED_ERROR	Blue LEDs, 4 flashes	The device has exceeded its daily quota of connection messages.	Restart the device (temporary workaround). Contact Crestron support for assistance.
HYDGN_FCS_BUILD_FCSREQUEST_ERROR	Red LEDs, 5 flashes	The device is unable to build the request payload to be sent to the FirstContact server.	Upgrade the device firmware manually via the rear pin hole.
HYDGN_FCS_INVALID_URL_ERROR	Yellow LEDs, 5 flashes	An invalid URL has been configured for the FirstContact server.	Contact Crestron support for assistance.
HYDGN_FCS_INVALID_DEVICE_ERROR	Blue LEDs, 5 flashes	A device that has an invalid model (or other properties) is attempting to register with the FirstContact server.	Contact Crestron support for assistance.
HYDGN_FCS_BLOCKED_IN_IOTHUB_ERROR	Red LEDs, 6 flashes	The device has not yet been claimed into an XiO Cloud account.	Claim the device into XiO Cloud as described in Initial Setup on page 17 and then wait 15 minutes.
HYDGN_FCS_GENERIC_ERROR	Yellow LEDs, 6 flashes	A generic failure has occurred from the FirstContact server.	Contact Crestron support for assistance.
HYDGN_IOTHUB_HEARTBEAT_MISS_ERROR	Blue LEDs, 6 flashes	The device is not able to receive a ping response from XiO Cloud.	Restart the device (temporary workaround). Contact Crestron support for assistance.

Resources

The following resources are provided for the DSS-100.

NOTE: You may need to provide your Crestron.com web account credentials when prompted to access some of the following resources.

Crestron Support and Training

- [Crestron True Blue Support](#)
- [Crestron Resource Library](#)
- [Crestron Online Help \(OLH\)](#)
- [Crestron Technical Institute \(CTI\) Portal](#)

Product Certificates

To search for product certificates, refer to the [Product Certificates](#) section of the Crestron Resource Library.

Related Documentation

- [XiO Cloud® Service User Guide](#)

