

Ensō Prime Lenses

USER MANUAL

December 2024 • 1.0 • English

D45 1000 8872



Disclaimer

Before using the product, be sure to read and understand all respective instructions.

The product is available for commercial customers only.

For product specification changes since this document was published, refer to the latest publications of ARRI data sheets or data books, etc., for the most up-to-date specifications.

Not all products and / or types are available in every country. Please check with an ARRI sales representative for availability and additional information.

The information given in this document is subject to change without notice.

While ARRI endeavors to enhance the quality, reliability and safety of their products, customers agree and acknowledge that the possibility of defects thereof cannot be eliminated entirely. To minimize risk of damage to property or injury (including death) to persons arising from defects in the products, customers must incorporate adequate safety measures in their work with the system and have to heed the stated canonic use.

ARRI or its subsidiaries expressly exclude any liability, warranty, demand or other obligation for any claim, representation, or cause, or action, or whatsoever, express or implied, whether in contract or tort, including negligence, or incorporated in terms and conditions, whether by statute, law or otherwise. In no event shall ARRI or its subsidiaries be liable for or have a remedy for recovery of any special, direct, indirect, incidental, or consequential damages, including, but not limited to lost profits, lost savings, lost revenues or economic loss of any kind or for any claim by third party, downtime, good will, damage to or replacement of equipment or property, any cost or recovering of any material or goods associated with the assembly or use of our products, or any other damages or injury of the persons and so on or under any other legal theory.

Neither ARRI nor its subsidiaries assume any liability for infringement of patents, copyrights or other intellectual property rights of third parties by or arising from the use of ARRI products or any other liability arising from the use of such products. No license, express, implied or otherwise, is granted under any patents, copyrights or other intellectual property right of ARRI or others.

In the case one or all of the foregoing clauses are not allowed by applicable law, the fullest extent permissible clauses by applicable law are validated.

Imprint

© 2024 Arnold & Richter Cine Technik GmbH & Co. Betriebs KG. All rights reserved.

The device contains proprietary information of Arnold & Richter Cine Technik GmbH & Co. Betriebs KG; it is provided under a license agreement containing restrictions on use and disclosure and protected by copyright law. Reverse engineering of the software is prohibited.

No part of this publication may be used for distribution, reproduction, transmission, transcription, storage in a data retrieval system, or translated into any language in any form by any means without the prior written permission of Arnold & Richter Cine Technik GmbH & Co. Betriebs KG.

If you are downloading files from our web pages for your personal use, make sure to check for updated versions.

ARRI cannot take any liability whatsoever for downloaded files, as technical data are subject to change without notice.

Due to continued product development the information in this document may change without notice. The information and intellectual property contained herein is confidential between ARRI and the client and remains the exclusive property of ARRI. If you find any problems in the documentation, please report them to us in writing. ARRI does not warrant that this document is flawless.

Original version.

Initial Language

The initial language of this user manual is English. User manuals in other languages are translations from English.

In the event of conflict between the respective languages (i.e. if any translation(s) of present document has/have been prepared for convenience or any other purpose), with regards to the meaning or interpretation of a word or an instruction etc., the contents and provisions of the English language version shall prevail.

For Further Assistance

Arnold & Richter Cine Technik GmbH & Co. Betriebs KG

Herbert-Bayer-Str. 10

D-80807 Munich

Germany

E-mail: service@arri.de

Website: www.arri.com/en/technical-service

Document Revision History

Document ID: D45 1000 8872

Version	Release	Date	Note
1.0		December 2024	First release

Content

1	About This Document	7
1.1	Product Information Resources	7
1.2	How to Use This Manual	7
1.3	Intended Use	8
2	About This Product	9
2.1	ARRI Ensō Prime Lenses and Ensō Vintage Elements	9
2.2	ARRI Ensō Prime Layout	10
2.3	ARRI Ensō Vintage Elements Layout	11
2.4	Contents of ARRI Ensō Prime Core Set	11
2.5	Identification of Ensō Prime Lenses	12
2.6	Identification of Ensō Vintage Elements	12
3	Safety Instructions	14
3.1	Safety Conventions and Product Labels	14
3.2	General Safety Instructions	15
3.3	Certifications and Safety Standards	15
4	Mounting and Operation	16
4.1	LPL Mount	16
4.2	To Mount the Lens	17
4.3	Magnetic Holding System	17
4.4	Front Rings for Ensō Prime 10.5 mm and 14 mm	18
4.5	Lens Support	19
4.6	Ensō Extender 1.4x and 2.0x Installation	20
4.7	Focus and Iris Ring	21
5	LDS-2 Lens Metadata	23
6	Technical Data	24
6.1	Ensō Prime Lenses	24
6.2	Ensō Vintage Elements	27
7	Use of ARRI Ensō Vintage Elements with ARRI Cameras and Lenses	28
7.1	Compatibility Information	28
7.2	Handling of In-camera Filter of LPL Mount for ARRI ALEXA	29
8	Shimming and Compensation for Ensō Vintage Elements	31
8.1	Shimming of LPL Mount	32
8.2	Lens Metadata and Shimming of LDS Contact Block	32
8.3	Shimming Tools	34
8.4	How to Use the Torque Screwdriver	34
8.5	Shimming Procedure	36
9	Ensō Creative Adapter	38
9.1	Preparation of Filters for the Ensō Creative Adapter	38
9.2	Set up of the Ensō Creative Adapter	39
10	Velcro Tabs	41
10.1	Components of a Velcro Tab	41

10.2 To Attach Velcro Tabs.....	41
10.3 To Remove Velcro Tabs	42
11 Cleaning	43
11.1 Recommended Cleaning Agents	43
11.2 Cleaning Procedure for Lenses.....	44
11.3 Cleaning Procedure for Storage Cases	44
12 Transportation, Storage and Disposal	45
12.1 Transportation	45
12.2 Storage.....	46
12.3 Storage Boxes.....	48
13 Spare Parts	49
14 Product Range of Ensō Lenses and Ensō Vintage Elements	50
14.1 Technical Drawings Ensō Prime Lenses.pdf.....	54
15 ARRI Service Contacts	70

1 About This Document

This user manual contains detailed information about the features and functionalities of the device. Please visit the website <http://www.arri.com> to download the operating manual, where applicable, and much more information about this and other ARRI products.

Keep all manuals and all other operating and assembly instructions belonging to the device in a safe place for future reference and possible subsequent owners

For useful information in addition to these manuals please have a look at the [ARRI learn & help](#) section on the [ARRI website](#).

The ARRI Academy courses provide unrivalled insights into the full possibilities of working with ARRI camera systems, lenses, lighting systems and accessories.

Our advanced service training courses are designed to transfer detailed knowledge about how to service and repair all types of ARRI products and give you permanent access to detailed service instructions, special tools and service parts. To learn more, please visit [ARRI academy](#) or contact academy@arri.de.

1.1 Product Information Resources

The ARRI documentation portal provides important documents on the product for free download.

Please enter the following searchkeys in the search bar to retrieve the documents for the product:

Ensō Prime Lenses

[ARRI documentation portal](#)



For more details about the product, please refer to the ARRI website at:

[Ensō Prime Lenses](#)



1.2 How to Use This Manual

All directions are given from an operators point of view. For example, lens right side refers to the right side of the lens when standing behind the camera and operating it in a normal fashion.

Connectors are written in all capital letters, for example "LPL".

This manual contains furthermore useful reference material including the technical specifications and dimensional drawings.

1.3 Intended Use

ARRI Ensō Prime Lenses and Ensō Vintage Elements are a range of professional lenses and accessories for cameras.



NOTICE

All versions of the Ensō Prime Lenses and its accessories are intended exclusively for professional use. It shall be used only by skilled and trained personnel. The product and its accessories shall not be used by inexperienced users and without proper training.

Read and understand the user manual before use.

Use the product and its accessories only for the purpose described in this document. Always follow the safety instructions and system requirements for all equipment involved. ARRI assumes no liability for damages or changes that are caused by improper use. You are not allowed to modify the product and its accessories.

2 About This Product

2.1 ARRI Ensō Prime Lenses and Ensō Vintage Elements

ARRI introduces its new series of Ensō Prime Lenses, reaching beyond the company's traditional market to embrace corporate and commercial content creators and owner-operators at earlier stages of their careers. Small, portable, and versatile, Ensō Prime Lenses deliver exceptional images in almost any condition. The beautifully smooth and balanced native look can be tuned with Ensō Vintage Elements, which attach to the back of the lenses, allowing many different looks to be achieved with a single, cost-effective lens set.

Ensō Prime Lenses combine German precision engineering with Japanese optical excellence. Simplicity and purity of purpose were guiding design principles and inspired the name Ensō, after the circular Zen calligraphy symbol. Creating an Ensō with a single brushstroke is an expression of nowness that requires emptying one's mind of distractions and fully committing to the creative flow. ARRI Ensō Prime Lenses embody this philosophy by instilling the confidence to put aside technical concerns and focus on capturing the moment.



Whether on a conventionally lit set or on fast-moving, lower-tier productions shot by small crews with minimal lighting, Ensō Prime Lenses can be relied upon to produce engaging, well-controlled images. It is this complete dependability in any shooting environment, combined with ARRI's legendary build quality and climatic tolerances, that gives users the freedom to forget about technical worries and respond to their surroundings with unfettered creativity.

Close focus is a stand-out feature of ARRI Ensō Prime Lenses, with an impressive magnification ratio of 1:4 on most focal lengths, equivalent to 10" close focus on the 32 mm, which is only 3.7" from the front element. This facilitates beautiful close-up work, for example on product or food shoots, and the minimized breathing means focus racks have no discernible impact on framing. Stunning bokeh and fall-off round out the lenses' emotive focus characteristics.

Great care has been taken to balance the many optical parameters defining the native Ensō look, which is sharp and true, yet gentle and natural. But for projects that require a different look, ARRI provides the Ensō Vintage Elements—interchangeable optics that attach magnetically to the back of Ensō Prime Lenses. Far exceeding the scope of conventional filters, they offer quick and easy external lens tuning that incrementally shifts the look and feel of images.

Building on what ARRI has learned from feedback about its Impression Filters for Signature lenses, Ensō Vintage Elements incorporate significant advantages. They come in more powerful strengths, producing images that are sharper in the center and therefore easier to focus, but with a stronger de-tuned effect at the edges of frame. They have encoded chips that convey metadata about shifts of focal length, T-stop, and focus, and from there to on-set monitors and postproduction. Focus scale changes caused by the Elements can even be compensated for automatically with the ARRI Hi-5 and Hi-5 SX hand unit, whether crews decide to use the included lens shims or not.

The full kit of six Vintage Elements comes as standard with ARRI's core set of six Ensō Prime Lenses. It includes three positive Vintage Elements of different strengths, producing smeary, soft-edged bokeh in the background and Petzval-like image swirl at the corners of frame. The three negative Vintage Elements have the opposite effect; out-of-focus background highlights have dark centers and bright outlines that overlap to create an edgier, more energetic feel. The kit also

includes an Ensō Creative Adapter, which lets users invent their own unique Elements for personalized external lens tuning. It comes with three retaining rings that allow different thicknesses of glass or other material to be used and held securely.

Packing exceptional optical performance into a diminutive form factor, Ensō Prime Lenses are compact, lightweight, and portable, making them fast and easy to work with on set. Gear rings are in the same position on all 14 of the Ensō focal lengths, most of which are T2.1 and have a front diameter of 95 mm, so they can be changed on the camera without disruption. The focal lengths in the core set will be the most frequently used, but the wide-angle 10.5 and 14 mm, as well as the telephoto 250 mm (350/500 mm with its included 1.4x/2x Extenders) allow Ensō cinematographers to meet even the most extreme visual demands.

ARRI Ensō Prime Lenses have been designed and priced to appeal to a wide range of image-makers, no matter where they are in their creative journeys. Choosing Ensōs is about making a safe, long-term investment in lenses that will be versatile and trustworthy career companions. Putting ARRI quality within the reach of corporate shoots, documentaries, and commercials that do not have large budgets or crews, Ensō Prime Lenses empowers their users, allowing them to develop, grow, and go with the creative flow.

2.2 ARRI Ensō Prime Layout

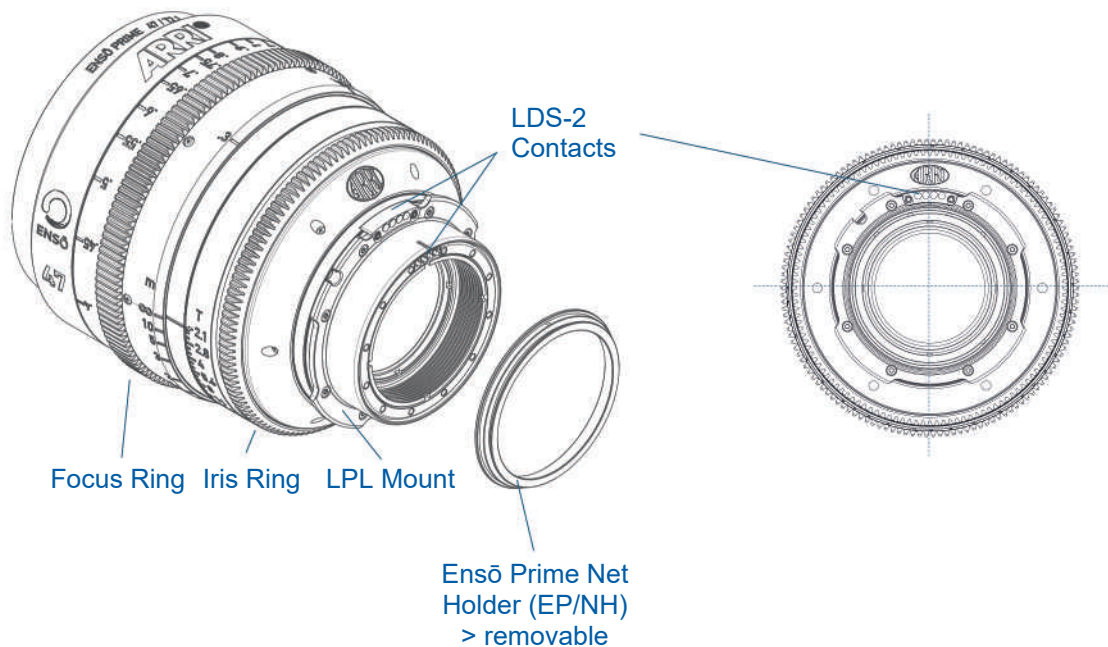

2.3 ARRI Ensō Vintage Elements Layout

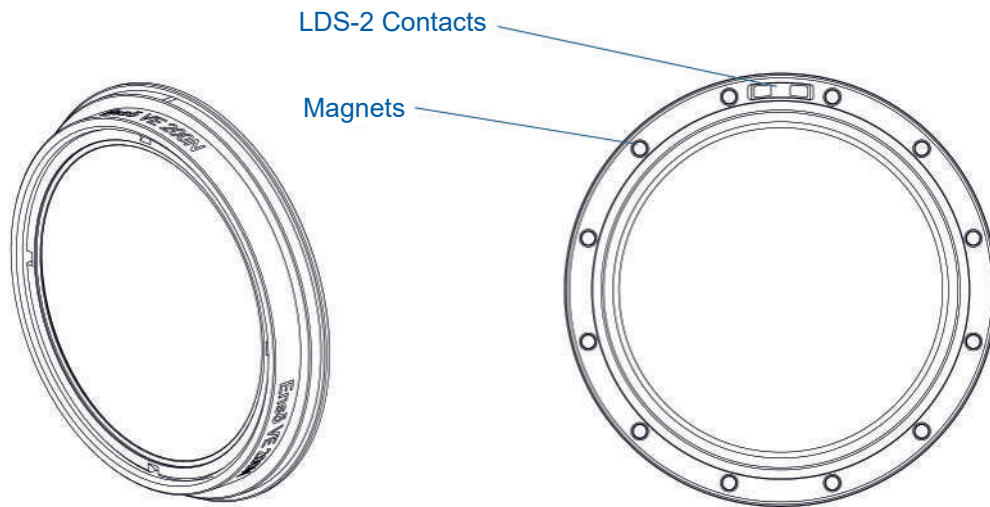

2.4 Contents of ARRI Ensō Prime Core Set

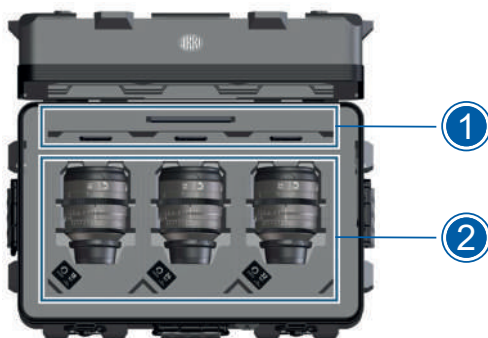

- 1 1x Ensō Welcome Pack
1x Optical Cleaning Cloth
2x Velcro Tab – Ensō Prime 18/T2.1
2x Velcro Tab – Ensō Prime 24/T2.1
2x Velcro Tab – Ensō Prime 32/T2.1
- 2 1x ARRI Ensō Prime 18/T2.1
1x ARRI Ensō Prime 24/T2.1
1x ARRI Ensō Prime 32/T2.1

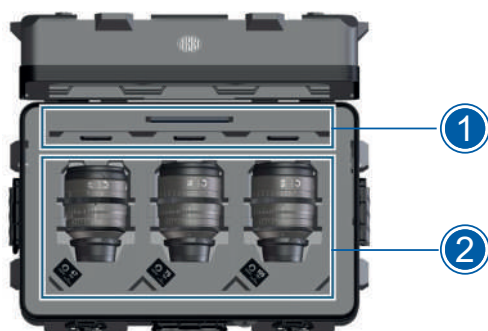

- 1 1x Ensō Welcome Pack
1x Optical Cleaning Cloth
2x Velcro Tab – Ensō Prime 47/T2.1
2x Velcro Tab – Ensō Prime 75/T2.1
2x Velcro Tab – Ensō Prime 105/T2.1
- 2 1x ARRI Ensō Prime 47/T2.1
1x ARRI Ensō Prime 75/T2.1
1x ARRI Ensō Prime 105/T2.1

2. Global Trade Item Number (GTIN) / Bar code / Data Matrix Code:
The product GTIN number is placed on a sticker at the bottom of the filter storage box as clear text, data matrix code and barcode as well following the international GS1 standard. The GS1 barcode or data matrix code can be scanned with appropriate barcode scanners. The encoded information of ARRI's GS1 GTIN code differs from the usual ARRI product barcode labels.

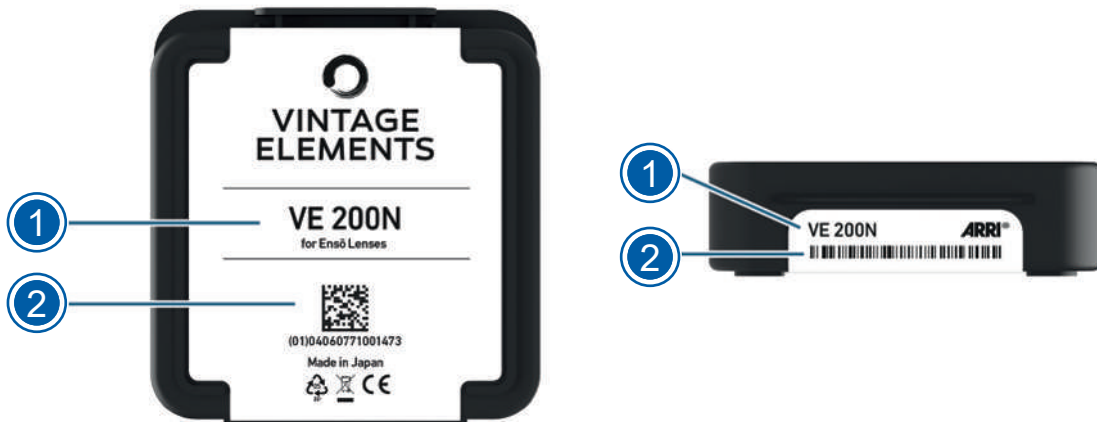

Identification of Ensō Vintage Elements Type

The Ensō Vintage Elements type is engraved into the ring of the rear magnetic holder. This can be seen in the picture below using Ensō VE 200N.

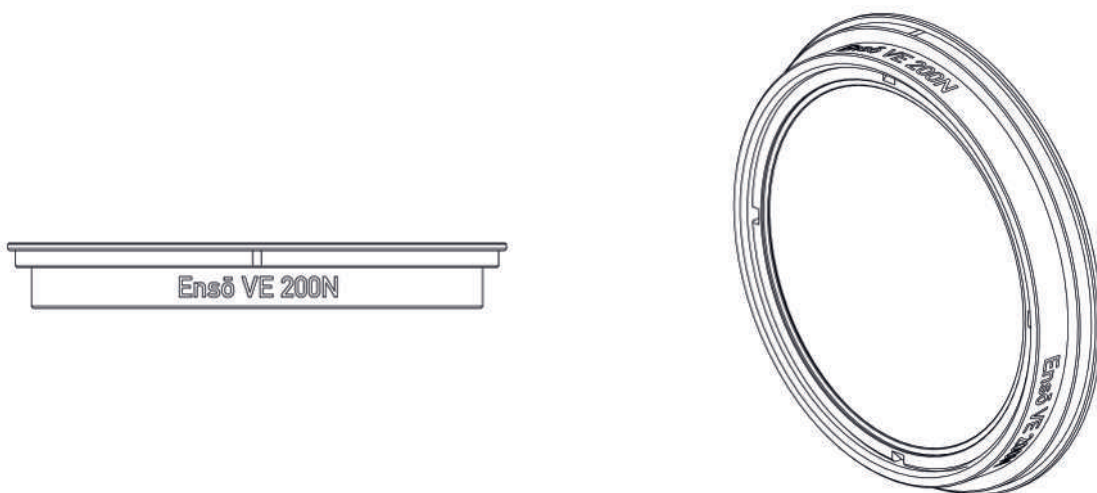

The nomenclature of the filters is as follows:

- Ensō VE = Ensō Vintage Element
- 200 = Diopter strength (200 = 2.0 diopters)
- N = Diopter type (P = Positive, N = Negative)

3 Safety Instructions

3.1 Safety Conventions and Product Labels

These instructions use safety instructions, warning symbols and signal words to draw your attention to different levels of risk:



WARNING

WARNING indicates a possibly imminent danger. If not avoided death or serious injury may result.

Always follow the recommended measures to avoid this potentially hazardous situation.



CAUTION

CAUTION indicates a potentially imminent danger. If not avoided, slight or minor injuries may result.

Always follow the recommended measures to avoid this potentially hazardous situation.



NOTICE

NOTICE indicates a potentially harmful situation. If not avoided, the equipment or something in its surrounding may be damaged.

Always follow the recommended measures to avoid this situation.

HINT

Not relevant to safety, **HINT** provides additional information to clarify or simplify a procedure.

Warning Symbols and Product Labels



General warning sign



Warning of electrical voltage



Warning of hot surfaces



Warning of sharp element



Warning of the risk of crushing



Warning of obstacles on the ground



Please read all instructions carefully before using the product for the first time.



Direct Current symbol found on electronics requiring or producing DC power.

3.2 General Safety Instructions



CAUTION

High Energy Light Sources

Permanent damage to the eyes and the lens and/or the camera sensor.

- ▶ Do not point the lens or camera into direct sunlight, very bright light sources or high energy light sources (e.g. laser beams).



CAUTION

General Precautions when Handling Lenses

Risk of damage.

- ▶ Do not remove any safety measures from the system.
- ▶ Do not operate the system in areas with humidity above operating levels, expose it to water or moisture!
- ▶ Do not subject the lens to severe shocks.
- ▶ Never insert objects of any kind into any part of the lens unless not clearly qualified in this manual.
- ▶ Do not remove any paint marked screws.
- ▶ Change rear elements only in a dry and dust-free environment. If this is not possible, take extra care that no dust enters the camera while the lens is off.
- ▶ Follow the cleaning instructions in this manual to avoid damage of the lens and rear elements.
- ▶ Do not use any strong or aggressive cleaning detergents like Methanol, Acetone, Benzine, or acids, as they may damage the optical coating or mount.



NOTICE

Protective Caps and Changing a Lens

Keep the protective caps on the lens when not mounted to the camera or not in operation. Dirt and dust particles can settle on the lenses. Particles on the lenses can later be visible in the recordings made by the camera.

- ▶ Change camera lenses only in a dry and dust-free environment. If this is not possible, take extra care that no dust enters the camera while the lens is off
- ▶ Contact ARRI Service to examine the lens and/or camera if undefined spots show in the image.

3.3 Certifications and Safety Standards

ARRI is committed to providing our customers with safe and environmentally friendly products that are compliant with the European Union RoHS and the European Union REACH regulation.

4.2 To Mount the Lens

Before you mount a lens to or remove a lens from the camera, read the Safety Instructions [▶ 14]. To mount a lens:

1. Remove the rear cap of the lens.
2. Make sure the rear element of the lens is clean.
3. If the rear part of the lens is not installed with other rear elements, the Ensō Prime Net Holder should always be attached.
4. On the camera side, turn the bayonet ring anti-clockwise until it stops.
5. Remove the lens port cap from the camera.
6. Carefully insert the lens into the lens port. Align the notch in the lens flange with the index pin on the mount. Lens markings should be visible from either side of the camera.
7. Seat the lens flange flush to the lens mount.
8. Turn the bayonet ring clockwise until the lens is locked securely.
9. Ensure that the lens is properly mounted.



WARNING

Risk of Damage due to Incorrect Mounting Adapter

- ▶ Do not use on PL mount cameras! LPL lenses can only be used on cameras with LPL mounts. Mounts on many ARRI cameras are easily replaced by the user. Contact your local ARRI dealer to obtain the appropriate LPL mount for your camera.
- ▶ Do not use force to mount the lens. Please check that the lens is properly positioned if the lock does not rotate smoothly to the closed position.



CAUTION

- ▶ When not attached to the camera, attach the protective caps to the front and rear of the lens to prevent dust from entering the lens cavity.
- ▶ LPL mount lenses can only be mounted in a certain orientation into the camera (with the LDS-2 contacts in 12 o'clock position).

4.3 Magnetic Holding System

A variety of accessories can be attached to the rear of the lens using the incorporated magnetic holding system. An Ensō Prime Net Holder (EP/NH) is included as a standard part with every Ensō Prime Lens.

1. The Ensō Prime Net Holder incorporates a groove that will hold a small rubber band. Place a net across the face of the holder and gently stretch a rubber band over the net to fit into the groove. Once the rubber band is in place, gently tighten the net as desired and trim the excess. There is a witness mark on the holder that may be used to orient the weave of the net to the lens. A size 12 rubber band yields optimal results.
2. Attach an accessory element to the lens by placing the magnetic face of the accessory against the rear of the lens until it seats firmly. The Net Holder must be mounted with the LDS contacts in the 12 o'clock position to enable LDS functions. Therefore, align the witness mark on the accessory with the witness mark on the lens.
3. Remove an attached accessory by lifting it gently from the rear of the lens. No tools are necessary. Pay attention to pull the lens out in a straight way. Removing it at an angle could result in the rear element being scraped off.

All Ensō Vintage Elements as well as the Ensō Creative Adapter use the same holding system.



NOTICE

- ▶ The lens is designed to be used with an accessory attached, even if it is an empty Ensō Prime Net Holder. The only exception applies when using a lens with the 1.4x or 2.0x Ensō Extender. In this case the Ensō Prime Net Holder, the Ensō Creative Adapter or an Ensō Vintage Element should be moved to the rear of the 1.4x or 2.0x Ensō Extender.
- ▶ Be careful not to touch the rear lens when attaching or removing an accessory of the rear part.
- ▶ If the camera is used in a vertical direction pointing upwards with the Ensō Prime Lens and the accessory attached, the accessory may fall off the Magnetic Rear Filter Adapter in case strong shaking movements or shocks are applied. This could result in damage to the filter.
- ▶ It is not possible to stack multiple Ensō Prime Net Holders, Ensō Creative Adapters or Ensō Vintage Elements.

4.4 Front Rings for Ensō Prime 10.5 mm and 14 mm

The Ensō Prime 10.5 mm and 14 mm lenses feature interchangeable front rings, allowing the lenses to be used with either a 134 mm front ring or a 156 mm front ring. For guidance on which front ring to use with specific camera formats, please refer to the document *Ensō Prime Lenses | Overview of Vignetting Performance* available on our download page.

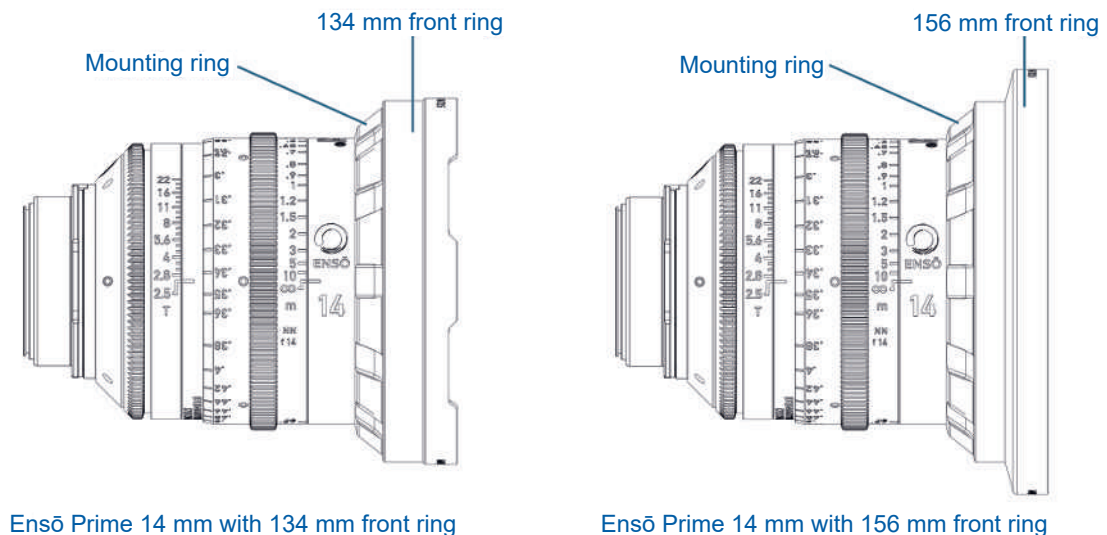

To attach or to remove a front ring

To remove a front ring:

1. Rotate the mounting ring counterclockwise until the front ring has loosened.
2. Detach the front ring from the lens.

To attach a front ring:

1. Identify the notch on the front ring and align it with the small pin located on the lens front surface.
2. Place the front ring carefully onto the lens, ensuring the notch fits around the pin.

3. Rotate the mounting ring clockwise until it is tighten and no further rotation is possible.



Rotate the mounting ring counter-clockwise to un-lock the front ring.



Rotate the mounting ring clockwise to lock the front ring.



⚠ WARNING

Risk of Damage

- ▶ **Do not place the lens face down without a front ring installed.**
Without the front ring, the front element of the lens protrudes and can easily be scratched if placed face down on any surface.
- ▶ **Do not attach a front cap without a front ring installed.**
The front cap will not fit properly and may come into direct contact with the front element, risking damage.

4.5 Lens Support

The Ensō Prime Lens 250 mm may require additional lens support. The lens support guarantees that the weight of the lens will not influence the flange focal depth. It reduces stress on the lens mount.

Before you install the lens, make sure that the lens support is attached properly to the lens. To support a lens, use appropriate rods and lens bridges.

To support a lens:

1. Slide the bridge into position on the rods directly under the lens support ring on the lens.
2. Tighten the lever on its side to fix the bridge.
3. Align and tighten the center screw in the lens support ring, adjusting the height of the center screw with the lever on the back of the lens bridge.

The vertical position of the lens support mount from the optical center of the lens is illustrated below.

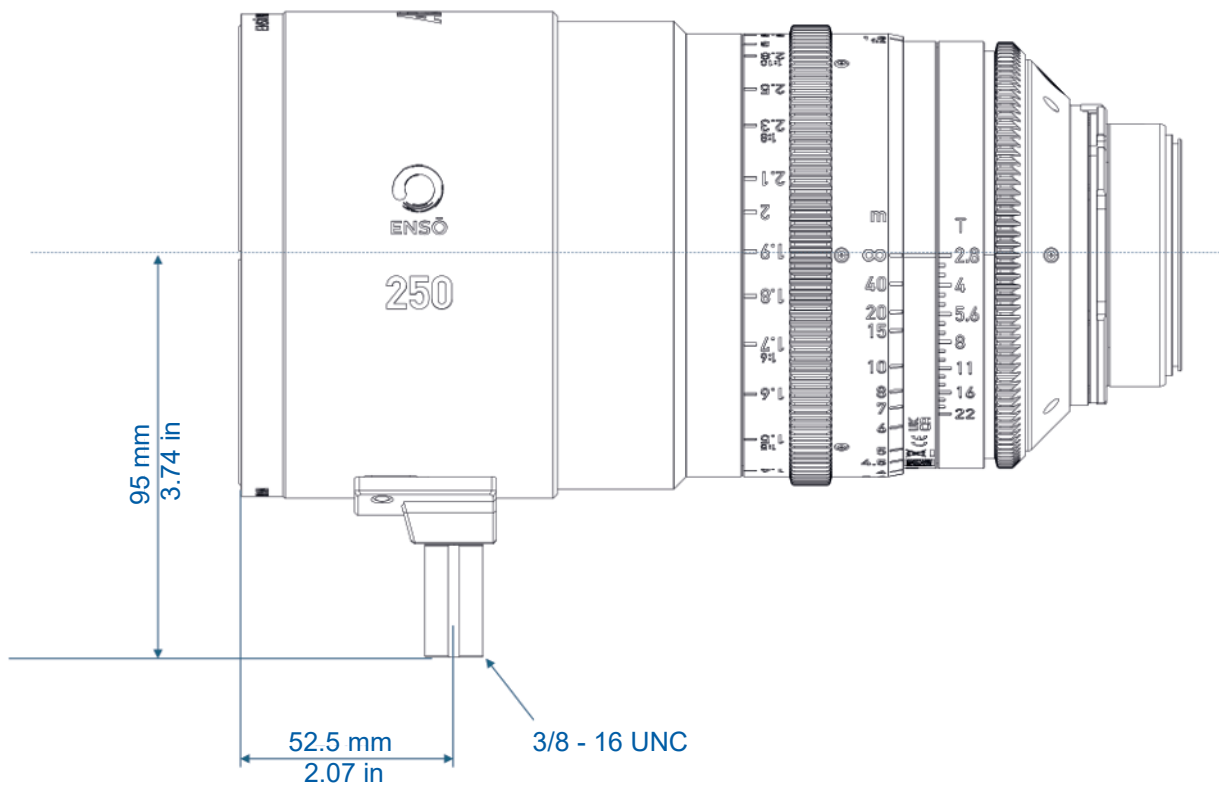

4.6 Ensō Extender 1.4x and 2.0x Installation

Remove the Ensō Prime Net Holder or any other accessory from the rear of the lens. Transfer the accessory to the rear of the 1.4x or 2.0x Ensō Extender for continuity of look, if desired.



WARNING

Risk of Damage

Failure to remove the Ensō Prime Net Holder or any other accessory from the lens will prevent the lens from seating properly. If the accessory contains a glass (such as an Ensō Vintage Element) or plastic element, it may damage the lens, the 1.4x / 2.0x Ensō Extender, and the rear element.

To attach an 1.4x or 2.0x Ensō Extender:

1. Attach the rear of the Ensō Prime Lens to the front of the 1.4x or 2.0x Extender.
2. Ensure that the Ensō Prime Lens is firmly seated and the alignment pin is properly engaged before rotating the LPL locking ring to the closed position.
3. If the LPL locking ring does not close, **DO NOT FORCE**. Ensure that the Ensō Prime Net Holder or any other accessory has been removed.
4. Mount the Ensō Prime Lens and 1.4x or 2.0x Ensō Extender to the camera. Make sure that the lens support is in place and roughly positioned.

To remove an 1.4x or 2.0x Ensō Extender:

1. Reverse this procedure above.

2. Transfer the Ensō Prime Net Holder or any other accessory from the rear of the 1.4x or 2.0x Ensō Extender to the rear of the Ensō Prime Lens.

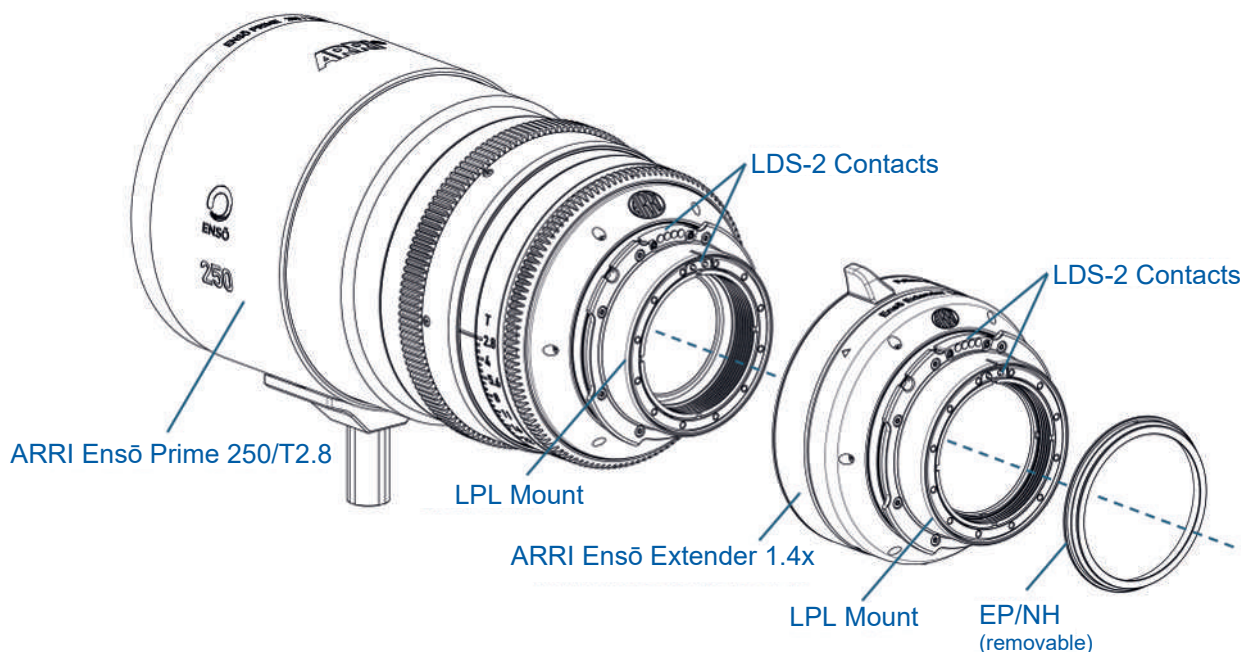

4.7 Focus and Iris Ring

ARRI Ensō Prime Lenses are designed with precise control features to meet the needs of professional film and video production. Below is an explanation of the primary functionalities of the focus and iris rings on Ensō Prime Lenses:

Focus Ring

The focus ring on an Ensō Prime Lens allows for precise manual focus control. Ensō Prime Lenses have a continuous, smooth focus rotation, with a 318° rotation range. Each lens is marked with precise distance indicators (measured in feet or meters) around the focus ring, enabling operators to set focus distance accurately. Furthermore, Ensō Prime Lenses also include additional information about the magnification ratio on the focus scale. Ratios such as 1:10, 1:8, 1:6, 1:5, and 1:4 are engraved into the lens barrel, allowing users to gauge the reproduction size of the subject relative to its actual size. This feature is especially useful in close-up shots, where precise magnification ratios are essential.

Iris Ring (Aperture Control)

The iris ring on an Ensō Prime Lens provides manual control over the aperture, which adjusts the amount of light entering the lens. Ensō Prime Lenses feature a no-click iris ring, meaning the aperture adjustments are smooth and continuous rather than in fixed increments. With continuous control, operators can smoothly change exposure without visible “jumps” in brightness, which is especially useful when transitioning between lighting conditions. Ensō Prime Lenses use T-stop markings instead of f-stops, providing a more accurate measurement of the actual light transmission. This ensures that exposure remains consistent across different lenses with the same T-stop setting.

Standardized Gear Rings

The focus and iris ring are equipped with standard 0.8 MOD gear teeth, allowing it to be connected to a follow focus system. This setup enables the camera operator or focus puller to adjust focus smoothly during filming, even while the camera is in motion. The focus and iris gear rings are positioned in the same locations across all Ensō Prime Lenses, from 10.5mm to 250mm. This standardized placement allows for efficient and quick lens changes on set, as the focus and iris control positions remain consistent across the full lens range. This feature reduces the need to adjust follow focus or iris control setups when switching lenses, ensuring a seamless workflow for filmmakers.

Both the iris and focus scales are readable from both sides of the lens, allowing operators to view settings from either the camera-right or camera-left side. The focus and iris scales are calibrated at ambient temperature. They can be adjusted continuously in the given ranges.



NOTICE

After a long storage period of the lens or exposure to low temperatures, move the focus and iris rings several times before using the lens to ensure proper movement.

5 LDS-2 Lens Metadata

At any given time, ARRI Ensō Prime Lenses provide the camera with metadata that describes the state of the lens. High data rates allow for frame-accurate metadata at high speeds. Absolute encoders eliminate the need for calibration resulting in faster and smoother lens changes. It includes lens serial number, lens distance unit, lens focus distance, lens focal length, lens iris setting, raw encoder information for all axes, and under certain conditions, the lens entrance pupil location. The type of rear element attached to an Ensō Prime Lens is now also part of the lens data that can be read by the camera. This applies to the Ensō Prime Net Holder, all Ensō Vintage Elements and the Ensō Creative Adapter. The type of rear element will be displayed in the GUI of the ALEXA 35 and Hi-5. It will be saved in the clip metadata. In post-production, it is therefore always possible to see which configuration the Ensō Prime Lens was in.

Lens metadata is useful for many applications. It provides camera focal length, focus distance and iris data necessary to reproduce a camera setup for a reshoot. Visual effects compositors use metadata to match perspective when compositing digital elements into a live action scene. Metadata fed to a mixed reality engine facilitates the generation of photo realistic digital backgrounds in real time.

ARRI Ensō Prime Lenses employ the ARRI LDS-2 protocol. Unlike LDS-1, LDS-2 is extensible to meet the changing needs of the motion picture industry and is flexible enough to be used on any camera. If an Ensō Prime Lens is mounted to a camera that only supports the Cooke /i protocol, LDS-2 will detect the new protocol and automatically output Cooke /i compliant metadata.

Occasionally, ARRI will release LDS-2 software updates that add functionality. Your nearest ARRI Service Center can update your lens as necessary.

6 Technical Data

6.1 Ensō Prime Lenses

ARRI Ensō Prime	10.5/T2.8	14/T2.5	18/T2.1	21/T2.1
Optical Parameters				
Focal Length	10.5 mm	14 mm	18 mm	21 mm
T-Stop	T2.8 – T22	T2.5 – T22	T2.1 – T22	T2.1 – T22
MOD from sensor plane (minimum marked distance)	270 mm / 10.5"	270 mm / 10.5"	200 mm / 8"	220 mm / 8.5"
MOD from lens front	80 mm / 3.1"	85 mm / 3.3"	39 mm / 1.5"	69 mm / 2.7"
Magnification ratio at MOD	1:10	1:8	1:4	1:4
Entrance pupil position (related to Image plane, in direction to object plane*)	160,3 mm / 6.3"	151,9 mm / 6"	134,3 mm / 5.3"	131,6 mm / 5.2"
Angle of View H-V-D for LF Open Gate	120,8° / 101,3° / 130°	105,2° / 84,6° / 116°	92,3° / 71,4° / 103,5°	83,2° / 63,3° / 94,4°
Angle of View H-V-D for ALEXA 35 Open Gate	106,5° / 85,1° / 116,9°	89,8° / 68,8° / 100,9°	76,5° / 56,6° / 87,7°	68,2° / 49,6° / 78,8°
Size of Object Field for LF Open Gate	423,4 mm / 294,7 mm / 515,9 mm	342,6 mm / 238,5 mm / 417,5 mm	162,8 mm / 113,3 mm / 198,4 mm	169,2 mm / 117,8 mm / 206,1 mm
Size of Object Field for ALEXA 35 Open Gate	315 mm / 216,3 mm / 382,2 mm	252,7 mm / 173,5 mm / 306,6 mm	119,7 mm / 82,2 mm / 145,1 mm	126,8 mm / 87,1 mm / 153,8 mm
Physical Dimensions				
Front diameter	134 / 156 mm	134 / 156 mm	95 mm	95 mm
Max. housing diameter	134 / 156 mm	134 / 156 mm	104,7 mm / 4.1"	104,7 mm / 4.1"
Length from flange	141 mm / 5.6"	141 mm / 5.6"	117 mm / 4.6"	117 mm / 4.6"
Weight (lens only)	2.3 kg	2.1 kg	1.4 kg	1.4 kg
Lens barrel	Aluminum	Aluminum	Aluminum	Aluminum
Interfaces				
Lens mount	LPL	LPL	LPL	LPL
Lens data system	LDS-2 & Cooke /i	LDS-2 & Cooke /i	LDS-2 & Cooke /i	LDS-2 & Cooke /i
Flange focal distance	44 mm	44 mm	44 mm	44 mm

* The plane 44mm behind the LPL mount flange is referred to as the marked image plane.

ARRI Ensō Prime	24/T2.1	28/T2.1	32/T2.1	40/T2.1
Optical Parameters				
Focal Length	24 mm	28 mm	32 mm	40 mm
T-Stop	T2.1 – T22	T2.1 – T22	T2.1 – T22	T2.1 – T22
MOD from sensor plane (minimum marked distance)	230 mm / 9"	230 mm / 9"	250 mm / 10"	280 mm / 11"
MOD from lens front	69 mm / 2.7"	69 mm / 2.7"	89 mm / 3.5"	119 mm / 4.7"
Magnification ratio at MOD	1:4	1:4	1:4	1:4
Entrance pupil position (related to Image plane, in direction to object plane*)	131,8 mm / 5.2"	118,8 mm / 4.7"	119,5 mm / 4.7"	117,2 mm / 4.6"
Angle of View H-V-D for LF Open Gate	75,2° / 56,4° / 86,1°	66,9° / 49,4° / 77,3°	59,7° / 43,6° / 69,8°	49,6° / 35,6° / 58,7°
Angle of View H-V-D for ALEXA 35 Open Gate	60,9° / 43,9° / 71,0°	53,5° / 38,1° / 62,9°	47,3° / 33,5° / 55,9°	38,8° / 27,1° / 46,3°

ARRI Ensō Prime	24/T2.1	28/T2.1	32/T2.1	40/T2.1
Size of Object Field for LF Open Gate	157,5 mm / 109,7 mm / 191,9 mm	146,1 mm / 101,7 mm / 177,9 mm	156,5 mm / 109,0 mm / 190,7 mm	152,6 mm / 106,2 mm / 185,9 mm
Size of Object Field for ALEXA 35 Open Gate	119,4 mm / 82,0 mm / 144,8 mm	110,1 mm / 75,6 mm / 133,6 mm	117,5 mm / 80,7 mm / 142,5 mm	115,9 mm / 79,6 mm / 140,6 mm
Physical Dimensions				
Front diameter	95 mm	95 mm	95 mm	95 mm
Max. housing diameter	104,7 mm / 4.1"	104,7 mm / 4.1"	104,7 mm / 4.1"	104,7 mm / 4.1"
Length from flange	117 mm / 4.6"	117 mm / 4.6"	117 mm / 4.6"	117 mm / 4.6"
Weight (lens only)	1.4 kg	1.5 kg	1.4 kg	1.3 kg
Lens barrel	Aluminum	Aluminum	Aluminum	Aluminum
Interfaces				
Lens mount	LPL	LPL	LPL	LPL
Lens data system	LDS-2 & Cooke /i	LDS-2 & Cooke /i	LDS-2 & Cooke /i	LDS-2 & Cooke /i
Flange focal distance	44 mm	44 mm	44 mm	44 mm

* The plane 44mm behind the LPL mount flange is referred to as the marked image plane.

ARRI Ensō Prime	47/T2.1	58/T2.1	75/T2.1	105/T2.1
Optical Parameters				
Focal Length	47 mm	58 mm	75 mm	105 mm
T-Stop	T2.1 – T22	T2.1 – T22	T2.1 – T22	T2.1 – T22
MOD from sensor plane (minimum marked distance)	320 mm / 12.5"	360 mm / 14"	430 mm / 17"	590 mm / 23.5"
MOD from lens front	159 mm / 6.3"	199 mm / 7.8"	263 mm / 9.3"	423 mm / 16.7"
Magnification ratio at MOD	1:4	1:4	1:4	1:4
Entrance pupil position (related to Image plane, in direction to object plane*)	124,5 mm / 4.9"	115,6 mm / 4.6"	119,9 mm / 4.7"	122,7 mm / 4.8"
Angle of View H-V-D for LF Open Gate	42,8° / 30,5° / 51,1°	35,1° / 24,8° / 42,1°	27,6° / 19,4° / 33,4°	19,8° / 13,9° / 23,9°
Angle of View H-V-D for ALEXA 35 Open Gate	33,3° / 23,1° / 39,9°	27,2° / 18,8° / 32,6°	21,2° / 14,6° / 25,6°	15,2° / 10,5° / 18,3°
Size of Object Field for LF Open Gate	149,5 mm / 104,1 mm / 182,2 mm	151,6 mm / 105,5 mm / 184,7 mm	151,4 mm / 105,4 mm / 184,4 mm	150,0 mm / 104,6 mm / 182,2 mm
Size of Object Field for ALEXA 35 Open Gate	113,5 mm / 78,0 mm / 137,7 mm	115,1 mm / 79,0 mm / 139,6 mm	114,7 mm / 78,7 mm / 139,1 mm	114,6 mm / 78,8 mm / 138,9 mm
Physical Dimensions				
Front diameter	95 mm	95 mm	95 mm	95 mm
Max. housing diameter	104,7 mm / 4.1"	104,7 mm / 4.1"	104,7 mm / 4.1"	104,7 mm / 4.1"
Length from flange	117 mm / 4.6"	117 mm / 4.6"	123 mm / 4.8"	123 mm / 4.8"
Weight (lens only)	1.3 kg	1.5 kg	1.5 kg	1.6 kg
Lens barrel	Aluminum	Aluminum	Aluminum	Aluminum
Interfaces				
Lens mount	LPL	LPL	LPL	LPL
Lens data system	LDS-2 & Cooke /i	LDS-2 & Cooke /i	LDS-2 & Cooke /i	LDS-2 & Cooke /i
Flange focal distance	44 mm	44 mm	44 mm	44 mm

* The plane 44mm behind the LPL mount flange is referred to as the marked image plane.

ARRI Ensō Prime	150/T2.5	250/T2.8	250/T2.8 1.4x Extender	250/T2.8 2.0x Extender
Optical Parameters				
Focal Length	150 mm	250 mm	350 mm	500 mm
T-Stop	T2.5 – T22	T2.8 – T22	T4 – T22	T5.8 – T22
MOD from sensor plane (minimum marked distance)	770 mm / 30.5"	1300 mm / 4'2"	1334 mm / 4'4.5"	1344 mm / 4'4.9"
MOD from lens front	574 mm / 22.6"	1049 mm / 3'5"	1049 mm / 3'5"	1049 mm / 3'5"
Magnification ratio at MOD	1:4	1:4	1:2.9	1:2
Entrance pupil position (related to image plane, in direction to object plane*)	131,5 mm / 5.2"	128,3 mm / 5.1"	161,0 mm / 6.3"	172,8 mm / 6.8"
Angle of View H-V-D for LF Open Gate	13,9° / 9,7° / 16,9°	8,4° / 5,9° / 10,2°	6° / 4,2° / 7,3°	4,2° / 2,9° / 5,1°
Angle of View H-V-D for ALEXA 35 Open Gate	10,6° / 7,3° / 12,9°	6,4° / 4,4° / 7,7°	4,6° / 3,1° / 5,6°	3,2° / 2,2° / 3,9°
Size of Object Field for LF Open Gate	148,4 mm / 103,3 mm / 180,6 mm	155,3 mm / 108,5 mm / 188,7 mm	111,9 mm / 77,8 mm / 136,2 mm	78,3 mm / 54,5 mm / 95,3 mm
Size of Object Field for ALEXA 35 Open Gate	113,2 mm / 77,8 mm / 137,3 mm	118,8 mm / 81,8 mm / 143,9 mm	85,3 mm / 58,6 mm / 103,5 mm	56,7 mm / 41,0 mm / 72,5 mm
Physical Dimensions				
Front diameter	95 mm	114 mm	114 mm	114 mm
Max. housing diameter	104,7 mm / 4.1"	115 mm / 4.5"	115 mm / 4.5"	115 mm / 4.5"
Length from flange	152 mm / 6"	207 mm / 8.1"	241 mm / 9.5'	251 mm / 9.9"
Weight (lens only)	1.9 kg	2.9 kg	3.5 kg	3.6 kg
Lens barrel	Aluminum	Aluminum	Aluminum	Aluminum
Interfaces				
Lens mount	LPL	LPL	LPL	LPL
Lens data system	LDS-2 & Cooke /i	LDS-2 & Cooke /i	LDS-2 & Cooke /i	LDS-2 & Cooke /i
Flange focal distance	44 mm	44 mm	44 mm	44 mm

* The plane 44mm behind the LPL mount flange is referred to as the marked image plane.

6.2 Ensō Vintage Elements

Focal length, image circle and T-stop change

When using Ensō Vintage Elements with Ensō Prime Lenses, some basic parameters of the lens system will change. Like a „weak extender “, the focal length of the base lens as well as the size of the projected image and the aperture will change. The factors are given in the following table.

	Focal Length multiplier	Image circle multiplier	T-stop multiplier	Exposure change (stops)	Open aperture
VE 350N	1.099	1.099	1.099	-0.28	2.31
VE 200N	1.063	1.063	1.063	-0.17	2.23
VE 100N	1.03	1.03	1.03	-0.08	2.16
No Filter	1.000	1.000	1.000	0.00	2.1
VE 100P	0.979	0.979	0.979	0.06	2.06
VE 200P	0.959	0.959	0.959	0.13	2.01
VE 350P	0.934	0.934	0.934	0.2	1.96

As an example, you will find a calculation of the influenced optical parameters based on the following lens configuration below:

- Lens: Ensō Prime Lens 35 mm @ T2.1
- Ensō Vintage Element: VE 350P

The results when using the lens configuration from above is as follows:

- Resulting focal length: $35 \text{ mm} * 0.934 = 33,25 \text{ mm}$
- Resulting T-Stop: $T2.1 * 0,934 = T1.96$



With the next SUP of ALEXA 35 and Hi-5 it will be possible to reflect these changes in the camera overlay as well as in the recorded clip metadata. The camera or the Hi-5 will compensate for the above-mentioned changes and display the correct values for focal length and T-stop.

7 Use of ARRI Ensō Vintage Elements with ARRI Cameras and Lenses

7.1 Compatibility Information

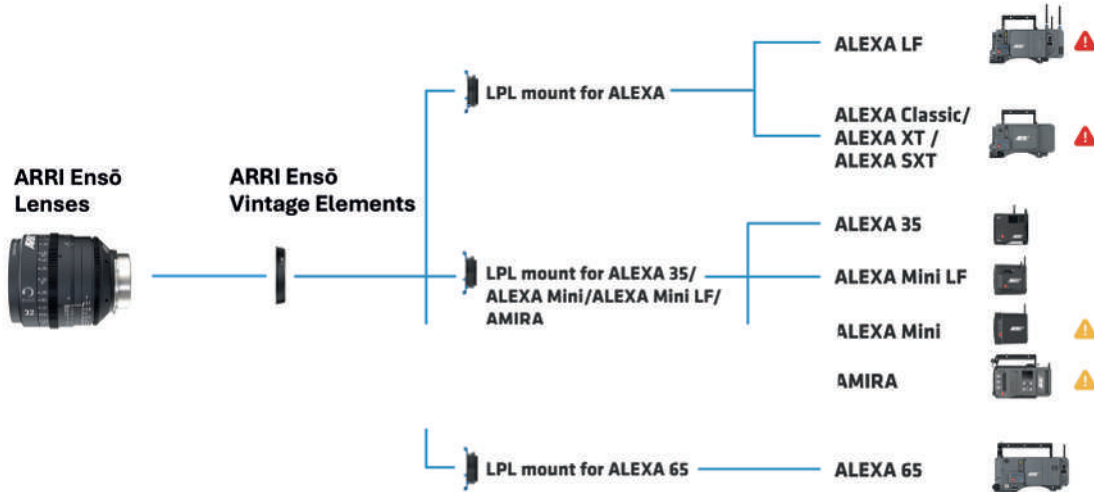
As illustrated in the compatibility chart below, ARRI Ensō Vintage Elements can basically be used with all ARRI camera systems. However, for some camera models important precautions must be taken to ensure compatibility.



-  An Ensō lens with an attached Ensō Vintage Element can only be mounted to an ALEXA LF or ALEXA Classic / ALEXA XT / ALEXA SXT if the In-Camera Filter Module (IFM) is removed from the LPL Mount.
-  An Ensō lens with an attached Ensō Vintage Element can only be mounted to an ALEXA Mini or AMIRA if the camera has been converted for use with Leica M-Mount lenses. For further information regarding the conversion, please contact an ARRI service center.
-  The compatibility of 3rd party cameras and adapters needs to be checked.

ALEXA 35, ALEXA Mini LF & ALEXA 65

No adjustments are needed. An Ensō Prime Lens with an attached Ensō Vintage Element can be mounted to the camera without any concerns.

ALEXA LF, ALEXA Classic, ALEXA XT, ALEXA SXT

It is important to verify whether the filter position in the LPL lens mount is occupied by the LF IFM Filter Frame. An Ensō Prime Lens with an attached Ensō Vintage Element can only be mounted to the camera if the filter frame is removed. Please see chapter 7.2 for a detailed explanation on how to remove and insert the in-camera filter of the LPL Mount for ALEXA cameras.



CAUTION

Failure to remove the in-camera filter from the LPL lens mount will prevent the lens from seating properly and may damage the in-camera filter and the Ensō Vintage Element.

ALEXA Mini, AMIRA

An Ensō Prime Lens with an attached Ensō Vintage Element can only be mounted to an ALEXA Mini or AMIRA if the camera has been converted for use with Leica M-Mount lenses. For further information regarding the conversion, please contact the ARRI service center.



⚠ CAUTION

A use of an ALEXA Mini or AMIRA which is not converted for use with Leica M-Mount lenses will prevent the lens from seating properly and may damage the Ensō Vintage Element.

7.2 Handling of In-camera Filter of LPL Mount for ARRI ALEXA

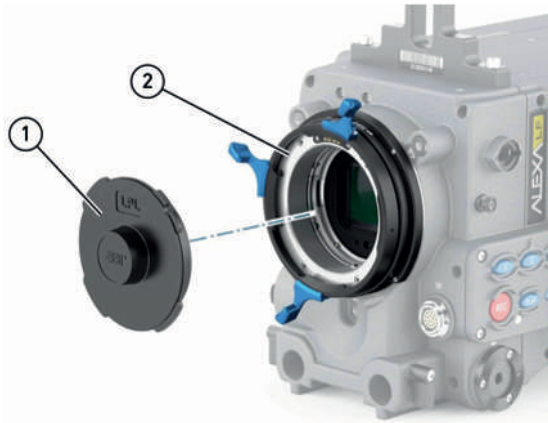

- Remove the lens or lid (1) from the LPL lens mount (2).

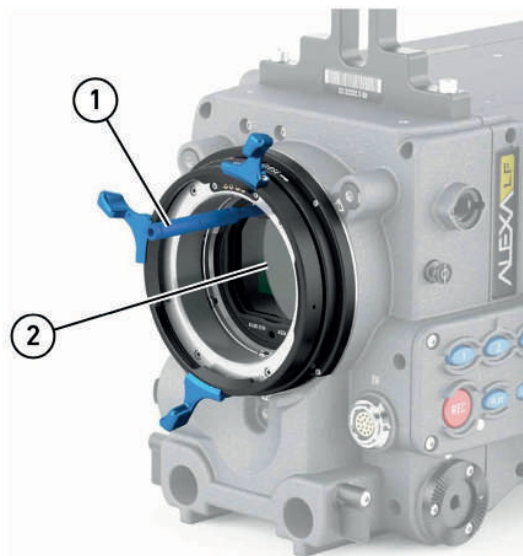

- Carefully screw the filter insertion tool (1) into the filter ring's (2) thread hole in the 12 o'clock position (1).

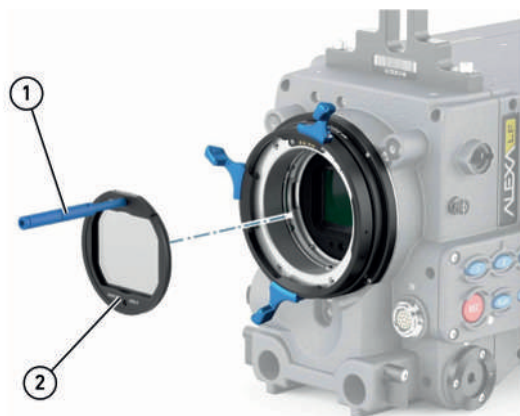

- Pull the filter (2) from the bottom ring in the camera's LPL mount. If the filter position is held by an LF IFM Empty Filter Frame, remove it likewise.
- Clean the removed filter and stow it properly in its individual box and the storage case. If the filter position was held by an LF IFM Empty Filter Frame, store it likewise.
- Place the removed filter into its padded filter box in the storage case. Remove the filter insertion tool.

Insertion of In-camera Filter

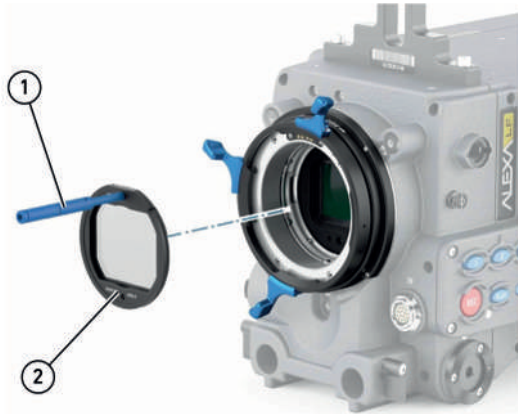

- Make sure the filter (2) is clean and the filter insertion tool is in the 12 o'clock position (1).

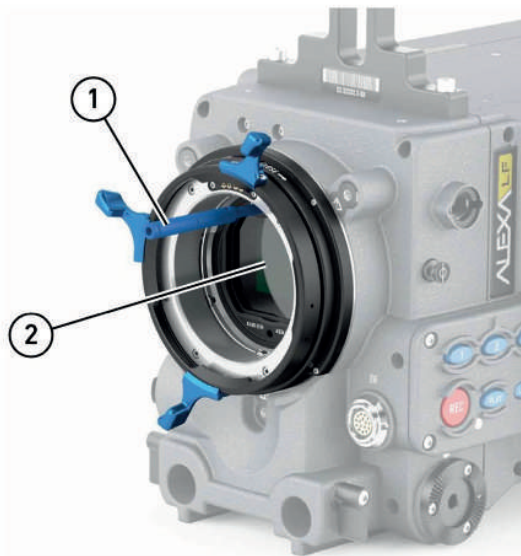

- Place the next filter onto the bottom ring in the camera's LPL mount. The filter insertion tool must be in the 12 o'clock position (1).
- Align the filter ring's main notch with the bottom ring's red nut in the 6 o'clock position. To ensure an accurate fit, align the filter ring's other notches with the two red noses in the bottom ring's 10:30 and 1:30 positions.
- Put your finger on the lower edge of the filter ring and push the filter ring slightly inwards, using the filter insertion tool on top and your finger on the bottom.
- After the filter ring has audibly snapped into position, carefully unscrew the filter insertion tool. The filter shall sit precisely on the bottom ring.
- Mount a lens (observe maximum lens dimensions!) or cover the LPL lens mount properly with its lid.

8 Shimming and Compensation for Ensō Vintage Elements

As mentioned in chapter 6.2, some basic parameters of the lens system will change when Ensō Vintage Elements are used together with Ensō Prime Lenses. Besides the changes to the focal length and the T-stop, also the focus position will change depending on which Vintage Element is used at which T-stop. These focus shifts primarily happen with negative Vintage Elements, and at T-stops that are significantly different from T2.1.

In the past, a proper shimming of the lens was necessary in order to compensate for those focus shifts. Otherwise, the lens information provided via LDS-2 would deliver inaccurate focus values. However, with the next SUP of the ALEXA 35 and Hi-5, ARRI introduces a new feature which is called “Diopter Compensation”.

This feature makes it possible to display correct focus, iris and focal length information on the camera and the connected hand units even if the lens is not properly shimmed according to the technical guidelines. This feature helps to simplify the workflow with Ensō Vintage Elements on set and may produce stronger looks than if the lens is properly shimmed.

Nevertheless, of course you can also go the other way and shim the lens according to the technical specifications. Below you will find a simple guideline that you can use to assess in which cases you need to shim.

Positive ARRI Ensō Vintage Elements (VE 100P, VE 200P, VE 350P)



NOTICE

Please note that the use of any positive Vintage Elements (VE 100P, VE 200P, VE 350P) at open aperture (T2.1) doesn't require any shimming. There are no changes to the focus position which means that the physical focus scales on the lens remain accurate as well.

T-Stop at T2.1: No Shimming is required

- Physical Focus Scale Ring on lens remains accurate

T-Stops other than T2.1: Shimming is optional

- Option 1: Lens is shimmed according to guidelines mentioned in Shimming of LPL Mount [▶ 32].
 - Physical Focus Scale Ring on lens remains accurate.
- Option 2: Lens is not shimmed as specified in Shimming of LPL Mount [▶ 32]
 - Electronic Focus Shift Compensation can be activated
 - ALEXA 35 / Hi-5 do display correct compensated focus, iris and focal length information.
 - Physical Focus Scale Ring on lens will be wrong.

Negative ARRI Ensō Vintage Elements (VE 100N, VE 200N, VE 350N):



NOTICE

Please note that the use of any negative Vintage Elements (VE 100P, VE 200P, VE 350P) at open aperture (T2.1) requires the same shim with a thickness of 3 mm. Changing between the different negative Vintage Elements works with focus scales remaining accurate.

T-Stop T2.1 – T22: Shimming of 3 mm is required

- Option 1: Lens is shimmed according to guidelines mentioned in Shimming of LPL Mount [▶ 32]
 - Physical Focus Scale Ring on Lens remains accurate
- Option 2: Lens is not shimmed as specified in Shimming of LPL Mount [▶ 32]
 - Electronic Focus Shift Compensation can be activated
 - ALEXA 35 / Hi-5 do display correct compensated focus, iris and focal length information.
 - Physical Focus Scale Ring on Lens will be wrong.

8.1 Shimming of LPL Mount



CAUTION

- ▶ When removing the LPL mount you will find the previously installed shims underneath. It is advisable to mark these shims to make returning to the original configuration easier. The pre-installed shims must remain on the lens.
- ▶ If Ensō Vintage Elements are used in combination with a 1.4x or 2.0x Ensō Extender, please make sure to shim the mount of the 1.4x or 2.0x Ensō Extender instead of the LPL mount of the lens.

T-stop	Negative Diopter Filters			Positive Diopter Filters		
	VE 100N	VE 200N	VE 350N	VE 100P	VE 200P	VE 350P
T2.1	3.0			Shimming not necessary		
T2 1/3 (T2.24)	3.0	2.98	2.98	/	/	0.025
T2 2/3 (T2.52)	2.99	2.95	2.96	0.025	0.03	0.04
T2.8	2.98	2.93	2.95	0.03	0.05	0.075
T2.8 1/3 (T3.17)	2.96	2.91	2.94	0.03	0.075	0.08
T2.8 2/3 (T3.56)	2.93	2.9	2.93	0.04	0.075	0.1
T4.0	2.91	2.89	2.93	0.05	0.08	0.125
T4.0 1/3 (T4.49)	2.89	2.88	2.93	0.05	0.1	0.13
T4.0 2/3 (T5.04)	2.88	2.87	2.92	0.05	0.1	0.14
T5.6	2.87	2.87	2.92	0.075	0.1	0.15

All given shim thicknesses are in mm.



NOTICE

Please note that the shim thicknesses shown in this table are averaged values based on a preselected number of measured reference lenses. Even though all Ensō Prime Lenses as well as all Ensō Vintage Elements are manufactured to highest quality standards with minimal manufacturing tolerances, the shim thicknesses might vary slightly depending on which lens is used.

8.2 Lens Metadata and Shimming of LDS Contact Block

If only the LPL mount shim 3 mm is used without any further individual shims, the lens will pass meta data when the provided LDS shim 2.925 mm is used.

However, if the lens is shimmed individually for the use at T-stops other than T2.1, in some cases an individual 0.1 mm LDS shim needs to be applied to ensure a stable connection between the LDS terminals of the lens mount and the LDS terminals of the LPL mount.

The recess of the LDS contact block from the mount surface must have a gap of maximum 0,3 mm (see image below). If this is not the case, no LDS data will be transferred from the lens to the camera!



The table below gives an overview in which cases LDS shims need to be attached to the LDS contact block and in which cases no shimming is required.

T-stop	Negative Diopter Filters			Positive Diopter Filters		
	VE 100N	VE 200N	VE 350N	VE 100P	VE 200P	VE 350P
T2.1	2.925 mm LDS Shim (part of Ensō Vintage Elements Shim Set)			No Shimming Necessary		
T2 1/3 (T2.24)						
T2 2/3 (T2.52)						
T2.8						
T2.8 1/3 (T3.17)						
T2.8 2/3 (T3.56)						
T4.0						
T4.0 1/3 (T4.49)						
T4.0 2/3 (T5.04)						
T5.6						

8.3 Shimming Tools

Ensō Vintage Elements Shim Set

Adjustable torque screwdriver with Torx bit TX6x65

Individual Shims (in case Ensō Vintage Elements shall be used at T-stops other than T 2.1)



3x LPL Mount Shim (3 mm)
3x LDS Shim (2.925 mm)

Individual shims need to be purchased separately. Please see the material numbers listed below:

Included in ARRI Ensō Vintage Elements Kit

Not included in ARRI Ensō Vintage Elements Kit

- LPL Mount Shims:**
 50.0020238 - Shim Set*:
 50.0019928, Shim 0.025 mm
 50.0019923, Shim 0.03 mm
 50.0019925, Shim 0.04 mm
 50.0019926, Shim 0.05 mm
 50.0019929, Shim 0.1 mm
 50.0019920, Shim 0.2 mm
 50.0019924, Shim 0.3 mm
 *Each shim type can be ordered separately as well.

- LDS-Shim**
 K5.59474.0, LDS-Shim 0.1 mm

8.4 How to Use the Torque Screwdriver

Insertion of the bit into the bit hole of the screwdriver



Adjustable torque screwdriver with Torx bit TX6x65

Remove the screwdriver and bit from the ARRI Ensō Vintage Elements case.



Torx bit Bit hole

Mount the bit into the end of the screwdriver, ensuring that the bit is fully inserted.

Adjust the Correct Torque

Hold the fluted part of the adjusting ring with your fingers and turn the locking ring counterclockwise to unlock it.

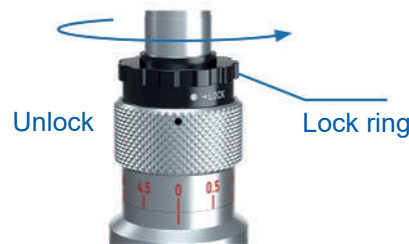

The unit of the torque is displayed in centinewton meter (cN*m). The required torque values you need to set to tighten the screws of the LPL mount and the LDS contact block are listed below. They are repeated inside the upper lid of the box of the Ensō Vintage Elements Shim Set.

	Unit	
	N*m	cN*m
LPL Mount LDS Contact Block	0.1 Nm	10 cNm
LPL Mount	0.5 Nm	50 cNm

Turn the adjusting ring to set the torque value. The torque value of the screwdriver can be calculated the following way:

Torque value = Value of main scale + value of adjusting ring scale

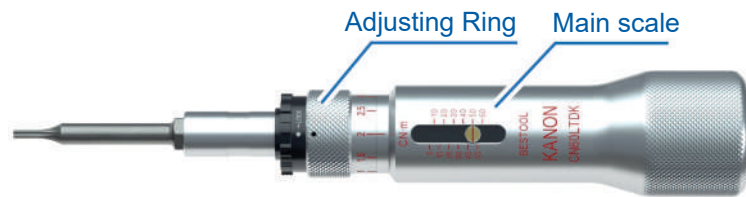

The screwdriver displayed above shows the following torque:

Torque value = 50 cNm + 2 cNm = 52 cNm (0.52 Nm)

Hold the adjusting ring with your fingers and turn the locking ring clockwise to fix the torque value.



Correct use of the torque screwdriver

Align the shank axis of the screwdriver with the axis of the screw before tightening.

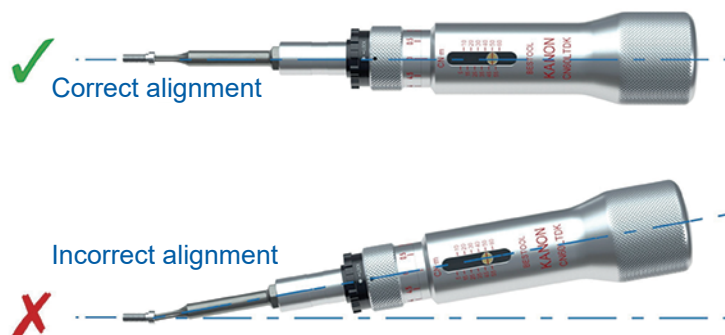

Hold the handle firmly and turn the screwdriver clockwise to tighten the screws completely. Tightening is complete when the screwdriver slips, and you feel a click and hear a click sound. The torque value will not change even if you continue to turn the driver to let it slip again.

Removal of the bit from the screwdriver

Hold the main body of the screwdriver with one hand and pull the bit out of the bit hole of the screwdriver with the other hand.

8.5 Shimming Prodecure

- Remove the rear lens cap.
- Remove the LPL mount:
 - Use the adjustable torque screwdriver to remove the 8 Torx screws of the LPL mount.
 - Carefully lift the mount from the lens.

⚠ CAUTION



- ▶ You will find the previously installed shim underneath. It is advisable to mark this shim to make returning to the original configuration easier. The pre-installed shim must remain on the lens.
- ▶ Please note that these screws shall be used for re-assembly when the LPL mount shim is attached. There is no need to replace the screws with longer screws.
- ▶ If Ensō Vintage Elements are used in combination with a 1.4x or 2.0x Ensō Extender, please make sure to shim the mount of the 1.4x or 2.0x Ensō Extender instead of the LPL mount.

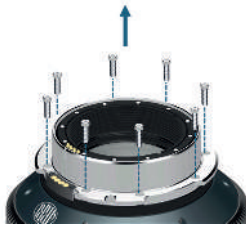

- Select the correct LPL mount shim(s) depending on the T-stop and the Vintage Element which shall be used. Please see the table in chapter 7.1 for further information regarding required shim thicknesses.
- Add the appropriate LPL mount shim(s) to the lens and carefully slide the mount back to the lens.

⚠ CAUTION



Ensure that the shims do not cover the screw holes, otherwise they will be damaged by the screws.

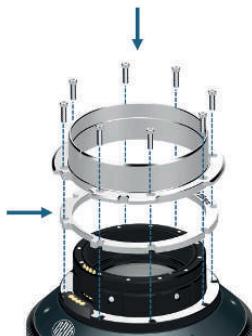

- Please be aware that for tightening the screws a special torque of **0.5 Nm / 50 cNm** must be applied. Use the adjustable torque screwdriver to tighten the 8 TX6 screws of the LPL mount.

⚠ CAUTION



Applying the wrong torque can damage the lens!

- ▶ Make sure that you always tighten opposite screws instead of tightening in a sequence.



- Use the adjustable torque screwdriver to remove the 2 Torx screws of the LDS contact block.



⚠ CAUTION

- ▶ You will find the previously installed shim underneath. It is advisable to mark this shim to make returning to the original configuration easier. The pre-installed shim must remain on the lens.
- ▶ If Ensō Vintage Elements are used in combination with a 1.4x or 2.0x Ensō Extender, please make sure to shim the mount of the 1.4x or 2.0x Ensō Extender instead of the LPL mount.
- ▶ Please note that these screws shall be used for re-assembly when the LDS shim is attached.

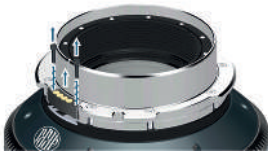

- Add the appropriate LDS shims to the lens.



⚠ CAUTION

- ▶ Handle the thinner shims particularly careful as they can easily kink or tear which makes them unusable.
- ▶ Ensure that the shims do not cover the screw holes, otherwise they will be damaged by the screws.

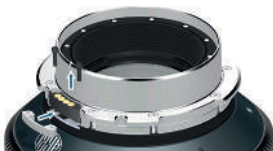

- Tighten the LDS contact block. Please be aware that for tightening the screws a special torque of **0.1 Nm / 10 cNm** must be applied. Use the adjustable screwdriver to tighten the 2 Torx screws of the LDS contact block.



⚠ CAUTION

Applying the wrong torque can damage the LDS contact block!

- ▶ Please use the existing screws of the LDS contact block for this procedure.

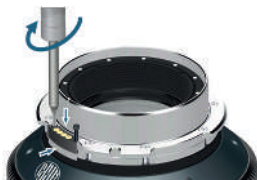

9 Ensō Creative Adapter

The Ensō Creative Adapter is designed to give filmmakers an unprecedented level of creative flexibility with their Ensō lenses. Just like the Ensō Prime Net Holder or Ensō Vintage Elements, the Creative Adapter attaches seamlessly to the back of an Ensō lens, allowing users to expand their visual storytelling toolkit with ease. However, what sets the Ensō Creative Adapter apart is its ability to accommodate nearly any material you choose—from fabric and nets to custom glass elements or Kodak Wratten filters. With compatibility for materials ranging in thickness from 0.1 to 4.8 mm, this adapter enables you to customize your shots with limitless possibilities.

This manual will guide you through the process of setting up the Ensō Creative Adapter, ensuring you get the best results every time. To start, you will need three key components:

- (1) The **Ensō Creative Adapter** (stored in a separate box)
- (2) The **Ensō Retaining Rings** (stored in a separate box)
- (3) The **Ensō Retaining Ring Tool** (stored in a dedicated foam insert)

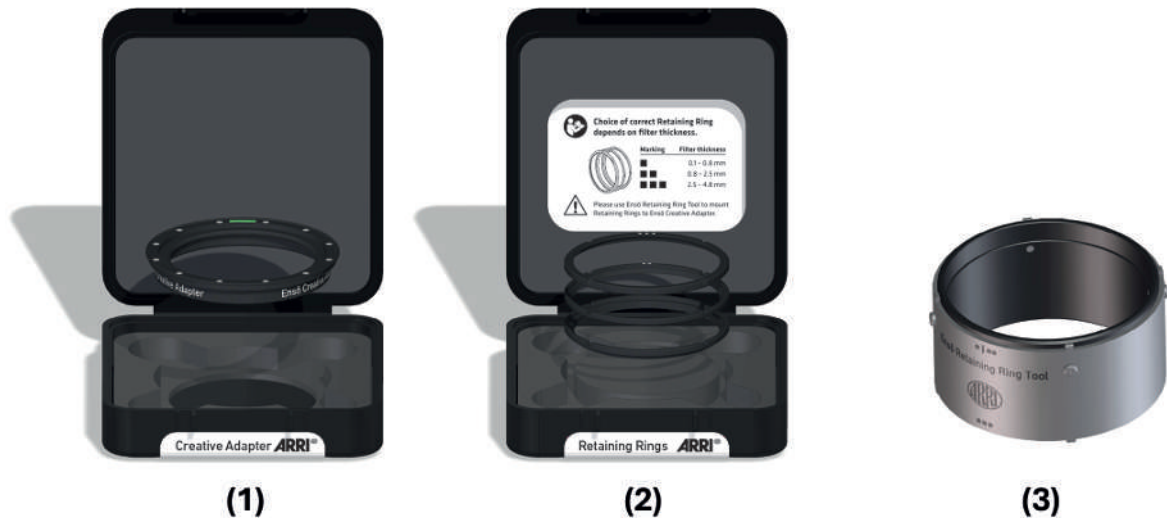

9.1 Preparation of Filters for the Ensō Creative Adapter

To prepare a material for use with the Ensō Creative Adapter, begin by selecting a filter or material that complements your creative vision. You can use various types, including Lee filters, Kodak Wratten filters, gel filters, textured fabrics, nets, glass, or plastic elements—virtually any material that adds the desired effect to your shot. Ensure the filter is cut to a diameter of 46.5 mm / 1.83 in to fit precisely within the adapter. For best results, confirm that the material thickness is between 0.1 and 4.8 mm, so it will secure properly with the appropriate Retaining Ring.

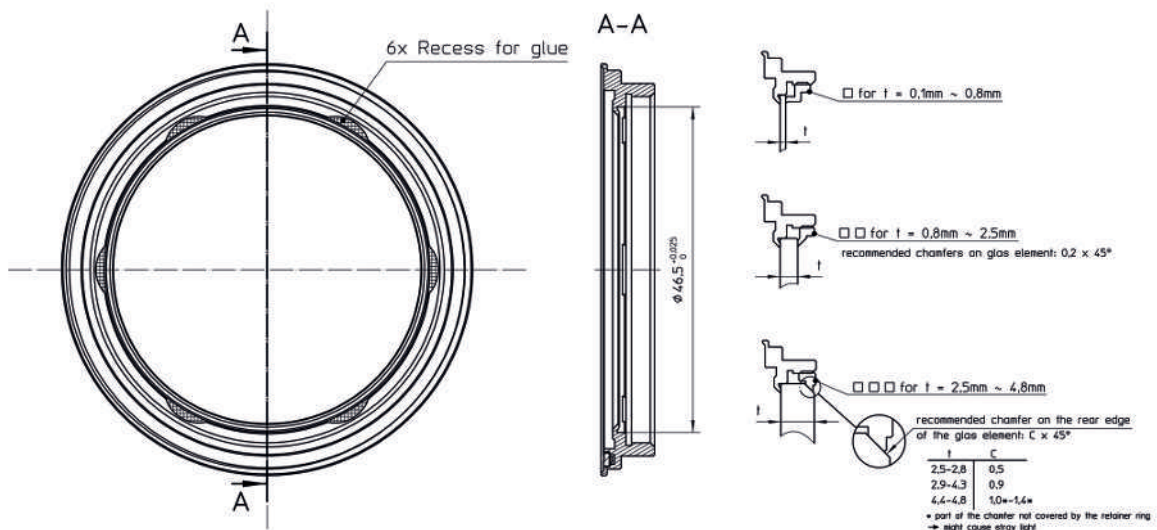

9.2 Set up of the Ensō Creative Adapter

To secure a fabric or filter material into your Ensō Creative Adapter, follow these steps carefully. Ensuring the correct Retaining Ring and orientation will make setup smooth and prevent issues when removing the ring later.

Step 1: Select the Appropriate Retaining Ring

1. Determine the Thickness of Your Material:
Measure the thickness of the material you wish to insert into the Ensō Creative Adapter.
2. Choose the Correct Retaining Ring
Depending on the thickness, select one of the three provided Retaining Rings to securely hold the material in place. Each Retaining Ring is marked with white dots to help you quickly identify the correct one:
 - 1 Dot – For materials between 0.1 - 0.8 mm in thickness
 - 2 Dots – For materials between 0.8 - 2.5 mm in thickness
 - 3 Dots – For materials between 2.5 - 4.8 mm in thickness

NOTICE! An information sticker inside the plastic box holding the Retaining Rings provides this guide as a quick reference.



Step 2: Prepare the Retaining Ring Tool

The **Ensō Retaining Ring Tool** is a specialized tool designed for securely fastening the Retaining Rings onto the Ensō Creative Adapter. It features distinct nubs on each side, with each nub shape tailored to fit specific Retaining Rings. The top side of the tool is intended for Retaining Rings marked with one or two dots, while the bottom side fits the three-dot Retaining Ring. To make identification straightforward, dot markings are laser-etched on both sides of the tool, matching the markings on the corresponding Retaining Rings. This allows for quick selection of the correct side and ensures a secure fit for each ring.



Step 3: Secure the Material

1. Place the Material in the Ensō Creative Adapter.
Center your material within the adapter.

2. Position the Retaining Ring for Securing.
Orient the Retaining Ring correctly. Ensure that the Retaining Ring's dot marking is facing upward, toward you. This is important because the laser-marked dots and matching tool recesses are on the same side.



⚠ CAUTION

If you place the Retaining Ring with the dot facing down, securing it may make it very difficult to remove later due to the absence of tool recesses on the opposite side.

3. Attach the Retaining Ring with the Tool
Position the Retaining Ring Tool over the Retaining Ring, ensuring it aligns with the recessed areas.
Turn the tool clockwise to carefully screw the Retaining Ring into place. The ring will lock the material securely against the adapter.

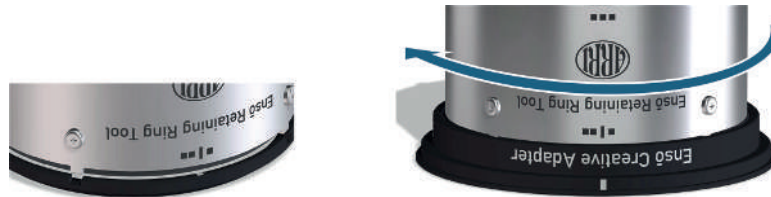

With the Retaining Ring properly secured, the Ensō Creative Adapter is now ready to attach to the lens. To remove the Retaining Ring again, use the tool and carefully turn it counterclockwise.

10 Velcro Tabs

Each Ensō Prime lens is supplied with two Velcro® tabs. A Velcro tab contains essential information specific to an individual Ensō Prime lens, including the focal length, T-stop, and close focus distance. These Velcro tabs are designed to serve as quick-reference labels and are easily attachable to the exterior of lens cases. Their purpose is to streamline lens identification, allowing for efficient access and improved organization on set. The Velcro attachment allows you to move or rearrange labels as needed, making it easy to reorganize lenses during lens swaps or storage adjustments. By visually displaying critical lens details on each case, these tabs reduce setup time and simplify workflow on set. This is especially helpful in fast-paced shooting environments, where quick access to lens information is crucial. Furthermore, all Ensō Vintage Elements Kits will also be supplied with two Velcro® tabs.

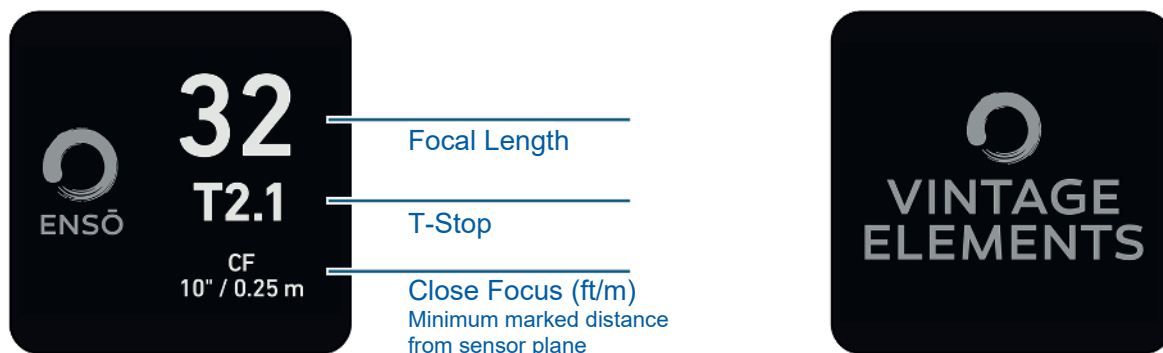

10.1 Components of a Velcro Tab

In general, a Velcro® tab fastener consists of two linear fabric strips which are attached to opposite surfaces to be fixated: one strip is called a hook and the other strip is called the loop fastener.

Hook:

The surface of the hook can be recognized by its rough side featuring lots of tiny hooks. The facing side of the hook is coated with a rigid polyvinyl chloride (PVC) film which contains the essential information as stated above.

Loop:

The surface of the loop can be recognized by its soft side featuring lots of tiny loops. The facing side of the loop contains a tape which is covered with a protective film and shall be used to glue the loop on the desired surface.



Below you will find a description of how to attach and remove the Velcro® tab properly.

10.2 To Attach Velcro Tabs

1. Clean and dry the surface before attaching the tape on the desired surface. Wipe down the surface with a detergent that doesn't leave a film or an oily residue. Otherwise, this may affect the Velcro's ability to adhere. An effective way to clean the surface without leaving behind residues is the use of isopropyl alcohol wipes.
2. Peel off the protective film of the loop and press the tape firmly onto the desired surface. Be careful not to touch the sticky side as this might affect the adhesiveness of the Velcro®.

3. You can attach the hook of the Velcro[®] strip onto the loop right away. Just keep in mind that the Velcro[®] adhesive base needs 24 hours to achieve its strongest adhesion. If you are concerned about the glue coming loose, wait at least one day before attaching and removing hooks from the loop.



CAUTION

- ▶ Avoid caustic cleaning agents such as Methanol, Acetone, Benzine, or acids as they may damage the storage case!
- ▶ Self-adhesive Velcro[®] strips don't stick as well when you peel them off and try to reuse them.
- ▶ Please note that these tapes are not recommended for fabrics, dashboards, flexible vinyl or use underwater. Continued exposure to full sunlight can also damage the fastener.



10.3 To Remove Velcro Tabs

1. Detach the hook from the Velcro[®] tab.
2. Pull the corner of the loop up as much as possible with one hand, while holding the case to which the loop is attached with your other hand.
3. Take the corner of the loop and slowly pull it off the case from top to bottom.
4. Clean the surface with the help of isopropyl alcohol wipes to ensure that no residues are left behind.



CAUTION

Avoid caustic cleaning agents such as Methanol, Acetone, Benzine, or acids as they may damage the storage case!

11 Cleaning

ARRI Ensō Prime Lenses and ARRI Ensō Vintage Elements are precision optics carefully designed to meet the demanding artistic and technical needs of cinematographers at every level of production. For optimal and predictable results, it is crucial to keep your optics clean. Depending on the environment, dust, and non-volatile residuals from cleaning agents, etc., may deteriorate the optical performance significantly. Although the optical coatings of the ARRI Ensō Prime Lenses and ARRI Ensō Vintage Elements have been designed to be robust, it is recommended to follow the common rules of handling precision optics proposed in this manual.



CAUTION

Risk of Damage

- ▶ Avoid touching optical surfaces!
- ▶ Apply blown air to optical surfaces prior to dusting. Deionized air will improve dusting efficiency if particles or optical surfaces are electrostatically charged.
- ▶ Avoid compressed air from cans as droplets of propellant may contaminate optical surfaces and prove difficult to remove. Use oil-free compressed air with less than 2 atm of pressure and equipped with a particle filter in a clean environment.
- ▶ Avoid wiping optical surfaces with a dry tissue or cloth. Use a damp cloth with an appropriate cleaning agent (see below).
- ▶ Use clean, lint-free, and soft single-use paper-based optics cleaning tissues/pads or ARRI Optics Cleaning Cloth (Small 170 x 150mm, Order Number: 50.0019066; Large 14.6" x 17.7", Order Number: K2.0016922). Avoid abrasive particle contamination of your cleaning supplies and cloths (e.g., by sand).
- ▶ Always wipe gently in a single direction and take a new tissue for each stroke if using disposable tissues.



NOTICE

- ▶ Have your equipment ready before starting the cleaning process.
- ▶ To determine the level of contamination, use a bright lamp or bright daylight and change the angle of view of the surfaces from normal to grazing incidence.
- ▶ Always clean the barrel surface or the frame/mount first.
- ▶ When cleaning mounted optics or frames, avoid that cleaning agents are drawn into narrow spaces near the retaining rings, etc., due to capillary forces. Use moistened, but not soaking wet tissues.
- ▶ Use manual air blowers and clean antistatic brushes.
- ▶ Place the lens or element on a clean, soft surface or a clean ARRI Optics Cleaning Cloth.
- ▶ It may be difficult to clean an optical surface without streaks and non-volatile residues when the relative humidity exceeds 65%.
- ▶ Always store your filters in the provided cases when not in use. If not stored in a container, store the lens in a clean environment and protective covers to limit contamination.

11.1 Recommended Cleaning Agents

Use cleaning agents suitable for dielectric coated precision optics to avoid streaking, non-volatile residues, or damaging optical elements. Prepare these liquids in spray or drop dispensing bottles:

- A neutral window detergent
- Deionized distilled water
- Spectroscopy grade isopropyl alcohol

Always use these liquids in this sequence when cleaning.

11.2 Cleaning Procedure for Lenses

For minor particle contaminants like dust, pollen, rain residuals, etc., and moderate contaminants like fingerprints or comparable strains:

1. Treat the surface with compressed air to remove dust and lint.
2. If the surface is still not clean, gently brush off residual loose contaminants.
3. Use one dedicated tissue/cloth for each liquid: one for neutral window detergent, one for deionized distilled water, and one for spectroscopy grade isopropyl alcohol. The liquids should be used in this sequence.
4. Using a bright light source, check for cleaning agent residues, streaks, or other contaminants. It is common to breathe carefully on the optical surface and then to gently wipe off the condensed moisture with a soft cloth, e.g., a clean ARRI Optical Cleaning Cloth. If you decide to do so, avoid saliva droplets on the surface and do not firmly wipe dry parts of the optical surface. If the surface is still not clean, repeat the cleaning sequence.



CAUTION

Avoid caustic cleaning agents such as Methanol, Acetone, Benzine, or acids as they may damage the optical coatings or lens barrel!

11.3 Cleaning Procedure for Storage Cases

ARRI Ensō Prime Cases & ARRI Ensō Vintage Elements cases can be cleaned using the following methods:

1. Light stains, finger smudges and water droplets can usually be removed quickly with a soft sponge, water and a mild soap.
2. Oil and mud stains may be removed using a mixture of mild detergent and water applied with a damp cloth. Finish with a dry cloth.



CAUTION

Do not use a brush that could scratch the surface. Never use chemical solvents or solutions such as paint thinner, alkaline electrolyzed water, etc.

12 Transportation, Storage and Disposal

- Keep the protective caps on the lens when not mounted to the camera or not in operation. The rear cap secures the accessory which is attached to the rear part of the lens.
- ARRI Ensō Prime Lenses are delivered in a rugged transportation case. Always store and transport the lenses in the delivered storage cases. The case should always be used when shipping a lens to an ARRI Service Center. Do not submerge the case in water.
- Do not store the lens for long periods of time in places where it may be subject to extreme temperatures, direct sunlight, high humidity, severe vibration, or strong magnetic fields.
- Condensation: When moving the lens from a cool to a warm location or when the lens is used in a damp environment, condensation may form inside the lens port, on glass surfaces, and on internal or external electrical connections. Operating the lenses while condensation is present may result in damage to the equipment. Condensation on the optical components may have a visible effect on the output images. To reduce the risk of condensation, find a warmer storage location. After moving the lens from cool to warm environment, wait for some time for the lens to warm up to the ambient temperature to avoid condensation.
- Long Term Storage: to ensure the longevity and optimal performance of lenses, please follow these guidelines for long-term storage:
 - Storing lenses in a closed case over an extended period is not recommended. Enclosed spaces can trap moisture, which may lead to condensation and mold formation on lens surfaces, potentially damaging the glass and internal components.
 - For ideal storage, keep lenses in a dry, dust-free environment with good air circulation. This will help prevent moisture buildup and protect lenses from mold and mildew.
 - If storing lenses in a closed space is necessary, place silica gel packets inside to absorb excess moisture. Check and replace the packets periodically to maintain effective moisture control.
 - If lenses must remain in a case for an extended time, open the case periodically to allow air exchange and check for any signs of condensation or mold.

12.1 Transportation



NOTICE

Improper Packing and Transportation of Ensō Prime Lenses or Ensō Vintage Elements

Risk of damage to the Ensō Prime Lenses or Ensō Vintage Elements Kit.

- ▶ Follow the specified environmental conditions.
- ▶ Only transport the Ensō Prime Lenses & Ensō Vintage Elements in suitable cases.
- ▶ Follow the instructions for transport and storage in this chapter.

The Ensō Prime Lenses and the Ensō Vintage Elements Kit can be damaged if not transported and stored properly. Please take note of the following guidelines.



NOTICE

Improper Handling of the Ensō Vintage Elements Kit

Risk of damage to the Ensō Vintage Elements Kit.

- ▶ Keep the Ensō Vintage Element off the lens when not mounted to the camera or not in operation to prevent the Element from falling off.
- ▶ Exposing the Vintage Elements to direct sunlight may cause the sun's rays to focus on a surface that may ignite.

The lid of the case must always be closed during transportation and the latches must also be closed in the correct position. Failure to do so may result in damage to the case, the latches or the contents of the case.



12.2 Storage

ARRI recognizes that our lens and filter products are significant long-term investments. ARRI lens & filter cases are designed to protect your investments while remaining practical for everyday use.

High-impact Polyethylene (PE-HD) Cases

ARRI Ensō Prime Lenses and accessories are shipped in two different case sizes, each tailored to ensure optimal protection and organization for your lenses. Below are the guidelines for how each lens or lens kit will be packed.

Case Large for ARRI Ensō Prime Lenses



This case is intended for shipping the following products:

- Set of three Ensō Prime Lenses as part of the Ensō Prime Core Set
- Individual Ensō Prime Lenses:
 - Ensō Prime 10.5 mm
 - Ensō Prime 14 mm
 - Ensō Prime 250 mm + Ensō Extender 1.4x + Ensō Extender 2.0x

Case Small for ARRI Ensō Prime Lenses



This case is intended for shipping the following products:

- Individual Ensō Prime Lenses between 18 – 150 mm
- Ensō Vintage Elements Kit

Latching and Unlatching

- The shape of the cases are designed to protect each latch against side impacts that may damage the mechanism and cause it to loosen.
- Both cases have two twist latches, often referred to as butterfly latches. They work using a rotating cam connected to a straight component known as the slide. The slide has a curved end that rotates along with the cam. The latch's keeper, a flat metal piece similar to the slide, also has a curved edge that helps lock the slide onto the bracket of the case. When the latch is screwed, the slide locks over the bracket, keeping the case securely closed.
- To open the latch, rotate the cam counterclockwise to release the slide, then lift it away from the bracket.
- To close, align the slide over the bracket, press down, and turn the cam clockwise until it locks into place. This will ensure that the latch is fully secured.
- For additional protection each case contains a lead seal hasp for plastic seals and padlocks.



Concept of Foam Insert

Every ARRI case is lined with a two-layer foam insert. A hard foam interior layer holds the contents firmly in place while a soft foam exterior layer absorbs and distributes impact forces.

The foam inserts in the **Case Large for Ensō Prime Lenses** and **Case Small for Ensō Prime Lenses** are designed to securely hold individual lenses while allowing flexibility in configuration. Each lens has its own custom-cut foam insert that can be easily removed from the case when not needed.

For the **Case Large**, only the foam along the edges of the lid and base is permanently affixed, while the individual inserts remain removable. This case can hold up to three inserts at once, making it adaptable for lenses with focal lengths ranging from 18 to 150 mm. All foam inserts have the same exterior dimensions but are custom-fitted to each specific lens size, allowing you to easily switch out inserts depending on the lenses required for your setup.

The **Case NS** follows the same principle but is designed to hold just one lens and a single corresponding foam insert. However, it is compatible with the foam inserts from the **Case Large**, so you can use the same inserts in both cases. This compatibility allows you to transport your lenses with maximum flexibility across both case types.



Foam Inserts for Enso Prime (EP) lenses: EP 18 EP 21 EP 24 EP 28 EP 32 EP 40 EP 47 EP 58 EP 75 EP 105 EP 150

12.3 Storage Boxes

The storage boxes for the Ensō Vintage Elements, as well as for the Ensō Creative Adapter, Retaining Rings and Shim Set all have the same size and opening mechanism. The storage boxes are covered with a sticker indicating the content of the box. Furthermore, all boxes contain a frame on the lid which makes it possible to easily stack different filter boxes.



All boxes dedicated for the storage of Ensō Vintage Elements contain a foam inlay to ensure the save positioning of the filter during transportation. The foam inlay also contains recesses designed to make it easier to remove the filters from the storage box. When inserting the filter in the box, please make sure that the magnetic contacts of the Vintage Elements are facing upwards to insure maximum stability during transportation.



The box for the Ensō Vintage Elements Shim Set also includes a foam insert. However, it is different from the foam insert of the filter storage boxes. The foam inlay is recessed to ensure a stable hold of the various LPL mount shims and it contains recesses to make it easier to remove the shims from the storage box. As shimming has to be performed with different torques you can find an overview of the necessary torques inside the lid.



The same applies to the Ensō Retaining Rings Box. You will also find an overview of when you should use which Retaining Ring for use with the Ensō Creative Adapter.



13 Spare Parts

Please visit our website www.arri.com:

- for product information & data sheets
- for software updates
- to locate your local dealer for Warranty / Repair / Spare part inquiries.

14 Product Range of Ensō Lenses and Ensō Vintage Elements

ARRI Ensō Prime Core Set (F)

K0.0052483

Includes:



1x KK.0049811 ARRI Ensō Prime Kit 18, 24, 32 (F):

- 1x K2.0048082 ARRI Ensō Prime 18/T2.1 F
- 1x K2.0048086 ARRI Ensō Prime 24/T2.1 F
- 1x K2.0048090 ARRI Ensō Prime 32/T2.1 F
- 1x K2.0050482 ARRI Ensō Prime Set Case 18, 24, 32



1x KK.0049813 ARRI Ensō Prime Kit 47, 75, 105 (F):

- 1x K2.0048094 ARRI Ensō Prime 47/T2.1 F
- 1x K2.0048098 ARRI Ensō Prime 75/T2.1 F
- 1x K2.0048101 ARRI Ensō Prime 105/T2.1 F
- 1x K2.0050483 ARRI Ensō Prime Set Case 47, 75, 105



1x KK.0049815 ARRI Ensō Vintage Elements Kit:

- 1x ARRI Ensō VE 100P / VE 200P / VE 350P / VE 100N / VE 200N / VE 350N
- 1x ARRI Ensō Creative Adapter + Retaining Rings
- 1x ARRI Ensō VE Shim Set
- 1x Adjustable Torque Screwdriver
- 1x ARRI Ensō Retaining Ring Tool
- 1x ARRI Ensō Vintage Elements Case

ARRI Ensō Prime Core Set (M)

K0.0052482

Includes:



1x KK.0049812 ARRI Ensō Prime Kit 18, 24, 32 (M):

- 1x K2.0048083 ARRI Ensō Prime 18/T2.1 M
- 1x K2.0048087 ARRI Ensō Prime 24/T2.1 M
- 1x K2.0048091 ARRI Ensō Prime 32/T2.1 M
- 1x K2.0050482 ARRI Ensō Prime Set Case 18, 24, 32



1x KK.0049814 ARRI Ensō Prime Kit 47, 75, 105 (M):

- 1x K2.0048095 ARRI Ensō Prime 47/T2.1 M
- 1x K2.0048100 ARRI Ensō Prime 75/T2.1 M
- 1x K2.0048102 ARRI Ensō Prime 105/T2.1 M
- 1x K2.0050483 ARRI Ensō Prime Set Case 47, 75, 105



1x KK.0049815 ARRI Ensō Vintage Elements Kit:

- 1x ARRI Ensō VE 100P / VE 200P / VE 350P / VE 100N / VE 200N / VE 350N
- 1x ARRI Ensō Creative Adapter + Retaining Rings
- 1x ARRI Ensō VE Shim Set
- 1x Adjustable Torque Screwdriver
- 1x ARRI Ensō Retaining Ring Tool
- 1x ARRI Ensō Vintage Elements Case



ARRI Ensō Prime 10.5/T2.8 F **KK.0053510**

ARRI Ensō Prime 10.5/T2.8 M **KK.0053511**

includes:

- Case Large for ARRI Ensō Prime Lenses
- Front Ring 134 mm
- Front Ring 156 mm



ARRI Ensō Prime 14/T2.5 F **KK.0053516**

ARRI Ensō Prime 14/T2.5 M **KK.0053517**

includes:

- Case Large for ARRI Ensō Prime Lenses
- Front Ring 134 mm
- Front Ring 156 mm



ARRI Ensō Prime 18/T2.1 F **Ensō Prime Core Set**

ARRI Ensō Prime 18/T2.1 M **Ensō Prime Core Set**

Includes:

- Case Small for ARRI Ensō Prime Lenses



ARRI Ensō Prime 21/T2.1 F **KK.0053518**

ARRI Ensō Prime 21/T2.1 M **KK.0053519**

Includes:

- Case Small for ARRI Ensō Prime Lenses



ARRI Ensō Prime 24/T2.1 F **Ensō Prime Core Set**

ARRI Ensō Prime 24/T2.1 M **Ensō Prime Core Set**

Includes:

- Case Small for ARRI Ensō Prime Lenses



ARRI Ensō Prime 28/T2.1 F **KK.0053520**

ARRI Ensō Prime 28/T2.1 M **KK.0053521**

Includes:

- Case Small for ARRI Ensō Prime Lenses



ARRI Ensō Prime 32/T2.1 F **Ensō Prime Core Set**

ARRI Ensō Prime 32/T2.1 M **Ensō Prime Core Set**

Includes:

- Case Small for ARRI Ensō Prime Lenses



ARRI Ensō Prime 40/T2.1 F **KK.0053522**
ARRI Ensō Prime 40/T2.1 M **KK.0053524**
 Includes:
 - Case Small for ARRI Ensō Prime Lenses



ARRI Ensō Prime 47/T2.1 F **Ensō Prime Core Set**
ARRI Ensō Prime 47/T2.1 M **Ensō Prime Core Set**
 Includes:
 - Case Small for ARRI Ensō Prime Lenses



ARRI Ensō Prime 58/T2.1 F **KK.0053525**
ARRI Ensō Prime 58/T2.1 M **KK.0053526**
 Includes:
 - Case Small for ARRI Ensō Prime Lenses



ARRI Ensō Prime 75/T2.1 F **Ensō Prime Core Set**
ARRI Ensō Prime 75/T2.1 M **Ensō Prime Core Set**
 Includes:
 - Case Small for ARRI Ensō Prime Lenses



ARRI Ensō Prime 105/T2.1 F **Ensō Prime Core Set**
ARRI Ensō Prime 105/T2.1 M **Ensō Prime Core Set**
 Includes:
 - Case Small for ARRI Ensō Prime Lenses



ARRI Ensō Prime 150/T2.5 F **KK.0053527**
ARRI Ensō Prime 150/T2.5 M **KK.0053528**
 Includes:
 - Case Small for ARRI Ensō Prime Lenses



ARRI Ensō Prime 250 F Plus **KK.0053520**
ARRI Ensō Prime 250 M Plus **KK.0053521**
 Includes:
 1x ARRI Ensō Prime 250/T2.8
 1x ARRI Ensō Extender 1.4x
 1x ARRI Ensō Extender 2.0x
 1x Case Small for ARRI Ensō Prime Lenses



ARRI Ensō Vintage Elements Kit Ensō Prime Core Set

Includes:

- 1x ARRI Ensō VE 100P
- 1x ARRI Ensō VE 200P
- 1x ARRI Ensō VE 350P
- 1x ARRI Ensō VE 100N
- 1x ARRI Ensō VE 200N
- 1x ARRI Ensō VE 350N
- 1x ARRI Ensō Creative Adapter + Retaining Rings
- 1x ARRI Ensō VE Shim Set
- 1x Adjustable Torque Screwdriver
- 1x ARRI Ensō Retaining Ring Tool
- 1x ARRI Ensō Vintage Elements Case

See also

 [Technical Drawings Ensō Prime Lenses.pdf](#) [▶ 54]

ARRI Ensō Prime – 10.5/T2.8 & 14/T2.5 (with Front Ring 134 mm)



PRIME LENS DIMENSIONS – Version 2024-11

Technical Data are subject to change without notice

Overview

Exchangeable Front Ring

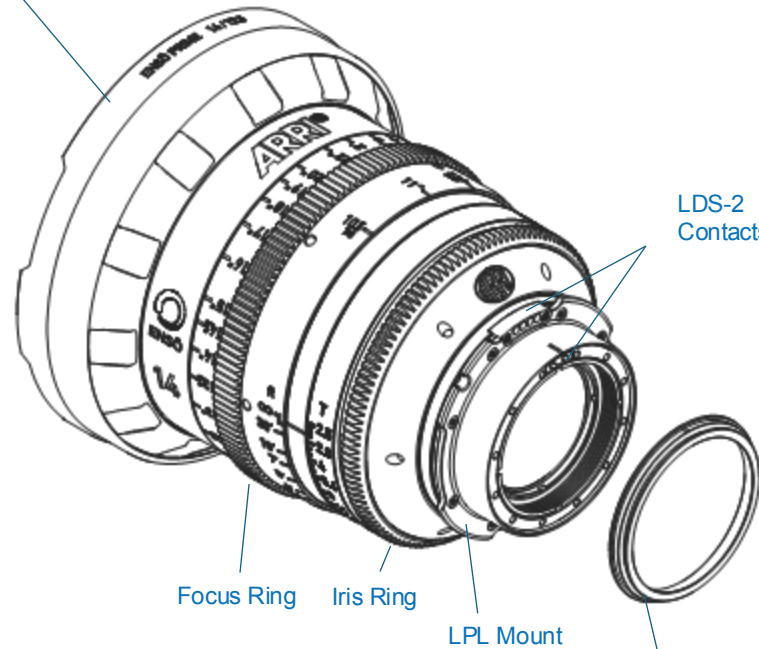

Ensō Prime Net Holder (EP/NH)
→ removeable

Left

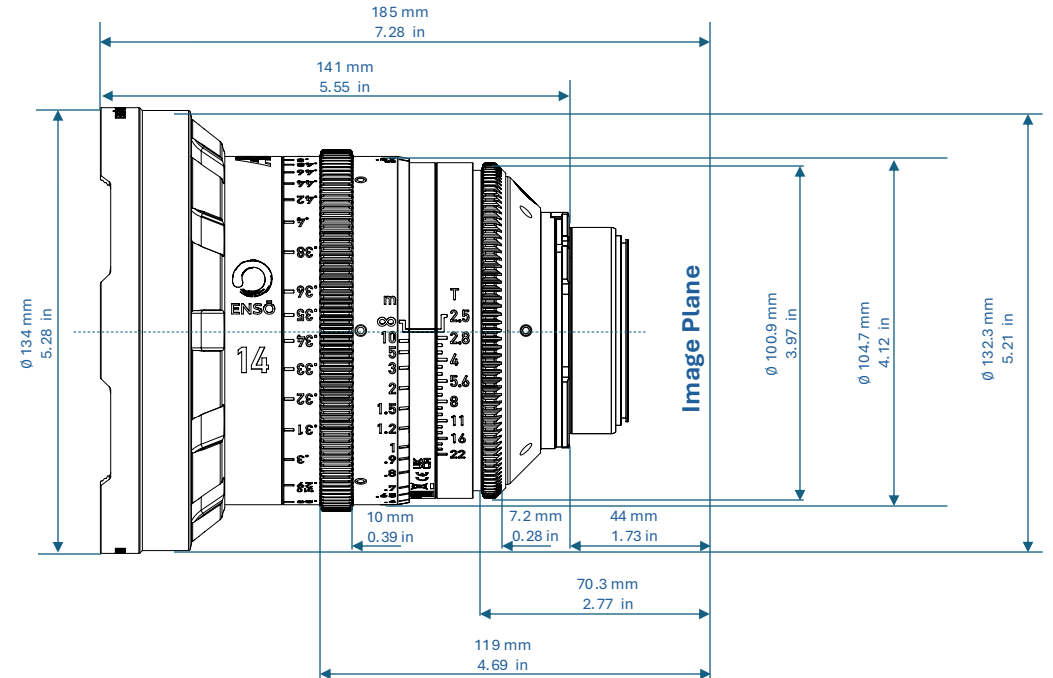

ARRI Ensō Prime – 10.5/T2.8 & 14/T2.5 (with Front Ring 134 mm)

Right

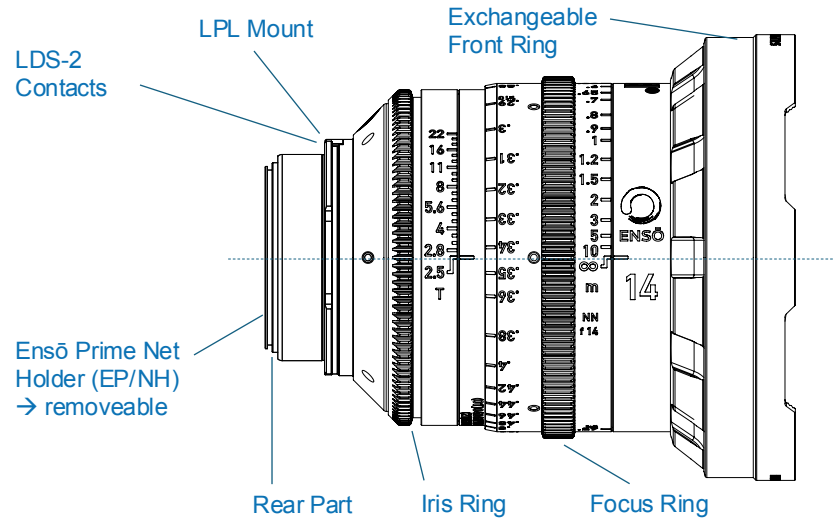

Rear

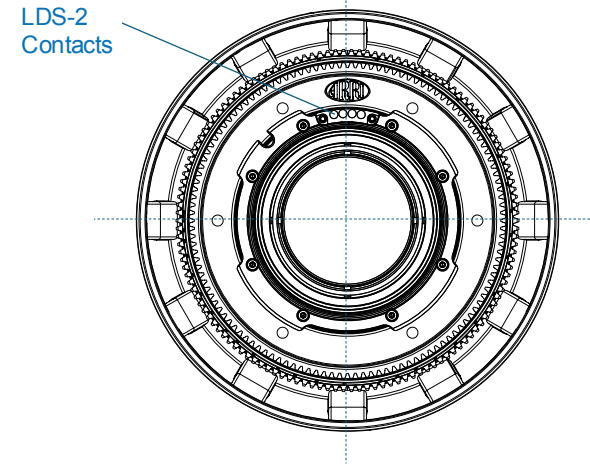

Top

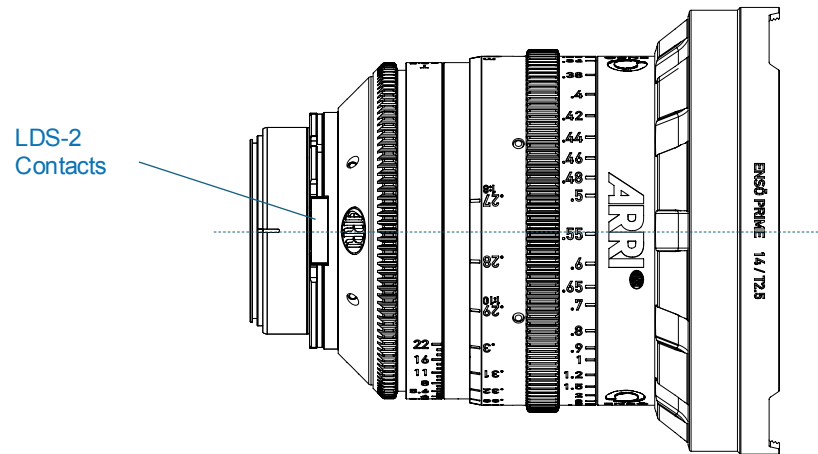

Bottom

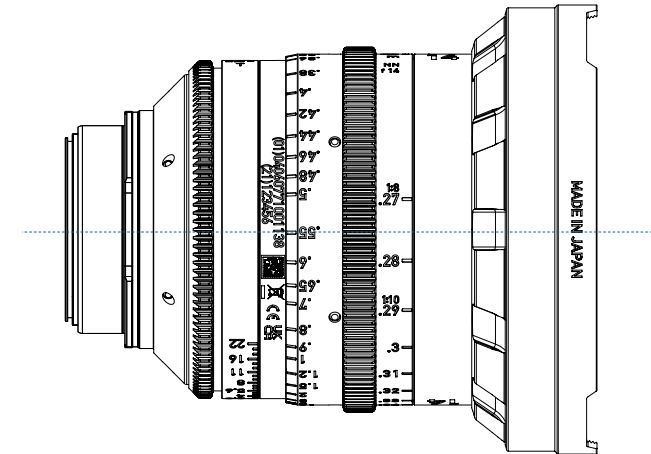

ARRI Ensō Prime – 10.5/T2.8 & 14/T2.5 (with Front Ring 156 mm)



PRIME LENS DIMENSIONS – Version 2024-11

Technical Data are subject to change without notice

Overview

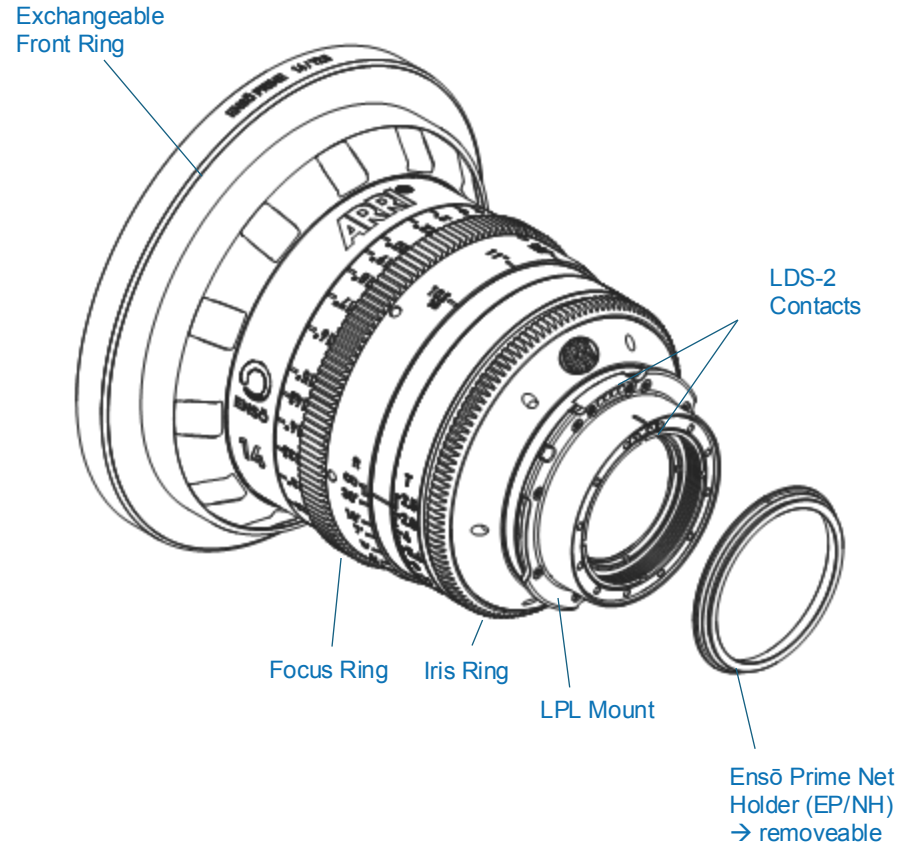

Left

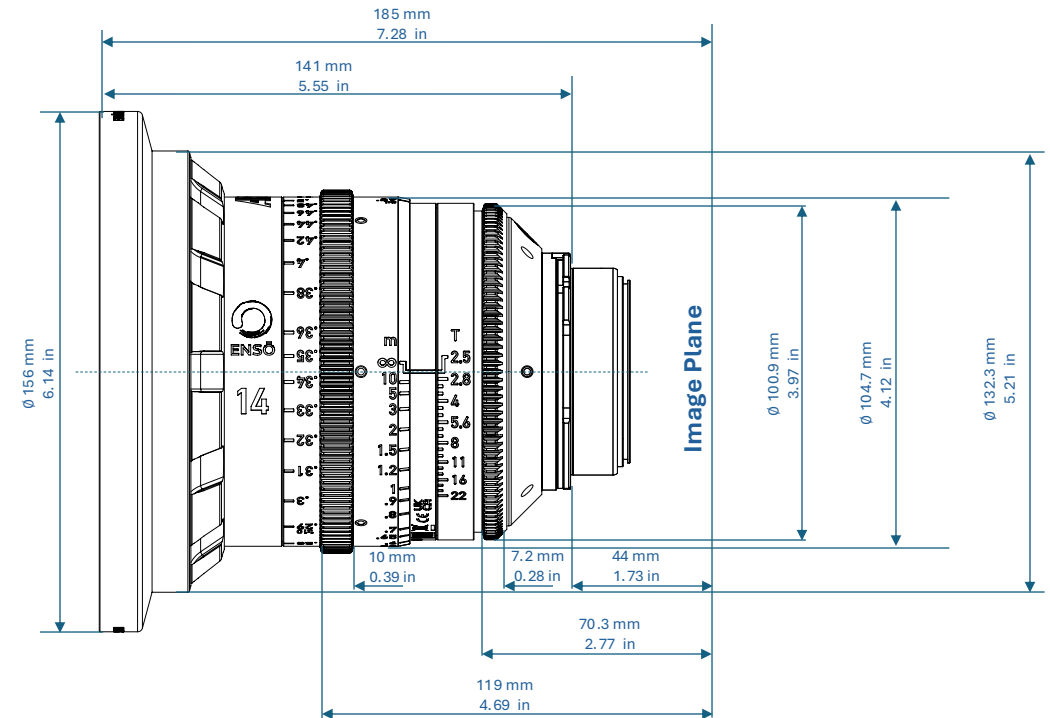

ARRI Ensō Prime – 10.5/T2.8 & 14/T2.5 (with Front Ring 156 mm)



PRIME LENS DIMENSIONS – Version 2024-11

Technical Data are subject to change without notice

Right

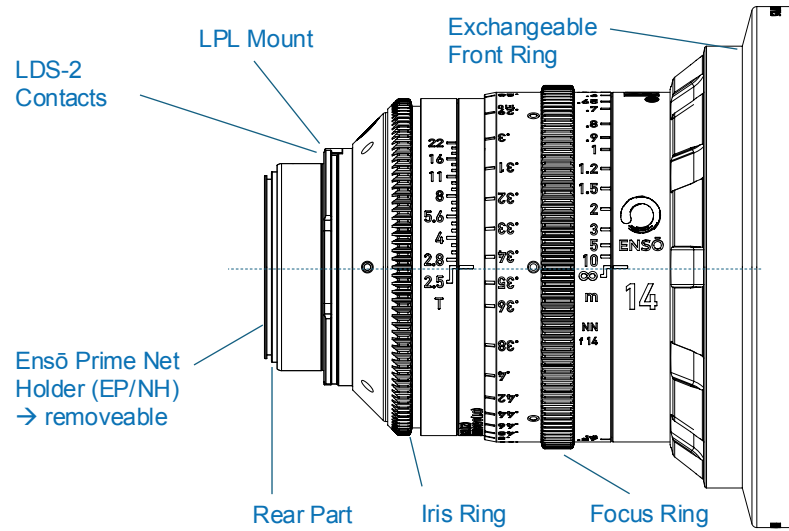

Rear

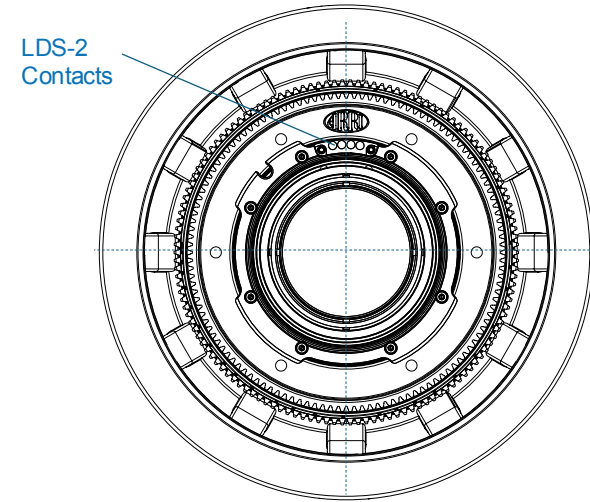

Top

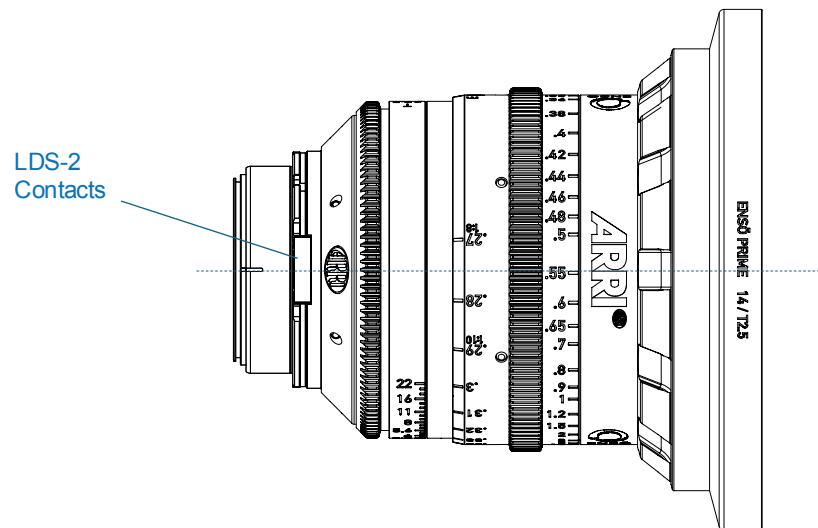

Bottom

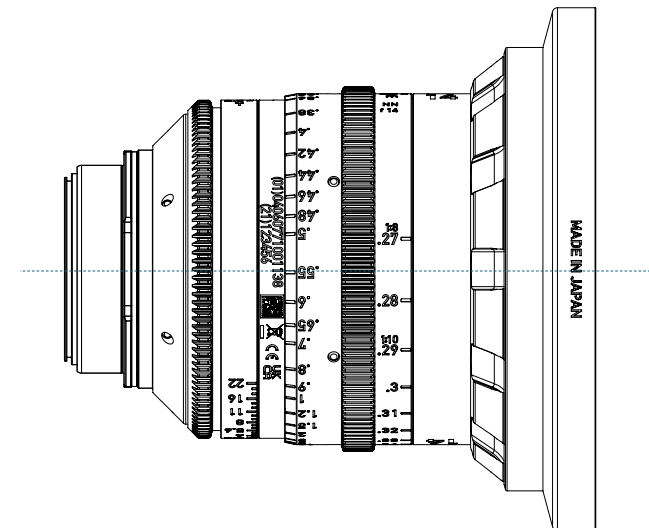

ARRI Ensō Prime – 18 ... 58/T2.1

Overview

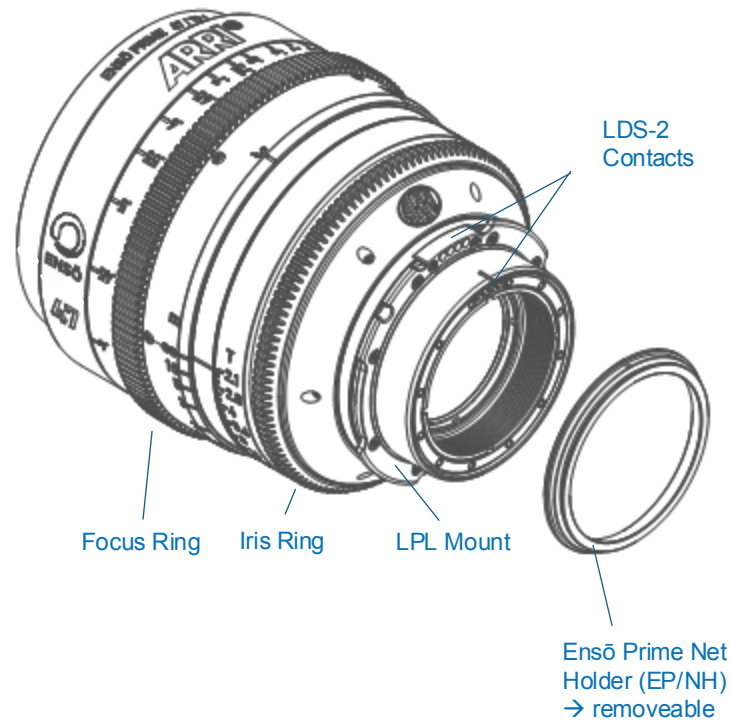

Left

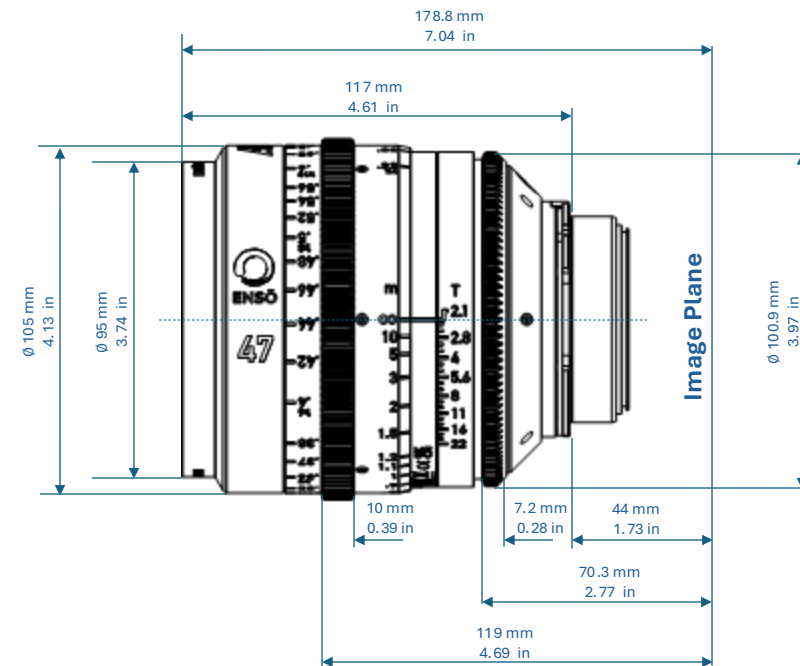

ARRI Ensō Prime – 75 ... 105/T2.1

Overview

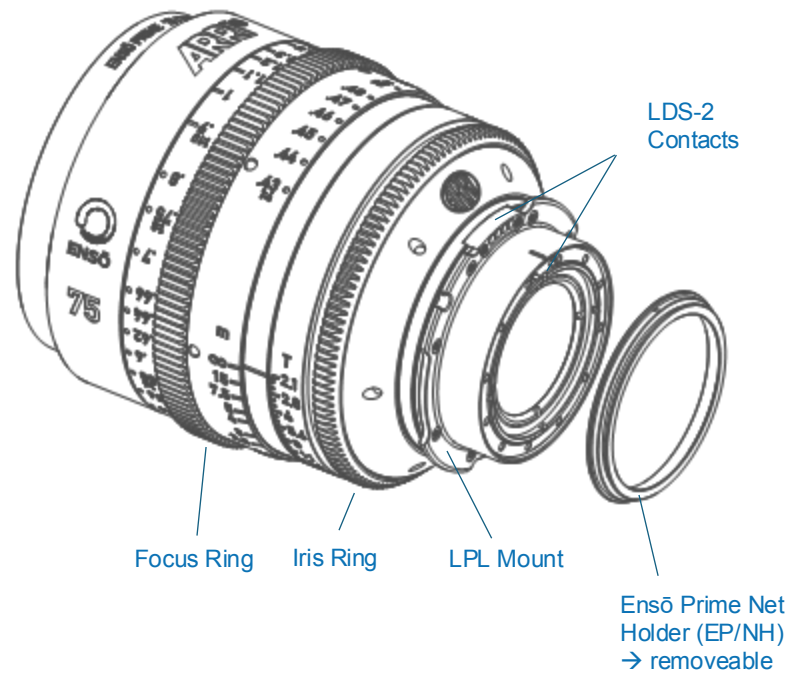

Left

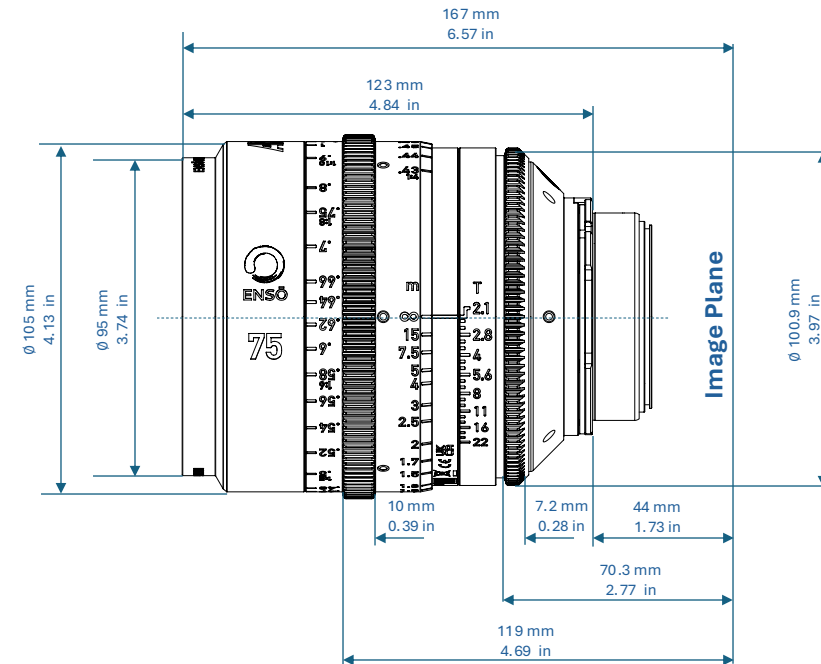

ARRI Ensō Prime – 75 ... 105/T2.1

Right

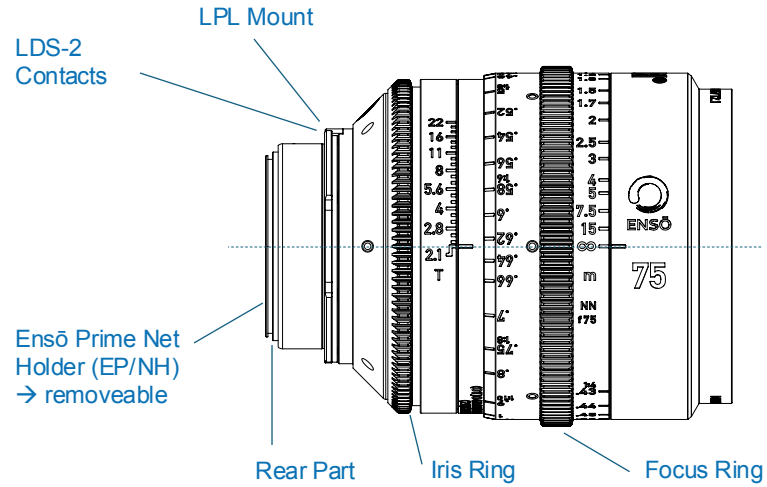

Rear

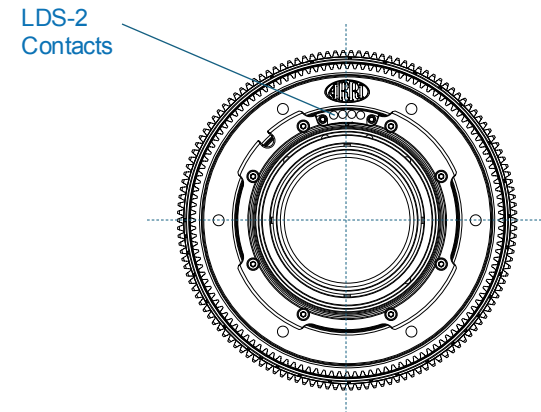

Top

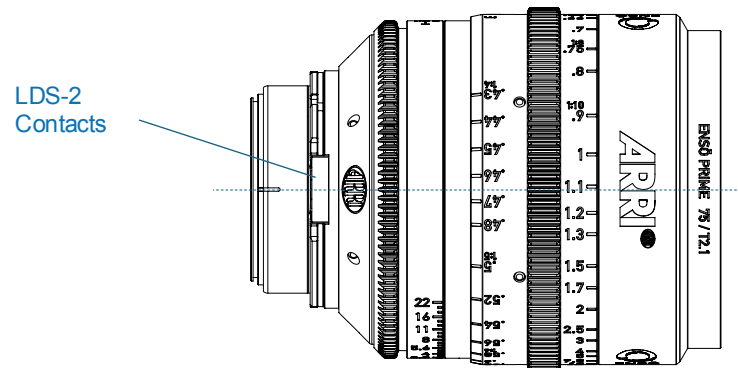

Bottom

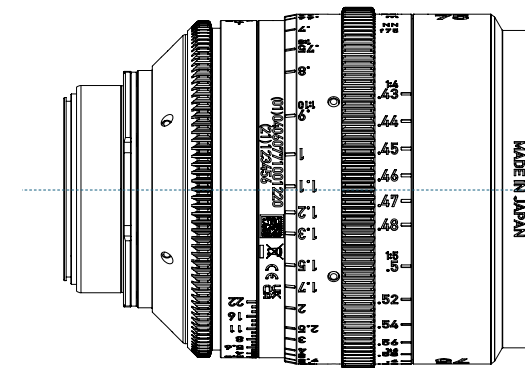

ARRI Ensō Prime – 150/T2.5



PRIME LENS DIMENSIONS – Version 2024-11

Technical Data are subject to change without notice

Overview

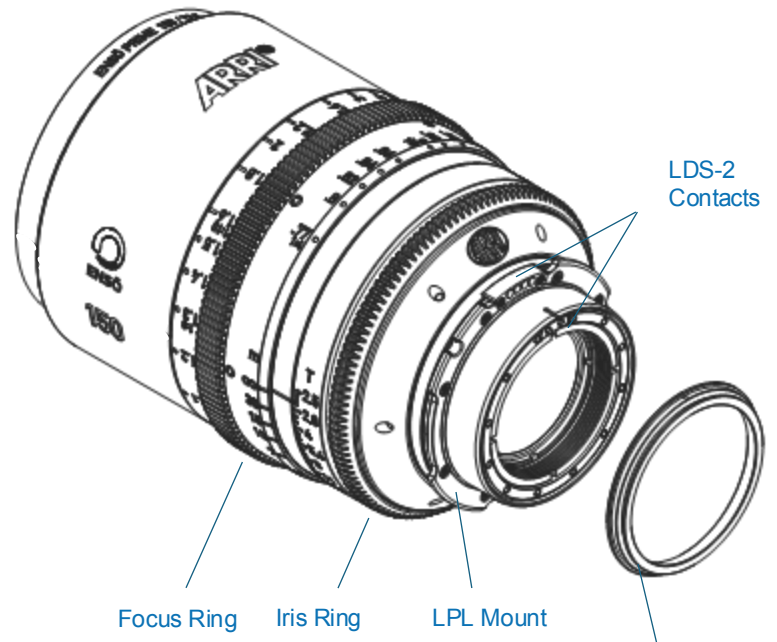

Ensō Prime Net Holder (EP/NH)
→ removeable

Left

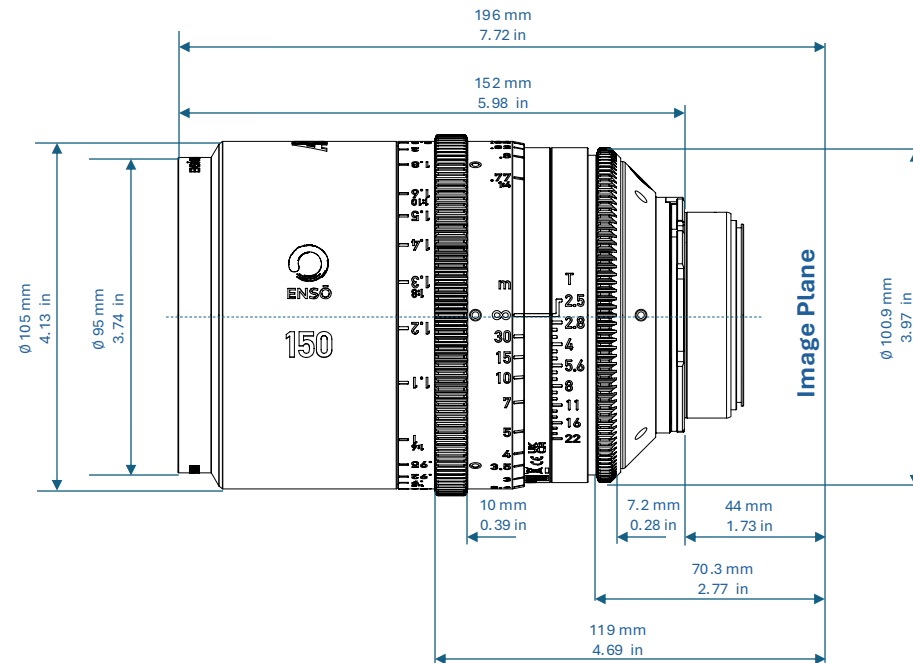

ARRI Ensō Prime – 150/T2.5



PRIME LENS DIMENSIONS – Version 2024-11

Technical Data are subject to change without notice

Right

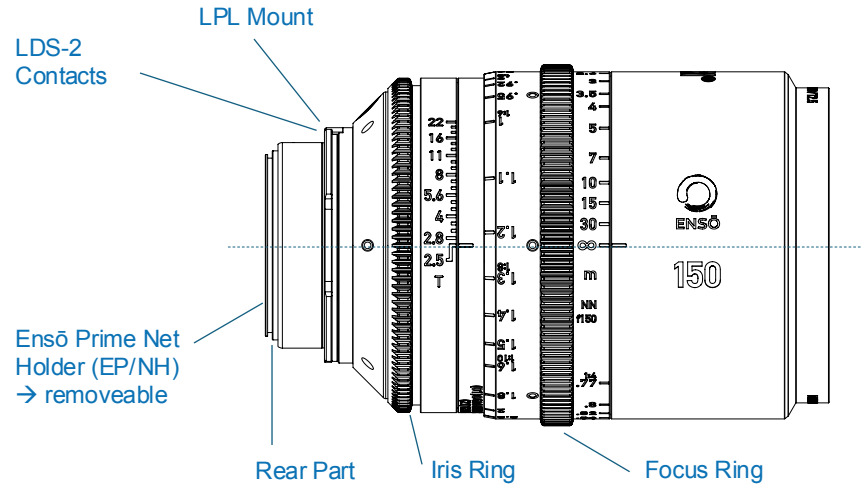

Rear

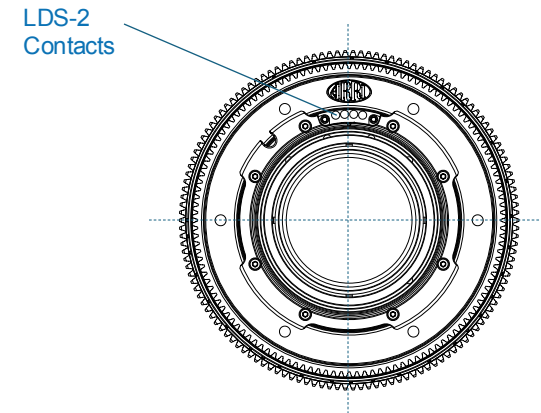

Top

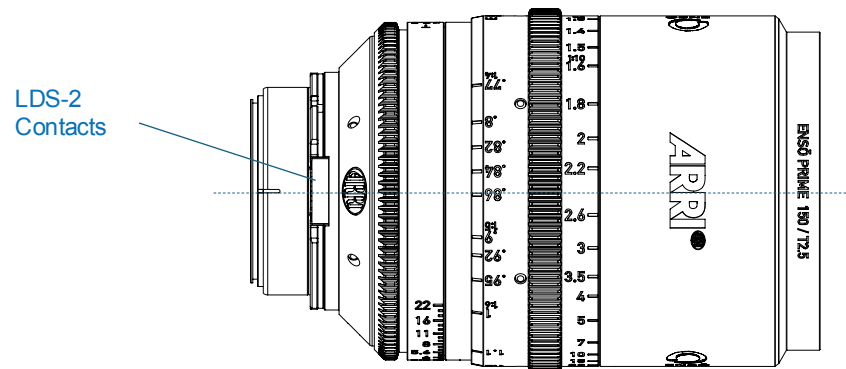

Bottom

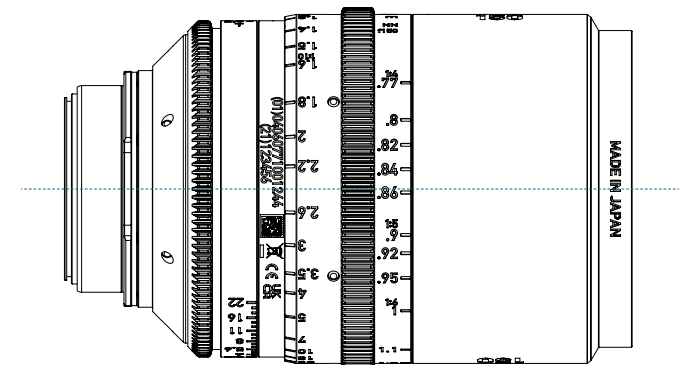

ARRI Ensō Prime – 250/T2.8



PRIME LENS DIMENSIONS – Version 2024-11

Technical Data are subject to change without notice

Overview

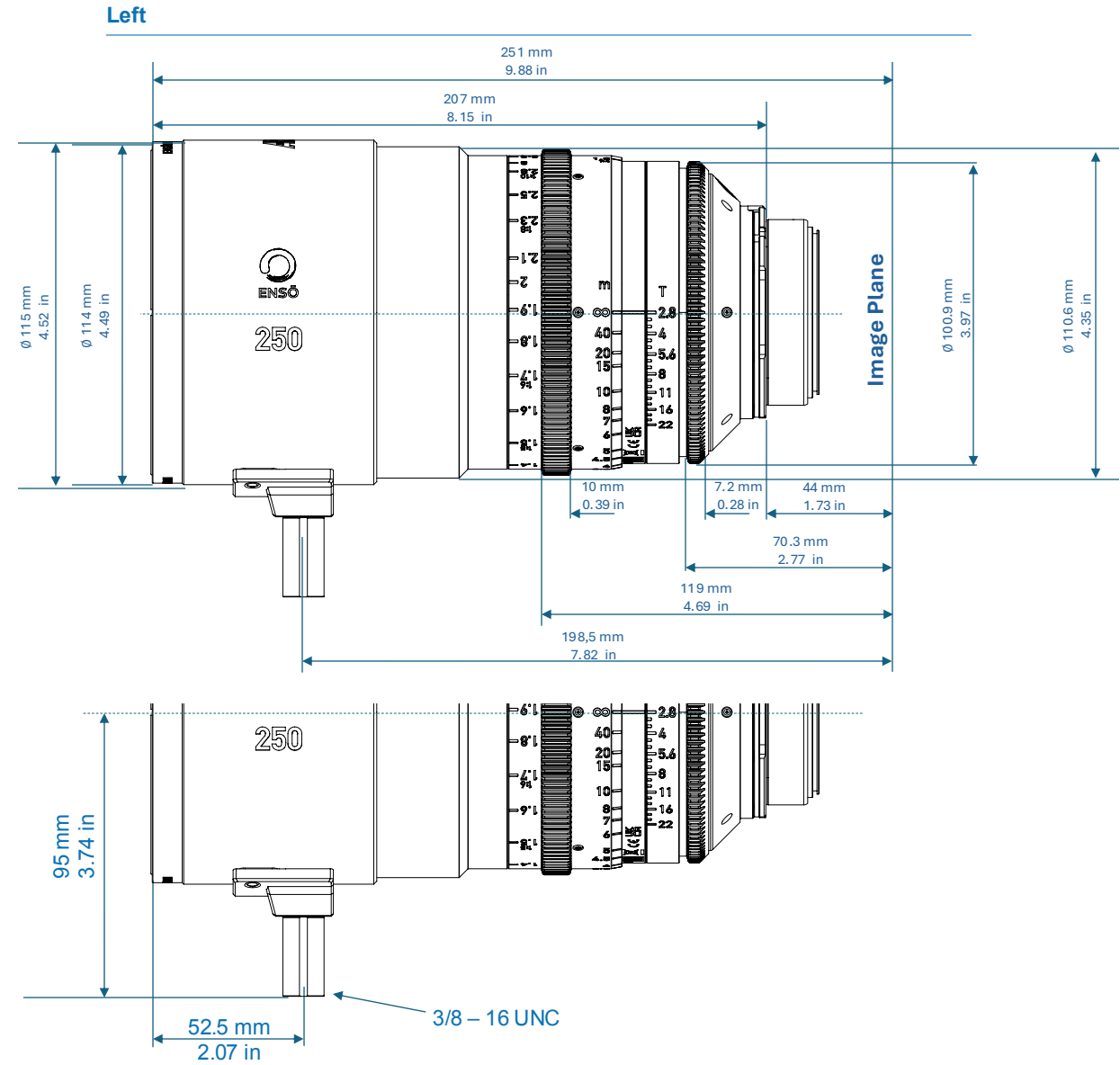
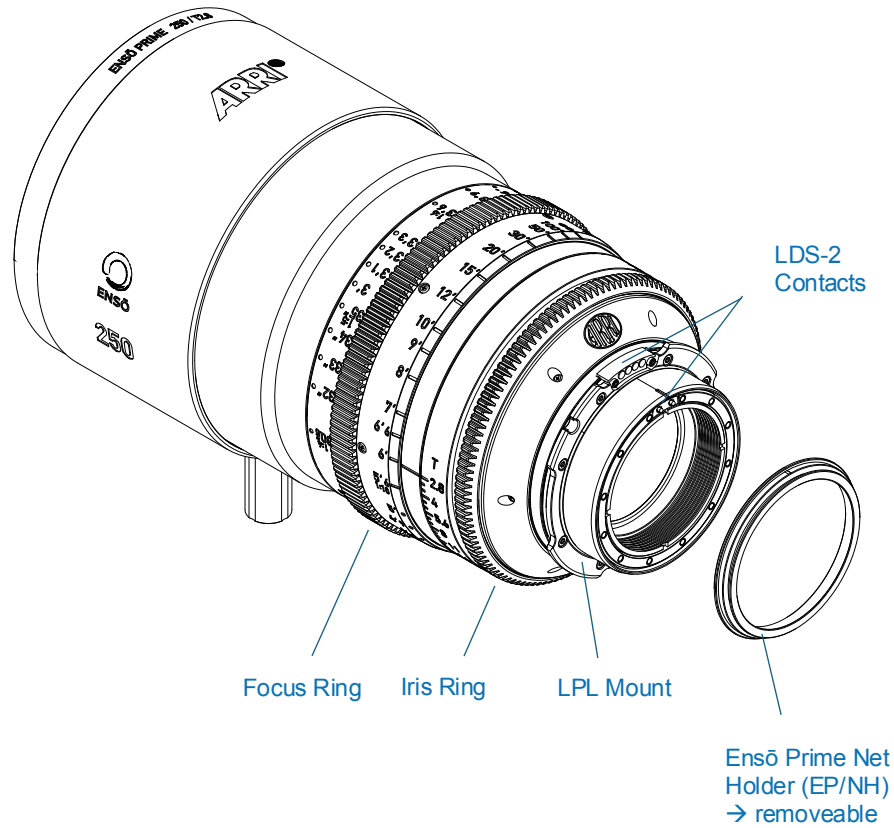

ARRI Ensō Prime – 250/T2.8

Right

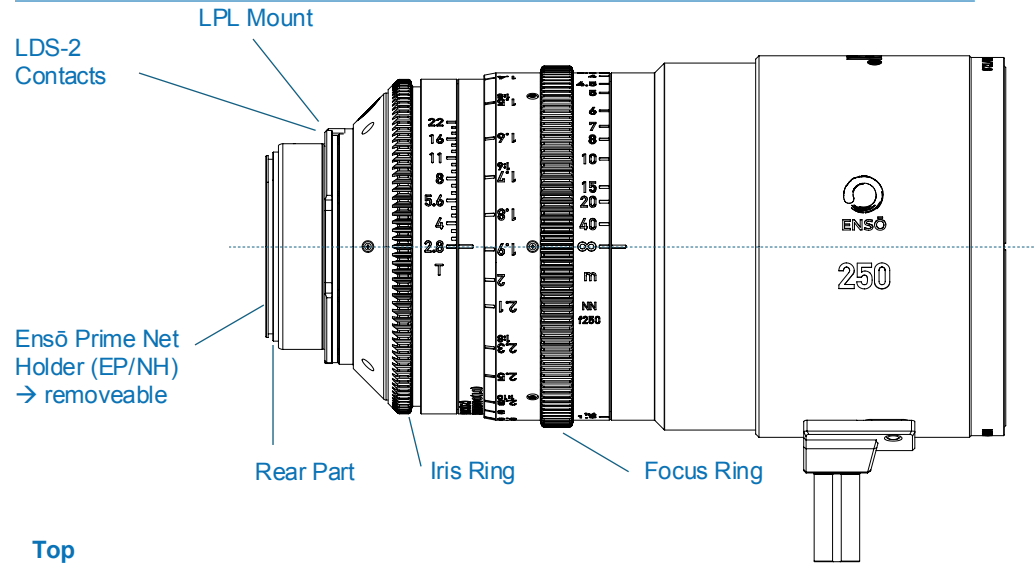

ARRI Ensō Extender 1.4x



PRIME LENS DIMENSIONS – Version 2024-11

Technical Data are subject to change without notice

Overview

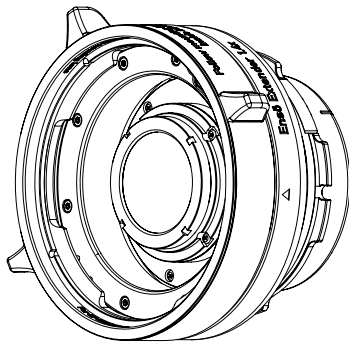
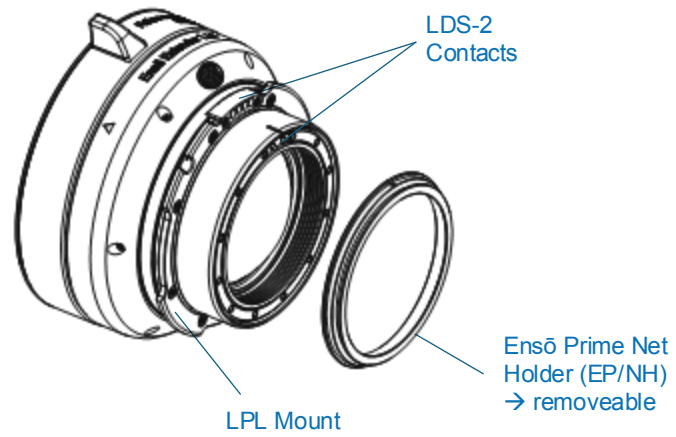

Left

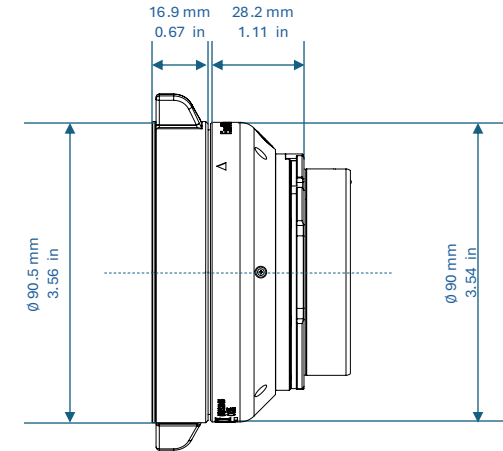

Right

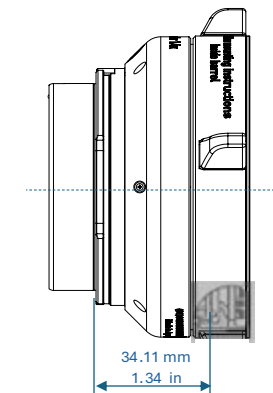

ARRI Ensō Extender 2.0x



PRIME LENS DIMENSIONS – Version 2024-11

Technical Data are subject to change without notice

Overview

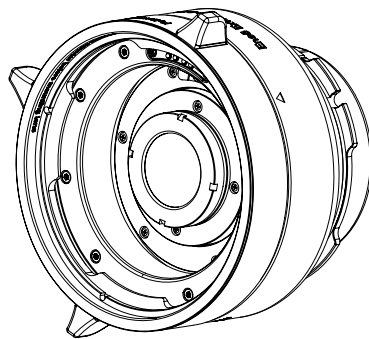
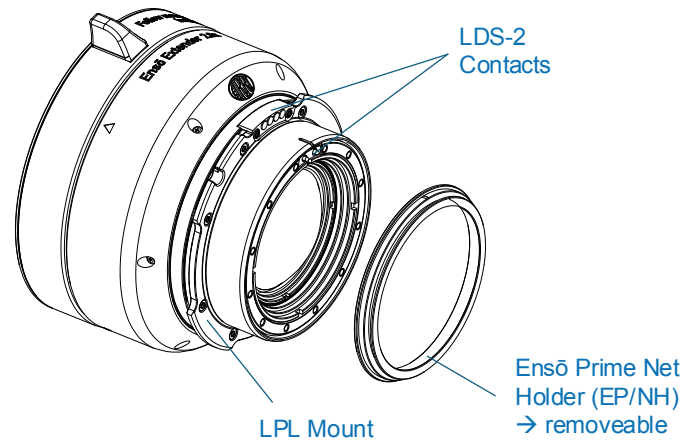

Left

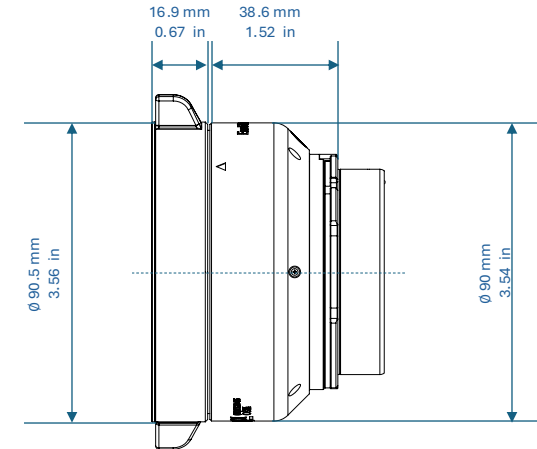

Right

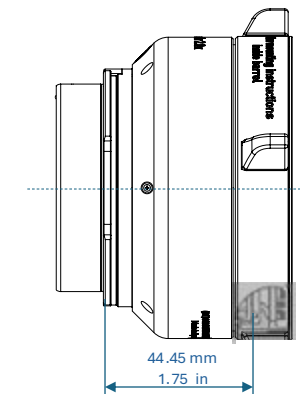

ARRI Ensō Vintage Elements & Ensō Creative Adapter

Overview

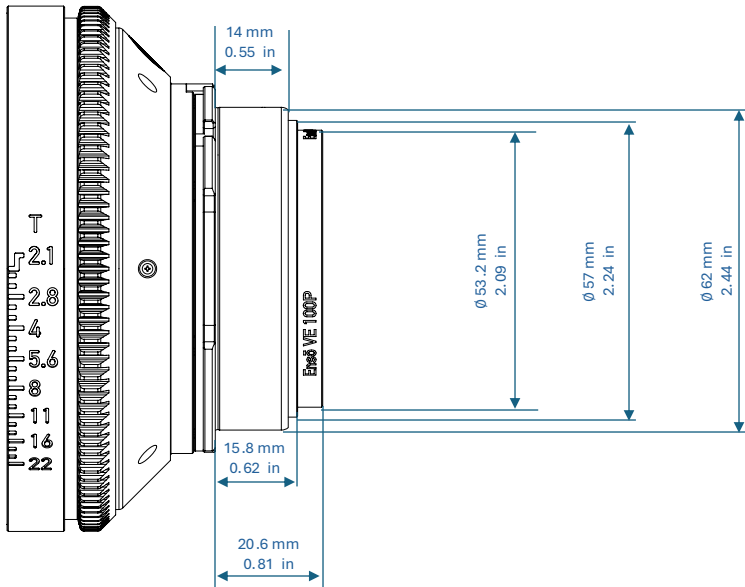

Dimensions apply to all Ensō Vintage Elements

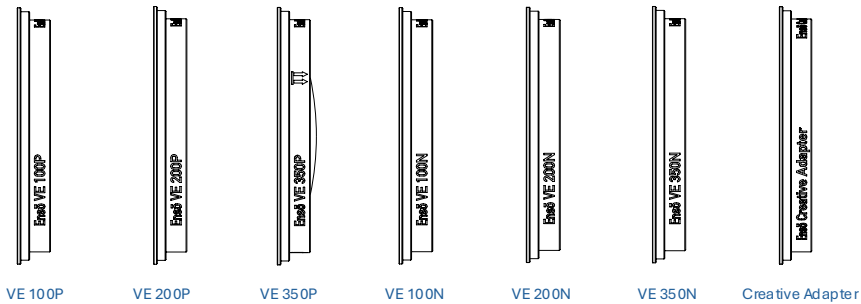

Left

The lens element of the Ensō VE 350P protrudes beyond the edge of the filter (see drawing)

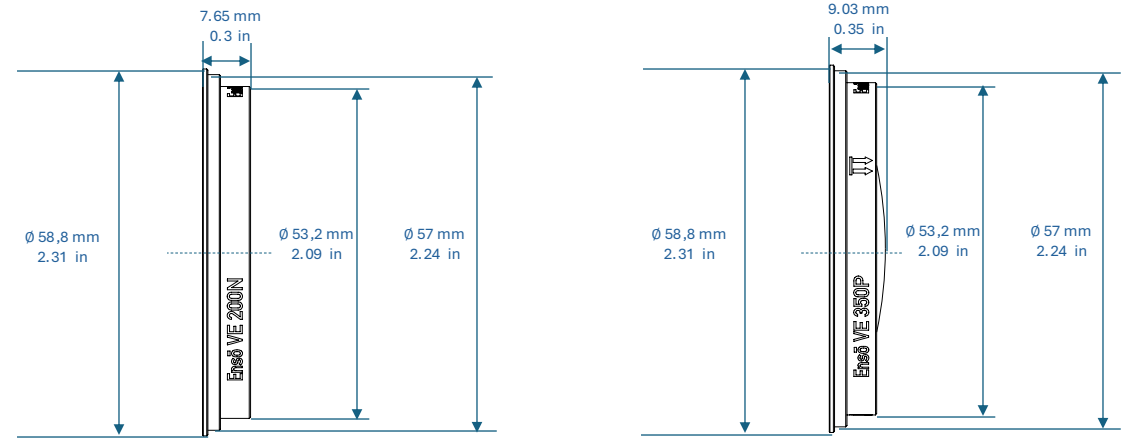

Front

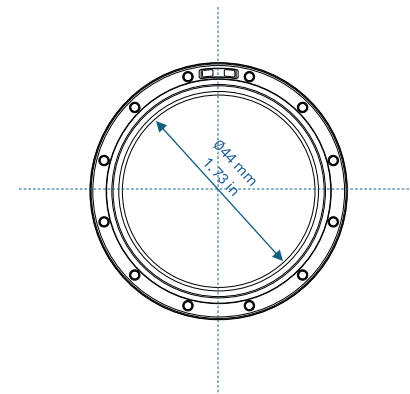

Back

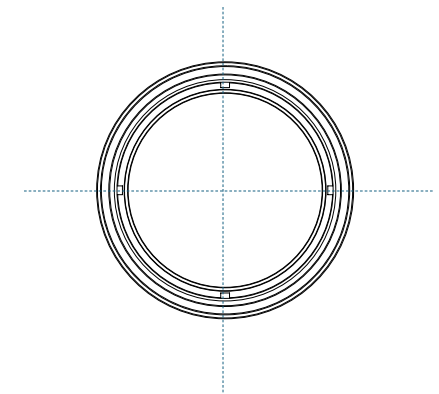

ARRI Ensō Creative Adapter, Retaining Rings & Retaining Ring Tool



PRIME LENS DIMENSIONS – Version 2024-11

Technical Data are subject to change without notice

Overview

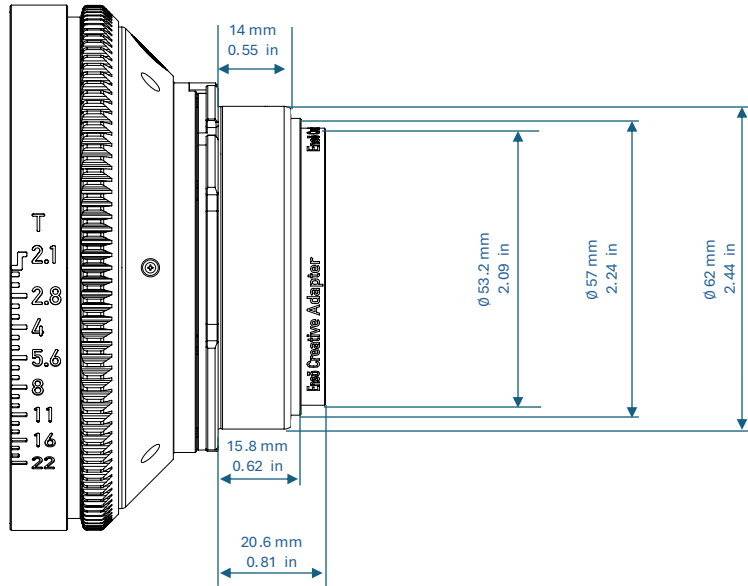

Creative Adapter (Left)

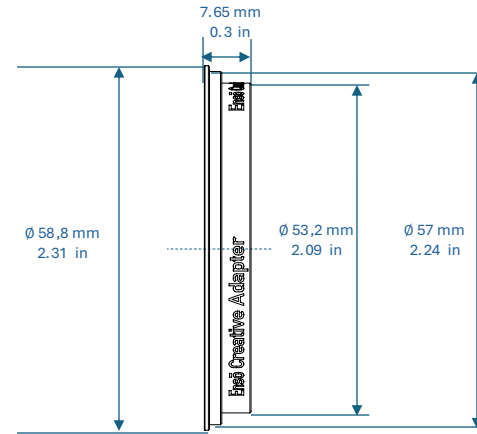

Retaining Ring Tool

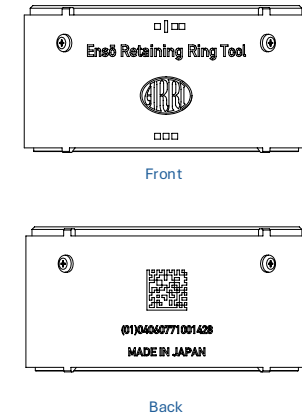

Retaining Rings

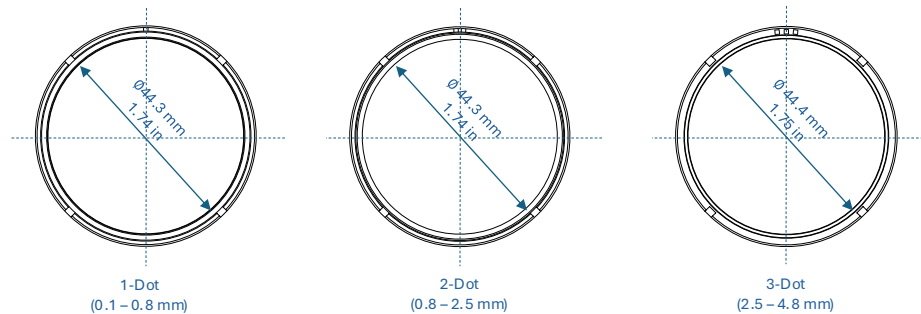

Creative Adapter (Front)

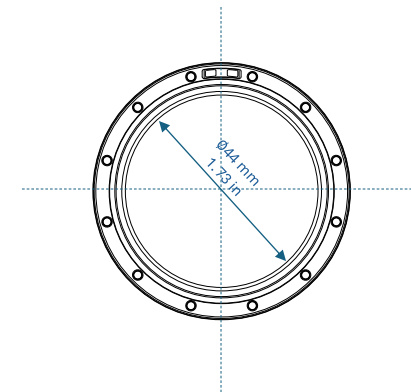

Creative Adapter (Back)

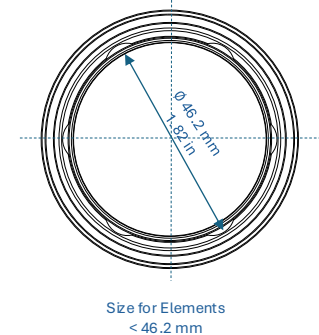

15 ARRI Service Contacts

Please see the current list of service partners at [service contacts](#).



Arnold & Richter Cine Technik GmbH & Co.
Betriebs KG
Herbert-Bayer-Str. 10
80807 Munich
Germany
+49 89 3809 2121
service@arri.de
Business hours:
Mo. - Fr. 09:00 - 17:00 (CET)

ARRI Inc. / East Coast
617 Route 303
NY 10913 Blauvelt
USA
+1 845 353 1400
service@arri.com
Business hours:
Mo. - Fr. 08:30 am - 05:30 pm (EST)

ARRI Inc. / West Coast
3700 Vanowen Street
CA 91505 Burbank
USA
+1 818 841 7070
service@arri.com
Business hours:
Mo. - Fr. 09:00 am- 05:00 pm (PT)

ARRI Asia Pte. Ltd.
164 Kallang Way, #03-01
349248 Singapore
Singapore
+65 6230 9488
service@arri.asia

ARRI Australia Pty Ltd
Suite 2, Building B, 12 Julius Ave
NSW 2113 North Ryde
Australia
+61 2 9855 4305
service@arri.com.au
Business hours:
Mo. - Fr. 08:00 am - 05:00 pm (AEST)

ARRI Brasil Ltda
Rua Clodomiro Amazonas, 1158 - Lojas 45 e 46,
Vila Nova Conceição
São Paulo, SP 04537-901
Brasil
+55 1150419450
arribrasil@arri.com
Business hours:
Mo. - Fr. 09:00 am - 05:30 pm (BRT)

ARRI Canada Limited
76 Six Point Road
Etobicoke, ON M8Z 2X2
Canada
+1 416 255 3335
service@arri.com
Business hours:
Mo. - Fr. 08:30 am - 05:00 pm (EDT)

ARRI China (Beijing) Co. Ltd.
Chaowai SOHO Tower C, 6/F, 0628/0656,
Chaowai
Dajie Yi 6
Beijing
China
+86 10 5900 9680
service@arri.cn
Business hours:
Mo. - Fr. 09:00 am - 06:00 pm (CST)

ARRI CT Limited / London
2 Highbridge, Oxford Road
UB8 1LX Uxbridge
United Kingdom
+44 1895 457 000
service@arri-ct.com
Business hours:
Mo. - Thu. 09:00 am - 5:30 pm (GMT)
Fr. 09:00 am - 5:00 pm (GMT)

ARRI Hong Kong Limited
26/F Gravity, 29 Hing Yip Street
Kwun Tong, Hong Kong
P. R. China
+852 2571 6288
servicehk@arri.asia
Business hours:
Mo. - Fr. 09:00 am - 06:00 pm (HKT)

ARRI Korea Limited
42, World Cup buk-ro 1-gil, Mapo-gu
04031 Seoul
Korea
+82 (0)70 4419 6401
service@arri.kr
Business hours:
Mo. - Fr. 9:00 - 18:00 (KST)

CINEOM Broadcast DMCC.
HDS Business Center, Unit No. 3503, Floor No.
35 Cluster M
Jumeirah Lake Towers
Dubai
Dubai, UAE
+971 (0) 45570477
arriservice.me@ceneom.com
Business hours:
Sa. - Th. 9:00 am- 06:00 pm

CINEOM Broadcast India Pvt. Ltd.
C-4, Goldline Business Centre, Link Rd. Malad
West
400 064 Mumbai
India
+91 (0)22 42 10 9000
arrisupportindia@ceneom.in
Business hours:
Mo. - Sa. 10:00 am - 06:00 pm (IST)

LİNKA GÖRÜNTÜ IŞIK VE SES SİSTEMLERİ
TİCARET ANONİM ŞİRKETİ
Distribütör & Service
Maslak Mah. AOS 55. Sokak 42 Maslak A Blok
SİTESİ
NO: 2 İÇ KAPI NO: 1
Sarıyer, İstanbul
Turkey
+90 2123584520
service@linkgroup.com.tr



ENSŌ