



ADPSM

Wireless Personal Monitor System

Shure Axient Digital PSM user guide. Operational presets, RF coordination, ShowLink networking, firmware updates and more for ADXR, ADTQ / ADTD, AD8C, and AD221.

Version: 0.2 (2025-A)

Table of Contents

ADPSM Wireless Personal Monitor System	4	Operational Presets	19
Safety and Regulatory Information for Wireless Products	4	Transmission Modes	19
Explanation of Symbols	4	Spatial Diversity	20
Important Safety Instructions	4	Internal Antenna Combining	20
Important Safety Information	5	Preset Diagrams	20
Products with AC Adapters	5	Combined System Diagrams	22
Safety Information for Batteries	5	ShowLink Remote Control	31
Important Safety Instructions for Listening and IEM Products	6	What is ShowLink?	31
What is Axient® Digital PSM®?	7	How ShowLink Works	32
Features	7	ShowLink Test	32
ADXR Bodypack Receiver Overview	8	Create a ShowLink Network	33
ADTQ Quad and ADTD Dual Transmitter Overview	9	ShowLink Network ID	33
AD8C Antenna Combiner Overview	11	Operation	33
System Set Up	13	ADTQ/ADTD Wireless Transmitter	33
Mounting Instructions	13	ADXR Portable Wireless Receiver	44
Multiple System Setup	13	AD8C Antenna Combiner	51
Firmware Updates	14	Networking	55
Radio Frequency (RF) Settings	14	Guided Network Configuration	55
Groups & Channels	14	Accessing the Network with a Computer	56
Sync	16	Static IP Addressing	57
Setting the Frequency Manually	17	Network Browser	57
Requesting a New Frequency from a Spectrum Manager 17	17	Connecting Transmitters	57
Assigning Receivers to Receiver Slots	17	Specifications	58
Channel Quality Meter	18	ADXR Wireless Bodypack Receiver	59
RF System Gain	18	ADTQ (Quad) and ADTD (Dual) Transmitters	63
RF Mute	18	AD8C Antenna Combiner	67
Squelch	18	AD221 Antenna Combiner	69
		SBC441 4-Bay Networked Charger	70
		Important Product Regulatory Information	70
		Introduction to EMC	71



Regulatory Information for Class B EMC Products	71	Environmental Regulatory Information	76
Regulatory Information for Wireless Products Utilizing TV Frequency Bands	75	Battery Regulatory Information	77
Regulatory Information for Wireless ZIGBEE Devices	75	Certifications	78

ADPSM

Wireless Personal Monitor System

Safety and Regulatory Information for Wireless Products

Explanation of Symbols

	This symbol indicates that dangerous voltage constituting a risk of electric shock is present within this unit.
	This symbol indicates that there are important operating and maintenance instructions in the literature accompanying this unit.

Important Safety Instructions

1. READ these instructions.
2. KEEP these instructions.
3. HEED all warnings.
4. FOLLOW all instructions.
5. DO NOT use this apparatus near water.
6. CLEAN ONLY with dry cloth.
7. DO NOT block any ventilation openings. Allow sufficient distances for adequate ventilation and install in accordance with the manufacturer's instructions.
8. DO NOT install near any heat sources such as open flames, radiators, heat registers, stoves, or other apparatus (including amplifiers) that produce heat. Do not place any open flame sources on the product.
9. DO NOT defeat the safety purpose of the polarized or grounding type plug. A polarized plug has two blades with one wider than the other. A grounding type plug has two blades and a third grounding prong. The wider blade or the third prong are provided for your safety. If the provided plug does not fit into your outlet, consult an electrician for replacement of the obsolete outlet.
10. PROTECT the power cord from being walked on or pinched, particularly at plugs, convenience receptacles, and the point where they exit from the apparatus.
11. ONLY USE attachments/accessories specified by the manufacturer.
12. USE only with a cart, stand, tripod, bracket, or table specified by the manufacturer, or sold with the apparatus. When a cart is used, use caution when moving the cart/apparatus combination to avoid injury from tip-over.



13. UNPLUG this apparatus during lightning storms or when unused for long periods of time.
14. REFER all servicing to qualified service personnel. Servicing is required when the apparatus has been damaged in any way, such as power supply cord or plug is damaged, liquid has been spilled or objects have fallen into the apparatus, the apparatus has been exposed to rain or moisture, does not operate normally, or has been dropped.
15. DO NOT expose the apparatus to dripping and splashing. DO NOT put objects filled with liquids, such as vases, on the apparatus.
16. The MAINS plug or an appliance coupler shall remain readily operable.

17. The airborne noise of the Apparatus does not exceed 70dB (A).
18. Apparatus with CLASS I construction shall be connected to a MAINS socket outlet with a protective earthing connection.
19. To reduce the risk of fire or electric shock, do not expose this apparatus to rain or moisture.
20. Do not attempt to modify this product. Doing so could result in personal injury and/or product failure.
21. Operate this product within its specified operating temperature range.
22. Follow local regulations and consult qualified personnel if the product installation or relocation requires construction work. Choose mounting hardware and an installation location that can support the weight of the product. Avoid locations subject to constant vibration. Use the required tools to install the product properly. Inspect the product periodically.

WARNING:

- Voltages in this equipment are hazardous to life. No user-serviceable parts inside. Refer all servicing to qualified service personnel. The safety certifications do not apply when the operating voltage is changed from the factory setting.
- If water or other foreign objects enter the inside of the device, fire or electric shock may result.

Important Safety Information

Products with AC Adapters

1. Use only AC adapter that is provided with your product.
2. If this product is powered by an AC adapter other than the AC adapter that comes with your product, it could result in personal injury and/or product failure.

Safety Information for Batteries

1. Battery packs may explode or release toxic materials. Risk of fire or burns. Do not open, crush, modify, disassemble, heat above 140°F (60°C), or incinerate.
2. Follow instructions from manufacturer
3. Only use Shure charger to recharge Shure rechargeable batteries

WARNING:

Danger of explosion if battery incorrectly replaced. Replace only with same or equivalent type.

Do not dispose of the battery along with household waste. Check with local vendor for proper disposal of used battery packs.

4. Never put batteries in mouth. If swallowed, contact your physician or local poison control center
5. In the event of a cell leaking, do not allow the liquid to come in contact with the skin or eyes. If contact has been made, wash the affected area with copious amounts of water and seek medical advice.
6. Do not short circuit; may cause burns or catch fire
7. Do not charge or use battery packs other than Shure rechargeable batteries
8. Batteries (battery pack or batteries installed) shall not be exposed to excessive heat such as sunshine, fire or the like
9. Do not immerse the battery in liquid such as water, beverages, or other fluids.
10. Do not attach or insert battery with polarity reversed.
11. Keep away from small children.
12. Do not use abnormal batteries.
13. Pack the battery securely for transport.

Note: Use only with the included power supply, batteries, or a Shure-approved equivalent.

Storing Batteries

If batteries are to be stored for more than eight days, they should be placed into a temperature controlled storage area. Recommended battery storage temperature is 10 to 25°C (50 to 77°F).

Additional battery storage information is available at shure.com/battery-storage.



Important Safety Instructions for Listening and IEM Products

1. If water or other foreign objects enter the inside of the device, fire or electric shock may result.
2. Do not attempt to modify this product. Doing so could result in personal injury and/or product failure.
3. Do not use when a failure to hear your surroundings could be dangerous, such as while driving, or when biking, walking, or jogging where traffic is present and accidents could occur.
4. Keep this product and its accessories out of reach of children. Handling or use by children may pose a risk of death or serious injury. Contains small parts and cords that may pose risk of choking or strangulation.
5. Prior to inserting the earphone, always recheck the sleeve to make sure it is firmly attached to the nozzle to decrease the risk of sleeves detaching from the nozzle and becoming lodged in your ear. If a sleeve becomes lodged in your ear, seek professional medical assistance to remove the sleeve.
6. Stop using the earphones/headphones and consult a medical professional if you experience irritation, excessive wax buildup, or other discomfort.

CAUTION

- Never disassemble or modify the device, as failures may result.
- Do not subject to extreme force and do not pull on the cable or failures may result.
- Keep the earphone dry and avoid exposure to extreme temperatures and humidity.
- If you are currently receiving ear treatment, consult your physician before using this device.

WARNING:

Use, clean, and maintain earphones according to manufacturer's instructions



High sound pressure

Hearing damage risk

To prevent possible hearing damage, do not listen at high volume levels for long periods.

WARNING FOR IN-EAR-MONITORS (IEM product_ONLY)

This device is able to produce sound volume higher than 85 dB SPL. Please check your maximum allowed continuous noise exposure level based on your national employment protection requirements.

WARNING:

LISTENING TO AUDIO AT EXCESSIVE VOLUMES CAN CAUSE PERMANENT HEARING DAMAGE. USE AS LOW A VOLUME AS POSSIBLE. Over exposure to excessive sound levels can damage your ears resulting in permanent noise-induced hearing loss (NIHL). Please use the following guidelines established by the Occupational Safety Health Administration (OSHA) on maximum time exposure to sound pressure levels before hearing damage occurs.

90 dB SPL at 8 hours	95 dB SPL at 4 hours	100 dB SPL at 2 hours	105 dB SPL at 1 hour
110 dB SPL at ½ hour	115 dB SPL at 15 minutes	120 dB SPL Avoid or damage may occur	

What is Axient[®] Digital PSM[®]?

Axient Digital PSM portable wireless monitor systems provide pristine RF signal and audio quality, ideally suited for the demands of professional touring and live sound applications. Pair your ADXR portable wireless receiver with an ADTQ or ADTD quad or dual transmitter; connect your devices to your ShowLink[™] network via an AD610 access point; expand your system using AD8C or AD221 antenna combiners.

Features

RF

- Selectable transmission modes that include multi-channel wideband, narrowband, and Analog FM mode
 - **Multi-Channel Wideband** - Achieve greater spectral efficiency with Shure WMAS innovation¹
 - **Narrowband** - Access more RF output power for even better range performance with traditional narrowband wireless technology
 - **Analog FM** - Achieve ultra-low latency performance with updated hybrid technology that combines high quality digital audio with traditional analog RF
- Optional spatial diversity available for enhanced coverage
- Optional internal antenna combining at reduced RF output power
- Wide tuning bandwidth²

¹ Software enabled availability of WMAS is region dependent

² Tuning bandwidth specifications are region dependent

Audio

- Analog and digital audio inputs (Analog, AES3, Dante[™], AES67)
- Front panel connection for headphones with adjustable volume

I/O

- Eight XLR and 1/4" combo connectors (switchable analog/AES)
- Two Dante-enabled Ethernet ports, two network control Ethernet ports with PoE
 - Split-Redundant mode: two ports of Ethernet, two ports of Dante
 - Switched mode: four ports of Ethernet, Four ports of Dante

Note: The transmitter can only power 1 PoE device at a time.

- Locking AC power connection
- AC power cascade to additional components
- Optional DC module available to support redundant power

ADXR Bodypack Receiver Overview

① RF Antenna

For RF signal.

② OLED Display

View menu screens and settings. Press any control button to activate the backlight.

③ Control Buttons

Use to navigate through parameter menus and to change settings.

④ Battery Compartment

Requires Shure SB910 rechargeable battery, or SB913A battery sled.

⑤ Battery Door

Latching door to secure battery.

⑥ Infrared (IR) Port

Align with the transmitter IR port during an IR Sync.

⑦ Battery Charging Contacts

Charging contacts for use with docking battery chargers.

⑧ SMA Connector

Connection point for RF antenna.

⑨ Power / Volume Control

When the receiver is off, turn the knob clockwise until it clicks to power on. Use knob to adjust the headphone volume. Turn and click counterclockwise to power off.

⑩ RF LED

Blue LED indicates RF connection.

11 Battery LED

- Off = unit is powered off
- Green = unit is powered on with sufficient battery
- Red = unit is powered on, battery is low, or battery error (see Troubleshooting)

12 Headphone Jack

1/8" jack with locking thread and headphone detection.

13 Belt Clip

Removable belt clip, reversible for inverted orientation.

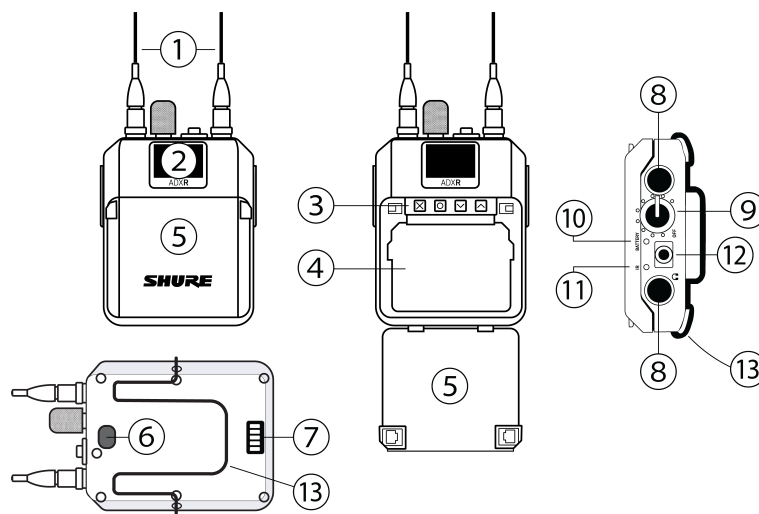

ADTQ Quad and ADTD Dual Transmitter Overview

Transmitter Front Panel

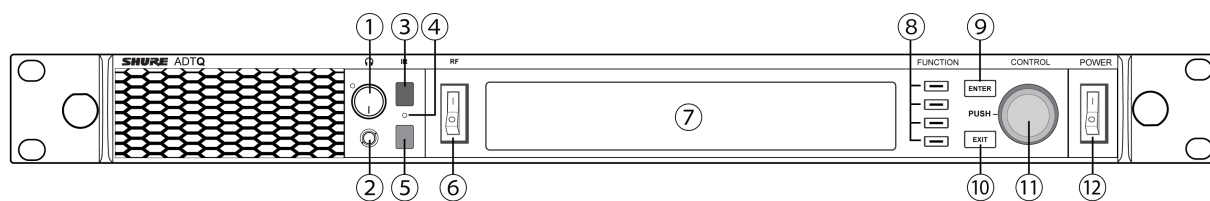

1 Headphone Volume Knob

Controls headphone volume for the selected channel. Clip indicator warns of signal overload or limiter engagement.

2 Monitor Jack

1/8" (3.5 mm) output jack.

3 Infrared (IR) Sync Window

Align with IR window on transmitter to sync.

④ Infrared (IR) Sync LED

The LED will turn red when the transmitter and receiver are correctly aligned for IR sync.

⑤ Ambient Light Sensor

Automatically detects external lighting conditions.

⑥ RF Switch

Toggles RF mute to prevent transmission of audio by suppressing the RF signal.

⑦ Display

Displays information for the selected channel.

⑧ Function Buttons

Press to access editing and configuration options. The buttons are named F1, F2, F3, F4 (from top to bottom) and illuminate to when editing options are available.

⑨ ENTER Button

Press to save changes.

⑩ EXIT Button

Press to cancel changes and return to main menus.

⑪ Control Wheel

- Push to enter a menu
- Push to select a channel or menu item
- Turn to scroll through menu items or to edit a parameter value

⑫ Power Switch

Powers the unit on or off.

Transmitter Back Panel

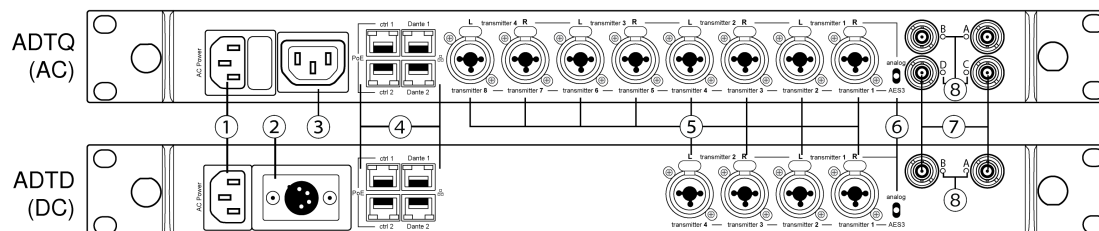

① AC Power Input

IEC locking connector, 100 - 240 V AC.

② DC Power Input

DC module version available to support redundant power supplies.

③ AC Power Cascade

AC module version uses IEC extension cables to loop power through multiple devices.

④ Ethernet Ports

Four Ethernet ports carry the following signals:

- ctrl 1: Network control
- ctrl 2: Network control
- Dante Primary: Dante digital audio
- Dante Secondary: Dante digital audio

Network Status LEDs:

- Off: no network link
- On green: network link active
- Flashing green: network link active, rate corresponds to traffic volume
- Flashing amber: indicates the connection is 1 Gbps, rate corresponds to traffic volume

⑤ Audio Inputs

Connect to balanced or unbalanced outputs. Use either jack for mono input. Accepts male XLR or 6.35 mm (¼") TRS plugs.

⑥ Rear Input Switch

Analog or AES3 digital transmission.

⑦ Coaxial inputs

RF connection for antennas.

⑧ Status LED

Green LED indicates the antenna is configured for transmitting.

AD8C Antenna Combiner Overview

Front Panels

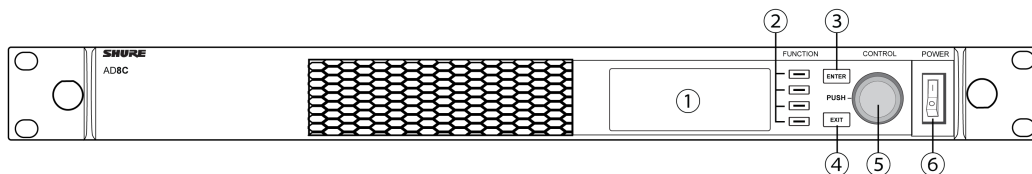

① Display

View and configure device settings.

② Function Buttons

Press to access editing and configuration options. The buttons are named F1, F2, F3, F4 (from top to bottom) and illuminate to when editing options are available.

③ ENTER Button

Press to save changes.

④ EXIT Button

Press to cancel changes and return to main menus.

⑤ Control Wheel

- Push to enter a menu
- Push to select a menu item
- Turn to scroll through menu items or to edit a parameter value

⑥ Power Switch

Powers the unit on or off.

Rear Panels

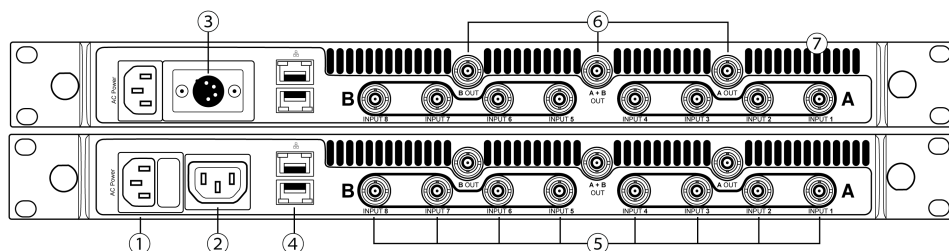

① AC Power Input

IEC locking connector, 100 - 240 V AC.

② AC Power Cascade

AC module version uses IEC extension cables to loop power through multiple devices.

③ DC Power Input

DC module version available to support redundant power supplies.

④ Ethernet Ports

Two RJ45 ports carry network control signals.

Network Status LEDs:

- Off: no network link
- On green: network link active
- Flashing green: network link active, rate corresponds to traffic volume
- Flashing amber: indicates the connection is 1 Gbps, rate corresponds to traffic volume

⑤ RF Inputs

Connect up to 8 transmitter outputs.

⑥ Antenna Outputs

Connect any Shure passive antenna that matches the RF operating range of the transmitter.

⑦ Exhaust Air Vents

For system cooling.

System Set Up

Mounting Instructions

This component is designed to fit into an audio rack.

Warning: To prevent injury this apparatus must be securely attached to the rack.

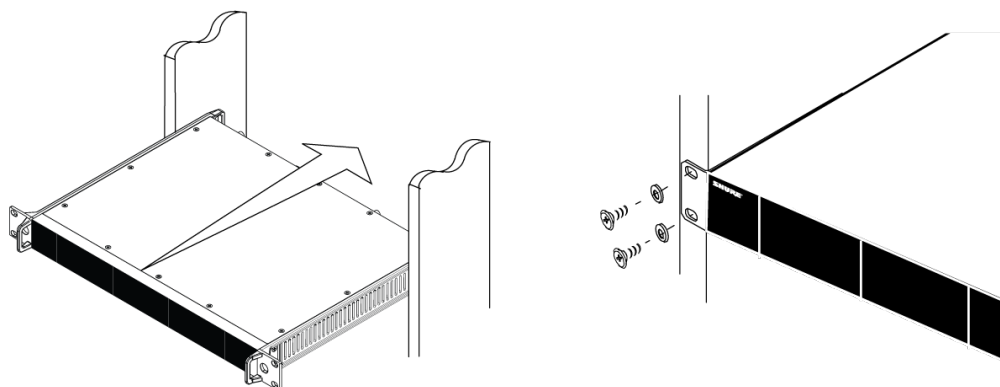

Rack Mount Instructions

- If installed in a closed or multi-unit rack assembly, the operating ambient temperature of the rack environment may be greater than room ambient. Keep the rack environment temperature at or below the maximum ambient temperature (T_{ma}) specified by the manufacturer of the installed equipment.
- Provide the proper amount of air flow inside the rack as required for safe operation of the equipment.
- Do not create a hazardous condition by mounting the equipment in the rack with an uneven mechanical load.
- When connecting the equipment to the supply circuit, consider the effect that overloading of the circuits might have on over-current protection and supply wiring. Consider all equipment nameplate ratings when addressing this concern.
- Maintain reliable earthing of rack-mounted equipment. Give particular attention to indirect supply connections to the branch circuit (e.g., power strips).

Multiple System Setup

When setting up multiple systems, designate a single bodypack to scan for available frequencies and download them to all the rack units.

The bodypack must be from the same frequency band as all the transmitters.

1. Power on all the rack units. **Turn off the RF.** (This prevents them from interfering with the frequency scan.)

Note: Turn **on** all other wireless or digital devices as they would be during the performance or presentation (so the scan will detect and avoid any interference they generate).

2. Use the bodypack to **scan for a group** by pressing and holding the scan button for **two seconds**. The bodypack displays the group and the number of available channels, and flashes SYNC NOW....

Important: Note the number of available channels. If you have more rack units than available channels, eliminate potential sources of interference and try again, or call Shure Applications for assistance.

3. Sync the bodypack with the first rack unit by aligning the IR windows and pressing sync.
4. Press scan again on the bodypack to find the next available frequency.
5. Sync the bodypack with the next rack unit.
6. Repeat with all the rack units.
7. Sync each performer's bodypack to its respective rack unit by aligning the IR windows and pressing sync. **DO NOT** press scan on the bodypacks.
8. Turn on the RF on all rack units. The systems are ready to use.

Firmware Updates

Firmware is embedded software in each component that controls functionality. Periodically, new versions of firmware are developed to incorporate additional features and enhancements. To take advantage of design improvements, new versions of the firmware can be uploaded and installed using the Shure Update Utility (SUU). Download the SUU from https://www.shure.com/en-US/products/software/shure_update_utility.

Perform the following steps to update the firmware:

CAUTION! Ensure the device has a stable network connection during the update. Do not turn off the device until the update is complete.

1. Connect the device and computer to the same network (set to the same subnet).
2. Open the SUU application.
3. Click the Updates button at the top of the window to open the Download Manager.

Note: This button will be labeled either "Check for updates..." or "[#] updates available"

4. From the Download Manager, select the desired firmware versions.

Tip: The dropdown in the upper right allows you to quickly Select: All or Select: None.

Note: After updating, you may need to clear your browser's cache to display updates to the device's web application.

5. Click Download, and then Close the Download Manager. Downloaded firmware is listed and can be viewed and managed in the Firmware tab.
6. From the Update Devices tab, select the new firmware and press Send Updates to begin the firmware update, which overwrites the existing firmware on the device.

Firmware Versions and Compatibility

The firmware of all Shure devices has the form of MAJOR.MINOR.PATCH.BUILD (e.g., 1.2.14.0). To ensure interoperability, all components from the same model family (including transmitters) should be updated to the same MAJOR and MINOR firmware version numbers (e.g., 1.2.x.x).

Radio Frequency (RF) Settings

Groups & Channels

A wireless audio channel is formed when a receiver and transmitter are tuned to the same frequency. To minimize interference, Shure wireless systems organize RF bands into predefined **groups** and **channels**. A group is a set of compatible frequencies

within a frequency band. A single frequency within a group is a channel. Tune a receiver and transmitter to the best available channel within its group to set up your system.

Use a frequency scan to analyze the RF environment for interference and identify available frequencies. There are three types of scan:

- **Spectrum Scan:** Scan the full RF spectrum for potential sources of interference. From the bodypack menu, select RADIO > SPECTRUM SCAN. Press RUN SCAN to initiate a full scan. Press SPECTRUM to view full results in a graphical display.
- **Channel Scan:** Find the best available groups and channels in your RF environment. [After deploying spectrum scan data](#), initiate a channel scan from the [ADX transmitter](#).
- **Group Scan:** Finds the group with the greatest number of available channels. (Each group contains a set of frequencies that are compatible when operating multiple systems in the same environment.) [After deploying spectrum scan data](#), initiate a group scan from the [ADX transmitter](#).

When performing a frequency scan:

- **Turn off** the RF on the transmitters for the systems you are setting up. (This prevents them from interfering with the frequency scan.)
- **Turn on** potential sources of interference such as other wireless systems or devices, computers, CD players, large LED panels, effects processors, and digital rack equipment so they are operating as they would be during the presentation or performance (so the scan will detect and avoid any interference they generate).

Spectrum Scan

An ADXR can scan the available wireless spectrum, identifying available frequencies and providing a visual overview. To view the results of the spectrum scan on the transmitter, and determine and deploy the best Group and Channel options for your configuration, open the transmitter's Channel or Carrier menu and select Spectrum Scan > Group Scan > Sync Scan from ADXR.



Viewing Spectrum Data

From the Bodypack Receiver

MAIN MENU > RADIO > SPECTRUM SCAN > RECALL

- Adjust the cursor position using the ▼ ▲ keys.
- Press O to open the Functions menu and set the zoom or run a new scan.
- Press X exit the spectrum scan.

From the Rack Transmitter

After performing a spectrum scan on the receiver, open the transmitter's Radio menu and select Spectrum Scan > Sync Scan from ADXR. Align the IR windows between the transmitter and the receiver so that the IR LED illuminates.

Use Spectrum Scan > View Scan to view the results in more detail:

- Push the control knob to open Scan Tools and select Cursor. Move the cursor using the control wheel.
- Frequency and power of signal at the cursor position is displayed at the top of the screen.
- Push the control knob to open Scan Tools and select Zoom. Use the control wheel to zoom in and out.

Group Scan

Group scan automatically finds all available frequencies within a group. Available frequencies can be automatically deployed to receiver channels and other networked components.

1. From the Channel or Carrier menu: Spectrum Scan > Group Scan.
2. Press Scan to analyze the available spectrum.
3. When the scan is complete, use the control wheel to select the group that best meets your needs.
4. Press Deploy to assign the frequencies in the selected group to components on the network.

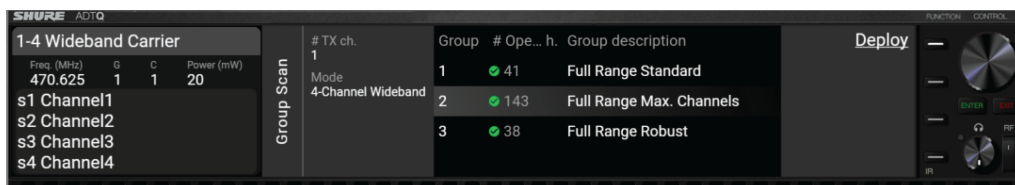

Channel Scan

Channel scan automatically scans a group to find available frequencies.

1. From the Channel or Carrier menu: Spectrum Scan > Channel Scan.
2. Use the control wheel to select a group, and press Scan to start.
3. When the scan is complete, use the control wheel to select a channel and press ENTER to confirm your frequency selection.

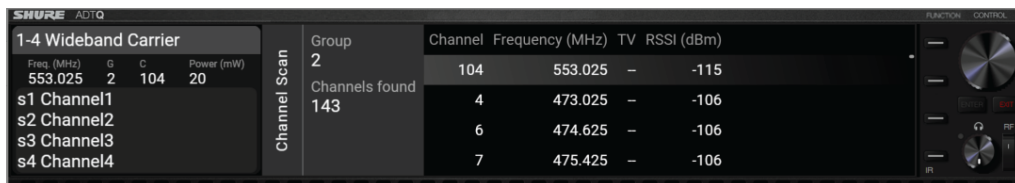

Sync

Syncing establishes a link between a compatible transmitter and receiver to allow sharing of key data and RF audio.

Open the transmitter's Channel Settings menu and press the Sync function button. Align the IR windows between the transmitter and the receiver so that the IR LED illuminates. When complete, Sync Success appears on the transmitter.

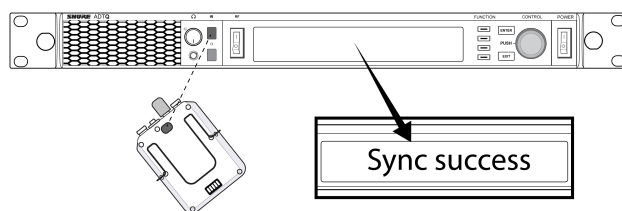

Additional sync options are available on the transmitter under Channel Settings > Receivers.

Programming Transmitters Using IR Presets

Configuring IR presets allow all transmitter parameters to be automatically set from the receiver during an IR sync.

Individual parameters can be configured in the IR Presets menu. Each preset has the default value of No Change, which leave that setting unchanged by an IR sync.

1. Select from the channel menu: IR Presets
2. Use the control wheel to select and edit parameters from the preset list. Select No Change to keep existing settings.
3. Press ENTER to save.

Setting the Frequency Manually

The ADXR can be manually tuned to a specific group, channel, or frequency. In wideband transmission modes, the subchannel index can also be set manually.

Note: When an ADXR is linked, manual frequency updates must be made on the transmitter.

1. Navigate to the Radio menu and select Freq.
2. Scroll to select G: and C: to edit the group and channel, or select the frequency parameter (MHz). When editing the frequency, press O once to edit the first 3 digits, or twice to edit the last 3 digits.
3. Use the \wedge \vee buttons to adjust the group, channel, or frequency.
4. Press O to save, and then press X when finished.

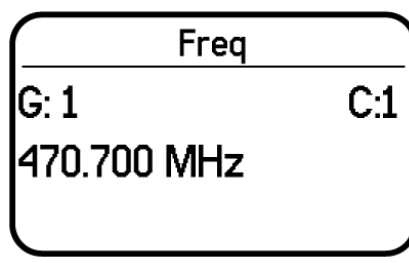

Requesting a New Frequency from a Spectrum Manager

When you have assigned a Spectrum Manager as a frequency server for the receiver, you can use the New Frequency menu option to quickly change to a clear frequency. The New Frequency option is only available when you have assigned a Spectrum Manager as a frequency server for the receiver.

Caution: After a new frequency has been assigned, the frequency of any linked transmitters must be updated manually or by using IR sync.

1. Navigate to a channel menu, and then select New Frequency.
2. Select ENTER to get a new frequency from the Spectrum Manager.

Assigning Receivers to Receiver Slots

Each transmitter contains 8 slots where receivers can be linked. The transmitter will keep key settings, such as frequency, channel name, and device ID, for each linked receiver. Use the ADTD/Q menu to view detailed status and make changes to the receiver settings remotely.



From the Channel menu, select Receivers and use the control wheel to select a slot.

- Unlink: Remove the assigned receiver from the selected slot.
- Browse: Scan available devices on the ShowLink network to assign to the selected slot.
- Sync (No Link): IR sync channel name, frequency, sync presets and encryption key without assigning to a receiver slot.

- Sync: IR sync and assign the receiver to the selected slot.

Channel Quality Meter

The home screen displays a channel quality meter, providing a visual indicator of the signal-to-noise ratio of the RF signal. When the RF signal is strong with a low level of noise, all five segments of the meter are filled or the number 5 is displayed.

- Meter:

- Number:

If the noise ratio increases, the fewer segments are displayed or the quality number drops. Low levels of channel quality provide an early warning of potential problems, allowing you to switch to a clear frequency.

RF System Gain

The RF System Gain monitor displays the calculated RF output power, post external combiners, as RF power and connections to external combiners are adjusted. Transmitters provide additional power based on the RF power level and operational preset to compensate for passive combiner loss.

RF Mute

RF mute prevents transmission of the audio by suppressing the RF signal. Set this using the RF switch on the transmitter's front panel:

- I: RF signal is active
- O: RF signal is disabled

Squelch

In Analog FM transmission modes, Squelch mutes audio output from the bodypack when the RF signal becomes noisy. While squelch is activated, the blue LED on the bodypack turns off.

For most installations, squelch does not need adjustment, and it keeps the performer from hearing hiss or noise bursts if the RF signal becomes compromised. However, in congested RF environments or in close proximity to sources of RF interference (such as large LED video panels), the squelch may need to be lowered to prevent excessive audio dropouts. With lower squelch settings, the performer may hear more noise or hiss, but will experience fewer audio dropouts.



Important: Before lowering squelch, first try to eliminate the problem by finding the best set of frequencies for your installation and removing potential sources of interference.

Caution: Turning off or lowering the squelch setting can increase the noise level and cause discomfort to the performer:

- Do not lower the squelch setting unless absolutely necessary.
- Turn earphone volume to the lowest setting before adjusting squelch.
- Do not change the squelch setting during a performance.
- Turn up the transmitter level setting to make noise or hiss less noticeable.

Squelch Settings

HIGH (NORMAL)		Default factory setting.
MID		Moderately decreases the signal-to-noise ratio required to squelch the receiver.
LOW		Greatly decreases the noise squelch threshold.

PILOT ONLY*		Turns off noise squelch leaving only pilot squelch on.
NO SQUELCH*		Turns off noise and pilot tone squelch. (Sometimes used as a debugging tool by monitor engineers or RF coordinators to "listen" to the RF environment.)

* Symbol appears in display window.

Operational Presets

Axient Digital PSM transmitters offer different presets for RF transmission, spatial diversity, and internal antenna combining to provide the best configuration for your use case.

Operational presets are a device-level setting, meaning the transmitter uses the same parameters for all channels. However, you can combine different operational presets across multiple transmitter devices—for example, configuring one transmitter to use Narrowband, spatial diversity for optimal RF performance, and another transmitter in Multi-channel wideband to maximize overall channel count.

Note: Operational preset availability for Axient Digital PSM varies by region.

Transmission Modes

Multi-Channel Wideband

Digital transmission, where multiple stereo audio channels are supported on a single frequency for optimal spectral efficiency. Fewer active RF antenna ports per transmitter reduces external combiner needs, while fewer frequencies simplifies RF coordination and reduces intermodulation, improving the noise floor for the entire wireless configuration. Combine with spatial diversity for the best balance of RF signal quality and spectral efficiency.

Frequency updates affect all associated stereo audio channels, and RF output power is divided across each stereo subchannel.

Narrowband

Digital transmission, where each stereo audio channel is supported by its own dedicated frequency. This allows carriers to squeeze into tight parts of available spectrum, and can increase overall broadcast distance. Combine with spatial diversity for the best RF performance.

Frequency updates only affect a single stereo audio channel.

Analog FM

Analog transmission, where each stereo audio channel is supported by its own dedicated frequency. Analog FM offers comparable broadcast distance and lower latency compared to Narrowband, but also less spectral efficiency.

Frequency updates only affect a single stereo audio channel.

	Multi-Channel Wideband	Narrowband	Analog FM
Spectral Efficiency	28 channels per 6 MHz	17 channels per 6 MHz	9 channels per 6 MHz
Latency	< 2.9 ms	< 2.9 ms	1.29 ms
Spatial Diversity	Yes	Yes	No

	Multi-Channel Wideband	Narrowband	Analog FM
Encryption	Yes	Yes	No

Spatial Diversity

Spatial diversity improves overall RF performance, even when operating at lower RF output power. By employing two transmit antennas per audio channel, spatial diversity provides advance protection against multipath interference and RF noise for digital transmission modes.

In Narrowband transmission mode, spatial diversity reduces the number of available channels by half. Spatial diversity has no impact to the channel count density per transmitter in Multi-Channel Wideband transmission mode.

Note: Spatial diversity is intended only for systems using 2 transmit antennas. Single-antenna systems will experience a loss in RF output power at no benefit to the overall RF performance.

Internal Antenna Combining

Internal antenna combining allows multiple RF signals to be combined within the transmitter. For transmission modes with multiple RF frequencies per transmitter, such as narrowband or analog FM, choosing an operational preset that includes internal antenna combining consolidates all frequencies to a single RF output, reducing or eliminating the need for external combiners.

Note: Depending on region, transmitters with internal antenna combining enabled may operate at lower RF output power.

Preset Diagrams

Multi-channel wideband, spatial diversity

Provides the best balance between RF signal quality and spectral efficiency.

ADTQ: 4 audio mixes on 1 carrier frequency output simultaneously across antennas: A, D

ADTD: 2 audio mixes on 1 carrier frequency output simultaneously across antennas: A, B

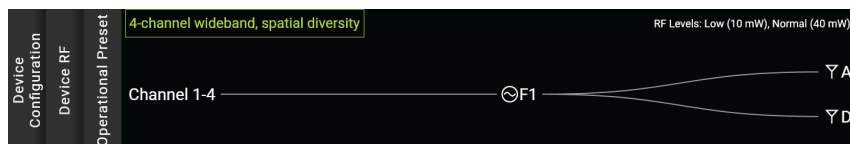

Multi-channel wideband

ADTQ: 4 audio mixes on 1 carrier frequency output on 1 antenna: A

ADTD: 2 audio mixes on 1 carrier frequency output on 1 antenna: A



Narrowband

Offers increased broadcast distance.

ADTQ: 4 audio mixes on 4 carrier frequencies output on antennas: F1 on A, F2 on B, F3 on C, F4 on D

ADTD: 2 audio mixes on 2 carrier frequencies output on antennas: F1 on A, F2 on B



Narrowband, combined

ADTQ: 4 audio mixes on 4 carrier frequencies output on antenna: A

ADTD: 2 audio mixes on 2 carrier frequencies output on antenna: A



Narrowband, spatial diversity

Allows best-quality RF performance, at the cost of half the total channel channel count per transmitter.

ADTQ: 2 audio mixes on 2 carrier frequencies output simultaneously across 2 antennas: F1 on A, C, F2 on B, D

ADTD: 1 audio mix on 1 carrier frequencies output simultaneously across 2 antennas: A, B

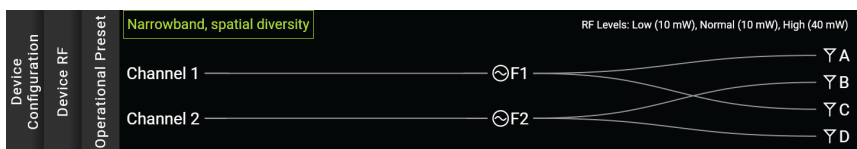

Narrowband, spatial diversity, combined

ADTQ: 2 audio mixes on 2 carrier frequencies output simultaneously across 2 antennas: A, D

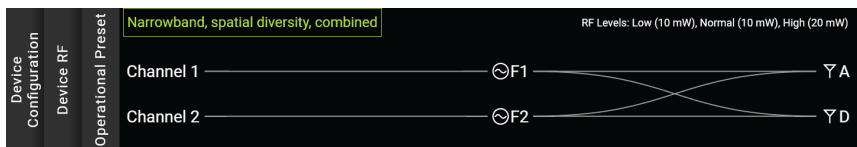

Analog FM

Lower latency than Narrowband, but at the cost of spectral efficiency.

ADTQ: 4 audio mixes on 4 carrier frequencies output on antennas: F1 on A, F2 on B, F3 on C, F4 on D

ADTD: 2 audio mixes on 2 carrier frequencies output on antennas: F1 on A, F2 on B



Analog FM, combined

ADTQ: 4 audio mixes on 4 carrier frequencies output on antenna: A

ADTD: 2 audio mixes on 2 carrier frequencies output on antenna: A



Combined System Diagrams

The AD8C antenna combiner passively combines RF outputs from multiple wireless IEM transmitters. It features selectable 1× (8:1) or 2× (4:1) combining, and automatically compensates for combiner loss by increasing power from ADTQ/ADTD transmitters.

Note: Digital wireless technology naturally minimizes intermods from multiple transmit antennas, compared to analog FM hardware. To optimize RF output power, use the AD8C's 4:1 mode when logistically possible.

The following system diagrams illustrate potential use-cases for connecting your Axient Digital PSM system using an AD8C antenna combiner. For best results, we recommend the following guidelines:

- Maximum combiner level of 4:1 for digital transmission modes, and 8:1 for analog transmission.
- Antennas transmitting different RF carriers should be placed close together, to ensure similar coverage areas.

For more help on system configuration, please contact your local service representative.

Wideband, Spatial Diversity

Two Antennas

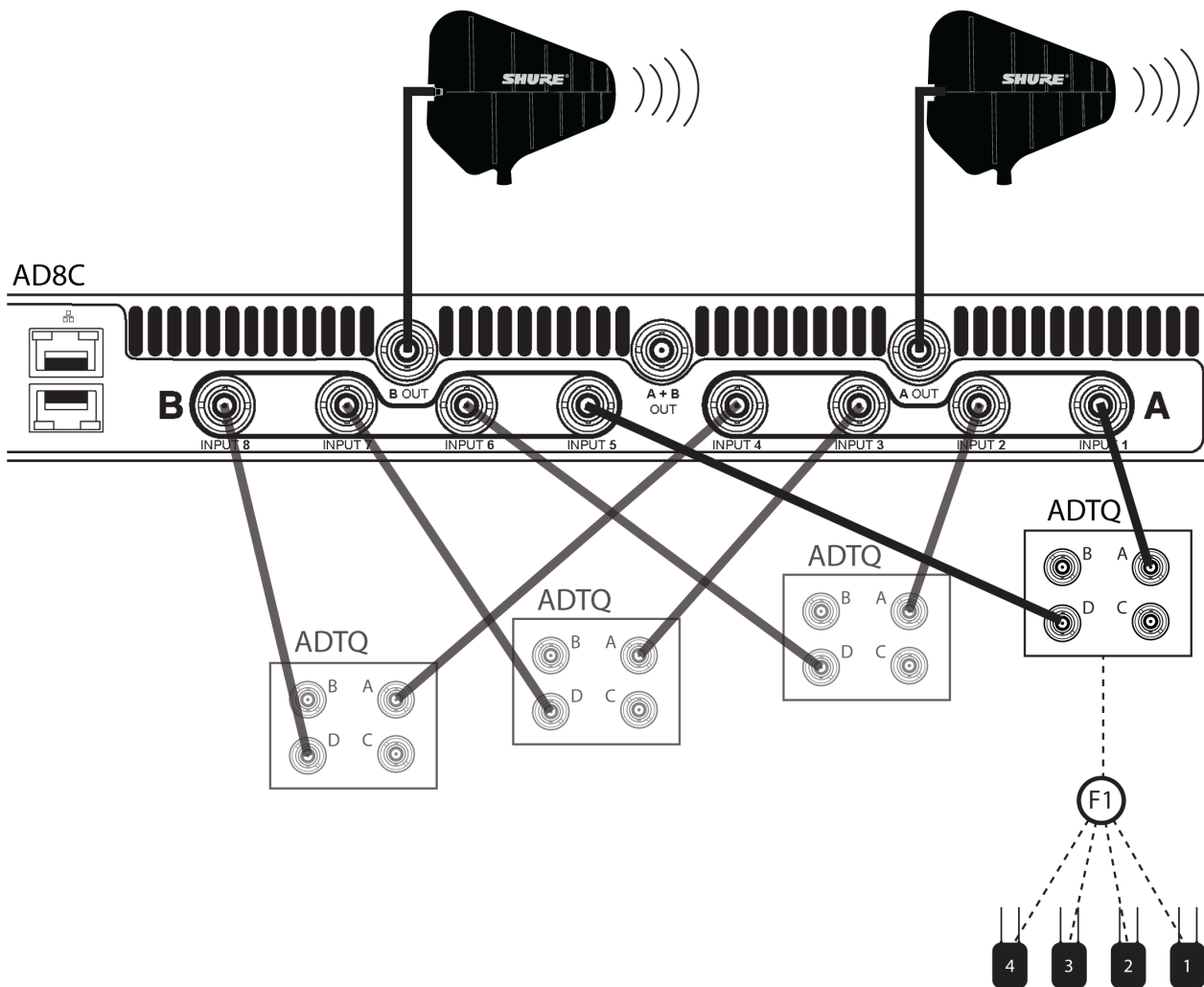

Max. Channel Count	32 (4× ADTQ)16 (4× ADTD)
Combiners	1× AD8C @ 4:1 (-8 dB)

Wideband One Antenna

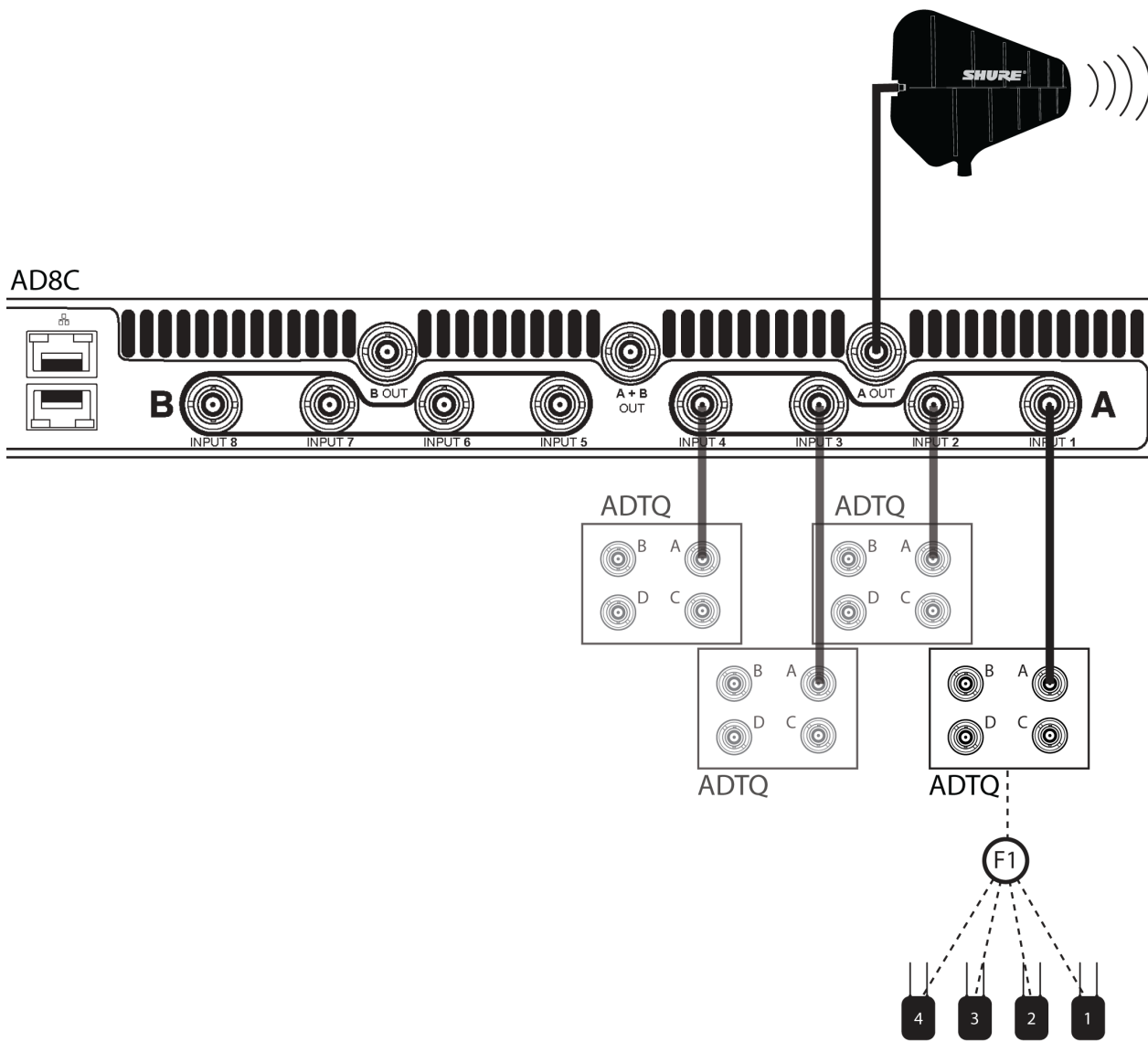

Max. Channel Count	16 (4× ADTQ)16 (4× ADTD)
Combiners	1× AD8C @ 4:1 (-8 dB)

Note: Channel count can be doubled by utilizing the remaining AD8C 4:1 RF inputs and adding a second transmit antenna.

Narrowband One Antenna

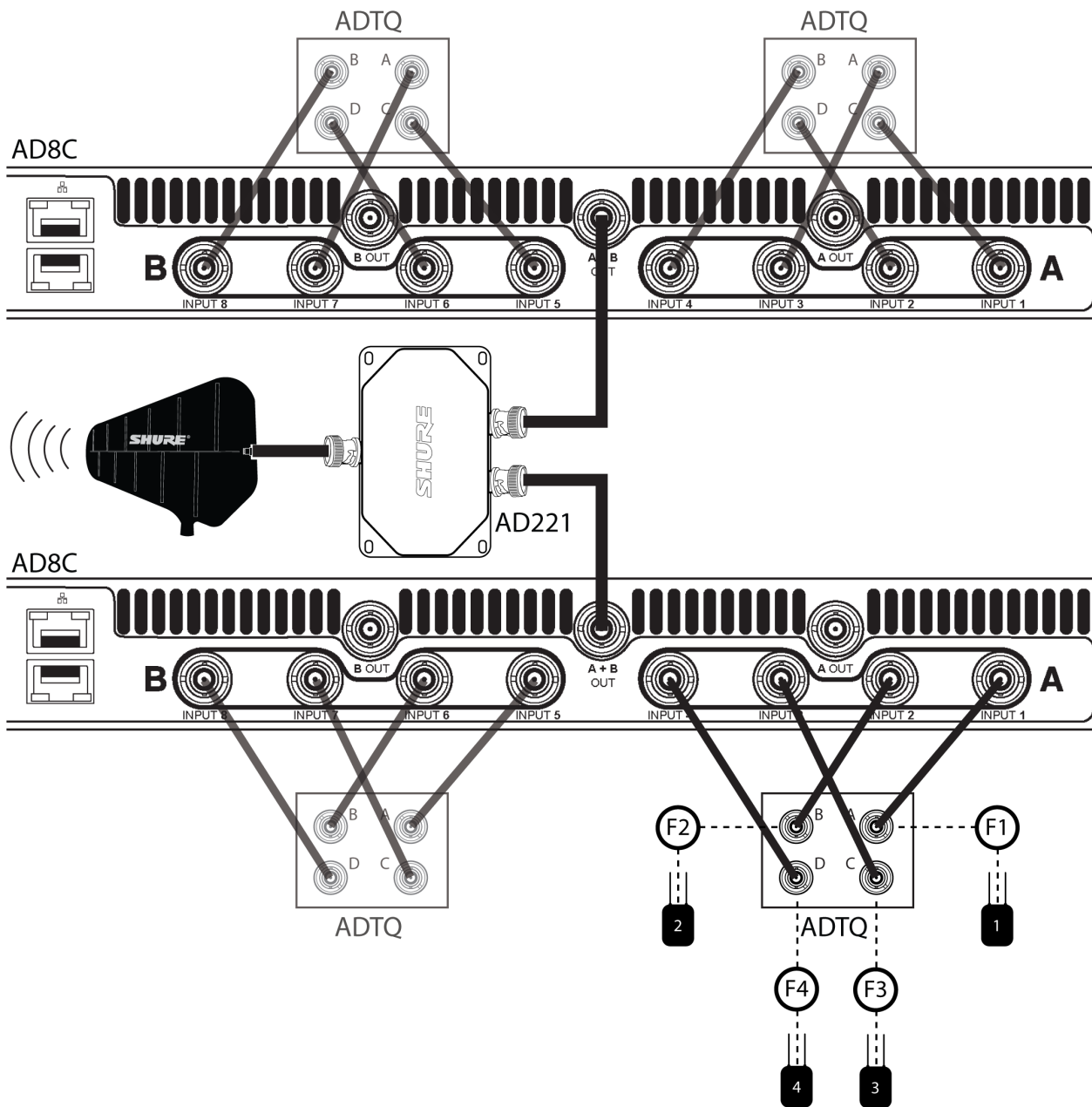

Max. Channel Count	16 (4× ADTQ) 16 (8× ADTD)
Combiners	2× AD8C @ 8:11× AD221 @ 2:1
Combiner Level	16:1 (-15 dB)

Note: Due to passive combiner loss, this configuration is only recommended when operating at low RF output power.

Two Antennas

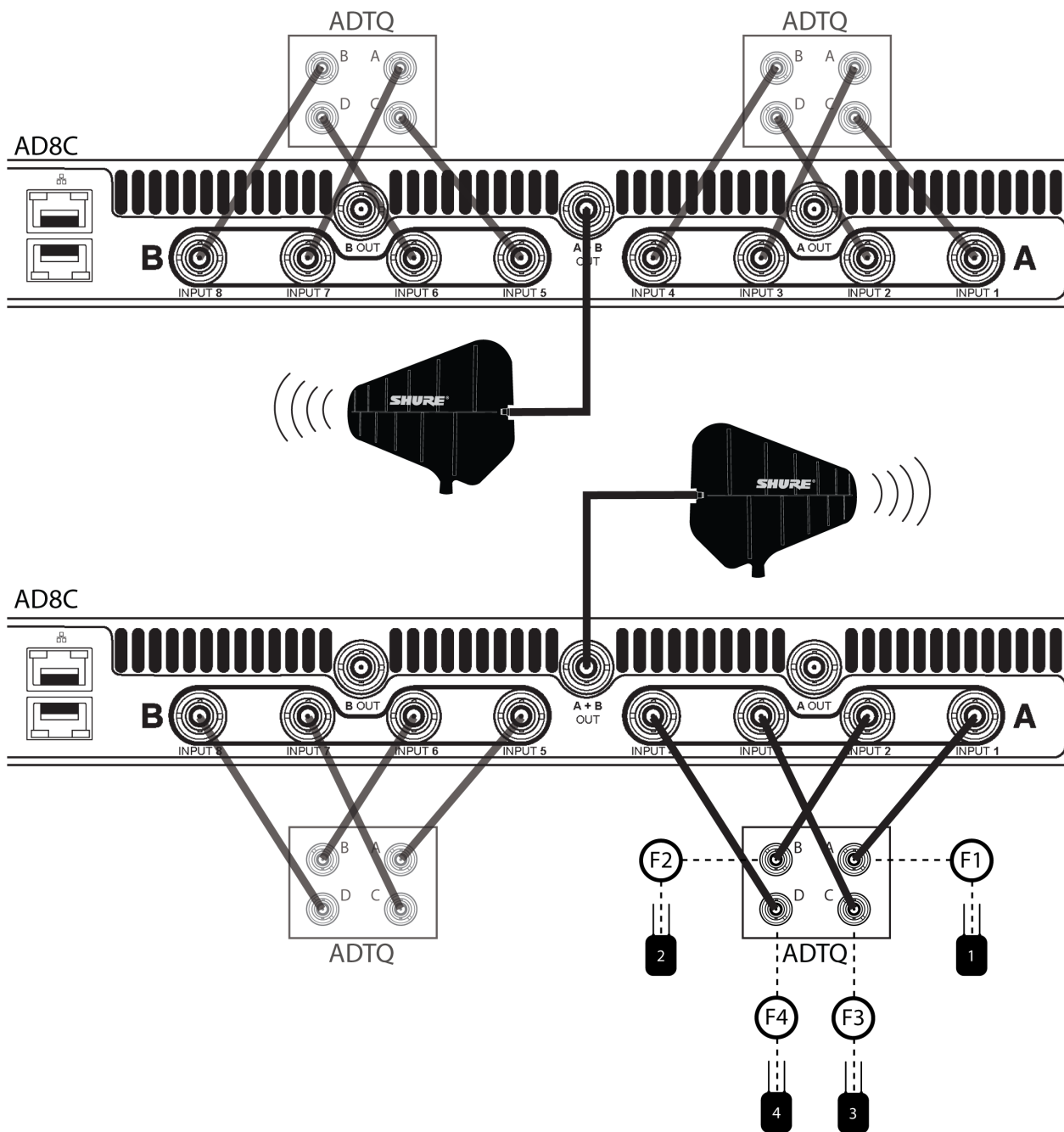

Max. Channel Count	16 (4× ADTQ) 16 (8× ADTD)
Combiners	1× AD8C @ 8:1 (-11 dB)

Four Antennas

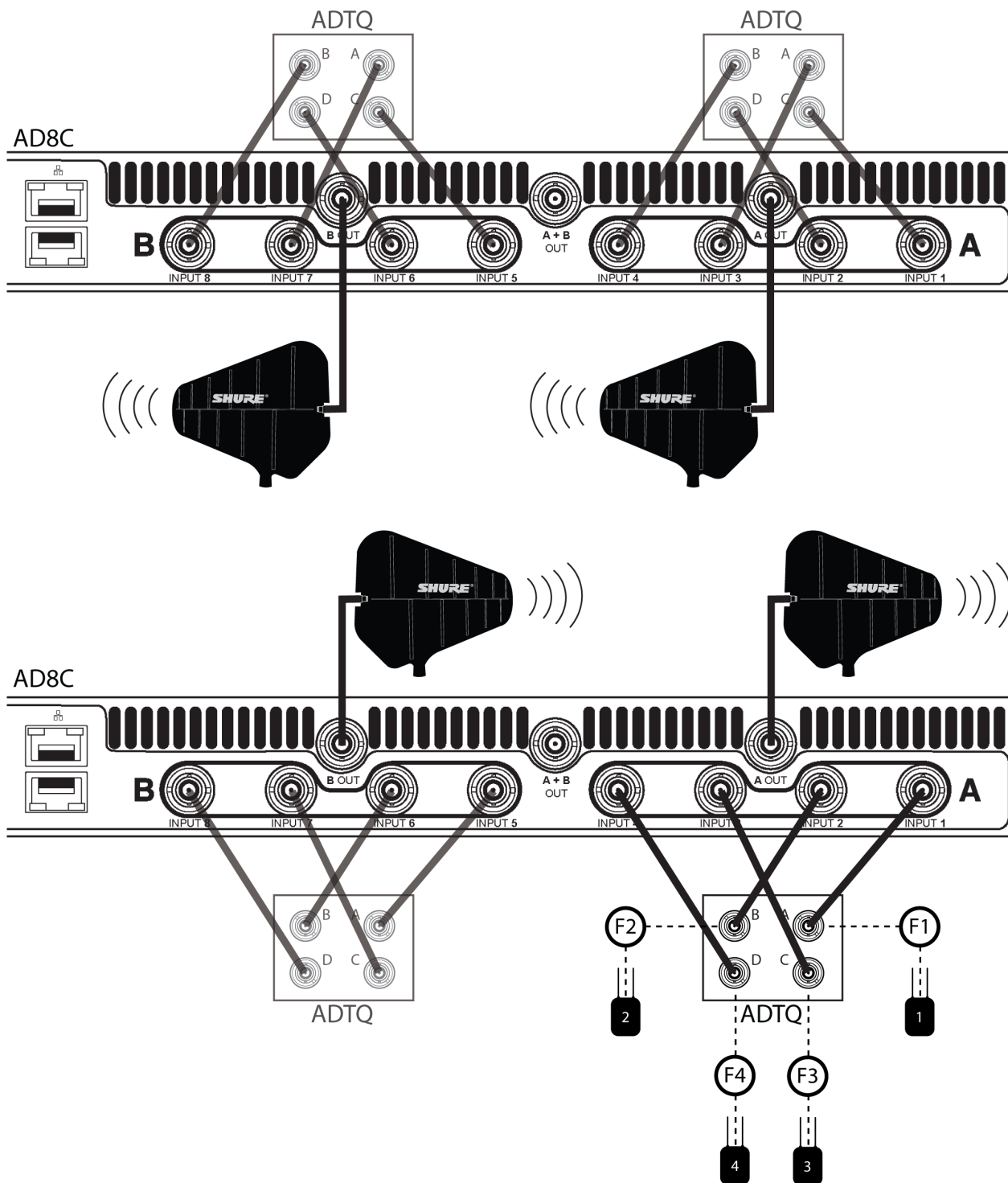

Transmitters	4× ADTQ
Combiners	2× AD8C @ 4:1 (-8 dB)

Note: Recommended for access to greater RF power.

Narrowband, Combined One Antenna

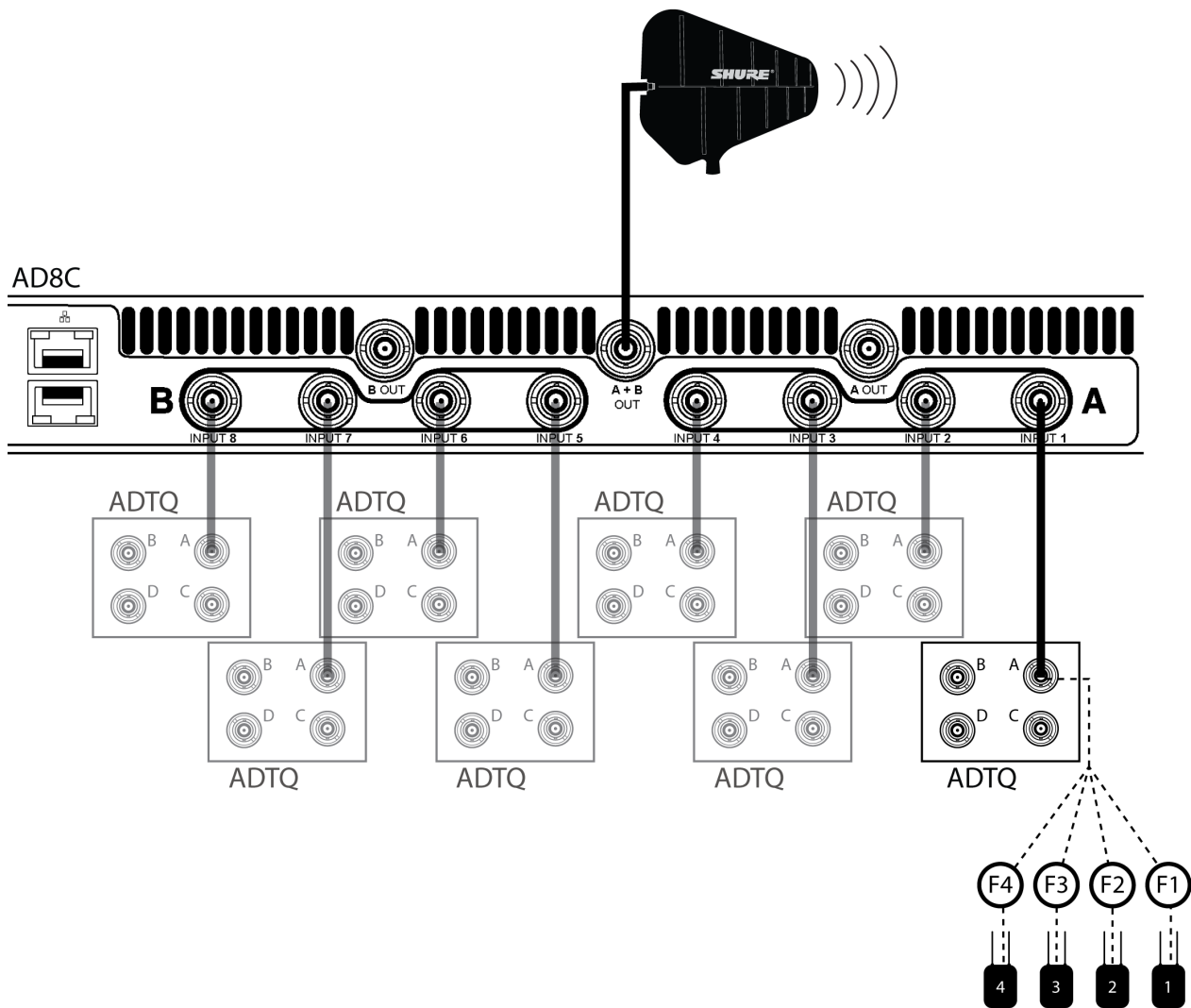

Max. Channel Count	32 (8× ADTQ)16 (8× ADTD)
Combiners	1× AD8C @ 8:1 (-11 dB)

Note: Due to passive combiner loss, this configuration is only recommended when operating at low RF output power.

Two Antennas

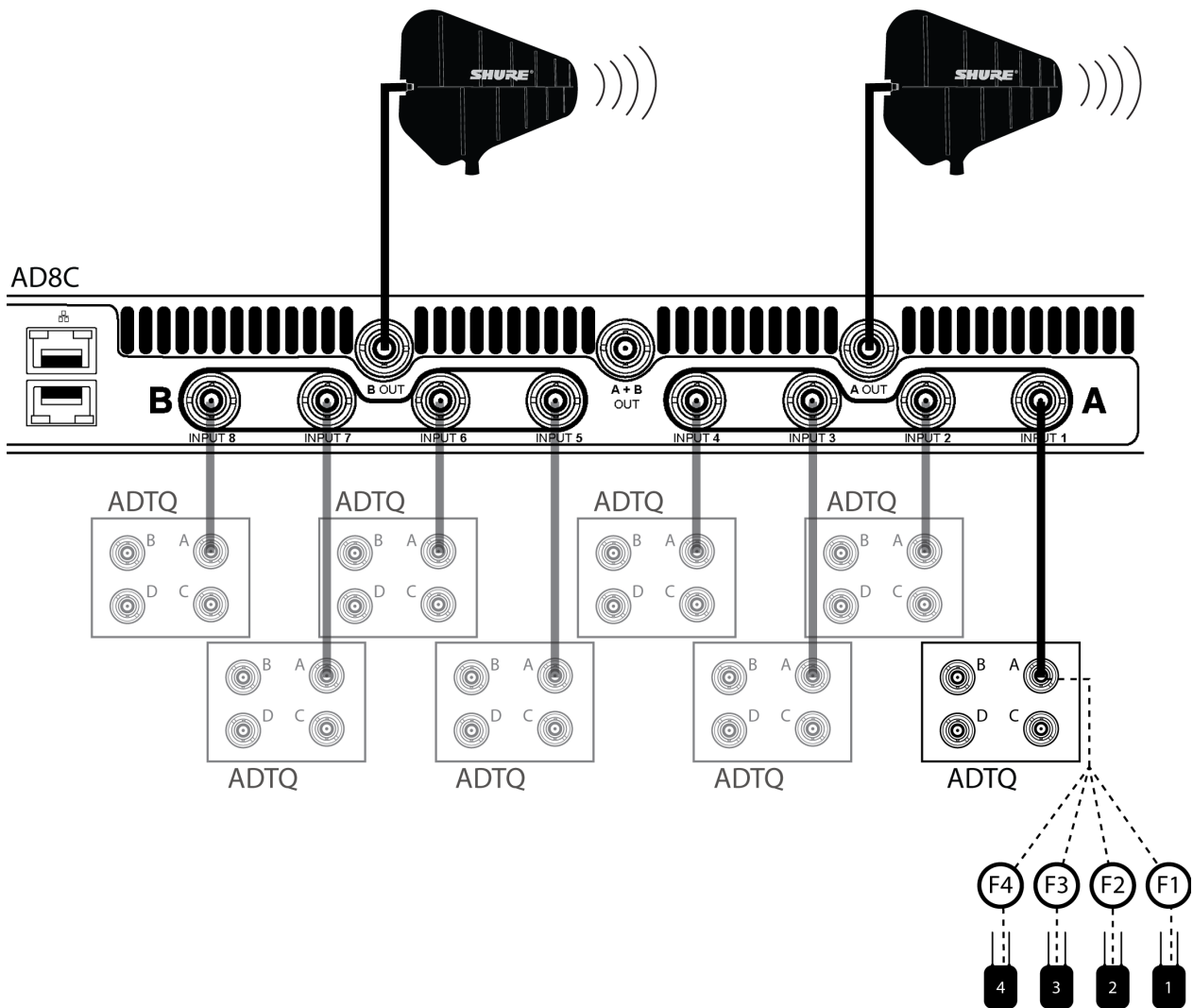

Max. Channel Count	32 (8× ADTQ)16 (8× ADTD)
Combiners	1× AD8C @ 4:1 (-8 dB)

Narrowband, Spatial Diversity

Two Antennas

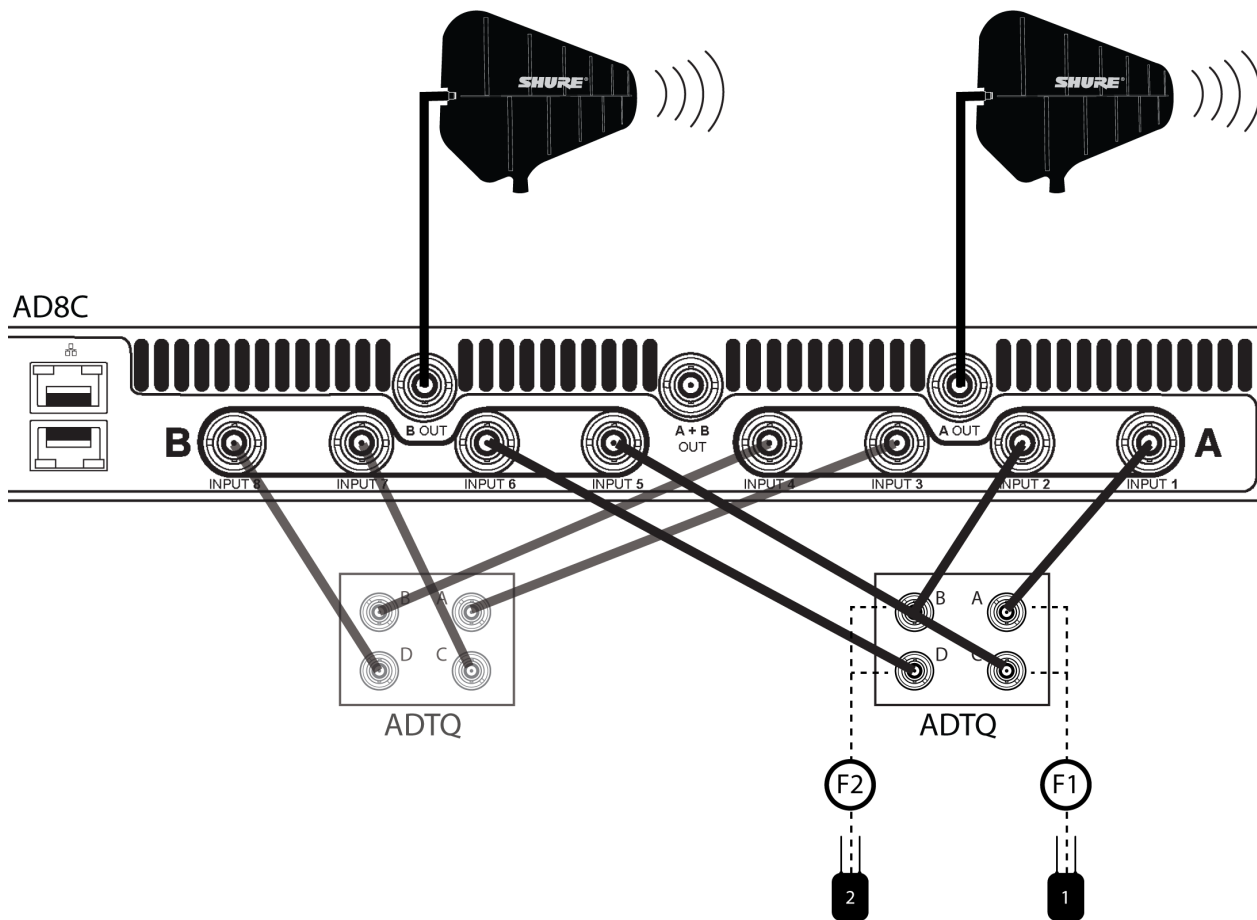

Max. Channel Count	4 (2× ADTQ) 4 (4× ADTD)
Combiners	1× AD8C @ 4:1 (-8 dB)

Narrowband, Spatial Diversity, Combined Two Antennas

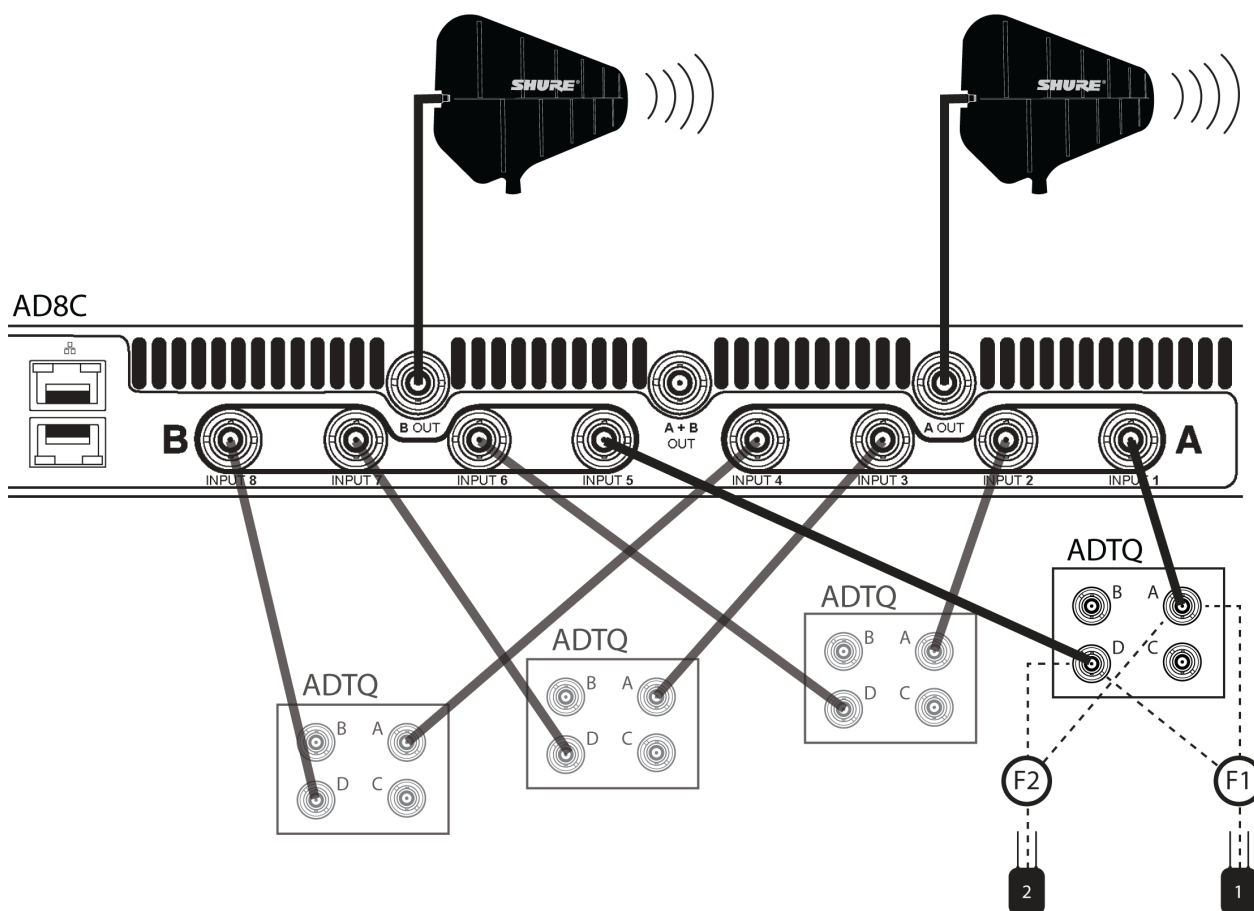

Max. Channel Count	8 (4× ADTQ)8 (4× ADTD)
Combiners	1× AD8C @ 4:1 (-8 dB)

Note: Internal antenna combining increases channel count, but decreases RF output power.

ShowLink Remote Control

A ShowLink network allows you to remotely monitor and adjust settings for portable devices. For devices with ShowLink, you can monitor the battery percentage, channel quality, frequency assignments and audio settings, in real time, without ever leaving the control booth.

What is ShowLink?

ShowLink is a network that carries wireless signals that enable remote control of certain Shure wireless transmitters and receivers.

ShowLink operates in the 2.4 GHz portion of the RF spectrum and transmits parameter data such as RF frequency data, gain settings, and device names. ShowLink does not transmit audio, and you don't need a ShowLink network in order to connect a transmitter and receiver. Any loss of ShowLink control will not affect the audio signal in any way.

To use ShowLink, you need a ShowLink access point and ShowLink-enabled wireless devices. Establish a ShowLink network via IR sync. Map the boundaries of a ShowLink coverage area using ShowLink test in the receiver menu.

How ShowLink Works

ShowLink channels operate in the 2.40 to 2.484 GHz portion of the RF spectrum in accordance with the IEEE 802.15.4 protocol. Devices that share the 2.4 GHz spectrum, including Wi-Fi, are manufactured to efficiently share the spectrum and cause minimal interference. Both ShowLink and Wi-Fi use "listen before talk" technology to transmit short message packets only when needed to conserve bandwidth. Available spectrum, low interference, and global availability make the 2.4 GHz spectrum an ideal choice for hosting ShowLink channels.

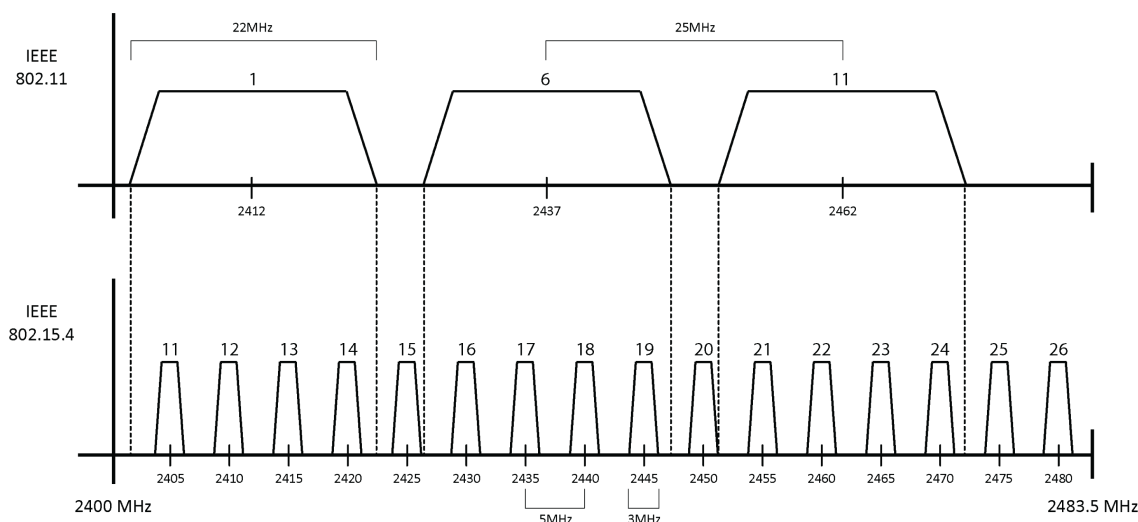

Channel Agility to Avoid Interference

To ensure reliable communication, the access point contains an internal scanning radio that analyzes the 2.4 GHz spectrum hundreds of times per second. If the scanning radio detects interference, the access point automatically switches to a clear channel. This is sometimes referred to as "channel agility." All transmitters associated with the access point will continue to communicate uninterrupted on the new ShowLink channel.

ShowLink Test

The ShowLink Test is a tool to find the boundaries of the ShowLink coverage area. When the ShowLink test is activated, a five-bar display indicating the link quality is shown on the screen. As the bodypack moves away from the access point, the number of bars will decrease. ShowLink control is maintained as long as 1 bar is displayed.

If the bodypack is beyond the coverage range, ShowLink control will not be possible. However, the audio signal will not be affected or interrupted as long as the bodypack is within range of the RF signal.

To improve coverage, adjust the location of your access points or place additional access points to extend coverage.

To activate the ShowLink Test:

1. From the Utilities menu, navigate to SL Test.
2. Press the O button to start the test and walk the bodypack around the coverage area. Monitor the number of bars displayed and the state of the ShowLink icon. Coverage boundaries are indicated by 0 bars displayed or the ShowLink icon is empty.

3. Press the X button to exit the ShowLink test.

Tip: During a ShowLink test, press O (enter) to drop a marker in Wireless Workbench®.

Create a ShowLink Network

Connect a ShowLink access point to your transmitter's network using a Cat 5e Ethernet cable. See the [AD610 user guide](#) for specifications, menu paths, and other information about the AD610 access point.

When a link has been formed, the ShowLink icon  appears next to the channel name on the transmitter screen to indicate the connection.

The ShowLink icon  also appears on the display of a linked transmitter and receiver to indicate that the bodypack is within range of an access point. If a device is beyond the range of the access point, or if the transmitter is offline, the icon will disappear, indicating a loss of ShowLink control.

ShowLink Network ID

Unlinked ADXR receivers can connect to AD610 ShowLink access points when set to the same ShowLink Network Host ID. (Linked receivers are connected to the same ShowLink network as their transmitter.) This allows remote management of unlinked ADXR receivers, without requiring an IR sync between receiver and transmitter.

Update your AD610 to the latest firmware and download the latest version of Wireless Workbench before connecting your ADXR to the network. Set the 4-character network ID on your AD610, then enter the same network ID on your ADXR under **Utilities > SL Network ID Client**.

To quickly enter the network ID on multiple ADXR receivers, you can enter the network ID on the ADTQ/ADTD transmitter and transfer to bodypacks via IR:

- On the transmitter, go to **Device Config > RX ShowLink Network ID Update**.
- Enter the 4-character network ID, and push the control knob to confirm.
- Select **Tx > Transfer** and push Enter.
- Align the IR window on the ADXR with the window on the transmitter until Success appears.

Note: Only the ShowLink Network ID info is transferred to the ADXR receiver. No other data or program changes are sent during IR sync initiated from the transmitter menu.

Operation

ADTQ/ADTD Wireless Transmitter

The ADTQ quad and ADTD dual transmitters set a new standard in transparent digital audio and maximum spectral efficiency. Groundbreaking performance features include wide tuning, multi-channel wideband transmission, and spatial diversity, ensuring solid performance in the most challenging RF environments. Network control, AES3, AES67, Dante inputs, and internal antenna combining options bring in a new level of management and flexibility to your entire workflow. Compatible with ADXR ShowLink-enabled bodypack receivers.

Menus and Configuration

The Axient Digital PSM transmitter uses an at-a-glance home screen to support multiple channels in a single rack space, as well as three sub-menus for device configuration:

- **Device Menu:** Items in this menu affect the overall performance of the transmitter and apply to all channels globally.
- **Channel Menu:** Select audio input and adjust parameters for each channel, allowing for independent channel configuration. Available options vary based on transmitter configuration.

Note: Check the rear input (Analog/AES3) switch on the back panel when rear inputs are selected.

- **Headphone Menu:** Set up headphone channel selection and limiter thresholds.

Navigation and Controls

Use the function buttons, control wheel, ENTER, and EXIT to navigate to menu choices and to set parameters.

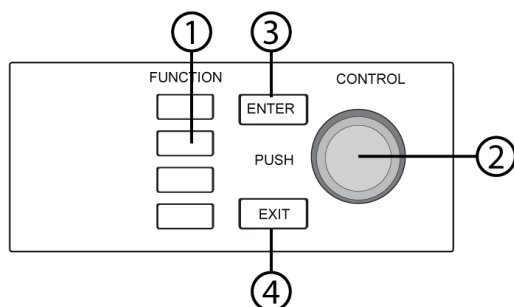

① Function buttons

Press to access editing and configuration options. The buttons are named F1, F2, F3, F4 (from top to bottom) and illuminate when editing options are available.

② Control wheel

- Push to enter a menu
- Push to select a menu item
- Turn to scroll through menu options or to edit a parameter

③ ENTER

Press to confirm or save changes.

④ EXIT

Press to cancel changes and return to main menu.

Home Screen

From the home screen you can view the status of all channels. Rotate the control wheel to highlight the Main menu or any of the available channel menus, and press the control wheel to enter the selected menu.

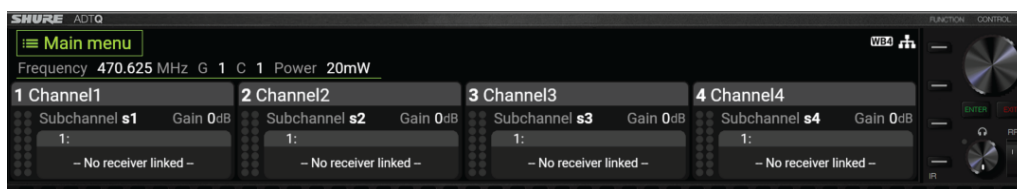

From the Main menu, you can access Device Configuration, Carrier settings (when in wideband), or individual channel menus.



Device Configuration Menu and Parameters

Use the following menu items and parameter settings to configure the receiver at the device level.

Tip: Use the ENTER button to save changes or press EXIT to cancel without saving.

Device Configuration Menu

From the home screen, press the control wheel to access the Device Configuration menu.

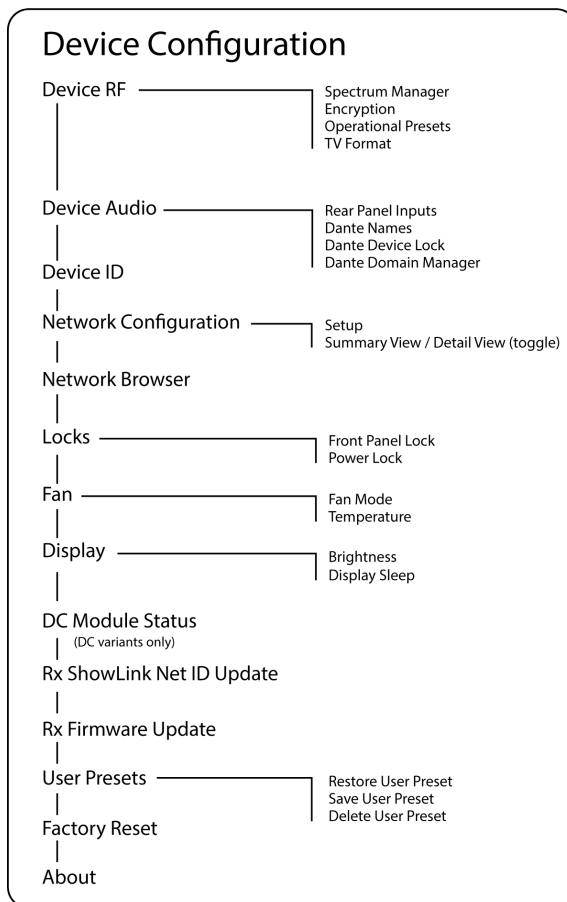

Device Menu Parameters

Device RF

Spectrum Manager

View and select the optional spectrum manager used by this device.

Encryption

Enables encryption of the RF signal.

Operational Presets

Display and configure the transmission mode, frequency diversity, and spatial diversity.

TV Format

Adjust TV bandwidth to match regional standards.

Device Audio

Rear Panel Inputs

View and configure device-level audio settings.

Dante Names

View, edit, and copy names for networked Dante components.

Dante Device Lock

See the status of the Dante device lock.

Dante Domain Manager

See the status of Dante Domain Manager settings.

Device ID

Use the control wheel to assign or edit an ID.

Network Configuration

Configure IP, network, and Dante settings.

Setup

Configure Ethernet ports and IP settings.

Summary View / Detail View (toggle)

Switch between summary and detail views

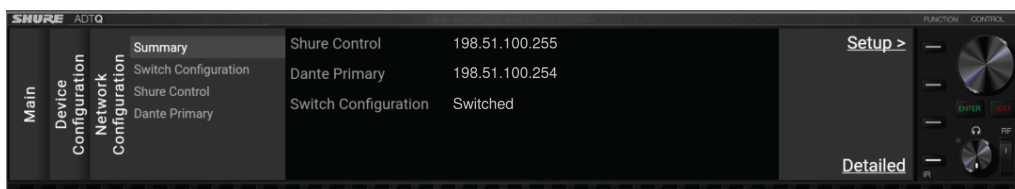

Network Browser

Use the Network Browser utility to view Shure devices on the network.

Show

Display all devices on the network.

Flash All

Flash the front panel LED of all devices on the network to verify connectivity.

F.W. Version

Displays the installed firmware version of the selected network component.

Locks

Front Panel Lock

- Locked
- Unlocked

Power Lock

- Locked
- Unlocked

Fan

Fan Mode

- Auto: The fan will automatically turn on if the receiver temperature rises
- On: The fan will run continuously to offer maximum cooling in warm environments

Temperature

Displays internal receiver temperature.

Display

Brightness

Adjust the brightness of the display.

Display Sleep

Offers options to turn off display and front panel illumination after 10, 30, or 60 seconds.

Tip:

Press any front panel control to interrupt Display Sleep.

DC Module Status

Displays the operational status of the DC Module (if installed).

Rx ShowLink Network ID Update

Set the ShowLink network ID, and copy to an ADXR bodypack via IR.

Note: This does not sync audio settings, link the ADXR to a receiver slot, or change any other setting on the receiver.

Rx Firmware Update

Align receiver IR window and select to update receiver firmware.

User Presets

Create and manage user presets.

- Restore User Preset: Load existing preset
- Save User Preset: Save the current settings as a preset
- Delete User Preset: Delete a preset

Factory Reset

Restores all receiver parameters to factory settings.

About

Provides a detailed list of build specifications and vital statistics for the receiver.

Channel Menu and Parameters

Use the following menus and parameters to configure the receiver channels.

Tip: Use the channel selection buttons to navigate between adjacent channels when configuring menu parameters. Use the ENTER button to save changes or press EXIT to cancel without saving.

Channel Menu Home Screen

The Channel Menu Home Screen allows you to view the settings for a selected channel and details of transmitters linked to that channel. Select a channel number to access the menu.

You can adjust gain, group, channel, and frequency by using the EDIT function button.

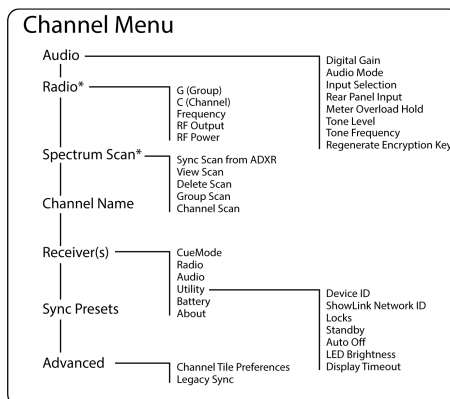
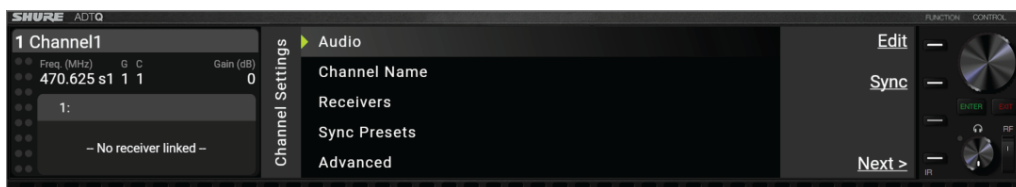

* Located under Carrier Settings when operating in Multi-Channel Wideband mode.

Carrier Settings

In Multi-Channel Wideband transmission mode, Radio and Spectrum Scan are moved to a dedicated Carrier Settings menu. These settings affect the wireless carrier functionality for each group of channels sharing the same carrier.

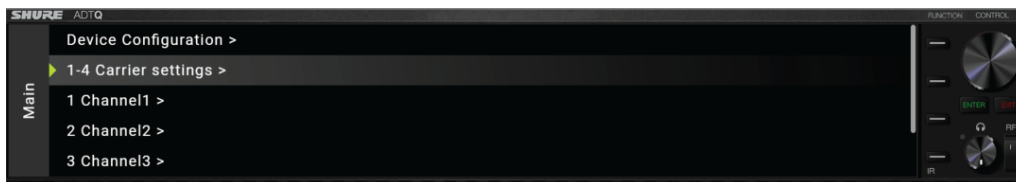

Channel Menu Parameters

Audio

Digital Gain

Adjusts the digital gain in 1 dB increments.

Audio Mode

- Stereo
- Summed to mono

Input Selection

Rear Panel (default) enables:

- Rear Panel Input (indicates which input is routed to the selected channel)
- Analog Sensitivity (when input switch is set to analog)
- AES3 Status / Lock Status / Rate (when input switch is set to AES3)

Dante enables:

- Dante Left / Dante Right (displays channel labels corresponding to L and R inputs)

Meter Overload Hold

Retain overload readings on the audio meter display.

Tone Level

Tone generator level, for testing and troubleshooting.

- Off (default)
- -60 dB to 0 dB, in 6 dB increments

Tone Frequency

Tone generator frequency, 400 Hz (default) to 1000 Hz

Regenerate Encryption Key

When Encryption is enabled, create a new encryption key for this channel.

Note: Linked receivers will receive the new key, re-sync any other receivers to be used on this channel.

Radio

G (Group)

Assign a frequency group.

C (Channel)

Assign a channel.

Frequency

Manually select a frequency.

RF Output

Enable or mute the carrier-level RF output.

RF Power

Set the RF power level for the selected channel:

- Low
- Normal
- High

Spectrum Scan

Sync Scan from ADXR

Imports scan data from a connected bodypack receiver.

View Scan

View saved scan data.

Delete Scan

Delete saved scan data.

Group Scan

Identify the best group and channel in the available spectrum.

Channel Scan

Identify the best channel in the selected group.

Channel Name

Use the control wheel to assign or edit the channel name.

Receivers

Assign and view receiver slots, link or unlink receivers from the selected slots, and edit parameters for linked receivers.



Unlink

Removes a receiver from the selected slot.

Browse

Browse the list of connected receivers, and sync/link the selected receiver to the selected slot.

Sync (no link)

Syncs RF and audio settings *without* assigning a receiver to the selected slot.

Sync

Syncs RF and audio settings, and assigns a receiver to the selected slot.

Sync Presets

Select and edit receiver parameters so they will automatically be set during an IR sync.

Advanced

Channel Tile Preferences

Determine the properties/status information to display on each channel's home page.

Legacy Sync

Display status of the P10 Sync operation when operating in Analog FM transmission mode.

Headphone Monitor

Use the headphone monitor menu to view and adjust parameters for the transmitter's headphone monitor input.



Channel

Select which audio channel is routed to the headphone monitor.

Gain Trim

Pad or boost the headphone gain from -20 dB to +20 dB, in 1 dB steps (default is 0 dB).

Limiter Threshold

Set the limiter to avoid overdriving the headphone amp. Adjustable between 0 dBFS and -30 dBFS.

Device Settings

Assigning a Device ID

Assigning custom names or IDs helps with monitoring and organizing when the receiver is part of a large system.

1. From the Device Configuration menu: Device ID
2. Press and rotate the control wheel to edit the ID.
3. Press ENTER to save.

Assigning a Channel Name

Assigning unique names to each channel helps with identification and organization when the receiver is part of a large system.

1. Select a channel, and then navigate to Channel Name.
2. Press the control wheel to enable editing, and then turn and press the wheel to edit.
3. When finished, press ENTER to save.

Locking and Unlocking the Controls

Use the locking feature to prevent accidental or unauthorized changes to controls and settings. The front panel and power switch can be independently locked or unlocked.

1. From the Device Configuration menu: Locks
2. Use the control wheel to change the lock status for the front panel controls or the power switch.
3. Press ENTER to save.

Adjusting the Display

Brightness and sleep time are adjustable.

The following display options are available:

- Brightness: Low, Medium, High, Auto
- Display Sleep (in seconds): 10, 30, 60, Off

Note: Sleep will only activate from the home screen.

1. Select: Device Configuration > Display
2. Use the control wheel to set the brightness or to set the sleep time.
3. Press ENTER to save.

Display Screen Options

The receiver offers the following display options:

- Brightness: Low, Medium, High, Auto
- Display Sleep: Offers options to turn off display and front panel illumination after 10, 30, or 60 seconds

Tip: Press any front panel control to interrupt Display Sleep.

Encryption

The receiver features Advanced Encryption Standard (AES-256) to ensure that only the receiver that is keyed to the transmitter can monitor the audio content.

Note: When enabled, encryption is applied to all receiver channels. Encryption does not affect Dante audio signals, audio quality, or channel spacing.

1. From the Device Configuration menu: Device RF > Encryption.
2. Use the control wheel to select On.
3. Press ENTER to save.
4. Perform an IR sync to complete the encryption between the transmitter and the receiver. The encryption key icon will appear on the display of both the receiver and the transmitter.

Note:

Any change to the encryption status on the receiver such as enabling/ disabling encryption or requesting a new encryption key, requires a sync to send the settings to the transmitter.

Tip: To remove encryption, use the control wheel to select Off and re-sync the transmitter to clear the encryption.

Cooling Fan Settings

1. From the Device Configuration menu: Fan
2. Select from the following fan setting options:
 - Auto: Automatically turns on to regulate the temperature
 - On: Runs continuously to offer maximum cooling in warm environments

Tip: View the internal temperature on the screen.

Factory Reset

To restore all parameters to factory settings:

1. Main menu > Device Configuration > Factory Reset
2. Select ENTER to restore factory settings.

Audio Settings

Tone Generator

The receiver features a built-in tone generator to provide a continuous audio signal which is useful for sound checks and for system troubleshooting. The level and frequency of the tone are adjustable.

Note: The tone generator enters the signal chain before the system gain. The overall system gain will affect the level of the tone.

1. From the Channel menu:
 - Audio > Tone Level
 - Audio > Tone Frequency
2. Use the control wheel to select a level and frequency for the tone.
3. Press ENTER to save.

Tip: Set the Level to Off to stop the generator.

Headphone Settings

The Axient Digital PSM transmitter includes a headphone jack for monitoring audio signals.

Press the headphone knob or navigate from the main menu: Headphones > Headphone Settings

1. Use the volume knob to control the volume of the headphones.
2. Adjust the limiter threshold to attenuate audio peaks. The audio limiter default setting is -10dB.

Saving Transmitter Settings as User Presets

User presets allow a current transmitter setup to be saved and restored. Presets store all transmitter settings to provide a quick way to configure a transmitter, or switch between several different setups. Up to 4 presets can be stored in device memory.

From the Device Configuration menu, navigate to User Presets and choose one of the following options:

- Restore a User Preset: Use the control wheel to select a previously saved preset

- Save a User Preset: Use the control wheel to save the current receiver settings as a preset
- Delete a User Preset: Use the control wheel to select and delete a preset

ADXR Portable Wireless Receiver

Axient Digital PSM portable wireless receivers provide pristine RF signal and audio quality, ideally suited for the demands of professional touring and live sound applications.

- True digital diversity reception
- Diversity ShowLink-enabled for remote receiver control
- Durable, moisture resistant, slim, lightweight design
- Advanced headphone jack protects against sweat and moisture ingress
- External contacts for docked charging
- Includes 2× SB910 rechargeable batteries

Receiver Controls

Open the battery door to access the control buttons. Use the controls to navigate through parameter menus and change values.

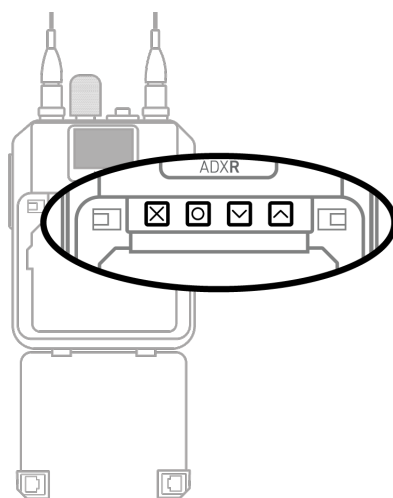

Control	Description
X	Acts as a 'back' button to return to previous menus or parameters without confirming a value change
O	Enters menu screens and confirms parameter changes
VA	Use to scroll through menu screens and to change parameter values

Home Screen Display

The home screen shows receiver information and status.

There are four pieces of information that you can choose to see on the home screen. Set your preference under **Utilities > Home Option**:

- Name
- Frequency
- G/C (group and channel)

- Device ID

By default, the home screen displays Name and Frequency.

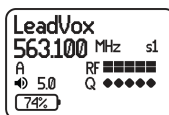

The following icons indicate receiver settings:

Icon	Setting
	Battery charge percent, or bar display.
	Key: Displayed when encryption is enabled. ! indicates an encryption error.
	Lock: Displayed when controls are locked. Icon will flash if access is attempted to a locked control (power or menu).
	ShowLink signal strength displays 0 to 5 bars.
	Link Status: Indicates whether the ADXR is linked to a transmitter.
	Volume: Indicates the level and lock status of the volume knob. An asterisk (*) indicates volume safety is engaged.
	Audio Meter (stereo): Provides real-time audio metering.
	RF Meter: Radio signal strength indicator (RSSI) metering for antenna A (top) and antenna B (bottom).
	Channel Quality: Indicates the channel quality when operating in digital transmission modes.
	CueMode Index: When operating in CueMode, the index number displays in the upper right of the display.

Locking the Interface

Lock transmitter interface controls to prevent accidental or unauthorized changes to parameters. The lock icon appears on the home screen when the interface lock is enabled.

- From the Utilities menu, navigate to Locks and select one of the following lock options:
 - None: The controls are unlocked
 - Power: The power switch is locked
 - Menu: The menu parameters are locked
 - All: The power switch and menu parameters are locked
- Press O to save.

Tip: To quickly unlock a transmitter: Press O twice, select None, and press O.

Menu Parameters

The Main menu organizes the available transmitter parameters into three sub-menus:

- Radio
- Audio
- Utilities

Tip: Use the arrow buttons to scroll between the sub-menus.

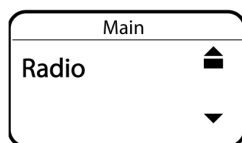

Tips for Editing Menu Parameters

- To access the menu options from the home screen, press O . Use the arrow buttons to access additional menus and parameters.
- A menu parameter will blink when editing is enabled
- To increase, decrease or change a parameter, use the arrow buttons
- To save a menu change, press O
- To exit a menu without saving a change, press X

Menu Map

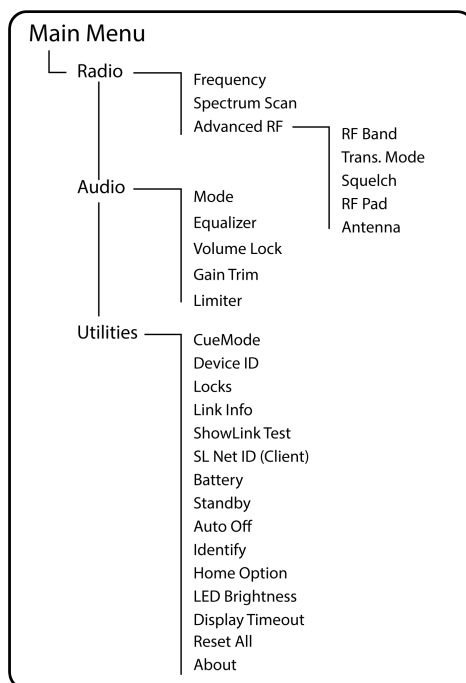

Menu Parameter Descriptions

Radio Menu

Frequency

Press the O button to enable editing of a group (G:) channel (C:) or frequency (MHz). Use the arrow buttons to adjust the values. To edit the frequency, press the O button once to edit the first 3 digits, or twice to edit the second 3 digits.

Spectrum Scan

Performs spectrum scan and displays open frequencies in a graphical interface.

- **Scan Now:** Perform a new spectrum scan
- **Recall:** Display the results of a previously-saved scan (if available)

Advanced RF

Displays advanced RF menu options.

- **RF Band:** Change the operating band

Available frequencies will change, devices may be unlinked

- **Trans. Mode:** Change between available digital (D) and analog (FM) operating modes

Devices will be unlinked and reboot

- **Squelch:** Adjusts the squelch setting (FM operating mode only)
- **RF Pad:** Attenuates antenna signals in 3 dB increments
- **Antenna:** Selection for single- or dual-antenna operation

Audio Menu

Mode

Audio output mode (Stereo, Left, Right)

Equalizer

The parametric equalizer is divided into four frequency bands: LOW, LOW MID, HIGH MID, and HIGH.

- **EQ:** Turn the equalizer on or off
- **Edit:** Adjust the following parameters for each band:
Freq: Select the center frequency of the band to boost/cut
Q: Adjust the width and slope of the frequency band (measured in octaves)
GAIN: Adjustable in 2 dB increments from -12 dB (cut) to +12 dB (boost)

Note: HIGH and LOW are shelf filters, and therefore do not have adjustable Q widths. The HIGH shelf is fixed at 10 kHz; the LOW shelf is fixed at 100 Hz.

- **Reset EQ:** Resets EQ to default values

Volume Lock

The volume is locked to the physical position of the volume knob.

Gain Trim

Pad or boost the headphone gain from -20 dB to +20 dB, in 1 dB steps (default is 0 dB).

Limiter

Set a value (OFF to -48 dB, adjustable in 3 dB increments) to attenuate the highest possible volume level. Turning the volume knob through its entire range of motion still affects volume; the limit simply narrows the range of dB adjustment.

Note: The volume limit does not compress the audio signal

Utilities Menu

CueMode

Enters CueMode and confirms whether device is currently linked.

Device ID

Assign a device ID of up to 31 characters.

Locks

Locks the transmitter controls and power switch.

- **None:** The controls are unlocked
- **Power:** The power switch is locked
- **Menu:** The menu parameters are locked (does not affect volume)
- **All:** The power switch and menu parameters are locked

Link Info

Displays the following information about the link between a transmitter and receiver:

- **Not Linked:** The transmitter is not linked to a receiver
- **Linked:** The transmitter is linked to a receiver. Select Unlink? to free the transmitter from the receiver link.

ShowLink Test

ShowLink test tool to measure the boundaries of ShowLink coverage.

SL Net ID (Client)

Display and configure the ShowLink Network Client ID

Battery

Displays battery information:

- **Battery Life:** Runtime reported in bar display and time (hours:minutes)
- **Health:** Percentage of current battery health
- **Cycle Count:** Total of the number of charging cycles for the installed battery
- **Temperature:** Battery temperature reported in Celsius and Fahrenheit
- **Voltage:** Operating voltage, rounded to 3 decimal places
- **Type:** Alkaline, NiMH, Lithium

Standby

Turns the Audio and RF to standby without powering down the device.

Auto Off

Set the Auto Off timer

Identify

When enabled, Identify flashes the transmitter icon in Wireless Workbench Inventory or Monitor tabs.

Home Option

Determine what information displays on the Home screen:

- Name = channel name
- Freq = operating frequency
- G/C = Group and Channel numbers

LED Brightness

Set the brightness for Power/Battery Status and RF Status LEDs

Note: Does not affect screen brightness

Display Timeout

Set the OLED display timeout.

Reset All

Restores all transmitter parameters to factory settings.

About

Displays information about the transmitter.

Installing Bodypack Antennas

Hand-tighten antennas until secure. Do not use tools.

Shure Rechargeable Batteries

Shure lithium-ion batteries offer a rechargeable option for powering the transmitters. Batteries quickly charge to 50% capacity in one hour and reach full charge within three hours.

Single chargers and multiple bay chargers are available to recharge the Shure batteries.

Caution: Only charge Shure rechargeable batteries with a Shure battery charger.

Checking Battery Info

When using a Shure rechargeable battery, the receiver and transmitter home screens display the battery percentage remaining.

Detailed information for the battery is displayed Battery menu of the transmitter: **Utilities > Battery**

- Battery: The chemistry type of for the installed battery (Shure, Alkaline, Lithium, NiMH)
- Bars: Indicates the number of bars displayed
- Time: Battery runtime
- Charge: Percentage of charge capacity
- Health: Percentage of current battery health
- Cycle Count: Total of the number of charging cycles for the installed battery
- Temperature: Battery temperature reported in Celsius and Fahrenheit

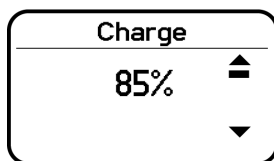

Important Tips for Care and Storage of Shure Rechargeable Batteries

Proper care and storage of Shure batteries results in reliable performance and ensures a long lifetime.

- Always store batteries and transmitters at room temperature
- Ideally, batteries should be charged to approximately 40% of capacity for long-term storage
- Regularly clean the battery contacts (at least every 6 months) with an electrical contact cleaner designed for gold contacts and safe on plastics
- During storage, check batteries every 6 months and recharge to 40% of capacity as needed

For additional rechargeable battery information, visit www.shure.com.

Battery Installation

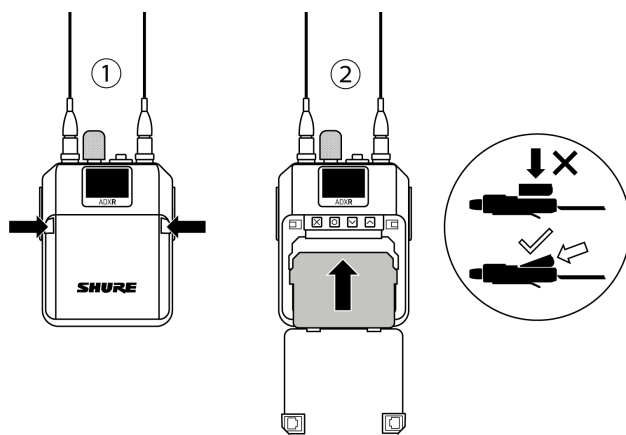

① Accessing the Battery Compartment

Press the door latches and open the battery door.

② Inserting the Battery

Insert the battery, contracts first into the battery compartment. Press down on the tab to fully seat the battery, and then close the battery door.

Tip: To remove the battery, pull up on the tab on the bottom of the battery.

Note: A Battery Hot warning indicates that transmitter battery needs to cool off. Otherwise, the transmitter will shut down. Let the device cool down and then consider swapping the transmitter battery to continue operation.

Identify any possible external heat sources to the transmitter and operate the transmitter away from those external heat sources.

All batteries should be stored and operated away from external heat sources in reasonable temperature conditions for best performance.

CueMode

CueMode allows you to upload the name and frequency settings from multiple rack units and store them as a list on a single bodypack. You can then, at any time, scroll through that list to hear the audio mix from each transmitter, just as each performer does during a show.

CueMode lists are retained even if CueMode is exited, the bodypack is turned off, or batteries are removed.

Note: Set the channel frequency and assign display names for each transmitter **before** creating your CueMode list.

Adding Channels to the CueMode List

Note: The transmitter must be from the same frequency band as the bodypack.

1. Open the battery door and press the enter button.
2. From the main menu, scroll to UTILITIES and press enter. Select CueMode and press enter again.
3. Align IR windows and press sync on the rack unit.

The OLED displays SYNC SUCCESS after frequency and name data are uploaded to the CueMode list. It also displays the CueMode number for that transmitter and the total number of transmitters.

4. Repeat the above step for each transmitter.

Note: Syncing while in CueMode does not change any of the settings on the bodypack.

Auditioning CueMode Mixes

1. Enter CueMode from the UTILITIES menu.
2. Use the ▼ ▲ buttons to scroll through your CueMode list to hear the mixes.

Managing CueMode Mixes

While in CueMode, you can access the following menu by pressing enter:

REPLACE MIX

Select and press sync on a rack unit to upload new data for the current mix (for example, if you have changed the transmitter frequency).

COPY CUES

Use IR sync to copy all mixes to another ADXR.

DELETE MIX

Removes the selected mix.

DELETE ALL

Removes all mixes.

EXIT CUEMODE

Exits CueMode. The bodypack remains on the the last activated Cue settings.

AD8C Antenna Combiner

Menus and Configuration

Combiner settings relate to RF combining and input port termination for specific channels. Device settings affect the overall performance of the combiner, and apply to all channels globally.

Navigation and Controls

Use the function buttons, control wheel, ENTER, and EXIT to navigate to menu choices and to set parameters.

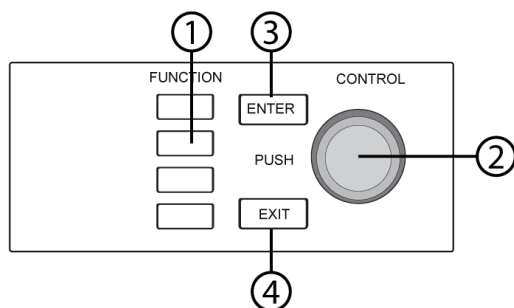

① Function buttons

Press to access editing and configuration options. The buttons are named F1, F2, F3, F4 (from top to bottom) and illuminate when editing options are available.

② Control wheel

- Push to enter a menu
- Push to select a menu item
- Turn to scroll through menu options or to edit a parameter

③ ENTER

Press to confirm or save changes.

④ EXIT

Press to cancel changes and return to main menu.

Home Screen

The home screen displays at-a-glance critical information, including RF input status, network status, hardware lock status, and combiner setting. Use the control wheel to access menus and parameters to configure the combiner.

Tip: Use the channel selection buttons to navigate between adjacent channels when configuring menu parameters. Use the ENTER button to save changes or press EXIT to cancel without saving.

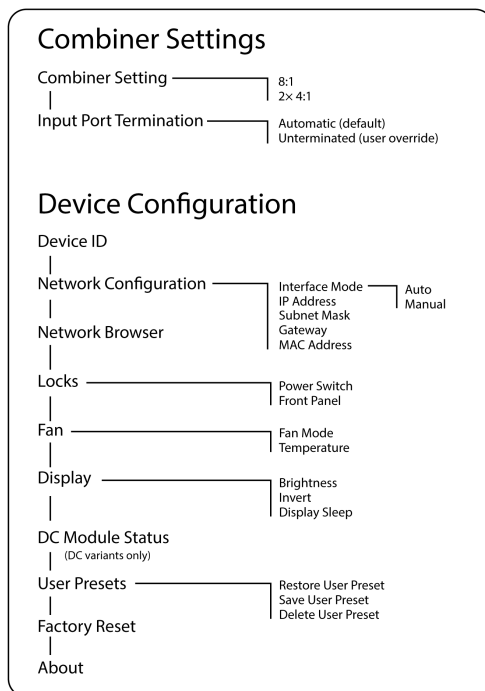

Menu Parameters

Combiner Settings

Combiner Setting

Choose whether the device operates as an 8:1 combiner, or a 2× 4:1 combiner.

Input Port Termination

Port termination is handled automatically by default.

Device Configuration Settings

Device ID

Use the control wheel to assign or edit an ID.

Network Configuration

Choose the interface mode and configure IP and network settings.

Interface Mode: Auto

IP address, subnet mask, gateway and MAC address are automatically configured and view-only.

Interface Mode: Manual

Manually set the IP address, subnet mask and gateway, and view the MAC address.

Network Browser

Use the Network Browser utility to view Shure devices on the network.

Show

Display all devices on the network.

Refresh

Re-scan the network and refresh the onscreen info.

Flash All

Flash the front panel LED of all devices on the network to verify connectivity.

F.W. Version

Displays the installed firmware version of the selected network component.

Locks

Front Panel Lock

- Locked
- Unlocked

Power Lock

- Locked
- Unlocked

Fan

Fan Mode

- Auto: The fan will automatically turn on if the receiver temperature rises
- On: The fan will run continuously to offer maximum cooling in warm environments

Temperature

Displays internal receiver temperature.

Display

Brightness

Adjust the brightness of the display.

Style

Inverts the color of the display.

Display Sleep

Offers options to turn off display and front panel illumination after 10, 30, or 60 seconds.

Tip:

Press any front panel control to interrupt Display Sleep.

DC Module Status

Displays the operational status of the DC Module (if installed).

User Presets

Create and manage user presets.

- Restore User Preset: Load existing preset
- Save User Preset: Save the current settings as a preset

- Delete User Preset: Delete a preset

Factory Reset

Restores all receiver parameters to factory settings.

About

Provides a detailed list of build specifications and vital statistics for the receiver.

Networking

The Axient Digital PSM transmitter features a 4-port network interface. Dante technology provides an integrated solution to monitor digital audio. Dante uses standard IP over Ethernet and safely coexists on the same network as IT and control data. Selectable networking modes route port signals for flexible network setup.

Network Signal Types

The following signal types are supported on the network:

- Shure control: Shure Wireless Workbench software provides comprehensive control for wireless audio systems
- Dante primary: Dante digital audio signals
- Dante secondary: Second copy (redundant) of the Dante primary audio, often used for additional routing options

Guided Network Configuration

Axient Digital PSM offers a guided setup to simplify networking of your gear.

Setup includes the following:

- Switch mode
- Shure control
- Dante primary
- Dante secondary

Networking Modes

The networking mode determines the type of signals that are routed to the ports.

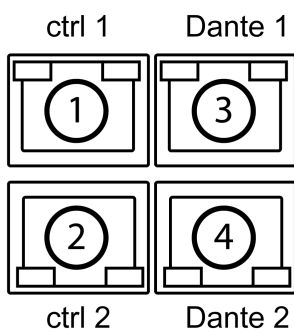

- ① Shure control and Dante primary
- ② Shure control and Dante primary
- ③ Shure control and Dante primary
- ④ Shure control and Dante primary

Split/Redundant Mode Port Signals

- ① Shure control
- ② Shure control
- ③ Dante primary
- ④ Dante secondary

Setting the Switch Mode

1. From the main menu: **Device Configuration > Network Settings > Setup**.
2. Use the control wheel to set the switch mode to **Switched** or **Split Redundant**.
3. Press **ENTER** to save and reboot.

Setting the Interface Mode (IP Address)

An IP address must be assigned to each device in the network to ensure communication and control between components. Valid IP addresses can be assigned automatically using a DHCP server or manually from a list of valid IP addresses. If using Dante audio, a separate Dante IP address must also be assigned to each Dante device.

Automatic

1. If using a DHCP capable Ethernet switch, set the DHCP switch to **ON**.
2. From the **Device Configuration** menu: **Network Settings > Setup > Next**
3. Use the control wheel to set the **Interface Mode** to **Automatic** for **Shure Control**, **Dante Primary**, and **Dante Secondary** (if applicable).
4. When finished, use the **Back** button to return to the home screen.

Manual

1. From the **Device Configuration** menu: **Network Settings > Setup > Next**
2. Use the control wheel to set the **Interface Mode** to **Manual**.
3. Set valid IP addresses, subnet values, and gateways, for **Shure Control**, **Dante Primary**, and **Dante Secondary** (if applicable).
4. When finished, use the **Back** button to return to the home screen.

Accessing the Network with a Computer

You can control and monitor all networked transmitters through a computer running Shure Wireless Workbench software, Version 6 or later. If using the default automatic network setting, make sure your computer is configured for DHCP.

Note: Some security software or firewall settings on your computer can prevent you from connecting to the transmitter. If using firewall software, allow connections on port 2201.

Static IP Addressing

Static IP addressing is also supported. An IP address can be assigned through the network menu (Util > Network > Mode > Manual).

Note: Dual transmitters use a single IP address, which may be set through either LCD interface.

Network Browser

Use the network browser tool to view Shure devices on the network. Access the tool from Main menu > Device - Configuration > Network Browser and use the control wheel to select a device.

Device Configuration	Network Browser	Total devices found	Model	Number found	Identify All
		3	AD4Q-A	1	Refresh
		AD600	1		
		ULXD4Q	1		
				FW version	

Identify All

Flashes the front panel LED of all devices on the network to verify connectivity.

Refresh

Updates the device list.

FW Version

Displays the firmware versions of devices found on the network. Select Model to view the device model.

Tip: Press the control wheel to view the device IDs and IP addresses of these devices.

Connecting Transmitters

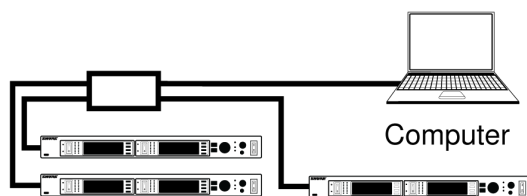

Router with DHCP

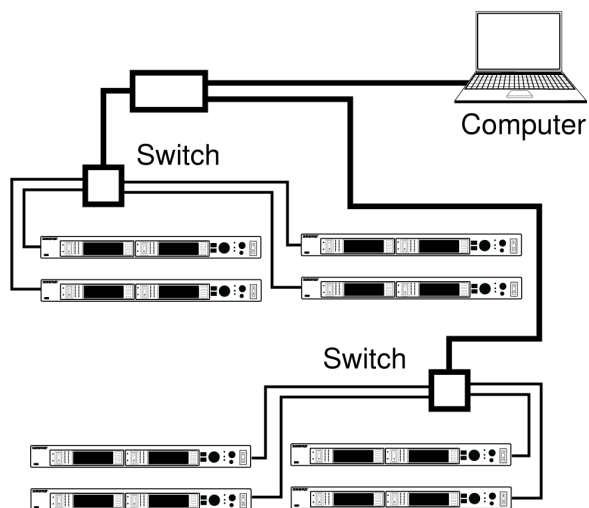

Extended Network



Direct Connection to Computer

Specifications

System Specifications

RF Carrier Frequency Range

470 to 1260 MHz, varies by region (see frequency tables)

Working Range

100 m (330 ft)

Note: Actual range depends on RF signal absorption, reflection and interference.

RF Tuning Step Size

25 kHz (typical)

Sensitivity

Analog FM	-94 dBm (typical) at 27 dB SINAD
Digital	-93 dBm (typical) at 10e-5 BER

Latency (Analog Input)

Analog FM	1.29 ms
Digital	≤2.8 ms

Audio Frequency Response

20 Hz – 15 kHz (±1 dB)

Signal-to-Noise Ratio

Digital	110 dB (typical)
----------------	------------------

Total Harmonic Distortion

Analog FM	< 0.5% (typical)Ref. at ±34 kHz deviation @1 kHz	Ref. at ±34 kHz deviation @1 kHz
Digital	< 0.01% (typical)Ref. at ±18 dBv, 1 kHz, digital gain @ 0 dB	Ref. at ±18 dBv, 1 kHz, digital gain @ 0 dB

MPX Pilot Tone (Analog FM)

19 kHz

System Audio Polarity

Not inverted

ADXR Wireless Bodypack Receiver

Dimensions

102 mm × 68 mm × 21.5 mm (4.0 in. x 2.7 in. x 0.85 in.) H x W x D

Weight

124 g (4.4 oz.), without battery

Housing

Aluminum 6061-T6, PC/ABS

Battery Type

Shure SB910 Rechargeable Li-Ion, or ×3 AAA batteries via SB913A battery sled

Operating Temperature Range

-18°C (0°F) to 50°C (122°F)

Note: Battery characteristics may limit this range.

Storage Temperature Range

-29°C (-20°F) to 74°C (165°F)

Note: Battery characteristics may limit this range.

Battery Runtime

Up to 5.25 hours in True Digital Diversity

Audio

Connector

Locking 3.5mm (1/8") TRS

Minimum Load Impedance

2 Ω

Output Impedance

<1 Ω

Audio Output Power

100 mW @ 32 Ω

L/R Stereo Separation

300 Ω	>75 dB
600 Ω	>90 dB
1 kΩ	>100 dB

Dynamic Range

110 dB, A-weighted

RF Input

Antenna Type

1/4 wave

Varies by hardware variant

Connector Type

SMA

Impedance

50 Ω

Spurious Rejection

>80 dB (typical)

Image Rejection

>80 dB

Squelch Threshold

22 dB SINAD (± 3 dB) in Analog FM mode

ShowLink

Network Type

IEEE 802.15.4

Antenna Type

Zigbee Dual Conformal

Frequency Range

2.40 to 2.4835 GHz (16 channels)

RF Output Power

10 dBm (ERP)

varies by region

Receiver Frequency Bands

ADXR	Band	Frequency Range (MHz)
A (470 to 636 MHz)	G53	470 to 510
	G54	479 to 565
	G55	470 to 636*
	G56/G56J/G56K	470 to 636
	G57	470 to 608
	G63	487 to 636
	H54	520 to 636
B (606 to 810 MHz)	K54	606 to 663**
	K55	606 to 694
	K56	606 to 714
	K58	622 to 698
	K60	614 to 703
	L60	630 to 698
C (925 to 960 MHz)	X51	925 to 937.5
	X55	941 to 960
P55 (694 to 806 MHz)	P55	694 to 703, 748 to 758, 803 to 806
X57 (961 to 1154 MHz)	X57	961 to 1154

ADXR	Band	Frequency Range (MHz)
Z16† (1240 to 1260 MHz)	Z16	1240 to 1260

*With a gap between 608 to 614 MHz.

**With a gap between 608 to 614 MHz and a gap between 616 to 653 MHz.

†Z16 for Japan only

K55 606-694 MHz



Country Code	Frequency Range
Code de Pays	Gamme de frequences
Codice di paese	Gamme di frequenza
Código de país	Gama de frecuencias
Länder-Kürzel	Frequenzbereich
A, B, BG, CH, CY, CZ, D, DK, EST, F	*
FIN, GB, GR, H, HR, I, IRL, IS, L, LT	*
M, N, NL, P, PL, RO, S, SK, SLO, TR	*
all other countries	*

* This equipment may be capable of operating on some frequencies not authorized in your region. See [Licensing Information](#).

G56 470-636 MHz



Country Code	Frequency Range
Code de Pays	Gamme de frequences
Codice di paese	Gamme di frequenza
Código de país	Gama de frecuencias
Länder-Kürzel	Frequenzbereich
A, B, BG, CH, CY, CZ, D, DK, EST, F	*
FIN, GB, GR, H, HR, I, IRL, IS, L, LT	*
M, N, NL, P, PL, RO, S, SK, SLO, TR	*
all other countries	*

* This equipment may be capable of operating on some frequencies not authorized in your region. See [Licensing Information](#).

K57 606-790 MHz

Country Code	Frequency Range
Code de Pays	Gamme de frequences
Codice di paese	Gamme di frequenza
Código de país	Gama de frecuencias
Länder-Kürzel	Frequenzbereich
A, B, BG, CH, CY, CZ, D, DK, EST, F	*
FIN, GB, GR, H, HR, I, IRL, IS, L, LT	*
M, N, NL, P, PL, RO, S, SK, SLO, TR	*
all other countries	*

* This equipment may be capable of operating on some frequencies not authorized in your region. See [Licensing Information](#).

No user-operated control of power, frequency, or other parameters are available beyond those specified in this operating manual.

Please follow your regional recycling scheme for batteries, packaging, and electronic waste.

ADTQ (Quad) and ADTD (Dual) Transmitters

Dimensions

44 mm × 482 mm × 385 mm (1.7" × 19.0" × 15.2") H × W × D

Weight

ADTQ	4.7 kg (10.4 lb)
ADTQDC	5.0 kg (11.1 lb)
ADTD	4.7 kg (10.1 lb)
ADTDDC	4.9 kg (10.8 lb)

Housing

Steel; Extruded aluminum

AC Power Requirements

AC Input	100 to 240 V AC, 50-60 Hz, 1.2 A max (6.2 A max outlet loaded)
AC Output	100-240 V AC, 5A max, 50/60 Hz UNSW
DC Input*	12-48 V DC, 10.1 A max

* ADTQDC and ADTDDC only

RF Connector Type

BNC

RF Output Impedance50 Ω **Network Interface**

10/100 Mbps, 1Gbps, Dante Digital Audio

Fuse

T5A

Operating Temperature Range

-18°C (0°F) to 50°C (122°F)

Storage Temperature Range

-29°C (-20°F) to 74°C (165°F)

Audio Input**Polarity**

Positive

Nominal Input Level

Switchable +4 dB u, -10 dBV

Maximum Input Level

+4 dBV	28 dBV
-10 dBV	16 dBV

Connector Types and Pin Assignments

Analog XLR	1 = ground, 2 = hot, 3 = cold
6.35mm (¼") TRS	Tip = hot, Ring = cold, Sleeve = ground)
AES3 XLR	1 = ground, 2 = hot, 3 = cold dig audio

Impedance32.59 K Ω **Gain Adjustment Range**

Analog	12 dB analog (auxiliary mode)
Digital	-16 to +20 dB

Phantom Power Protection

Analog	50 V DC
AES3	100 V DC

AES3

48, 96 and 192 KHz sample rates

Dante Digital Audio

Min. Latency	250 μ s
Supported Sample Rates	48K, 96K
Bit Depth	24bit

Audio Output (Headphone)

Connector Type

Locking 3.5mm ($\frac{1}{8}$ ") TRS

Minimum Load Impedance

2 Ω

Output Impedance

<1 Ω

Audio Output Power

100 mW @ 32 Ω

L/R Stereo Separation

300 Ω	>75 dB
600 Ω	>90 dB
1 kΩ	>100 dB

Dynamic Range

110 dB, A-weighted

Transmitter Frequency Bands

Band	Frequency Range (MHz)
G53	470 to 510
G54	479 to 565
G55†	470 to 636*
G56/G56J/G56K	470 to 636
G57	470 to 608
G63	487 to 636
H54	520 to 636
K54	606 to 663**
K55	606 to 694

Band	Frequency Range (MHz)
K56	606 to 714
K58	622 to 698
K60	614 to 703
L60	630 to 698
P55	694 to 703, 748 to 758, 803 to 806
X51	925 to 937.5
X55	941 to 960
X57	961 to 1154
Z16††	1240 to 1260

*With a gap between 608 to 614 MHz.

**With a gap between 608 to 614 MHz and a gap between 616 to 653 MHz.

†Operation mode varies according to region. In Brazil, High Density mode is used. The maximum power level for Peru is 10mW.

††Z16 for Japan only

K55 606-694 MHz



Country Code	Frequency Range
Code de Pays	Gamme de frequences
Codice di paese	Gamme di frequenza
Código de país	Gama de frecuencias
Länder-Kürzel	Frequenzbereich
A, B, BG, CH, CY, CZ, D, DK, EST, F	*
FIN, GB, GR, H, HR, I, IRL, IS, L, LT	*
M, N, NL, P, PL, RO, S, SK, SLO, TR	*
all other countries	*

* This equipment may be capable of operating on some frequencies not authorized in your region. See [Licensing Information](#).

G56 470-636 MHz



Country Code	Frequency Range
Code de Pays	Gamme de frequences
Codice di paese	Gamme di frequenza
Código de país	Gama de frecuencias
Länder-Kürzel	Frequenzbereich
A, B, BG, CH, CY, CZ, D, DK, EST, F	*
FIN, GB, GR, H, HR, I, IRL, IS, L, LT	*
M, N, NL, P, PL, RO, S, SK, SLO, TR	*
all other countries	*

* This equipment may be capable of operating on some frequencies not authorized in your region. See [Licensing Information](#).

K57 606-790 MHz

Country Code	Frequency Range
Code de Pays	Gamme de frequences
Codice di paese	Gamme di frequenza
Código de país	Gama de frecuencias
Länder-Kürzel	Frequenzbereich
A, B, BG, CH, CY, CZ, D, DK, EST, F	*
FIN, GB, GR, H, HR, I, IRL, IS, L, LT	*
M, N, NL, P, PL, RO, S, SK, SLO, TR	*
all other countries	*

* This equipment may be capable of operating on some frequencies not authorized in your region. See [Licensing Information](#).

No user-operated control of power, frequency, or other parameters are available beyond those specified in this operating manual.

Please follow your regional recycling scheme for batteries, packaging, and electronic waste.

AD8C Antenna Combiner

Dimensions

44 mm × 482 mm × 385 mm (1.7" × 19.0" × 15.2") H × W × D

Weight

AD8C	3.8 kg (8.3 lb)
AD8CDC	3.9 kg (8.7 lb)

Housing

Low Carbon Steel (Chassis); Aluminum (Front panel & cover)

Power Requirements

AC Input	100 to 240 V AC, 50-60 Hz, 0.68 A max (5.68 A max outlet loaded)
AC Output	100 to 240 V AC, 5A max, 50/60 Hz UNSW
DC Output*	10.9-14.8 V DC, 3.3 A max

* AD8CDC only

Fuse

T5A

Operating Temperature Range

-18°C (0°F) to 63°C (145.4°F)

Storage Temperature Range

-29°C (-20°F) to 74°C (165°F)

Network Interface

10/100 Mbps, 1Gbps, Dante Digital Audio

Frequency Range

AD8C	470 - 960 MHz
AD8CX	960 - 1260 MHz

RF Connector Type

Input	BNC (×8)
Output	BNC (×3)

RF Input/Output Configuration

Passive

Impedance

50 Ω

Insertion Loss

4:1	-8 dB (typical)
8:1	-12 dB (typical)

RF Port to Port Isolation

>20 dB (25 dB typical)

RF Input

Peak	36 dBm (4W)
-------------	-------------

Average	27 dBm (0.5W)
----------------	---------------

AD221 Antenna Combiner

Dimensions

34 mm × 101.4 mm × 92 mm (1.3" × 4.0" × 3.6") H × W × D

Weight

251 g (0.55 lb)

Housing

Cast aluminum

Operating Temperature Range

-18°C (0°F) to 63°C (145.4°F)

Storage Temperature Range

-29°C (-20°F) to 74°C (165°F)

Connector Type

BNC (×3)

Frequency Range

AD221	470 - 960 MHz
AD221X	960 - 1260 MHz

Impedance

50 Ω

RF Input/Output Configuration

Passive

Insertion Loss

4 dB (typical)

RF Port to Port Isolation

> 20 dB (25 dB typical)

25 dB typical

RF Input

Peak	36 dBm (4W)
Average	27 dBm (0.5 W)

SBC441 4-Bay Networked Charger

Dimensions

60.3 mm × 78.8 mm × 216.5 mm (2.4" × 3.1" × 8.5") H × W × D

Weight

531 g (1.17 lb)

Housing

Molded PC/ABS plastic, cast aluminum

Operating Temperature Range

-18°C (0°F) to 50°C (122°F)

Note: Battery characteristics may limit this range.

Storage Temperature Range

-29°C (-20°F) to 74°C (165°F)

Compatible Devices

Batteries	Up to 4 SB910
Receivers	Up to 4 ADXR

Network Interface

10/100 Mbps Ethernet (2x)

Network Addressing Capability

DHCP or manual IP address

Charge Time

3 hours

Charge Current

1.25 A (maximum)

External Power Supply

PS60

Power Requirement (input rating)

15 V, 4.0 A (maximum)

Important Product Regulatory Information

EMC conformance testing is based on the use of supplied and recommended cable types. The use of other cable types may degrade EMC performance.

Introduction to EMC

Electromagnetic Interference (EMI) is any signal or emission, radiated in free space or conducted along power or signal leads, that endangers the functioning of radio navigation or other safety service or seriously degrades, obstructs, or repeatedly interrupts a licensed radio communications service. Radio communications services include but are not limited to AM/FM commercial broadcast, television, cellular services, radar, air-traffic control, pager, and Personal Communication Services (PCS). These licensed radio services, and unlicensed radio services, such as WLAN, ZIGBEE or Bluetooth, along with unintentional radiators such as digital devices contribute to the electromagnetic environment.

Electromagnetic Compatibility (EMC) is the ability of items of electronic equipment to function properly together in the electronic environment. While this equipment has been designed and determined to be compliant with regulatory agency limits for EMI, there is no guarantee that interference will not occur in a particular installation.

Shure products are designed, tested, and classified for their intended electromagnetic environment. These electromagnetic environment classifications generally refer to the following harmonized definitions:

- Class B products are intended for use in residential/domestic environments but may also be used in non-residential/non-domestic environments.

Note: The residential/domestic environment is an environment where the use of broadcast radio and television receivers may be expected within a distance of 10 m from where this product is used.

- Class A products are intended for use in non-residential/non-domestic environments. Class A products may also be utilized in residential/domestic environments but may cause interference and require the user to take adequate corrective measures.

Regulatory Information for Class B EMC Products

CE Notice

Hereby, Shure Incorporated declares that this product with CE Marking has been determined to be in compliance with European Union requirements.

The full text of the EU declaration of conformity is available at the following site: <https://www.shure.com/en-EU/support/declarations-of-conformity>.

UKCA Notice

Hereby, Shure Incorporated declares that this product with UKCA Marking has been determined to be in compliance with UKCA requirements.

The full text of the UK declaration of conformity is available at the following site: <https://www.shure.com/en-GB/support/declarations-of-conformity>.

UK Cybersecurity

UK SI 2023 NO. 1007 STATEMENT OF COMPLIANCE

Product Type: Relevant connectable products as defined by The Product Security and Telecommunications Infrastructure (Security Requirements for Relevant Connectable Products) Regulations 2023.

Manufacturer Statement: We, Shure Incorporated, certify and declare as manufacturer under our sole responsibility, that the above mentioned product(s) conform(s) to Schedule 2 of the essential requirements of the listed applicable United Kingdom Statutory Instruments (including their amendments) and the associated norms.

Information on how to report security issues: The latest version of Shure's Disclosure policy can be found at the following link: <https://www.shure.com/en-GB/about-us/security>

Security update periods: Shure provides support regarding hardware and software updates that continue the integral cyber security safety of Shure products up to 24 months after end of life (AEOL). For the full statement regarding Shure's product support policy, and information regarding products end of life status information can be found at the following link: <https://www.shure.com/en-GB/about-us/security>

Manufacturer:

Shure Incorporated 5800 Touhy Avenue
Niles, Illinois, 60714-4608 U.S.A.
Website: www.Shure.com.

Technical documentation is kept at:

Shure Incorporated, Corporate Global Compliance Engineering Division

UK Importer/Representative:

Shure UK Limited
Unit 2, The IO Centre, Lea Road, Waltham Abbey, Essex, EN9 1AS, U.K.
Phone: +44 (0)1992 - 703058
Email: EMEAsupport@shure.de

On behalf of Manufacturer:

Chad Ayers

01 February 2024 Niles, Illinois

Senior Director, Global Compliance

FCC Notice

This equipment has been tested and found to comply with the limits for a Class B digital device pursuant to Part 15 of the FCC Rules. These limits are designed to provide reasonable protection against harmful interference when the equipment is operated in a residential installation. This equipment generates, uses, and can radiate radio frequency energy and, if not installed and used in accordance with the instructions, may cause harmful interference with radio communications. However, there is no guarantee that interference will not occur in a particular installation. If this equipment does cause harmful interference with radio or television reception, which can be determined by turning the equipment off and on, you are encouraged to try to correct the interference by one or more of the following measures:

- Reorient or relocate the antenna of the radio/television receiver.
- Increase the separation between this equipment and the radio/television receiver.
- Plug the equipment into a different outlet so that the equipment and the radio/television receiver are on different power mains branch circuits.
- Consult a representative of Shure or an experienced radio/television technician for additional suggestions.

This device complies with Part 15 of the FCC Rules. Operation is subject to the following two conditions:

1. This device may not cause harmful interference.
2. This device must accept any interference received, including interference that may cause undesired operation.

Notice: The FCC regulations provide that changes or modifications not expressly approved by Shure Incorporated could void your authority to operate this equipment.

For information regarding responsible party and other matters relating to FCC compliance, please contact Shure Incorporated, 5800 W. Touhy Avenue, Niles, Illinois 60714-4608 U.S.A. shure.com/contact

Canada, ISED Notice

Notice: The Industry Canada regulations provide that changes or modifications not expressly approved by Shure Inc. could void your authority to operate this equipment.

This Class B digital apparatus complies with Canadian ICES-003. Cet appareil numérique de la classe B est conforme à la norme NMB-003 du Canada.

Regulatory Information for Wireless Products

This equipment complies with FCC radiation exposure limits set forth for an uncontrolled environment. End user must follow the specific operating instructions for satisfying RF exposure compliance. This transmitter must not be co-located or operating in conjunction with any other antenna or transmitter.

This equipment complies with FCC radiation exposure limits set forth for an uncontrolled environment. This equipment should be installed and operated with minimum distance 20 cm between the radiator & your body.

Industry Canada (IC) Notices

This device contains licence-exempt transmitter(s)/receiver(s) that comply with Innovation, Science and Economic Development Canada's licence-exempt RSS(s). Operation is subject to the following two conditions:

1. This device may not cause interference.
2. This device must accept any interference, including interference that may cause undesired operation of the device.

L'émetteur/récepteur exempt de licence contenu dans le présent appareil est conforme aux CNR d'Innovation, Sciences et Développement économique Canada applicables aux appareils radio exempts de licence. L'exploitation est autorisée aux deux conditions suivantes :

1. L'appareil ne doit pas produire de brouillage;
2. L'appareil doit accepter tout brouillage radioélectrique subi, même si le brouillage est susceptible d'en compromettre le fonctionnement.

This equipment complies with ISED radiation exposure limits set forth for an uncontrolled environment. End user must follow the specific operating instructions for satisfying RF exposure compliance. This transmitter must not be co-located or operating in conjunction with any other antenna or transmitter.

Cet équipement est conforme aux limites d'exposition aux rayonnements ISED établies pour un environnement non contrôlé. L'utilisateur final doit suivre les instructions spécifiques pour satisfaire les normes. Cet émetteur ne doit pas être co-implanté ou fonctionner en conjonction avec toute autre antenne ou transmetteur.

This equipment complies with ISED radiation exposure limits set forth for an uncontrolled environment. End user must follow the specific operating instructions for satisfying RF exposure compliance. This transmitter must not be co-located or operating in conjunction with any other antenna or transmitter. The antenna(s) must be installed such that a minimum separation distance of 20 cm is maintained between the radiator (antenna) and all persons at all times.

Cet équipement est conforme aux limites d'exposition aux rayonnements ISED établies pour un environnement non contrôlé. L'utilisateur final doit suivre les instructions spécifiques pour satisfaire les normes. Cet émetteur ne doit pas être co-implanté ou fonctionner en conjonction avec toute autre antenne ou transmetteur. La ou les antennes doivent être installées de telle façon qu'une distance de séparation minimum de 20 cm soit maintenue entre le radiateur (antenne) et toute personne à tout moment.

Additional Canadian information on RF exposure also can be found at the following Web address: <http://www.ic.gc.ca/eic/site/smt-gst.nsf/eng/sf08792.html>

ANATEL Notice

Este equipamento não tem direito à proteção contra interferência prejudicial e não pode causar interferência em sistemas devidamente autorizados. Para maiores informações, consulte o site da ANATEL – <http://www.anatel.gov.br>.

IFETEL Notice

La operación de este equipo está sujeta a las siguientes dos condiciones: (1) es posible que este equipo o dispositivo no cause interferencia perjudicial y (2) este equipo o dispositivo debe aceptar cualquier interferencia, incluyendo la que pueda causar su operación no deseada.

KCC Notice

해당 무선설비는 전파혼신 가능성이 있으므로 인명안전과 관련된 서비스는 할 수 없음

NBTC Notice

เครื่องโทรคมนาคมและอุปกรณ์นี้มีความสอดคล้องตามมาตรฐานหรือข้อกำหนดทางเทคนิคของ กสทช.

NCC Notice

Connection and use of this communications equipment is permitted by the Nigerian Communications Commission.

NCC Notice

低功率射頻器材技術規範

取得審驗證明之低功率射頻器材，非經核准，公司、商號或使用者均不得擅自變更頻率、加大功率或變更原設計之特性及功能。低功率射頻器材之使用不得影響飛航安全及干擾合法通信；經發現有干擾現象時，應立即停用，並改善至無干擾時方得繼續使用。前述合法通信，指依電信管理法規定作業之無線電通信。低功率射頻器材須忍受合法通信或工業、科學及醫療用電波輻射性電機設備之干擾。

本器材須經專業工程人員安裝及設定，始得使用，且不得使用非型式認證證明所列天線或直接販售給一般消費者。

614MHz-703MHz: 使用頻段供其他通訊業務使用時，器材應即停止使用

SRRC Notice

- (一) 本产品符合“微功率短距离无线电发射设备目录和技术要求”的具体条款和使用场景；
- (二) 不得擅自改变使用场景或使用条件、扩大发射频率范围、加大发射功率（包括额外加装射频功率放大器），不得擅自更改发射天线；
- (三) 不得对其他合法的无线电台（站）产生有害干扰，也不得提出免受有害干扰保护；
- (四) 应当承受辐射射频能量的工业、科学及医疗（ISM）应用设备的干扰或其他合法的无线电台（站）干扰；
- (五) 如对其他合法的无线电台（站）产生有害干扰时，应立即停止使用，并采取措施消除干扰后方可继续使用；
- (六) 在航空器内和依据法律法规、国家有关规定、标准划设的射电天文台、气象雷达站、卫星地球站（含测控、测距、接收、导航站）等军民用无线电台（站）、机场等的电磁环境保护区域内使用微功率设备，应当遵守电磁环境保护及相关行业主管部门的规定。

Regulatory Information for Wireless Products Utilizing TV Frequency Bands

EU/UK Non-Harmonized Frequency Information



Country Code	Frequency Range
Code de Pays	Gamme de frequences
Codice di paese	Gamme di frequenza
Código de país	Gama de frecuencias
Länder-Kürzel	Frequenzbereich
A, B, BG, CH, CY, CZ, D, EST, F, GB, GR, H, I, IS, L, LT, NL, P, PL, S, SK, SLO, DK, FIN, M, N, HR, E, IRL, LV, RO, TR	xxx - xxx MHz*
UK	xxx - xxx MHz*
all other countries	*

* This equipment may be capable of operating on some frequencies not authorized in your region. See [Licensing Information](#).

Canada Warning for Wireless

This device operates on a no-protection, no-interference basis. Should the user seek to obtain protection from other radio services operating in the same TV bands, a radio licence is required. For further details, consult Innovation, Science and Economic Development Canada's document Client Procedures Circular CPC-2-1-28, Voluntary Licensing of Licence-Exempt Low-Power Radio Apparatus in the TV Bands.

Ce dispositif fonctionne selon un régime de non-brouillage et de non-protection. Si l'utilisateur devait chercher à obtenir une certaine protection contre d'autres services radio fonctionnant dans les mêmes bandes de télévision, une licence radio serait requise. Pour en savoir plus, veuillez consulter la Circulaire des procédures concernant les clients CPC-2.1.28, Délivrance de licences sur une base volontaire pour les appareils radio de faible puissance exempts de licence et exploités dans les bandes de télévision d'Innovation, Sciences et Développement économique Canada.

ACMA Notice

WARNING: This device operates under an ACMA class license and must comply with all conditions of that license including operating frequencies.

Regulatory Information for Wireless ZIGBEE Devices

MIC Notice

運用に際しての注意

この機器の使用周波数帯では、電子レンジ等の産業・科学・医療用機器のほか工場の製造ライン等で使用されている移動体識別用の構内無線局（免許を要する無線局）及び特定小電力無線局（免許を要しない無線局）並びにアマチュア無線局（免許を要する無線局）が運用されています。

1. この機器を使用する前に、近くで移動体識別用の構内無線局及び特定小電力無線局並びにアマチュア無線局が運用されていないことを確認して下さい。
2. 万一、この機器から移動体識別用の構内無線局に対して有害な電波干渉の事例が発生した場合には、速やかに使用周波数を変更するか又は電波の発射を停止した上、下記連絡先にご連絡頂き、混信回避のための処置等（例えば、パーティションの設置など）についてご相談して下さい。
3. その他、この機器から移動体識別用の特定小電力無線局あるいはアマチュア無線局に対して有害な電波干渉の事例が発生した場合など何かお困りのことが起きたときは、保証書に記載の販売代理店または購入店へお問い合わせください。代理店および販売店情報は Shure 日本語ウェブサイト <http://www.shure.co.jp> でもご覧いただけます。

現品表示記号について

2.4 DS4

現品表示記号は、以下のことを表しています。この無線機器は 2.4GHz 帯の電波を使用し、変調方式は「DS」方式、想定干渉距離は 40m です。2,400MHz ~ 2,483.5MHz の全帯域を使用し、移動体識別装置の帯域を回避することはできません。

Environmental Regulatory Information

Waste Electrical and Electronic Equipment (WEEE) Directive



In the European Union and the United Kingdom, this label indicates that this product should not be disposed of with household waste. It should be deposited at an appropriate facility to enable recovery and recycling.

Registration, Evaluation, Authorization of Chemicals (REACH) Directive

REACH (Registration, Evaluation, Authorization of Chemicals) is the European Union (EU) and the United Kingdom (UK) chemical substances regulatory framework. Information on substances of very high concern contained in Shure products in a concentration above 0.1% weight over weight (w/w) is available upon request.

Recycling Information

Please consider the environment, electric products and packaging are part of regional recycling schemes and do not belong to regular household waste.

中国 RoHS

部件名称	有害物质										
	Pb	Cd	Hg	Cr(VI)	PBB	PBDE	DBP	BBP	DIBP	DEHP	
电路模块	X	○	○	○	○	○	○	○	○	○	
金属模块	X	○	○	○	○	○	○	○	○	○	
线缆及其组件	X	○	○	○	○	○	○	○	○	○	
电源适配器*	X	○	○	○	○	○	○	○	○	○	
锂电池组*	X	○	○	○	○	○	○	○	○	○	

本表格依据 SJ/T11364 的规定编制。

O: 表示该有害物质在该部件所有均质材料中的含量均在 GB/T26572 规定的限量要求以下。

X: 表示该有害物质至少在该部件某一均质材料中的含量超出 GB/T26572 规定的限量要求。

注 1: 本产品大部分的部件采用无害的环保材料制造, 含有有害物质的部件皆因全球技术发展水平的限制而无法实现有害物质的替代。

注 2: 以上未列出的部分, 表明其有害物质含量均满足电器电子产品有害物质限制使用国家标准要求

*: 表示如果包含部分

部件名称	电池有害物质					
	铅	汞	镉	六价铬	多溴联苯	多溴二苯醚
线路板	○	○	○	○	○	○
线路板上电阻中陶瓷	x	○	○	○	○	○
线路板上电子元件	○	○	○	○	○	○
塑料外壳	○	○	○	○	○	○

本表格依据 SJ/T11364 的规定编制。

O: 表示该有害物质在该部件所有均质材料中的含量均在 GB/T26572 规定的限量要求以下。

X: 表示该有害物质至少在该部件某一均质材料中的含量超出 GB/T26572 规定的限量要求。

注: 本产品大部分的部件采用无害的环保材料制造, 含有有害物质的部件皆因全球技术发展水平的限制而无法实现有害物质的替代。

臺灣 RoHS

Notice: Taiwan RoHS tables are provided by GC on a per-product basis.

Battery Regulatory Information

CE Notice

Hereby, Shure Incorporated declares that this product with CE Marking has been determined to be in compliance with European Union requirements.

The full text of the EU declaration of conformity is available at the following site: <https://www.shure.com/en-EU/support/declarations-of-conformity>.

UKCA Notice

Hereby, Shure Incorporated declares that this product with UKCA Marking has been determined to be in compliance with UK-CA requirements.

The full text of the UK declaration of conformity is available at the following site: <https://www.shure.com/en-GB/support/declarations-of-conformity>.

EU and UK Battery Directive



In the European Union and the United Kingdom, this label indicates that the batteries in this product should be collected separately and not be disposed of with household waste. Substances in batteries can have a potential negative impact on health and environment and you have a role in recycling waste batteries thus contributing to the protection, preservation, and im-

provement of the quality of the environment. You should contact your local authority or retailer for details of the collection and recycling schemes available.

Note: There is no mercury content in the product.

Certifications

FCC / IC ID

FCC IDs: DD4ADTQG57, DD4ADTQK54, DD4ADTQX55, DD4ADTDG57, DD4ADTDK54, DD4ADTDX55

IC IDs: 616A-ADTQG57, 616A-ADTDG57

Certification and Compliance Markings

