

CVAS PROGless

EBISS-IFBOX

INSTRUCTION MANUAL



■ TABLE OF CONTENTS

■	TABLE OF CONTENTS	2
■	IMPORTANT SAFEGUARDS	3
	Usage Precautions	6
	Product Features	8
①	Before Use	9
	◆ Package contents	9
	◆ Part names	10
②	Preparation and Connection	12
	◆ Power on	12
	◆ Connecting IFBOX and TPC07	13
	Fixing the IFBOX to a desk	14
	Using the rubber foot	14
	◆ Connecting to a network	15
③	Using the IFBOX	16
	◆ What you can do with the IFBOX	16
	◆ Configuration of the settings via a browser	17
	◆ TCP/IP specifications	22
	■ Using the IFBOX with TCP/IP	23
	■ Command format	23
	■ Response command format	25
	■ Sending a command to a serial device	26
	■ Contact output port control	28
	■ Contact input port control	31
	■ Switching the contact type of the Contact input ports	33
	■ Serial port status settings	34
	■ Remote control learning	36
	■ Commands for remote control learning	38
	■ Example of how to perform remote control learning	42
	■ Using learned remote control command	44
	■ Remote control command transmission commands	44
	■ Example of how to start/stop remote control command transmission	45
④	Troubleshooting	46
⑤	Specifications	47
	Interface specifications	47
	Main unit specifications	50
■	Trademarks and Licenses	51



■ IMPORTANT SAFEGUARDS

Please read all precautions and warnings before starting to use the product.







The information is provided to ensure proper operation of this product and will prevent you or others from personal injury or loss of assets.

Review the following symbols so that you understand them before reading the rest of the manual.

















Please read carefully and keep the manual in a safe place for future reference.

	Warning	Ignoring this indication and operating the system incorrectly subjects the user to possible risk of injury or death.
	Caution	Ignoring this indication and operating the system incorrectly subjects the user to risk of injury or loss of assets.

Meaning of Symbols

	Name: Caution Meaning: Indicates that the user must, without fail, pay careful attention to any sentences or illustrations marked with a Caution symbol.
	Name: Prohibited Meaning: Indicates that the user must pay careful attention to any sentences or illustrations marked with a Prohibited (do not do) symbol.
	Name: Do not use in a bathroom or shower cubicle Meaning: Indicates that using the product in a bathroom or shower cubicle could result in injuries through a fire or electric shock, and is strictly prohibited.
	Name: Do not touch Meaning: Indicates that touching the area could result in injuries through electric shock, and is strictly prohibited.
	Meaning: Do not disassemble Meaning: Indicates that disassembling the product could result in injuries through electric shock, and is strictly prohibited.
	Name: Compulsory Meaning: Indicates that the user must pay careful attention to any sentences or illustrations marked with a Compulsory (must do) symbol.
	Name: Disconnect the Power cable and the AC adapter Meaning: Indicates that the user must disconnect the Power cable.

Warning

- If for any reason smoke comes out of the product, or you notice any unusual odors or sounds, immediately disconnect the power cable and AC adapter.
-  Continuing to use the product while it is operating unusually could result in a fire or electric shock. Check that smoke is no longer coming out of the product, and then contact the dealer where you purchased the product to request maintenance.
- Do not attempt to service this product yourself.
-  If for any reason liquid is spilled into the product, immediately disconnect the power cable and AC adapter. Contact the dealer where you purchased the product immediately. Continuing to use the product in this condition could result in a fire or electric shock.
-  If for any reason foreign objects enter the product, immediately disconnect the power cable and AC adapter, and contact the dealer where you purchased the product immediately. Continuing to use the product in this condition could result in a fire or electric shock.
- (Be extra careful if there are children in the area when using the product.)
-  If for any reason the product is dropped or the cabinet is damaged, disconnect the power cable and AC adapter, and contact the dealer where you purchased the product immediately. Continuing to use the product in this condition could result in a fire or electric shock.
-  If the power cable or AC adapter is damaged (e.g. if the inside of the cable is exposed or broken), contact the dealer where you purchased the product to request a replacement. Continuing to use the product in this condition could result in a fire or electric shock.
-  Do not remove the cabinet or cover from this product. Doing so may expose you to dangerous voltage and could result in electric shock.
- Contact the dealer where you purchased the product for any internal inspections, maintenance, or repair.
-  Do not modify the product.
- This could result in a fire or electric shock.
-  Do not place this product on an uneven surface or unstable stand.
- It could fall or topple over and result in an injury.
-  Be sure to use the power cable and AC adapter supplied with the product.
- Otherwise, it could result in a fire or electric shock.
-  Do not spill water or insert any foreign objects into the product.
- This could result in a fire or electric shock.
-  Do not damage, process, pinch, twist, pull, or heat the power cable or AC adapter.
- The cable could be damaged and result in a fire or electric shock.
-  Do not place any heavy objects on the Power cable or AC adapter, or do not place this product on top of the cable. The cable could be damaged and result in a fire or electric shock.
- (If the cable is covered by a carpet, you may not notice that a heavy object has been placed on the cable.)
-  Do not use in a bathroom or shower cubicle.
- This could result in a fire or electric shock.
-  If there is dust on the prongs of the power plug or the attachment surface, disconnect the power cable, and then remove the dust.
- The drop in insulation for the power plug could result in a fire.
-  Do not touch the product, cables, power cable, or AC adapter during a thunder storm. This could result in an electric shock.
-  Do not place vases, flowerpots, cups, cosmetics, or other containers of chemicals or water or small metal objects on top of the product.
- If liquid spills or foreign matter gets inside, it may cause a fire or electric shock.

Caution



Whenever moving the product, disconnect the power cable and the AC adapter. Then move after confirming that all cables are disconnected. Otherwise, the cable could be damaged and result in a fire or electric shock.



For safety reasons, be sure to disconnect the power cable and the AC adapter when performing a maintenance work.

Otherwise, it could result in an electric shock.



For safety reasons, if this product is not used for a long time, be sure to disconnect the power cable and the AC adapter.

Otherwise, it could result in a fire.



Do not disconnect the power cable or AC adapter by pulling the cable. By doing so may damage the cable and could result in a fire or electric shock.

Disconnect by pulling the plug of the power cable or AC adapter.



If the product is placed on a stand with casters, make sure the caster's brakes are on. It could result in an injury if it moves and falls.



Do not place the product in a damp or dusty location.

This could result in a fire or electric shock.



Do not sit on, or place any heavy objects on, this product. Be extra careful if there are any small children in the area when using the product.

It could result in an injury if it breaks.



Do not place the power cable or AC adapter next to a heater.

The cable covering could melt and result in a fire or electric shock.



Do not connect or disconnect the power cable or AC adapter with wet hands.

Otherwise, it could result in an electric shock.



Make sure the plug is securely inserted into the socket.

If it is not inserted correctly, it may generate excess heat or dust may come into contact, which could result in a fire.

Also, touching a prong of the plug could result in an electric shock.

Do not use a loose socket.



Excess heat could be generated and result in a fire. Request a replacement socket from your dealer or electrical appliance store.



Do not use the product outdoors.

It could result in a fire or electric shock.



Do not place the product in a location where it could be exposed to smoke, steam, or water droplets such as on a kitchen counter or near a humidifier. This could result in a fire or electric shock.

Usage Precautions

- Observe the contents of this guide. Failure to follow the precautions and warnings described in this guide may cause an accident.
- Be sure to use the AC adapter and power cable supplied with the product.
- The supplied AC adapter and power cable are designed for exclusive use with this product. Do not use them with other products.
- If you have any questions about how to use this product, contact the dealer where you purchased the product.
- This product is designed to be used indoors. Do not use it outdoors.
- Do not place this product in any humid, dusty, salt bearing wind, or vibrating locations. The operating environment conditions are as follows.
Temperature: 0 to 40°C
Humidity: 30 to 85% (no condensation)
- We do not guarantee the normal operation of the network function of this product in all network environments. It may not work properly depending on your network environment.

Storage and Maintenance

- Turn the power off before performing a cleaning. Use a soft, dry cloth for cleaning. Do not use any volatile solvent such as thinner or benzene.
- When storing this product, do not leave it under direct sunlight or by heaters. It may be discolored, deformed, or damaged.
- If water is spilled on the product, wipe it off with a dry cloth immediately. Pay particular attention to the salt water.
- Do not place the product on or near electrical appliances such as TVs and refrigerators.
- Be careful not to get sand or mud on it. It may cause an irreparable failure.

Other Precautions

- If the product is used for longer than the warranty period, its performance and quality may deteriorate due to the lifetime of its parts. For parts replacement (on chargeable basis), consult the dealer from whom you purchased the product.
- Copyright
It is prohibited under copyright law to use or copy any part or the whole of this document without our prior written consent.
- The contents of this document are subject to change without notice.
The latest version of the instruction manual can be downloaded from:
<https://elmousa.com>
- Disposal of the product
Be sure to initialize the internal memory and delete all data before disposing of the product.

<Notes on data loss>

The contents recorded in the memory may be destroyed or erased due to wrong operation or defect of the product. We recommend that you backup important data onto the hard disk of your computer. Note that we are not liable for any damages or lost profits arising from loss of data caused by malfunctions, repairs by third parties not designated by us, or other reasons.

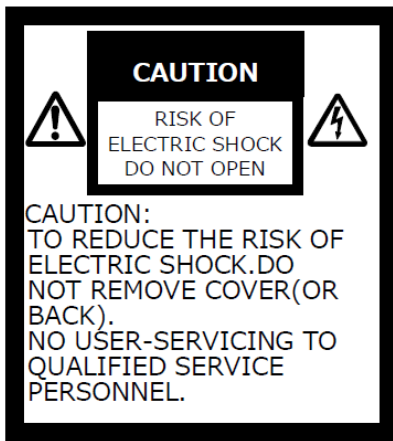

The lightning flash with arrowhead symbol, within an equilateral triangle, is intended to alert the user to the presence of uninsulated "dangerous voltage" within the product's enclosure that may be of sufficient magnitude to constitute a risk of electric shock to persons.

The exclamation point within an equilateral triangle is intended to alert the user to the presence of important operating and maintenance (servicing) instructions in the literature accompanying the product.

WARNING

TO REDUCE THE RISK OF FIRE OR ELECTRIC SHOCK, DO NOT EXPOSE THIS PRODUCT TO RAIN OR MOISTURE.

The connection of a non-shielded equipment interface cable to this equipment will invalidate the FCC Certification or Declaration of this device and may cause interference levels which exceed the limits established by the FCC for this equipment. It is the responsibility of the user to obtain and use a shielded equipment interface cable with this device. If this equipment has more than one interface connector, do not leave cables connected to unused interfaces. Changes or modifications not expressly approved by the manufacturer could void the user's authority to operate the equipment.

FOR UNITED STATES USERS: INFORMATION

This equipment has been tested and found to comply with the limits for a Class A digital device, pursuant to Part 15 of the FCC Rules. These limits are designed to provide reasonable protection against harmful interference when the equipment is operated in a commercial environment. This equipment generates, uses, and can radiate radio frequency energy and, if not installed and used in accordance with the instruction manual, may cause harmful interference to radio communications. Operation of this equipment in a residential area is likely to cause harmful interference in which case the user will be required to correct the interference at his own expense.

USER-INSTALLER CAUTION:

Your authority to operate this FCC verified equipment could be voided if you make changes or modifications not expressly approved by the party responsible for compliance to Part 15 of the FCC rules.

Disclaimer

- We are not liable for any damage caused by natural disasters such as earthquakes, lightning, fire, acts by third parties, other accidents, intentional or negligence of the customer, misuse, or use under other abnormal conditions.
- We are not liable for any incidental damage (loss of business profit, business interruption, change or loss of recorded data, etc.) resulting from the use or inability to use of this product.
- We are not liable for any damage caused by not observing the contents of this guide.
- We are not liable for any damage caused by malfunction or hang-up resulting from unintended combination with devices or software other than ours.
- We are not liable for any damage caused by repairs or modifications made by the customer or an unauthorized third party.
- Regarding this product, within the scope stipulated by law, our obligation to bear the cost shall be within the individual price of the product in any case.

Product Features

- By using a 7-inch touchscreen (EBISS-TPC07) and a compact I/F unit (EBISS-IFBOX) together, users can control or operate the connected devices with the touchscreen.

7-inch touchscreen

The body of the touchscreen is as compact as 7 inches.
It does not require a large space for installation.

Wire-saving design

Only a LAN cable is required between the touchscreen and I/F unit.
The power can be supplied from HUB (PoE compatible).

When used in combination with a switcher, it is possible to switch between devices.



Compact I/F unit

The new I/F unit is about one-fourth the size of the current product (IF-6500).
It does not require a large space for installation.

Monitors, electric screens, projectors and room lightings can be controlled collectively with EBISS-TPC07 and EBISS-IFBOX. A total AV control system can be realized in university classrooms and corporate conference rooms.

1 Before Use

◆ Package contents

The items below are included with this product. If any item is missing, visit the Elmo official website or contact the dealer from whom you have purchased this product or our branch/office near your location. <https://www.elmousa.com>

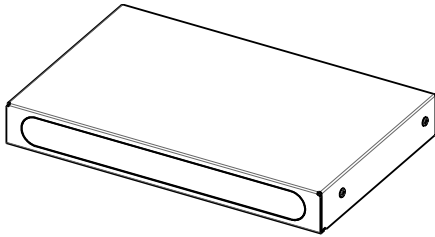

IFBOX (Main unit)

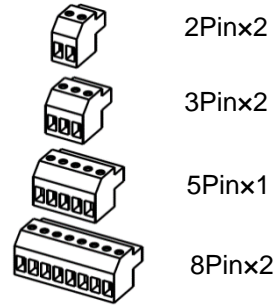

Euroblock

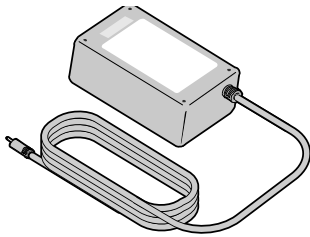

AC adapter

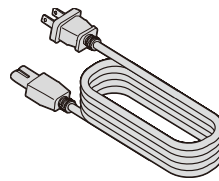

Power cable

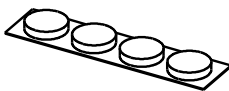

Rubber foot

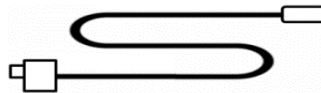

IR cable

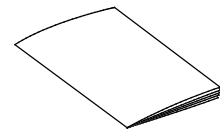

Quick Start Guide
(with Warranty Card)

◆Part names

<Front>

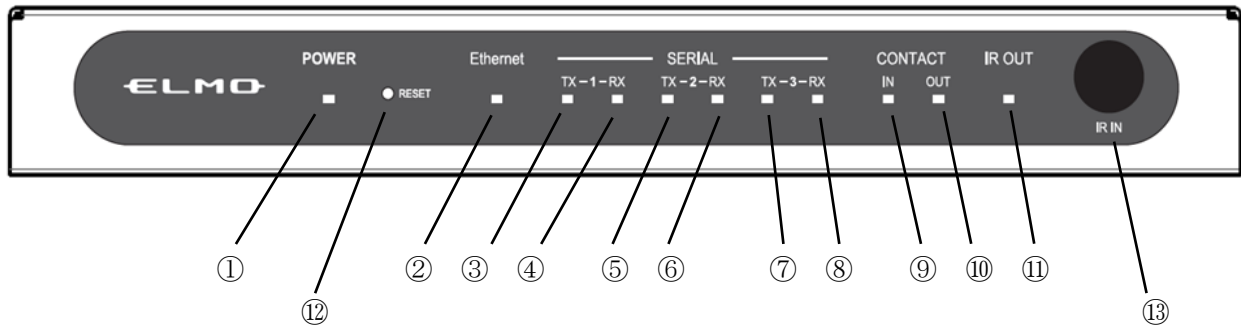

Number	Name	Description
①	Power LED	Lights up blue when AC adapter is connected.
②	Ethernet LED	Lights up blue when Ethernet connection is active.
③	SERIAL1-TX LED	Blinking green when the serial 1 signals are sent.
④	SERIAL1-RX LED	Blinking green when the serial 1 signals are received.
⑤	SERIAL2-TX LED	Blinking green when the serial 2 signals are sent.
⑥	SERIAL2-RX LED	Blinking green when the serial 2 signals are received.
⑦	SERIAL3-TX LED	Blinking green when the serial 3 signals are sent.
⑧	SERIAL3-RX LED	Blinking green when the serial 3 signals are received.
⑨	CONTACT-IN LED	Blinking green when the contact input detects the external signal.
⑩	CONTACT-OUT LED	Lights up green when the contact output is on.
⑪	IR LED	Blinking green when the IR remote control signals are emitted.
⑫	Reset switch	The IFBOX will be forcibly restarted if this switch is pressed with a fine-tipped object such as a pin.
⑬	IR receiver	Receiver of the IR remote control signals

<Rear>

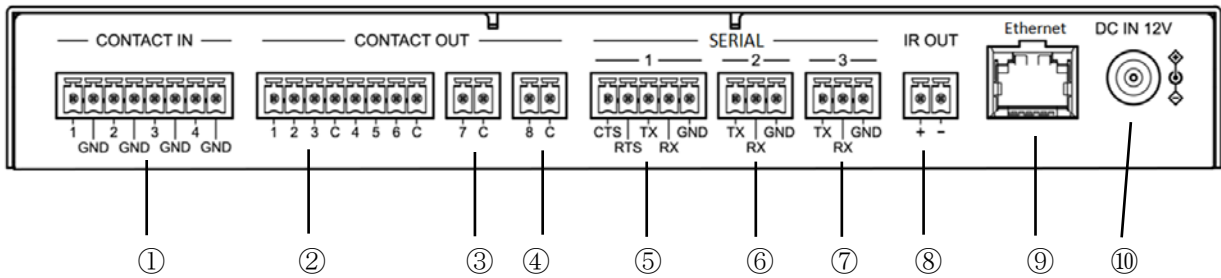

Number	Name	Description
①	Contact input port	Port for non-voltage contact input
②	Contact output port (1-6)	Port for Non-voltage relay contact output (8pin)
③	Contact output port (7)	Port for Non-voltage relay contact output (2pin)
④	Contact output port (8)	Port for Non-voltage relay contact output (2pin)
⑤	Serial port 1	Port for RS-232C communication. Flow control available
⑥	Serial port 2	Port for RS-232C communication
⑦	Serial port 3	Port for RS-232C communication
⑧	IR Output port	Port for IR signal output. Connect the supplied IR cable
⑨	Ethernet port	Port for Ethernet communication
⑩	DC IN (12V) port	Port for power supply Connect the supplied AC adapter.

For details of the port specifications, refer to P.47.

<Side>

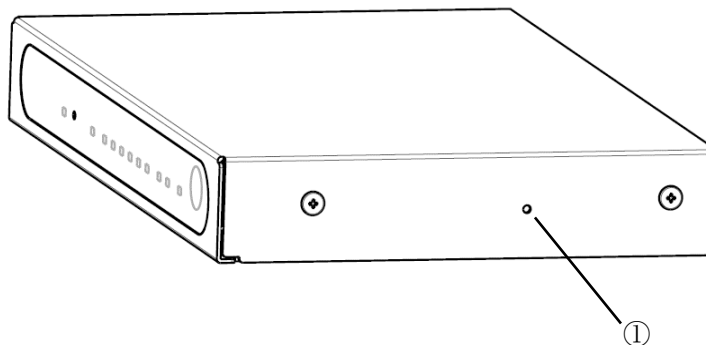

Number	Name	Description
①	Factory default reset switch	The IFBOX will be reset to factory default if this switch is pressed with a fine-tipped object such as a pin for over 3 seconds.

② Preparation and Connection

◆Power on

Connect the power cable and the AC adapter. Connect the AC adapter and the main unit. Then connect the power cable to the wall outlet.

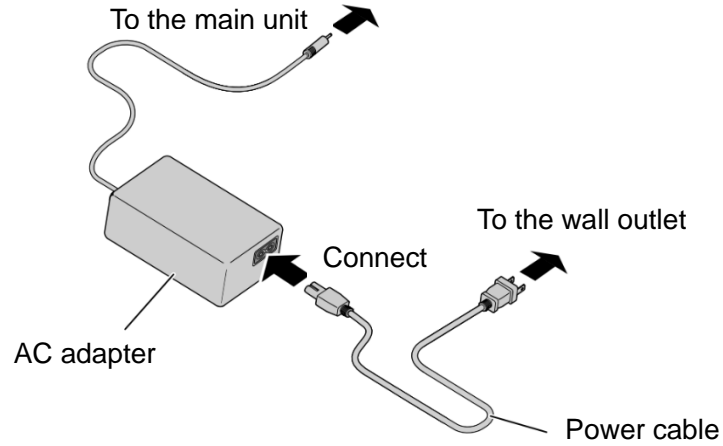

Note

- To turn off the power, disconnect the AC adapter.
- Press the Reset switch on the front of the main unit or disconnect the AC adapter to restart the IFBOX.

◆Connecting IFBOX and TPC07

Connect the IFBOX and the separately sold TPC07.

A: When connecting them directly

Connect the AC adapter to each device and connect them with LAN cable.

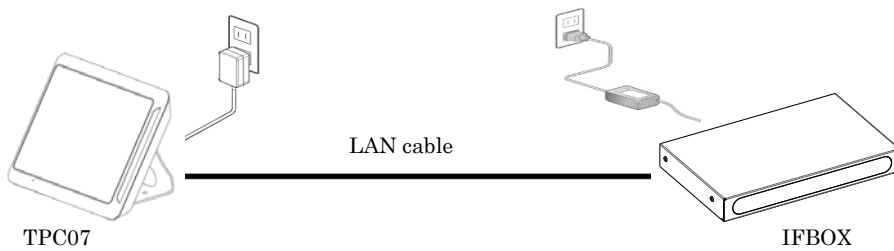

B: When using a switching hub (non-PoE)

Connect the AC adapter to each device. Then connect the IFBOX, TPC07, and a hub with LAN cable.

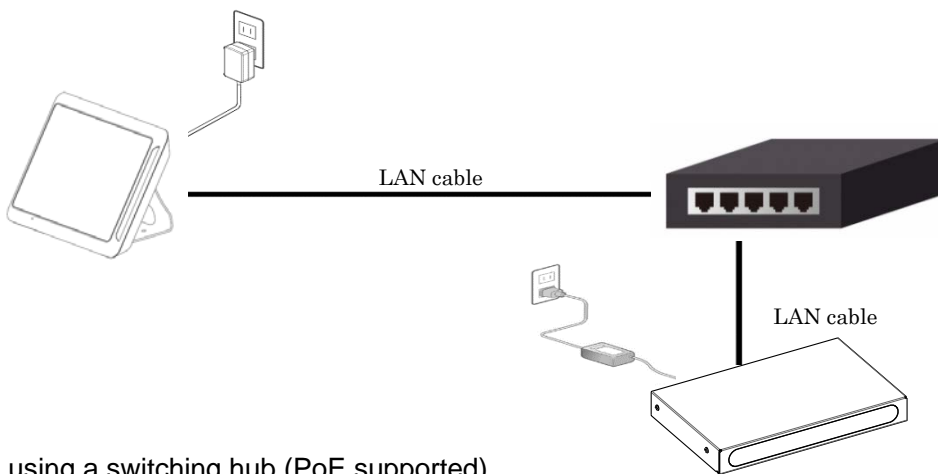

C: When using a switching hub (PoE supported)

When using a switching hub that supports PoE power supply, the AC adapter is not required for the TPC07.

For the IFBOX, the AC adapter is required.

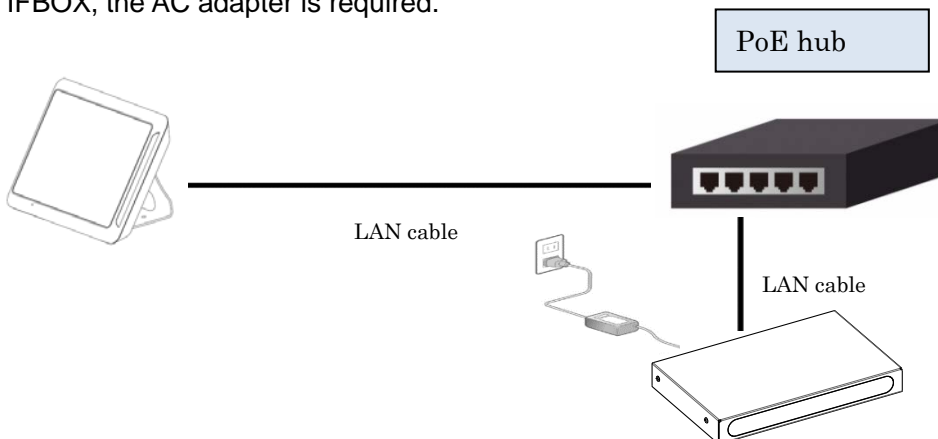

Note

- For details of the system configuration, visit the Elmo official website or contact the dealer from whom you have purchased this product or our branch/office near your location.
<https://www.elmoussa.com>
- Use a straight LAN cable for hub connections.

Fixing the IFBOX to a desk

The IFBOX can be fixed to a desk with screws.

When fixing the IFBOX to a desk, use M3 screws (pitch 0.5 mm) with a length that allows you to insert 3 to 10 mm from the bottom of the main unit.

- Fixing image

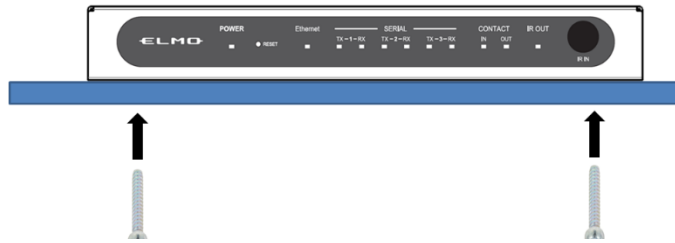

- Dimensions

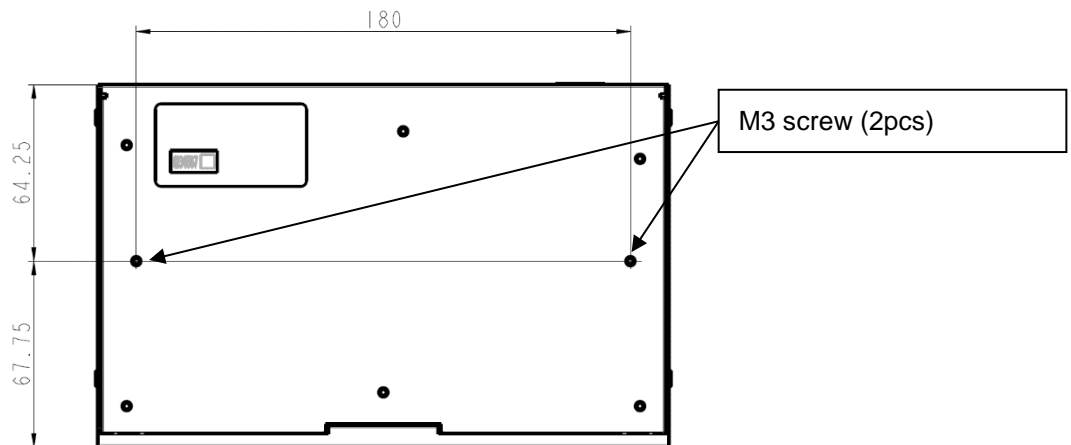

Caution:

Select the screw that matches the thickness of the desk.

(For example, if the desk is 20 mm thick, use 23 to 30 mm screws.)

Using the rubber foot

If the main unit is not fixed to a desk, use the included rubber foot to prevent slipping.

Attach 4pcs of the rubber foot to each corner of the bottom of the main unit.

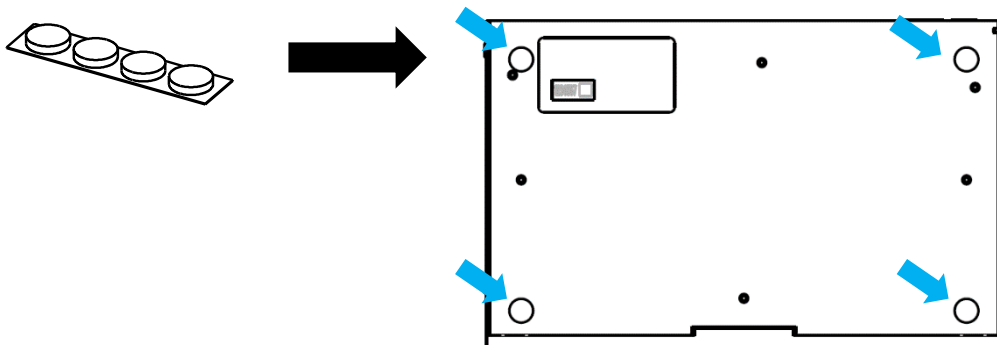

◆Connecting to a network

Connect the IFBOX and your computer with LAN cable.
(※The LAN cable is not included in the product.)

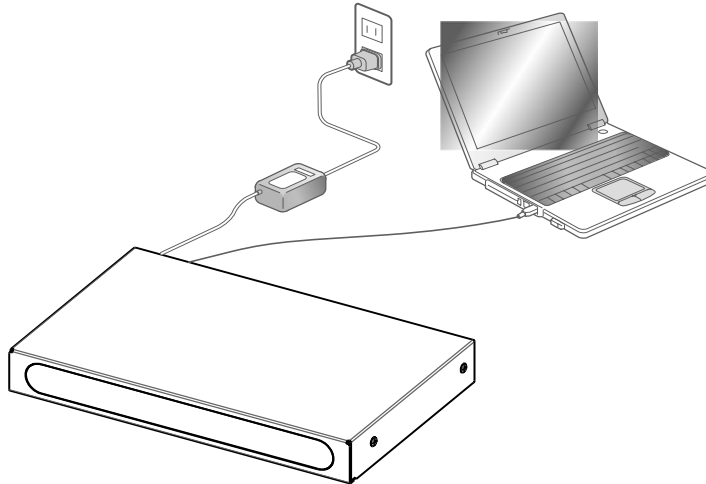

Connect the AC adapter and turn on the power.
Wait for about 1 minute for the IFBOX to start up.

The following options are available to connect the IFBOX to a network.

- Connect via TCP/IP

Enter the IP address 【192.168.1.100】 and Port number 【5136】 to connect.

- Connect via a browser

Enter the IP address 【192.168.1.100】 to the URL field of the browser.

Supported browsers: Google Chrome and Microsoft Edge

Note

- When connecting via TCP/IP, you can control the devices connected to the IFBOX and/or configure the serial settings of the IFBOX. ⇒P.22
- When connecting via a browser, you can configure the network settings and/or update the firmware. ⇒P.17
- For details of the network settings, visit the Elmo official website or contact the dealer from whom you have purchased this product or our branch/office near your location.
<https://www.elmoussa.com>

③ Using the IFBOX

◆What you can do with the IFBOX

- (1) Configuration of the settings via a browser
- Configuration of various settings of the IFBOX
(Network settings such as IP address, Serial communication settings, and Contact input settings)
 - Firmware update of the IFBOX
 - Download of the system log file of the IFBOX

(※1) The remote control commands that can be learned are NEC format, AEHA format, SONY format, remote control commands for PX series and L-12F/L-12W.

If the remote control command is a proprietary command, learning may not be possible even if it is in NEC format, AEHA format, or SONY format.

(※2) Usable remote control commands are the only commands which are learned by IFBOX can be sent. The commands are learned by other remote learning device won't work on the IFBOX.

- (2) Operations by sending commands via TCP/IP
- Operation of devices connected to the IFBOX
(Command transmission to an external serial device and control of the relay contact output)
 - Acquiring the status of devices connected to the IFBOX
(Acquisition of the status of the Contact input port)
 - Learning of the remote control commands being input to the IFBOX (* 1)
 - Transmission of the remote control commands that the IFBOX learned (* 2)
 - Control of commands received from external serial devices

◆ Configuration of the settings via a browser

Browser protocol specifications

Protocol	TCP
Default IP address	192.168.1.100 (can be changed)
Default Subnet mask	255.255.255.0 (can be changed)
Internet protocol version	IPv4
Supported browsers	Google Chrome, Microsoft Edge

Enter the IP address 【192.168.1.100】 to the URL field of the browser and the Settings screen appears.

Language ▾ Auth settings

Settings screen Firmware update SYSLOG download

Settings screen

IFBOX version:1.1.2 (Main FW:1.1.2 / Sub FW:1.0.1)

Serial number: 0000000

MAC address: 00:09:9a:00:00:00

IP address

Net mask

Gateway

Primary DNS

Secondary DNS

Port number

	Baudrate	Data bits	Parity bit	Stop bit	Flow control
Serial 1	<input type="text" value="9600"/>	<input type="text" value="8"/>	<input type="text" value="None"/>	<input type="text" value="1"/>	<input type="text" value="None"/>
Serial 2	<input type="text" value="9600"/>	<input type="text" value="8"/>	<input type="text" value="None"/>	<input type="text" value="1"/>	
Serial 3	<input type="text" value="9600"/>	<input type="text" value="8"/>	<input type="text" value="None"/>	<input type="text" value="1"/>	

Contact input 1 Contact input 2 Contact input 3 Contact input 4

Contact

■ Change display language

The language displayed on the browser can be changed from "Language".
The languages that can be displayed are as follows.

English, Japanese

The table below shows the items and default values that can be set on the Settings screen.

Item	Description
IP address	To set the IP address of the IFBOX
Net mask	To set the net mask of the IFBOX
Gateway	To set the gateway of the IFBOX
Primary DNS	To set the primary DNS of the IFBOX
Secondary DNS	To set the secondary DNS of the IFBOX
Port number	To set the port number used for TCP/IP communications of the IFBOX
Baud rate	To set the baud rate of the Serial port (1-3)
Data bit	To set the data bit of the Serial port (1-3)
Parity bit	To set the parity bit of the Serial port (1-3)
Stop bit	To set the stop bit of the Serial port (1-3)
Flow control (For the Serial port 1 only)	To set the flow control of the Serial port 1
Type of contact input	To set the contact type of the Contact input port (1-4)

Default setting values

- Network
 - IP address : 192.168.1.100
 - Net mask : 255.255.255.0
 - Gateway : 192.168.1.1
 - Primary DNS : 192.168.1.1
 - Secondary DNS : 192.168.1.1
 - Port number : 5136
- Serial port 1-3
 - Baud rate : 9600
 - Data bit : 8
 - Parity bit : None
 - Stop bit : 1
 - Flow control (for the Serial port 1 only) : None
- Type of contact input
 - Contact input port 1 : make
 - Contact input port 2 : make
 - Contact input port 3 : make
 - Contact input port 4 : make

Note

- If you execute the command to switch the type of contact input (P.31) and change the contact type from [make] to [break], the response from the IFBOX will also change from <HI> to <LO>.
- (If the contact type is [make] and the response from the IFBOX is <LO>, the response will be <HI>.)
- In order to change network settings such as IP address, you need to enable javascript in your browser.

Each setting value can be set from the Settings screen. Enter the necessary information and click [Update]. The window asking to restart appears. Click "Restart".

Language Auth settings

Settings screen Firmware update SYSLOG download

Settings screen

IFBOX version:1.1.2 (Main FW:1.1.2 / Sub FW:1.0.1)
 Serial number: 0000000
 MAC address: 00:09:9a:00:00:00

IP address:
 Net mask:
 Gateway:
 Primary DNS:
 Secondary DNS:
 Port number:

	Baudrate	Data bits	Parity bit	Stop bit	Flow control
Serial 1	9600	8	None	1	None
Serial 2	9600	8	None	1	
Serial 3	9600	8	None	1	

Contact input 1 Contact input 2 Contact input 3 Contact input 4
 Contact:

Save **Cancel** **Initialize**

Click



The setting value has been updated successfully.
 Restart IFBOX.
 It takes about one minute to restart IFBOX after pressing the Restart button.

Restart

Click

Item	Value
IP address	
Net mask	
Gateway	0.0.0.0-255.255.255.255
Primary DNS	
Secondary DNS	
Port number	1024-65535
Baud rate	1200 · 2400 · 4800 · 9600 19200 · 38400 · 57600 115200 · 203400
Data bit	7 8
Parity bit	None Odd Even
Stop bit	1 2
Flow control (For the Serial port 1 only)	None RTS/CTS
Type of contact input	Make Break

Note

By pressing the "Reset" button at the bottom right of the Settings screen, the following items can be reset to factory default settings.

IP address, Net mask, Gateway, Primary DNS, Secondary DNS, Port number

Baud rate, Data bit, Parity bit and Stop bit for the Serial port (1-3)

Authentication settings, Login password, Type of contact input for the Contact input port (1-4)

Flow control for the Serial port 1

■Firmware update

The firmware of the IFBOX can be updated from the Firmware Update menu in the Settings screen.

Click “Select file” and select the update file “ifboxupdate.zip”.
Click “Firmware Update” to start the update.

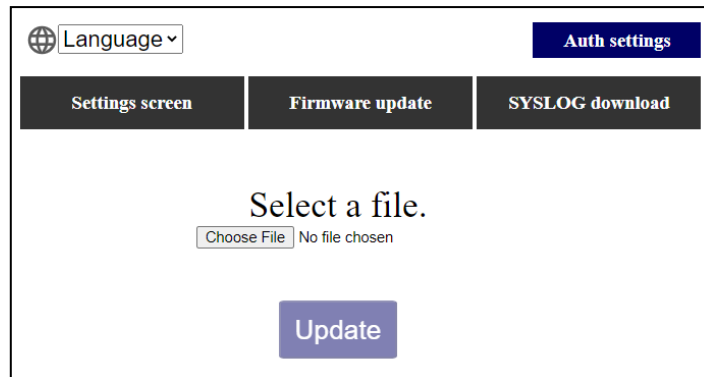

If the firmware update is successful, the following message is displayed. Restart the IFBOX. It takes about 1 minute to complete the restart process.

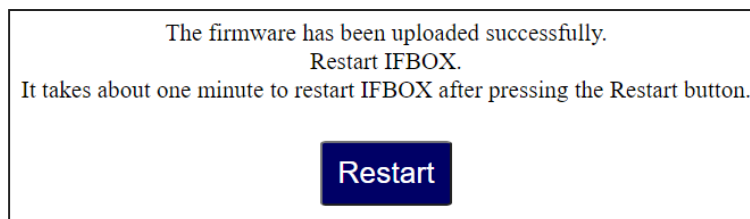

Note

For the update file, contact the dealer where you purchased this product.

■Download of the system log file

The system log file can be downloaded from the SYSLOG Download menu in the Settings screen. Click “Download” to start the download.



Note

Only system logs after startup can be downloaded. When the power is turned off, all the logs up to that point will be lost.

■ Authentication settings (Password setting)

The password can be set from the Authentication settings menu in the Settings screen.

Auth settings screen

Auth screen Use Do not use

Current Password

New Password

Confirm Password

Change **Cancel**

The default setting values of the Authentication settings screen are as follows.

Default setting values

- Authentication settings screen : Do not use
- Password : root

● How to change the password

1. Check off “Use” for the Authentication screen option.
2. Enter the current password. If no password has been set yet, enter “root”.
3. Enter a new password.
4. Enter a new password again to the password confirmation field.
5. Click “Save”.

• Authentication screen option

Use : The Login screen appears when accessing a browser.

Do not use : The Settings screen appears when accessing a browser.

• Password

The password can be set with a minimum of 1 character and a maximum of 8 characters.

The characters that can be used in the password are as follows.

Numbers	Characters	Symbols	Others
0-9	a-z A-Z	! & ~ * _ [. " ' } - ; / # (` < ^ : \$) { > ¥] % = + ? @ ,	space

Note

The default password is “root”.

■ Login screen

If you select "Use" for the Authentication screen option, enter the password created in the Authentication settings screen.

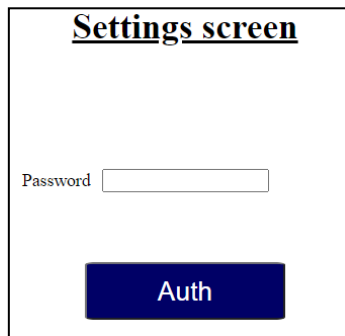

The screenshot shows a window titled "Settings screen". Inside the window, there is a label "Password" followed by a text input field. Below the input field is a dark blue button with the text "Auth" in white.

Note

In case you forgot your password, press the Factory default reset switch. ⇒P.11

◆ TCP/IP specifications

In this manual, a device that sends commands to the IFBOX via wired LAN is referred to as the controller.

TCP/IP is used for communication between the controller and the IFBOX.

The IFBOX works as a server and the controller works as a client.

The communication specifications are as follows.

Protocol	TCP
Default IP address	192.168.1.100 (can be changed)
Default Subnet mask	255.255.255.0 (can be changed)
Default Port number	5136 (can be changed)
Internet protocol version	IPv4

In order for the controller to operate the IFBOX, the TCP/IP connection with the IFBOX is required. The controller identifies the IFBOX by IP address.

Note

- Up to 10 controllers can be connected to the IFBOX at the same time.
- If the controller connected to the IFBOX has not been operated for 5 minutes or more, the session will be automatically disconnected.
- The IP address, Subnet mask, and Port number to be used can be changed from the browser (⇒P.17).
- When sending commands from the controller to the IFBOX, make sure to keep at least 1 second interval between each command.

■Using the IFBOX with TCP/IP

The IFBOX performs the controls according to the command received via TCP/IP.

The communication is done by exchanging "request command" and "response command".

- Request command : After receiving the request command from the controller, the IFBOX performs the requested control.
- Response command : The IFBOX sends the result (success or failure) of the processing of the request command to the controller.
- Response command 2 : The IFBOX sends the command received from the external serial device to the controller.
- Response command 3 : The IFBOX sends the acquired status of the Contact input port to the controller.
- Response command 4 : The IFBOX sends the result of the remote control learning to the controller.
- Response command 5 : The IFBOX sends the learned remote control command to the controller.

Note

When the controller requests the IFBOX for a remote control learning command, the IFBOX sends the response command to the controller first.

If the response command is <OK>, the IFBOX starts the remote control learning and sends the result to the controller as "response command 4".

When the controller requests the IFBOX for learned remote control command, the IFBOX sends the response command to the controller first.

If the response command is <OK>, the IFBOX sends the remote control learning command as "response command 5" to the controller.

■Command format

The following table shows the command format used for the communication with the IFBOX. Commands are exchanged in this format between the controller and the IFBOX.

※The characters inside < and > symbols are written in ASCII code.

Other characters are written in hexadecimal

In ASCII code, 1 character is 1 byte, and in hexadecimal number, 2 characters are 1 byte.

(Example: <X> =1byte, *XX* (italic) =1byte)

Note

ASCII code is one of the character codes that contains alphabets, numbers, symbols, etc., and represents characters as 7-bit values (0-127).

The information about the ASCII code can be found in books or on the Internet.

- Header : It is added to the beginning of each command. The header is always (0x55AA) for any command.
- COMMAND length : Indicates the combined length of BoxID, DeviceID, and Contents. The maximum size of COMMAND is 0xFF.

- **BoxID** : Indicates the ID of the IFBOX used when sending commands from the IFBOX to the controller or when sending commands from the controller to the IFBOX.
BoxID is represented by 2 byte code from <00> to <99>.
BoxID that was last used by the IFBOX to control the device is retained until the IFBOX is restarted.
(For example, if the IFBOX used <12> as BoxID to control a device and then used <34> as BoxID to control another device, <34> will be retained as BoxID until the IFBOX is restarted.)
- **DeviceID** : Indicates the device to be controlled by the IFBOX.
Device ID is represented by 3 byte code such as <XXX>.
※For information about Device IDs that can be used, refer to the explanation page of each function of the IFBOX in this manual.
- **Contents** : The content of the control command is described here. The maximum size of Contents is 250byte.
Details of the commands that can be described in Contents will be explained on the following pages.

Name	Header	COMMAND length	COMMAND		
			BoxID	DeviceID	Contents
Value	55AA	FF (max.)	<00> - <99>	<XXX>	Any command
Size	2byte	1byte	2byte	3byte	250byte (max.)

Note

When using a hexadecimal number for the command, be sure to describe it in 1-byte (8-bit) units. For example, when using the following command, describe the length of COMMAND as "09" instead of "9".

<Situation>

Request from controller: Specifying <17> as BoxID, send <TEST> from the Serial port 1 to the connected device

Result: Command is processed successfully.

Correct: 55AA09<17SC1TEST>

Wrong: 55AA9<17SC1TEST>

■Response command format

After receiving the command from the controller, the IFBOX processes the command and sends a response command to the controller.

The IFBOX describes <OK> if the processing of the command is successful and <NG> if it failed in the Contents part, and sends it.

Same BoxID and DeviceID used in the received command are also used in the command to be returned.

Name	Header	COMMAND length	COMMAND		
			BoxID	DeviceID	Contents
Value	55AA	07	<00> - <99>	<XXX>	<OK> <NG>
Size	2byte	1byte	2byte	3byte	2byte

Command example)

<Situation>

Request from controller: Specifying <17> as BoxID, send <TEST> from the Serial port 1 to the connected device

Result: Command is processed successfully.

※The characters inside < and > symbols are written in ASCII code.

Other characters are written in hexadecimal

In ASCII code, 1 character is 1 byte, and in hexadecimal number, 2 characters are 1 byte.
(Example: <X> =1byte, *XX* (italic) =1byte)

•Request command (Controller → IFBOX)

55AA09<17SC1TEST>

•Response command (IFBOX → Controller)

55AA07<17SC1OK>

An example of the IFBOX sending <NG> to the controller is if a command outside the specification is used for Device ID.

•Request command (Controller → IFBOX)

55AA09<14XYZTEST>

•Response command (IFBOX → Controller)

55AA07<17XYZNG>

■ Sending a command to a serial device

The IFBOX sends an arbitrary command received from the controller to the device connected to the Serial port.

Request command

Data direction	Controller → IFBOX					
Name	Header	COMMAND length	COMMAND			Description
			BoxID	DeviceID	Contents	
Value	55AA	Arbitrary length When Contents is 1byte: 06 When Contents is 250byte: FF (max.)	<00> - <99>	<SC1> <SC2> <SC3>	Arbitrary command	Send a command described in Contents from the Serial port (1-3)
Size	2byte	1byte	2byte	3byte	250byte (max.)	

Response command

Data direction	IFBOX → Controller					
Name	Header	COMMAND length	COMMAND			Description
			BoxID	DeviceID	Contents	
Value	55AA	07	<00> - <99>	<SC1> <SC2> <SC3>	<OK> <NG>	<OK> if command transmission from the Serial port (1-3) is successful <NG> if failed
Size	2byte	1byte	2byte	3byte	2byte	

Command example)

<Situation>

Request from controller: Specifying <17> as BoxID, send <TEST> from the Serial port 1 to the connected device

Result: Command is processed successfully.

※The characters inside < and > symbols are written in ASCII code.

Other characters are written in hexadecimal

In ASCII code, 1 character is 1 byte, and in hexadecimal number, 2 characters are 1 byte.

(Example: <X> =1byte, *XX* (italic) =1byte)

•Request command (Controller → IFBOX)

55AA09<17SC1TEST>

•Response command (IFBOX → Controller)

55AA07<17SC1OK>

★Example of sending 0xab and 0xcd to SC1 with header 0x02 and footer 0x03

•Request command (Controller → IFBOX)

55AA09<17SC1>02abcd03

The length of COMMAND is 9 bytes in total. (5 bytes for <17SC1> and 4 bytes for 02abcd03)

■Receiving a command from a serial device

When an arbitrary command is sent to the IFBOX from an external device connected to the Serial port of the IFBOX, the IFBOX sends the received command to the controller.

The controller to which the IFBOX sends is all the controllers that are connected to the IFBOX.

Response command 2

Data direction	IFBOX → Controller					
Name	Header	COMMAND length	COMMAND			Description
			BoxID	DeviceID	Contents	
Value	55AA	Arbitrary length When Contents is 1byte: 06 When Contents is 250byte: FF (max.)	<00> - <99>	<SC1> <SC2> <SC3>	Arbitrary command	Send the command received from the external device to the controller from the Serial port (1-3)
Size	2byte	1byte	2byte	3byte	250byte (max.)	

Command example)

<Situation>

Specifying <17> as BoxID, the IFBOX sends < SERIAL > received from the external device to the Serial port 1 to the controller.

※The characters inside < and > symbols are written in ASCII code.

Other characters are written in hexadecimal

In ASCII code, 1 character is 1 byte, and in hexadecimal number, 2 characters are 1 byte.

(Example: <X> =1byte, *XX* (italic) =1byte)

(IFBOX → Controller)

55AA0B<17SC1SERIAL>

■ Contact output port control

The IFBOX sends <HI> or <LO> command received from the controller to the device connected to the Contact output port (1-8) of the IFBOX.

It is also possible to control <HI> or <LO> for all the Contact output ports (1-8) with a single command.

<LO> : Open contacts

<HI> : Close contacts

Request command

Data direction	Controller → IFBOX					
Name	Header	COMMAND length	COMMAND			Description
			BoxID	DeviceID	Contents	
Value	55AA	07	<00> - <99>	<CO1> <CO2> <CO3> <CO4> <CO5> <CO6> <CO7> <CO8>	<HI> <LO>	Specify the output from the Contact output port (1-8)
				<COA>	<00> - <FF>	Specify the output from all the Contact output ports Specify <HI> with 1 and <LO> with 0 in Contents (8 bit) The most significant bit is represented by <CO8> and the least significant bit is represented by <CO1>.
Size	2byte	1byte	2byte	3byte	2byte	

Response command

Data direction	IFBOX → Controller					
Name	Header	COMMAND length	COMMAND			Description
			BoxID	DeviceID	Contents	
Value	55AA	07	<00> - <99>	<CO1> <CO2> <CO3> <CO4> <CO5> <CO6> <CO7> <CO8> <COA>	<OK> <NG>	<OK> if command processing is successful <NG> if failed
Size	2byte	1byte	2byte	3byte	2byte	

Command example 1) When using any of the commands from <CO1> to <CO8>

<Situation>

Request from controller: Specifying <17> as BoxID, send <HI> from the Serial port 1

Result: Command is processed successfully.

※The characters inside < and > symbols are written in ASCII code.

Other characters are written in hexadecimal

In ASCII code, 1 character is 1 byte, and in hexadecimal number, 2 characters are 1 byte.

(Example: <X> =1byte, *XX* (italic) =1byte)

•Request command (Controller → IFBOX)

55AA07<17CO1HI>

•Response command (IFBOX → Controller)

55AA07<17CO1OK>

Command example 2) When using <COA> command

<Situation>

Request from controller: Specifying <17> as BoxID, send <HI> to the Contact output port 1, 3, 4, 8 and <LO> to the Contact output 2,5,6,7

Result: Command is processed successfully.

※The characters inside < and > symbols are written in ASCII code.

Other characters are written in hexadecimal

In ASCII code, 1 character is 1 byte, and in hexadecimal number, 2 characters are 1 byte.

(Example: <X> =1byte, *XX* (italic) =1byte)

•Request command (Controller → IFBOX)

55AA07<17COA8D>

•Response command (IFBOX → Controller)

55AA07<17COAOK>

■ Contact input port control

In response to the command from the controller, IFBOX acquires the status of the Contact input port (1-4) and sends <HI> or <LO> to the controller. It is also possible to acquire the <HI> <LO> status for all the Contact input ports (1-4) with a single command.

·When type of contact input is [make] (default setting)

Close the contact : <LO> is detected.

Open the contact : <HI> is detected.

·When type of contact input is [break]

Open the contact : <LO> is detected.

Close the contact : <HI> is detected.

Note

For details of the type of contact input, refer to P.33.

Request command

Data direction	Controller → IFBOX					
Name	Header	COMMAND length	COMMAND			Description
			BoxID	DeviceID	Contents	
Value	55AA	07	<00> - <99>	<CI1> <CI2> <CI3> <CI4> <CIA>	<RQ>	Acquire the status of the Contact input port (1-4)
Size	2byte	1byte	2byte	3byte	2byte	

Response command 3

Data direction	IFBOX → Controller					
Name	Header	COMMAND length	COMMAND			Description
			BoxID	DeviceID	Contents	
Value	55AA	07	<00> - <99>	<CI1> <CI2> <CI3> <CI4>	<HI> <LO>	Return the status of the Contact input port (1-4) with <HI> or <LO>
				<CIA>	<00> - <0F>	The status of the Contact input port (1-4) is expressed with the Contents command (8bit). The lower 4 bits are used. The upper 4 bits are fixed at 0. <HI> is represented by 1 and <LO> is represented by 0. The 3rd bit represents the <CI4> state, the 2nd bit represents the <CI3> state, the 1st bit represents the <CI2> state, and the 0th bit (least significant bit) represents the <CO1> state.
Size	2byte	1byte	2byte	3byte	2byte	

Command example1) When using any of the commands from <CI1> to <CI4>

<Situation>

Request from controller: Acquire the status of the Contact input port 1

Result: The IFBOX returned <HI>, specifying <17> as BoxID.

※The characters inside < and > symbols are written in ASCII code.

Other characters are written in hexadecimal

In ASCII code, 1 character is 1 byte, and in hexadecimal number, 2 characters are 1 byte.

(Example: <X> =1byte, *XX* (italic) =1byte)

•Request command (Controller → IFBOX)

55AA07<17CI1RQ>

•Response command (IFBOX → Controller)

55AA07<17CI1HI>

Command example 2) When using <CIA> command

<Situation>

Request from controller: Acquire the status of the Contact input port 1-2 and Contact output port 3-4

Result: Specifying <17> as BoxID, the IFBOX returned <HI> for the Contact input port 1-2 and <LO> for the Contact output port 3-4.

※The characters inside < and > symbols are written in ASCII code.

Other characters are written in hexadecimal

In ASCII code, 1 character is 1 byte, and in hexadecimal number, 2 characters are 1 byte.

(Example: <X> =1byte, *XX* (italic) =1byte)

•Request command (Controller → IFBOX)

55AA07<17CIARQ>

•Response command (IFBOX → Controller)

55AA07<17CIA03>

■ Switching the contact type of the Contact input ports

The controller sends a command to switch the contact type of the Contact input ports (1-4) of the IFBOX.

Request command

Data direction	Controller → IFBOX					
Name	Header	COMMAND length	COMMAND			Description
			BoxID	DeviceID	Contents	
Value	55AA	06	<00> - <99>	<CM1> <CM2> <CM3> <CM4>	<a> 	Change the contact type of the Contact input port (1-4) <a> means [make], means [break] (※1)
Size	2byte	1byte	2byte	3byte	1byte	

(※1) If <HI> is returned when contact type is <a>, the IFBOX will return <LO> by changing the contact type to .

If <LO> is returned when contact type is <a>, the IFBOX will return <HI> by changing the contact type to .

Response command

Data direction	IFBOX → Controller					
Name	Header	COMMAND length	COMMAND			Description
			BoxID	DeviceID	Contents	
Value	55AA	07	<00> - <99>	<CM1> <CM2> <CM3> <CM4>	<OK> <NG>	<OK> if the contact type of the Contact input port (1-4) is changed successfully <NG> if failed
Size	2byte	1byte	2byte	3byte	2byte	

Command example

<Situation>

Request from controller: Specifying <17> as BoxID, change the contact type of the Contact input port 1 to

Result: Command is processed successfully.

※The characters inside < and > symbols are written in ASCII code. Other characters are written in hexadecimal. In ASCII code, 1 character is 1 byte, and in hexadecimal number, 2 characters are 1 byte. (Example: <X> =1byte, *XX* =1byte)

•Request command (Controller → IFBOX)

55AA06<17CM1b>

•Response command (IFBOX → Controller)

55AA07<17CM1OK>

■ Serial port status settings

This section explains the commands for status settings of 3 Serial ports of the IFBOX. The items that can be set are the baud rate, data bit, parity bit, and stop bit.

Request command

Data direction	Controller → IFBOX					
Name	Header	COMMAND length	COMMAND			Description
			BoxID	DeviceID	Contents	
Value	55AA	0F – 11	<00> - <99>	<SB1> <SB2> <SB3>	See below for details.	Set the Serial port (1-3)
Size	2byte	1byte	2byte	3byte	10byte - 12byte	

Response command

Data direction	IFBOX → Controller					
Name	Header	COMMAND length	COMMAND			Description
			BoxID	DeviceID	Contents	
Value	55AA	07	<00> - <99>	<SB1> <SB2> <SB3>	<OK> <NG>	<OK> if the setting of the Serial port (1-3) is successful <NG> if failed
Size	2byte	1byte	2byte	3byte	2byte	

The command to be described in Contents when Device ID is SB1, SB2, SB3 are described below.

	Contents						
Name	Baud rate	Delimiter	Data bit	Delimiter	Parity bit	Delimiter	Stop bit
Value	<1200>	<.>	<7> <8>	<.>	<n> <e> <o>	<.>	<1> <2>
	<2400>						
	<4800>						
	<9600>						
	<19200>						
	<38400>						
	<57600>						
	<115200>						
	<230400>						
Size	4byte – 6byte	1byte	1byte	1byte	1byte	1byte	1byte

Delimiter: <.> is used to indicate the separation of each setting value.

Baud rate: Indicates the baud rate to be set.

Data bit: Indicates the data bit (7bit/8bit) to be set.

Parity bit: Indicates the parity bit (<n>: None, <e>: Even, <o>: Odd) to be set.

Stop bit: Indicates the stop bit (1bit/2bit) to be set.

Note

Flow control settings can be set only for the Serial port 1 and only from the browser.

Command example

※The characters inside < and > symbols are written in ASCII code.

Other characters are written in hexadecimal

In ASCII code, 1 character is 1 byte, and in hexadecimal number, 2 characters are 1 byte.

(Example: <X> =1byte, *XX* (italic) =1byte)

When setting the baud rate, data bit, parity bit, and stop bit of the Serial port 1 to “19200”, “8 bit”, “None”, and “1 bit” respectively

•Request command (Controller → IFBOX)

`55AA10<17SB119200.8.n.1>`

•Response command (IFBOX → Controller)

`55AA07<17SB1OK>`

When setting the baud rate, data bit, parity bit, and stop bit of the Serial port 2 to “115200”, “7 bit”, “Even”, and “2 bit” respectively

•Request command (Controller → IFBOX)

`55AA11<17SB2115200.7.e.2>`

•Response command (IFBOX → Controller)

`55AA07<17SB2OK>`

When setting the baud rate, data bit, parity bit, and stop bit of the Serial port 3 to “1200”, “8 bit”, “Odd”, and “1 bit” respectively

•Request command (Controller → IFBOX)

`55AA0F<17SB31200.8.o.1>`

•Response command (IFBOX → Controller)

`55AA07<17SB2OK>`

■ Remote control learning

The IFBOX has a remote control learning function.

The IFBOX's remote control learning is realized by saving the learned remote control command on the local computer.

Prepare the IFBOX, the remote control you want to learn, and a computer and connect the computer and the IFBOX via a wired LAN. (The figure below shows a connection example.) The remote control learning is performed using the dedicated learning software "SynCVASIRLearning" installed on the computer.

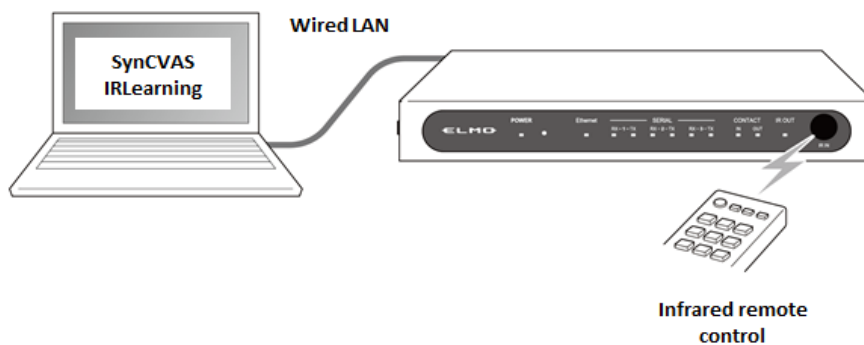

Note

- The remote control learning tool is included in SynCVAS Designer.
- Refer to the SynCVAS Designer instruction manual for how to create edit data and how to download data from a computer to a USB flash drive or SD card.
- The SynCVAS Designer instruction manual is not included with the IFBOX. Visit the Elmo official website or contact the dealer from whom you have purchased this product or our branch/office near your location. <https://www.elmoussa.com>

Follow the steps below to perform the remote control learning.

1. Send the first command for the remote control learning from the controller to the IFBOX via TCP/IP. Then point the remote control at the IR receiver of the IFBOX and send the remote control command to be learned.

If the learning is successful, the IFBOX sends a response command to the controller with the Contents <FLSOK>.

If the learning failed, the IFBOX sends a response command to the controller with the Contents <FLSNG>. In this case, send the first command again and retry.

2. After the first remote control learning is completed successfully, send the second command for the remote control learning from the controller to the IFBOX.

Then point the remote control at the IR receiver of the IFBOX and send the same command as the first remote control learning.

If the learning is successful, the IFBOX sends a response command to the controller with the Contents <SLSOK>.

If the learning failed, the IFBOX sends a response command to the controller with the Contents <SLSNG>. In this case, send the second command again and retry.

3. After the second remote control learning is completed successfully, send the command for acquiring the learned remote control command to the IFBOX.
If the command received from the controller is processed successfully, the IFBOX returns <OK> to the controller and sends the learned remote control command.
If the IFBOX failed to process the command from the controller, send the first remote control learning command again and retry.
4. The controller saves the learned remote control command received from the IFBOX.

■ Commands for remote control learning

Request command

Data direction	Controller → IFBOX					
Name	Header	COMMAND length	COMMAND			Description
			BoxID	DeviceID	Contents	
Value	55AA	07	<00> - <99>	<IR1>	<FLS>	Start the first remote control learning
					<SLS>	Start the second remote control learning
					<SLR>	Acquire the learned remote control command
					<ELM>	End the remote control learning forcibly
Size	2byte	1byte	2byte	3byte	3byte	

Response command

Data direction	IFBOX → Controller					
Name	Header	COMMAND length	COMMAND			Description
			BoxID	DeviceID	Contents	
Value	55AA	07	<00> - <99>	<IR1>	<OK> <NG>	<OK> if the processing of the first remote control learning command is successful <NG> if failed
						<OK> if the processing of the second remote control learning command is successful <NG> if failed
						Acquire the learned remote control command
						End the remote control learning forcibly
Size	2byte	1byte	2byte	3byte	2byte	

Response command 4

Data direction	IFBOX → Controller					
Name	Header	COMMAND length	COMMAND			Description
			BoxID	DeviceID	Contents	
Value	55AA	0A	<00> - <99>	<IR1>	<FLSOK> <FLSNG>	<FLSOK> if the first remote control learning is successful <FLSNG> if failed
					<SLSOK> <SLSNG>	<SLSOK> if the second remote control learning is successful <SLSNG> if failed
Size	2byte	1byte	2byte	3byte	5byte	

Response command 5

Data direction	IFBOX → Controller					
Name	Header	COMMAND length	COMMAND			Description
			BoxID	DeviceID	Contents	
Value	55AA	User-defined length (Max. FF)	<00> - <99>	<IR1>	See below for details.	Send the learned remote control command to the controller
Size	2byte	1byte	2byte	3byte	Max. 250byte	

The following table is described the learned remote control signal (Contents).

※The characters inside < and > symbols are written in ASCII code.

Other characters are written in hexadecimal

In ASCII code, 1 character is 1 byte, and in hexadecimal number, 2 characters are 1 byte.

(Example: <X> =1byte, XX (italic) =1byte)

Meaning of commands	Contents				Compatible manufacturers (※2)
	Format	Remote control data size (in bit)	Remote control data	Repeat code (Yes/No)	
NEC format	<SRSN>	20	XXXXXXXX	00 : No 01 : Yes	NEC, Sanyo, Toshiba, Hitachi, etc.
AEHA format	<SRSK>	30(※1)	XXXXXXXXXXXXXX	00 : No 01 : Yes	Sharp, Panasonic, etc.
SONY format	<SRSS>	0C	XXXX(※3)	00 : No	SONY
		0F	XXXX(※4)		
		14	XXXXXX(※3)		
Format used for remote control for L-12F/L-12W (Elmo proprietary format)	<SRSN>	20	XXXXXXXX	00 : No	
Format used for remote control for PX series (Elmo proprietary format)	<SRSP>	20	XXXXXXXX	00 : No	

* 1: The remote control data size may change depending on the remote control used.

* 2: Learning may not be possible with some remote controllers of the manufacturer listed.

* 3: The lower 4 bit are always 0.

* 4: The least significant bit is always 0.

Examples of learned remote control command (assuming BoxID as <17>)

NEC format (no repeat code)

55AA0F<17IR1SRSN>200123456700

NEC format (have repeat code)

55AA0F<17IR1SRSN>200123456701

AEHA format (no repeat code)

55AA11<17IR1SRSK>300123456789ab00

AEHA format (have repeat code)

55AA11<17IR1SRSK>300123456789ab01

SONY format (12bit)

55AA0D<17IR1SRSS>0C012000

SONY format (15bit)

55AA0D<17IR1SRSS>0F012200

SONY format (20bit)

55AA0E<17IR1SRSS>1401234000

Format used for remote control for PX series

55AA11<17IR1SRSP>300123456789ab00

Format used for remote control for L-12F/L-12W

55AA0F<17IR1SRSL>200123456700

■ Example of how to perform remote control learning

The below explains how the remote control learning is performed in NEC format.

※The characters inside < and > symbols are written in ASCII code.

Other characters are written in hexadecimal

In ASCII code, 1 character is 1 byte, and in hexadecimal number, 2 characters are 1 byte.

(Example: <X> =1byte, *XX* (italic) =1byte)

- Format : <SRSN>
- Remote control data size : 20
- Remote control data : *80D65764*
- Repeat code : 01

(1) The first remote control learning

The controller sends the command for the first remote control learning.

- Request command (Controller → IFBOX)
55AA07<17IR1FLS>

Immediately after, the IFBOX returns the result of whether the processing of the command from the controller is successful or failed.

- Response command (IFBOX → Controller)
55AA07<17IR1OK> : if successful
55AA07<17IR1NG> : if failed

If the command processing from the controller is successful, the IFBOX will be in the waiting state for the remote control command.

In this state, if the remote control command to be learned is sent from a commercially available remote control to the IR receiver of the IFBOX, the result of success or failure of the first remote control learning will be returned.

- Response command (IFBOX → Controller)
55AA07<17IR1FLSOK> : if successful
55AA07<17IR1FLSNG> : if failed

This is the process of the first remote control learning.

If the first remote control learning is successful, then the second remote control learning is performed.

If the first remote control learning failed, execute the <FLS> command and retry the first remote control learning.

To end the remote control learning, execute the <ELM> command.

(2) The second remote control learning

The controller sends the command for the second remote control learning.

- Request command (Controller → IFBOX)
55AA07<17IR1SLS>

Immediately after, the IFBOX returns the result of whether the processing of the command from the controller is successful or failed.

- Response command (IFBOX → Controller)
55AA07<17IR1OK> : when successful
55AA07<17IR1NG> : when failed

If the command processing from the controller is successful, the IFBOX will be in the waiting state for the remote control command.

In this state, if the remote control command to be learned is sent from a commercially available remote control to the IR receiver of the IFBOX, the result of success or failure of the second remote control learning will be returned.

- Response command 4 (IFBOX → Controller)
55AA07<17IR1SLSOK> : when successful
55AA07<17IR1SLSNG> : when failed

This is the process of the second remote control learning.

If the second remote control learning is successful, then the acquisition of the learned remote control command is performed.

If the second remote control learning failed, execute the <FLS> command and retry the first remote control learning.

To end the remote control learning, execute the <ELM> command.

(3) Acquisition of the learned remote control command

The controller sends the command to acquire the learned remote control command.

- Request command (Controller → IFBOX)
55AA07<17IR1SLR>

Immediately after, the IFBOX returns the result of whether the processing of the command from the controller is successful or failed.

- Response command (IFBOX → Controller)
55AA07<17IR1OK> : if successful
55AA07<17IR1NG> : if failed

Then the IFBOX returns the learned remote control command to the controller.

The entire command becomes the learned remote control command.

- Response command 5 (IFBOX → Controller)
55AA0F<17IR1SRSN>2080D6576401

■Using learned remote control command

The IFBOX has a function to send the learned remote control command.

For details on how to use the learned remote control command, refer to "Add a macro" in the chapter "Operations of the SynCVAS IRLearning" in the SynCVAS Designer manual.

The transmission of the learned remote control command is performed according to the following steps.

1. The controller sends the learned remote control command to the IFBOX by the remote control command transmission command.

The IFBOX continues to send remote control command until it receives a command to stop sending remote control command.

2. The controller sends the command to stop the transmission of the remote control command to the IFBOX to end the remote control command transmission.

■Remote control command transmission commands

Request command

Data direction	Controller → IFBOX					
Name	Header	COMMAND length	COMMAND			Description
			BoxID	DeviceID	Contents	
Value	55AA	User-defined length (Max. FF)	<00> - <99>	<IR1>	Refer to P.40	Start remote control command transmission
		07			<SRT>	Stop remote control command transmission
Size	2byte	1byte	2byte	3byte	Max. 250byte	

Response command

Data direction	IFBOX → Controller					
Name	Header	COMMAND length	COMMAND			Description
			BoxID	DeviceID	Contents	
Value	55AA	07	<00> - <99>	<IR1>	<OK>	<OK> if the processing of the command to start transmission of the remote control command is successful
					<NG>	<NG> if failed
					<OK>	<OK> if the processing of the command to stop transmission of the remote control command is successful
					<NG>	<NG> if failed
Size	2byte	1byte	2byte	3byte	2byte	

■ Example of how to start/stop remote control command transmission

The below explains how to send remote control command in NEC format.

※The characters inside < and > symbols are written in ASCII code.

Other characters are written in hexadecimal

In ASCII code, 1 character is 1 byte, and in hexadecimal number, 2 characters are 1 byte.

(Example: <X> =1byte, *XX* (italic) =1byte)

In this example, the BoxID is set to <17>.

- Format : <SRSN>
- Remote control data size : 20
- Remote control data : *80D65764*
- Repeat code : 01

Start remote control command transmission

- Request command (Controller → IFBOX)
55AA0F<17IR1SRSN>2080D6576401

- Response command (IFBOX → Controller)
55AA07<17IR1OK> : if successful
55AA07<17IR1NG> : if failed

Stop remote control command transmission

- Request command (Controller → IFBOX)
55AA07<17IRSRT>

- Response command (IFBOX → Controller)
55AA07<17IR1OK> : if successful
55AA07<17IR1NG> : if failed

4 Troubleshooting

◆Symptom, possible cause, and remedy

Check the following items. If any abnormality is found, consult the dealer from whom you purchased this product or our nearest branch/office.

Symptom	Possible cause/ remedy
Cannot turn on the IFBOX.	<ul style="list-style-type: none">• Is the Power LED on? Check whether the AC adapter is connected properly.• Are extension cords or power strips used? Do not use extension cords or power strips, but connect directly to the wall outlet.• Use other wall outlet.• Restart the IFBOX by pressing the Reset switch on the main unit.
The IFBOX does not respond.	<ul style="list-style-type: none">• Check whether the network connection is normal.• Restart the IFBOX by pressing the Reset switch on the main unit.• Is the LED in the front of the main unit on?
The password for the Authentication settings screen does not respond.	<ul style="list-style-type: none">• Enter default password 【root】.• Press the Factory default reset switch on the side of the main unit to reset the IFBOX to factory default.

About long-term usage of the product

Due to the lifetime of its parts, if this product is used for longer than the warranty period, its performance and quality may deteriorate. In this case, we will replace the parts for a charge. Consult the dealer from whom you purchased this product or visit the Elmo official website.

<https://www.elmousa.com>

⑤ Specifications

Interface specifications

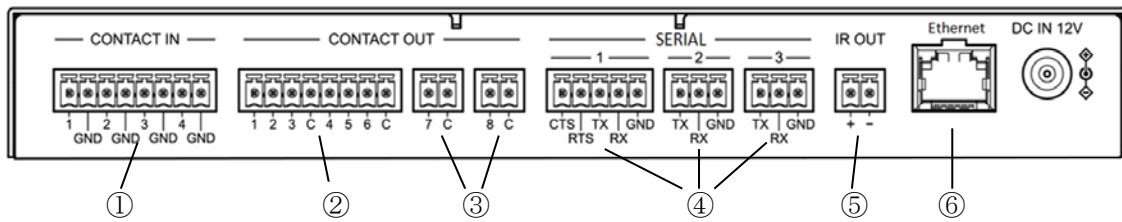

① CONTACT IN: Contact input port

Indication	Name	Note
1	Input 1	
G	GND	Common GND for all contact inputs
2	Input 2	
G	GND	Common GND for all contact inputs
3	Input 3	
G	GND	Common GND for all contact inputs
4	Input 4	
G	GND	Common GND for all contact inputs

② CONTACT OUT: Relay contact output port (1-6)

Indication	Name	Note
1	Output 1	
2	Output 2	
3	Output 3	
C	COM	Common port for the Contact output port 1, 2, 3
4	Output 4	
5	Output 5	
6	Output 6	
C	COM	Common port for the Contact output port 4, 5, 6

③ CONTACT OUT: Relay contact output port (7,8)

Indication	Name	Note
7	Output 7	
C	COM	Common port for the Contact output port 7
8	Output 8	
C	COM	Common port for the Contact output port 7

④ SERIAL port

<SERIAL 1>

Indication	Abbreviation	Name	Data direction IFBOX – Device	Note
CTS	CTS	Send permission	←	CTS:Clear To Send
RTS	RTS	Send request	→	RTS:Request To Send
TX	TXD	Transmitted data	→	TXD:Transmitted Data
RX	RXD	Received data	←	RXD:Received Data
GND	GND	Communication ground	-	GND:Ground

Data direction 「→」 : from IFBOX to device

Data direction 「←」 : from device to IFBOX

<SERIAL 2> <SERIAL 3>

Indication	Abbreviation	Name	Data direction IFBOX – Device	Note
TX	TXD	Transmitted data	→	TXD:Transmitted Data
RX	RXD	Received data	←	RXD:Received Data
GND	GND	Communication ground	-	GND:Ground

Data direction 「→」 : from IFBOX to device

Data direction 「←」 : from device to IFBOX

⑤ IR output port: Use the supplied IR cable.

Indication	Name
+	Infrared light emitting diode anode side
-	Infrared light emitting diode cathode side

⑥ Ethernet port: 10Base-T/100Base-TX

Pin number	Abbreviation	Name	Data direction IFBOX – Device
1	TD+	Transmitted data	→
2	TD-	Transmitted data	→
3	RD+	Received data	←
4	NC		–
5	NC		–
6	RD-	Received data	←
7	NC		–
8	NC		–

Data direction 「→」 : from IFBOX to device

Data direction 「←」 : from device to IFBOX

Main unit specifications

Item	Description
Model	EBISS-IFBOX
Operating temperature/Humidity	0°C~40°C / 30%~80% (No condensation)
Power Source	DC12V (Supplied AC adapter AC100~240V)
Power consumption	9.6W
Control port	Serial port: RS-232C x3 (3-pin port x2 RX,TX,GND, 5-pin port x1 RX,TX,CTS,RTS,GND) Relay contact output x8 : Contact capacity (DC24V 1A) (8-pin port x1 [1,2,3,C][4,5,6,C], 2-pin port x2 [7,C][8,C]) Non-voltage contact input x4 8-pin port x1 IR signal output x1 2-pin port x1 IR learning x1 (built-in) Reset switch (for reset of the main unit) Reset switch (for reset of IP address)
Main unit control port	Ethernet x1 RJ45 connector 10Base-T/100Base-Tx
Outside dimensions	W: 208mm (8.19") D: 132mm (5.2") H: 27mm (1.06") (Excl. projecting parts)
Weight	Approx. 700 g (1.54lbs.)

■ Trademarks and Licenses

ELMO is a registered trademark of TECHNO HORIZON Co., Ltd.

Microsoft Edge is a registered trademark of Microsoft Corporation in the U.S. and other countries.

Google and Google Chrome are registered trademarks of Google LCC.

All other company and product names described in this manual are trademarks or registered trademarks of their respective companies.

Attention

Repair Parts

Repair parts are the items which are needed to maintain product functionality.

The holding period of such repair parts is 8 years after the product discontinuation, which is equal to the repair period we will accept.

TECHNO HORIZON CO., LTD.

2-13-1, Chikamatori, Minami-ku
Nagoya, 457-0071, Japan

OVERSEAS SUBSIDIARY COMPANIES

ELMO USA CORP.

Headquarters
1478 Old Country Road
Plainview, NY 11803, U.S.A.
Tel. (516) 501-1400 Fax.(516) 501-0429
E-mail: elmo@elmousa.com
Web: <http://www.elmousa.com>

ELMO Europe SAS

Headquarters
12 place de la Défense
Maison de la Défense
92974 Paris la Défense Cedex FRANCE
Tel. 33 (0) 1 73 02 67 06
Fax. 33 (0) 1 73 02 67 10
E-mail: info@elmoeurope.com
Web: <http://www.elmoeurope.com>

German Branch

Hansaallee 201, Haus 1
40549 Düsseldorf Germany
Tel. 49 (0) 211 544756 40
Fax. 49 (0) 211 544756 60

Middle East (Branch)

5WA-129, Dubai Airport Free Zone
P.O. Box 371556, Dubai
United Arab Emirates
TEL. +971-(0)4-260-2390
FAX. +971-(0)4-260-2392