

USER MANUAL

IN THE BOX

RGB Light	150 x Max 0.033X LED
Red Light	8-55 Lumens
Blue Light	4-10 Lumens
Green Light	20-30 Lumens
Main Material	UPC
Input	USA: DC 5V-1 A 1W
Light Source	RGB LEDs
Working Temperature	0-45°C
IP Rating	IP24 (For strip part only. Controller is not included)
Weight	190 g / 6.7 oz (including cable)
Length (Strip)	5 m / 16.4 ft
Length (Cable)	1.5 m / 4.9 ft
Operation Frequency (Controler Default)	2.4 GHz; 2402 MHz-2480 MHz
Maximum Output Power	2.4 GHz; 10 dBm
Control Distance	>25 m

Ostrip

Scan the QR code for the latest instruction.

CONTENTS

(E) English	01
(C) 中文	02
(F) Finnish	03
(N) Norwegian	04
(S) Swedish	06
(NL) Nederlands	07
(PL) Polska	09
(DE) Deutsch	10
(HU) Magyarországon	12
(RU) Русский	13
(ES) Español	15
(RO) Românească	16
(UK) Українська	17
(PT) Português	18
(KR) 한국어	21
(TH) ไทย	22
(FR) Français	23
(IT) Italiano	25
(SK) Slovensky	26
(PT) Português	28

ENGLISH

1. Please refer to Table 1 for product specifications.

2. Please refer to Figure 1 for the installation methods.

3. Please refer to Figure 2 for the installation methods.

4. Please refer to Figure 3 for the installation methods.

5. Please refer to Figure 4 for the installation methods.

6. Please refer to Figure 5 for the installation methods.

7. Please refer to Figure 6 for the installation methods.

8. Please refer to Figure 7 for the installation methods.

9. Please refer to Figure 8 for the installation methods.

10. Please refer to Figure 9 for the installation methods.

11. Please refer to Figure 10 for the installation methods.

12. Please refer to Figure 11 for the installation methods.

13. Please refer to Figure 12 for the installation methods.

14. Please refer to Figure 13 for the installation methods.

15. Please refer to Figure 14 for the installation methods.

16. Please refer to Figure 15 for the installation methods.

17. Please refer to Figure 16 for the installation methods.

18. Please refer to Figure 17 for the installation methods.

19. Please refer to Figure 18 for the installation methods.

20. Please refer to Figure 19 for the installation methods.

21. Please refer to Figure 20 for the installation methods.

22. Please refer to Figure 21 for the installation methods.

23. Please refer to Figure 22 for the installation methods.

24. Please refer to Figure 23 for the installation methods.

25. Please refer to Figure 24 for the installation methods.

26. Please refer to Figure 25 for the installation methods.

27. Please refer to Figure 26 for the installation methods.

28. Please refer to Figure 27 for the installation methods.

中文

1. 请参考表 1 了解产品规格。

2. 请参考图 1 了解安装方法。

3. 请参考图 2 了解安装方法。

4. 请参考图 3 了解安装方法。

5. 请参考图 4 了解安装方法。

6. 请参考图 5 了解安装方法。

7. 请参考图 6 了解安装方法。

8. 请参考图 7 了解安装方法。

9. 请参考图 8 了解安装方法。

10. 请参考图 9 了解安装方法。

11. 请参考图 10 了解安装方法。

12. 请参考图 11 了解安装方法。

13. 请参考图 12 了解安装方法。

14. 请参考图 13 了解安装方法。

15. 请参考图 14 了解安装方法。

16. 请参考图 15 了解安装方法。

17. 请参考图 16 了解安装方法。

18. 请参考图 17 了解安装方法。

19. 请参考图 18 了解安装方法。

20. 请参考图 19 了解安装方法。

21. 请参考图 20 了解安装方法。

22. 请参考图 21 了解安装方法。

23. 请参考图 22 了解安装方法。

24. 请参考图 23 了解安装方法。

25. 请参考图 24 了解安装方法。

26. 请参考图 25 了解安装方法。

27. 请参考图 26 了解安装方法。

28. 请参考图 27 了解安装方法。

1. Please refer to Table 1 for product specifications.

2. Please refer to Figure 1 for the installation methods.

3. Please refer to Figure 2 for the installation methods.

4. Please refer to Figure 3 for the installation methods.

5. Please refer to Figure 4 for the installation methods.

6. Please refer to Figure 5 for the installation methods.

7. Please refer to Figure 6 for the installation methods.

8. Please refer to Figure 7 for the installation methods.

9. Please refer to Figure 8 for the installation methods.

10. Please refer to Figure 9 for the installation methods.

11. Please refer to Figure 10 for the installation methods.

12. Please refer to Figure 11 for the installation methods.

13. Please refer to Figure 12 for the installation methods.

14. Please refer to Figure 13 for the installation methods.

15. Please refer to Figure 14 for the installation methods.

16. Please refer to Figure 15 for the installation methods.

17. Please refer to Figure 16 for the installation methods.

18. Please refer to Figure 17 for the installation methods.

19. Please refer to Figure 18 for the installation methods.

20. Please refer to Figure 19 for the installation methods.

21. Please refer to Figure 20 for the installation methods.

22. Please refer to Figure 21 for the installation methods.

23. Please refer to Figure 22 for the installation methods.

24. Please refer to Figure 23 for the installation methods.

25. Please refer to Figure 24 for the installation methods.

26. Please refer to Figure 25 for the installation methods.

27. Please refer to Figure 26 for the installation methods.

28. Please refer to Figure 27 for the installation methods.

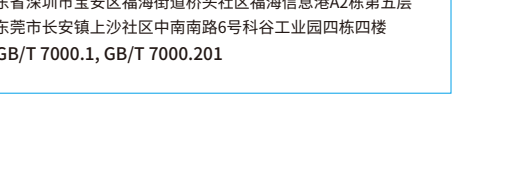
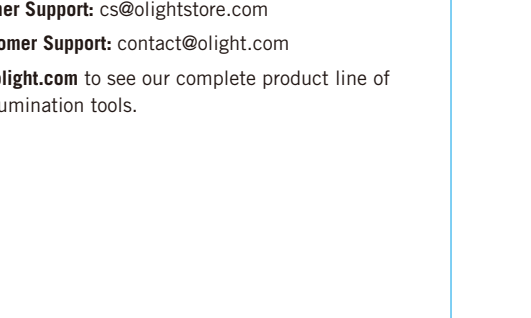
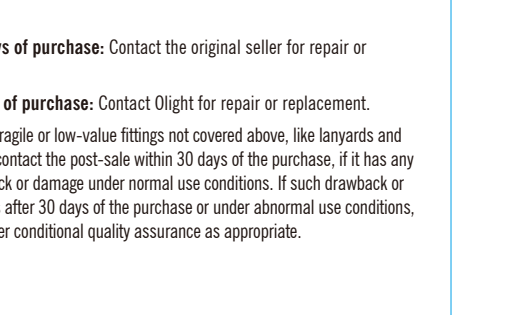
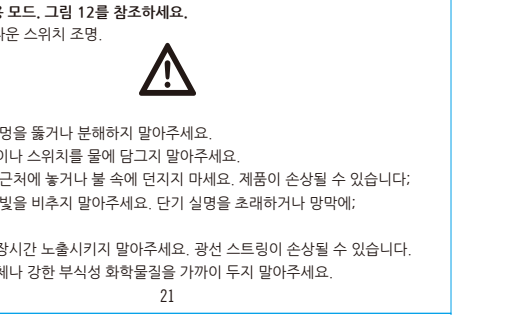
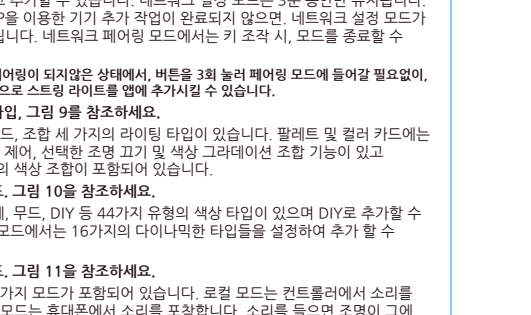
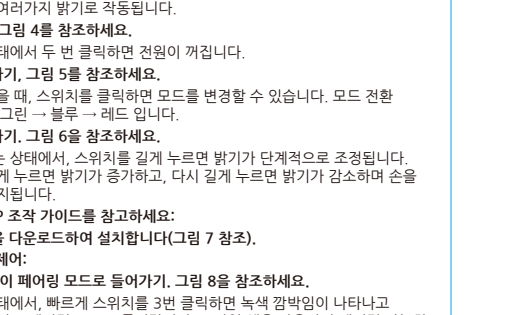
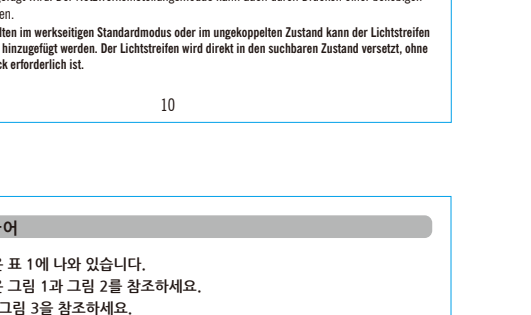
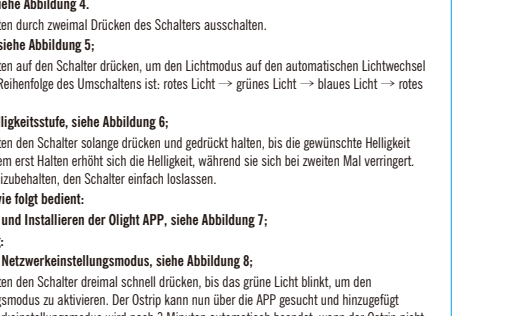
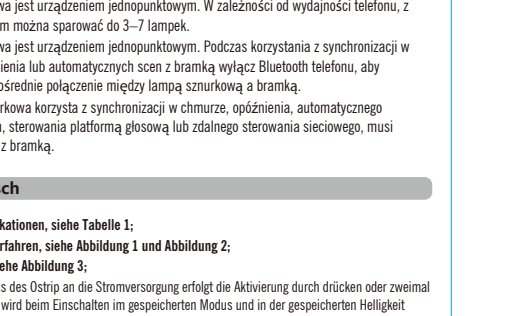
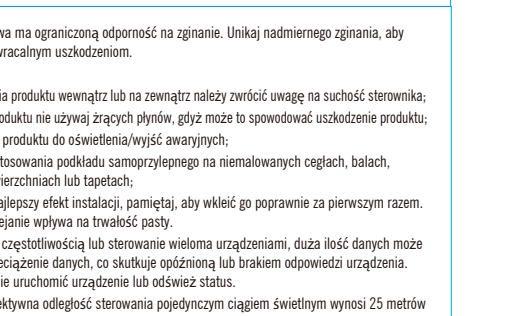
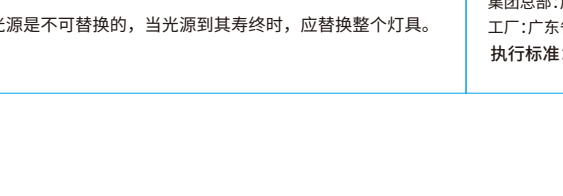
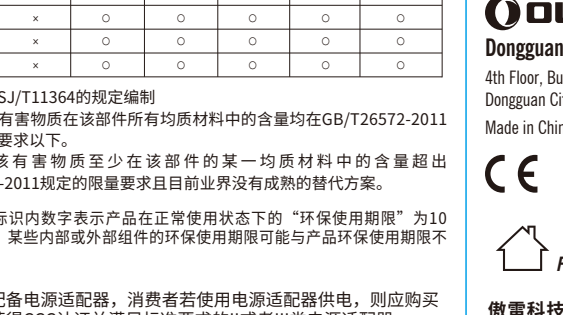
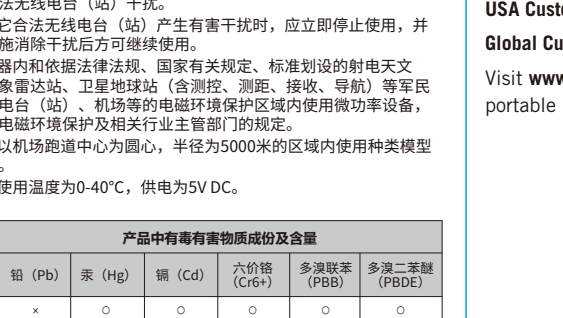
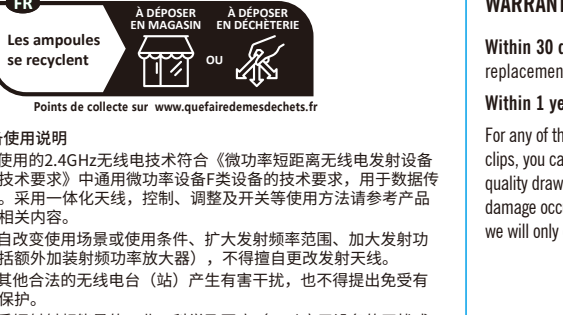
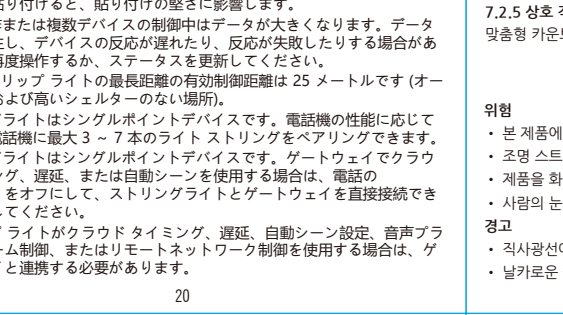
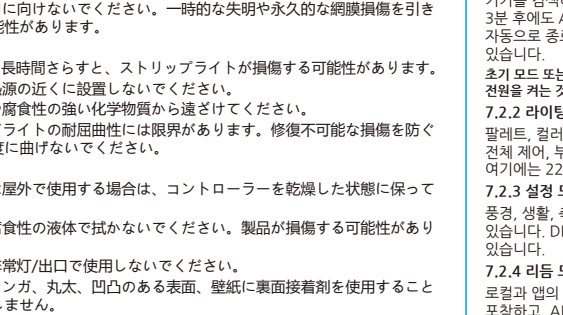
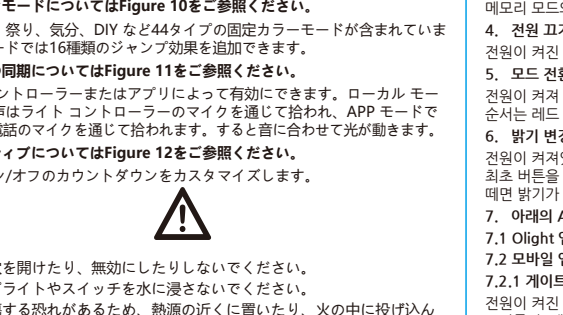
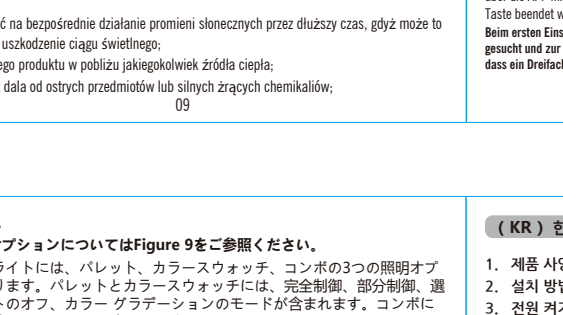
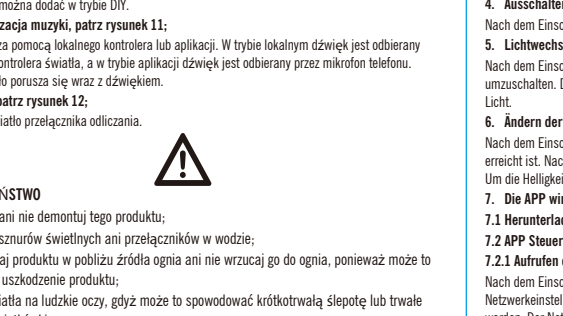
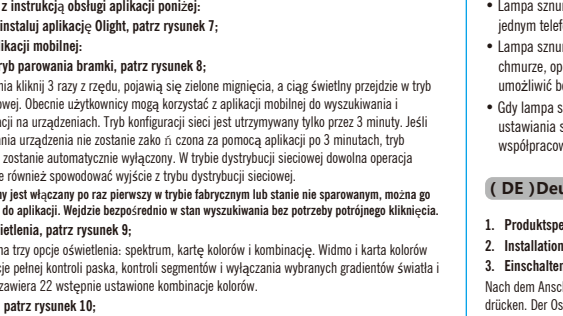
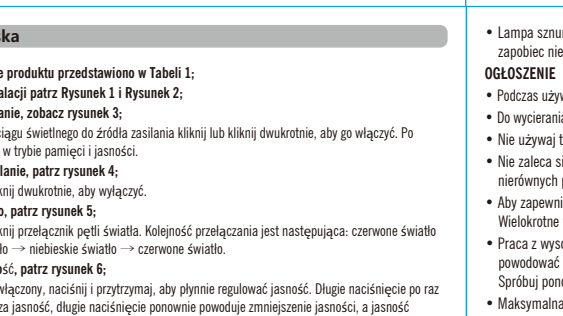
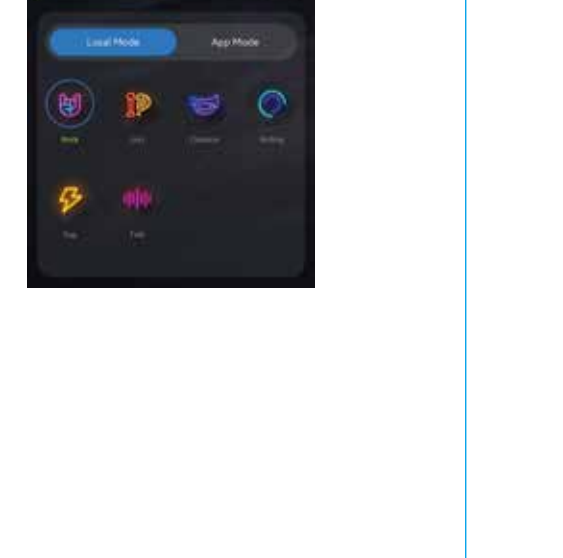
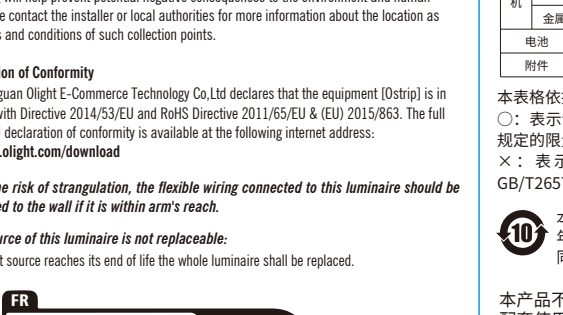
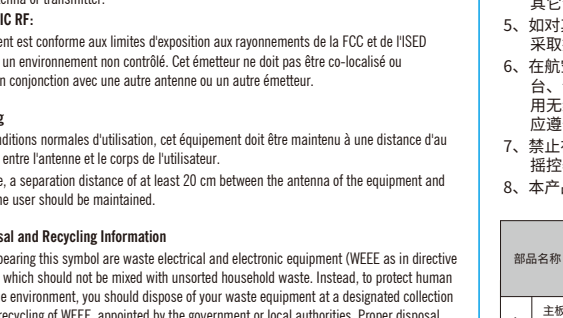
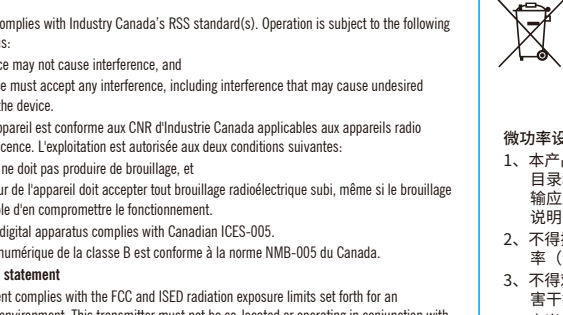
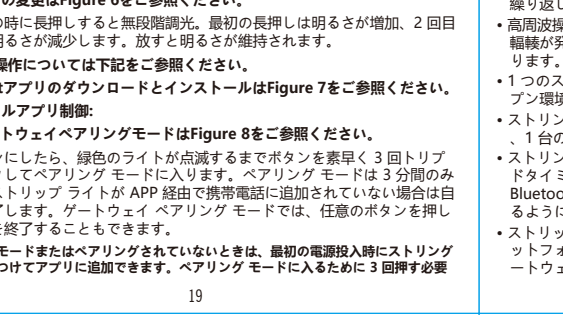
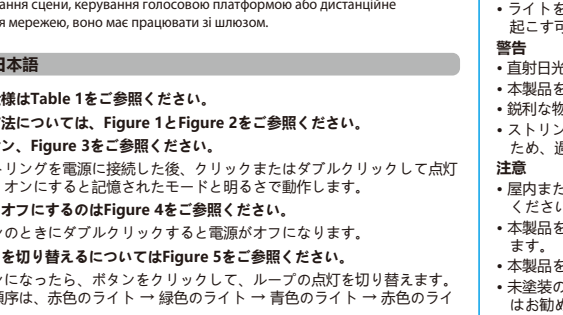
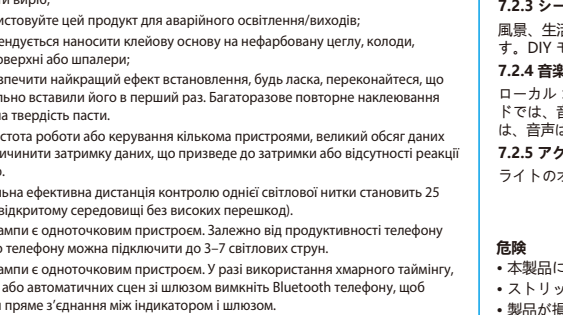
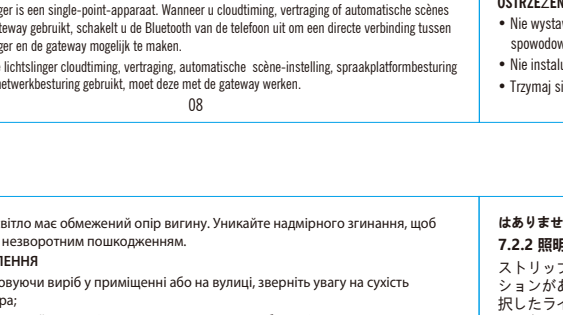
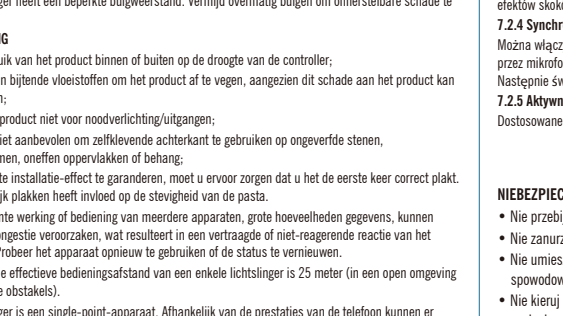
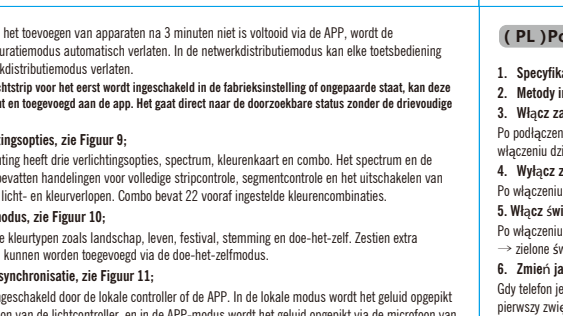
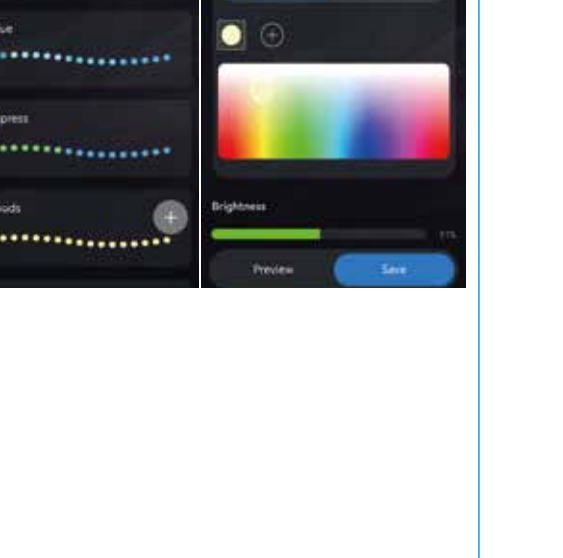
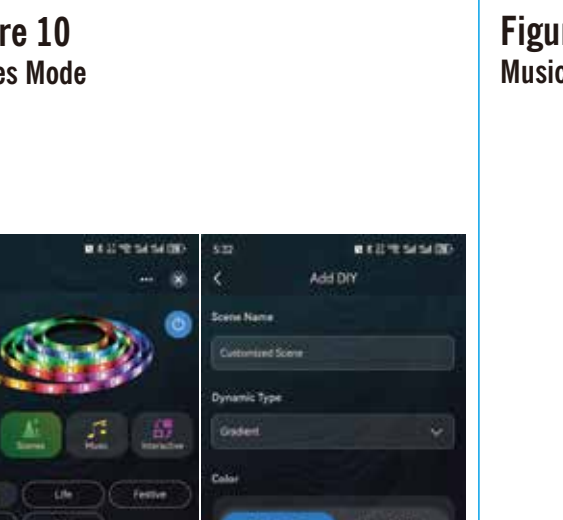
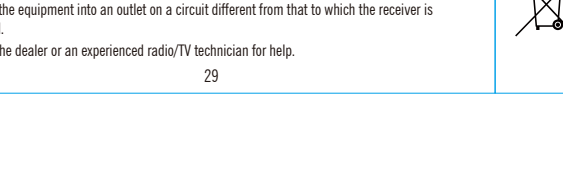
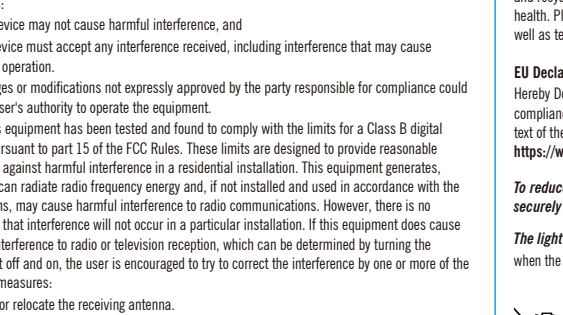
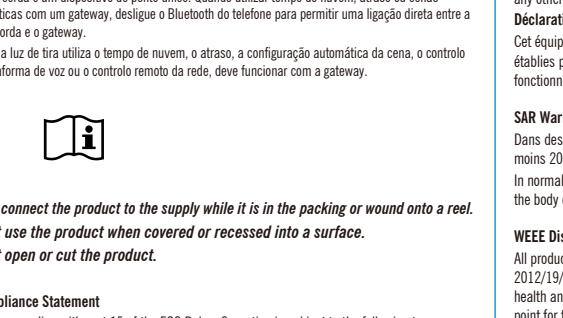
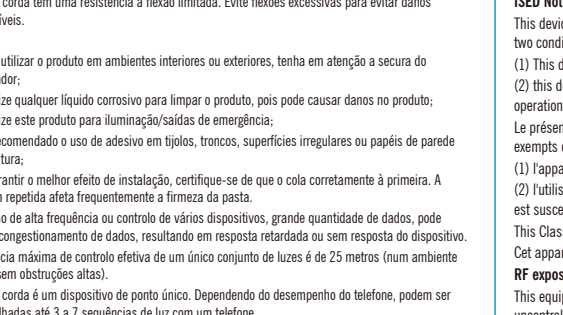
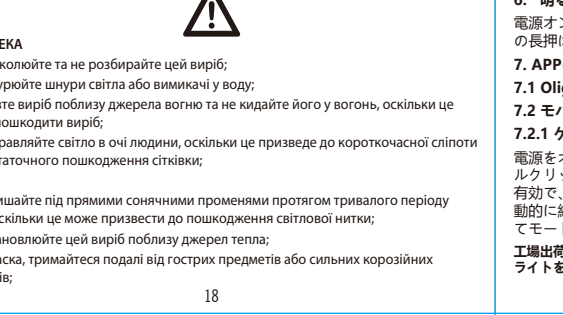
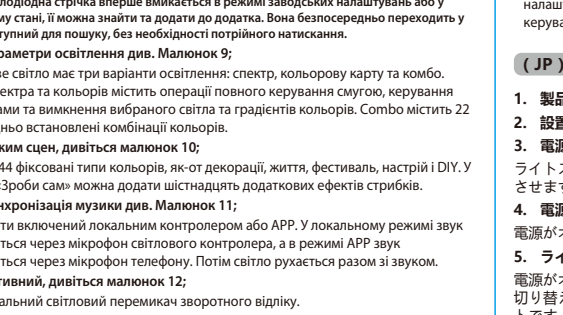
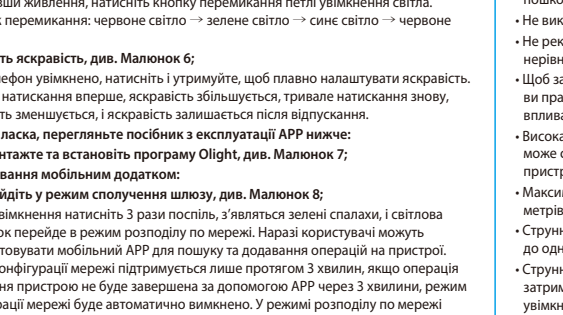
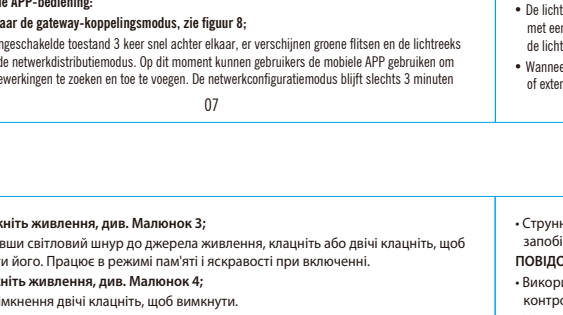
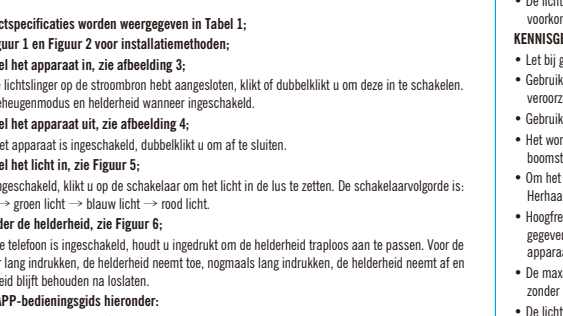
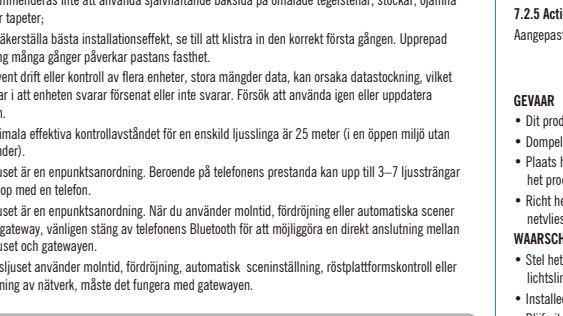
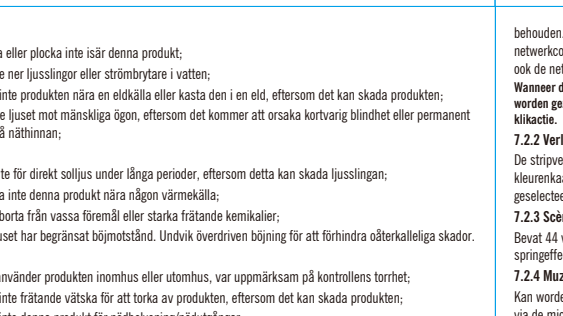
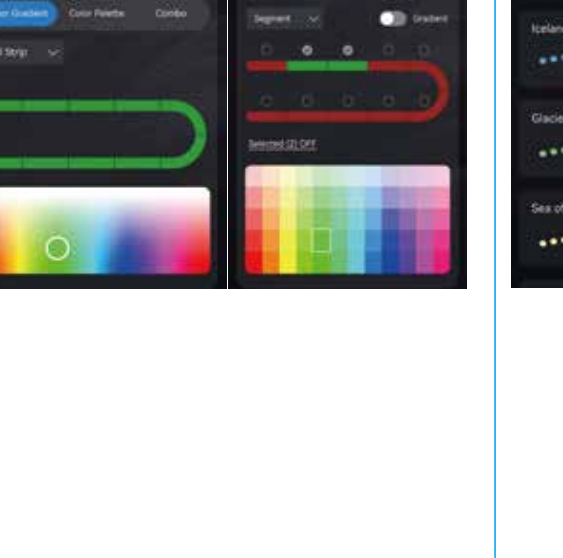
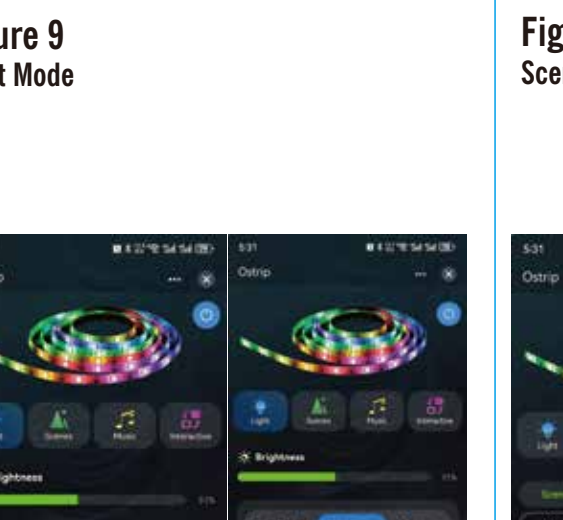
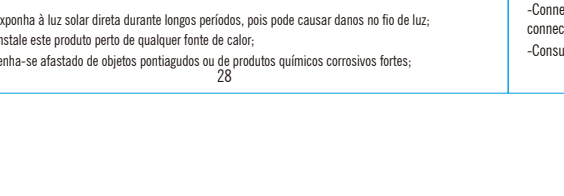
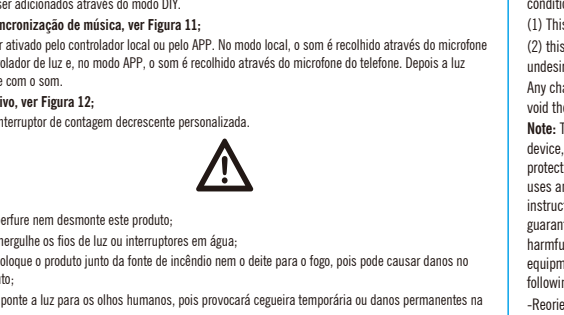
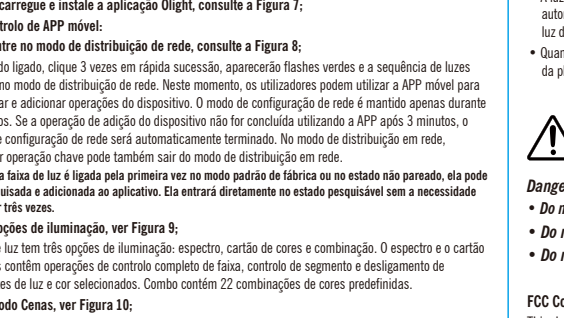
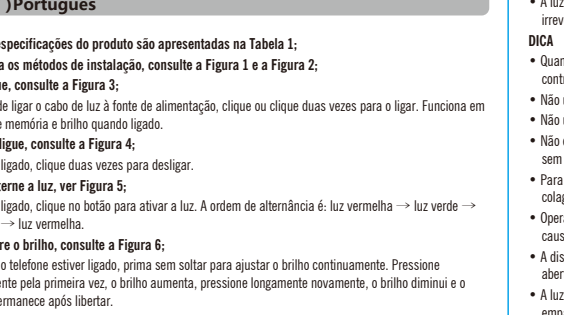
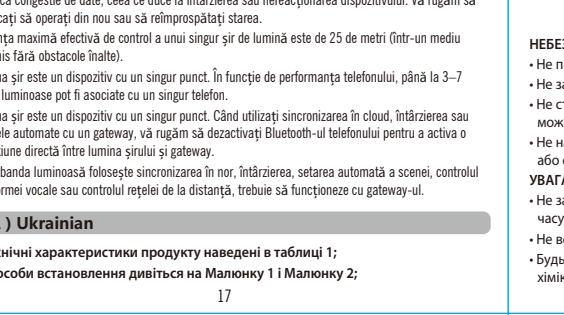
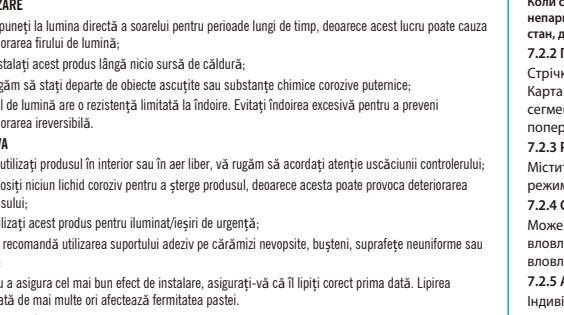
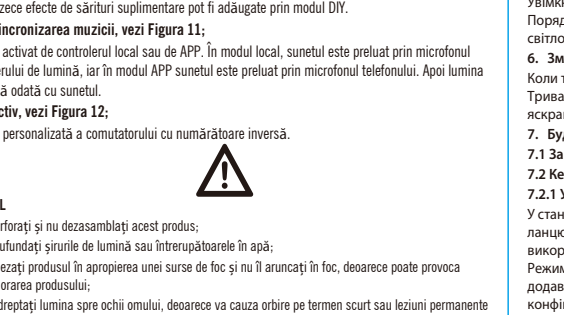
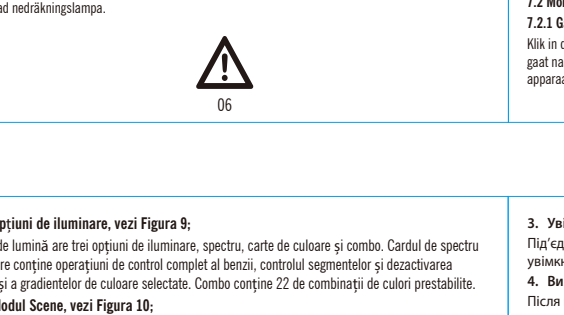
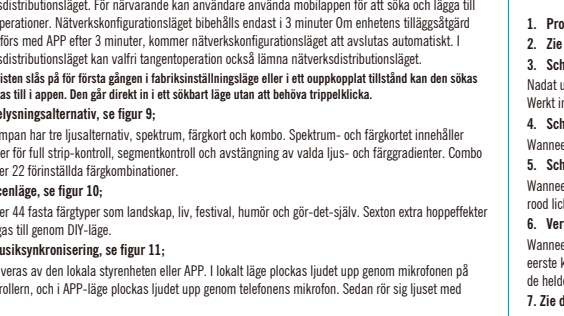
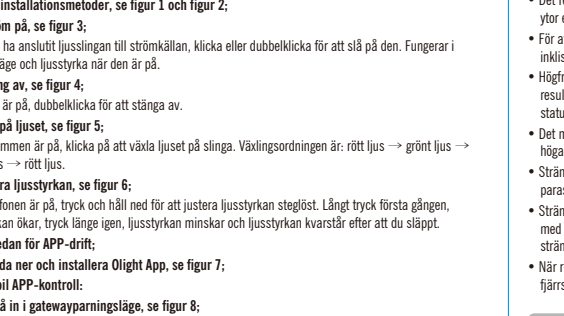
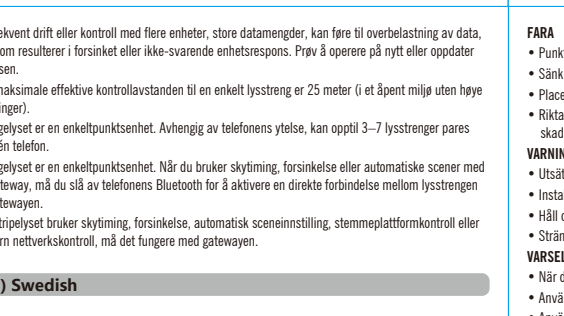
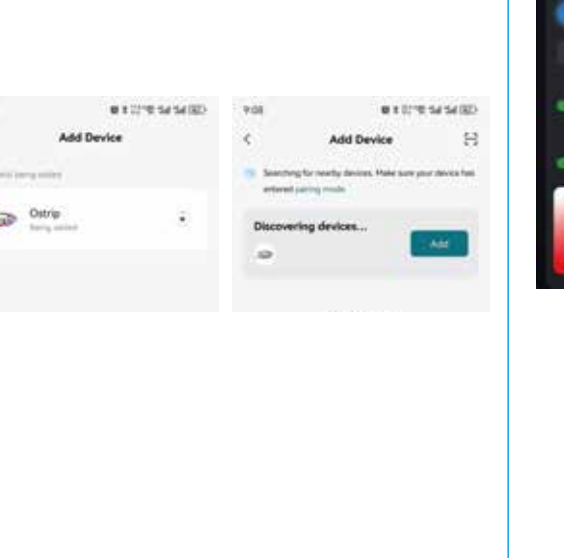
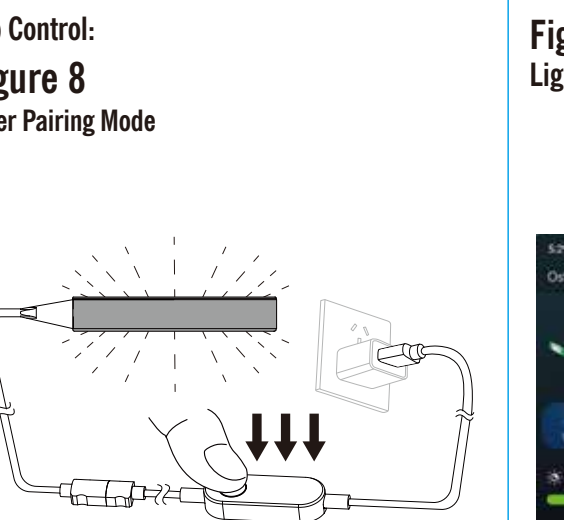
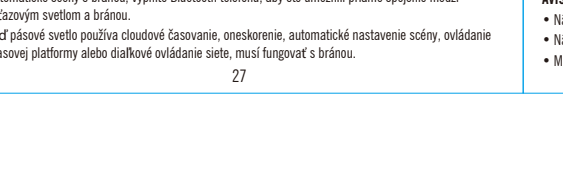
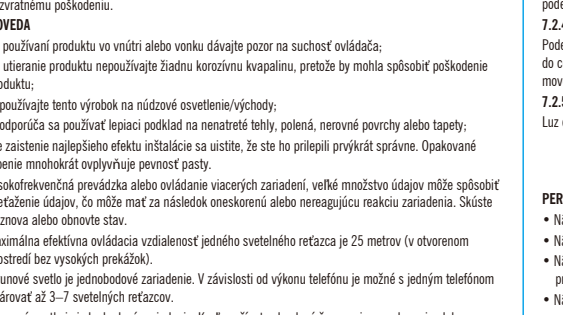
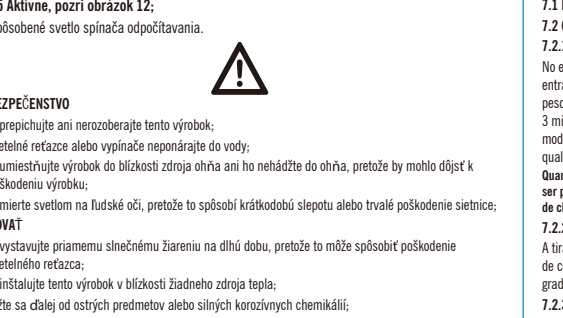
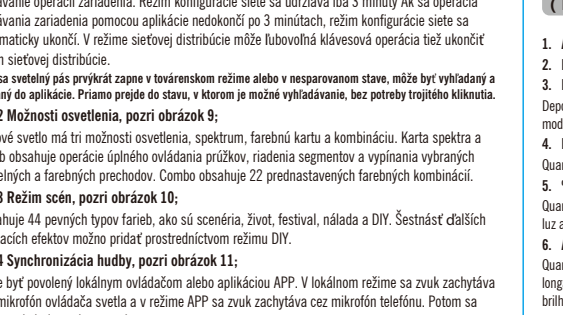
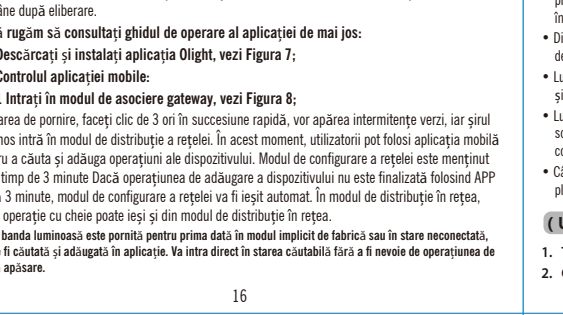
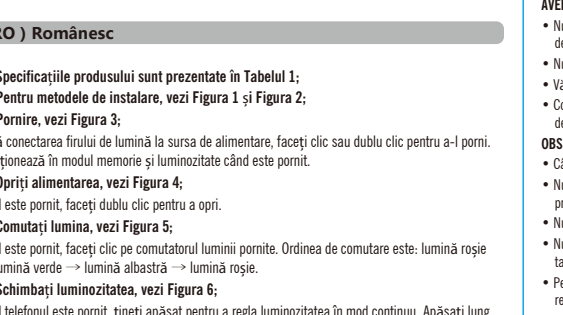
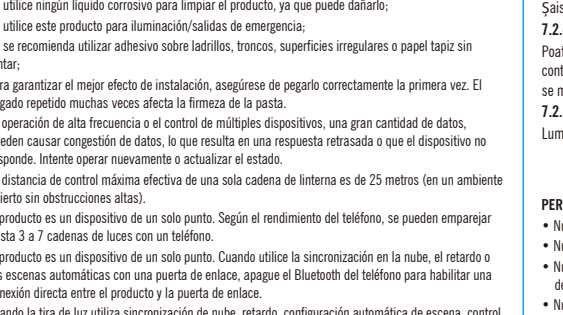
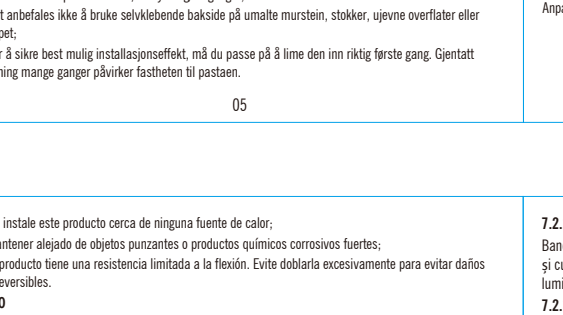
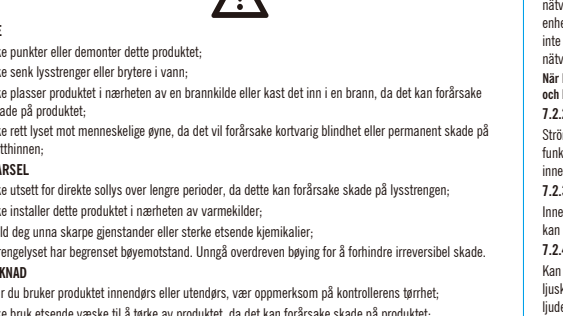
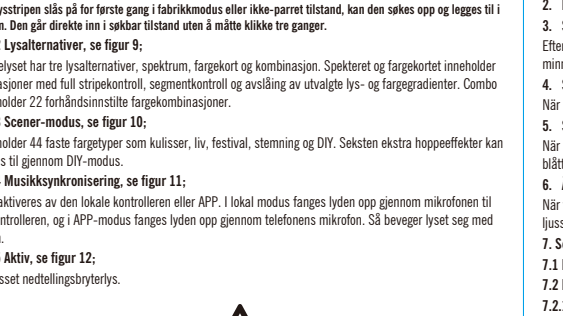
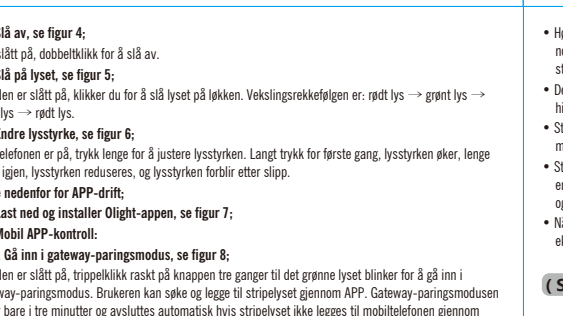
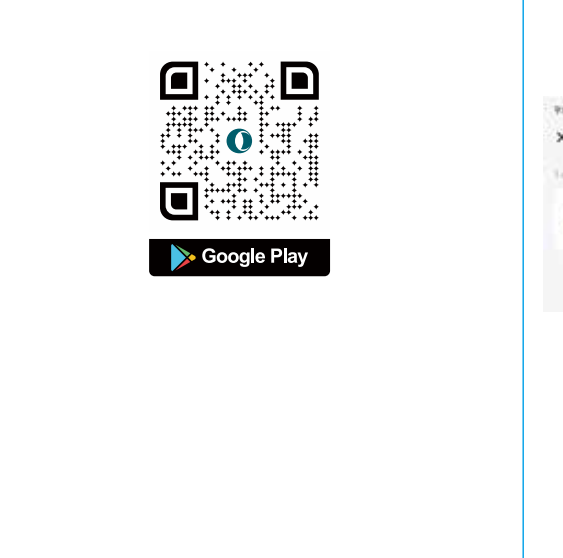
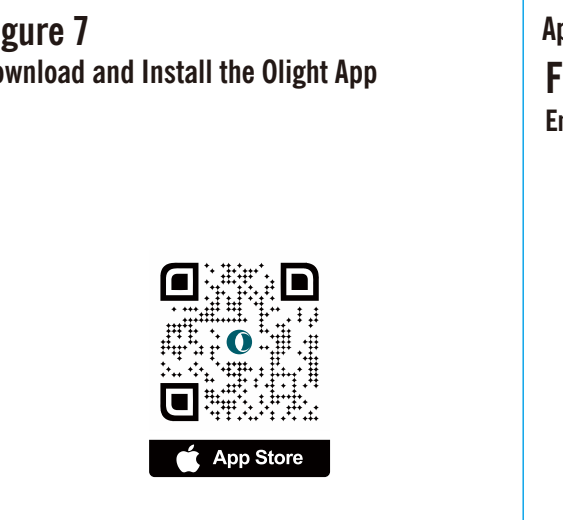
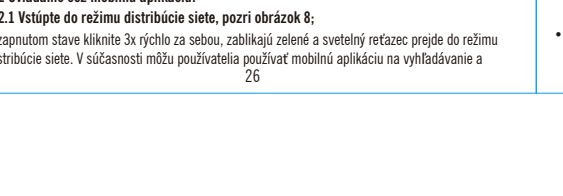
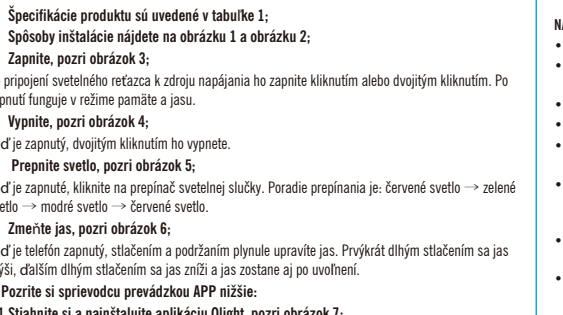
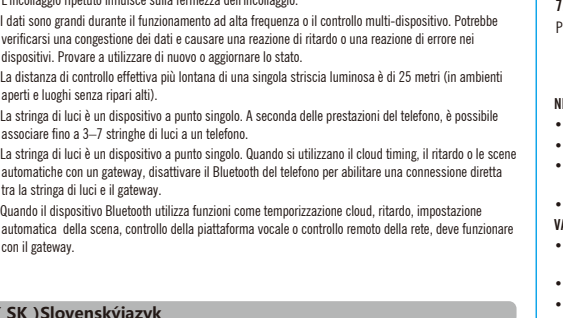
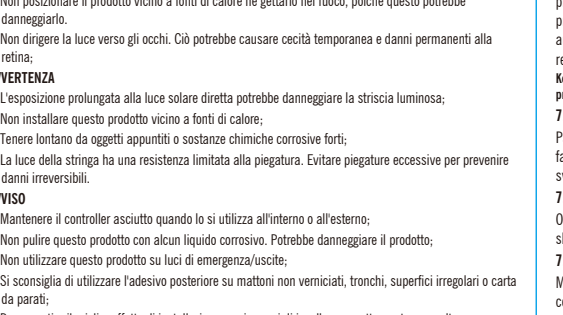
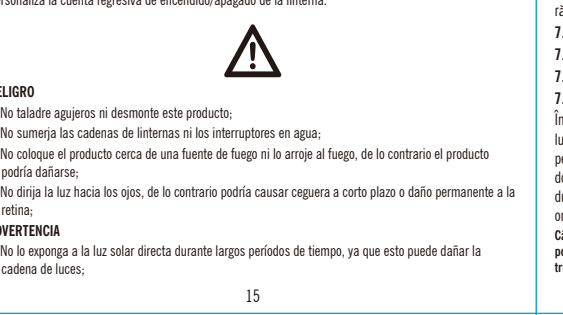
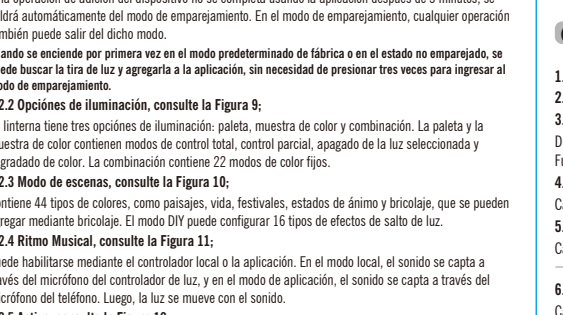
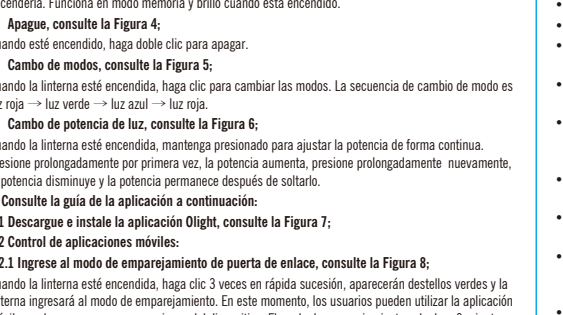
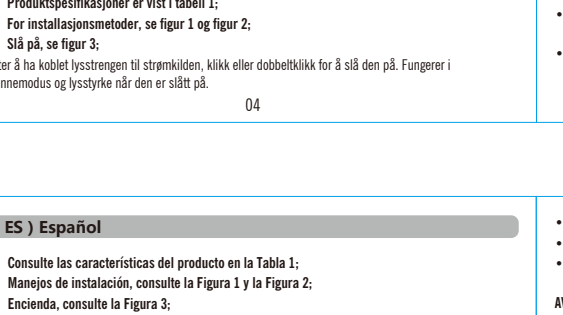
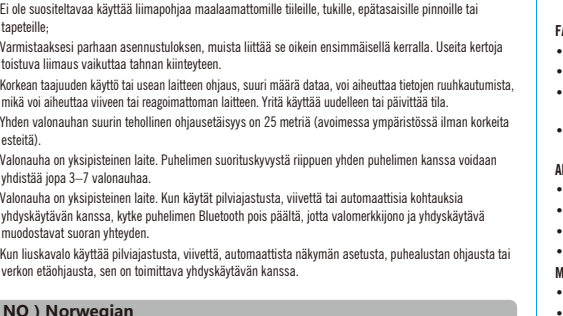
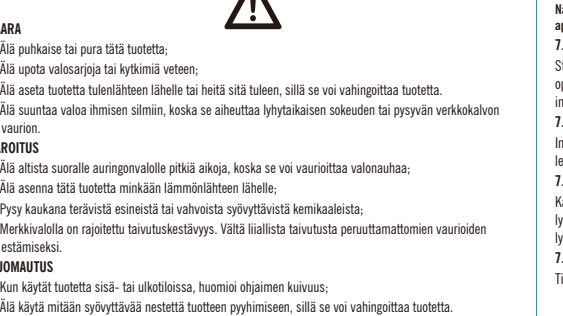
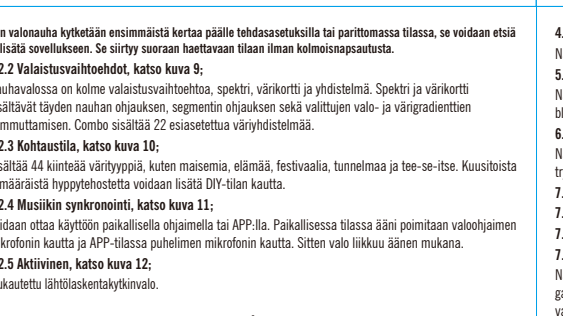
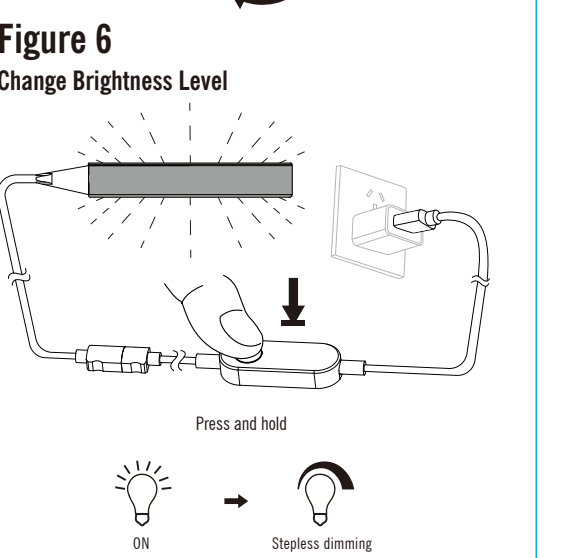
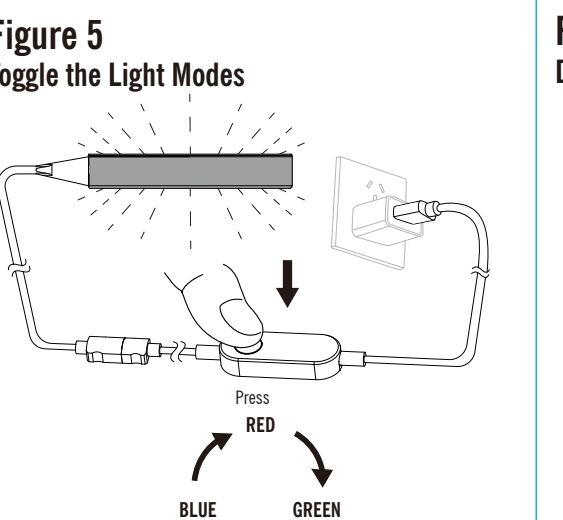
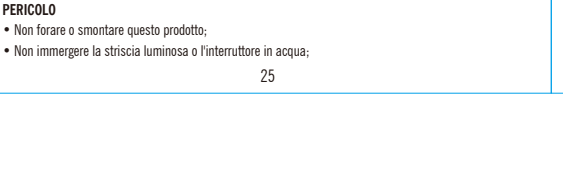
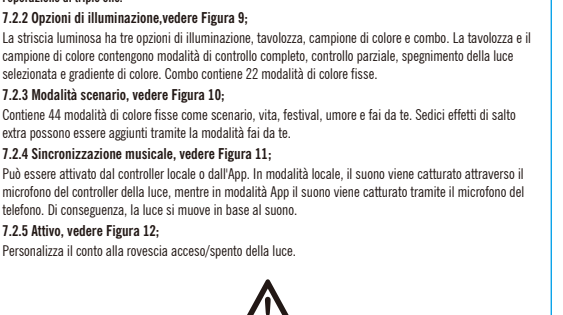
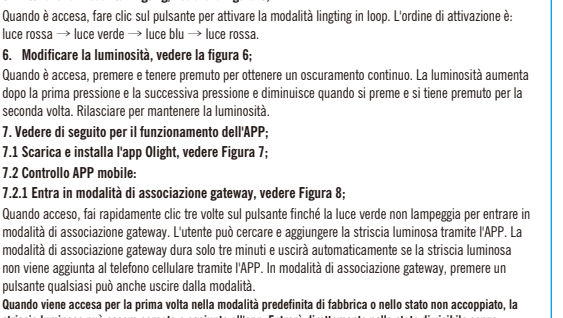
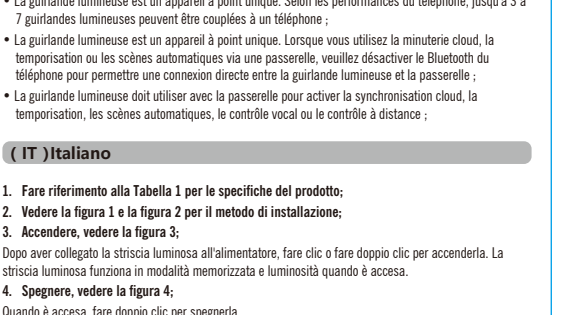
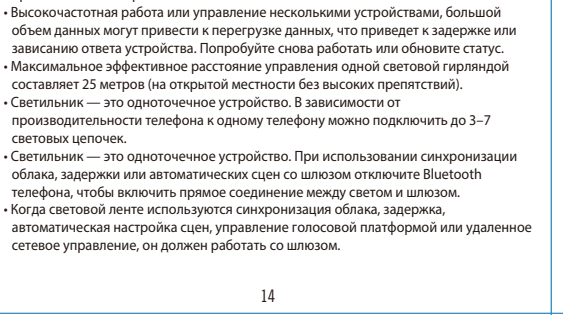
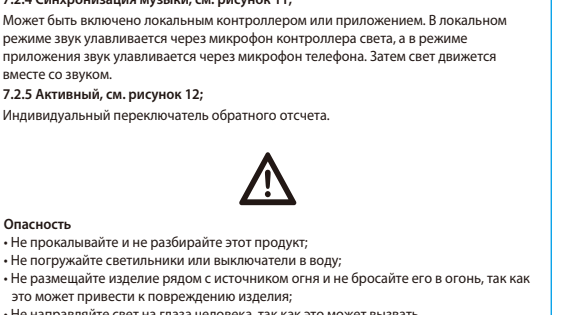
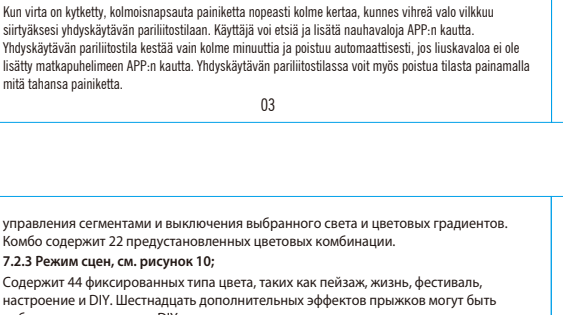
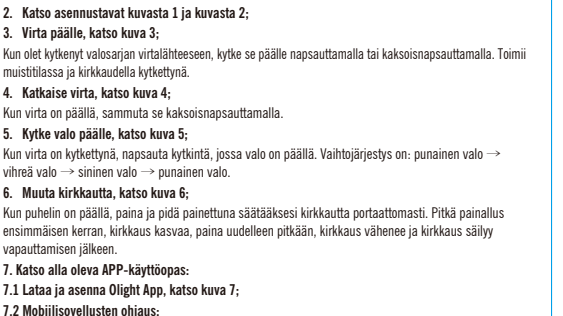
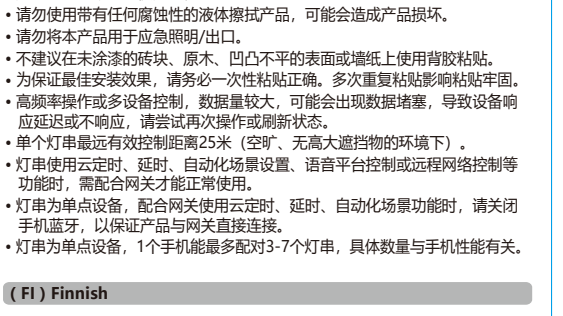
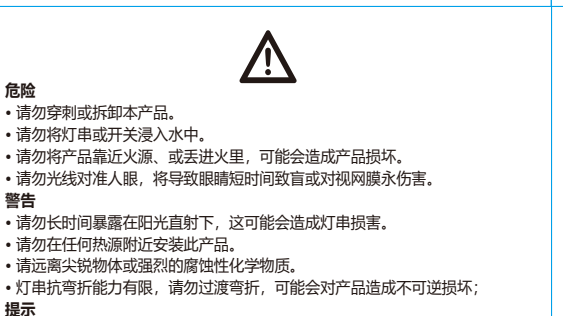
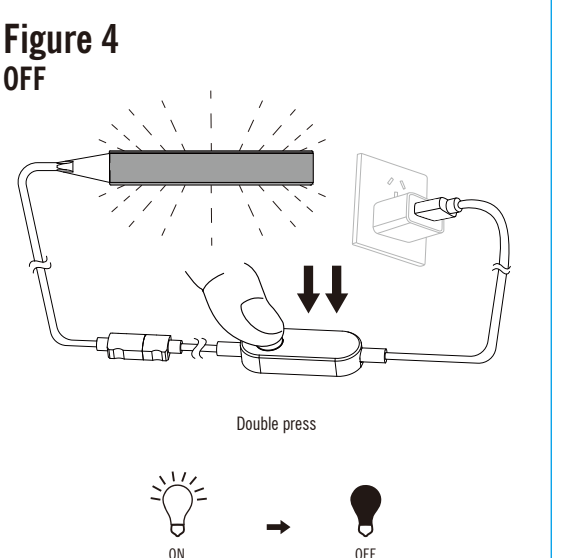
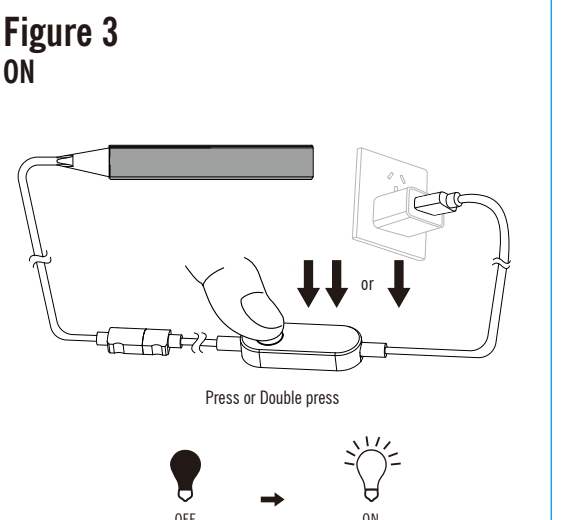
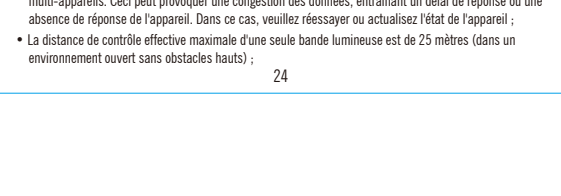
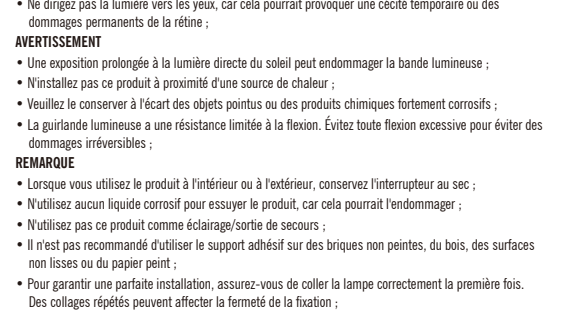
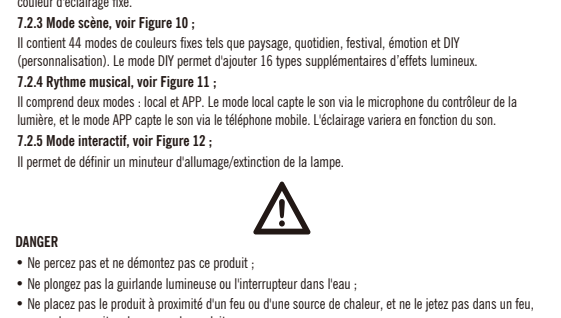
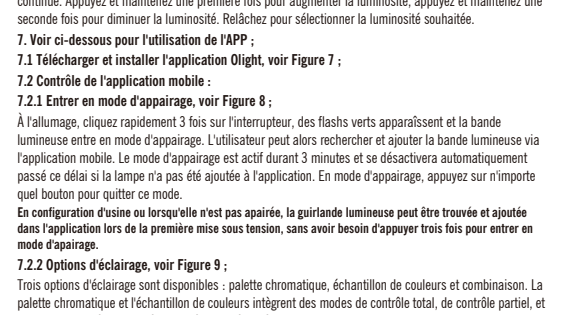
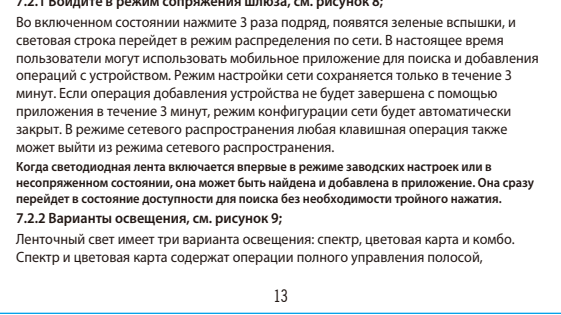
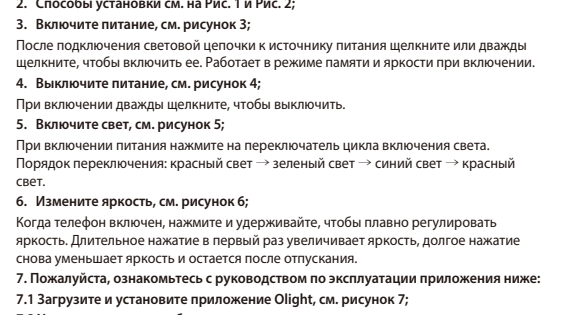
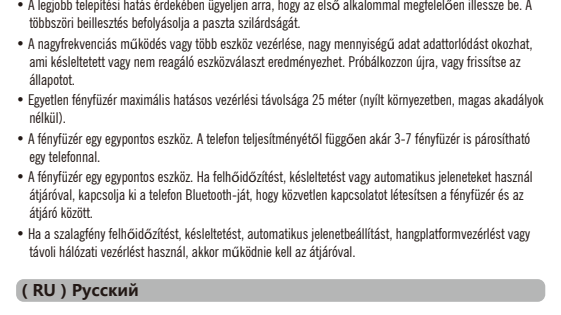
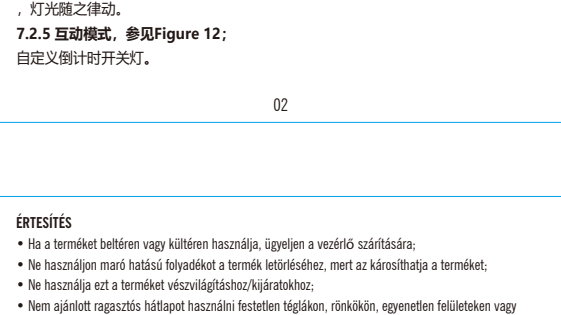
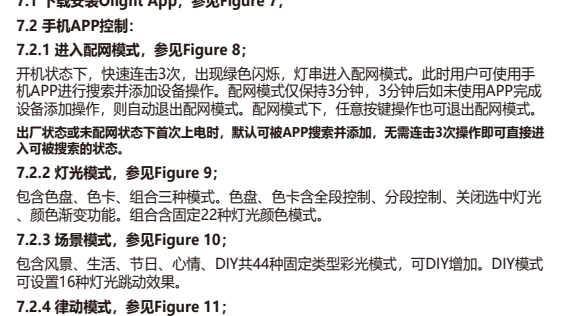
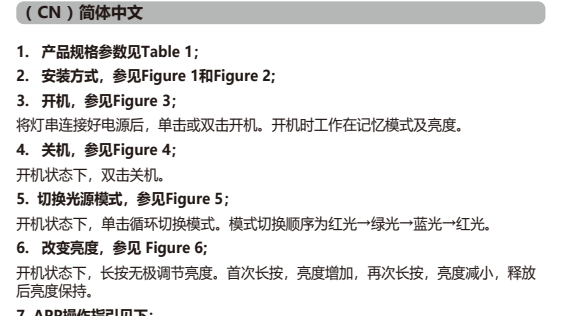
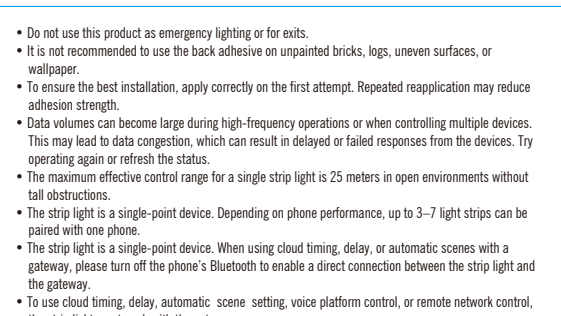
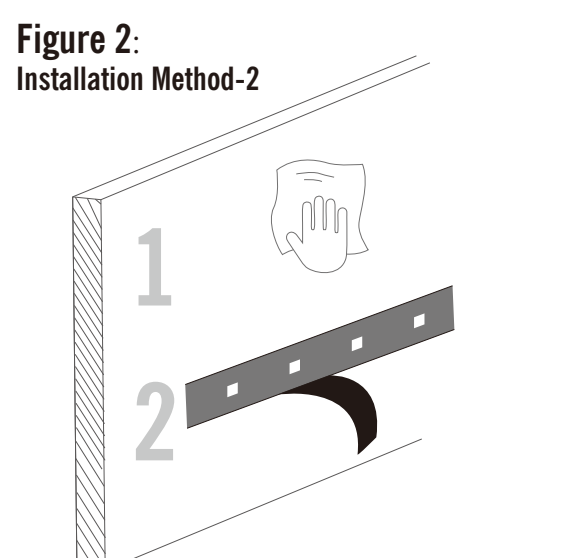
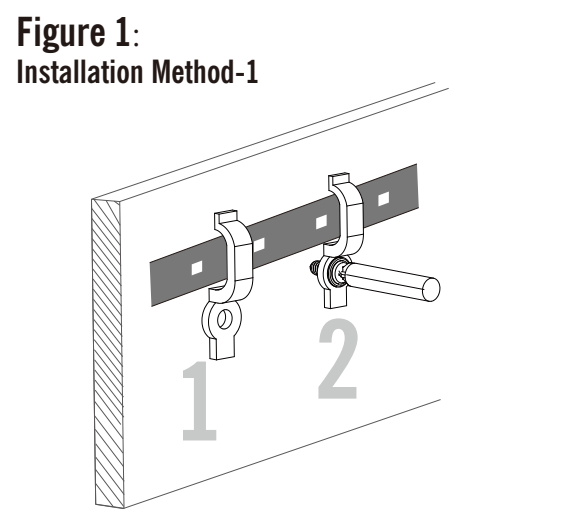

(E) English

1. Please refer to Table 1 for product specifications.

2. Please refer to Figure 1 for the installation methods.

3. Please refer to Figure 2 for the installation methods.

4. Please refer to Figure 3 for the installation methods.

5. Please refer to Figure 4 for the installation methods.

6. Please refer to Figure 5 for the installation methods.

7. Please refer to Figure 6 for the installation methods.

8. Please refer to Figure 7 for the installation methods.

9. Please refer to Figure 8 for the installation methods.

10. Please refer to Figure 9 for the installation methods.

11. Please refer to Figure 10 for the installation methods.

12. Please refer to Figure 11 for the installation methods.

13. Please refer to Figure 12 for the installation methods.

14. Please refer to Figure 13 for the installation methods.

15. Please refer to Figure 14 for the installation methods.

16. Please refer to Figure 15 for the installation methods.

17. Please refer to Figure 16 for the installation methods.

18. Please refer to Figure 17 for the installation methods.

19. Please refer to Figure 18 for the installation methods.

20. Please refer to Figure 19 for the installation methods.

21. Please refer to Figure 20 for the installation methods.

22. Please refer to Figure 21 for the installation methods.

23. Please refer to Figure 22 for the installation methods.

24. Please refer to Figure 23 for the installation methods.

25. Please refer to Figure 24 for the installation methods.

26. Please refer to Figure 25 for the installation methods.

27. Please refer to Figure 26 for the installation methods.

28. Please refer to Figure 27 for the installation methods.

(C) 中文

1. 请参考表 1 了解产品规格。

2. 请参考图 1 了解安装方法。

3. 请参考图 2 了解安装方法。

4. 请参考图 3 了解安装方法。

5. 请参考图 4 了解安装方法。

6. 请参考图 5 了解安装方法。

7. 请参考图 6 了解安装方法。

8. 请参考图 7 了解安装方法。

9. 请参考图 8 了解安装方法。

10. 请参考图 9 了解安装方法。

11. 请参考图 10 了解安装方法。

12. 请参考图 11 了解安装方法。

13. 请参考图 12 了解安装方法。

14. 请参考图 13 了解安装方法。

15. 请参考图 14 了解安装方法。

16. 请参考图 15 了解安装方法。

17. 请参考图 16 了解安装方法。

18. 请参考图 17 了解安装方法。

19. 请参考图 18 了解安装方法。

20. 请参考图 19 了解安装方法。

21. 请参考图 20 了解安装方法。

22. 请参考图 21 了解安装方法。

23. 请参考图 22 了解安装方法。

24. 请参考图 23 了解安装方法。

25. 请参考图 24 了解安装方法。

26. 请参考图 25 了解安装方法。

27. 请参考图 26 了解安装方法。

28. 请参考图 27 了解安装方法。

(F) Finnish

1. Tarkastele taulukko 1:tä tuotteen tekniset tiedot varten.

2. Katso kuvaa 1:tä tuotteen asennusmenetelmien varten.

3. Katso kuvaa 2:tä tuotteen asennusmenetelmien varten.

4. Katso kuvaa 3:tä tuotteen asennusmenetelmien varten.

5. Katso kuvaa 4:tä tuotteen asennusmenetelmien varten.

6. Katso kuvaa 5:tä tuotteen asennusmenetelmien varten.

7. Katso kuvaa 6:tä tuotteen asennusmenetelmien varten.

8. Katso kuvaa 7:tä tuotteen asennusmenetelmien varten.

9. Katso kuvaa 8:tä tuotteen asennusmenetelmien varten.

10. Katso kuvaa 9:tä tuotteen asennusmenetelmien varten.

11. Katso kuvaa 10:tä tuotteen asennusmenetelmien varten.

12. Katso kuvaa 11:tä tuotteen asennusmenetelmien varten.

13. Katso kuvaa 12:tä tuotteen asennusmenetelmien varten.

14. Katso kuvaa 13:tä tuotteen asennusmenetelmien varten.

15. Katso kuvaa 14:tä tuotteen asennusmenetelmien varten.

16. Katso kuvaa 15:tä tuotteen asennusmenetelmien varten.

17. Katso kuvaa 16:tä tuotteen asennusmenetelmien varten.

18. Katso kuvaa 17:tä tuotteen asennusmenetelmien varten.

19. Katso kuvaa 18:tä tuotteen asennusmenetelmien varten.

20. Katso kuvaa 19:tä tuotteen asennusmenetelmien varten.

21. Katso kuvaa 20:tä tuotteen asennusmenetelmien varten.

22. Katso kuvaa 21:tä tuotteen asennusmenetelmien varten.

23. Katso kuvaa 22:tä tuotteen asennusmenetelmien varten.

24. Katso kuvaa 23:tä tuotteen asennusmenetelmien varten.

25. Katso kuvaa 24:tä tuotteen asennusmenetelmien varten.

26. Katso kuvaa 25:tä tuotteen asennusmenetelmien varten.

27. Katso kuvaa 26:tä tuotteen asennusmenetelmien varten.

28. Katso kuvaa 27:tä tuotteen asennusmenetelmien varten.

(N) Norwegian

1. Se tabell 1 for produktspesifikasjoner.

2. Se figur 1 for installasjonsmetoder.

3. Se figur 2 for installasjonsmetoder.

4. Se figur 3 for installasjonsmetoder.

5. Se figur 4 for installasjonsmetoder.

6. Se figur 5 for installasjonsmetoder.

7. Se figur 6 for installasjonsmetoder.

8. Se figur 7 for installasjonsmetoder.

9. Se figur 8 for installasjonsmetoder.

10. Se figur 9 for installasjonsmetoder.

11. Se figur 10 for installasjonsmetoder.

12. Se figur 11 for installasjonsmetoder.

13. Se figur 12 for installasjonsmetoder.

14. Se figur 13 for installasjonsmetoder.

15. Se figur 14 for installasjonsmetoder.

16. Se figur 15 for installasjonsmetoder.

17. Se figur 16 for installasjonsmetoder.

18. Se figur 17 for installasjonsmetoder.

19. Se figur 18 for installasjonsmetoder.

20. Se figur 19 for installasjonsmetoder.

21. Se figur 20 for installasjonsmetoder.

22. Se figur 21 for installasjonsmetoder.

23. Se figur 22 for installasjonsmetoder.

24. Se figur 23 for installasjonsmetoder.

25. Se figur 24 for installasjonsmetoder.

26. Se figur 25 for installasjonsmetoder.

27. Se figur 26 for installasjonsmetoder.

28. Se figur 27 for installasjonsmetoder.

(S) Swedish

1. Se tabell 1 för produktspesifikationer.

2. Se figur 1 för installationsmetoder.

3. Se figur 2 för installationsmetoder.

4. Se figur 3 för installationsmetoder.

5. Se figur 4 för installationsmetoder.

6. Se figur 5 för installationsmetoder.

7. Se figur 6 för installationsmetoder.

8. Se figur 7 för installationsmetoder.

9. Se figur 8 för installationsmetoder.

10. Se figur 9 för installationsmetoder.

11. Se figur 10 för installationsmetoder.

12. Se figur 11 för installationsmetoder.

13. Se figur 12 för installationsmetoder.

14. Se figur 13 för installationsmetoder.

15. Se figur 14 för installationsmetoder.

16. Se figur 15 för installationsmetoder.

17. Se figur 16 för installationsmetoder.

18. Se figur 17 för installationsmetoder.

19. Se figur 18 för installationsmetoder.

20. Se figur 19 för installationsmetoder.

21. Se figur 20 för installationsmetoder.

22. Se figur 21 för installationsmetoder.

23. Se figur 22 för installationsmetoder.

24. Se figur 23 för installationsmetoder.

25. Se figur 24 för installationsmetoder.

26. Se figur 25 för installationsmetoder.

27. Se figur 26 för installationsmetoder.

28. Se figur 27 för installationsmetoder.

(NL) Nederlands

1. Zie tabel 1 voor de productspecificaties.

2. Zie figuur 1 voor de installatiemethodes.

3. Zie figuur 2 voor de installatiemethodes.

4. Zie figuur 3 voor de installatiemethodes.

5. Zie figuur 4 voor de installatiemethodes.

6. Zie figuur 5 voor de installatiemethodes.

7. Zie figuur 6 voor de installatiemethodes.

8. Zie figuur 7 voor de installatiemethodes.

9. Zie figuur 8 voor de installatiemethodes.

10. Zie figuur 9 voor de installatiemethodes.

11. Zie figuur 10 voor de installatiemethodes.

12. Zie figuur 11 voor de installatiemethodes.

13. Zie figuur 12 voor de installatiemethodes.

14. Zie figuur 13 voor de installatiemethodes.

15. Zie figuur 14 voor de installatiemethodes.

16. Zie figuur 15 voor de installatiemethodes.

17. Zie figuur 16 voor de installatiemethodes.

18. Zie figuur 17 voor de installatiemethodes.

19. Zie figuur 18 voor de installatiemethod