

USER GUIDE • GUIDE DE L'UTILISATEUR



**BlueSYNC® STW**



REGISTER NOW

ENREGISTRER

*This product comes with a 1 year limited warranty.*

**Register this product within 30 days of sale to activate a complimentary 2 year warranty extension and receive free advanced technical support. Learn more and register now.**

*Ce produit a une garantie limitée de 1 an.*

**Enregistrez ce produit dans les 30 jours suivant son achat pour activer l'extension de garantie de 2 ans et bénéficier de notre service après-vente gratuit. Pour en savoir plus, enregistrez ce produit dès à présent.**

**[G0groove.com/warranty](http://G0groove.com/warranty)**

# BECOME A VIP



## WHY SHOULD I JOIN?

- Free Product Giveaways
- Exclusive Discounts
- Sneak Peek at New Products
- And More VIP Perks!

## JOIN THE CLUB TODAY

[AccessoryPower.com/VIPclub](http://AccessoryPower.com/VIPclub)

# IN LESS THAN 30 SECONDS



**Need help with this product?  
Besoin d'assistance sur ce produit?  
¿Necesita ayuda con este producto?  
Benötigen Sie Hilfe bei diesem Produkt?  
Hai bisogno di aiuto per questo prodotto?  
购买的产品，是否需要提供协助？**

**[G0groove.com/support](https://G0groove.com/support)**

# SAFETY AND PRODUCT INFORMATION

## SÉCURITÉ ET INFORMATIONS DU PRODUIT

---

### **Safety information:**

Before using this GÓgroove product, review these safety and regulatory information provided in this document. Keep this document in a safe place so that you can refer to it whenever you need it.

### **Important safety precautions:**

- 1) Read these instructions.
- 2) Keep these instructions.
- 3) Heed all warnings.
- 4) Follow all instructions.
- 5) Do not use this product near water.
- 6) Clean only with a dry cloth.
- 7) Do not block any ventilation openings. Install in accordance with the manufacturer's instructions.
- 8) Do not install near any heat sources such as radiators, heat registers, stoves or other apparatus (including amplifiers) that produce heat.
- 9) Protect the power cord from being walked on or pinched particularly at plugs, convenience receptacles, and the point where they exit from the product.
- 10) Only use attachments/accessories specified by the manufacturer.
- 11) Use only with the cart, stand, tripod, bracket, or table specified by the manufacturer, or sold with the product.
- 12) Unplug the product during lightning storms or when unused for long periods of time.
- 13) Refer all servicing to qualified service personnel. Servicing is required when the apparatus has been damaged in any way, such as power-supply cord or plug is damaged, liquid has been spilled or objects have fallen into the product, the product has been exposed to rain or moisture, does not operate normally, or has been dropped.
- 14) No naked flame sources, such as lighted candles, should be placed on the product.

### **Information de sécurité:**

Avant d'utiliser ce produit GÓgroove, consultez les informations sur la sécurité et la réglementation fournies dans ce document. Gardez ce document dans un endroit sûr afin que vous puissiez vous y référer chaque fois que vous en avez besoin.

### **Mesures de sécurité importantes :**

- 1) Lisez ces instructions.
- 2) Conservez ces instructions.
- 3) Respectez tous les avertissements.
- 4) Suivez toutes les instructions.
- 5) N'utilisez pas ce produit près de l'eau.
- 6) Nettoyez uniquement avec un chiffon sec.
- 7) Ne bloquez pas les ouvertures de ventilation. Installez conformément aux instructions du fabricant.
- 8) Ne pas installer à proximité de sources de chaleur telles que des radiateurs, des bouches de chaleur, des poêles ou d'autres appareils (y compris les amplificateurs) produisant de la chaleur.
- 9) Protégez le cordon d'alimentation de tout piétinement ou pincement, en particulier au niveau des connecteurs, des prises de courant et du point de sortie du produit.
- 10) Utilisez uniquement les connexions/accessoires spécifiés par le fabricant.
- 11) Utilisez uniquement avec le chariot, le support, le trépied, le support ou la table spécifié par le fabricant ou vendu avec le produit.
- 12) Débranchez le produit pendant les orages ou lorsqu'il n'est pas utilisé pendant de longues périodes.
- 13) Confiez toute réparation à un technicien qualifié. Un entretien est nécessaire lorsque l'appareil a été endommagé de quelque façon que ce soit, par exemple un cordon d'alimentation ou une prise endommagée, si du liquide a été renversé ou des objets sont tombés dans le produit, si le produit a été exposé à la pluie ou à l'humidité ou a été abandonné.
- 14) Aucune source de flamme nue, telle qu'une bougie allumée, ne doit être placée sur le produit.

**Package contents**  
**L'emballage contient**  
**Contenidos del paquete**  
**Packungsinhalt**  
**Contenuto della confezione**  
**包装内容**

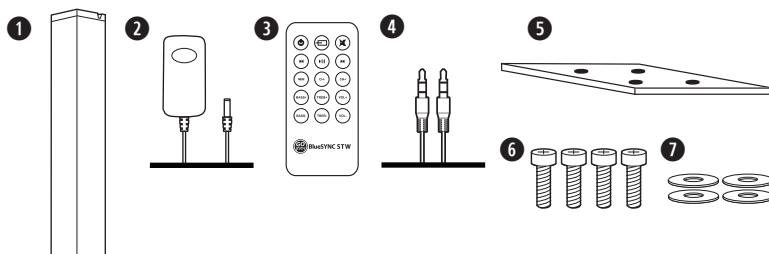

**EN**

- 1 BlueSYNC® STW
- 2 AC adapter
- 3 Remote Control
- 4 AUX cable
- 5 Base
- 6 Base screws (4)
- 7 Washers (4)

**FR**

- 1 BlueSYNC® STW
- 2 Adaptateur secteur
- 3 Télécommande
- 4 Câble AUX
- 5 Base
- 6 Vis pour la base (4)
- 7 Rondelles (4)

**ES**

- 1 BlueSYNC® STW
- 2 Adaptador de corriente alterna
- 3 Mando a distancia
- 4 Cable AUX
- 5 Base
- 6 Tornillos para la base (4)
- 7 Arandelas (4)

**DE**

- 1 BlueSYNC® STW
- 2 AC-Netzadapter
- 3 Fernbedienung
- 4 AUX-Kabel
- 5 Sockel
- 6 Sockelschrauben (4)
- 7 Scheiben (4)

**IT**

- 1 BlueSYNC® STW
- 2 Adattatore CA
- 3 Telecomando
- 4 Cavo AUX
- 5 Base
- 6 Viti della base (4)
- 7 Rondelle (4)

**ZH**

- 1 BlueSYNC® STW
- 2 AC适配器
- 3 遥控器
- 4 AUX线
- 5 底座
- 6 底座螺钉 (4)
- 7 垫圈 (4)

**Product diagram**  
**Schéma du produit**  
**Diagrama de product**  
**Producttabbildung**  
**Schema del prodotto**

产品图

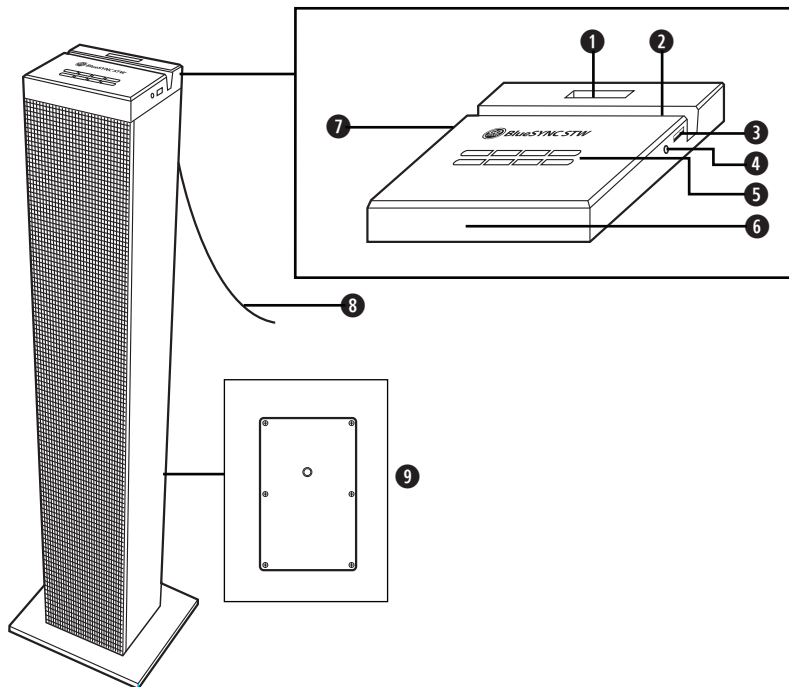

**EN**

- 1 Remote dock
- 2 Device dock
- 3 USB 1A charging port
- 4 AUX port
- 5 On-board controls
- 6 Screen
- 7 USB Flash drive input
- 8 FM antennae
- 9 Power input

**FR**

- 1 Station d'accueil pour la télécommande
- 2 Station d'accueil pour périphérique mobile
- 3 Port de charge USB 1A
- 4 Port AUX
- 5 Commandes intégrées
- 6 Écran
- 7 Lecteur Flash USB
- 8 Antenne FM
- 9 Entrée d'alimentation

**ES**

- 1 Base remota
- 2 Base del dispositivo
- 3 Puerto de carga USB 1A
- 4 Puerto AUX
- 5 Controles integrados
- 6 Pantalla
- 7 Entrada de unidad flash USB
- 8 Antena FM
- 9 Entrada de alimentación

**DE**

- 1 Dock für Fernbedienung
- 2 Dock für Geräte
- 3 USB-1-A-Ladeanschluss
- 4 AUX-Anschluss
- 5 Integrierte Kontrollknöpfe
- 6 Display
- 7 USB-Stick-Anschluss
- 8 FM-Antenne
- 9 Stromanschluss

**IT**

- 1 Dock station per telecomando
- 2 Dock station per dispositivo
- 3 Alimentatore USB 1A
- 4 USB-Stick-Anschluss
- 5 USB-1-A-Ladeanschluss
- 6 Display
- 7 Ingresso unità USB
- 8 Antenna FM
- 9 Ingresso alimentazione

**ZH**

- 1 遥控器基座
- 2 设备基座
- 3 USB 1A 充电端口
- 4 AUX 端口
- 5 面板控制器
- 6 屏幕
- 7 USB 闪存驱动器输入
- 8 FM 天线
- 9 电源输入

## Operating instructions

### Set-up

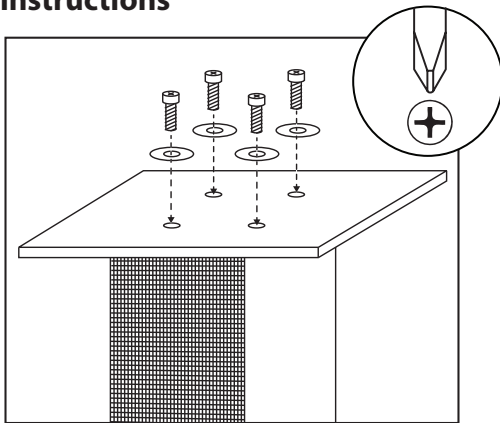

Place the washer on the screw and then insert through the base into the speaker.

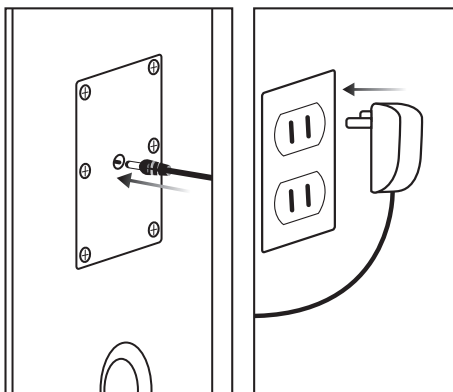

Plug AC adapter into BlueSYNC® STW and connect to power.

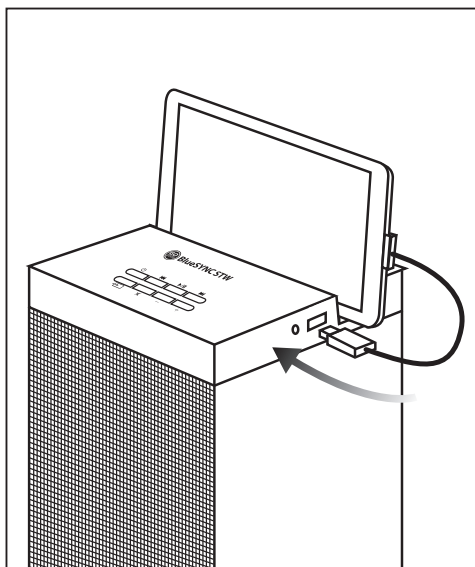

Use your device's USB cable to charge from the USB 1A charging port.

## Audio

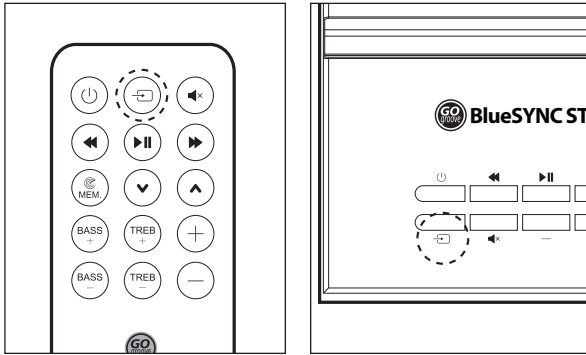

Use the Source button to cycle through audio modes.

## Bluetooth mode

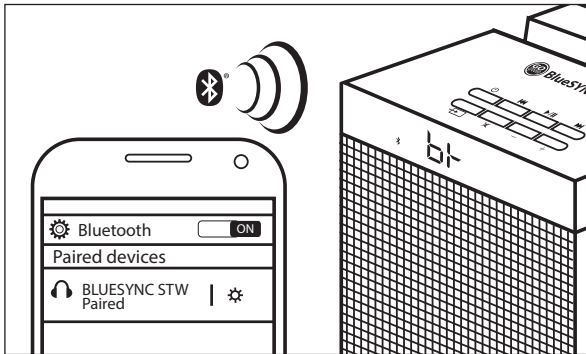

The screen will show a Bluetooth indicator blinking. Speaker will automatically enter pairing mode for 60 seconds. Pair your device (Use PIN 0000 if prompted). Once paired, the LED indicator will be solid.

## FM mode

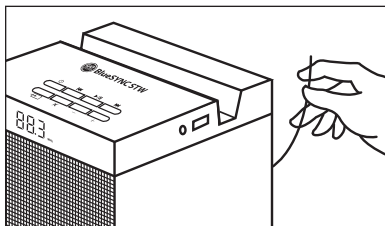

The screen will show a FM indicator. Adjust the antennae for best reception. Use the remote to scan available stations using the MEM button.

## AUX mode

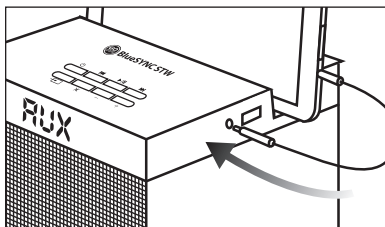

The screen will show AUX. Use the 3.5mm cable to connect to the AUX port and your device.



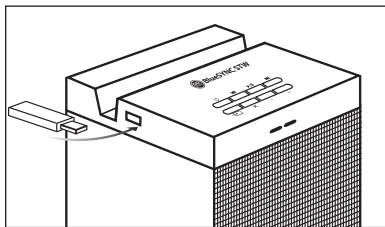



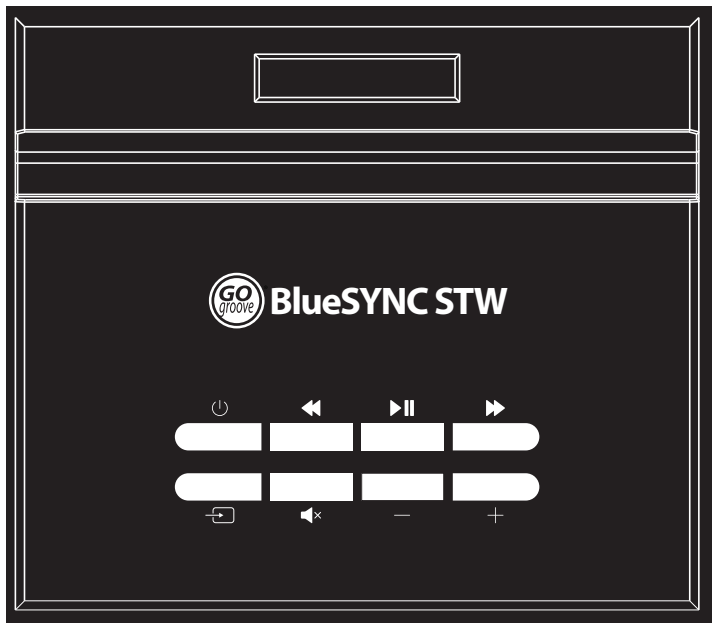

## USB mode



The screen will show --. Plug in a flash drive (32gb MAX) in to the USB Flash drive input.







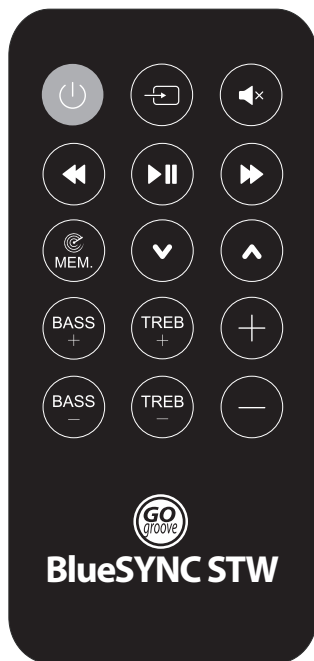

## On-board controls



Button	Press sequence	Function
	Quick press	Power ON/OFF
	Quick press	Bluetooth mode: Previous track FM mode: Tune down USB mode: Previous track
	Press and hold	FM mode: Previous station
	Quick press	Pause / Play
	Press and hold	Bluetooth mode: Re-enter pairing mode
	Quick press	Bluetooth mode: Next track FM mode: Tune up USB mode: Next track
	Press and hold	FM mode: Next station
	Quick press	Change audio source
	Quick press	Mute sound
	Press	Volume down
	Press	Volume up

## Remote control



Button	Press sequence	Function
	Quick press	Power ON/OFF
	Quick press	Change audio source
	Quick press	Mute sound
	Quick press	Bluetooth mode: Previous track USB mode: Previous track
	Press and hold	FM mode: Tune down
	Quick press	Pause / Play
	Press and hold	Bluetooth mode: Re-enter pairing mode
	Quick press	Bluetooth mode: Next track USB mode: Next track
	Press and hold	FM mode: Tune up
	Press	Scan and memorize available FM stations
	Press	FM mode: Next station
	Press	FM mode: Previous station
BASS +	Press	Increase bass
BASS -	Press	Decrease bass
TREB +	Press	Increase treble
TREB -	Press	Decrease treble
	Press	Volume up
	Press	Volume down

## Mode d'emploi

### Configuration

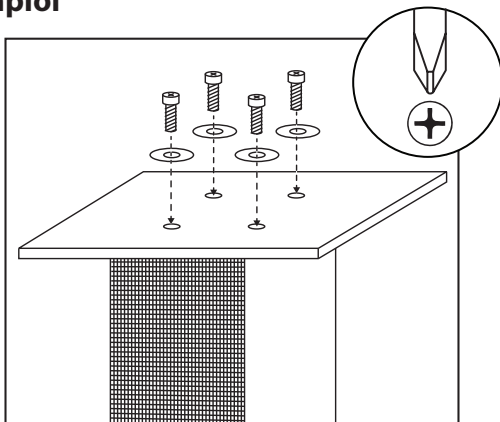

Placez la rondelle sur la vis puis vissez à travers la base et dans le haut-parleur.

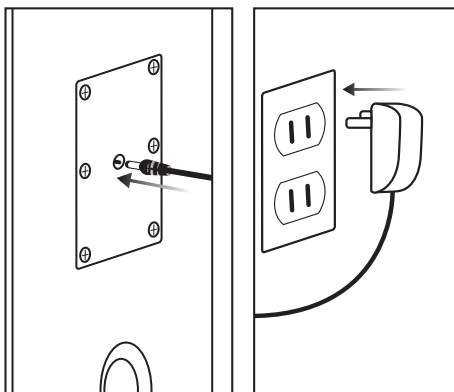

Raccorder l'adaptateur secteur à BlueSYNC® STW et branchez à une prise de courant.

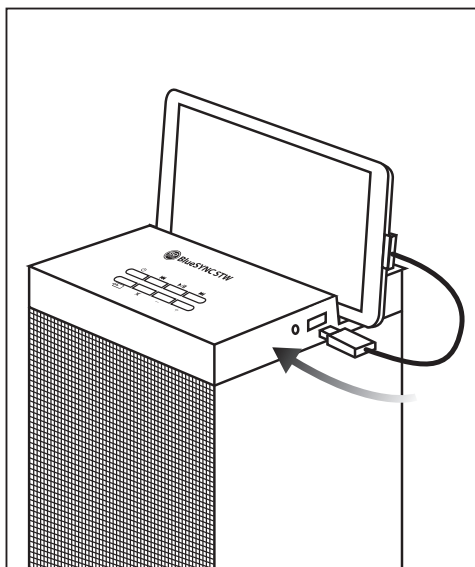

Utilisez le câble USB de votre périphérique mobile pour le charger depuis le port de charge USB 1A.

## Audio

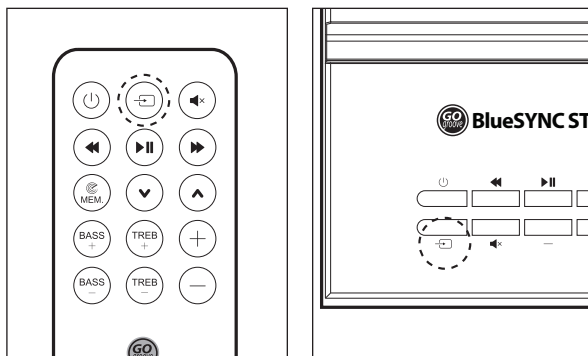

Utilisez le bouton Source pour faire défiler les modes audio.

## Mode Bluetooth

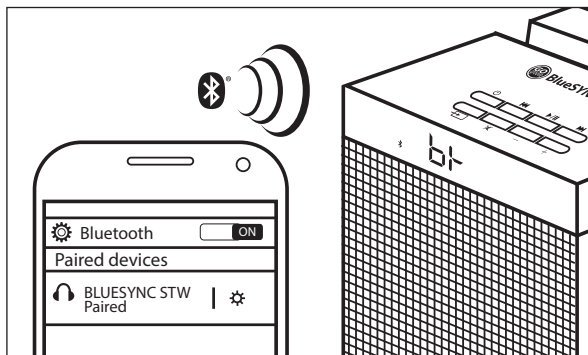

L'écran affichera un témoin Bluetooth clignotant. Le haut-parleur se mettra automatiquement en mode d'appariement pour une durée de 60 secondes. Apparez votre périphérique mobile (Utilisez le PIN 0000 si vous y êtes invité(e)). Une fois le périphérique apparié, le voyant de statut cessera de clignoter.

## Mode FM

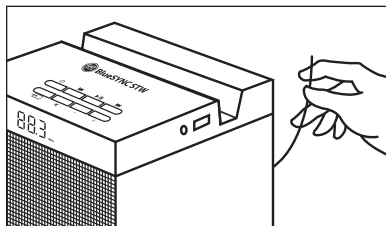

L'écran affichera un témoin FM. Ajustez l'antenne pour améliorer la réception. Utilisez la télécommande pour rechercher les stations disponibles à l'aide du bouton MEM.

## Mode AUX

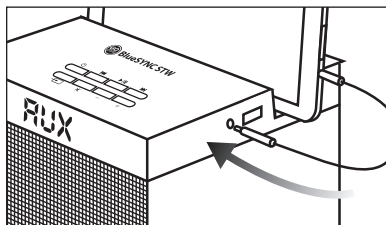

L'écran affichera AUX. Utilisez le câble de 3,5 mm pour relier le port AUX à votre périphérique mobile.



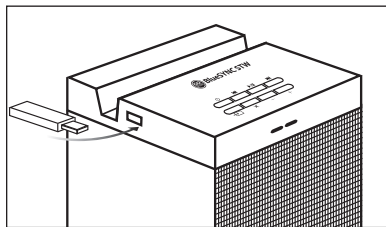



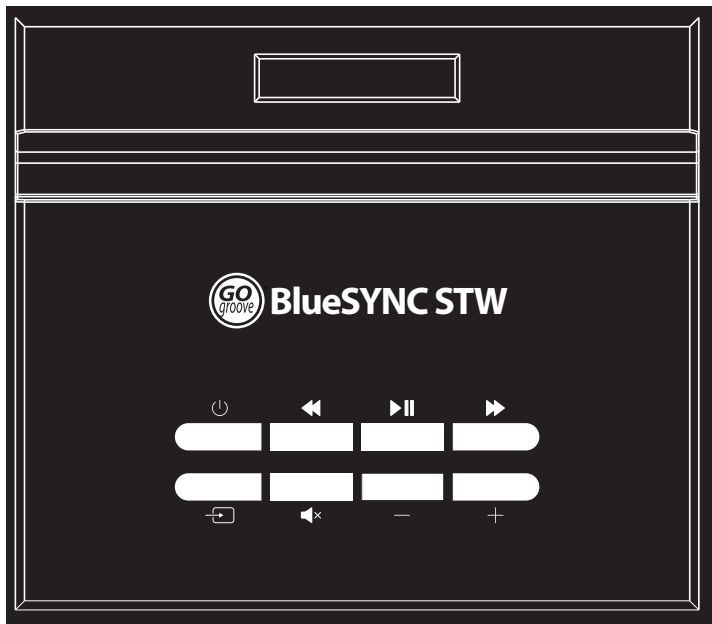

## Mode USB



L'écran affichera --. Insérez une clé USB (MAX 32 Go) dans le port d'entrée USB.









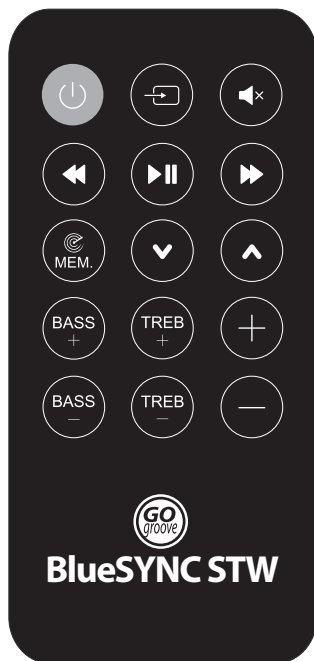

## Commandes intégrées



Bouton	Séquence de boutons	Fonction
	Appui rapide	Power Marche /Arrêt
	Appui rapide	Mode Bluetooth : Morceau précédent Mode FM : Diminuer la fréquence Mode USB : Morceau précédent
	Maintenir appuyé	Mode FM : Station précédente
	Appui rapide	Pause / Lecture
	Maintenir appuyé	Mode Bluetooth : retour au mode d'appariement
	Appui rapide	Mode Bluetooth : Morceau suivant Mode FM : Augmenter la fréquence Mode USB : Morceau suivant
	Maintenir appuyé	Mode FM : station suivante
	Appui rapide	Changer la source audio
	Appui rapide	Mode muet
	Appuyer	Diminuer le volume
	Appuyer	Augmenter le volume

## Télécommande



Bouton	Séquence de boutons	Fonction
	Appui rapide	Power Marche /Arrêt
	Appui rapide	Changer la source audio
	Appui rapide	Mode muet
	Appui rapide	Mode Bluetooth : Morceau précédent Mode USB : Morceau précédent
	Maintenir appuyé	Mode FM : Augmenter la fréquence
	Appui rapide	Pause / Lecture
	Maintenir appuyé	Mode Bluetooth : retour au mode d'appariement
	Appui rapide	Mode Bluetooth : Morceau suivant Mode USB : Morceau suivant
	Maintenir appuyé	Mode FM : Diminuer la fréquence
 MEM.	Appuyer	Rechercher et mémoriser les stations FM disponibles
	Appuye	Mode FM : station suivante
	Appuye	Mode FM : Station précédente
BASS +	Appuyes	Augmenter les basses
BASS -	Appuye	Baisser les basses
TREB +	Appuye	Augmenter les aigus
TREB -	Appuye	Baisser les aigus
	Appuye	Augmenter le volume
	Appuye	Baisser le volume

## Instrucciones de Operación

### Montaje

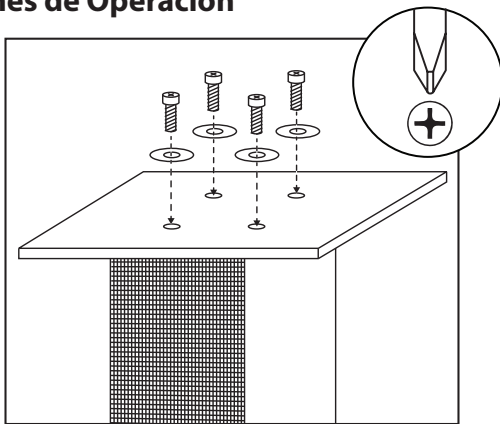

Coloque la arandela en el tornillo y luego introdúzcalo a través de la base en el altavoz.

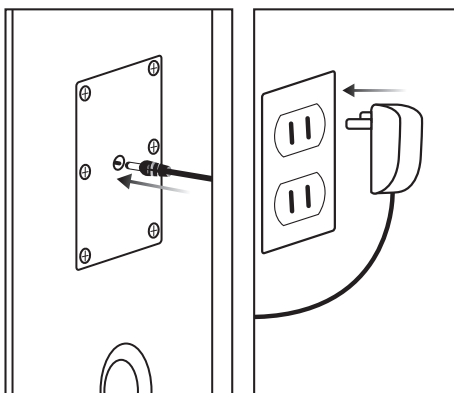

Enchufe el adaptador CA en el BlueSYNC® STW y conéctelo a la corriente.

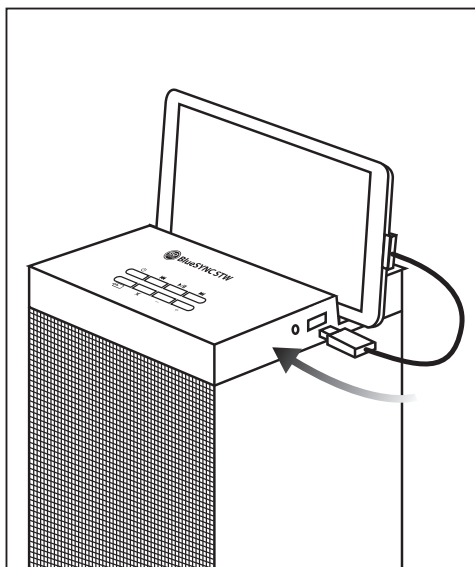

Use el cable usb de su dispositivo para efectuar la carga desde un puerto de carga USB 1A

## Audio

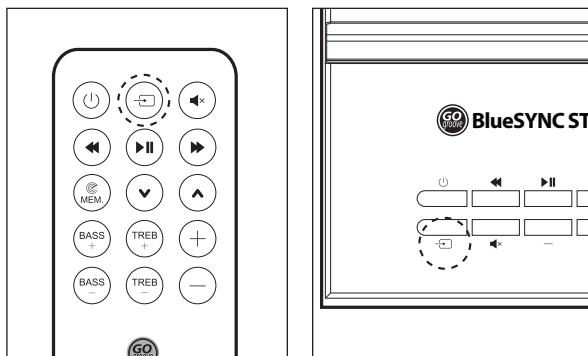

Utilice el botón Source para alternar entre los modos de audio.

## Modo Bluetooth

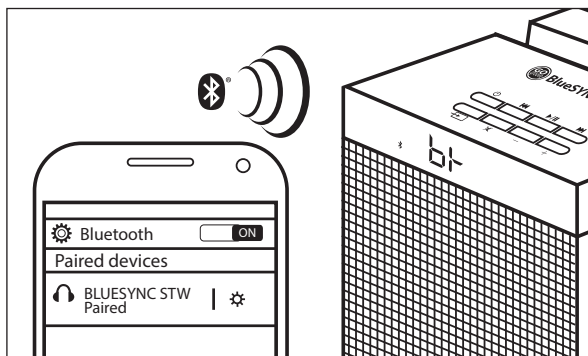

La pantalla mostrará un indicador de bluetooth intermitente. El altavoz entrará en el modo de acoplamiento automáticamente cuando transcurran unos 60 segundos. Acople su dispositivo (use el PIN 0000 si se le requiere). Una vez acoplado, el indicador LED dejará de parpadear.

## Modo FM

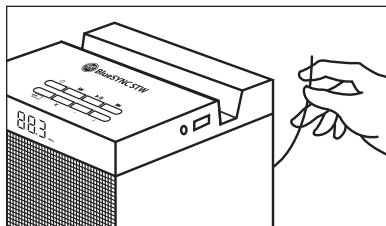

La pantalla mostrará un indicador de FM. Ajuste la antena para conseguir una mejor recepción de señal. Use el mando a distancia para explorar las emisoras disponibles mediante el botón MEM.

## Modo AUX

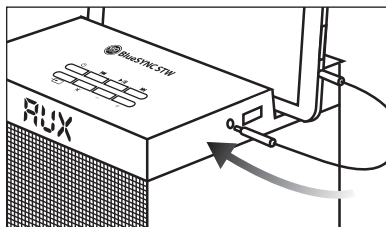

La pantalla mostrará la palabra AUX. Use el cable de 3.5 mm para conectar el puerto AUX y su dispositivo.



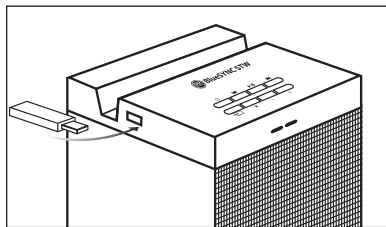



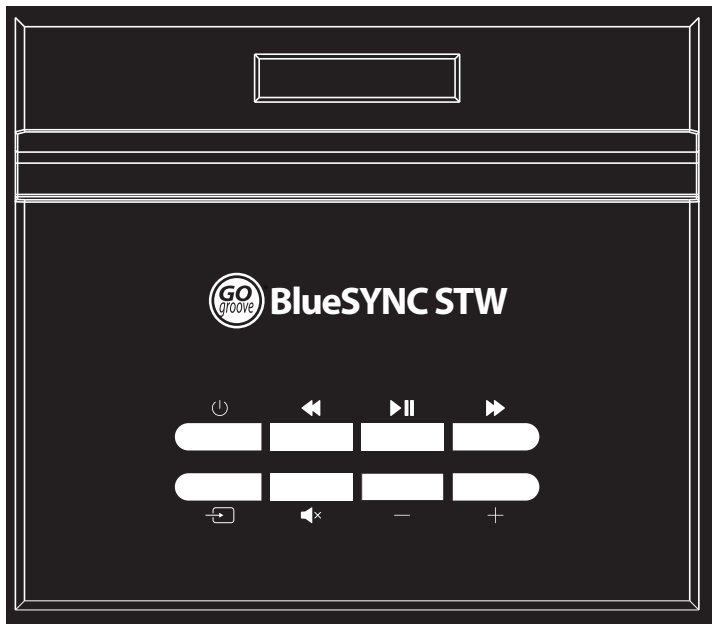

## Modo USB



La pantalla mostrará el símbolo -. Conecte una unidad flash (máximo 32 gb) en la entrada de la unidad Flash USB.









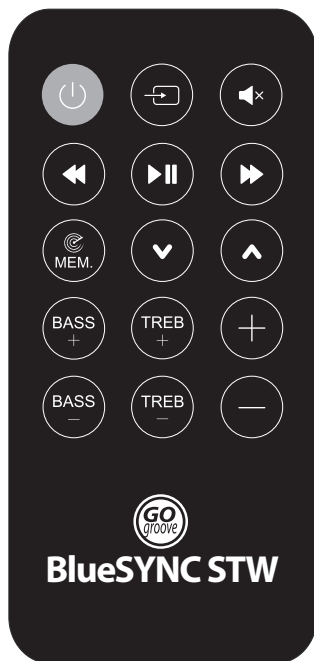

## Controles integrados



Botón	Presione la secuencia	Función
	Presione rápido	Encendido / apagado
	Presione rápido	Modo Bluetooth: pista anterior Modo FM: sintonizar abajo Modo USB: pista anterior
	Presione y mantenga	Modo FM: emisora anterior
	Presione rápido	Pausar / reproducir
	Presione y mantenga	Modo Bluetooth: volver a introducir el modo de acoplamiento
	Presione rápido	Modo Bluetooth: pista siguiente Modo FM: sintonizar arriba Modo USB: pista siguiente
	Presione y mantenga	Modo FM: emisora siguiente
	Presione rápido	Cambiar la fuente de audio
	Presione rápido	Sonido silenciado
	Presione	Bajar el volumen
	Presione	Subir el volumen

## Mando a distancia



<b>Botón</b>	<b>Presione la secuencia</b>	<b>Función</b>
	Presione rápido	Encendido / apagado
	Presione rápido	Cambiar la fuente de audio
	Presione rápido	Sonido silenciado
	Presione rápido	Modo Bluetooth: pista anterior Modo USB: pista anterior
	Presione y mantenga	Modo FM: sintonizar abajo
	Presione rápido	Pausar / reproducir
	Presione y mantenga	Modo Bluetooth: volver a introducir el modo de acoplamiento
	Presione rápido	Modo Bluetooth: pista siguiente Modo USB: pista siguiente
	Presione y mantenga	Modo FM: sintonizar arriba
 MEM.	Presione	Explore y memorice las emisoras FM disponibles
	Presione	Modo FM: emisora siguiente
	Presione	Modo FM: emisora anterior
BASS +	Presione	Incrementar los bajos
BASS -	Presione	Disminuir los bajos
TREB +	Presione	Incrementar los agudos
TREB -	Presione	Disminuir los agudos
	Presione	Subir el volumen
	Presione	Bajar el volumen

# Bedienungsanleitung

## Einrichtung

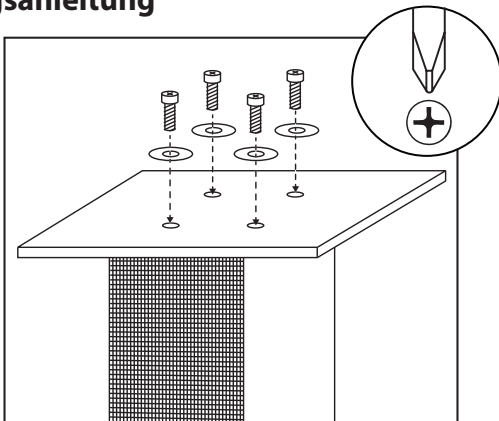

Legen Sie die Scheibe auf die Schraube und führen Sie sie dann durch den Sockel in den Lautsprecher ein.

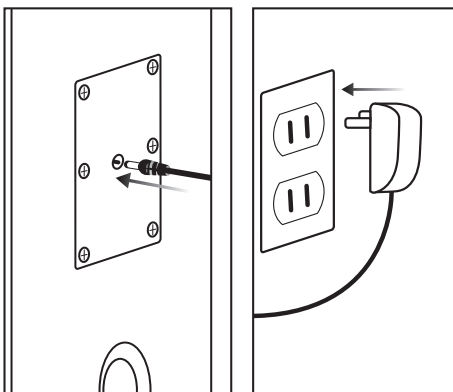

Stecken Sie den AC-Netzadapter in den BlueSYNC® STW und schließen Sie ihn dann an die Stromversorgung an.

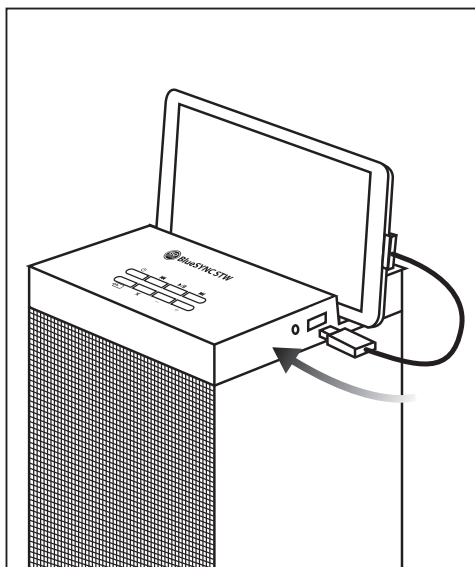

Nutzen Sie das USB-Kabel Ihres Geräts, um es über den USB-1-A-Ladeanschluss aufzuladen.

## Audio

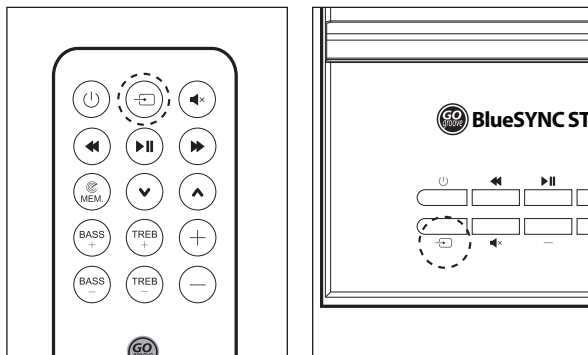

Nutzen Sie den Quelle-Button, um durch die Audiomodi zu schalten.

## Bluetooth-Modus

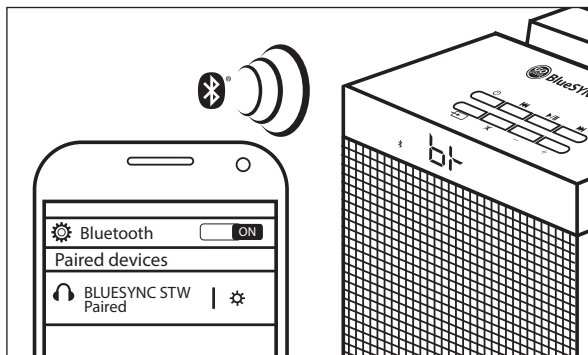

Das Display zeigt ein blinkendes Bluetooth-Kennzeichen. Der Lautsprecher geht automatisch für 60 Sekunden in den Kopplungs-Modus. Koppeln Sie Ihr Gerät (verwenden Sie bei Aufforderung die PIN 0000). Bei erfolgreicher Kopplung leuchtet die LED-Anzeige dauerhaft.

## FM-Modus

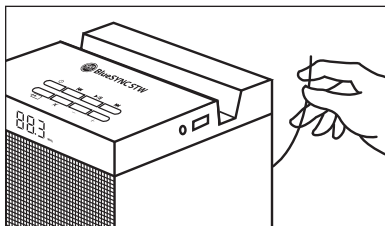

Das Display zeigt ein FM-Kennzeichen.  
Richten Sie die Antenne für einen optimalen Empfang aus.  
Verwenden Sie die Fernbedienung, um die verfügbaren Sender durch Verwenden des MEM-Buttons abzutasten.

## AUX-Modus

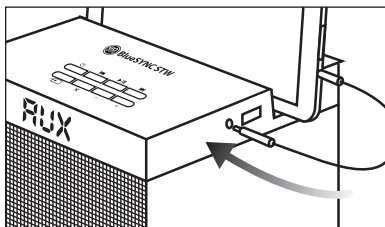

Das Display zeigt AUX an. Verwenden Sie das 3,5-mm-Kabel, um den AUX-Anschluss und Ihr Gerät zu verbinden.



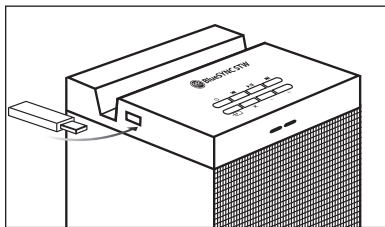



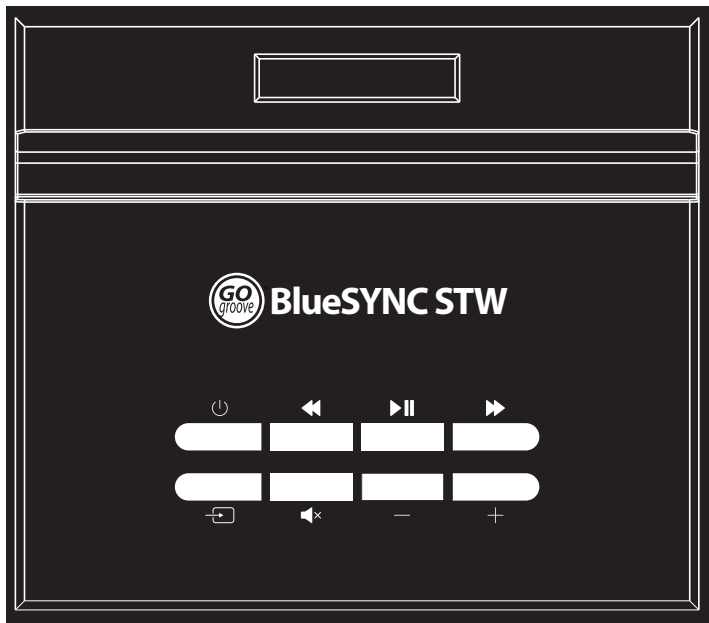

## USB-Modus



Das Display zeigt -- an. Stecken Sie Ihren USB-Stick (maximal 32 GB) in den USB-Stick-Anschluss.









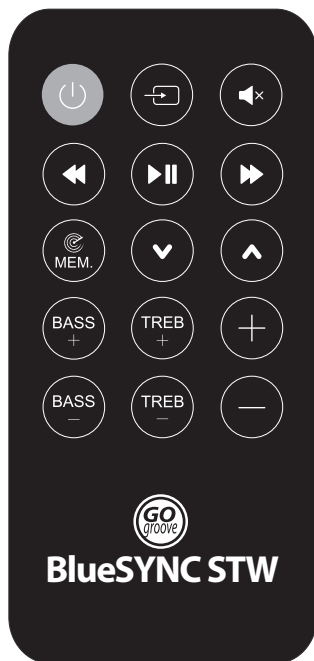

## Integrierte Kontrollknöpfe



Button	Reihenfolge drücken	Funktion
		Power AN/AUS
		Bluetooth-Modus: Vorheriger Track FM-Modus: Sender nach unten verstellen USB-Modus: Vorheriger Track
		FM-Modus: Vorheriger Sender
		Pause / Play
		Bluetooth-Modus: Kopplungs-Modus erneut aufrufen
		Bluetooth-Modus: Nächster Track FM-Modus: Sender nach oben verstellen USB-Modus: Nächster Track
		FM-Modus: Nächster Sender
		Audio-Quelle wechseln
		Sound stummschalten
		Lautstärke runter
		Lautstärke rauf

## Fernbedienung



Button	Reihenfolge drücken	Funktion
	Kurz drücken	Power AN/AUS
	Kurz drücken	Audio-Quelle wechseln
	Kurz drücken	Sound stummschalten
	Kurz drücken	Bluetooth-Modus: Vorheriger Track USB-Modus: Vorheriger Track
	Gedrückt halten	FM-Modus: Sender nach unten verstellen
	Kurz drücken	Pause / Play
	Gedrückt halten	Bluetooth-Modus: Kopplungs-Modus erneut aufrufen
	Kurz drücken	Bluetooth-Modus: Nächster Track USB-Modus: Nächster Track
	Gedrückt halten	FM-Modus: Sender nach oben verstellen
 MEM.	Drücken	Verfügbare FM-Sender abtasten und speichern
	Drücken	FM-Modus: Nächster Sender
	Drücken	FM-Modus: Vorheriger Sender
BASS +	Drücken	Bass erhöhen
BASS -	Drücken	Bass verringern
TREB +	Drücken	Treble erhöhen
TREB -	Drücken	Treble verringern
	Drücken	Lautstärke rauf
	Drücken	Lautstärke runter

## Istruzioni operative

### Installazione

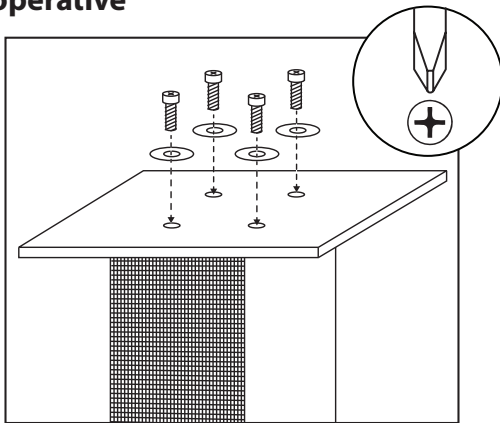

Posizionare la rondella sulla vite e inserire nell'altoparlante passando attraverso la base.

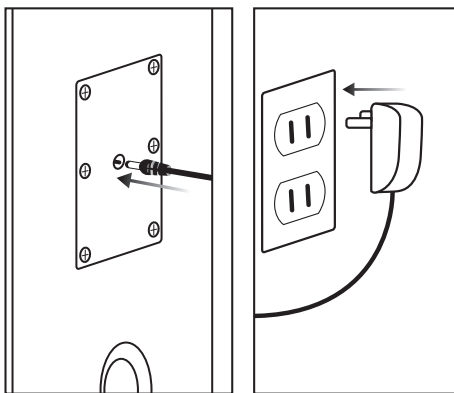

Collegare l'adattatore CA al BlueSYNC® STW e collegare all'alimentazione.

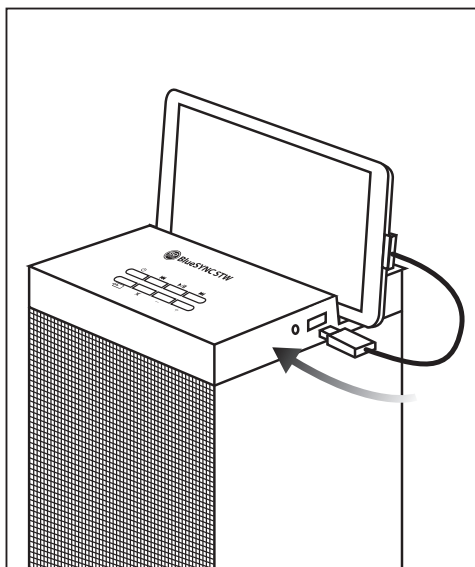

Usare il cavo USB del proprio dispositivo per ricaricarlo dall'alimentatore USB 1A.

## Audio

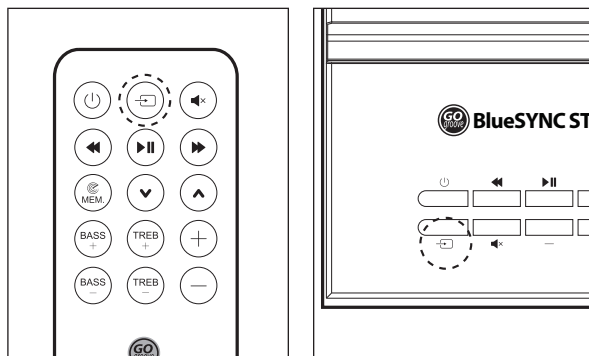

Usare il tasto Sorgente per scorrere le modalità audio.

## Modalità Bluetooth

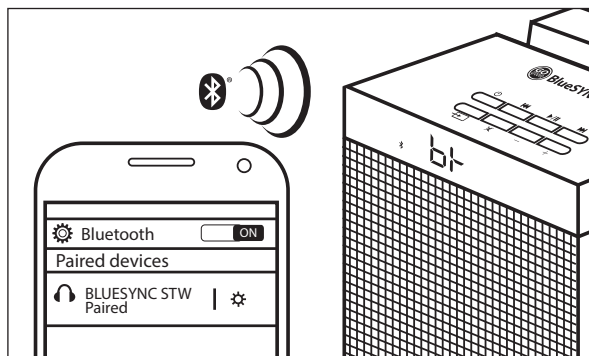

Sul display comparirà un indicatore Bluetooth lampeggiante. L'altoparlante entrerà automaticamente in modalità accoppiamento per 60 secondi. Accoppiare il proprio dispositivo (inserire il PIN 0000 se richiesto). Una volta accoppiato, l'indicatore LED sarà fisso.

## Modalità FM

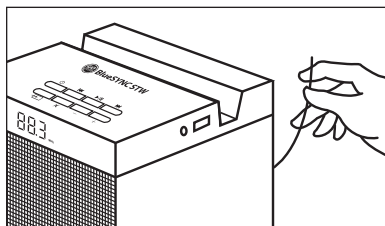

Sul display comparirà un indicatore FM. Regolare l'antenna per migliorare la ricezione. Usare il telecomando per cercare le stazioni disponibili usando il tasto MEM.

## Modalità AUX

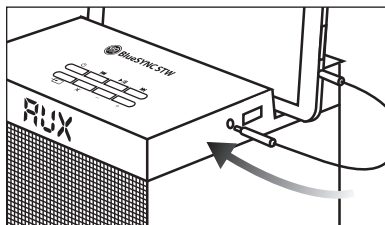

Sul display comparirà un indicatore AUX. Usare il cavo di 3,5 mm per collegarsi alla porta AUX e al proprio dispositivo.



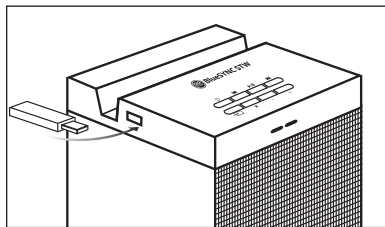



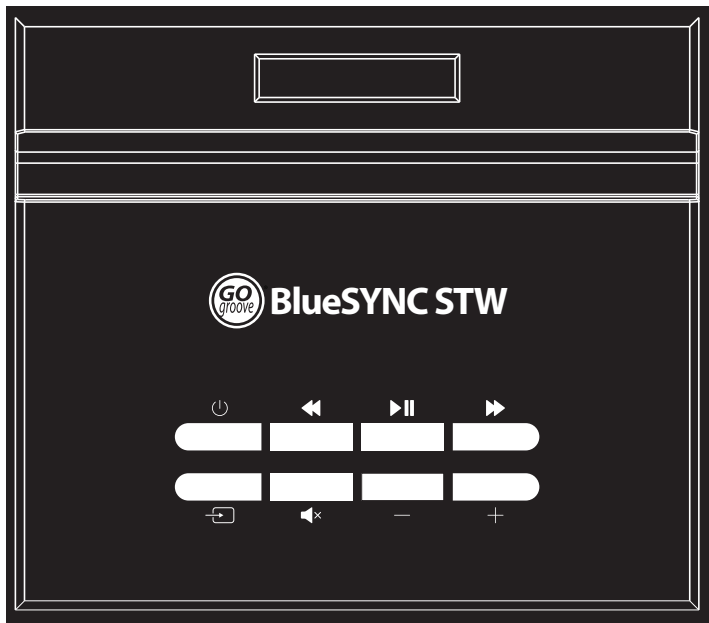

## Modalità USB



Sul display comparirà il simbolo --. Inserire un'unità USB (max 32 GB) nell'ingresso USB.









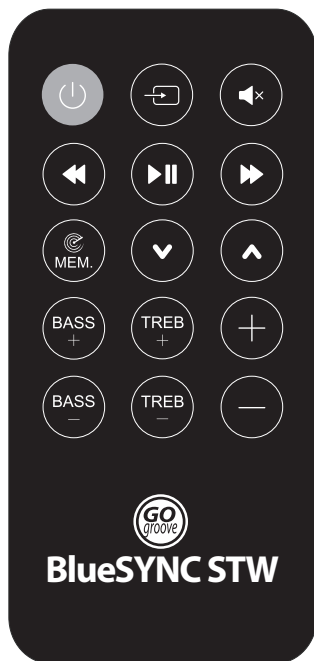

## Controlli diretti



<b>Tasto</b>	<b>Sequenza di pressione</b>	<b>Funzione</b>
	Premere brevemente	Tasto ON/OFF
	Premere brevemente	Modalità Bluetooth: Traccia precedente Modalità FM: Frequenza giù Modalità USB: Traccia precedente
	Premere e tenere premuto	Modalità FM: Stazione precedente
	Premere brevemente	Pausa / Play
	Premere e tenere premuto	Modalità Bluetooth: Riattiva modalità accoppiamento
	Premere brevemente	Modalità Bluetooth: Traccia successiva Modalità FM: Frequenza su Modalità USB: Traccia successiva
	Premere e tenere premuto	Modalità FM: Stazione successiva
	Premere brevemente	Cambia sorgente audio
	Premere brevemente	Silenzioso
	Premere	Volume giù
	Premere	Volume su

## Telecomando



Tasto	Sequenza di pressione	Funzione
	Premere brevemente	Tasto ON/OFF
	Premere brevemente	Cambia sorgente audio
	Premere brevemente	Suono silenzioso
	Premere brevemente	Modalità Bluetooth: Traccia precedente Modalità USB: Traccia precedente
	Premere e tenere premuto	Modalità FM: Frequenza giù
	Premere brevemente	Pausa / Play
	Premere e tenere premuto	Modalità Bluetooth: Riattiva modalità accoppiamento
	Premere brevemente	Modalità Bluetooth: Traccia successiva Modalità USB: Traccia successiva
	Premere e tenere premuto	Modalità FM: Frequenza su
 MEM.	Premere	Trova e memorizza le stazioni FM disponibili
	Premere	Modalità FM: Stazione successiva
	Premere	Modalità FM: Stazione precedente
BASS +	Premere	Aumenta i bassi
BASS -	Premere	Diminuisce i bassi
TREB +	Premere	Aumenta gli alti
TREB -	Premere	Diminuisce gli alti
	Premere	Volume su
	Premere	Volume giù

ZH

## 操作指令

安装

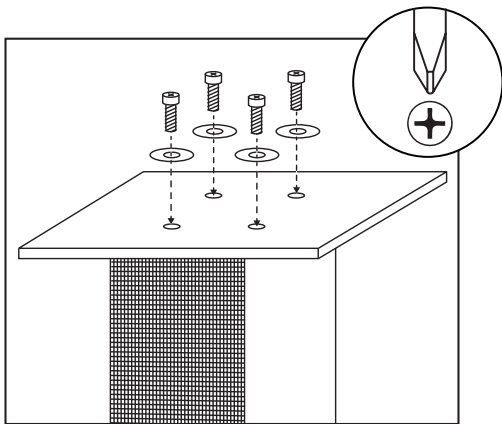

将垫圈放在螺丝上，然后穿过底座插入扬声器。

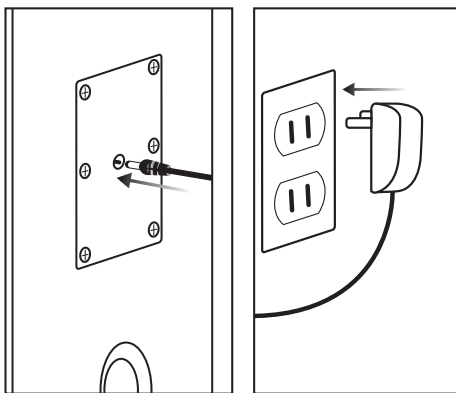

将AC适配器插入BlueSYNC®STW并连接电源。

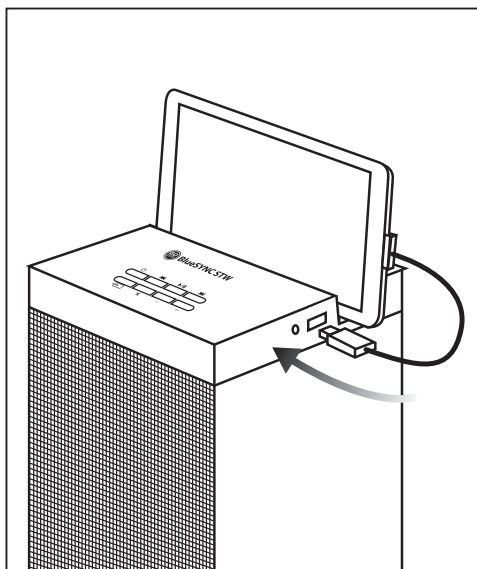

使用你的设备的USB线缆，从USB 1A充电端口充电。

## 音频

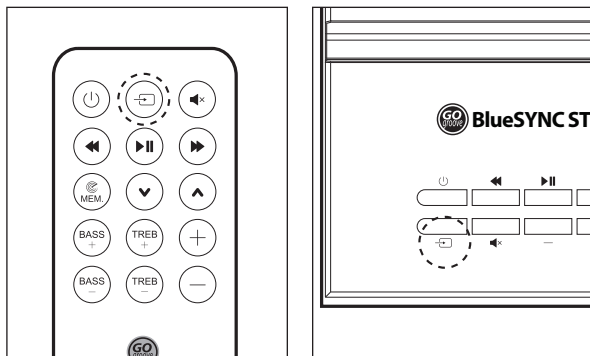

使用信号源按钮循环播放音频模式。

## 蓝牙模式

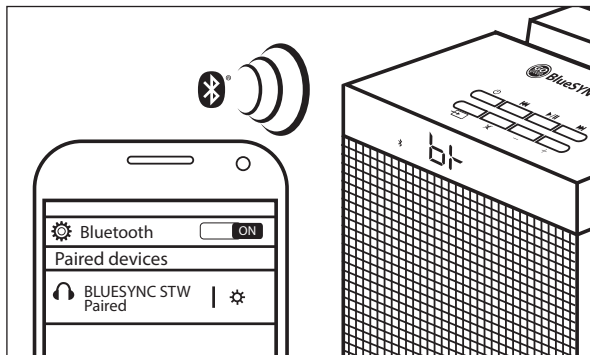

屏幕将显示蓝牙指示灯正在闪烁。扬声器会自动进入配对模式60秒。配对你的设备（如果出现提示，请使用PIN 0000）。完成后，LED指示灯将亮起并不再闪烁。

## FM模式

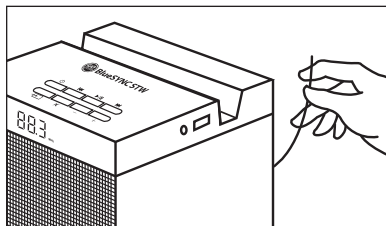

屏幕将显示一个FM指示灯。  
调整天线以达到最佳接收效果。  
使用遥控器上的MEM按钮扫描可用的电台。

## AUX模式

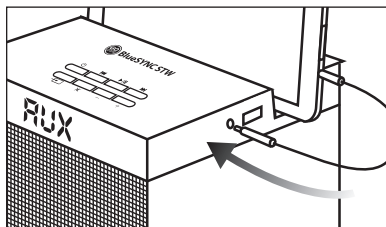

屏幕将显示AUX。使用3.5mm线缆  
连接AUX端口与你的设备。

## USB模式

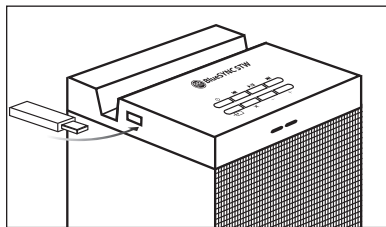

屏幕将显示--。将闪存驱动器（最大32GB）  
接入USB闪存驱动器输入口。

## 面板控制器

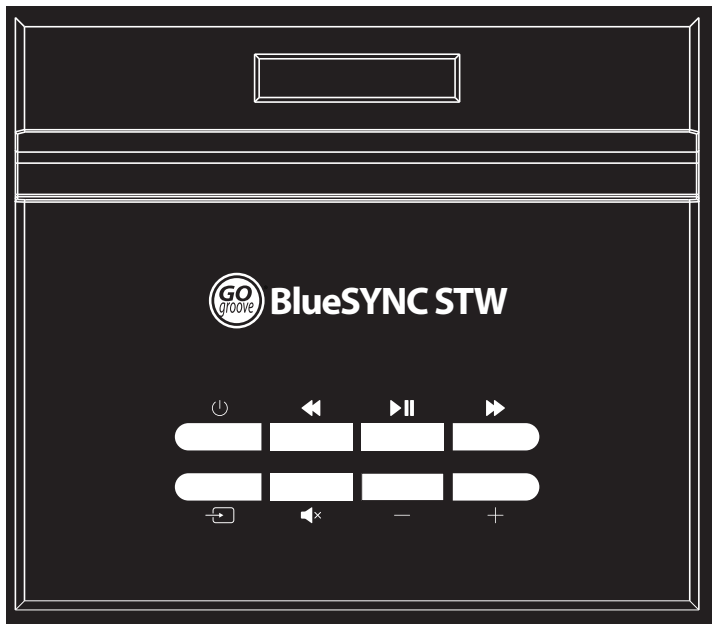

按钮	按的顺序	功能
	快速按	电源开/关
	快速按	蓝牙模式：上一首曲目 FM模式：调低 USB模式：上一首曲目
	按住并保持	FM模式：上一个电台
	快速按	暂停/播放
	按住并保持	蓝牙模式：重新进入配对模式
	快速按	蓝牙模式：下一首曲目 FM模式：调高 USB模式：下一首曲目
	按住并保持	FM模式：下一个电台
	快速按	更改音频源
	快速按	静音
	按一下	调低音量
	按一下	调高音量

## 遥控

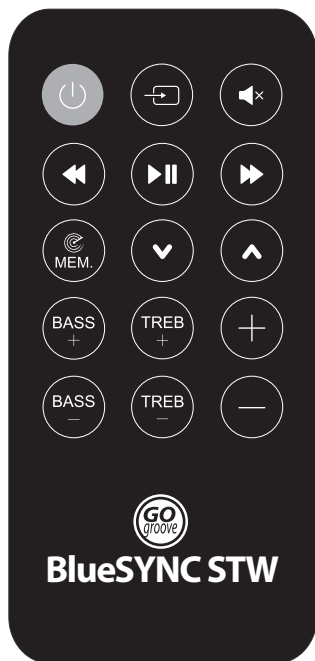

按钮	按的顺序	功能
	快速按	电源开/关
	快速按	更改音频源
	快速按	静音
	快速按	蓝牙模式：上一首曲目 USB模式：上一首曲目
	按住并保持	FM模式：调低
	快速按	暂停/播放
	按住并保持	蓝牙模式：重新进入配对模式
	快速按	蓝牙模式：下一首曲目 USB模式：下一首曲目
	按住并保持	FM模式：调高
	按一下	扫描并记忆可用的FM电台
	按一下	FM模式：下一个电台
	按一下	FM模式：上一个电台
BASS +	按一下	增加高音
BASS -	按一下	减少低音
TREB +	按一下	增加高音
TREB -	按一下	减少高音
	按一下	调高音量
	按一下	调低音量

WARRANTY GARANTIE GARANTÍA



GARANTIE GARANZIA 保固

This product comes with a 1 year limited warranty, the acceptance of which is a condition of sale. Register this product within 30 days of sale to activate a complimentary 2 year warranty extension and receive free advanced technical support. For warranty program details, registration, and support visit [GOgroove.com/warranty](http://GOgroove.com/warranty)

Ce produit à une garantie limitée de 1 an, la condition étant son achat. Enregistrer ce produit dans les 30 jours suivant son achat pour activer l'extension de garantie de 2 ans et bénéficier de notre service après-vente gratuit. Pour en savoir plus sur l'enregistrement et le service après-vente allez sur [GOgroove.com/warranty](http://GOgroove.com/warranty)

Este producto viene con una garantía limitada de 1 año, la aceptación de que es una condición de la venta. Registrar este producto dentro de los 30 días de la venta para activar una extensión de cortesía 2 años de garantía y recibir soporte técnico avanzado libre. Para los detalles del programa de garantía, el registro, y una visita de apoyo [GOgroove.com/warranty](http://GOgroove.com/warranty)

Dieses Produkt kommt mit einer 1-Jahres-Garantie, deren Annahme ist eine Bedingung des Verkaufs. Registrieren Sie dieses Produkt innerhalb von 30 Tagen den Verkauf an ein kostenloses 2 Jahre / Garantie-Erweiterung zu aktivieren und erhalten kostenlos erweiterte technische Unterstützung. Für Garantie-Programm Details, Registrierung und Support Besuch [GOgroove.com/warranty](http://GOgroove.com/warranty)

Questo prodotto viene fornito con una garanzia limitata di 1 anno, la cui accettazione è una condizione di vendita. Registra questo prodotto entro 30 giorni di vendita per attivare tutte le mattine una estensione di garanzia di 2 anni e di ricevere supporto tecnico avanzato gratuito. Per i dettagli del programma di garanzia, la registrazione e supporto visitare [GOgroove.com/warranty](http://GOgroove.com/warranty)

本产品带有1年有限保修的销售承诺。在购买后30天内注册本产品将获得2年延长保修及得到免费高级技术支持。关于保修流程的细节、注册和支持，请访问 [GOgroove.com/warranty](http://GOgroove.com/warranty)

This device complies with Part 15 of the FCC Rules. Operation is subject to the following two conditions: 1) this device may cause harmful interference, and 2) this device must accept any interference received, including interference that may cause undesired operation. Compliance Information Statements: This equipment has been tested and found to comply with the limits for a Class B digital device, pursuant to Part 15 of the FCC Rules. These limits are designed to provide reasonable protection against harmful interference in a residential installation. This equipment generates uses and can radiate radio frequency energy and, if not installed and used in accordance with the instructions, may cause harmful interference to radio communications. However, there is no guarantee that interference will not occur in a particular installation. If this equipment does cause harmful interference to radio or television reception, which can be determined by turning the equipment off and on, the user is encouraged to try to correct the interference by one or more of the following measures: 1) reorient or relocate the receiving antenna; 2) increase the separation between the equipment and receiver; 3) connect the equipment into an outlet on a circuit different from that to which the receiver is connected; 4) consult the dealer or an experienced radio/TV technician for help. Modifications to this product not authorized by Accessory Power could void your right to use or operate this product by the FCC. Where shielded interface cables or accessories have been provided with the product or specified additional components or accessories elsewhere detailed to be used with the installation of the product, they must be used in order to ensure compliance with FCC regulations.

The Bluetooth word mark and logos are registered trademarks owned by Bluetooth SIG, Inc. and any use of such marks by Accessory Power is under license.

© 2018 AP Global, Inc. All rights reserved. Accessory Power, the Accessory Power logo, GOgroove, the GOgroove logo, BlueSYNC and other marks and logos are either registered trademarks or trademarks of AP Global, Inc. in the United States and/or other countries. All other trademarks are the property of their respective owners.

**Manufactured in China. Designed in California.**

© 2018 AP Global, Inc. Tous droits réservés. Accessory Power, le logo Accessory Power, GOgroove, le logo GOgroove, BlueSYNC et les autres marques et logos sont des marques déposées ou des marques de AP Global, Inc. aux États-Unis et/ou dans d'autres pays. Toutes les autres marques sont la propriété de leurs propriétaires respectifs.

**Fabriqué en Chine. Conçu en Californie.**

**WARNING: This product contains chemical(s) known to the State of California to cause cancer, birth defects, or other reproductive harm.**

**Why does Accessory Power provide a California Proposition 65 warning?**

A Proposition 65 warning means one of two things: (1) the business has evaluated the exposure and has concluded that it exceeds the "no significant risk level"; or (2) the business has chosen to provide a warning simply based on its knowledge about the presence of a listed chemical without attempting to evaluate the exposure. Accessory Power has chosen to provide a warning based on its knowledge about the presence of one or more listed chemicals without attempting to evaluate the level of exposure. With this product, the exposure may be negligible or well within the "no significant risk" range; however, out of an abundance of caution, Accessory Power has elected to provide the consumer a warning regarding Proposition 65.

For more information please visit <https://www.accessorypower.com/prp65>

#### Product specifications Spécifications du produit Especificaciones del producto Produktspezifikationen Spécifiche del prodotto 产品规格

Audio Input: Bluetooth, 3.5mm AUX, USB Flash Drive, FM radio  
Speaker power: 2 x 15w driver + 30w woofer; 60w RMS, 120 Peak  
Power input: 15V – 3A  
USB power output: 5v – 1A  
Impedance: 4ohms  
Sensitivity: 25dB ±3dB  
Frequency response: 40Hz- 20KHz  
Total harmonic distortion: <2.5%  
S/N Ratio: >45dB  
Dimensions: 38.25 x 9.87 x 8.5 inches  
Weight: 10.12 pounds

Entrée audio: Bluetooth, 3.5mm AUX, USB Flash Drive, FM radio  
Puissance du haut-parleur: 2 x 15w driver + 30w woofer; 60w RMS, 120 Peak  
Puissance entrée: 15V – 3A  
USB puissance sortie: 5v – 1A  
Impédance: 4ohms  
Sensibilité: 25dB ±3dB  
Réponse en fréquence: 40Hz- 20KHz  
Distorsion harmonique totale: <2.5%  
S/N Ratio: >45dB  
Dimensions: 97,15 x 24,81 x 21,59 cm  
Poids: 4,59 kg



Facebook.com/gogrooveaudio

Twitter.com/gogroove



BlueSYNC® STW

MODEL NUMBER: GGBSTW100BKUS



GOgroove.com/recycle

