



VLML-4X2KM4K



4x2 Modular Multiview Processor

User Manual



HDMI[®]

HIGH-DEFINITION MULTIMEDIA INTERFACE

The terms HDMI, HDMI High-Definition Multimedia Interface, and the HDMI Logo are trademarks or registered trademarks of HDMI Licensing Administrator, Inc.

Welcome to the VigilLink User Manual!

Thank you for your purchase. At VigilLink, we prioritize the end-user experience by focusing on ease of use, ensuring our solutions are straightforward to install and program for our valued dealers. Our mission goes beyond product development; we aim to create a seamless experience for both integrators and end-users.

We value your feedback and would love to hear about your experience. Positive feedback reassures us that we have achieved our goals. If there are any areas where we have not met your expectations, we encourage you to reach out and share your thoughts so we can understand your experience and work to exceed your expectations in the future.

Thank you again for your purchase, and we look forward to hearing from you!

Mickey Park, Founder and CEO, VigilLink

DISCLAIMERS

The information in this manual has been carefully checked and is believed to be accurate. VigilLink assumes no responsibility for any infringement of patents or other rights of third parties which may result from its use.

VigilLink assumes no responsibility for any inaccuracies that may be contained in this document. VigilLink also makes no commitment to update or to keep current the information contained in this document.

VigilLink reserves the right to make improvements to this document and/or product at any time and without notice.

COPYRIGHT NOTICE

No part of this document may be reproduced, transmitted, transcribed, stored in a retrieval system, or any of its part translated into any language or computer file, in any form or by any means—electronic, mechanical, magnetic, optical, chemical, manual, or otherwise—without express written permission and consent from VigilLink.

© Copyright 2023 by VigilLink. All Rights Reserved.

TRADEMARK ACKNOWLEDGMENTS

All products or service names mentioned in this document are trademarks of the companies with which they are associated.

SAFETY PRECAUTIONS

Please read all instructions before attempting to unpack, install or operate this equipment and before connecting the power supply. Please keep the following in mind as you unpack and install this equipment:

- Always follow basic safety precautions to reduce the risk of fire, electrical shock and injury to people.
- To prevent fire or shock hazard, do not expose the unit to rain, moisture or install this product near water.
- Never spill liquid of any kind on or into this product.
- Never push an object of any kind into this product through any openings or empty slots in the unit, as you may damage parts inside the unit.
- Do not attach the power supply cabling to building surfaces.
- Use only the supplied power supply unit (PSU). Do not use the PSU if it is damaged.
- Do not allow anything to rest on the power cabling or allow any weight to be placed upon it or any person walk on it.
- To protect the unit from overheating, do not block any vents or openings in the unit housing that provide ventilation and allow for sufficient space for air to circulate around the unit.
- Please completely disconnect the power when the unit is not in use to avoid wasting electricity.

CONTENTS

1. Introduction	1
2. Applications	2
3. Package Contents	2
4. System Requirements	2
5. Features	3
6. Operation Controls and Functions	4
6.1 Front Panel	4
6.2 Rear Panel.....	6
6.3 Module Card Installation.....	7
6.4 Card Removal	8
6.5 Serial Pinout and Defaults.....	9
6.6 OSD Menu	10
6.7 WebGUI Control.....	28
6.7.1 Upper Tab Windows.....	30
6.7.2 Window Layout Tab	31
6.7.3 Picture Tab.....	33
6.7.4 Audio Tabs.....	34
6.7.5 Input EDID Tab	36
6.7.6 HDCP Mode Tab.....	37
6.7.7 OSD Settings Tab	38
6.7.8 Logo Settings Tab.....	39
6.7.9 Ethernet Tab	40
6.7.10 Setup Tab	41
6.7.11 Information Tab	42
6.7.12 Module Tab	42
6.8 Telnet Control.....	43
6.9 Serial and Telnet Commands	43
7. Connection Diagram	65
8. Specifications	66
8.1 Technical Specifications.....	66
8.2 Video Specifications.....	67
8.3 Audio Specifications.....	69
8.3.1 Digital Audio.....	69
8.3.2 Analog Audio.....	70
8.4 Cable Specifications.....	71
9. Acronyms	72

INTRODUCTION

Video conference is an important and convenient way to communicate with people around the globe. If you want to express your thoughts clearly by sharing a variety of rich images, an integrated machine with multi-windowing and the option of video streaming & recording is a splendid idea. This Multiview Modular Processor is the product that will meet your requirements. Besides being a high-performance HDMI matrix switch with integrated scaling and multi-windowing technology it includes a module card slot which lets you expand its capabilities with video capture, streaming, and more!

Any of the 4 different HDMI sources may be displayed individually, full screen, with seamless switching in Matrix mode, or they can be displayed using a variety of multi-window modes including standard views like PiP and PoP as well as fully customizable quad-window modes. By installing an optional expansion card, the unit can be transformed into a flexible video streaming, distribution, and recording powerhouse! All HDMI ports, and the module output slot, support resolutions up to 18Gbps 4K UHD⁺.

An audio mixer function is also included, allowing multiple external audio sources to be mixed with the embedded audio of your HDMI source (LPCM 2.0 only) for your video output.

Comprehensive EDID management provides improved compatibility with different sink devices. The intuitive WebGUI provides easy control of your live event including source selection, resolution, window position, and more. Audio functions include volume level adjustment, mute, and mixer source selection. This unit can be controlled and configured via front panel buttons, an intuitive WebGUI, RS-232, or Telnet.

APPLICATIONS

- Entertainment Room & Home Theater
- Show Room & Demo Room
- Lecture Room & Hall Presentation
- Public Commercial Display
- Multiview Video Monitoring
- Many additional possible applications, including streaming, video extension, video recording and more depending on the expansion module installed!

PACKAGE CONTENTS

- 1× Multiview Modular Processor
- 1× 24V/2.7A DC Power Adapter
- 1× Operation Manual

SYSTEM REQUIREMENTS

- HDMI source equipment such as media players, video game consoles, or set-top boxes.
- HDMI receiving equipment such as HDTVs, monitors, or audio amplifiers.
- The use of Premium High Speed HDMI cables is highly recommended.
- CYP Module slot is designed for use with official SDM branded modules only.

FEATURES

- HDMI 2.0 and DVI 1.0 compliant (with the use of an HDMI-DVI adapter)
- HDCP 1.x and 2.2 compliant
- 4 HDMI inputs and 2 HDMI outputs and 1 SDM Output Module slot
- Supports up to 4K UHD⁺ (18Gbps, 4K@50/60Hz 4:4:4, 8-bit) video input and output

Note: HDR bypass is not supported.

- Supports the installation of CYP Module cards (SDM branded) to add additional output functionality
- Seamless switching (no loss of sync to display) when switching sources in Matrix mode
- Supports up to four simultaneous, freely scalable, windows in multi- windowing modes
- Supports the ability to store a multi-window arrangement as a preset that can be recalled later
- Independent audio source selection, gain control, and routing in all modes
- Each window can have a border with a selectable color
- Uploadable and freely positional graphic logo support
- Intuitive and easy adjustment of window size, position and settings in multi-window modes via the WebGUI
- Per-input EDID management with internal or external EDID options
- Controllable via front panel buttons, WebGUI, Telnet, and RS-232

OPERATION CONTROLS AND FUNCTIONS

1.1 Front Panel

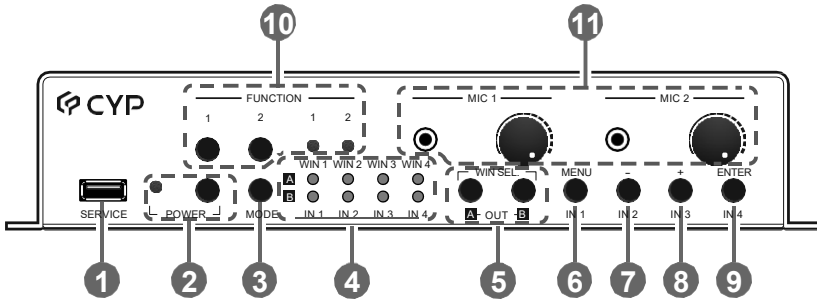

1 SERVICE Port (USB 2.0): This port is reserved for firmware update and user EDID/logo upload use only.

2 POWER Button & LED: Press this button to power the unit on (green LED) or place it into stand-by mode (red LED).

Note: Ethernet and RS-232 remain active when the unit is in stand-by mode.

3 MODE Button: Press this button to sequentially switch the operational mode between Matrix, PiP, PoP, and Quad.

4 VIN/IN 1~4 Output A/B LEDs: In Matrix mode, these LED's indicate the currently selected sources (IN 1~4) routed to each of the two outputs (OUT A~B). When the unit is in a multi-windowing mode (PiP/PoP/Quad/ Preset) the top row of LEDs represents the current window (WIN 1~4) and the bottom row represents the currently assigned input (IN 1~4).

Note: When source selection is active the associated LEDs will blink.

5 VIN SEL OUT A/B Buttons: In Matrix mode, press either of these buttons to activate discrete source selection for the associated output. In multi-windowing modes (PiP, PoP, Side-by-Side) either button will activate window selection, and additional presses will sequentially step through the available windows. Source selection mode will automatically be deactivated after 5 seconds with no user input.

Note: These buttons only activate the ability to change sources. Actual source selection is accomplished using the IN 1~4 buttons.

6 MENU/IN 1 Button: When not in source selection mode, press to enter the OSD menu, or to back out from menu items. When source selection is active, pressing this button will select input 1 for the currently selected output/window.

Note: Pressing "MENU" and "+" together will reset the output resolution to XGA (1024x768@60Hz). Pressing "MENU" and "-" together will reset the output resolution to 1080p@60Hz.

7 Minus (-)/IN 2 Button: When not in source selection mode, press to move down or adjust selections within OSD menus. When source selection is active, pressing this button will select input 2 for the currently selected output/window.

8 Plus (+)/IN 3 Button: When not in source selection mode, press to move up or adjust selections within OSD menus. When source selection is active, pressing this button will select input 3 for the currently selected output/window.

9 ENTER/IN 4 Button: When not in source selection mode, press to confirm a selection within the OSD. When source selection is active, pressing this button will select input 4 for the currently selected output/ window.

10 FUNCTION 1~2 Buttons and LEDs: The functionality of these buttons depends on the current SDM Module card installed (for example, starting and stopping recording, or streaming).

11 MIC 1~2 Volume Knobs & Ports: Connect each port to the analog mono output of a microphone. Rotate each mic's knob to increase or decrease the audio gain for the associated microphone.

Note: Microphone input gain can only be controlled via these physical knobs and cannot be modified through the WebGUI or Telnet.

1.2 Rear Panel

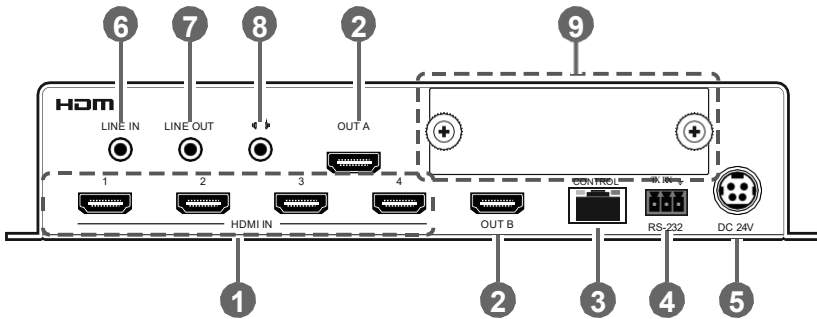

- 1 HDMI IN 1~4 Ports:** Connect to HDMI source equipment such as players, game consoles, or set-top boxes.
- 2 OUT A~B Ports:** Connect to HDMI TVs, monitors, or amplifiers for digital video and audio output.

Note: In multiviewer modes, outputs A & B will always output the same video.

- 3 CONTROL Port:** Connect directly, or through a network switch, to your PC/laptop to control the unit via Telnet/WebGUI.
- 4 RS-232 3-pin Terminal Block:** Connect directly to a PC, laptop, or other serial control device with a 3-pin adapter cable to send RS-232 commands to control the unit.
- 5 DC 24V Port:** Plug the 24V DC power adapter into this port and connect it to an AC wall outlet for power.
- 6 LINE IN Port:** Connect to the analog stereo output of a device such as an audio player or PC.
- 7 LINE OUT Port:** Connect to powered speakers or an amplifier for analog stereo audio output.
- 8 Headphone Out Port:** Connect to powered speakers, headphones, or an amplifier for analog stereo audio output.
- 9 PYP Module Slot:** Install a compatible SDM branded module card to expand the output functionality of the unit (for example, adding streaming or recording functions).

Note: When no module card is installed, this slot should always be covered with a blank cover plate.

Module Card Installation

To install this module card into your unit, it must have at least one available CYP Module Slot.

- (1) Prior to installation, power the unit completely off.

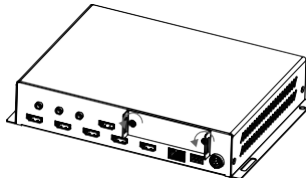

- (2) Remove the dummy faceplate that is covering the card module slot by unscrewing both screws.

Note: Be sure to store the dummy faceplate, and its screws, somewhere safe, in case you need to use them again later.

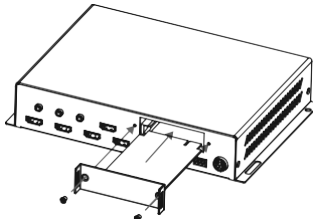

- (3) Align the card with the guiderails to each side of the module slot and gently slide the module card into the slot until its faceplate is flush with the back of the unit.

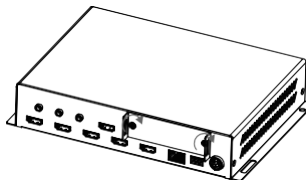

- (4) Secure the module to the unit by using the supplied screws.
- (5) The unit may now be powered back on. The card's power LED will light up to indicate it is receiving power. In most cases, the card will be automatically detected by the unit and be available for use.

Card Removal

- (1) Prior to removal, power the unit completely off.

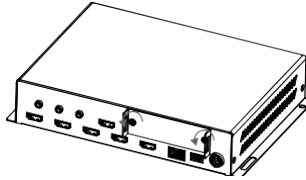

- (2) Completely unscrew both screws.

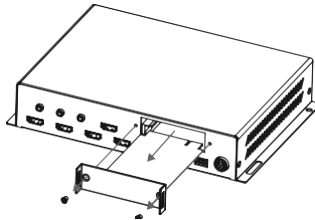

- (3) Gently pull the card straight out of the module slot, using the provided handles.

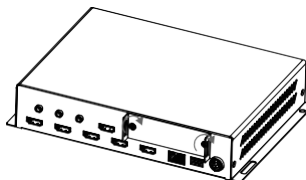

- (4) Cover the module slot with a dummy faceplate and tighten both screws.
- (5) The unit may now be powered back on.

Serial Pinout and Defaults

Serial Port Default Settings	
Baud Rate	19200
Data Bits	8
Parity Bits	None
Stop Bits	1
Flow Control	None

3-pin Terminal Block

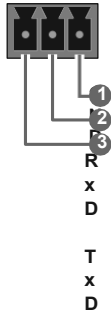

OSD Menu

All functions of this unit can be controlled by using the OSD (On Screen Display) which is activated by pressing the MENU button on the front of the unit. Use the + (PLUS), - (MINUS), and ENTER buttons to navigate the OSD menu. Press the MENU button to back out of any menu item and then press it again to close the menu.

MAIN MENU
Video Mode
Window Layout
Picture
Audio
Input EDID
HDCP Mode
Output Resolution
OSD Settings
Logo Settings
Ethernet Control
Preset
Setup
Information

The individual functions of the OSD will be introduced in the following section. Items marked in BOLD are the factory default settings.

VIDEO MODE	
2ND LEVEL	3RD LEVEL
Video Mode	Matrix
	PiP
	PoP
	QUAD
	Preset 1
	Preset 2
	Preset 3
	Preset 4
PiP/PoP/Quad/Preset Mode	
WIN 1 Source	In 1~4 (IN 1)
WIN 2 Source	In 1~4 (IN 2)
WIN 3 Source	In 1~4 (IN 3)
8.3WIN 4 Source	In 1~4 (IN 4)
Matrix Mode	
OUT A Source	In 1~4 (IN 1)
OUT B Source	In 1~4 (IN 2)

- 1) **Video Mode:** Select the preferred operation mode of the unit.
Note: The selected mode will change some of the unit's available features.
- 2) **WIN 1/2/3/4 Source:** Select the source for the specified window in multi- windowing modes (PiP, PoP, Quad, Presets).
- 3) **OUT A/B Source:** Select the source for the specified HDMI output when in Matrix mode.

WINDOW LAYOUT (Matrix Mode)	
2ND LEVEL	3RD LEVEL
Input Select	In 1~4 (IN 1)
Aspect Ratio	FULL
	16:9
	16:10
	4:3
	Best Fit
Mirror	On
	OFF
Border On/Off	On
	OFF
Border Color	Black
	Red
	GREEN
	Blue
	Yellow
	Magenta
	Cyan
	White
	Dark Red
	Dark Green
	Dark Blue
	Dark Yellow
	Dark Magenta
	Dark Cyan
Gray	
Window Reset	NO
	Yes

- 1) **Input Select:** Select the input to modify.
Note: All settings are individually saved, per-input.
- 2) **Aspect Ratio:** Select a fixed aspect ratio for the currently selected window. Selecting the “Full” aspect ratio will stretch the source to fill the output, regardless of original aspect. Selecting “Best Fit” will automatically set the ratio based on the window’s current source resolution.
- 3) **Mirror:** Selecting “On” will flip the currently selected input horizontally.
- 4) **Border On/Off:** Enables or disables the color border around the currently selected input.
- 5) **Border Color:** Select the color to use for the border of the currently selected input.
- 6) **Window Reset:** Reset the current input to its default settings.

WINDOW LAYOUT (PiP/PoP/Quad/Preset Modes)	
2ND LEVEL	3RD LEVEL
Window Select	Win 1~4 (WIN 1)
Window On/Off	ON
	Off
Position X	0~Max H resolution
Position Y	0~Max V resolution
Size Width	1~Max H resolution
Size Height	1~Max V resolution
Priority	1~4 (4)
Aspect Ratio	FULL
	16:9
	16:10
	4:3
	Best Fit
	User
Mirror	On
	OFF
Border On/Off	On
	OFF

WINDOW LAYOUT (PiP/PoP/Quad/Preset Modes)	
2ND LEVEL	3RD LEVEL
Border Color	Black
	Red
	GREEN
	Blue
	Yellow
	Magenta
	Cyan
	White
	Dark Red
	Dark Green
	Dark Blue
	Dark Yellow
	Dark Magenta
	Dark Cyan
	Gray
Window Reset	NO
	Yes

- 1) **Window Select:** Select the window to modify.
Note: All settings are individually saved, per-window/per-mode.
- 2) **Window On/Off:** Enable or disable the currently selected window.
- 3) **Position X/Y:** Set the X and Y coordinate position of the upper left corner of the currently selected window.
- 4) **Size Width/Height:** Set the horizontal and vertical size of the current selected window.
- 5) **Priority:** Select the layer priority of the currently selected window. Priority 1 is at the front and priority 4 is at the back.
- 6) **Aspect Ratio:** Select a fixed aspect ratio for the currently selected window. The aspect ratio will be based on the window's current height. Selecting the "Full" aspect ratio will return the window to the current

mode's default size and shape for that window. Selecting "Best Fit" will automatically set the ratio based on the window's current source resolution.

- 7) **Mirror:** Selecting "On" will flip the currently selected window horizontally.
- 8) **Border On/Off:** Enables or disables the color border around the currently selected window.
- 9) **Border Color:** Select the color to use for the border of the currently selected window.
- 10) **Window Reset:** Reset the current window to its default settings based on the currently selected mode.

PICTURE	
2ND LEVEL	3RD LEVEL
Input Select	IN 1
	In 2
	In 3
	In 4
Contrast	0~100 (75)
Brightness	0~100 (50)
Saturation	0~100 (50)
Hue	0~100 (50)
Sharpness H	0~10 (10)
Sharpness V	0~10 (10)
Reset	NO
	Yes

- 1) **Input Select:** Select the input to modify.
- 2) **Contrast:** Set the overall contrast of the currently selected input.
- 3) **Brightness:** Set the overall brightness of the currently selected input.
- 4) **Saturation:** Set the overall saturation of the currently selected input.
- 5) **Hue:** Set the hue shift of the currently selected input.
- 6) **Sharpness H/V:** Set the amount of sharpness processing to apply to the currently selected input.
- 7) **Reset:** Reset the current input to its default settings.

AUDIO		
2ND LEVEL	3RD LEVEL	4TH LEVEL
Mixer Microphone AGC	AGC On/Off	ON
		Off
	AGC Level	-6 DB
		-12 dB
-18 dB		
Multiview Audio Source	Output A	Window 1~4 (1)
	Output B	Window 1~4 (1)
Output Volume		
Output A	Source	In 1~4 (IN 1)
		Out A Win
		Out B Win
		Line In
		Mic 1~2
		Mixer
	Master Volume	0~100 (80)
	Output Mute	On
		OFF
	In 1 Volume	0~100 (80)
	In 2 Volume	0~100 (80)
	In 3 Volume	0~100 (80)
	In 4 Volume	0~100 (80)
	Line In Volume	0~100 (80)
Mic 1 Volume	[Shows current level]	
Mic 2 Volume	[Shows current level]	
Output B	Same as [Output A]	
Line Out	Same as [Output A]	
Headphone Out	Same as [Output A]	

AUDIO		
2ND LEVEL	3RD LEVEL	4TH LEVEL
Output Mixer		
Output A	In 1	Enable
		DISABLE
	In 2	Enable
		DISABLE
	In 3	Enable
		DISABLE
	In 4	Enable
		DISABLE
	Out A Win or Output A	Enable
		DISABLE
	Out B Win or Output B	Enable
		DISABLE
	Line In	Enable
		DISABLE
	Mic 1	Enable
		DISABLE
	Mic 2	Enable
		DISABLE
Output B	Same as [Output A]	
Line Out	Same as [Output A]	
Headphone Out	Same as [Output A]	

1) **Mixer Microphone AGC:** Controls the mixer's automatic gain control functionality.

Note: These settings are global, across all active mixers.

- **AGC On/Off:** Enable or disable the use of the automatic gain control function.
- **AGC Level:** Set the output volume reduction target when automatic gain control is active (in dB).

Note: The AGC Level reduce noise from audio source, except for microphone source.

- 2) **Multiview Audio Source:** Set the windows to use as the source audio for each output when in a multi-windowing mode and the output source option is selected.
- 3) **Output Volume (Output A, Output B, Line Out, Headphone Out):** Controls the source selection and source volume for each audio output of the unit.
 - **Source:** Select the source to output over the currently selected audio output.
 - **Master Volume:** Set the master output volume for the currently selected audio output.
 - **Output Mute:** Mute or unmute the currently selected audio output.
 - **In 1~4 Volume:** Set the pre-amp volume level for each of the 4 HDMI inputs, as used by the currently selected output.
 - **Line In Volume:** Set the pre-amp volume level for the line in input, as used by the currently selected output.
 - **Mic 1~2 Volume:** Displays the currently set volume levels of both microphone inputs.

Note: Microphone volume can only be controlled via the front panel's dials.

- 4) **Output Mixer (Output A, Output B, Line Out, Headphone Out):** Controls which audio sources to include in the selected output mixer.
 - **In 1~4:** Enable or disable the inclusion of each HDMI audio source.
 - **Out A~B Win/Output A~B:** Enable or disable the inclusion of the multi-windowing output selection (multiview modes), or output (matrix mode).
 - **Line In:** Enable or disable the inclusion of the line in audio source.
 - **Mic 1~2:** Enable or disable the inclusion of each microphone audio source.

INPUT EDID	
2ND LEVEL	3RD LEVEL
EDID Mode	ALL
	Appoint
All EDID	FHD 2CH
	4K UHD 2CH
	4K UHD+ 2CH
	Sink OUT A
	Sink OUT B
	User 1~4
IN 1 EDID	Same as [All EDID]
IN 2 EDID	Same as [All EDID]
IN 3 EDID	Same as [All EDID]
IN 4 EDID	Same as [All EDID]
User 1 Update	NO
	Yes
User 2 Update	NO
	Yes
User 3 Update	NO
	Yes
User 4 Update	NO
	Yes

- 1) **EDID Mode:** Select how to assign EDIDs to the unit's inputs. Selecting "Appoint" allows for a different EDID to be assigned to each input, selecting "All" allows for a single EDID to be assigned to all inputs.
- 2) **All EDID:** Select the EDID to assign to all inputs.
Note: Only available in the "All" EDID Mode.
- 3) **In 1~4 EDID:** Select the EDID to assign to the specified input.
Note: Only available in the "Appoint" EDID Mode.

- 4) **User 1~4 EDID:** To update any of the unit's 4 User EDIDs via USB, select "Yes" next to the appropriate User EDID and then insert a USB stick containing the new EDID into the Service port. The upload will occur immediately.

Note: The USB stick must contain, in the root directory, a compatible and properly named (EDID_User_.BIN) EDID file.*

HDCP MODE	
2ND LEVEL	3RD LEVEL
In 1~4	HDCP Support Off
	REFER TO SOURCE
	Refer to Display
HDCP Status	
OUT A	[Current HDCP status display]
OUT B	
Win 1	
Win 2	
Win 3	
Win 4	

- 1) **In 1~4:** Select the HDCP behavior for each input.
- **HDCP Support Off:** Completely disables support for HDCP on that input.
 - **Refer to Source:** Makes the input port support the same HDCP version as required by the connected source.
 - **Refer to Display:** Makes the input support the HDCP version of the currently connected displays.
- 2) **HDCP Status:** Displays the current HDCP status of all sources and outputs.

OUTPUT RESOLUTION	
2ND LEVEL	
640×480p59	1920×1080p25
480p60	1920×1080p30
576p50	1920×1080p50
800×600p60	1920×1080P60
848×480p60	1920×1200RB
1024×768p60	3840×2160p24
1280×720p50	3840×2160p25
1280×720p60	3840×2160p30
1280×768p60	4K p24 (DCI)
1280×800p60	4K p25 (DCI)
1280×960p60	4K p30 (DCI)
1280×1024p60	4K p50 (DCI)
1360×768p60	4K p59 (DCI)
1366×768p60	4K p60 (DCI)
1400×1050p60	3840×2160p50
1440×900p60	3840×2160p59
1600×900p60RB	3840×2160p60
1600×1200p60	Native OUT A
1680×1050p60	Native OUT B
1920×1080p24	

1) **Output Resolution:** Select the preferred video output resolution.

Note: Both output A & B always share the same resolution selection.

OSD SETTINGS	
2ND LEVEL	3RD LEVEL
Menu Position	TOP LEFT
	Top Right
	Bottom Right
	Bottom Left
	Center
Menu Timeout	Off
	5~60 (10)
Info. Timeout	Off
	5~60 (5)
Info. Display	ON
	Off
Transparency	OFF
	1~10
Background	Black
	GRAY
	Blue

- 1) **Menu Position:** Set the position of the OSD menu on the output.
- 2) **Menu Timeout:** Set the length of time, in seconds, that the OSD menu will continue to be displayed if there is no user input or disable the timeout completely.
- 3) **Info. Timeout:** Set the length of time, in seconds, that the informational OSD will be displayed after a signal or source change or disable the timeout completely.
- 4) **Info. Display:** Enable or disable the informational OSD.
- 5) **Transparency:** Set the transparency level of the background of the OSD menu.
- 6) **Background:** Set the color of the background of the OSD menu.

LOGO SETTINGS	
2ND LEVEL	3RD LEVEL
Logo On/Off	On
	OFF
Position X	0~100 (10)
Position Y	0~100 (10)
Load Default Logo	NO
	Yes
Logo Update	NO
	Yes

- 1) **Logo On/Off:** Enable or disable displaying the logo graphic.
- 2) **Position X/Y:** Sets the position of the logo's upper left corner, within the output. The position values are a relative percentage of the available output resolution.
- 3) **Load Default Logo:** Selecting yes will reset the logo and install a default test image.

Note: The reset process can take a few moments. Progress information will be displayed on the OSD while the default logo is being installed. The unit will automatically reboot when it is finished.

- 4) **Logo Update:** To upload a graphic logo via USB, select "Yes" and then insert a USB stick containing the new logo graphic file (8-bit *.BMP format, 960×540 max resolution) into the Service port. The upload will occur immediately.

Note: The USB stick must contain, in the root directory, a compatible and properly named (Logo_User_.BMP) graphic file.*

ETHERNET CONTROL	
2ND LEVEL	3RD LEVEL
IP Mode	Static
	DHCP
Static IP Config	
IP Address	x.x.x.x (192.168.1.50)
Subnet Mask	x.x.x.x (255.255.255.0)
Gateway	x.x.x.x (192.168.1.254)
Link Status	
IP Mode	[Current IP Mode]
IP Address	[Current Network Info]
Subnet Mask	
Gateway	
MAC Addr	[Unit's MAC Address]

- 1) **IP Mode:** Set the unit's IP address mode to Static or DHCP.
- 2) **Static IP Config:** When the unit is in Static IP mode the IP address netmask and gateway addresses may be manually set here. Changes will occur immediately.
Note: Only editable in Static IP mode.
- 3) **Link Status:** Displays the unit's current IP configuration and the unit's MAC address.

PRESET	
2ND LEVEL	3RD LEVEL
Save	PRESET 1
	Preset 2
	Preset 3
	Preset 4
Recall	PRESET 1
	Preset 2
	Preset 3
	Preset 4

- 1) **Save Preset 1~4:** Select a preset and then press the “ENTER” button to store the unit’s current video window configuration to the currently selected preset.
- 2) **Recall Preset 1~4:** Select a preset and then press the “ENTER” button to activate the currently selected preset.

SETUP	
2ND LEVEL	3RD LEVEL
Auto Sync Off	ALWAYS ON
	5 sec.
	10 sec.
	15 sec.
	30 sec.
	1 min.
	1.5 min.
	2 min.
	2.5 min.
	3 min.
	5 min.
10 min.	
Firmware Update	NO
	Yes
User EDID Reset	NO
	Yes
Factory Reset	NO
	Yes

- 1) **Auto Sync Off:** Set the amount of time to continue outputting sync with a black screen if there are no live sources and no operations have been executed on the unit. Setting this to “Always On” forces the unit to always output sync.
- 2) **Firmware Update:** To update the firmware via USB, select “Yes” and then insert a USB stick containing the new firmware into the Service port. The upload will occur immediately.
Note: The USB stick must contain, in the root directory, a compatible and properly named (.BIN) firmware file.*
- 3) **User EDID Reset:** Select “Yes” to reset the unit’s User EDIDs to their factory default states.
- 4) **Factory Reset:** Select “Yes” to reset the unit to its factory default state. After the reset is complete, the unit will reboot automatically.

INFORMATION	
2ND LEVEL	3RD LEVEL
IN 1	[Current Input Resolutions & HDCP]
IN 2	
IN 3	
IN 4	
OUT A	[Current Output Resolution & HDCP]
OUT B	
Video Mode	[Current Mode]
Sink A Native	[Native resolutions as reported by EDID]
Sink B Native	
Main Firmware	[Current Firmware Versions]
Module Firmware	
Module Type	[Current Type of Module]

- 1) **Information:** Shows the currently detected details for all inputs and both outputs as well as listing the status of a few critical system settings and relevant firmware versions.

WebGUI Control

• Device Discovery

Please obtain the “Device Discovery” software from your authorized dealer and save it in a directory where you can easily find it.

Connect the unit and your PC/Laptop to the same active network and execute the “Device Discovery” software. Click on “Find Devices on Internet” and a list of devices connected to the local network will show up indicating their current IP address.

Note: This unit defaults to DHCP mode. The current IP address can be verified via the OSD menu or RS-232 if the Device Discovery software is not available.

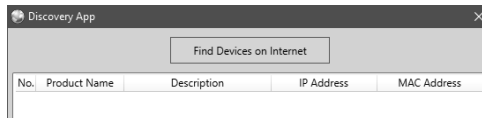

By clicking on one of the listed devices you will be presented with the network details of that particular device.

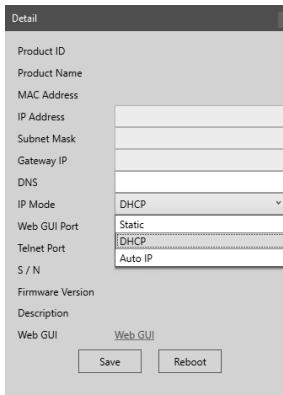

- 1) IP Mode:** If you choose, you can alter the static IP network settings for the device or switch the unit into DHCP mode to automatically obtain proper network settings from a local DHCP server. To switch to DHCP mode, please select DHCP from the IP mode drop-down, then click “Save” followed by “Reboot”.
- 2) WebGUI Hotkey:** Once you are satisfied with the network settings, you may use them to connect via Telnet or WebGUI. The network information window provides a convenient link to launch the WebGUI directly.

- **WebGUI Overview**

After connecting to the WebGUI's address in a web browser, the login screen will appear. Please enter the appropriate username and password then click "Submit" to log in.

Note: The default username and password is "admin".



On the left side of the browser, you will see the following menu tabs where all primary functions of the unit are controllable via the built in WebGUI. The individual functions will be introduced in the following sections.

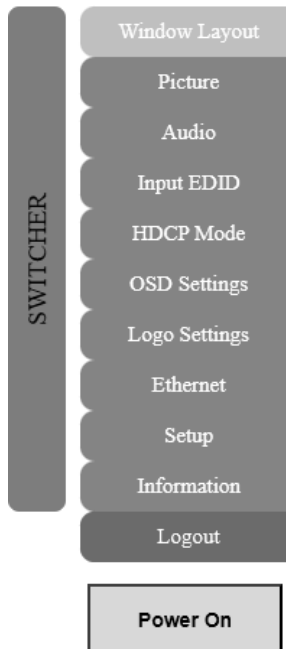

Clicking the red "Logout" tab will automatically log the currently connected user out of the WebGUI and return to login page. Clicking on the "Power" button will toggle the unit's current power state between on (green) and stand-by (red).

1.2.1 Upper Tab Windows

This upper section of the web interface is visible on every tab and provides control over the unit's operational mode, source selection, and output resolution as well as containing basic information about the currently connected source and display devices.

The screenshot shows three panels: Source, Display, and Video Mode. The Source panel has four input fields: Input 1 (3840x2160P60), Input 2 (3840x2160P60), Input 3 (No Signal), and Input 4 (No Signal). The Display panel has a Resolution dropdown (1920x1080p60) and two Sink A/B Native fields (both 3840x2160P60). The Video Mode panel has a Video Mode dropdown (Quad), four Win 1-4 dropdowns (IN 1-4), and two Out A/B dropdowns (IN 1).

- 1) **Source:** This section displays the currently detected resolution for the sources connected to each input.
- 2) **Display:**
 - **Resolution:** Use the dropdown to select the preferred output resolution for the unit.
Note: Both output A & B always share the same resolution selection.
 - **Sink A/B Native:** Displays the native resolution of both connected displays as reported by their respective EDIDs.
- 3) **Video Mode:**
 - **Video Mode:** Use the dropdown to select the unit's operational mode. Available options are Matrix, PiP, PoP, Quad, and Presets 1~4.
Note: Switching between video modes will cause the output to briefly go to black, but audio output will not be affected if the selected audio source is the same in both modes.
 - **Win 1~4:** Select the video source to use in each window of a multi-window mode (PiP/PoP/Quad/Preset).
Note: Only available when a multi-window mode is active.
 - **Out A~B:** Select the video source for each output in Matrix mode.
Note: Only available when Matrix mode is active. The SDM branded Module Cards' A/V source follow output A.

1.2.2 Window Layout Tab

This tab provides control over the position, size, aspect, priority, and other settings of each window in multi-viewer modes. A graphical representation of the layout is also provided. When the unit is in Matrix mode, only a limited selection of controls is available.

Note: Only the information from the currently selected window/input is displayed. A window's position and size cannot exceed the current output resolution.

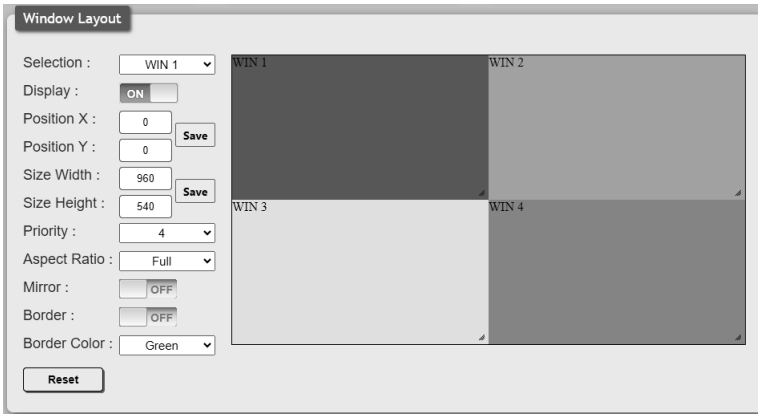

- 1) Selection:** In multi-windowing modes, use the dropdown to select the window to modify. In Matrix mode select the input to modify.
Note: Changes made while a “Preset” video mode is selected will automatically be applied and saved to that preset.
- 2) Display:** Enable or disable the currently selected window.
Note: Not available in Matrix mode.
- 3) Position X/Y:** Set the X and Y coordinate position of the upper left corner of the currently selected window. Click on the “Save” button, after making changes, to make them active.
Note: Not available in Matrix mode.
- 4) Size Width/Height:** Set the horizontal and vertical size of the currently selected window. Click on the “Save” button, after making changes, to make them active.
Note: Not available in Matrix mode.
- 5) Priority:** Select the layer priority of the currently selected window. Priority 1 is at the front and priority 4 is at the back.
Note: Not available in Matrix mode.

6) Aspect Ratio: Use the dropdown to select a fixed aspect ratio for the currently selected window or input. Available options are: Full, 16:9, 16:10, 4:3, Best Fit, and User. In multi-windowing modes the ratio will be based on the window's current height. Selecting the "Full" aspect ratio will return the window to the current mode's default size and shape for that window. Selecting "Best Fit" will automatically set the ratio based on the window's current source resolution.

Note: The "User" aspect ratio is not available in Matrix mode.

7) Mirror: Turning this switch on will flip the currently selected window/input horizontally.

8) Border: This switch enables or disables the color border around the currently selected window or input.

9) Border Color: Use the dropdown to select the color to use for the border of the currently selected window/input. Available colors are: Black, red, green, blue, yellow, magenta, cyan, white, dark red, dark green, dark blue, dark yellow, dark magenta, dark cyan, gray.

10) Reset: Reset the current window/input to its default settings based on the currently selected mode.

11) Visual Layout Window: When in a multi-windowing mode, individual windows may be selected, moved and resized simply by clicking and dragging on them in the layout window. To select a window, click on it and the information will be displayed on the left. Click and drag the center of a window to reposition it. Click and drag the bottom right corner of a window to manually resize it. The results of a change will be displayed on the outputs as soon as the mouse button has been released.

Note: Not available in Matrix mode.

1.2.3 Picture Tab

This tab provides controls over each input's contrast, brightness, saturation, hue, and sharpness levels.

Note: All picture settings are per-input.

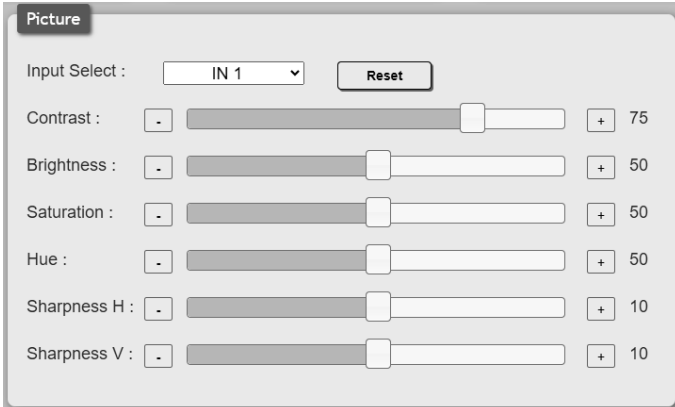

- 1) **Input Select:** Use the dropdown to select the input to modify.
- 2) **Reset:** Reset the current input to its default settings.
- 3) **Contrast:** This slide provides control over the overall contrast of the currently selected source video.
- 4) **Brightness:** This slider provides control over the overall brightness of the currently selected source video.
- 5) **Saturation:** This slider provides control over the overall saturation of the currently selected source video.
- 6) **Hue:** This slider provides control over the hue shift of the currently selected source video.
- 7) **Sharpness H/V:** These sliders provide control over the amount of sharpness processing to apply to the currently selected source video.

Note: Horizontal and vertical processing is independently controlled, providing finer control over the image quality.

1.2.4 Audio Tabs

This tab provides control over the audio behavior of each audio input and output on the unit, including routing selection, input pre-gain, output volume control, automatic gain control, and mixing.

The screenshot displays four control panels for audio settings:

- Mixer Microphone AGC:** AGC Switch is set to ON, and AGC Level is set to -6dB.
- Audio Window in Multiview:** OUT A and OUT B are both set to Window 1.
- Output Volume:** Select is OUT A, Source is IN 1, Master Volume is 80, and Output Mute is OFF. Individual input volumes are: IN 1 (80), IN 2 (80), IN 3 (80), IN 4 (80), LINE IN (80), MIC 1 (19), and MIC 2 (12).
- Output Mixer:** Select is OUT A. All input channels (IN 1-4, OUT A. Win, OUT B. Win, LINE IN, MIC 1, MIC 2) are set to Disabled.

1) **Mixer Microphone AGC:** This section controls the unit's Automatic Gain Control function.

- **AGC Switch:** Enable or disable the automatic gain control function.
- **AGC Level:** Set the output volume reduction target when automatic gain control is active (in dB).

Note: The AGC Level reduces noise from audio sources, except for microphone sources.

2) **Audio Window in Multiview:** Set the windows to use as the source audio for each output when in a multi-windowing mode and the output source option is selected.

Note: No function when in Matrix mode.

3) **Output Volume:** Controls the source selection and source volume for each audio output of the unit.

- **Select:** Use the dropdown to select the audio output to configure.
- **Source:** Select the source to output over the currently selected audio output.
- **Master Volume:** Set the master output volume for the currently selected audio output.
- **Output Mute:** Mute or unmute the currently selected audio output.
- **In Volume 1~4:** Set the pre-amp volume level for each of the 4 HDMI inputs, as used by the currently selected output.
- **Line In Volume:** Set the pre-amp volume level for the line in input, as used by the currently selected output.

- **Mic 1~2 Volume:** Displays the currently set volume levels of both microphone inputs.

Note: Microphone volume can only be controlled via the front panel's dials.

4) Output Mixer: Controls which audio sources to include in the selected output's mixer.

- **Select:** Use the dropdown to select the audio mixer to configure.
- **In 1~4:** Enable or disable the inclusion of each HDMI audio source.
- **Out A~B Win/Output A~B:** Enable or disable the inclusion of the multi-windowing output selection (multiview modes), or output (matrix mode).
- **Line In:** Enable or disable the inclusion of the line in audio source.
- **Mic 1~2:** Enable or disable the inclusion of each microphone audio source.

1.2.5 Input EDID Tab

This unit provides the option of three standard EDIDs, two sink sourced EDIDs and four users uploaded EDIDs that can be assigned to all inputs at the same time, or to each input independently.

Note: In most cases, assigning a new EDID to an input will cause the affected input to briefly blink out while the source adapts to the new information.

The screenshot shows the 'Input EDID' configuration window. It features a title bar 'Input EDID' and a main area with the following controls:

- EDID Mode:** A dropdown menu currently set to 'All'.
- All EDID:** A dropdown menu set to '4K UHD+ 2CH' with a 'Download' button below it.
- IN 1 EDID:** A dropdown menu set to '4K UHD+ 2CH' with a 'Download' button below it.
- IN 2 EDID:** A dropdown menu set to '4K UHD+ 2CH' with a 'Download' button below it.
- IN 3 EDID:** A dropdown menu set to '4K UHD+ 2CH' with a 'Download' button below it.
- IN 4 EDID:** A dropdown menu set to '4K UHD+ 2CH' with a 'Download' button below it.
- User 1 Update:** A 'Choose File' button, the text 'No file chosen', and 'Download' and 'Update' buttons.
- User 2 Update:** A 'Choose File' button, the text 'No file chosen', and 'Download' and 'Update' buttons.
- User 3 Update:** A 'Choose File' button, the text 'No file chosen', and 'Download' and 'Update' buttons.
- User 4 Update:** A 'Choose File' button, the text 'No file chosen', and 'Download' and 'Update' buttons.
- Sink A EDID:** A 'Download' button.
- Sink B EDID:** A 'Download' button.

- 1) EDID Mode:** Use the dropdown to select how to assign EDIDs to the unit's inputs. Selecting "Appoint" allows for a different EDID to be assigned to each input, selecting "All" allows for a single EDID to be assigned to all inputs.
- 2) All EDID:** Select the EDID to assign to all inputs. The new EDID is activated across all inputs as soon as it is selected from the dropdown.
Note: Only available in "All" EDID Mode.
- 3) IN 1~4 EDID:** Select the EDID to assign to the specified input. The new EDID is activated as soon as it is selected from the dropdown. To download a copy of the currently assigned EDID, click on the associated "Download" button.
Note: Only available in "Appoint" EDID Mode.
- 4) User 1~4 Update:** To update any of the unit's 4 User EDIDs, click the "Choose File" button to open the file selection window and then select the EDID file (*.bin format) located on your local PC. After selecting the file, click the "Update" button to begin the EDID upload process. To download a copy of a User EDID, click on the associated "Download" button.
- 5) Sink A~B EDID:** To download a copy of a connected sink's EDID, click on the associated "Download" button.

This unit provides the following 3 default EDIDs:

Unit's default EDIDs	
FHD 2CH	1920×1080p@60Hz (4.95Gbps) & 8-bit color, LPCM 2.0
4K UHD 2CH	3840×2160p@30Hz (10.2Gbps) & Deep Color (8/10/12-bit), LPCM 2.0
4K UHD+ 2CH	3840×2160p@60Hz (18Gbps) & Deep Color (8/10/12-bit), LPCM 2.0

Note: In some rare cases it is possible for custom or external EDIDs to cause compatibility issues with certain sources. If this happens, it is recommended to switch to one of the 3 default EDIDs for maximum compatibility.

1.2.6 HDCP Mode Tab

This tab provides control over the HDCP settings for all inputs and displays the current status for all inputs and outputs.

The screenshot shows two panels. The 'HDCP Mode' panel on the left has four dropdown menus labeled 'Input 1' through 'Input 4', each with 'Refer to Source' selected. The 'HDCP Status' panel on the right has four rows: 'OUT A' and 'OUT B' each with a 'Normal' button; 'Win 1', 'Win 2', 'Win 3', and 'Win 4' each with an empty text input field.

1) **HDCP Mode Input 1~4:** Use the dropdown to select the HDCP behavior for each input.

- **HDCP Support Off:** Completely disables support for HDCP on that input.
- **Refer to Source:** Makes the input port support the same HDCP version as required by the connected source.
- **Refer to Display:** Makes the input support the HDCP version of the currently connected displays.

2) **HDCP Status:** Displays the status for all inputs and outputs.

1.2.7 OSD Settings Tab

This tab provides control over the behavior of the OSD menu and informational display.

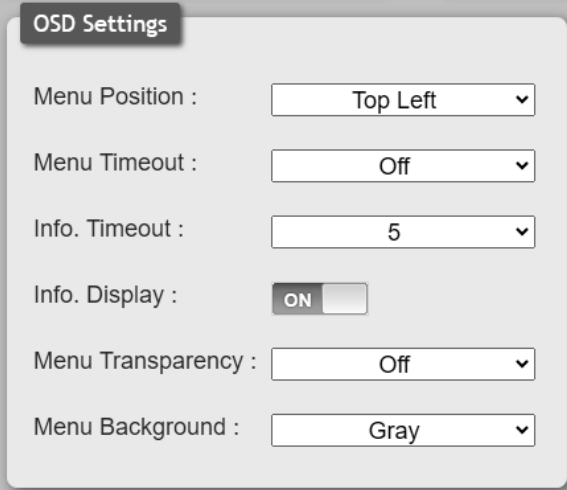

The screenshot shows the OSD Settings tab with the following configurations:

Setting	Value
Menu Position	Top Left
Menu Timeout	Off
Info. Timeout	5
Info. Display	ON
Menu Transparency	Off
Menu Background	Gray

- 1) **Menu Position:** Use the dropdown to set the position of the OSD menu on the output. Available choices are: Top Left, Top Right, Bottom Right, Bottom Left, and Center.
- 2) **Menu Timeout:** Set the length of time, in seconds, that the OSD menu will continue to be displayed if there is no user input or disable the timeout completely.
- 3) **Info. Timeout:** Set the length of time, in seconds, that the informational OSD will be displayed after a signal or source change or disable the timeout completely.
- 4) **Info. Display:** Enable or disable the informational OSD.
- 5) **Menu Transparency:** Set the transparency level of the background of the OSD menu with a range from Off (opaque) to 10 (mostly transparent).
- 6) **Menu background:** Set the color of the background of the OSD menu. The available choices are: Gray, Black, and Blue.

1.2.8 Logo Settings Tab

This tab provides control over the user uploaded logo graphic.

Controls include positioning, uploading a new logo directly from the WebGUI and an option to reset the logo to a built-in default image that can be used for testing.

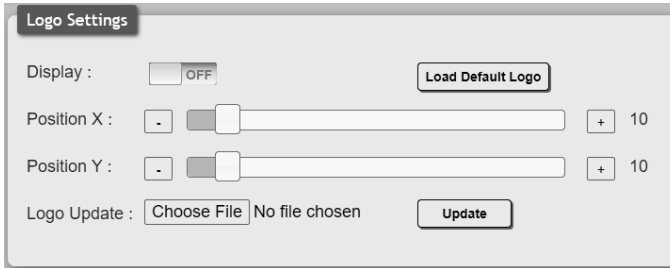

The screenshot shows a web interface titled "Logo Settings". It contains the following elements:

- Display:** A toggle switch currently set to "OFF". To its right is a button labeled "Load Default Logo".
- Position X:** A horizontal slider with a minus sign on the left and a plus sign on the right. The value is currently set to 10.
- Position Y:** A horizontal slider with a minus sign on the left and a plus sign on the right. The value is currently set to 10.
- Logo Update:** A "Choose File" button, followed by the text "No file chosen", and an "Update" button.

- 1) **Display:** Enable or disable displaying the logo graphic.
- 2) **Load Default Logo:** Resets the logo and installs a default test image.

Note: The reset process can take a few moments. Progress information will be displayed on the OSD while the default logo is being installed. The unit will automatically reboot when it is finished.

- 3) **Position X/Y:** Sets the position of the logo's upper left corner, within the output. The position values are a relative percentage of the available output resolution.
- 4) **Logo Update:** To upload a graphic logo, please click the "Choose File" button to open the file selection window and then select the graphic logo file (8-bit *.bmp format, 960×540 max resolution) located on your local PC. After selecting the file, click the "Update" button to upload the logo to the unit.

Note: The upload process can take a while, depending on the size of the logo. Progress information will be displayed on the OSD while the logo is being installed. The unit will automatically reboot when it is finished.

1.2.9 Ethernet Tab

This tab provides controls to change the network settings for the unit. You can manually set the IP address, netmask and gateway address in “Static IP” mode, or you can obtain an IP address automatically by enabling DHCP.

Note: The unit's default Static IP address is 192.168.1.50. If the IP address is changed then the IP address required for WebGUI/Telnet access will also change accordingly.

The screenshot shows the 'Ethernet' configuration page. At the top, there is a tab labeled 'Ethernet'. Below it, the 'IP Mode' is set to 'STATIC'. The 'Static IP Config' section contains three rows of input fields: 'Static IP Address' (192, 168, 1, 50), 'Static Subnet Mask' (255, 255, 255, 0), and 'Static Gateway' (192, 168, 1, 254). A 'Save' button is located to the right of the gateway fields. The 'Link Status' section shows the 'IP Mode' set to 'DHCP', and displays the current 'IP Address' (192, 168, 10, 108), 'Subnet Mask' (255, 255, 255, 0), 'Gateway' (192, 168, 10, 1), and 'MAC Address' (represented by six empty boxes).

- 1) **IP Mode:** Click this button to toggle between the Static IP and DHCP modes. In DHCP mode, the unit will attempt to automatically obtain its IP configuration details from a local DHCP server. In Static mode the unit will use manually assigned IP configuration information.
- 2) **Static IP Config:** When the unit is in Static IP mode the IP address, netmask and gateway addresses may be manually set here. Click “Save” to apply and use the newly entered address.
- 3) **Link Status:** Displays the unit's current IP configuration and the unit's MAC address.

1.2.10 Setup Tab

Provides a way to update firmware and reset various sections within the unit. Control over the unit's Auto Sync Off feature, storing/recalling presets as well as configuring the WebGUI login settings is also provided [here](#).

The image shows two side-by-side panels from a web interface. The left panel, titled 'Setup', contains several configuration options: 'Preset Save' with a dropdown menu set to 'Preset 1' and a 'Save' button; 'Preset Recall' with a dropdown menu set to 'Preset 1' and a 'Recall' button; 'Auto Sync Off' with a dropdown menu set to 'Always On'; 'F/W' with a 'Choose File' button, the text 'No file chosen', and an 'Update' button; 'User EDID' with a 'Reset' button; and 'Factory' with a 'Reset' button. The right panel, titled 'Web Login Settings', contains: 'Username' with a text input field containing 'admin' and a 'Save' button; 'Password' with a masked text input field; 'Confirm Password' with another masked text input field; and 'Timeout' with a text input field containing '0' and a 'Save' button.

- 1) **Preset Save:** Select a preset from the dropdown list and then click the “Save” button to store the unit’s current video window configuration to the currently selected preset.
- 2) **Preset Recall:** Select a preset from the dropdown list and then click the “Recall” button to activate the currently selected preset.
Note: this can also be achieved by selecting a Preset from the Video Mode dropdown at the top of the WebGUI.
- 3) **Auto Sync Off:** Sets the amount of time to continue outputting sync with a black screen if there are no live sources and no operations have been executed on the unit. Setting this to “Always On” forces the unit to always output sync.
- 4) **F/W:** To update the unit’s firmware, click the “Choose File” button to open the file selection window and then select the firmware update file (*.bin format) located on your local PC. After selecting the file, click the “Upgrade” button to begin the firmware update process. After the upgrade is complete, the unit will reboot automatically.
- 5) **User EDID Reset:** Press this button to reset the unit’s User EDIDs to their factory default states.
- 6) **Factory Reset:** Press this button to reset the unit to its factory default state. After the reset is complete, the unit will reboot automatically.
- 7) **Web Login Settings:** WebGUI login settings can be set here.
 - **Username/Password:** To change the login username and password, enter the new information in the spaces provided and press “Save”.
Note: The default username and password is “admin”.
 - **Timeout:** Set the length of time to wait, in minutes, before logging out a user due to inactivity. Setting this to “0” disables the timeout.

1.2.11 Information Tab

This tab displays the unit's serial number as well as the current firmware versions.

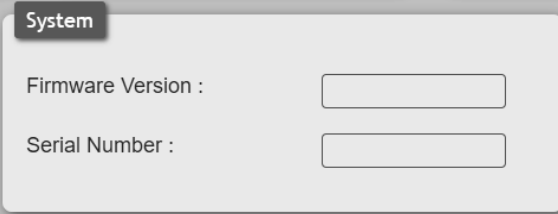

The image shows a screenshot of a user interface window titled "System". Inside the window, there are two rows of text. The first row is "Firmware Version :" followed by a rectangular input field. The second row is "Serial Number :" followed by another rectangular input field. The background of the window is light gray, and the text is in a dark gray font.

1.2.12 Module Tab

The module tab(s) provides additional functions for the SDM branded module card, improving unit integration. The information and setting options will be shown differently based on the module card installed on this unit.

Note: This tab will be visible when a compatible SDM branded module card is installed on the unit.

Telnet Control

Before attempting to use Telnet control, please ensure that both the unit and the PC are connected to the same active networks.

Start your preferred Telnet/Console client or use the built-in client provided by the most modern computer operating systems. After starting the client, connect by using the current IP address of the unit and port 23 (if the communication port number used by the unit has not been changed previously). This will connect us to the unit we wish to control, and commands may now be entered directly.

Note 1: If the IP address of the unit is changed then the IP address required for Telnet access will also change accordingly.

Note 2: This unit defaults to DHCP mode. The current IP address can be verified via the OSD menu or RS-232 if the Device Discovery software is not available. The default communication port is 23.

Serial and Telnet Commands

COMMAND
Description and Parameters
help ↵
Show the full command list.
help N1 ↵
Show details about the specified command. N1 = {Command}
? ↵
Show the full command list.
? N1 ↵
Show details about the specified command. N1 = {Command}
get fw ver ↵
Show the unit's current firmware version.

COMMAND	
Description and Parameters	
get command ver ↵	Show the unit's current command version.
get mac addr ↵	Show the unit's MAC address.
get model name ↵	Show the unit's model name.
get model type ↵	Show the unit's product type.
get update filename ↵	Show the unit's update firmware filename.
set power N1 ↵	Set the unit's power state. Available values for N1 : ON [Power on] OFF [Standby mode]
get power ↵	Show the unit's current power state.
set system reboot ↵	Reboot the unit.
set system usb fw update ↵	Trigger the unit's firmware update state and load the new firmware file via USB.
set uart 1 baudrate N1 ↵	Set the baud rate of the RS-232 port. Available values for N1 : 4800 [4800 baud] 9600 [9600 baud] 19200 [19200 baud] 38400 [38400 baud] 57600 [57600 baud] 115200 [115200 baud]

COMMAND	
Description and Parameters	
get uart 1 baudrate ↵	Show the current baud rate of the RS-232 port.
set ip mode N1 ↵	Set the unit's IP address assignment mode. Available values for N1 : STATIC [Static IP mode] DHCP [DHCP mode]
get ip mode ↵	Show the current IP address assignment mode.
get ipconfig ↵	Show the unit's current IP configuration information.
get ipaddr ↵	Show the unit's current IP address.
get netmask ↵	Show the unit's current netmask.
get gateway ↵	Show the unit's current gateway address.
set static ipaddr N1 ↵	Set the unit's static IP address. N1 = X.X.X.X [X = 0~255, IP address]
get static ipaddr ↵	Show the unit's current static IP address.
set static netmask N1 ↵	Set the unit's static IP address. N1 = X.X.X.X [X = 0~255, Netmask]
get static netmask ↵	Show the unit's current static netmask.

COMMAND	
Description and Parameters	
set static gateway N1 ←	
Set the unit's static IP address.	
N1 = X.X.X.X	[X = 0~255, Gateway address]
get static gateway ←	
Show the unit's current static gateway address.	
set webgui username N1 ←	
Set the WebGUI login username.	
N1 = {Username}	[16 characters max]
get webgui username ←	
Show the current WebGUI login username.	
set webgui password N1 ←	
Set the WebGUI login password.	
N1 = {Password}	[16 characters max]
get webgui password ←	
Show the current WebGUI login password.	
set webgui login timeout N1 ←	
Set the WebGUI inactivity timeout value.	
N1 = 0~240	[Minutes]
get webgui login timeout ←	
Show the current WebGUI inactivity timeout value.	
set telnet login N1 ←	
Enable or disable allowing Telnet logins.	
Available values for N1 :	
ON	[Enabled]
OFF	[Disabled]
get telnet login ←	
Show the current state of Telnet login allowance.	

COMMAND	
Description and Parameters	
set telnet username N1 ↵	
Set the Telnet login username.	
N1 = {Username}	[16 characters max]
get telnet username ↵	
Show the current Telnet login username.	
set telnet password N1 ↵	
Set the Telnet login password.	
N1 = {Password}	[16 characters max]
get telnet password ↵	
Show the current Telnet login password.	
set feedback broadcast N1 ↵	
Enable or disable the broadcast of console command feedback.	
Available values for N1 :	
ON	[Enabled]
OFF	[Disabled]
get feedback broadcast ↵	
Show the current console command feedback broadcast state.	
set window layout mode N1 ↵	
Set the window layout mode.	
Available values for N1 :	
0	[Matrix mode]
1	[PiP mode]
2	[PoP mode]
3	[Quad mode]
4	[Preset 1]
5	[Preset 2]
6	[Preset 3]
7	[Preset 4]
get window layout mode ↵	
Show the window current layout mode.	

COMMAND	
Description and Parameters	
set out N1 route N2↵	
Route the specified input to the specified output in Matrix mode.	
N1 = A~B	[HDMI output port]
N2 = 1~4	[HDMI input port]
<i>Note: Valid in matrix mode only.</i>	
get out N1 route↵	
Show the current input routed to the specified output in Matrix mode.	
N1 = A~B	[HDMI output port]
<i>Note: Valid in matrix mode only.</i>	
set window N1 route N2↵	
Set the input to route to the specified window in multiview.	
N1 = 1~4	[Window number]
N2 = 1~4	[HDMI input port]
<i>Note: Valid in multi-windowing modes only.</i>	
get window N1 route↵	
Show the input currently routed to the specified window in multiview.	
N1 = 1~4	[Window number]
<i>Note: Valid in multi-windowing modes only.</i>	
set window N1 mute N2↵	
Enable or disable the specified window.	
N1 = 1~4	[Window number]
Available values for N1 :	
ON	[Enabled]
OFF	[Disabled]
<i>Note: Valid in multi-windowing modes only.</i>	

COMMAND**Description and Parameters****get window N1 mute**←

Show the visibility status of the specified window.

N1 = 1~4 [Window number]

Note: Valid in multi-windowing modes only.

set window N1 hposition N2←

Set the horizontal position of the specified window.

N1 = 1~4 [Window number]

N2 = 0~{Max res} [Horizontal position]

Note: Valid in multi-windowing modes only.

get window N1 hposition←

Show the current horizontal position of the specified window.

N1 = 1~4 [Window number]

Note: Valid in multi-windowing modes only.

set window N1 vposition N2←

Set the vertical position of the specified window.

N1 = 1~4 [Window number]

N2 = 0~{Max res} [Vertical position]

Note: Valid in multi-windowing modes only.

get window N1 vposition←

Show the current vertical position of the specified window.

N1 = 1~4 [Window number]

Note: Valid in multi-windowing modes only.

set window N1 hsize N2←

Set the horizontal size of the specified window.

N1 = 1~4 [Window number]

N2 = 1~{Max res} [Horizontal size]

Note: Valid in multi-windowing modes only.

COMMAND	
Description and Parameters	
get window N1 hsize ↵	
Show the current horizontal size of the specified window.	
N1 = 1~4	[Window number]
<i>Note: Valid in multi-windowing modes only.</i>	
set window N1 vsize N2 ↵	
Set the vertical size of the specified window.	
N1 = 1~4	[Window number]
N2 = 1~{Max res}	[Vertical size]
<i>Note: Valid in multi-windowing modes only.</i>	
get window N1 vsize ↵	
Show the current vertical size of the specified window.	
N1 = 1~4	[Window number]
<i>Note: Valid in multi-windowing modes only.</i>	
set window N1 priority N2 ↵	
Set the priority of the specified window.	
N1 = 1~4	[Window number]
N2 = 1~4	[Priority]
<i>Note: Valid in multi-windowing modes only.</i>	
get window N1 priority ↵	
Show the current priority of the specified window.	
N1 = 1~4	[Window number]
<i>Note: Valid in multi-windowing modes only.</i>	

COMMAND

Description and Parameters

set window N1 aspect N2↵

Set the aspect of the specified window.

N1 = 1~4 [Window number]

Available values for **N2**:

1	[Full]
2	[16:9]
3	[16:10]
4	[4:3]
5	[Best Fit]
6	[User (Multiview only)]

get window N1 aspect↵

Show the current aspect of the specified window.

N1 = 1~4 [Window number]

set window N1 mirror N2↵

Set the mirror mode of the specified window.

N1 = 1~4 [Window number]

Available values for **N2**:

ON	[Enabled]
OFF	[Disabled]

get window N1 mirror↵

Show the current mirror mode of the specified window.

N1 = 1~4 [Window number]

set window N1 border mode N2↵

Set the border mode of the specified window.

N1 = 1~4 [Window number]

Available values for **N2**:

ON	[Enabled]
OFF	[Disabled]

COMMAND

Description and Parameters

get window N1 border mode←

Show the current border mode of the specified window.

N1 = 1~4 [Window number]

set window N1 border color N2←

Set the border color of the specified window.

N1 = 1~4 [Window number]

Available values for **N2**:

1	[Black]
2	[Red]
3	[Green]
4	[Blue]
5	[Yellow]
6	[Magenta]
7	[Cyan]
8	[White]
9	[Dark Red]
10	[Dark Green]
11	[Dark Blue]
12	[Dark Yellow]
13	[Dark Magenta]
14	[Dark Cyan]
15	[Gray]

get window N1 border color←

Show the current border color of the specified window.

N1 = 1~4 [Window number]

set window N1 default←

Reset the specified window to its default values.

N1 = 1~4 [Window number]

COMMAND

Description and Parameters

set audio out N1 mute N2↵

Enable or disable muting the specified audio output.

Available values for **N1**:

A	[HDMI output A]
B	[HDMI output B]
C	[Line output]
D	[Headphone output]

Available values for **N2**:

ON	[Muted]
OFF	[Unmuted]

get audio out N1 mute↵

Show the current mute state of the specified output.

Available values for **N1**:

A	[HDMI output A]
B	[HDMI output B]
C	[Line output]
D	[Headphone output]

set audio out N1 route N2↵

Route the specified audio input to the specified audio output.

Available values for **N1**:

A	[HDMI output A]
B	[HDMI output B]
C	[Line output]
D	[Headphone output]

Available values for **N2**:

1	[HDMI input 1]
2	[HDMI input 2]
3	[HDMI input 3]
4	[HDMI input 4]
5	[HDMI output A]
6	[HDMI output B]
7	[Line in]
8	[Microphone 1]
9	[Microphone 2]
10	[Mixer]

COMMAND

Description and Parameters

get audio out N1 route←

Show the current audio input routed to the specified audio output.

Available values for **N1**:

A	[HDMI output A]
B	[HDMI output B]
C	[Line output]
D	[Headphone output]

set audio out N1 volume N2←

Set the volume level of the specified output's audio.

Available values for **N1**:

A	[HDMI output A]
B	[HDMI output B]
C	[Line output]
D	[Headphone output]

N2 = 0~100 [Volume level]

get audio out N1 volume←

Show the current volume level of the specified output's audio.

Available values for **N1**:

A	[HDMI output A]
B	[HDMI output B]
C	[Line output]
D	[Headphone output]

set audio agc in N1 mode N2←

Enable or disable automatic gain control for the specified output.

Available values for **N1**:

A	[HDMI output A]
B	[HDMI output B]
C	[Line output]
D	[Headphone output]

Available values for **N2**:

ON	[Enabled]
OFF	[Disabled]

COMMAND

Description and Parameters

get audio agc in N1 mode↵

Show the current automatic gain control state for the specified output.

Available values for **N1**:

A	[HDMI output A]
B	[HDMI output B]
C	[Line output]
D	[Headphone output]

set audio agc in N1 level N2↵

Set the automatic gain control target for the specified output.

Available values for **N1**:

A	[HDMI output A]
B	[HDMI output B]
C	[Line output]
D	[Headphone output]

Available values for **N2**:

1	[-6 dB from normal]
2	[-12 dB from normal]
3	[-18 dB from normal]

get audio agc in N1 level↵

Show the current automatic gain control target for the specified output.

Available values for **N1**:

A	[HDMI output A]
B	[HDMI output B]
C	[Line output]
D	[Headphone output]

set audio mixer out N1 source N2 N3↵

Enable or disable using the specified input source in the mixer assigned to the specified output.

Available values for **N1**:

A	[HDMI output A's mixer]
B	[HDMI output B's mixer]
C	[Line output's mixer]
D	[Headphone output's mixer]

COMMAND

Description and Parameters

Available values for **N2**:

1	[HDMI input 1]
2	[HDMI input 2]
3	[HDMI input 3]
4	[HDMI input 4]
5	[HDMI output A]
6	[HDMI output B]
7	[Line in]
8	[Microphone 1]
9	[Microphone 2]

Available values for **N3**:

ON	[Enabled]
OFF	[Disabled]

get audio mixer out N1 source N2←

Show the inclusion status of the specified input source in the mixer currently assigned to the specified output.

Available values for **N1**:

A	[HDMI output A's mixer]
B	[HDMI output B's mixer]
C	[Line output's mixer]
D	[Headphone output's mixer]

Available values for **N2**:

1	[HDMI input 1]
2	[HDMI input 2]
3	[HDMI input 3]
4	[HDMI input 4]
5	[HDMI output A]
6	[HDMI output B]
7	[Line in]
8	[Microphone 1]
9	[Microphone 2]

COMMAND

Description and Parameters

set audio mixer out N1 source N2 volume N3↵

Set the volume level of the specified input source in the mixer assigned to the specified output.

Available values for **N1**:

A	[HDMI output A's mixer]
B	[HDMI output B's mixer]
C	[Line output's mixer]
D	[Headphone output's mixer]

Available values for **N2**:

1	[HDMI input 1]
2	[HDMI input 2]
3	[HDMI input 3]
4	[HDMI input 4]
5	[HDMI output A]
6	[HDMI output B]
7	[Line in]
8	[Microphone 1]
9	[Microphone 2]

N3 = 0~100 [Volume level]

get audio mixer out N1 source N2 volume↵

Show the current volume level of the specified input source in the mixer currently assigned to the specified output.

Available values for **N1**:

A	[HDMI output A's mixer]
B	[HDMI output B's mixer]
C	[Line output's mixer]
D	[Headphone output's mixer]

Available values for **N2**:

1	[HDMI input 1]
2	[HDMI input 2]
3	[HDMI input 3]
4	[HDMI input 4]
5	[HDMI output A]
6	[HDMI output B]
7	[Line in]
8	[Microphone 1]
9	[Microphone 2]

COMMAND

Description and Parameters

set all in edid mode N1↵

Select the EDID management mode to use (All or Independent) for all inputs.

Available values for N1:

1	[All mode]
2	[Appoint mode]

get all in edid mode↵

Show the current EDID management mode used by all inputs.

set all in edid N1↵

Set the EDID to use when the “All” EDID mode is active.

Available values for N1:

1	[FHD 2-Channel]
2	[4K UHD 2-Channel]
3	[4K UHD+ 2-Channel]
7	[User 1]
8	[User 2]
9	[User 3]
10	[User 4]
15	[Sink A]
16	[Sink B]

get all in edid↵

Show the current EDID used by the “All” EDID mode.

set in N1 edid N2↵

Set the EDID to use on the specified input.

N1 = 1~4 [HDMI input port]

Available values for N2:

1	[FHD 2-Channel]
2	[4K UHD 2-Channel]
3	[4K UHD+ 2-Channel]
7	[User 1]
8	[User 2]
9	[User 3]
10	[User 4]
15	[Sink A]
16	[Sink B]

COMMAND	
Description and Parameters	
get in N1 edid ↵	
Show the EDID currently being used on the specified input.	
N1 = 1~4	[HDMI input port]
set user N1 edid update ↵	
Upload a new EDID, from a USB thumb drive, for use as the specified User EDID.	
N1 = 1~4	[User EDID number]
set in N1 hdcp mode N2 ↵	
Set the HDCP behavior of the specified input.	
N1 = 1~4	[HDMI input port]
Available values for N2 :	
0	[HDCP off]
1	[Refer to Source]
2	[Refer to Display]
get in N1 hdcp mode ↵	
Show the current HDCP behavior used by the specified input.	
N1 = 1~4	[HDMI input port]

COMMAND

Description and Parameters

set out A timing N2[←]

Set the output resolution to use for both outputs.

Available values for **N1**:

0	[640x480p59]
1	[480p60]
2	[576p50]
3	[800x600p60]
4	[848x480p60]
5	[1024x768p60]
6	[1280x720p50]
7	[1280x720p60]
8	[1280x768p60]
9	[1280x800P60]
10	[1280x960p60]
11	[1280x1024p60]
12	[1360x768P60]
13	[1366x768p60]
14	[1400x1050p60]
15	[1440x900p60]
16	[1600x900p60rb]
17	[1600x1200p60]
18	[1680x1050p60]
19	[1920x1080p24]
20	[1920x1080p25]
21	[1920x1080p30]
22	[1920x1080p50]
23	[1920x1080p60]
24	[1920x1200p60rb]
25	[2048x1152p60rb]
26	[3840x2160p24]
27	[3840x2160p25]
28	[3840x2160p30]
29	[4K p24 DCI]
30	[4K p25 DCI]
31	[4K p30 DCI]
32	[4K p50 DCI]
33	[4K p59 DCI]
34	[4K p60 DCI]
35	[3840x2160p50]
36	[3840x2160p59]

COMMAND	
Description and Parameters	
37	[3840x2160p60]
38	[Native OUT A]
39	[Native OUT B]
get out A timing ↵	
Show the current resolution used by both outputs.	
set out A osd banner location N1 ↵	
Set the OSD banner location.	
Available values for N1 :	
0	[Top Left]
1	[Top Right]
2	[Bottom Right]
3	[Bottom Left]
4	[Center]
get out A osd banner location ↵	
Show the current OSD banner location.	
set out A osd timeout N1 ↵	
Set the OSD menu's timeout value (in seconds).	
Available values for N1 :	
OFF	[Disabled]
5~60	[Timeout in seconds]
get out A osd timeout ↵	
Show the current OSD menu's timeout value.	
set out A osd info display N1 ↵	
Enable or disable the info OSD.	
Available values for N1 :	
ON	[Enabled]
OFF	[Disabled]
get out A osd info display ↵	
Show the current info OSD state.	

COMMAND	
Description and Parameters	
set out A osd logo hposition N1 ↵	
Set the horizontal position of the graphical logo overlay.	
N1 = 0~100	[Horizontal position]
get out A osd logo hposition ↵	
Show the current horizontal position of the graphical logo overlay.	
set out A osd logo vposition N1 ↵	
Set the vertical position of the graphical logo overlay.	
N1 = 0~100	[Vertical position]
get out A osd logo vposition ↵	
Show the current vertical position of the graphical logo overlay.	
set out osd logo default ↵	
Reset the unit's OSD logo to the factory default.	
set system usb osd logo update ↵	
Trigger the unit to enter its OSD logo update state and load a new OSD logo file from USB.	
set current route to preset N1 ↵	
Save all current routing assignments to the specified preset.	
N1 = 1~4	[Preset number]
set route preset N1 ↵	
Activate the routing assignments saved in the specified preset.	
N1 = 1~4	[Preset number]

COMMAND																									
Description and Parameters																									
set out A auto sync off N1 ↵	<p>Enable or disable the Auto Sync Off function on both outputs and set the timeout length.</p> <p>Available values for N1:</p> <table> <tr><td>0</td><td>[Always on]</td></tr> <tr><td>1</td><td>[5 seconds]</td></tr> <tr><td>2</td><td>[10 seconds]</td></tr> <tr><td>3</td><td>[15 seconds]</td></tr> <tr><td>4</td><td>[30 seconds]</td></tr> <tr><td>5</td><td>[1 minute]</td></tr> <tr><td>6</td><td>[1.5 minutes]</td></tr> <tr><td>7</td><td>[2 minutes]</td></tr> <tr><td>8</td><td>[2.5 minutes]</td></tr> <tr><td>9</td><td>[3 minutes]</td></tr> <tr><td>10</td><td>[5 minutes]</td></tr> <tr><td>11</td><td>[10 minutes]</td></tr> </table>	0	[Always on]	1	[5 seconds]	2	[10 seconds]	3	[15 seconds]	4	[30 seconds]	5	[1 minute]	6	[1.5 minutes]	7	[2 minutes]	8	[2.5 minutes]	9	[3 minutes]	10	[5 minutes]	11	[10 minutes]
0	[Always on]																								
1	[5 seconds]																								
2	[10 seconds]																								
3	[15 seconds]																								
4	[30 seconds]																								
5	[1 minute]																								
6	[1.5 minutes]																								
7	[2 minutes]																								
8	[2.5 minutes]																								
9	[3 minutes]																								
10	[5 minutes]																								
11	[10 minutes]																								
get out A auto sync off ↵	<p>Show the current Auto Sync Off settings for both outputs.</p>																								
set system usb fw update ↵	<p>Initiates the firmware update process via USB.</p>																								
set factory user edid default ↵	<p>Restore the unit's User EDIDs to their factory default settings.</p>																								
set factory ipconfig default ↵	<p>Reset the unit's network settings to the factory defaults.</p>																								
set factory default ↵	<p>Restore the unit's settings, except for User EDIDs, presets, and network settings to their factory default settings.</p>																								

Note: Commands will not be executed unless followed by a carriage return. Commands are not case-sensitive.

CONNECTION DIAGRAM

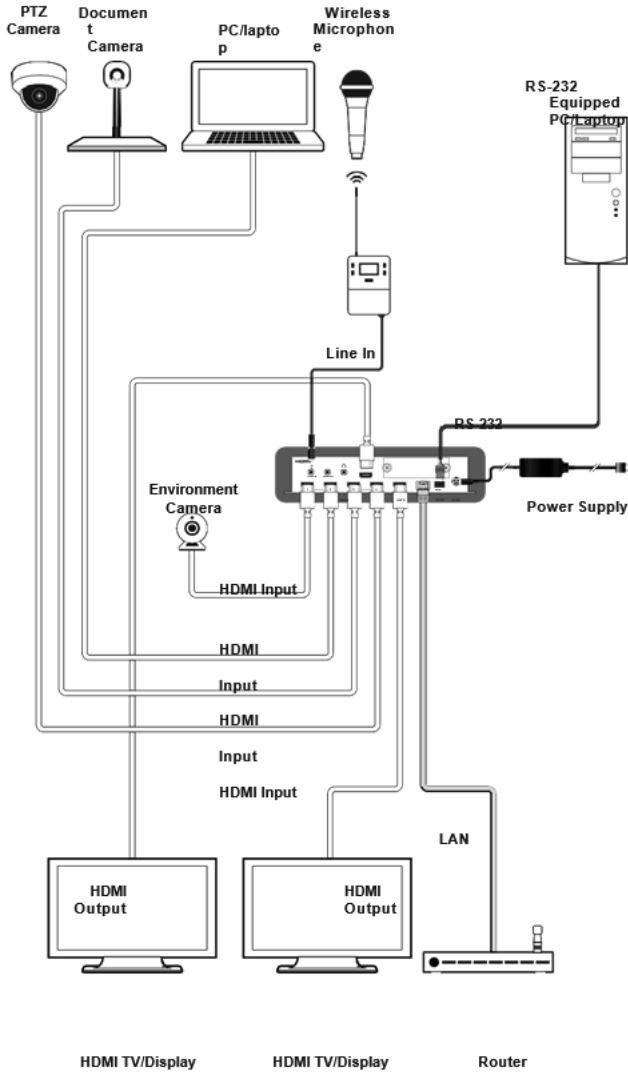

SPECIFICATIONS

Technical Specifications

HDMI Bandwidth	18Gbps
Input Ports	4×HDMI (Type-A) 2×Analog Mono Audio (3.5mm) 1×Analog Stereo Audio (3.5mm)
Output Ports	2×HDMI (Type-A) 2×Analog Stereo Audio (3.5mm)
Control Ports	1×RS-232 (3-pin Terminal Block) 1×IP Control (RJ-45)
Service Port	1×USB 2.0 (Type-A)
Baud Rate	19200
Power Supply	24V/2.7A DC (US/EU standards, CE/FCC/UL certified)
ESD Protection (HBM)	±8kV (Air Discharge) ±4kV (Contact Discharge)
Dimensions (W×H×D)	213.5mm×43mm×158mm [Case Only] 231.5mm×44mm×161mm [All Inclusive]
Weight	1250g
Chassis Material	Metal (Steel)
Chassis Color	Black
Operating Temperature	0°C – 40°C/32°F – 104°F
Storage Temperature	-20°C – 60°C/-4°F – 140°F
Relative Humidity	20 – 90% RH (Non-condensing)
Power Consumption	29W

Video Specifications

Supported Resolutions (Hz)	Input	
	HDMI	HDMI
720×400p@70/85	✓	x
640×480p@60/72/75/85	✓	60Hz
720×480i@60	✓	x
720×480p@60	✓	✓
720×576i@50	✓	x
720×576p@50	✓	✓
800×600p@56/60/72/75/85	✓	60Hz
848×480p@60	✓	x
1024×768p@60/70/75/85	✓	✓
1152×864p@75	✓	x
1280×720p@50/60	✓	✓
1280×768p@60/75/85	✓	60Hz
1280×800p@60/75/85	✓	60Hz
1280×960p@60/85	✓	60Hz
1280×1024p@60/75/85	✓	60Hz
1360×768p@60	✓	✓
1366×768p@60	✓	✓
1400×1050p@60	✓	✓
1440×900p@60/75	✓	60Hz
1600×900p@60RB	✓	✓
1600×1200p@60	✓	✓
1680×1050p@60	✓	✓
1920×1080i@50/60	✓	x
1920×1080p@24/25/30	✓	✓
1920×1080p@50/60	✓	✓

Supported Resolutions (Hz)	Input	
	HDMI	HDMI
1920×1200p@60RB	✓	✓
2560×1440p@60RB	✓	×
2560×1600p@60RB	✓	×
2048×1080p@24/25/30	✓	×
2048×1080p@50/60	✓	×
3840×2160p@24/25/30	✓	✓
3840×2160p@50/60 (4:2:0)	✓	×
3840×2160p@24, HDR10	×	×
3840×2160p@50/60 (4:2:0), HDR10	×	×
3840×2160p@50/60	✓	✓
4096×2160p@24/25/30	✓	✓
4096×2160p@50/60 (4:2:0)	✓	×
4096×2160p@24, HDR10	×	×
4096×2160p@50/60 (4:2:0), HDR10	×	×
4096×2160p@50/60	✓	✓

Audio Specifications

1.2.13 Digital Audio

Multiviewer HDMI Inputs 1~4 / Outputs A~B / Slot	
LPCM	
Max Channels	2 Channels
Sampling Rate (kHz)	48

1.2.14 Analog Audio

Analog Input (Line)	
Max Audio Level	2Vrms
Impedance	20k Ω
Type	Balanced/Unbalanced

Analog Input (Mic 1 & 2)	
Max Audio Level	2Vrms
Impedance	47k Ω
Type	Balanced/Unbalanced

Analog Output (Line)	
Max Audio Level	2Vrms
THD+N	< 0.01dB@0dBFS 1kHz (A-wt)
SNR	> 70dB@0dBFS
Frequency Response	< \pm 3dB@20Hz~20kHz
Crosstalk	< -60dB@10kHz
Impedance	499 Ω
Type	Balanced/Unbalanced

Analog Output (Headphone)	
Max Audio Level	1.7Vrms
THD+N	< 0.04dB@0dBFS 1kHz (A-wt)
SNR	> 70dB@0dBFS
Frequency Response	< \pm 3dB@20Hz~20kHz
Crosstalk	< -60dB@10kHz
Impedance	16 Ω
Type	Balanced/Unbalanced

Cable Specifications

Cable Length	HD	FHD	4K UHD	4K UHD+	8K UHD
High Speed HDMI Cable					
HDMI Input	15m	10m	5m	3m	×
HDMI Output	15m	10m	5m	3m	×

Bandwidth Category Examples:

- **HD Video**

- 720p@60Hz
- HDMI transmission rates lower than 3Gbps
- HD-SDI (SMPTE 292M, 1.485Gbps)

- **FHD Video**

- 1080p@60Hz
- HDMI transmission rates between 3Gbps and 5.3Gbps
- 3G-SDI (SMPTE 424M, 2.970Gbps)
- 4K UHD Video
- 4K@24/25/30Hz (8-bit color) & 4K@50/60Hz (4:2:0, 8-bit color)
- HDMI transmission rates between 5.3Gbps and 10.2Gbps
- 6G-SDI (SMPTE ST 2081, 6Gbps)

- **4K UHD+ Video**

- 1080p@120Hz (10/12-bit HDR)
- 4K@50/60Hz (4:4:4, 8-bit) & 4K@50/60Hz (4:2:0, 10/12-bit HDR)
- HDMI transmission rates are between 10.2Gbps and 18Gbps
- 12G-SDI (SMPTE ST 2082, 12Gbps)

- **8K UHD Video**

- 4K@120Hz (10/12-bit HDR)
- 8K@24/25/30Hz (10/12-bit HDR) & 8K@50/60Hz (4:2:0, 8-bit color)
- HDMI transmission rates between 18Gbps and 48Gbps
- 24G-SDI (SMPTE ST 2083, 24Gbps)

ACRONYMS

ACRONYM	COMPLETE TERM
4K UHD	4K Ultra-High-Definition (10.2Gbps max)
4K UHD⁺	4K Ultra-High-Definition (18Gbps max)
8K UHD	8K Ultra-High-Definition (48Gbps max, without DSC)
8K UHD⁺	8K Ultra-High-Definition (48Gbps max, with DSC)
ADC	Analog-to-Digital Converter
ASCII	American Standard Code for Information Interchange
Cat.5e	Enhanced Category 5 cable
Cat.6	Category 6 cable
Cat.6A	Augmented Category 6 cable
Cat.7	Category 7 cable
DAC	Digital-to-Analog Converter
dB	Decibel
DHCP	Dynamic Host Configuration Protocol
DVI	Digital Visual Interface
EDID	Extended Display Identification Data
GbE	Gigabit Ethernet
Gbps	Gigabits per second
GUI	Graphical User Interface
HDCP	High-bandwidth Digital Content Protection
HDMI	High-Definition Multimedia Interface
HDR	High Dynamic Range
IP	Internet Protocol
kHz	Kilohertz
LAN	Local Area Network
LED	Light-Emitting Diode
LPCM	Linear Pulse-Code Modulation
MHz	Megahertz
OSD	On-Screen Display

ACRONYM	COMPLETE TERM
PiP	Picture in Picture
PoP	Picture outside of Picture
SNR	Signal-to-Noise Ratio
TCP	Transmission Control Protocol
THD+N	Total Harmonic Distortion plus Noise
TMDS	Transition-Minimized Differential Signaling
USB	Universal Serial Bus
VGA	Video Graphics Array
WUXGA (RB)	Widescreen Ultra Extended Graphics Array (Reduced Blanking)
XGA	Extended Graphics Array
Ω	Ohm

For order support, please contact your Distributor or Reseller.

For technical support, check with the our website www.vigillink.com or contact info@vigillink.com



Headquarters
46 Corporate Park #130
Irvine, CA 92606
949-701-4742