

UC-C100-PRO-Z

Crestron Flex Video Conference System Integrator Pro Kit for Zoom Rooms® Software



- *Confferencing integration solution for Zoom Rooms® software*
- *Native Zoom Rooms® touch screen UI provides a consistent, simple user experience with one-touch meeting joins*
- *Complete kit contains a 10.1 in. tabletop touch screen and UC bracket assembly*
- *Network management and provisioning and system alerts through the XiO Cloud® service*
- *Premium-level support with Crestron Flex Care (optional)*
- *Enterprise-grade security – connects and communicates securely over any enterprise or SMB network*
- *Supports up to three video displays (not included)*

The UC-C100-PRO-Z Crestron Flex integrator kit provides a customizable video conference solution for use with Zoom Rooms® software. It supports up to three video displays¹ (not included), up to four cameras (not included), and features a tabletop touch screen and a UC bracket assembly.

Native Zoom Rooms® Software Experience

The UC-C100-PRO-Z system features Zoom Rooms conferencing software that enables audio and video connectivity for easy collaboration and content sharing. It is compatible with Multi-camera, Multi-stream and Intelligent Director functions.

Custom Room Integration

The UC-C100-PRO-Z system provides the essential components needed to design a fully custom video conferencing space using your choice of display devices, cameras, speakers, microphones, and other AV equipment. Any Zoom Rooms software certified USB camera such as the Crestron [IV-CAMHK-12-SLVR-1B](#), [IV-CAM-P12](#) and [IV-CAM-P20](#) and a USB audio conferencing interface (or speakerphone) may be used.

Intuitive User Interface

With a large 10.1 in. (257 mm) capacitive touch screen display, the Crestron® tabletop touch screen ([TS-1070](#)) provides superior conferencing control in meeting rooms, huddle spaces, and executive offices. The touch screen also offers optional control of room lighting, shades, thermostats, and other equipment.²

Simplified Deployment

To simplify installation, the UC Bracket Assembly provides preassembled components on one ready-to-mount bracket. The bracket comes supplied with either a HD-CONV-USB 200 or HD-CONV-USB-300 convertor. The assembly can be mounted on a wall, or it can be attached to the rear of the display device.

Enterprise-Grade Security

Crestron Flex is an enterprise-grade solution that is equipped for mass deployment throughout any sized corporate, university, medical, military, or government facility.

Easy Provisioning and Device Management

The XiO Cloud® service is an IoT cloud-based provisioning service (available separately) that enables installers and IT managers to easily deploy and manage thousands of devices. The XiO Cloud service provides system alerts, network management and provisioning, and the pairing of a control device to the system's UC Engine. System updates are controlled by Windows® software update.

Visit www.crestron.com/xiocloud for additional information.

Premium-Level Support

Crestron Flex Care is an optional subscription service that automatically renews annually, providing 24/7 live remote technical support, an extended five year warranty on Crestron® branded hardware, expedited advance replacements, and a discounted rate for onsite support.

Visit www.crestron.com/flexcare for detailed terms and conditions and additional information.

Deployment Resources

View the [Crestron Flex Pre-Deployment Checklist](#) to help plan your Crestron Flex installation.

UC-C100-PRO-Z

Crestron Flex Video Conference System Integrator Pro Kit for Zoom Rooms® Software

Specifications

Included Components

TS-1070-B-S	10.1 in. (257 mm) tabletop touch screen, black
UC-BRKT-200-PRO-Z-ASSY	UC Bracket Assembly comprised of: <ul style="list-style-type: none">• UC-Engine-Pro: i7 Mini PC with Zoom Rooms video• HDMI® to USB 3.0 converter for content ingest• Mounting hardware
CBL-4K-DP-HD-6	DisplayPort™ to HDMI Cable, 6 ft (1.8 m); secondary display
CBL-CAT5E-7	(2) Ethernet LAN cable for UC Engine, RJ-45-to-RJ-45, black, 7 ft (2.1 m)
CBL-HD-6	HDMI Interface Cable, 6 ft (1.8 m); primary display
CBL-HD-20	HDMI Interface Cable, 20 ft (6.1 m); content sharing
PWE-4803RU	PoE Injector

Tabletop Touch Screen

Touch Screen	10.1 in. (257 mm) diagonal capacitive multi-touch TFT active matrix color LCD, 1920 x 1200 pixels
UI	Zoom Rooms UI plus optional Crestron Smart Graphics® room control UI ²
Ethernet	100/1000 Mbps, autoswitching, autonegotiating, autodiscovery, full/half duplex, TCP/IP, UDP/IP, CIP, DHCP, SSL, TLS, SSH, SFTP (SSH File Transfer Protocol), IEEE 802.1X, SNMP, IPv4 or IPv6, Active Directory® service authentication, HTTPS web browser setup, XiO Cloud® client, IEEE 802.3at compliant
Power over Ethernet	IEEE 802.3at Type 2 compliant PoE+ PD (Powered Device); Normally requests 15 W from an 802.3at Type 2 PSE with LLDP advanced power management; With room scheduling and USB enabled, requests 18 W from an 802.3at Type 2 PSE with LLDP; Requests 30 W (PoE+ Class 4) from an 802.3at Type 2 PSE without LLDP; Requests 15.4 W (PoE Class 0) from an 802.3af (or 802.3at Type 1) PSE

PoE Injector	A PoE injector is included to power the touch screen if network PoE is not available
Construction	Plastic, smooth black finish, edge-to-edge glass with black surround
Dimensions	Height: 5.29 in. (134 mm) Width: 9.63 in. (245 mm) Depth: 4.67 in. (119 mm)
Weight	2.44 lb (1.10 kg)

UC Bracket Assembly

UC Engine Pro	Mini PC, Intel Core® i7 processor, 12th Generation with Windows® 11 IoT Edition OS and 100/1000 Mbps Ethernet connectivity
UC Client	Zoom Rooms software
Management Client	XiO Cloud Service
Content Ingest	HDMI input via HDMI to USB 3.0 converter
Display Output	Up to three displays supported ¹
Display Output Resolution	1080p
Power	100-240VAC, 50/60 Hz adapter (included)
Construction	Metal mounting bracket, black, preassembled with UC Engine and HDMI to USB 3.0 converter
Mounting	Surface wall mount behind the display device, or attach to the rear of the display device via the bolts attaching the display to a VESA® compliant display mount; Bracket includes mounting holes on both side edges, spaced 100, 200, and 300 mm vertically, to allow for attachment to either side of the display mounting plate
Dimensions	Height: 15.00 in. (381 mm) Width: 14.50 in. (368 mm) Depth: 1.87 in. (48 mm) (UC Bracket Assembly with HD-CONV-USB-200) 1.93 in. (49 mm) (UC Bracket Assembly with HD-CONV-USB-300)
Weight	7.7 lb (3.5 kg) (UC Bracket Assembly with HD-CONV-USB-200) 7.95 lb (3.6 kg) (UC Bracket Assembly with HD-CONV-USB-300)

Model

UC-C100-PRO-Z

Crestron Flex Video Conference System Integrator Pro Kit for Zoom Rooms® Software

UC-C100-PRO-Z

Crestron Flex Video Conference System Integrator Pro Kit for Zoom Rooms® Software

Available Accessories

For a list of available accessories, visit the [UC-C100-PRO-Z](#) product page.

Notes:

1. Display must support "Wake on Sync" and "Sleep on No Sync" functionality. Consult the display manufacturer's specifications or internal settings of the specific display.
2. Room control capability (lighting, shades, thermostats, and so forth) requires additional equipment and commissioning to be provided by a Crestron authorized integrator and/or programmer. Additional costs may apply.

The original language version of this document is U.S. English. All other languages are a translation of the original document.

This product may be purchased from select authorized Crestron dealers and distributors. To find a dealer or distributor, please contact the Crestron sales representative for your area. A list of sales representatives is available online at www.crestron.com/How-To-Buy/Find-a-Representative or contact us for additional information by visiting <https://www.crestron.com/contact/our-locations> for your local contact.

This product is covered under the Crestron standard limited warranty. Refer to www.crestron.com/warranty for full details.

The specific patents that cover Crestron products are listed online at patents.crestron.com.

Certain Crestron products contain open source software. For specific information, please visit www.crestron.com/opensource.

Crestron, the Crestron logo, Smart Graphics, and XiO Cloud are either trademarks or registered trademarks of Crestron Electronics, Inc. in the United States and/or other countries. HDMI and the HDMI Logo are either a trademark or registered trademark of HDMI Licensing LLC in the United States and/or other countries. Intel Core is either a trademark or registered trademark of Intel Corporation in the United States and/or other countries. Active Directory and Windows are either trademarks or registered trademarks of Microsoft Corporation in the United States and/or other countries. DisplayPort and VESA are either trademarks or registered trademarks of Video Electronics Standards Association in the United States and/or other countries. Zoom Rooms is either a trademark or registered trademark of Zoom Video Communications, Inc. in the United States and/or other countries. Other trademarks, registered trademarks, and trade names may be used in this document to refer to either the entities claiming the marks and names or their products. Crestron disclaims any proprietary interest in the marks and names of others. Crestron is not responsible for errors in typography or photography.

HDMI

Specifications are subject to change without notice.

©2024 Crestron Electronics, Inc.

Rev 07/17/24

UC-C100-PRO-Z

Crestron Flex Video Conference System Integrator Pro Kit for Zoom Rooms®
Software

Touch Screen (TS-1070-B-S)

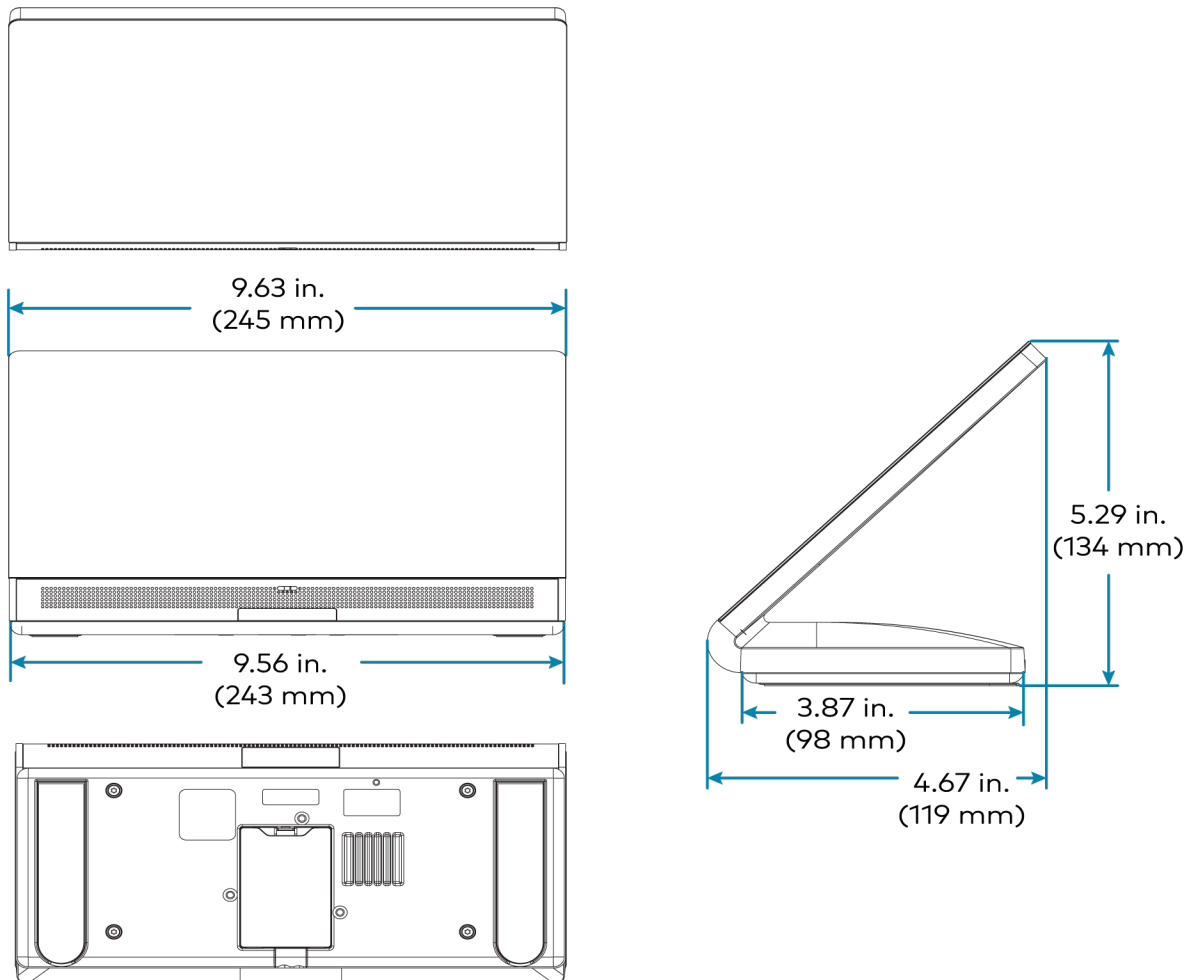

UC-C100-PRO-Z

Crestron Flex Video Conference System Integrator Pro Kit for Zoom Rooms® Software

UC Bracket Assembly with HD-CONV-USB-200

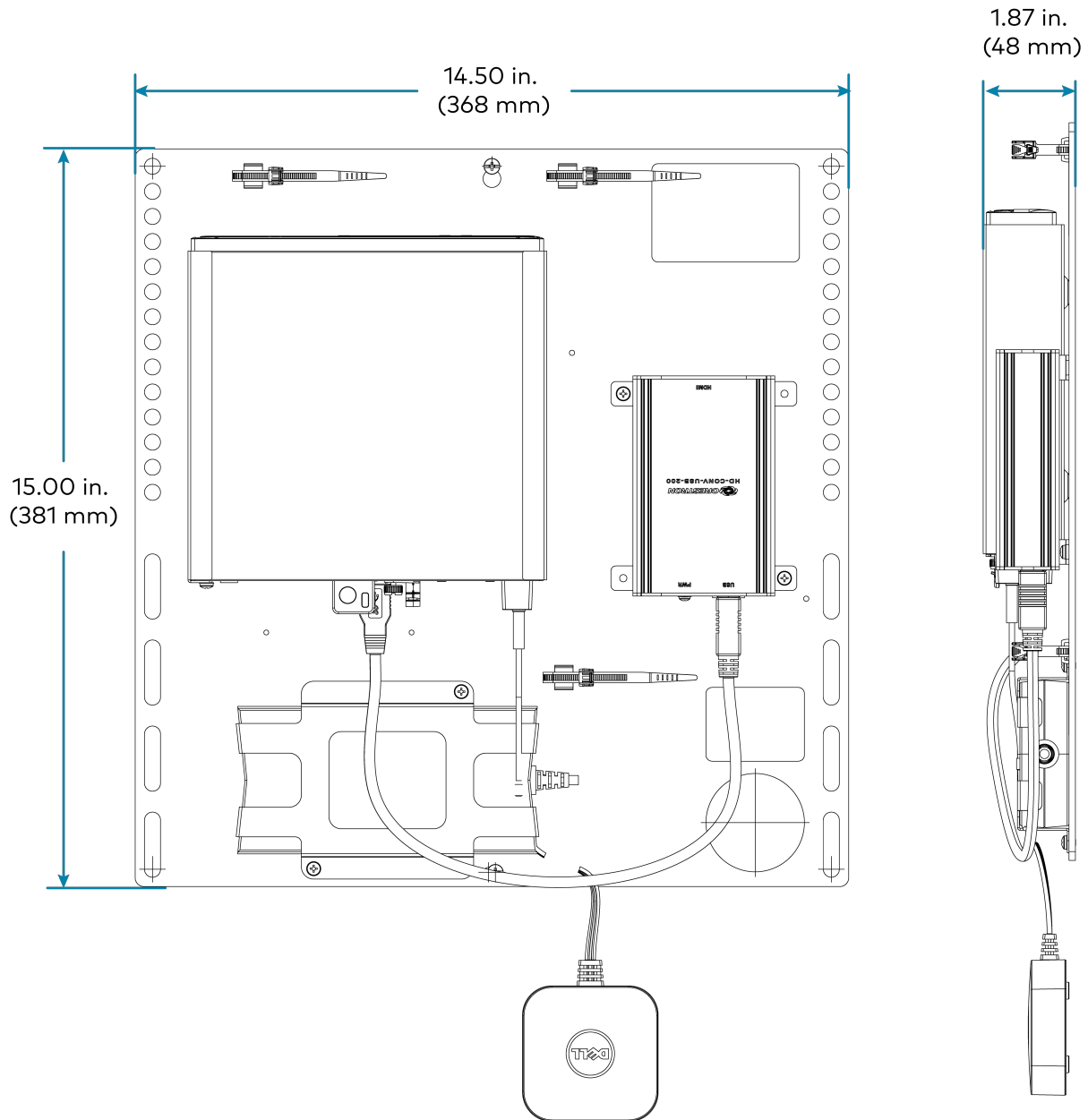

UC-C100-PRO-Z

Crestron Flex Video Conference System Integrator Pro Kit for Zoom Rooms® Software

UC Bracket Assembly with HD-CONV-USB-300

