

Scan this QR code for product information, videos, and assembly assistance.

MOBILE TV STAND



HAVE QUESTIONS?

Monday - Friday from 5:00am - 5:00pm PST



support@mount-it.com



(855) 925-5668



www.mount-it.com

Thank you for choosing Mount-It!

EN  Read the entire instruction manual before you start installation and assembly. If you have any questions regarding any of the instructions or warnings, please contact Mount-It for assistance.

CAUTION: Use with products heavier than the rated weights indicated may result in instability causing possible injury.

- Mounts must be attached as specified in assembly instructions. Improper installation may result in damage or serious personal injury.
- Safety gear and proper tools must be used. This product should only be installed by professionals.
- Make sure that the supporting surface will safely support the combined weight of the equipment and all attached hardware and components.
- Use the mounting screws provided and DO NOT OVER TIGHTEN mounting screws.
- This product contains small items that could be a choking hazard if swallowed. Keep these items away from children.
- This product is intended for indoor use only. Using this product outdoors could lead to product failure and personal injury.

IMPORTANT: Ensure that you have received all parts according to the component checklist prior to installation. If any parts are missing or faulty, telephone Mount-It for a replacement.

MAINTENANCE: Check that the bracket is secure and safe to use at regular intervals (at least every three months).

DE  Bitte vor Beginn der Montage und Zusammenbau das ganze Handbuch durchlesen. Bitte sich mit dem Händler vor Ort bei Fragen zur Anleitung oder Warnungen in Verbindung setzen.

VORSICHT: Bei Verwendung mit Produkten, die das zulässige Gewicht überschreiten, können Schäden oder möglicherweise Verletzungen die Folge sein.

- Halterungen sollen entsprechend den Montageanweisungen angebracht werden. Eine unsachgemäße Montage kann Schäden oder Verletzungen zur Folge haben.
- Sicherheitsausrüstung und geeignete Werkzeuge verwenden. Die Montage des Produktes sollte nur von Fachleuten durchgeführt werden.
- Die tragenden Oberflächen sollten das gesamte Gewicht von Geräten und allen zusätzlichen Bauteilen sicher aushalten können.
- Nur die mitgelieferten Einbauschrauben verwenden und die Schrauben NICHT ZU FEST ANZIEHEN.
- Dieses Produkt enthält Kleinteile, die Erstickungsgefahr beim Verschlucken hervorrufen können. Diese Teile von Kindern fernhalten.
- Dieses Produkt nur in Innenräumen verwenden. Verwendung des Produktes im Außenbereich kann zu Verletzungen und Schäden führen.

WICHTIG: Vor der Montage bitte alle erhaltenen Bauteile mit der Bauteilliste abgleichen. Bei beschädigten oder fehlenden Teilen den Händler vor Ort nach Ersatzteilen fragen.

WARTUNG: Die Halterungsklammer regelmäßig auf Sicherheit und Stabilität prüfen (am besten alle drei Monate).

FR  Lisez entièrement le guide d'utilisateur avant de commencer l'installation et le montage. Si vous avez des questions concernant les instructions ou les avertissements, veuillez contacter votre distributeur local pour une assistance.

ATTENTION: L'utilisation de produits plus lourds que les poids nominaux indiqués peut entraîner une instabilité causant des blessures potentielles.

- Les supports doivent être joints comme spécifié dans les instructions de montage. Une mauvaise installation peut entraîner des dommages ou de graves blessures aux personnes.
- Un équipement de sécurité et les outils appropriés doivent être utilisés. Ce produit devrait être installé uniquement par des professionnels.
- Assurez-vous que la surface de soutien supporte en sécurité le poids combiné de l'équipement et de tous les matériaux et composants associés.
- Utilisez les vis de montage fournies et NE SERREZ PAS TROP les vis de montage.
- Ce produit contient de petites pièces qui peuvent causer un étouffement si elles sont avalées. Éloignez ces pièces des enfants.
- Ce produit est prévu uniquement pour une utilisation à l'intérieur. L'utilisation de ce produit à l'extérieur peut entraîner une défaillance du produit ou des blessures aux personnes.

IMPORTANT: Avant l'installation, assurez-vous que vous avez reçu toutes les pièces selon la liste de vérification des composants. Si une pièce est manquante ou endommagée, téléphonez à votre distributeur local pour qu'il la remplace.

MAINTENANCE: A intervalles réguliers (au moins tous les trois mois) vérifiez que le support est d'utilisation sûre et fiable.

RU  Перед началом установки и сборки прочитайте руководство по установке. Если у Вас возникли какие-либо вопросы относительно инструкций или предупреждений, свяжитесь с Вашим местным распространителем для получения помощи.

Внимание: Использование продуктов, вес которых превышает указанный расчетный вес, может привести к нестабильности и возможным повреждениям.

- Стелы должны быть установлены, как это показано в монтажных инструкциях. Неправильная установка может привести к получению серьезных травм.
- Необходимо использовать предохранительное устройство и специальные инструменты. Продукт должен устанавливаться только профессионалами.
- Убедитесь, что несущая поверхность выдержит вес оборудования и всего установленного оборудования и комплектующих.
- Необходимо использовать заглушки в комплекте установочные шурупы и НЕ ПЕРЕТЯГИВАЙТЕ установочные шурупы.
- Данный продукт содержит маленькие детали, которые представляют опасность удушья при проглатывании. Такие детали необходимо хранить в недоступном для детей месте.
- Данный продукт предназначен только для эксплуатации в помещениях. Использование данного продукта на улице может привести к поломке продукта и получению травм.

ВАЖНО: Перед установкой убедитесь, что Вы получили все детали в соответствии со списком комплектующих. Если не хватает каких-либо деталей или они повреждены, свяжитесь с Вашим местным распространителем по вопросу замены.

ТЕХНИЧЕСКОЕ ОБСЛУЖИВАНИЕ: Необходимо регулярно проверять (как минимум, раз в три месяца), чтобы кронштейн был зафиксирован, и его использование было безопасным.

ES  Lea todo el manual de instrucciones antes de comenzar la instalación y ensamble de la unidad. Si tiene alguna inquietud con respecto a las instrucciones o advertencias, comuníquese con su distribuidor local.

PRECAUCIÓN: utilizar con productos de mayor peso al indicado en los límites de peso podría ocasionar inestabilidad y posibles heridas personales.

- Los soportes deben acoplarse tal como se indica en las instrucciones de ensamble. Una incorrecta instalación podría ocasionar daños y serias heridas personales.
- Utilice las herramientas y equipo de seguridad adecuados. Este producto solo debe ser instalado por profesionales.
- Asegúrese de que la superficie de fijación sostenga de manera segura el peso total del equipo y todos sus componentes y hardware.
- Utilice los tornillos de ensamble suministrados y NO aplique demasiada tensión a los tornillos.
- Este producto contiene piezas pequeñas que representan un riesgo de asfixia. Mantenga estas piezas fuera del alcance de los niños.
- Este producto está diseñado para uso en interiores solamente. Utilizar este producto en exteriores podría ocasionar fallas y heridas personales.

IMPORTANTE: Asegúrese de que haya recibido todas las piezas según la lista de verificación de componentes para la instalación. Si falta alguna de las partes, o está dañada, comuníquese con su distribuidor.

MANTENIMIENTO: Compruebe periódicamente que el soporte esté asegurado y listo para usar (al menos cada tres meses).

PT  Leia todo o manual de instruções antes de iniciar a instalação e montagem. Se você tiver alguma dúvida sobre quaisquer uma das instruções ou avisos, por favor, entre em contato com o seu distribuidor local para assistência.

ATENÇÃO: O uso com produtos mais pesados do que os pesos indicados pode resultar em instabilidade, causando possíveis danos.

- Os suportes devem ser anexados como especificado nas instruções de montagem. A instalação incorreta pode causar danos ou sérias lesões pessoais.
- Equipamentos de segurança e ferramentas adequadas devem ser utilizadas. Este produto só deve ser instalado por profissionais.
- Certifique-se que a superfície de suporte suportará com segurança o peso combinado do equipamento e todas as ferragens e componentes anexados.
- Use os parafusos de montagem fornecidos e NÃO APERTE EXCESSIVAMENTE os mesmos.
- Este produto contém pequenas peças que podem causar asfixia se ingeridas. Mantenha essas peças longe do alcance de crianças.
- Este produto destina-se somente para uso interno. Usá-lo em ambiente externo pode causar falhas no produto e lesões pessoais.

IMPORTANTE: Assegure-se que você recebeu todas as peças, de acordo com a lista de componentes, antes da instalação. Se alguma peça estiver faltando ou é defeituosa, contate o seu distribuidor local para substituição.

MANUTENÇÃO: Certifique-se que o suporte seja seguro e protegido para o uso em intervalos regulares (pelo menos a cada três meses).



PACKAGE CONTENTS

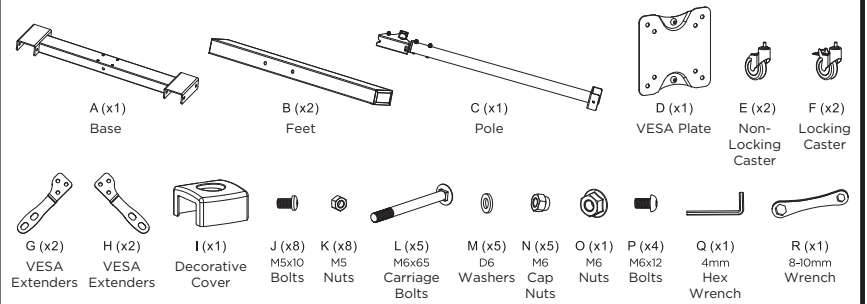

Mounting Hardware

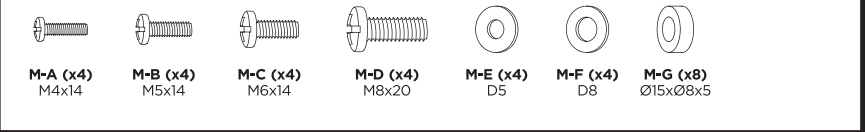

Check carefully to make sure there are no missing or defective parts. Some hardware provided may not be used. Use the correct mounting hardware suitable for your installation.

CHOKING HAZARD. Package includes small parts. Not for children under 3 years. Adult supervision is required.

Missing Parts? Call us at (855) 925-5668 and we will ship replacement parts free of charge.

DIMENSIONS & WEIGHT CAPACITY

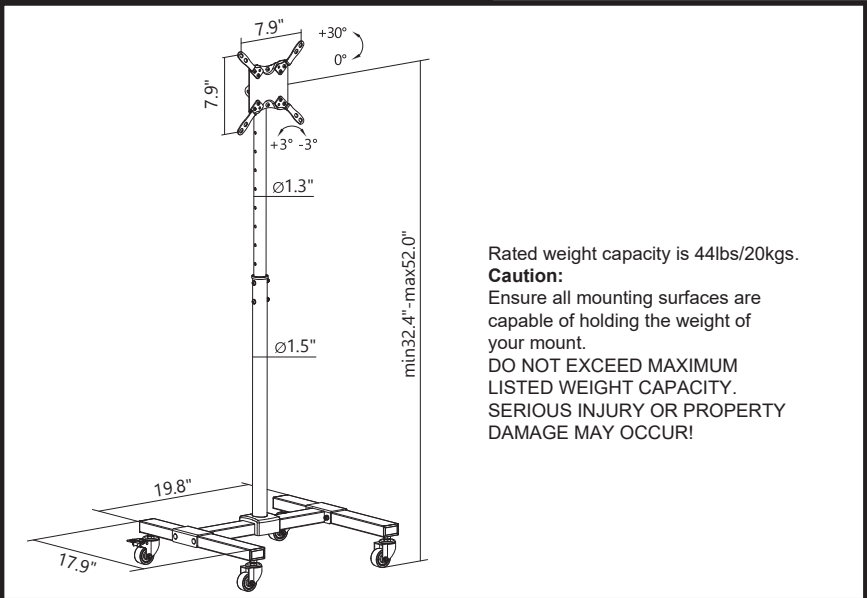

Step 1

Assemble the Base

- Place the Base (#A) over the Feet (#B) in the orientation shown here, then secure them together using the Carriage Bolts (#L) from the outside and secure them on the inner side using the Washers (#M) and Cap Nuts (#N).
- Attach the Casters (#E, F) in the orientation shown here, so that the Locking Casters (#F) are on the longer front end of the base.

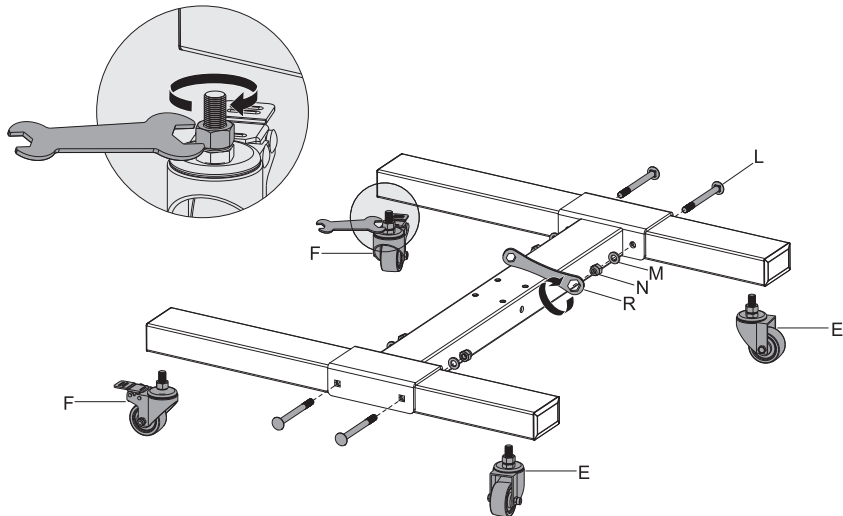
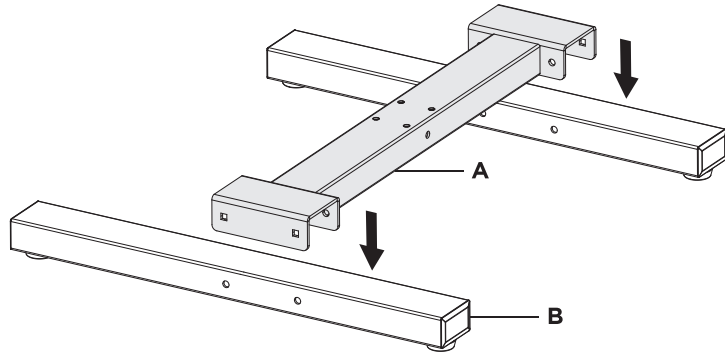

Step 2

Install the Decorative Cover

- Separate the inner and outer Pole (#C) by removing the set of 2 bolts shown here.

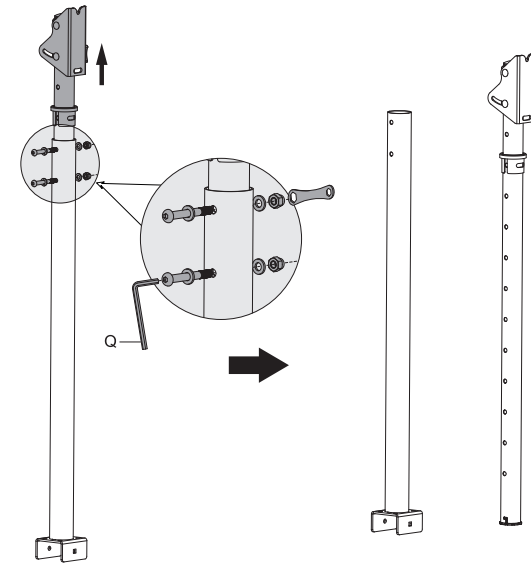

Step 3

Install the Decorative Cover

- Slide the Decorative Cover (#I) over the outer pole, then replace the inner pole and reinstall the bolts, washers, and nuts.

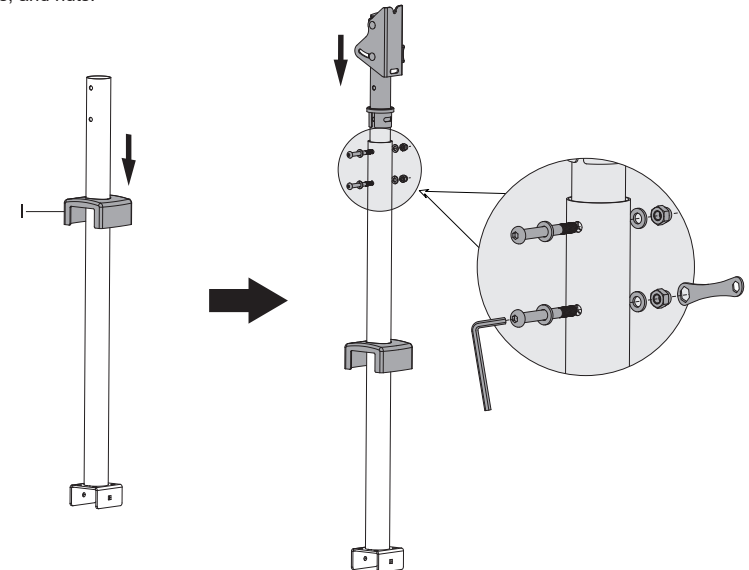

Step 4

Connect the Pole to the Base

- Place the Pole (#C) over the center of the base, so that the front of the pole is facing the same direction as the longer ends of the feet to ensure the weight of the TV is balanced by the longer side of the feet.

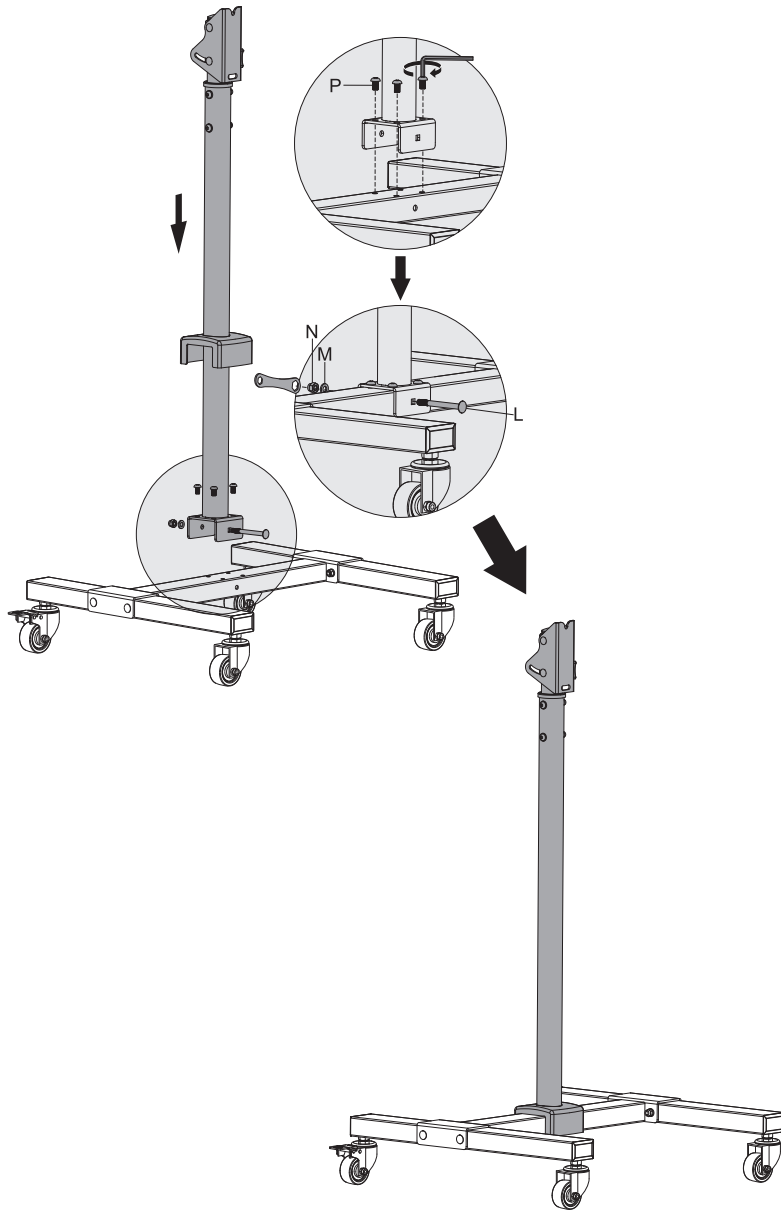

Step 5a

Attach the VESA Plate to the TV - VESA 75x75, 100x100.

- Select the appropriate size mounting bolt (Select one size #M-A, M-B) and washer (#M-E) for your display's mounting holes and verify the length of the VESA bolt is not too long. If you are unsure of the correct bolt size for your display refer to your display's user manual or contact the display's manufacturer for sizing information. If necessary, use the included spacers (#M-G) between the mount and the screen to adjust the length of the mounting bolt. Multiple spacers can be used in combination to achieve the desired bolt depth. Attach the VESA Plate using the selected bolts and washers then tighten until secure. Do not over tighten.

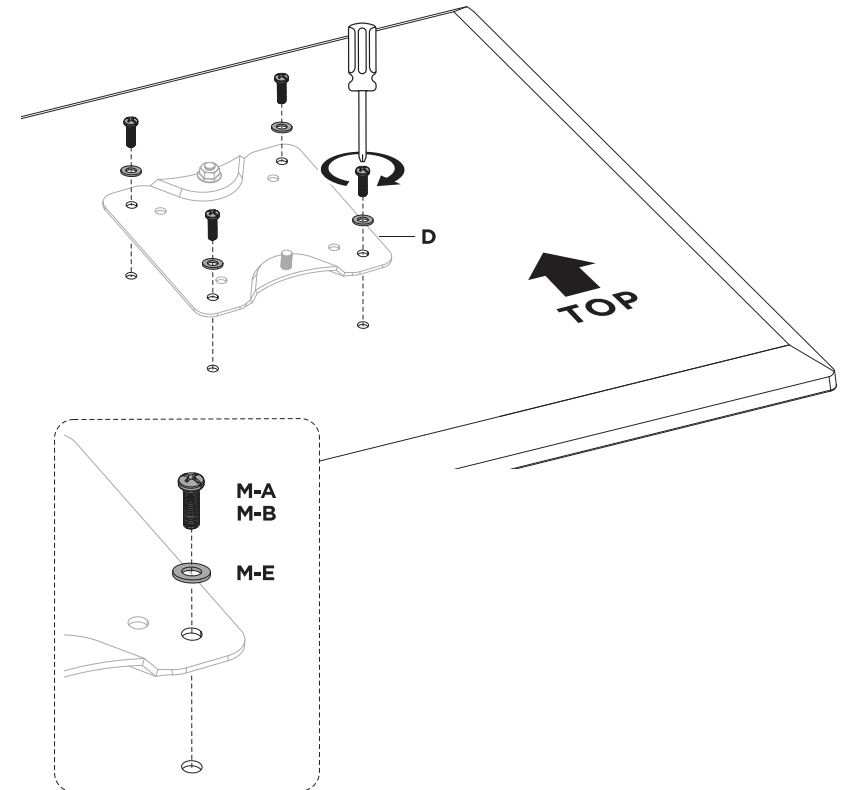

Step 5b-1

Extender Configuration for VESA 200x200

• For screens with a VESA pattern 200x200, attach the VESA Extenders (#G, #H) to the VESA Plate in the configuration shown using the Bolts (#J) and Nuts (#K).

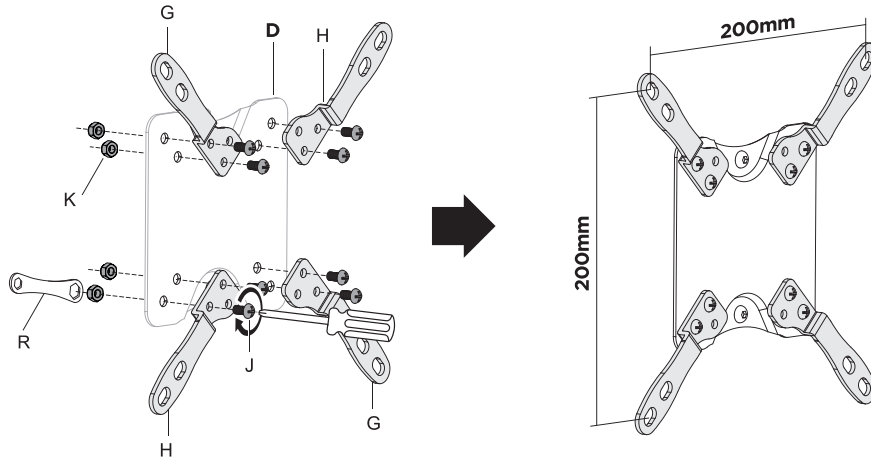

Extender Configuration for VESA 200x100

• For screens with a VESA pattern 200x100, attach the VESA Extenders (#H, #G) to the VESA Plate in the configuration shown using the Bolts (#J) and Nuts (#K).

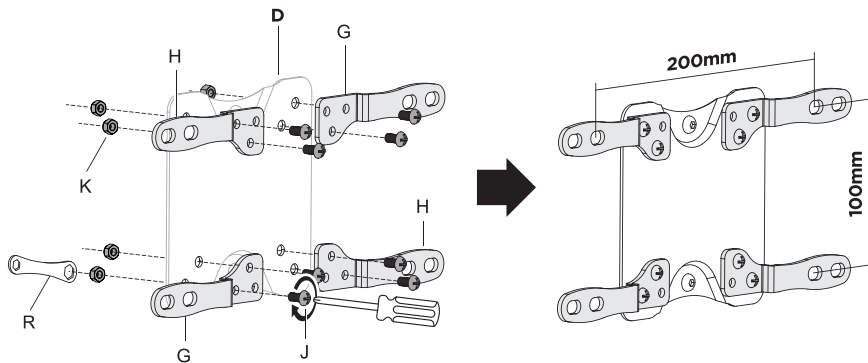

Step 5b-2

Attach the VESA Plate to the TV – With Extenders

• Select the appropriate size mounting bolt (Select one size #M-A, M-B) and washer (#M-E) for your display's mounting holes and verify the length of the VESA bolt is not too long. If you are unsure of the correct bolt size for your display refer to your display's user manual or contact the display's manufacturer for sizing information. If necessary, use the included spacers (#M-G) between the mount and the screen as shown to adjust the length of the mounting bolt. Multiple spacers can be used in combination to achieve the desired bolt depth. Attach the VESA Plate using the selected bolts and washers then tighten until secure. Do not over tighten.

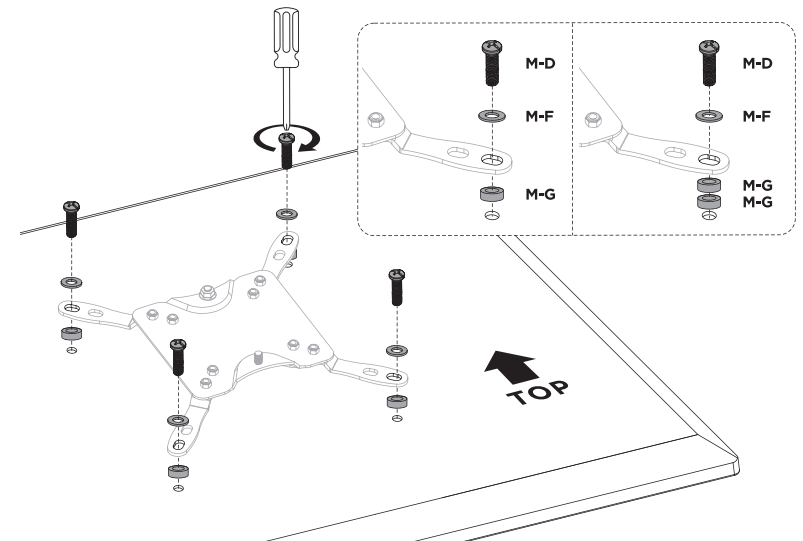
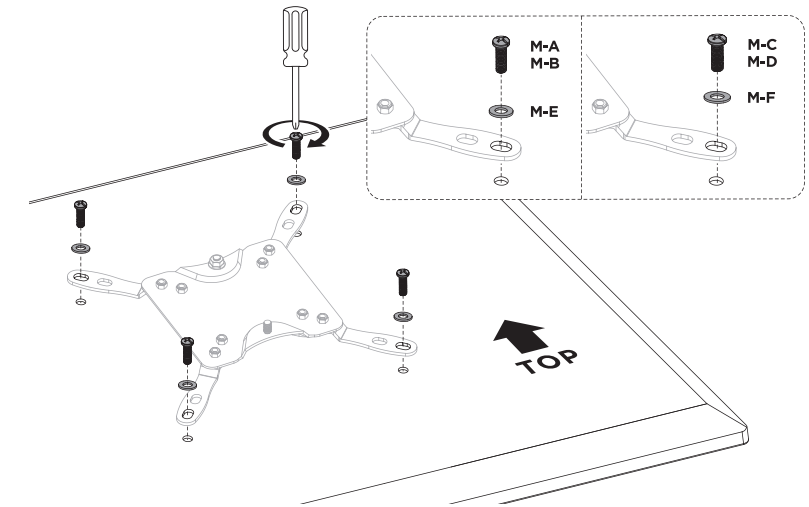
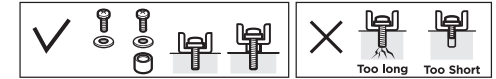

Step 6

Hang the TV on the Pole

- Hang the TV onto the top of the Pole, then attach the Nut (#O) to the lower threaded bolt on the VESA Plate. Level the TV if needed and tighten the two Nuts on the top and bottom of the VESA Plate to secure the TV in place.

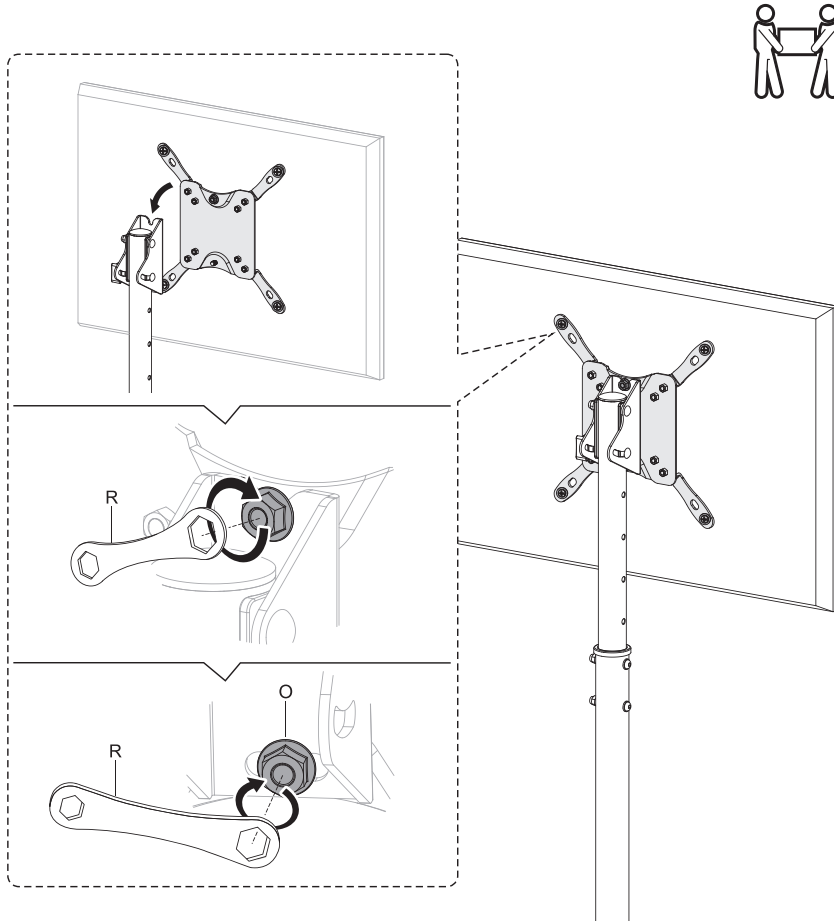

Step 7

Final Adjustments

- The screen can be leveled $\pm 3^\circ$ by adjusting the nuts installed in the previous step 6. The screen can be tilted back up to 30° by adjusting the bolts on the side of the pole, behind the VESA Plate.

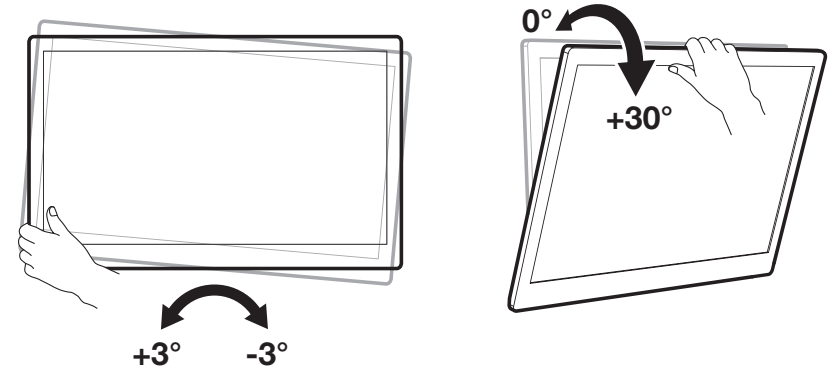

Visit us at www.mount-it.com for product registration and warranty information.

Our US based customer service team is standing by to answer any questions you have about your Mount-It! product.



support@mount-it.com

Available by phone **Monday - Friday from 5:00am to 5:00pm** PST.



(855) 925-5668

Chat live with an agent on our website!



www.mount-it.com