

Installation Instruction

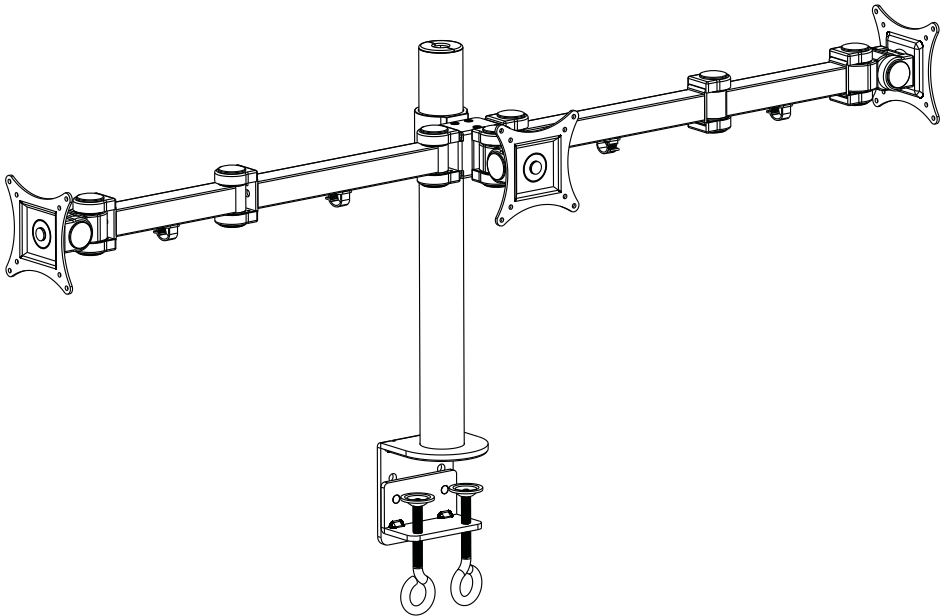

UNPACKING INSTRUCTIONS

- ! Carefully open the carton, remove contents and lay out on cardboard or other protective surface to avoid damage.
- ! Check package contents against the Supplied Parts List in the next page to assure that all components were received undamaged. Do not use damaged or defective parts.
- ! Carefully read all instructions before attempting installation.

IMPORTANT SAFETY INFORMATION

- ! Install and operate this device with care. Please read this instruction before installation, and carefully follow all instructions contained herein. Use proper safety equipment during installation.
- ! Please call a qualified installation contractor for help if you don't understand these directions or have any doubts about the safety of the installation.

Do not use this product for any purpose or in any configuration not explicitly specified in this instruction. We hereby disclaims any and all liability for injury or damage arising from incorrect assembly, incorrect mounting, or incorrect use of this product.

Supplied Parts List

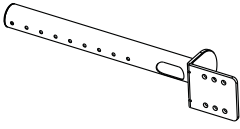

(1) 48mm Tube Support-a

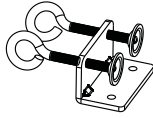

(1) Disconnected "C" Clamp-b

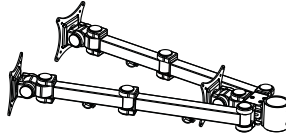

(1) VESA Plate with Arm Assembled-c



(1) Wrench-l

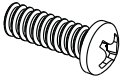

(12) M4x12 Bolt-d

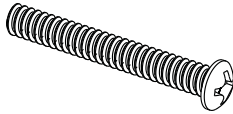

(12) M4x30 Bolt-e

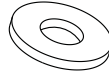

(24) M4 Washer-f

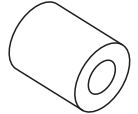

(12) M4 Space-g



(2) M8x10 Bolt-h

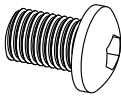

(2) M10x15 Bolt-i

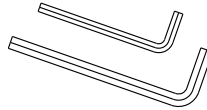

(1) Allen Key-j

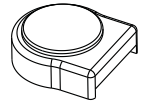

(2) Spare Plastic Cover-k

Tools Required

Phillips Screwdriver



WARNING

CAUTION!

This monitor desktop mount must be securely attached to the horizontal desk. If the mount is not properly installed it may fall, resulting in possible injury and/or damage.

Step 1

Install the "C" Clamp According to the Desktop Thickness

The depth of "C" clamp can be changed in three positions. Choose the proper depth according to the thickness of your desktop. Connect it by 2pcs M10x15 bolts(i), using the supplied Allen Key(j).

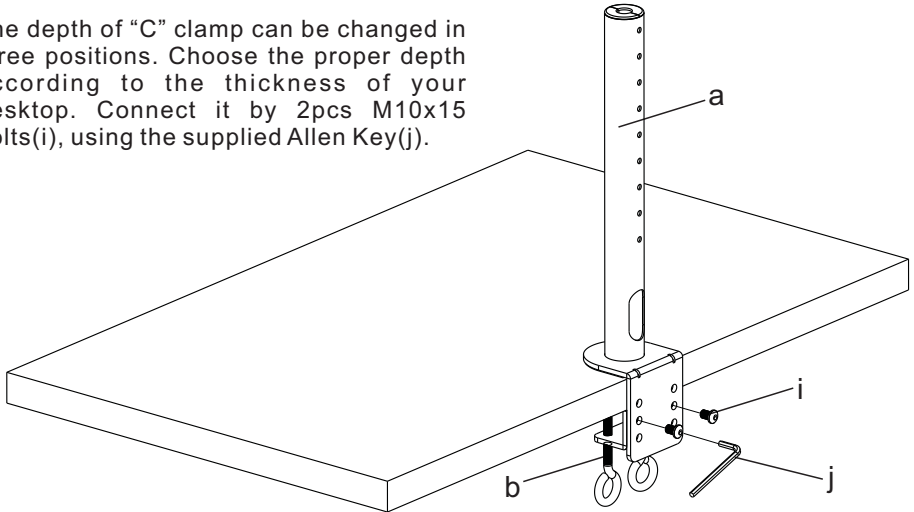

Step 2

Install Arm to the Tube Support

Install arm to the tube support, please make sure the wire clip in the downside. Fasten the bolt by screw driver.

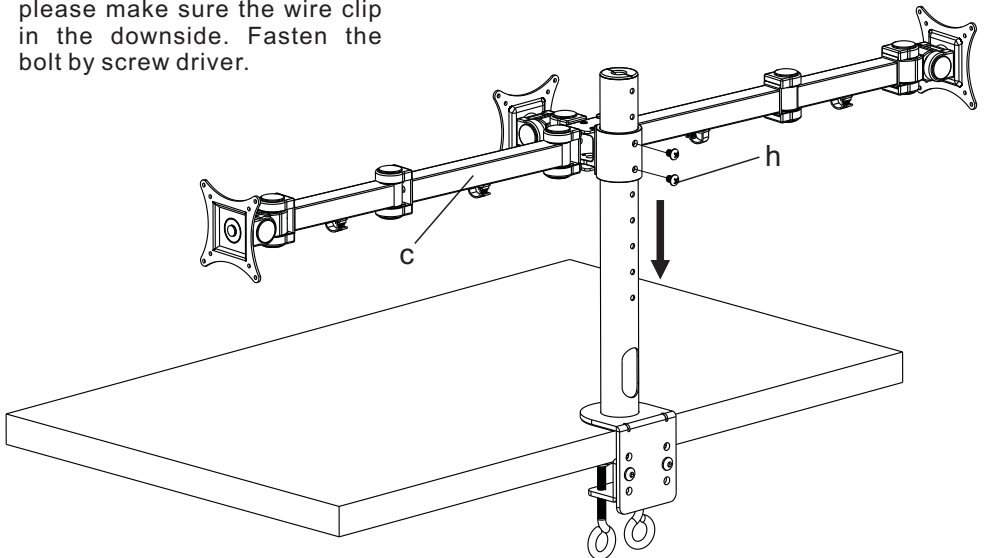

Step 3

Mount the Monitor to VESA Plate

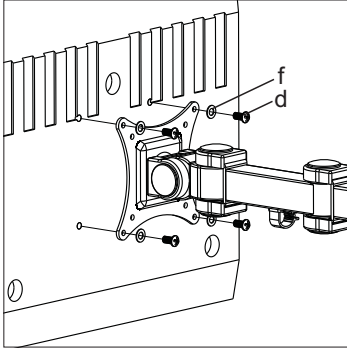

For Flat Back Monitor

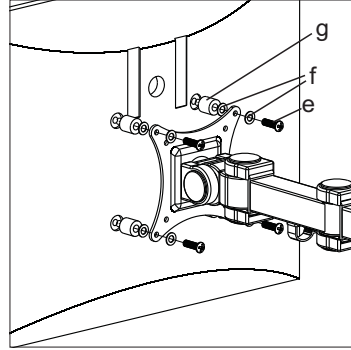

For Curved Back Monitor

Step 4

Manage the Wires and Adjust the Turning Tension

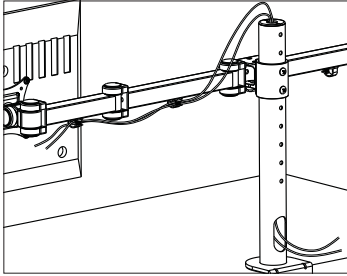

Manage the wires by the wire clips, some wires can be hidden inside the pipe.

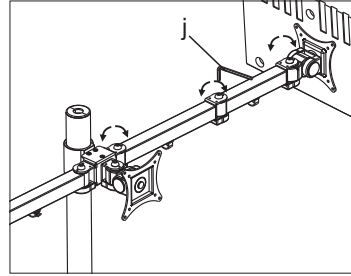

Remove the plastic cover, use the Allen Key(j) to adjust the turning tension.

Step 5

Fix the Tilt Angle and Adjust the Level of the Monitors

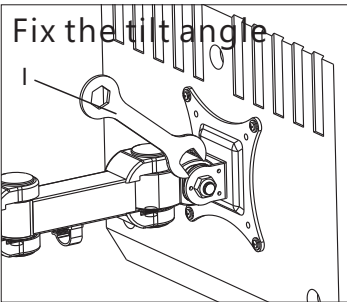

Fix the tilt angle

Remove the plastic cover, tighten the nut by the Wrench(l) to fix the tilt angle.

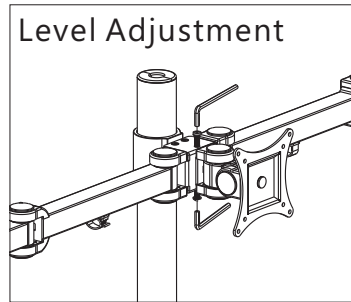

Level Adjustment

Loosen the bottom bolt and fasten the top bolt to lower the center monitor.