

# KEYGRIP

BY IMPACT

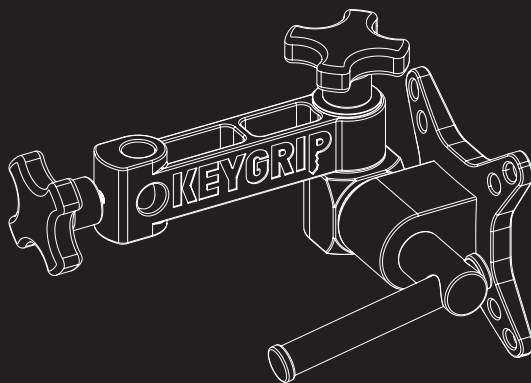

# HEAVY-DUTY VESA MONITOR MOUNT

WITH BABY RECEIVER

# Thank you for choosing Keygrip.

The Impact BVMM-HD will securely mount a large professional studio monitor that weighs up to 75 pounds to a light stand or any grip gear with a 5/8-inch baby pin. This sturdy monitor mount features 75 and 100 mm VESA configurations, and mounting hardware is included. For strength and rigidity, the mount is CNC milled from solid aluminum, and the metal knobs and a steel slide handle add to the durability and torquing power of this rugged accessory. Articulating joints allow for swivel and tilt adjustment and are secured with milled friction-control rosettes that prevent slipping.

# Precautions

- Please read and follow these instructions, and keep this manual in a safe place.
- Make sure everything is secure before proceeding.
- Light stands should have proper load capacity and footprint diameter to support the monitor.
- Use this mount only in the correct orientation: with the swivel knob pointing up or down. Do not use this mount in any other orientation.
- If the monitor has multiple VESA mounting options, mount the VESA plate in the center of the monitor.
- Light stands should be sandbagged for additional stability.
- Do not exceed the maximum load capacity.
- All images are for illustrative purposes only.

# Overview

1. Light stand socket (vertical mounting)
2. Wall plate socket (horizontal mounting)
3. Locking knob
4. Swivel knob
5. Tilt handle

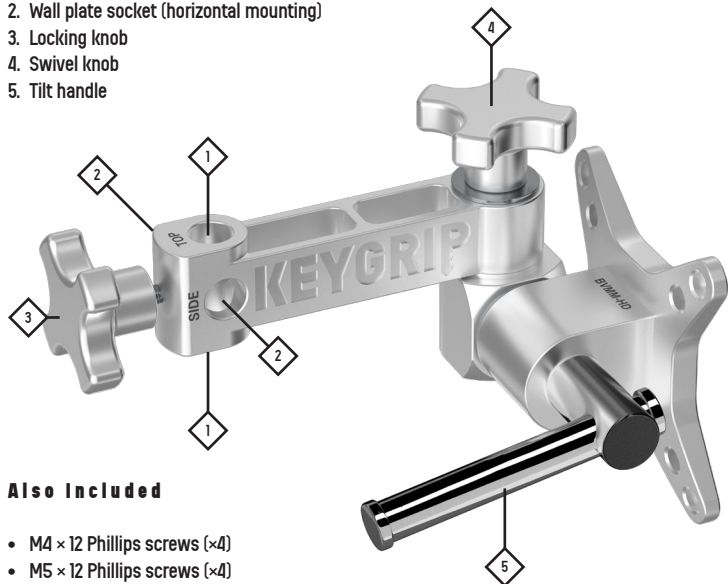

## Also Included

- M4 × 12 Phillips screws (×4)
- M5 × 12 Phillips screws (×4)
- M4 × 8 washers (×12)
- M5 × 9 washers (×12)

# Setting Up the Mount

## Attaching the Monitor

**Important!** If the monitor has multiple mounting options, mount the VESA plate in the center of the monitor.

Before you attach the VESA plate, hand-thread one of the M4 or M5 screws into the monitor's VESA holes to determine which one fits the monitor.

1. Place the monitor down on a stable and padded flat surface.
2. Place the VESA plate on the back of the monitor.
3. Place a washer on each of the screws, and attach the BVMM-HD with a Phillips screwdriver.

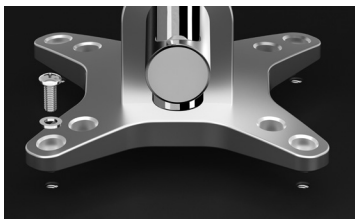

**Important!** A snug fit is essential for a secure monitor mount. If the monitor's VESA holes are shallow and won't allow the screws to form a tight connection, use the included extra washers as spacers.

# Before You Start

Whether mounting the BMVV-HD vertically to a light stand, or horizontally to a wall plate, use only the correct orientation. **The swivel knob must be pointing up or down. Any other orientation risks an insecure mount and damage to your monitor.**

Correct orientation is with the swivel knob (green) pointing up or down.

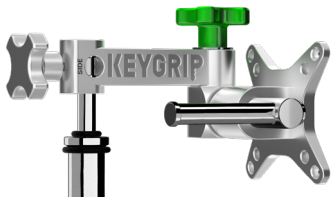

Swivel knob pointing up

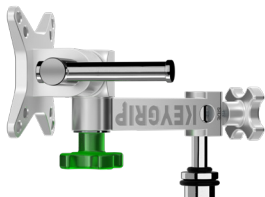

Swivel knob pointing down

Incorrect orientation is with the swivel knob (red) pointing to either side.

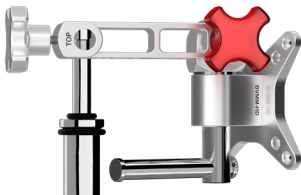

Swivel knob pointing to the side

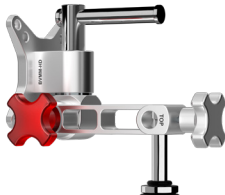

Swivel knob pointing to the side

# Mounting to a C-stand or Baby Pin

## Vertical Mounting to a Light Stand

Performing this operation with two people is recommended.

1. Loosen the locking knob and fit the monitor mount onto the baby pin until the pin is fully inserted into the receiver.
2. Tighten the locking knob until secure.

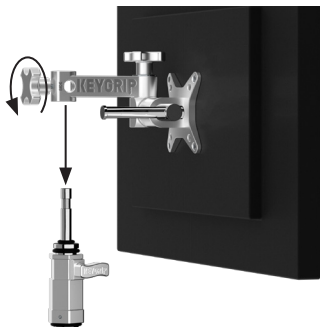

## Horizontal Mounting to a Wall Plate

Follow the same attachment procedure, and make sure the swivel knob is pointing up or down to assure the correct orientation.

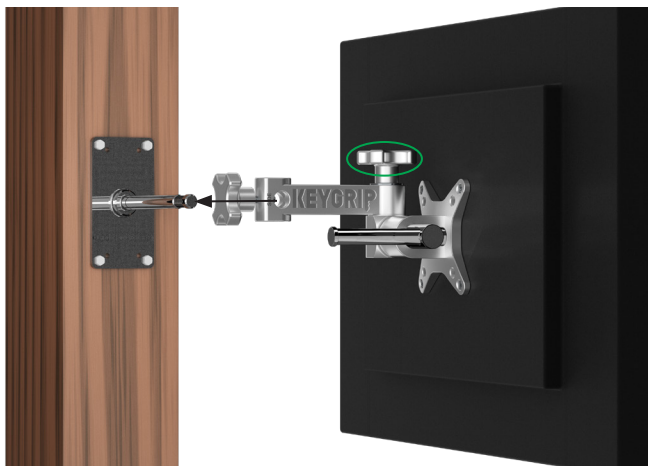

# Adjusting the Monitor

Use the slide handle to adjust the monitor's tilt angle.

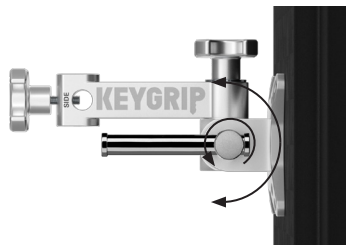

Use the knob to adjust swivel.

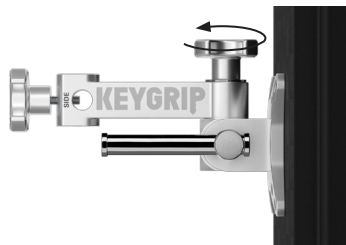

**Note:** To help store or transport the mount, unscrew the slide handle's end cap and remove the slide handle from the mount.

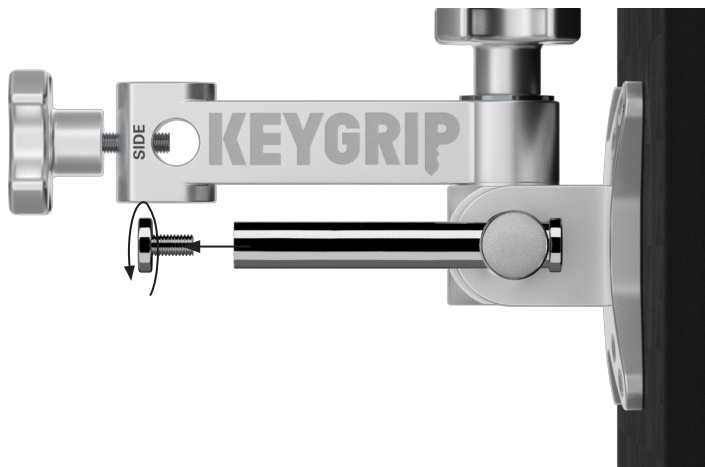

# Specifications

## BVMM-HD

<b>Maximum Load</b>	75 lb. (34 kg)
<b>Mount Type</b>	5/8 in. (16 mm) baby receiver
<b>VESA Compatibility</b>	75 × 75 mm 100 × 100 mm
<b>Material</b>	Aluminum, Steel
<b>Dimensions (L × H × D)</b>	9 × 6 × 5.75 in. (22.9 × 15.2 × 14.6 cm)
<b>Weight</b>	3.74 lb. (1.7 kg)

# One-Year Limited Warranty

This KEYGRIP by Impact product is warranted to the original purchaser to be free from defects in materials and workmanship under normal consumer use for a period of one (1) year from the original purchase date or thirty (30) days after replacement, whichever occurs later. The warranty provider's responsibility with respect to this limited warranty shall be limited solely to repair or replacement, at the provider's discretion, of any product that fails during normal use of this product in its intended manner and in its intended environment. Inoperability of the product or part(s) shall be determined by the warranty provider. If the product has been discontinued, the warranty provider reserves the right to replace it with a model of equivalent quality and function.

This warranty does not cover damage or defect caused by misuse, neglect, accident, alteration, abuse, improper installation or maintenance. EXCEPT AS PROVIDED HEREIN, THE WARRANTY PROVIDER MAKES NEITHER ANY EXPRESS WARRANTIES NOR ANY IMPLIED WARRANTIES, INCLUDING BUT NOT LIMITED TO ANY IMPLIED WARRANTY OF MERCHANTABILITY OR FITNESS FOR A PARTICULAR PURPOSE. This warranty provides you with specific legal rights, and you may also have additional rights that vary from state to state.

To obtain warranty coverage, contact the Impact Customer Service Department to obtain a return merchandise authorization ("RMA") number, and return the defective product to Impact along with the RMA number and proof of purchase. Shipment of the defective product is at the purchaser's own risk and expense.

For more information or to arrange service, visit [www.impactstudiolighting.com](http://www.impactstudiolighting.com) or call Customer Service at 212-594-2353.

Keygrip and Impact are registered trademarks of the Gradus Group.  
© 2024 Gradus Group LLC. All Rights Reserved.

