

MODEL

VFL201D

Digital I/F LCD Color Viewfinder

Operation Manual

English

Ikegami

Safety Precautions

Please follow the safety instructions below:

Before you use this unit, be sure to familiarize yourself with this “Safety Precautions” and the “Operation Manual” to use the unit in the proper manner.



After reading these documents, be sure to keep them in a safe place for your reference whenever the information is required.

Concerning Pictographic Symbols

The pictographic symbols contained in this “Safety Precautions” and placed on the units are provided by using various pictographs to ensure that you use this unit in the safe manner and to protect yourself or other persons from any hazards and to prevent any damages occurring from this unit.



The pictographic indications and their meanings are given below. Please thoroughly understand these indications and their meanings before using this unit.

Please understand that there may be some pictographic symbols that may not apply to the unit you purchased.

	Warning This symbol indicates a content that any erroneous handling of this unit committed by ignoring this symbol may cause an accident resulting in death or serious injury.
	Caution This symbol indicates a content that any erroneous handling of this unit committed by ignoring this symbol may cause an accident resulting in serious injury or in property loss or damage.





(Note) The Δ symbol indicates a content to call for the user’s attention.

Example of Symbols





	The ○ symbol indicates that the action is prohibited. In the diagram or in its vicinity, the concrete contents of prohibition is illustrated. (In the diagrams at left, it is a caution against disassembly of the unit.)
	The ● symbol indicated that the action must be carried out in a coercive manner. In the diagram, the concrete content of caution is illustrated (In the diagrams at left, the power plug must be pulled out.)

Warning









When you use the product:

	Do not place any container containing water or any liquid or small metallic pieces on the unit! Spilt liquid entering inside the unit may cause a fire or an electric shock accident.
	Do not use the unit by applying any voltage other than the specified voltage! Application of an unspecified voltage to the unit may cause a fire or an electric shock accident.
	Do not allow any metallic or combustible material to enter or be dropped into the unit from an opening! This may cause a fire or an electric shock accident.
	Do not make any alterations to this unit! This may cause a fire or an electric shock accident.

When you install the product:





	Do not install this unit on an unstable position! By doing so, the unit may be dropped or fall down, causing a personal injury.
	Do not use the unit by applying any voltage other than the specified voltage! Application of an unspecified voltage to the unit may cause a fire or an electric shock accident.
	Be sure to employ a specialized engineering constructor to install the unit in place! This unit must be securely installed in place by using the specified method. Otherwise, it may be dropped or fall down, causing a fire, an electric shock, or a personal injury. If the unit is to be installed on the wall or on the ceiling, be sure to employ a specialized engineering constructor for the work.
	Do not make any alterations to this unit! This may cause a fire or an electric shock accident.

When a trouble has occurred:

 	If an abnormal condition should occur, indicated by smoke, strange odor, or noise, be sure to turn off the power switch and unplug the power plug from the outlet! If you keep using the unit as is, a fire or an electric shock accident may occur. Make sure that the smoke has gone out and contact our sales agent or the sales person in charge.
 	If water or any foreign object has entered inside the unit, turn off the power switch and unplug the power plug from the outlet! If you keep using the unit as is, a fire or an electric shock accident may occur. Contact our sales agent or the sales person in charge.
 	If the unit is dropped down or its case is broken, turn off the power switch and unplug the power plug from the outlet! If you keep using the unit as is, a fire or an electric shock accident may occur. Contact our sales agent or the sales person in charge.
 	If this unit should go out of order, turn off the power switch and unplug the power plug from the outlet! If you keep using the unit as is, a fire or an electric shock accident may occur. Contact our sales agent or the sales person in charge.
	Do not use any damaged (with the core wire exposed or broken) power cord! If you keep using the unit as is, a fire or an electric shock accident may occur. Contact our sales agent or the sales person in charge.

Caution

When you use the product:

	Do not place any heavy object on this unit! By doing so, the unit may lose the balance and fall down or be dropped down, causing personal injury.
	Do not get on or sit on this unit or the carrying case! The unit may be broken or fall down, resulting in personal injury.
	Before moving the unit, be sure to turn off the power switch and unplug the power plug from the outlet and disconnect the connecting cables between devices! If you fail to do so, the power cord may be damaged, causing a fire or an electric shock accident.
	If the unit is not to be used for a long time, be sure to unplug the power plug from the outlet for safety. Failure to do so may cause a fire.

When you install the product:

	Do not block the ventilation holes of this unit! Blocking the ventilation hole may cause heat to build up inside the unit, causing a fire. Do not use the unit in the following manner: <ul style="list-style-type: none"> • Putting the unit upside down; toppling it over sideways; or inverting it. • Pushing unit onto a narrow place with poor ventilation. • Placing the unit on a soft material such as carpet. • Covering the unit with a piece of table cloth, etc.
---	---

To Use the Product Proficiently

When you use the product:

<ul style="list-style-type: none"> • When using the unit at a watery location such as near a bath or poolside, do not allow water to enter this unit or the cables. The water that has entered the unit or the cables may cause an electric accident. Please be especially careful when you use it when it is raining or snowing; near the beach; or in the kitchen.
<ul style="list-style-type: none"> • If thunder is heard, be sure to use the unit by considering the operating environment and the situation. If required, interrupt the use of the unit, and keep off the unit, or else you may receive an electric shock.
<ul style="list-style-type: none"> • Do not connect any device to an AC outlet with a power rating (W) exceeding the rating allowed for the outlet. Be sure to check the power rating value indicated near the AC outlet or the Instruction Manual, or the Operation Manual.
<ul style="list-style-type: none"> • Do not use the power cord or connecting cables by forcefully bending (or twisting or pulling) them. By doing so, the insulation of the cord or cables may be damaged, causing an electric shock accident to occur.

When you install the product:

<ul style="list-style-type: none"> • Install the unit by keeping it away from a location exposed to excessive humidity or dust, oily smoke, or steam. Installation of the unit on such a location may cause an electric shock. Do not place the unit near a cooking table or a humidifier.
<ul style="list-style-type: none"> • Make sure that the unit is securely protected from falling by a sudden earthquake or a shock. Be sure to carry out a falling prevention measure for safety to ensure that no personal injury will occur by falling of this unit.

Concerning Maintenance of the Product:

<ul style="list-style-type: none"> • For safety, be sure to turn off the power switch and unplug the power plug from the outlet before carrying out the maintenance of this unit. Failure to do so may cause an electric shock.
<ul style="list-style-type: none"> • To ensure that the unit will maintain its performance in a stable manner for a long time, it is recommended that a "Periodic Inspection" should be carried out. Please consult with the sales person in charge for Periodic Inspections.
<ul style="list-style-type: none"> • This unit contains some high voltage sections inside. Any inspection, maintenance or repair work of this unit must be carried out by a knowledgeable expert of this type of product, otherwise an electric shock accident may occur.

Precautions for Use

Read this document carefully and take precautions regarding the following issues to ensure the safe use of this Viewfinder.

1. Use of a power supply other than the specified supply (DC) is strictly forbidden.

2. Do not apply any shock on the view finder.

Take necessary precautions against shock, as glass materials are used inside OLED / LCD.

3. Don't apply strong external force against the screen of the viewfinder.

Don not press the screen strongly. Be careful not to apply strong external force to the screen of the viewfinder.

The screen may be damaged, causing a trouble.

4. Avoid using or storing the unit at following locations:

Locations with temperatures outside the specified range

In the open air environment, necessary precautions must be taken against radiation as heat may build up inside the unit by direct sunlight, even if the surrounding temperature may be within the specified range. (Be sure to protect the unit from direct sunlight.)

Make sure that the exhaust and the intake ports on the rear of the Viewfinder is never blocked. Check the exhaust port in particular to confirm that it is not blocked by the black-out curtain and the like.

Rainy, Snowy, and Excessively Humid Locations

May cause an electric leakage or malfunction of the unit.

5. Be careful of operation at low temperature

Keep in mind that the function of the backlight will be lower and the life will become short at low temperature. It is recommendable to use the unit at normal temperature.

6. Avoid direct sunlight to the screen of the viewfinder

Keep in mind that there is a possibility of spoiling the display performance when the screen of the viewfinder is exposed to the direct sunlight for a long period of time.

Avoid directly touching the surface of the OLED / LCD panel as much as possible. For cleaning the surface, use a piece of dry and soft cloth to wipe off the dirt without harshly rubbing the surface. Do not use any solvent such as thinner or benzene.

7. Do not display the same pattern for a long time.

Precautions should be taken as displaying the same pattern for a long time may cause burn-in on the screen.

- Turn off the power when the unit is not used.
- Change the displayed pattern regularly.
- Turn off the marker, WFM or VSC when not in use.

8. Precautions against dew condensation

If the unit is used in an environment exposed to sudden temperature changes, dew condensation may occur on the panel surface or inside the unit. Precautions must be taken as operating the unit while condensation is remaining may cause deterioration of the display quality or malfunction of the unit. If dew condensation should occur, do not turn on the power before the dew condensation is eliminated.

9. Do not touch crystalline liquid leaked from the screen of the viewfinder.

When the screen of the viewfinder is accidentally broken and the liquid (crystalline liquid) leaks, do not touch it with your mouth, do not inhale or do not get it to your skin.

If the crystalline liquid gets in your eye or mouth, rinse it immediately with water. If your skin or clothes are stained with it, wipe off with alcohol etc. immediately and wash in cold water with soap.

If left stained, your skin or clothes may be damaged.

If it gets in your eye or mouth, rinse it immediately with water and receive medical treatment from a doctor.

10. Avoid use or storage of the unit in a corrosive gas environment.

Use or storage of this product at a location or the vicinity here corrosive gas including sulfur dioxide, hydrogen sulfide gas, or ammonia gas is generated will not only significantly reduce the service life of the product but also may cause malfunction or an electric leakage. Also, avoid using the unit in an environment exposed to the strong salt winds.

11. When storing the viewfinder for a long period of time, do so in a cool, dark place at constant temperature and humidity.

12. Do not disassembly and remodel.

Do not disassemble and remodel the viewfinder, otherwise causing a trouble or damage.

13. Do not use this product for a space apparatus, a nuclear energy controlling device, or a medical instrument involved with human life.

Concerning the Quality of the OLED / LCD Panel

An extremely high precision technology is used to produce the OLED / LCD panel built in this product, providing 99.99% or higher effective pixels. Please understand, however, that there may be missing pixels or always illuminating pixels at a rate of 0.01% or lower.

Warranty

In case the product should malfunction in the course of normal operations within one year from the date of delivery, the product will be repaired free of charge. However, any repair for the following cases has to be paid even within the warranty period:

1. Any malfunction or damage that has occurred due to one of the following causes:
 - An improper use
 - A repair or an alteration carried out by the customer
 - Transportation, movement, or falling that has occurred after purchase of the product
 - An external factor including an extraordinary natural phenomenon or application of abnormal voltages
2. Aged deterioration of OLED /LCD panel
(Including changes in brightness; increases of light spots or unlit defects, etc.)
3. Damage, discoloration, or deterioration of the housing including the front surface of the panel

If it seems that the product is malfunctioning even after performing daily adjustments, indicated by a phenomenon such as no image available, please contact our sales agent or TECHNO IKEGAMI Co., Ltd.

Preface

● Accessories

The following accessories are available for the product. Check each item:

- **Operation manual (1)**
- **Mounting bracket (1)**

● Options

The following Options are available for the product. The “Offset hardware”, by which you can adjust the position of mic holder, is supplied for each mic holder.

Mic holder

Type No. :XM-164
(small antivibration ø21)

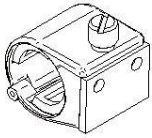

Mic holder

Type No. :XM-174A
(large antivibration ø19~21)

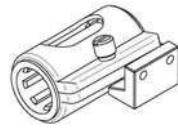

Mic holder

Type No. :XM-254
(large ø19~26.5)

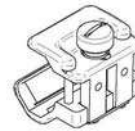

● How to Read the Operation Manual

This page explains general notes on reading the VFL201D Operation Manual, and the symbols and notations used in the manual.

Notes on the Manual

- This manual is written for readers with a basic knowledge of handling broadcast cameras.
- The contents of this manual are subject to change without notice in the future.

Symbols

The meanings of the symbols used in this manual are as follows:

CAUTION:	Things you have to be careful during operation. Be sure to read.
Note:	Supplementary information or guidance.
Term:	Explains the meaning of a term you need to know.

Notations

This following notations are used in this manual

This product, viewfinder, VF	Indicates VFL201D
------------------------------	-------------------

Illustrations and Displays

The illustrations and displays in the text are provided for explanation and may be slightly different from the actual equipment or image.

MODEL VFL201D

Digital I/F LCD Color Viewfinder

Table of Contents

Safety Precautions	i	4-3. Menu List (VF MENU).....	E-17
Precautions for Use	ii	4-4. How to operate and functional description of the menu (VF MENU).....	E-18
Preface	iv	(1) VF MENU (1/3) SETTING.....	E-20
1. Outline	E-1	(2) VF MENU (2/3) USER MARKER.....	E-21
1-1. Outline	E-1	(3) VF MENU (3/3) INFO / UPDATE.....	E-24
1-2. Features and Functions	E-1	5. Specifications	E-25
2. Names and Functions	E-2	5-1. General specifications	E-25
2-1. Front side.....	E-2	5-2. Rated performance	E-25
2-2. Back side	E-3	5-3. LCD panel specifications.....	E-25
2-3. Mounting/Removing the VFL201D to/from the Mount Attachment for UNICAM XE series cameras	E-3	6. Functions	E-26
2-4. Installation of microphone holder	E-4	6-1. Front operation	E-26
2-5. Detaching and installation of the eyepiece	E-4	6-2. Marker function.....	E-26
3. Two-way communication between VF and camera	E-5	6-3. Shadow function.....	E-26
3-1. Summary of two-way communication	E-5	6-4. User marker function	E-26
3-2. Functions which are possible by this two-way communication.....	E-5	6-5. Picture MAG. function.....	E-26
3-3. The initial start up process for the two-way communication.....	E-5	6-6. Peaking function.....	E-26
4. Menu Operation	E-7	7. Applicable Standards	E-27
4-1. Menu List (CAMERA MENU).....	E-7	7-1. Radio noise	E-27
4-2. Functional description of the CAMERA MENU	E-8	7-2. Environmental standards	E-27
(1) TOP MENU.....	E-8	8. Exterior Drawing	E-28
(2) VIDEO SETTING and TALLY MENU	E-9		
(3) PEAKING MENU.....	E-11		
(4) MARKER MENU	E-13		
(5) USER MARKER MENU.....	E-15		
(6) INFO / UPDATE MENU	E-16		

1. Outline

1-1. Outline

The VFL201D, which has been developed for our new 4K UNICAM XE camera series, is a 2-inch LCD viewfinder. This viewfinder applies the new Focus Assist function that supports accurate focusing for both 4K and HD modes. It has a high resolution QHD LCD with 960 (H) X 540 (V) pixels. It is possible for users to confirm the video quality with a high resolution and full color VF picture. We are able to realize the features, required in a viewfinder for broadcast use with the same ease of use as that of our conventional models, including our current UNICAM HD camera series, VF

1-2. Features and Functions

LCD with heater

A transparent heater is installed right under the liquid crystal layer. The ambient temperature is detected and heat is applied when needed to produce an image without deterioration due to the slow response speed typically observed, at low temperatures.

Full-color display of 16.7 million colors

16.7 million colors (8bit color) are achieved by a full-color display, and a high definition image is achieved.

Multiple peaking features

This viewfinder displays several peaking features, including “ZOOMUP PEAKING” which is synchronized with the lens zoom operation and “COLOR PEAKING” which can add color on the peaking signal, which supports good adjustment of focus.

Abundant markers with shadow

In addition to area markers, center marker, shadow feature and cross hatch marker, there are up to 6 user markers for each marker scene file, which users can setup freely. Also, 5 marker scene files are available.

Image magnification display feature

This viewfinder can display a magnified image to support accurate focusing.

2. Names and Functions

2-1. Front side

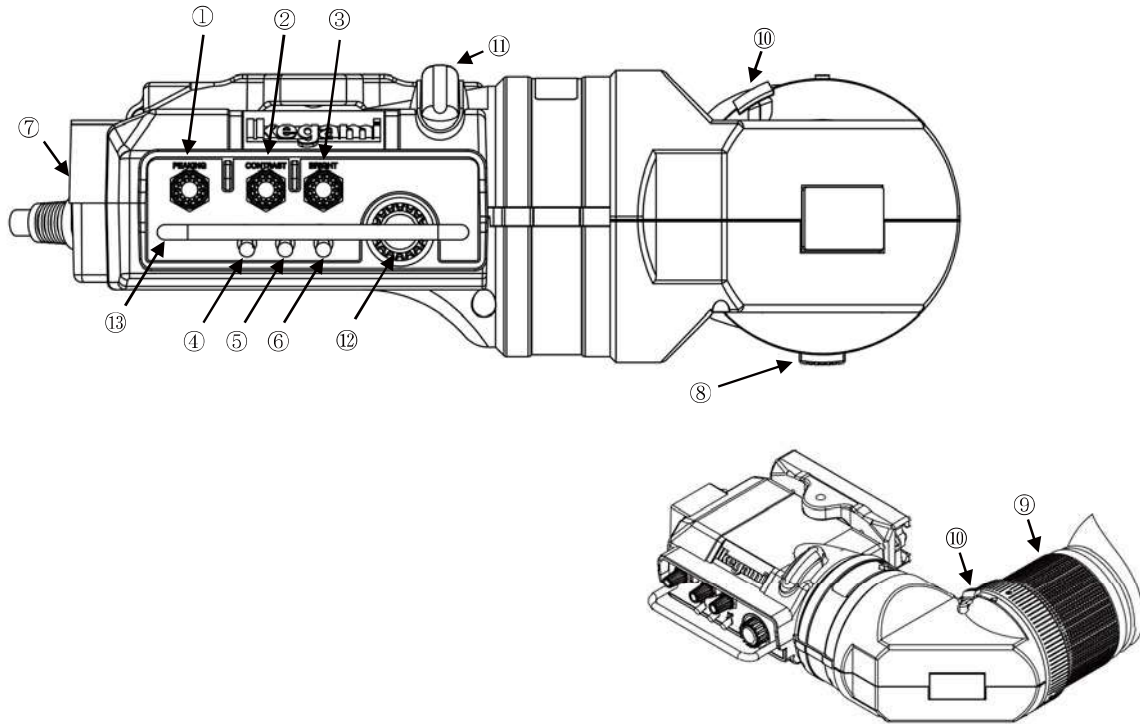

No.	NAME	FUNCTION
①	PEAKING VR	The amount of edge peaking for the image is adjusted.
②	CONT VR	The contrast of the image is adjusted.
③	BRIGHT VR	The brightness of the image is adjusted.
④	ASSIGNABLE F1	This can change the setting of a feature, which is assigned in the MENU. The default feature is "MONO".
⑤	ASSIGNABLE F2	This can change the setting of a feature, which is assigned in the MENU. The default feature is "USRMRK"
⑥	ASSIGNABLE F3	This can change the setting of a feature, which is assigned in the MENU. The default feature is "TALLY"
⑦	Mike holder fixation hole	It is a screw hole to install the mike holder.
⑧	Diopter movement lever	It is a lever for the diopter movement.
⑨	Eyepiece positioning ring	When back and forth adjustment for the position of the eye cup is needed, this ring is turned.
⑩	Eyepiece detaching lever	To detached the eyepiece, this lever is pushed.
⑪	Front Tally lamp	This is turned on by the control signal from the camera. Turning on can be prohibited by MENU.
⑫	Menu switch	This is used for setting the items in the MENU.
⑬	Protection bar	Some front switches and volumes are protected from external impact.

2-2. Back side

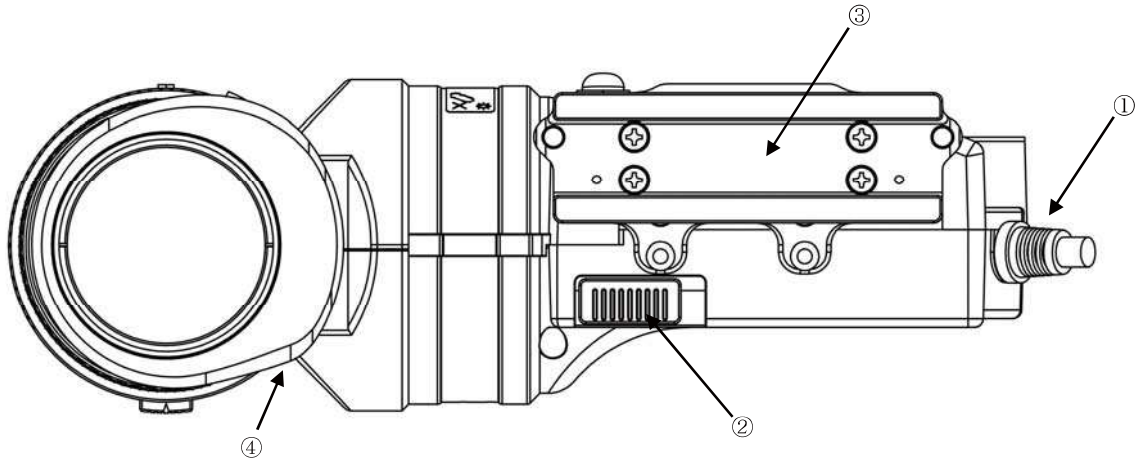

No.	NAME	FUNCTION
①	VF cable	The VF cable for the UNICAM XE series.
②	Rear tally with a cover	This will be turned on by the control signal from the camera. The cover can cut off the light of this tally, if needed.
③	Attachment to camera	This is the mounting hardware in order to install the VFL201D on the camera.
④	Eyepiece	This is an eyepiece to observe the VF image. Also, it has the dioptic lens feature.

2-3. Mounting/Removing the VFL201D to/from the Mount Attachment for UNICAM XE series cameras

■Mounting VFL201D to the Mount Attachment

This section explains the method of installing the VFL201D to a UNICAM XE series, camera.

CAUTION:

At first, please confirm whether the mounting hardware for the VF is installed in the camera.
If there is no mounting hardware in the camera, you can't install this VF.

- 1 The slide guide of the VF is aligned with the □ shaped edge of the mounting hardware for VF in the camera.
And the VF is mounted on the camera by sliding it while pushing the pin for blocking the VF from falling off.

CAUTION:

Please put the camera on a stable place and install the VF to the camera.

- 2 Please turn the VF fixing knob on the mounting hardware in the camera clockwise and fix the VF firmly.

MEMO:

Please position the VF in the horizontal direction after loosening the VF fixing knob.

- 3 The VF connector is connected with the VF connector of the camera.

CAUTION:

Please pay attention to the direction of the connector.

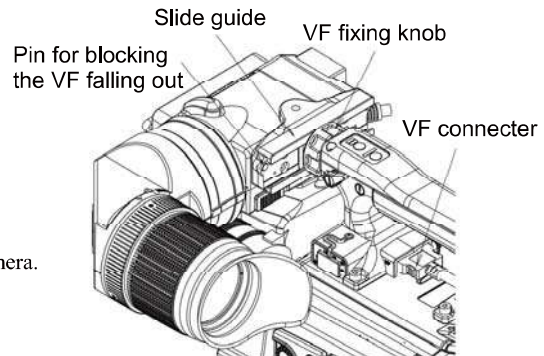

■Removing the VFL201D from the Mount Attachment

This section explains how to remove the VFL201D from the Mount Attachment.

- 1 Please remove the VF by the reverse procedure comparing with the mounting procedure.

CAUTION:

Please put the camera on a stable place and remove the VF from the camera.

2-4. Installation of microphone (mic) holder

■Mic holder installation

This section explains the method of mounting the mic holder to the VFL201D

First the off-set metal plate is fixed at the installation location using two M4 screws.

Next the mic-holder is installed at the off-set metal plate using a pair of M4 screws.

CAUTION:

Please pay attention not to lose the above special screw after removing the mic-holder.

2-5. Detaching and installation of the eyepiece

■The eyepiece can be detached

- 1 The detaching lever in the ring of the VF eyepiece is pushed, then the eyepiece is turned counter-clockwise, and it will be detached.

CAUTION:

Please take care that dust doesn't enter the inside of the VF after detaching the eyepiece.

■Eyepiece installation

- 1 Please align the arrow head displayed on the ring of the VF eyepiece with the arrow head displayed on the VF side and turn it clockwise while pressing the parts together, until you hear it click.

3. Two-way communication between VF and camera

3-1. Summary of two-way communication

For improved operation two-way communication with our camera (UNICAM XE series) is introduced into this VF, not only can the CAMERA MENU be navigated at the VF, but also some action combination with the camera is realized.

3-2. Functions which are possible by this two-way communication

The below functions in combination with the camera are realized:

- The function for the camera setting menu (4-1. CAMERA MENU) activation and setting
- The function which drives some LEDs (EXT, <!>) which is mounted on VF and show some camera statuses
- The function that send "VF model name", "version" and so on to the camera
- ZOOM INDICATOR Please confirm [4-2.(1)].
- FOCUS INDICATOR Please confirm [4-2.(1)].
- ZOOMUP PEAKING Please confirm [4-2.(3)].

3-3. The initial start up process for the two-way communication

When the VF is connected with our camera, the two-way communication will start automatically.

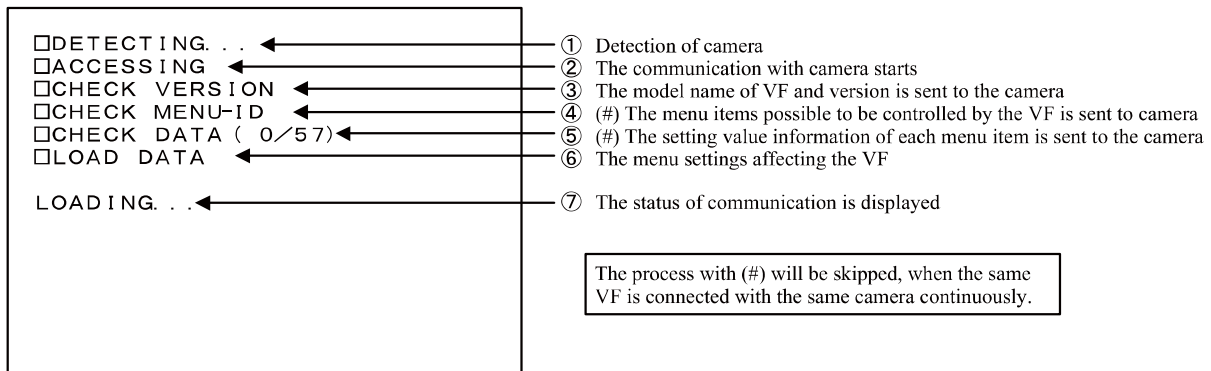

When the communication is finished correctly, the following message will be displayed, and the product can be used as it is.

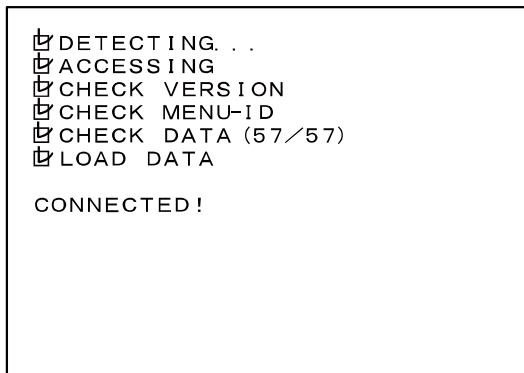

When the communication is not finished correctly, the message below will be displayed:

<pre>☒ DETECTING . . . ☒ ACCESSING ☒ CHECK VERSION ☒ CHECK MENU-ID ☐ CHECK DATA (56/57) ☐ LOAD DATA CONNECTION FAILURE! >RETRY CONNECTION ← >START-UP IN LIMITED MODE ←</pre>	<p>① The communication will start again from 1st step</p> <p>② VF will start up in LIMITED MODE without the communication function</p>
--	---

In this case, please retry the start up. Even after the retrial, when the communication can not be finished correctly, please select the LIMITED MODE to start up the product. In this case, some functions and combinations which are shown on [3-2. The function which are possible by this two-way communication] are not available.

<p># Concerning the TALLY function</p> <p>The Tally function is realized by a different line from the two-way communication one with camera. So, even when the product is started up in the LIMITED MODE, it should be possible for you to use the TALLY function. In this case, please confirm whether the TALLY function is available or not.</p>

4. Menu Operation

4-1. Menu List (CAMERA MENU)

CAMERA MENU	ASSIGN F1	FUNCTION Assigning a Setting for FUNCTION Switch F1
	ASSIGN F2	FUNCTION Assigning a Setting for FUNCTION Switch F2
	ASSIGN F3	FUNCTION Assigning a Setting for FUNCTION Switch F3
	VOLUME INDICATOR	ON/OFF Setting of MANUAL Volume Indicator Display
	ZOOM INDICATOR	ON/OFF Setting of Camera Zoom Indicator
	FOCUS INDICATOR	ON/OFF Setting of Camera Focus Indicator
	COLOR/MONO	COLOR/MONO Setting
	CHROMA UP	ON/OFF Setting of CHROMA UP
	GAMMA SELECT	Setting Gamma 1.4 / 1.8 / 2.2 / 2.6 / 3.0
	VIDEO MAG.	Setting of the magnification rate
	MAG.TIMER	Display Time Setting of Magnified Image
	CAPTURE DISPLAY	ON/OFF Setting of Captured Image Display
	DISP INTERVAL	Switchover Interval Setting of Capture Image
	FRONT TALLY	Setting of LED Brightness and Display OFF of Front Tally
	PEAKING	ON/OFF setting of PEAKING
	PEAKING MODE	Edge Direction Setting of PEAKING
	PEAK WIDTH	Edge Width Setting of PEAKING
	NOISE SUP	Coring Level Setting of PEAKING
	PEAKING UP	2x / 4x / 8x fold Setting of PEAKING level
	ZOOMUP PEAKING	ON/OFF Setting of ZOOMUP PEAKING Function
ZOOMUP PEAK-MAX	Setting the maximum value for ZOOMUP PEAKING at Tele-end	
ZOOMUP PEAK-MIN	Setting the minimum value for ZOOMUP PEAKING at Wide-end	
PEAKING COLOR	PEAKING Edge Color Setting	
MARKER ON/OFF	ON/OFF setting of MARKER Display	
MARKER SELECT	Setting of MAKER Type	
CENTER MARKER	ON/OFF setting of CENTER MARKER Display	
ASPECT MARKER	Setting of ASPECT MARKER Type	
SAFETY MARKER	80-100% (1% increment) setting of SAFETY MARKER	
SHADOW MODE	Display Mode setting of SHADOW	
SHADOW LEVEL	Shadow level setting	
MARKER COLOR	Marker Display Color setting	
MARKER LEVEL	MARKER Display Level setting	
USER MARKER	ON/OFF setting of USER MARKER Display	
MARKER LEVEL	USER MARKER Display Level setting	
SCENE SELECT	Marker scene file select	
MPU VERSION	MPU Version display	
H/W VERSION	Hardware Version display	



4-2. Functional description of the CAMERA MENU

◆The Camera Menu includes items related to the camera, as well as, the viewfinder. It will be displayed by pressing the MENU button for several seconds. In this manual only items relating to the VF are explained. For other items, please confirm in manual of your camera.

(1) TOP MENU

Item	Default	Setting value	Explanation
ASSIGN F1	MONO	described below	FUNCTION Assigning a Setting for FUNCTION Switch F1
ASSIGN F2	USMRK	described below	FUNCTION Assigning a Setting for FUNCTION Switch F2
ASSIGN F3	TALLY	described below	FUNCTION Assigning a Setting for FUNCTION Switch F3
VOLUME INDICATOR	OFF	ON, OFF	ON/OFF Setting of MANUAL Volume Indicator Display
ZOOM INDICATOR	OFF	ON, OFF	ON/OFF Setting of Camera Zoom Indicator
FOCUS INDICATOR	OFF	ON, OFF	ON/OFF Setting of Camera Focus Indicator

(1) ASSIGN F1~F3

Sets up the various functions to be assigned to Function Switches F1 to F3.

◆Items that can be set up:

- CAPTURE: Image capturing operation
- CHROMA: COLOR/MONO control of the display
- CPTDISP: ON/OFF control of CAPTURE operation
- GAMMA: Control of GAMMA
- MAG:ON/OFF control of Video MAG. function
- MARKER: ON/OFF control of markers
- MONO: COLOR/MONO control of the display
- NOISESUP: Control of Coring level
- PEAKING: ON/OFF control of PEAKING
- PEAKUP: Control of PEAKING level
- REVERSE: ON/OFF control of reversing the display
- SCENE: Selecting the individual scene files for user markers
- TALLY: OFF/LOW/HIGH setting of Front Tally
- USMRK: ON/OFF control of USER MARKER display
- ZMPEAK: ON/OFF control of ZOOMUP PEAKING

(2) VOLUME INDICATOR

Sets up ON/OFF of the manual volume indicator display. When adjusting PEAK, CONT, or BRIGHT volume, the setting level is displayed by the VOLUME INDICATOR on the Display.

(3) ZOOM INDICATOR

Sets up ON/OFF of the camera zoom position indicator display.

(4) FOCUS INDICATOR

Sets up ON/OFF of the camera focus position indicator display.

(2) VIDEO SETTING and TALLY MENU

Item	Default	Setting value	Explanation
COLOR/MONO	OFF	ON, OFF	COLOR/MONO Control Setting
CHROMA UP	OFF	ON, OFF	CHROMA UP Control Setting
GAMMA SELECT	GAMMA2.2	GAMMA 1.4, 1.8, 2.2, 2.6, 3.0	Setting Gamma 1.4/1.8/2.2/2.6/3.0
VIDEO MAG.	x2	x2, x4, x8	Setting of the magnification rate
MAG. TIMER	OFF	OFF, 1-7 sec	Display Time Setting of the Magnified Image
CAPTURE DISPLAY	OFF	ON, OFF	ON/OFF Setting of Captured Image Display
DISP. INTERVAL	1 FRAME	1, 2, 3, 5, 10, 30, 60 FRAME, HOLD	Switchover Interval Setting of the Captured Image
FRONT TALLY	LOW	LOW, HIGH, OFF	Setting the LED Brightness and Display OFF of the Front Tally

(1) COLOR/MONO

Sets up COLOR/MONO display.

* Setting [MONO] on a FUNCTION switch will enable ON/OFF switchover of COLOR/MONO.

(2) CHROMA UP

ON/OFF control of CHROMA UP. In the ON mode, the color level is increased.

(3) GAMMA SELECT

Sets up the Gamma value.

The normal Gamma setting is "2.2" as a standard. This is a function to increase the quality of the gradation in the dark section in images by lowering the Gamma value to "1.4".

By using this function, it becomes possible to support focusing in a dark scene or when focusing on a dark subject.

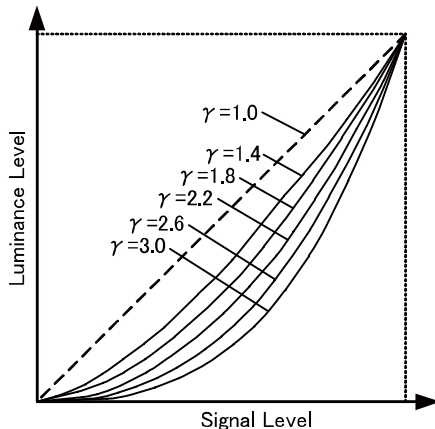
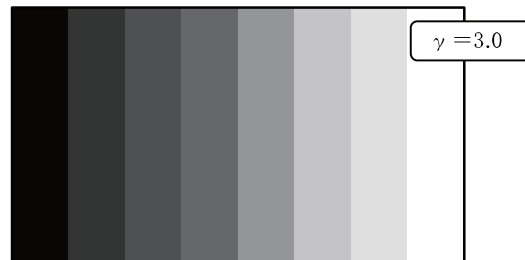
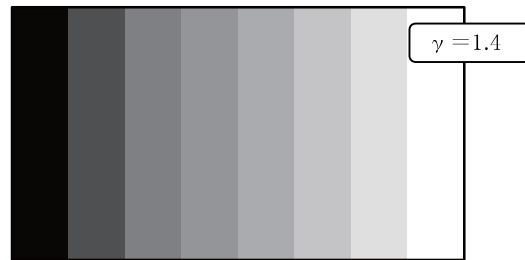

(4) VIDEO MAG. (Magnification)

Sets up the magnification rate of the image in the center area. The setting values that can be selected are x2, x4 and x8.

*Setting [MAG] on a FUNCTION switch will enable the operator to switch the video magnification function on/off. (Only when [MAG] is set on FUNCTION F1~F4, switching ON/OFF of this function is possible.)

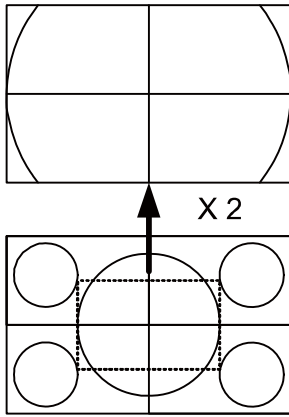

(5) MAG. TIMER

Sets up the timer for VIDEO MAG.

The setting is made here for specifying the length of time between when the magnification is turned ON and when it is automatically turned OFF.

The setting value is a value between 1 and 7 seconds and OFF.

If OFF is specified for the MAG. TIMER, the VIDEO MAG function will remain on indefinitely when MAG is set to the ON status.

(6) CAPTURE DISPLAY

Sets up ON/OFF of the Screen Capture function.

In the mode set up under item (7), switchover of the camera image and the captured image can be turned ON/OFF.

No switchover operation can be performed if the format of the Captured Image and that of the Camera Image differ. Make sure that both images are of the same format for executing switchover operation.

Setting [CAPDISP] on a FUNCTION switch will enable the camera Image and the preserved captured image to operate in the mode set under item (7).

(7) DISP. INTERVAL

Sets up the switchover interval between the captured image and the camera image in frame units.

The setting values that can be selected are 1 FRAME, 2 FRAMES, 3 FRAMES, 5 FRAMES, 10 FRAMES, 30 FRAMES, 60FRAMES, and HOLD (manual switchover).

Sets up the number of FRAMES after which switchover will occur automatically in the case of the FRAME mode.

In the HOLD mode, switchover will be executed manually.

(8) FRONT TALLY

Sets up the brightness and OFF for the Front Tally display. The setting can be made for LOW, HIGH or OFF.

* Setting [TALLY] on a FUNCTION switch will enable switching the setting to LOW, HIGH or OFF.

(3) PEAKING MENU

Item	Default	Setting value	Explanation
PEAKING	OFF	ON, OFF	ON/OFF Setting of PEAKING
PEAKING MODE	H&V	H&V, H-ONLY	Edge Direction Setting of PEAKING
PEAK WIDTH	1	1~4	Edge Width Setting of PEAKING
NOISE SUP.	0	0~9	Coring Level Setting of PEAKING
PEAKING UP	X1(OFF)	X1(OFF), X2, X4, X8	Setting of PEAKING Level
ZOOMUP PEAKING	OFF	ON, OFF	ON/OFF Setting of ZOOMUP PEAKING Function
ZOOMUP PEAK-MAX	100	MIN~100 (1 step)	Setting the maximum value for ZOOMUP PEAKING at the Tele-end
ZOOMUP PEAK-MIN	0	0~MAX (1 step)	Setting the minimum value for ZOOMUP PEAKING at the Wide-end
PEAKING COLOR	White	White, Yellow, Green, Red, Blue	PEAKING Edge Color Setting

(1) PEAKING

Sets up ON/OFF of the PEAKING function.

(2) PEAKING MODE

This sets the directions of the Peaking edge.

H&V: The Peaking edges are added in both the horizontal and vertical direction.

H-ONLY: The Peaking edges are added in the horizontal direction only.

When the setting is "H&V", a peaking edge flicker may be found in moving pictures. In this case, this phenomenon will be improved by changing the setting to "H-ONLY".

(3) PEAK WIDTH

Sets up the edge width of Peaking when Peaking is ON.

The setting value is a value between 1 (thin) and 4 (thick).

(4) NOISE SUP (NOISE SUPPRESS)

Sets up the Coring Level of Peaking when Peaking is ON.

This is a function for cutting off the small edges below the specified threshold value. In other words, this function eliminates the edge elements attached to the noise in images, allowing a clearer peaking to be realized.

It should be remembered, however, that some fine edges normally attached to the image will also be cut off.

*Setting [CORING] on a FUNCTION switch will enable switching of the Coring Level between 0 and 9.

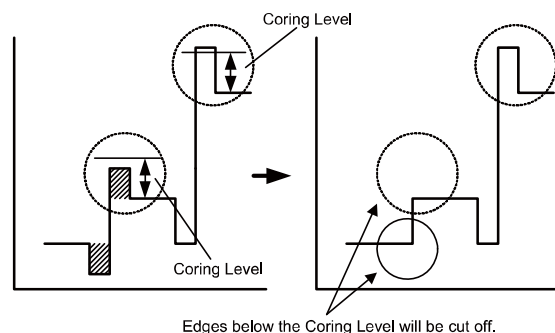

(5) PEAKING UP

When Peaking is ON, sets up the magnification of the Peaking Level.

By increasing the magnification, it will become easier for peaking to attach to those portions that are difficult for edges to attach because of a small difference in brightness.

In this case, however, peaking will attach even to the noise in the image. Therefore, a clear peaking can be realized by using this feature in conjunction with the preceding feature described under (4) NOISE SUP.

The setting values that can be selected are OFF (×1), ×2, ×4, and ×8.

*Setting [PEAKUP] on a FUNCTION switch will enable switching of the Peaking Magnification.

(6) ZOOMUP PEAKING

When Peaking is ON, the ON/OFF setting for the function of varying the Peaking amount in conjunction with the zoom position of the camera is carried out here.

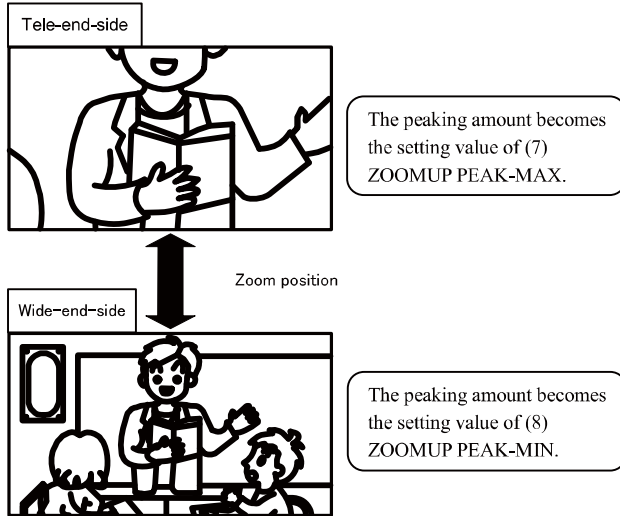

*Setting [ZM-PEAK] on a FUNCTION switch will enable ON/OFF control of ZOOMUP PEAKING.

(7) ZOOMUP PEAK-MAX

When ZOOMUP PEAKING is ON, you can set the value of the peaking amount at the Tele-end from the setting value in (8) to 100.

(8) ZOOMUP PEAK-MIN

When ZOOMUP PEAKING is ON, you can set the value of the peaking amount at the Wide-end from 0 to the setting value in (7).

(9) PEAKING COLOR

The color for peaking can be selected among White, Yellow, Green, Red and Blue.

(4) MARKER MENU

Item	Default	Setting value	Explanation
MARKER ON/OFF	OFF	ON, OFF	ON/OFF setting of MARKER Display
MARKER SELECT	SAFETY	described below	Setting of MAKER Type
CENTER MARKER	OFF	OFF, TYPE-A, B	ON/OFF setting of CENTER MARKER Display
ASPECT MARKER	4:3	4:3, 13:9, 14:9, 15:9	Setting of ASPECT MARKER Type
SAFETY MARKER	80%	80~100%	80-100% (1% increment) setting of SAFETY MARKER
SHADOW MODE	OFF	OFF, SHADOW, MRK+SHD	Display Mode setting of SHADOW
SHADOW LEVEL	60%	60, 40, 20%	Shadow level setting
MARKER COLOR	White	white, yellow, cyan, green, magenta, red and blue	Marker Display Color setting
MARKER LEVEL	60%	20, 40, 60, 80, 100%	MARKER Display Level setting

(1) MARKER ON/OFF

Sets up ON/OFF of the Marker Display.

* Setting [MARKER] on a FUNCTION switch will enable ON/OFF control of the MARKER.

(2) MARKER SELECT

Switches the Marker to be displayed.

The marker types that can be selected are SAFETY, CROSS5, CROSS10, C.CROSS, ASPECT, ASP+SAF, FRM+SAFE, and CENTER.

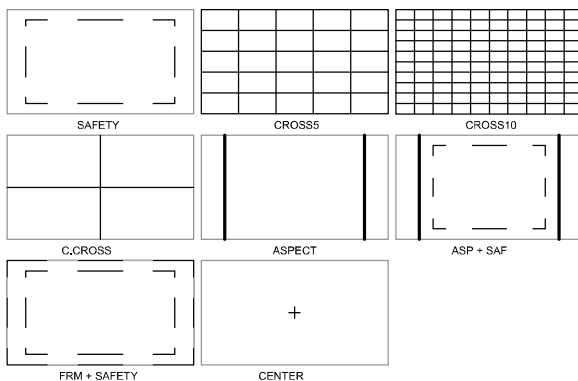

(3) CENTER MARKER

Turns ON/OFF the Center Marker display.

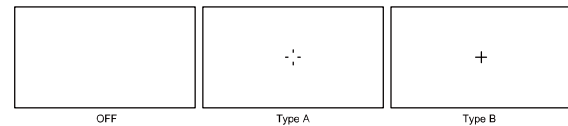

(4) ASPECT MARKER

Switches the Aspect of the Aspect Marker.

The ratios that can be selected are 4:3, 13:9, 14:9, and 15:9.

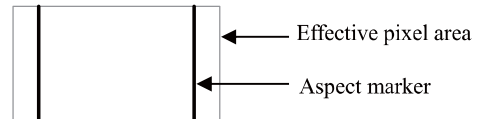

(5) SAFETY MARKER

Switches the Safety Area of the Safety Marker.

The area that can be selected is between 80% and 100% (set in 1% increments).

<In the case of SAFETY MARKER Display>

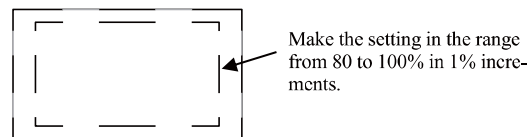

<In the case of SHADOW display>

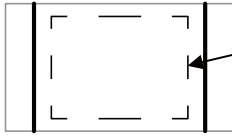

Setting is made in the range from 80 to 100% in 1% increments.

(6) SHADOW MODE

Switches the Display mode of the Aspect Marker.

The setting values that can be selected are OFF, SHADOW and MRK+SHD.

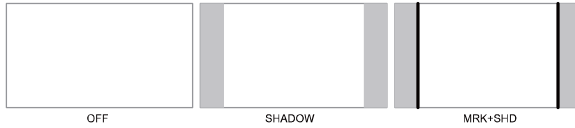

(7) SHADOW LEVEL

Switches the Shadow Level of the Aspect Marker.

The levels that can be selected are 0% (black), 20%, 40%, 60%.

(8) MARKER COLOR

Sets up the Marker Color.

The feature is in common with Aspect Marker, Safety Marker, Cross-hatch Marker, and Center Marker.

The colors that can be selected are White, Yellow, Cyan, Green, Magenta, Red and Blue

(9) MARKER LEVEL

Switches the brightness level of the Marker.

The levels that can be selected are 20%, 40%, 60%, 80% and 100%.

To prevent burn-in from occurring, it is recommended that the unit should be used at a low brightness level as much as possible.

(5) USER MARKER MENU

Item	Default	Setting value	Explanation
USER MARKER	OFF	OFF, ON	ON/OFF setting of the USER MARKER Display
MARKER LEVEL	60%	20, 40, 60, 80, 100%	USER MARKER Display Level setting
SCENE SELECT	SCENE1	SCENE1~SCENE5	Select Marker scene file

(1) USER MARKER

Sets ON/OFF of the USER MARKER display.

- Setting [USRMRK] on a FUNCTION switch will enable ON/OFF control of the USER MARKER.

(2) MARKER LEVEL

Sets the brightness level of the USER MARKER.

The levels that can be selected are 20%, 40%, 60%, 80% and 100%.

(3) SCENE SELECT

Sets up the USER MARKER to be displayed from among SCENE1 through 5.

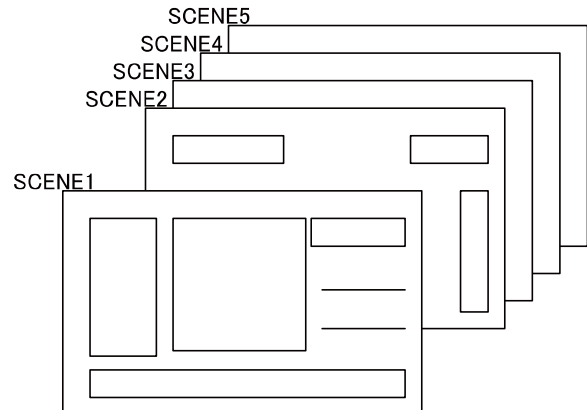

*Setting [SCENE] on a FUNCTION switch will enable selecting of individual SCENES of the USER MARKER.

(6) INFO/UPDATE MENU

Item	Default	Setting value	Explanation
MPU VERSION	—	—	MPU Version display
H/W VERSION	—	—	Hardware Version display

(1) MPU VERSION

Displays the MPU version.

(2) H/W VERSION

Displays the Hard Ware version.

4-3. Menu List (VF MENU)

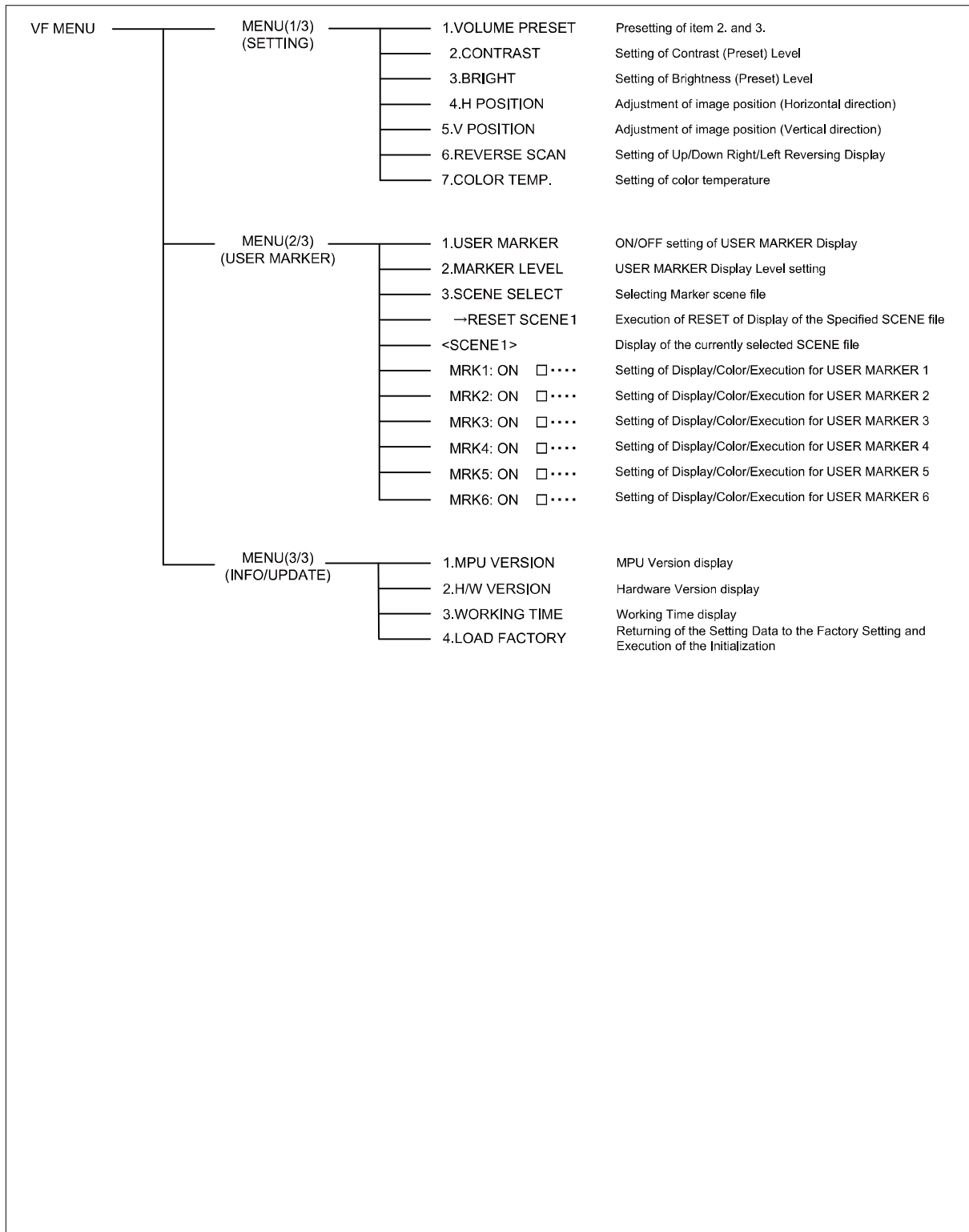

4-4. How to operate and functional description of the menu (VF MENU)

◆ Basic operation of the menu switch

MENU operation by using the MENU switch is explained below.

① Changing MENU pages

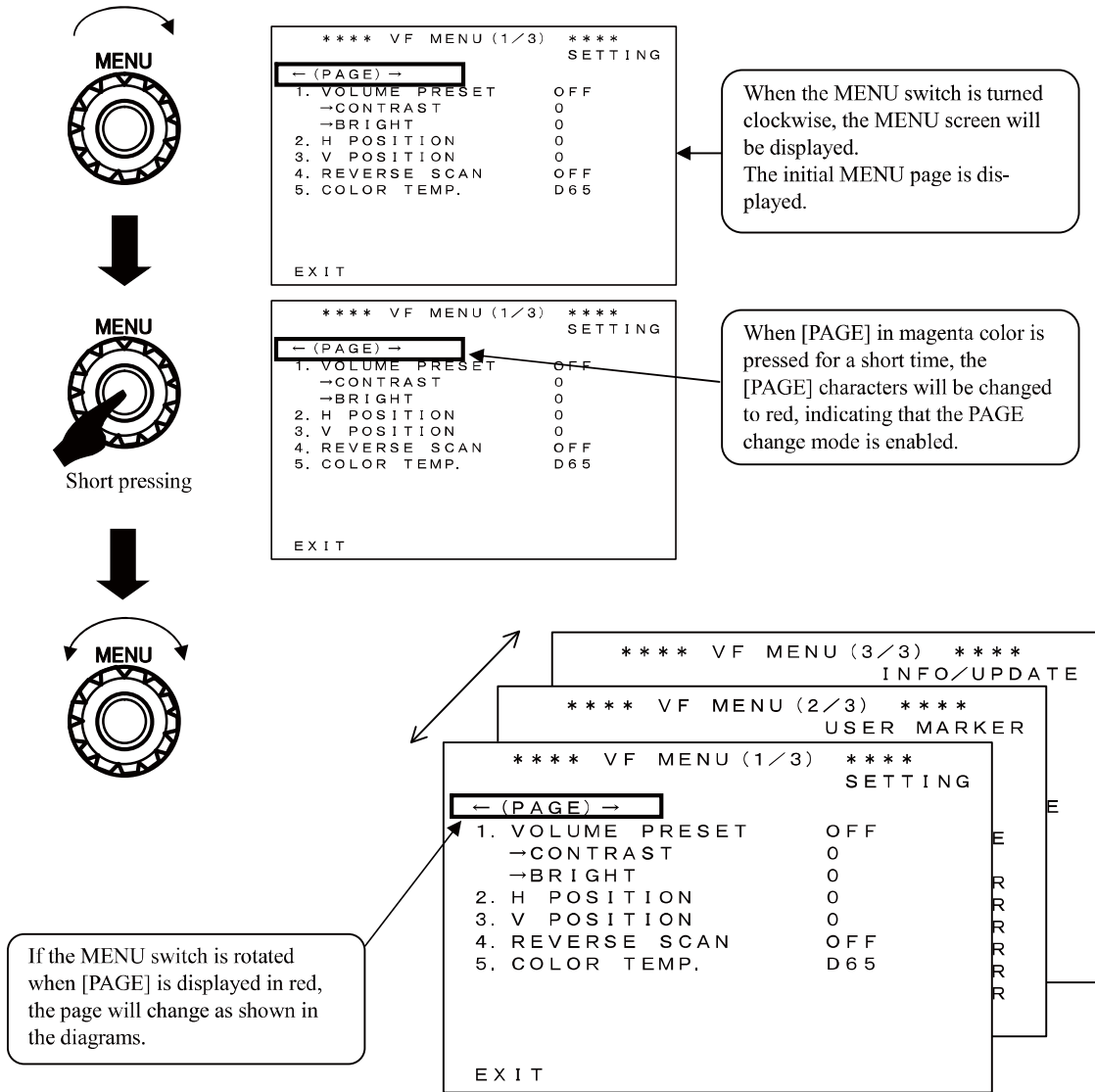

② Setting the MENU

When characters of [PAGE] are displayed in red after the MENU screen display has started, pressing the MENU switch will cause the color of [PAGE] to turn to magenta. This indicates that the setting mode within the page is enabled, permitting changes to be made.

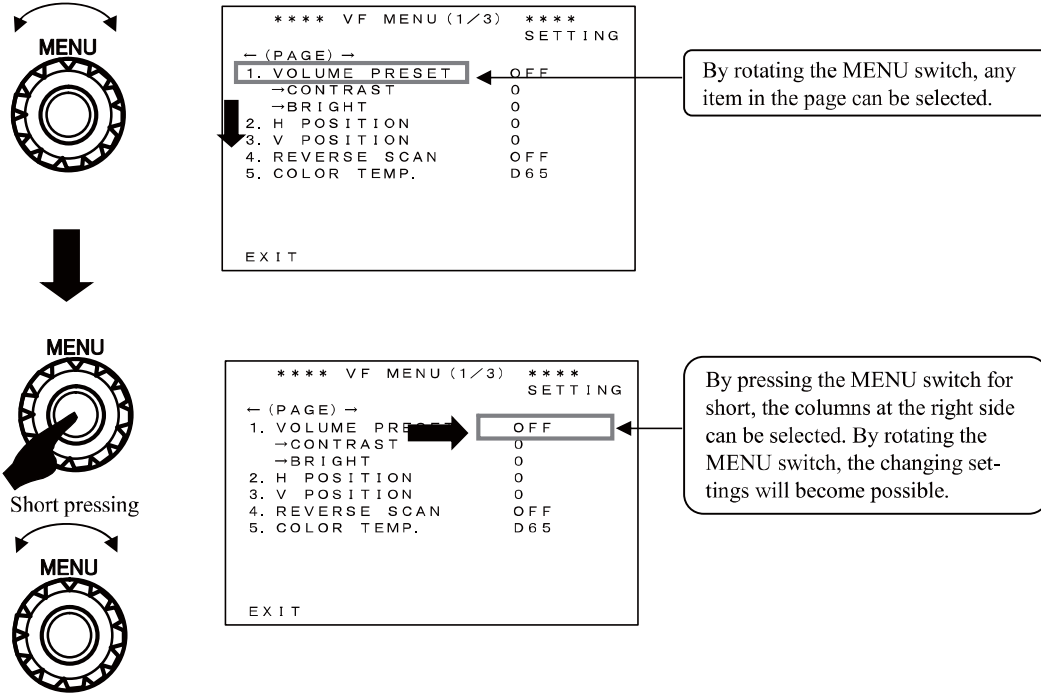

③ Turning OFF the MENU screen

To erase the MENU, press the MENU switch for a long time or press [EXIT] for a short time.

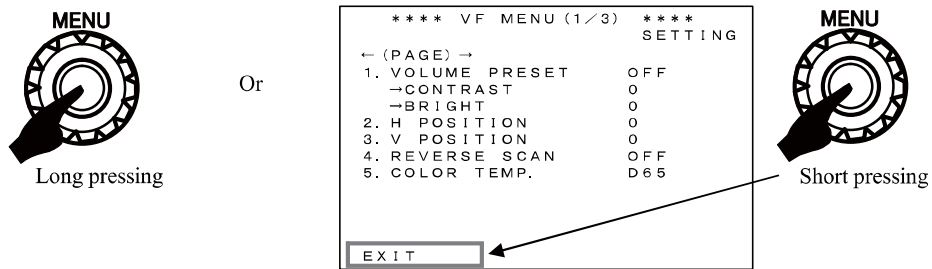

(1) MENU (1/3) SETTING

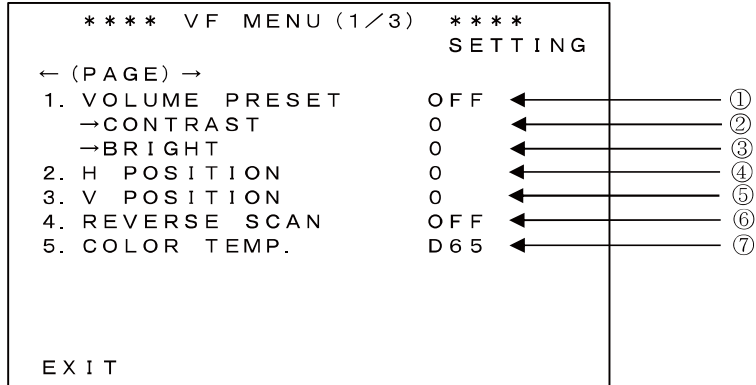

① VOLUME PRESET

Volume Preset On allows setting the value of ② and ③ respectively as the preset values.

The default value is "OFF".

② CONTRAST

Sets up the Contrast PRESET value.
The setting is a value between -10 and +10.

The default value is "0".

③ BRIGHT

Sets up the Brightness PRESET value (when LED of the **BRIGHT volume** is OFF).
The setting is a value between -10 and +10.

The default value is "0".

④ H POSITION

Sets up the adjustment of the image position for horizontal direction. The setting is a value between -10 and +10.

⑤ V POSITION

Sets up the adjustment of the image position for vertical direction. The setting is a value between -10 and +10.

⑥ REVERSE SCAN

Sets up the Image Reversing Display function (rotation by 180°).
The setting that can be selected is OFF or ON.

The default value is "OFF".

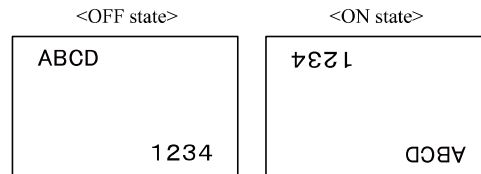

⑦ COLOR TEMP.

Sets up the COLOR Temperature.
The setting value is "D65" or "PANEL".
When this is set on "D65", the color temperature will be set to 6500K. When on "PANEL", the nature color temperature of the panel will be realized

The default value is "D65". ("D65" means 6500K.)

(2) VF MENU (2/3) USER MARKER

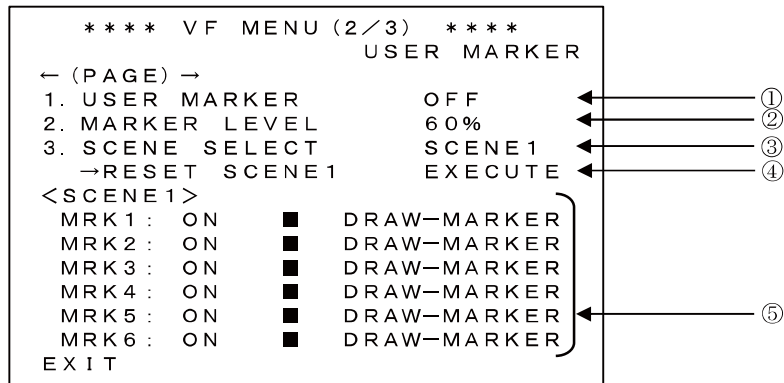

① USER MARKER

Sets up ON/OFF of the USER MARKER display.

- Setting [USRMRK] on a FUNCTION switch will enable ON/OFF control of the USER MARKER.

② MARKER LEVEL

Sets up the brightness level of the USER MARKER.

The levels that can be selected are 20%, 40%, 60%, 80% and 100%.

③ SCENE SELECT

Sets up the USER MARKER to be displayed from among SCENE1 through 5.

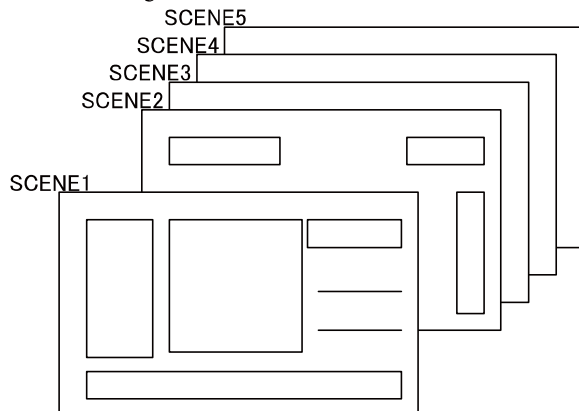

- Setting [SCENE] on a FUNCTION switch will enable switchover of individual SCENES of the USER MARKER.

④ →RESET

Erases the USER MARKERS being drawn in individual SCENES.

First, select the SCENE to be erased according to item 3. Then press the MENU switch at [RESET SCENE1]. (This case means that SCENE1 is selected at item 3.)

At this time, a confirmation message will be displayed at the next MENU to check if it is all right to erase the selected SCENE.

By selecting OK at this time and pressing the MENU switch, the erasure of the drawing will be executed.

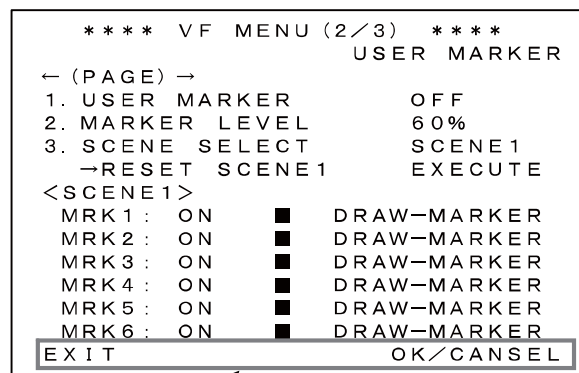

The confirmation message

⑤ MARKER1~6

In a single scene, 6 types of User Marker can be set for making individual ON/OFF settings, display color settings (for white, yellow, cyan, green, magenta, red, and blue), and the setting for drawing.

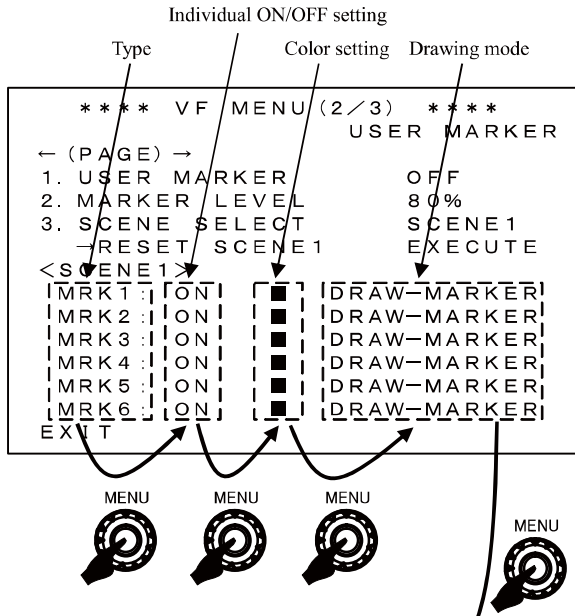

◆USER MARKER Drawing Mode

The USER MARKER drawing mode is enabled and drawing actions are performed.

Numbers indicate coordinates of pixels in 960 × 540.

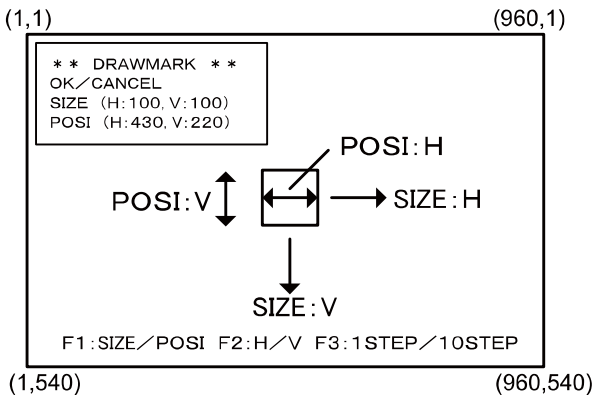

The default SIZE is “(100,100)”.

The default POSI is “(430, 220)”.

●Selection of drawing item and how to draw the USER MARKER

Before you start drawing, the drawing item will be selected by turning the MENU switch and you can decide the drawing item by pressing the MENU switch. The value will be selected by turning the MENU switch and that value can be decided by pressing the MENU switch.

Regarding the drawing items, you can change them cyclically like below by turning the MENU switch:

SIZE:H→SIZE:V→POSI:H→POSI:V→SIZE:H→...

● Drawing for SIZE: H

Horizontal width of a BOX or a LINE can be changed by turning the MENU switch. And also, every time when you click the toggle switch F3, you can change this drawing width unit to 1 or 10 pixels cyclically.

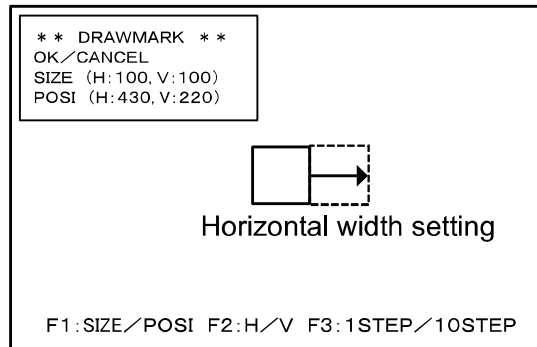

● Drawing for SIZE: V

Vertical width of a BOX or a LINE can be changed by turning the MENU switch. And also, every time when you click the toggle switch F3, you can change this drawing width unit to 1 or 10 pixels cyclically.

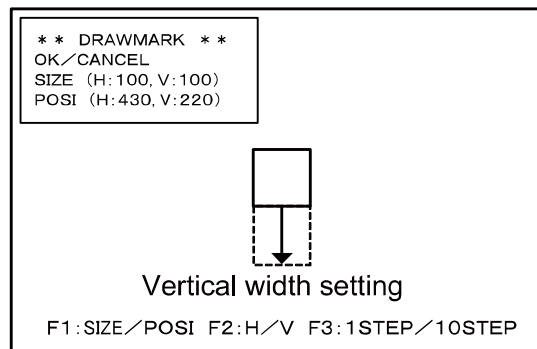

- Drawing for POSI: H

A BOX or a LINE can be moved in the horizontal direction by turning the MENU switch.

And also, every time when you click the toggle switch F3, you can change the position movement unit to 1 or 10 pixels cyclically.

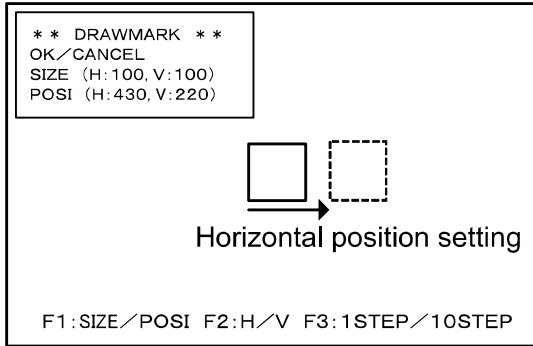

- Drawing for POSI: V

A BOX or a LINE can be moved in the vertical direction by turning the MENU switch.

And also, every time when you click the toggle switch F3, you can change the position movement unit to 1 or 10 pixels cyclically.

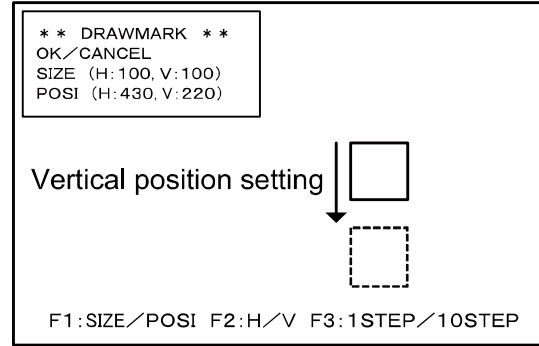

- How to use F1 and F2 toggle switches during the drawing of MARKER

During your drawing MAKER, every time when you click the toggle switch F1 or F2, you can change the drawing item, SIZE and POSI or H and V respectively easily.

F1 : SIZE ⇔ POSI
 F2 : H ⇔ V

(3) VF MENU (3/3) INFO / UPDATE

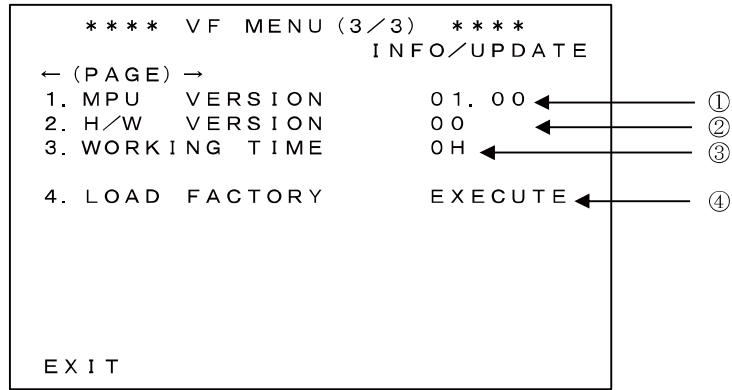

① MPU VERSION

Displays the MPU version.

③ WORKING TIME

Displays the accumulated Working Time in which the Viewfinder has been operated in increments of hours.

② H/W VERSION

Display the Hard Ware version

④ LOAD FACTORY

Returns all settings to the Factory Settings.

5. Specifications

5-1. General specifications

(1) Power-supply voltage

+12 V DC (10.5~18 V)

(2) Power consumption

4.0 W (Color bar (1080i/59.94), Heater OFF)

(3) Operating ambient temperature/humidity:

Storage ambient temperature/humidity

In operation: -20°C ~ +45°C

20%~85% (non-condensing)

For storage: -20°C ~ +60°C

20%~85% (non-condensing)

Maximum wet-bulb temperature: 29°C

(4) Outside dimensions

Main unit: 215 (W) × 72(H) × 156 (D) mm

(not including protrusions and the mounting bracket)

(5) Mass

760 g or less

(6) Accessories

The mounting bracket (1)

Operation manual (1)

5-2. Rated performance

(1) Camera video signal

a) Input terminal

Input: camera interface 1 connection

b) Input signal format (automatic recognition)

1080i/ 59.94, 50

1080p/ 29.97, 25, 24, 23.98

720p/ 59.94, 50

1080PsF/ 29.97, 25, 24, 23.98

c) Input signal

LVDS

d) Transmission system

Differential signal

e) Quantifying bit number

10 bits

f) Input impedance

100 Ω

g) Transmission speed

1.485 Gb/s

(2) Camera communication signal

a) Input terminal

Input: camera interface 1 connection

b) Format

RS-422

c) Transmission speed

38400 b/s

5-3. LCD panel specifications

(1) Pixels number

960(H) x 540 (V) dot

(2) Pixel pitch

0.0155mm (W) x 0.0465mm (H)

(3) Screen size (display area)

44.64mm x 25.11mm (51.2mm diagonal)

(4) Screen brightness (Only LCD specification)

220cd/m²

(5) Drive method

a-TFT active matrix, non-interlace,
normally white

(6) Pixel arrangement

RGB vertical stripe

(7) Response speed

Ton+Toff: 16ms (typ.) (Ta=25°C)

(8) Contrast ratio

200:1 (Typ.)

(9) Number of display colors

16.77 million colors (Each of RGB at 8 bits)

(10) Angle of visibility

45° (up and down, left and right) (contrast ratio 10:1 more)

6. Functions

6-1. Front operation

(1) Menu Switch

Rotary encoder (Moving cursor and enter)

(2) Assignable switches (F1 ~ F3)

F1 ~ F3 can be assigned to a function by the MENU.

(3) Volume

PEAKING, CONTRAST, BRIGHTNESS

6-2. Marker function

(1) Center marker

- Type-A (with a center intersection point)
- Type-B (without a center intersection point)

(2) Safety marker

- a) Types
 - Safety area marker (80% ~ 100%)
 - 5 × 5 division cross-hatch
 - 10 × 10 division cross-hatch
 - Cross
 - Aspect marker (15:9/4:9/13:9/4:3)
 - Aspect marker + safety marker
- b) Marker level
 - Setting in 5 steps of 20%, 40%, 60%, 80% and 100%

6-3. Shadow function

Function for shadowing outside the aspect marker area

a) Types

- Various aspect markers + shadows
- Various aspect markers only
- Shadows only

b) Shadow contrast level

- Setting in 3 steps of 20%, 40%, 60%

6-4. User marker function

Function for the user to draw a box at any location with any size in increments of pixels.

- a) Number of scenes: 5
 - b) Number of types of markers per scene: 6
 - c) Color: 7 colors (Individual settings allowed)
 - d) Size allowed for drawing: 960 × 540 pixels
 - e) Drawing method: By using the switch or a USB mouse
- * Patent registered

6-5. Video-MAG. function

The center area of input video can be magnified by x2, x4 and x8. Even when the high definition LCD is used, the visibility of pixels is improved and it is easier to confirm the focusing.

6-6. Peaking function

(1) Edge width

The setting value is 1 (thin) ~ 4 (thick).

(2) NOISE SUP

This is a function for cutting off the edges below the specified threshold value in the edge elements of images. In other words, this function eliminates the edge elements attached to the noise elements in images.

(3) PEAKING UP

The amplification of peaking level can be set on x1, x2, x4 and x8 according to the difference of luminance. The peaking will be effect for the pixels whose difference of luminance is low.

(4) ZOOMUP PEAKING

The peaking amount can be variable by being linked with zoom position. The peaking amount will be maximum at the tele-end and minimum at the wide-end.

(5) COLOR PEAKING

This function adds color on the edge of video when the peaking setting is ON. It will be easy to obtain fine focusing.

7. Applicable Standards

7-1. Radio noise

- FCC Class-A
- EN55103-1 E4
- EN55103-2 E4

7-2. Environmental standards

Compliant with RoHS Directive

◆Precautions

- * Please understand that the specifications and the appearance of this product are subject to changes without notice for improvements.
- * Missing or bright spots may occur on this product at a rate of 0.01% or lower. Please understand that this phenomenon is not a malfunction of the product.

8. Exterior Drawing

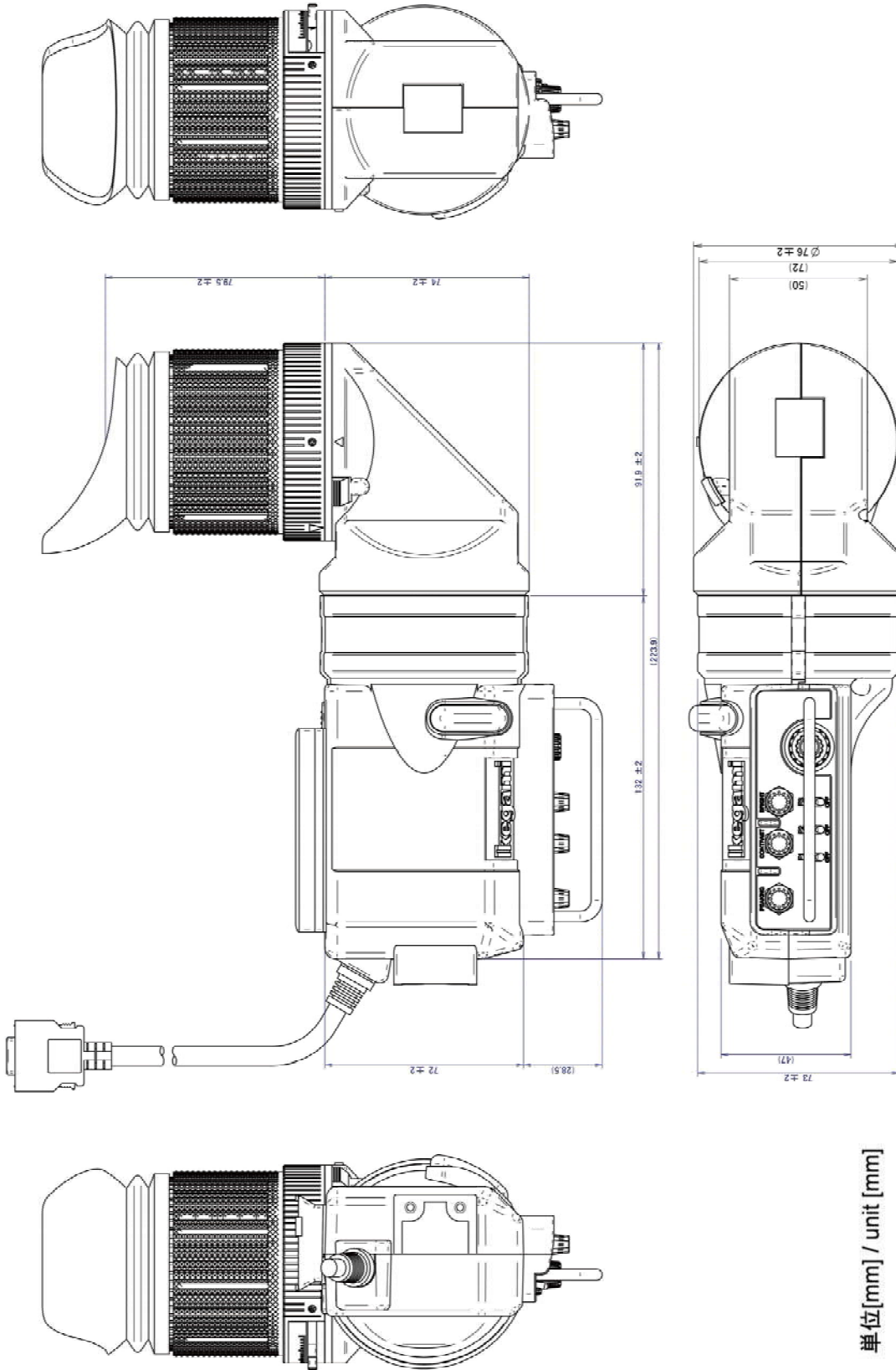

Ikegami

池上通信機株式会社

本社: 〒146-8567 東京都大田区池上 5-6-16 TEL(03)5700-1111(大代)
5-6-16, Ikegami, Ohta-ku, Tokyo, 146-8567 Japan
Phone: 03-5700-1111, Fax: 03-5700-1137 <http://www.ikegami.co.jp>

ご連絡先

□国内営業グループ	〒146-8567 東京都大田区池上 5-6-16	電話 03-5748-2211
□大阪支店	〒564-0052 大阪府吹田市広芝町 9-6 第1江坂池上ビル	電話 06-6389-4466
□名古屋営業所	〒465-0051 愛知県名古屋市中東区社が丘 1-1506 加藤第2ビル	電話 052-705-6521
□福岡営業所	〒812-0016 福岡県福岡市博多区博多駅南 3-7-10 STビル	電話 092-451-2521
□仙台営業所	〒983-0869 宮城県仙台市宮城野区鉄砲町西 1-14 富士フィルム仙台ビル	電話 022-292-2420
□札幌営業所	〒060-0051 北海道札幌市中央区南一条東1-3 パークイースト札幌	電話 011-231-8218
□テクノイケガミ	〒210-0826 神奈川県川崎市川崎区塩浜 4-13-15	電話 044-270-5471
□テクノイケガミ(大阪カスタマサービス)	〒564-0052 大阪府吹田市広芝町 9-6 第1江坂池上ビル	電話 06-6389-2051

□Ikegami Electronics (U.S.A.), Inc.

37 Brook Avenue, Maywood, New Jersey 07607, U.S.A.

Phone: (201) 368-9171, FAX (201) 569-1626

www.ikegami.com

□Ikegami Electronics (Europe) GmbH

Ikegami Strasse 1, D-41460 Neuss, Germany

Phone: 02131-123-0, FAX 02131-102820

www.ikegami.de

□Ikegami Electronics (Europe) GmbH (U.K. Branch)

1 Windmill Business Village, Brooklands Close, Sunbury on Thames, TW16 7DY, England

Phone: 01932-769700 FAX 01932-769710

www.ikegami.co.uk

□Ikegami Electronics Asia Pacific Pte.LTD.

1 Tampines Central 5, #3-3 CPF Tampines Building, Singapore 529508

Phone: (+65) 6260-8820 FAX:(+65) 6260-8896

本書の全部または一部を無断で転載、複写することを禁じます。
改良のためお断りなく、製品の仕様を変更することがあります。

MODEL VFL201D
Digital I/F LCD Color Viewfinder
オペレーションマニュアル

第二版: 2016年 12月

発行: 池上通信機株式会社
© 2016年 12月 池上通信機株式会社

MODEL VFL201D
Digital I/F LCD Color Viewfinder
Operation Manual

2nd Edition: December 2016

Published in Ikegami Factory of Ikegami Tsushinki Co., Ltd.
© December 2016 Ikegami Tsushinki Co., Ltd.

Ikegami