



**NETWORK
TECHNOLOGIES
INCORPORATED**

1275 Danner Dr Tel:330-562-7070
Aurora, OH 44202 Fax:330-562-1999
www.networktechinc.com

XTENDEX® Series

600 FOOT EXTENDERS

Installation and Operation Manual



**ST-C5KVM-600
PS/2 KVM Extender**



TRADEMARK

XTENDEX is a registered trademark of Network Technologies Inc in the U.S. and other countries.

COPYRIGHT

Copyright © 2003, 2021 by Network Technologies Inc. All rights reserved. No part of this publication may be reproduced, stored in a retrieval system, or transmitted, in any form or by any means, electronic, mechanical, photocopying, recording, or otherwise, without the prior written consent of Network Technologies Inc, 1275 Danner Drive, Aurora, Ohio 44202.

CHANGES

The material in this guide is for information only and is subject to change without notice. Network Technologies Inc reserves the right to make changes in the product design without reservation and without notification to its users.

Note: *Shielded CAT 5,5e, or 6 cable must be used to connect to LOCAL and REMOTE units in order to meet CE emission and immunity requirements.*

Note: *CATx connection cable used between NTI XTENDEX Series Local and Remote or any XTENDEX Series products should not be run underground, outdoors or between buildings.*

WARNING: *Outdoor or underground runs of CATX cable could be dangerous and will void the warranty.*

WARNING: *The CATx connection cable used between NTI XTENDEX Series Local and Remote or any XTENDEX Series products must be wired straight through (pin 1 to pin 1, pin 2 to pin 2, etc.) The use of a CROSSOVER CABLE will damage the extender and void your warranty.*

CE Statement

We, Network Technologies Inc, declare under our sole responsibility that the ST-C5KVM-600, ST-C5KVMRS-600, ST-C5KVMA-600, ST-C5V-600, ST-C5VRS-600 and ST-C5VA-600 is in conformity with European Standard EN55022.

External Ground

This product is equipped with grounding hardware to prevent interference from sources of electrical noise that could interfere with the normal operation of the XTENDEX or damage it. Use either the crimp-on lug or solder terminal to secure a properly grounded wire (connected to earth ground) to the XTENDEX.

Failure to make this connection may result in poor video quality at the connected monitor(s).

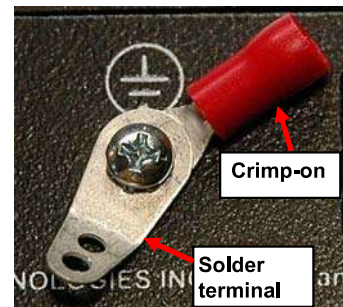

TABLE OF CONTENTS

Introduction	1
Materials	2
Features and Functions	4
Limitations	6
Preparation for Installation	7
Installation	8
Installing The Local Unit (models with VGA video connectors).....	8
Installing the Local Unit (models with only KM connectors).....	10
Connect The CATx Cable.....	11
Installing The Remote Unit (models with VGA video connectors).....	11
Installing The Remote Unit (models with only KM connectors).....	14
Connect the CATx cable.....	14
Models With One Remote.....	14
Models With Two Remotes.....	15
Plug-in and Boot Up.....	16
Video Quality	17
Command Mode.....	18
Enter Command Mode.....	18
Update DDC at Remote.....	18
Update DDC at Local.....	18
Mix DDC.....	19
Reset Defaults.....	19
Exit Command Mode.....	19
Other DDC Support.....	19
Automatic EDID Updates.....	19
Manual EDID Capture.....	20
More About DDC.....	21
Technical Specifications	22
Interconnection Cable Wiring Method	23
Troubleshooting	24
Index	25
Warranty Information	25

TABLE OF FIGURES

Figure 1- Connect the Local Unit with VGA video and RS232 support to the CPU.....	8
Figure 2- Connect the Local Unit with Audio support to the CPU.....	9
Figure 3- Connect the local user to the XTENDEX Local Unit.....	9
Figure 4- Connect stereo speakers to XTENDEX Local Unit with audio support.....	10
Figure 5- Connect Local Unit with only keyboard and mouse support.....	10
Figure 6- Connect CATx cable to Local Unit.....	11
Figure 7- Connect the Extended Components to the Remote Unit.....	12
Figure 8- Connect speakers to the Remote Unit.....	13
Figure 9- Connect keyboard and mouse to Remote Unit.....	14
Figure 10- Connect the CATx cable to the Remote Unit.....	14
Figure 11- Connect CATx cables between Local and Remote Units.....	15
Figure 12- Connect the AC adapter to the Remote Unit.....	16
Figure 13- Buttons for video quality adjustment.....	17
Figure 14- DDC Update Button on Local with Dual Remote Support.....	20
Figure 15- Connect remote monitor for EDID capture.....	20
Figure 16- View looking into RJ45 female.....	23

INTRODUCTION

The XTENDEX Series CAT5 Extender (XTENDEX) is designed to enable one CPU to be controlled by two users, one local and one remote. The remote user can be located as much as 600 feet away from a PS/2 CPU via Category 5/5e/6 (CATx) unshielded twisted-pair cable. The local user will be located near the CPU.

Options:

Local Supporting Two Remotes- The XTENDEX series 600 foot PS/2 extender is available supporting two Remote Units from a single Local Unit if needed. See chart below for available models and features. When ordering the XTENDEX with dual Remote support, Remote Units are ordered separately.

The XTENDEX Series Extender is extremely simple to install and has been thoroughly tested to insure reliable performance. Through the use of Category 5/5e/6 cable it is possible to economically increase the flexibility of a computer system. Here are some of the features and ways this can benefit any workplace:

- Allows the placement of computer peripherals (monitor, keyboard, and mouse) in a location where only these parts are needed without having the CPU there too, taking up valuable space
- Allows a PS/2 CPU to be accessed by both a local and remote user (up to 600 feet away)(most models-see chart below)
- Compatible with XGA and VGA systems
- Provides crisp and clear resolution up to 1024 x 768 @ 600 feet (see page 21 for more details)
- Compatible with all NTI switches and splitters, enabling the joining of products to create a system that satisfies all networking needs
- Video quality adjustment, for varying lengths of cable, is automatic (most models, see below and page 20) providing optimum image quality
- Audio frequency response is 20Hz to 20Khz, ± 1dB (models with audio support only)
- Digital transmission of audio signals reduces any loss in quality (models with audio support only)

This manual covers each of the XTENDEX Series CAT5-600 Extender models offered. Some features described in this manual are available in some models and not in others. The chart below shows the features supported in each:

Model	Video	Kybd/ Mse Support	Audio Support	# of Remotes Supported	RS232 Support	Video Quality Adjustment
ST-C5KVM-600	VGA	Yes	No	1	No	Automatic
ST-C5KVMA-600	VGA	Yes	Yes	1	No	Automatic
ST-C5KVMRS-600	VGA	Yes	No	1	Yes	Automatic
ST-C5V-600	VGA	No	No	1	No	Manual
ST-C5VA-600	VGA	No	Yes	1	No	Automatic
ST-C5VRS-600	VGA	No	No	1	Yes	Automatic
ST-2C5V-L-600	VGA	No	No	2	No	Manual
ST-2C5VA-L-600	VGA	No	Yes	2	No	Automatic
ST-C5KVMRS-600-SCI	VGA	Yes	No	1	Yes	Manual
ST-C5KM-600	NO	On Remote only	No	1	No	Not Applicable

Note: Models shaded in blue (ST-2C5V(A)-L-600) provide Remote Unit-only support for devices, no Local Unit support.

MATERIALS

Materials supplied with ST-C5xxxx-600:

- ✓ NTI XTENDEX Local Unit
- ✓ NTI XTENDEX Remote Unit
- ✓ 2- 120VAC or 240VAC at 50 or 60Hz-9VDC/1.0A AC Adapters (only 1 ST-C5KM-600)

Materials supplied with ST-2C5xxxx-L-600:

- ✓ NTI XTENDEX Local Unit
- ✓ 1- 120VAC or 240VAC at 50 or 60Hz-9VDC/1.0A AC Adapter

Additional materials may need to be ordered, depending upon the configuration:

- CAT5/5e/6 unshielded twisted-pair cable(s) terminated with RJ45 connectors wired straight thru- pin 1 to pin 1, etc. (see pg. 8 for proper EIA/TIA 568 B wiring method)

Note: *Shielded CAT5, 5e, or 6 cable must be used to connect to LOCAL and REMOTE units in order to meet CE emission requirements.*

- Cable(s) needed if Local Unit will be located further than 15" from the CPU

Model	Cable(s) needed
ST-C5KVM-600	VKMEXT-xx (xx= 3/6/10/15/25/35/50/75/100 feet)
ST-C5KVMRS-600	VKMEXT-xx and DINT-xx
ST-C5KVMA-600	VKMEXT-xx and SA-xx-MF
ST-C5V-600	VEXT-xx
ST-C5VRS-600	VEXT-xx and DINT-xx
ST-C5VA-600	VEXT-xx and SA-xx-MF
ST-C5KM-600	VVKINT-xx or VVKEXT-xx

The chart above also applies to Local Unit models with support for two remotes.

Cables Lengths Available

Cable	xx= Length in feet
VKMEXT-xx	3/6/10/15/25/35/50/75/100
VEXT-xx	3/6/10/15/25/35/50/75/100
DINT-xx	6/10/15
SA-xx-MF	6/12/25/50
VVKINT-xx	3/6/10/15/25
VVKEXT-xx	35/50/75/100

Legend:

xx= 3, 6, 10, 15 or 25 foot length

MM= cables have male connectors on both ends (except for the DB9) and are only used with Local Units

Note: *If two users will be connected (one local and one remote), two of the cables without the "MM" (i.e. VMCTINT-xx) will be needed.*

Contact your nearest NTI distributor or NTI directly for all of your KVM needs at 800-RGB-TECH (800-742-8324) in US & Canada or 330-562-7070 (Worldwide) or at our website at <http://www.networktechinc.com> and we will be happy to be of assistance.

FEATURES AND FUNCTIONS

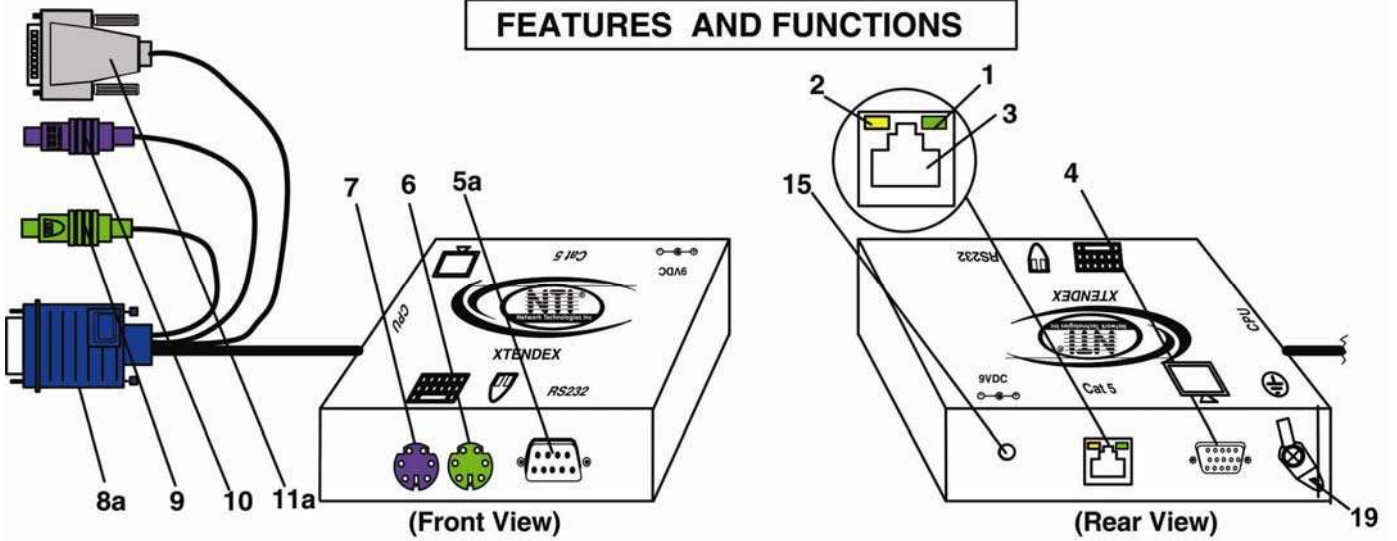

ST-C5KMRS-600 Local Unit

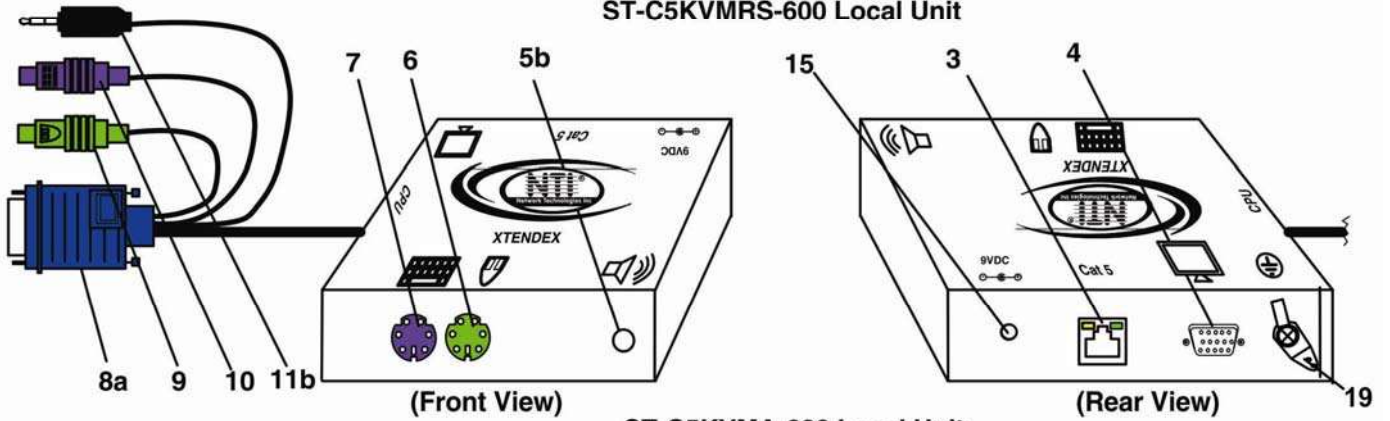

ST-C5KVMA-600 Local Unit

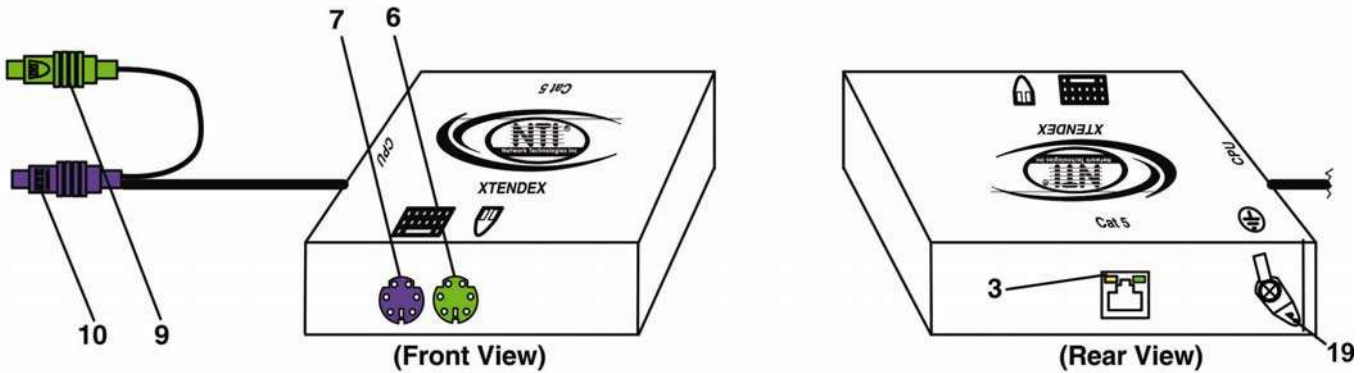

ST-C5KM-600 Local Unit

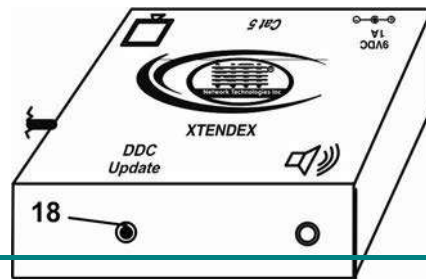

ST-C5VA-600 Local Unit (Front View)

FEATURES AND FUNCTIONS

1. Green LED- power indicator- illuminates when power has been supplied to the unit
2. Yellow LED- traffic indicator- illuminates when there is communication between the local and remote units.
3. Cat 5- RJ45 female- for connecting the CAT 5 cable
4. Video Connector- 15HD female- for connecting the local user's VGA monitor
- 5a. RS232 Connector- 9D male- for connecting the local user's touchscreen monitor (models with RS232 support only)
- 5b. Audio Jack- 3.5mm stereo audio jack- for connecting to local speakers (models with audio support only)
6. Mouse Connector- green female 6 miniDIN- for connecting the local user's mouse
7. Keyboard Connector- purple female 6 miniDIN- for connecting the local user's keyboard
8. Video Connector- blue 15HD male- for connecting to the video port on the CPU or KVM switch
9. Mouse Connector- green male 6 miniDIN- for connecting to the mouse port on the CPU or KVM switch
10. Keyboard Connector- purple male 6 miniDIN- for connecting to the keyboard port on the CPU or KVM switch
- 11a. RS232 Connector- light gray 9D female- for connecting to the RS232 port on the CPU or KVM switch (models with RS232 support only)
- 11b. Audio Plug- 3.5mm stereo audio plug- for connecting to CPU audio line out (models with audio support only)
12. Keyboard Connector- purple female 6 miniDIN- for connecting the remote user's keyboard
13. Mouse Connector- green female 6 miniDIN- for connecting the remote user's mouse
- 14a. RS232 Connector- 9D male- for connecting the remote user's touchscreen monitor (models with RS232 support only)
- 14b. Audio Jack- 3.5mm stereo audio jack- for connecting to remote speakers (models with audio support only)
15. 9VDC- 1.0A- connection jack for the AC adapter
16. Video Connector- 15HD female- for connecting the remote user's monitor
17. Buttons- for manually adjusting video quality (models ST-C5V-600 and ST-C5KVMRS-600-SCI only)
18. DDC Update- Button used to send updated EDID to the graphics card in the CPU (supported models only)
19. Ground Lug- for optional external ground connection

Note: The 15HD female port on the ST-2C5V(A)-L-600 is used for EDID capture only (see page 19).

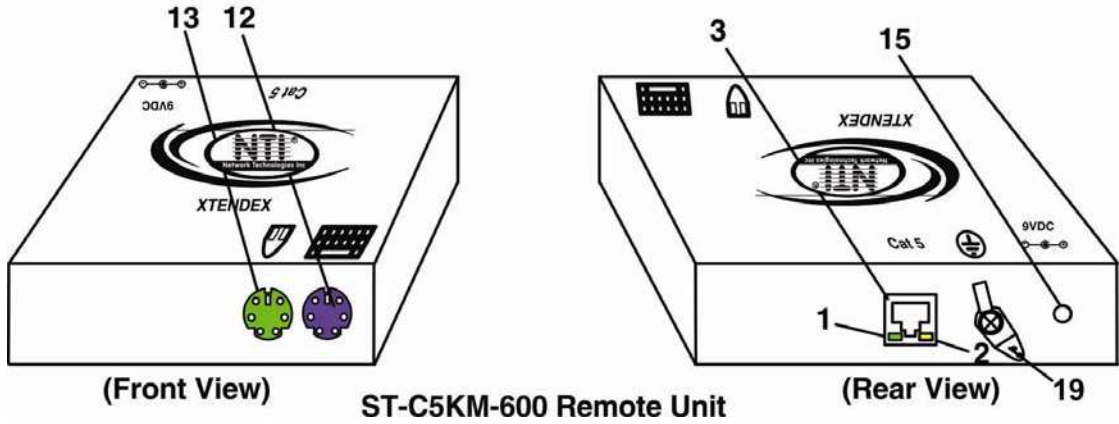
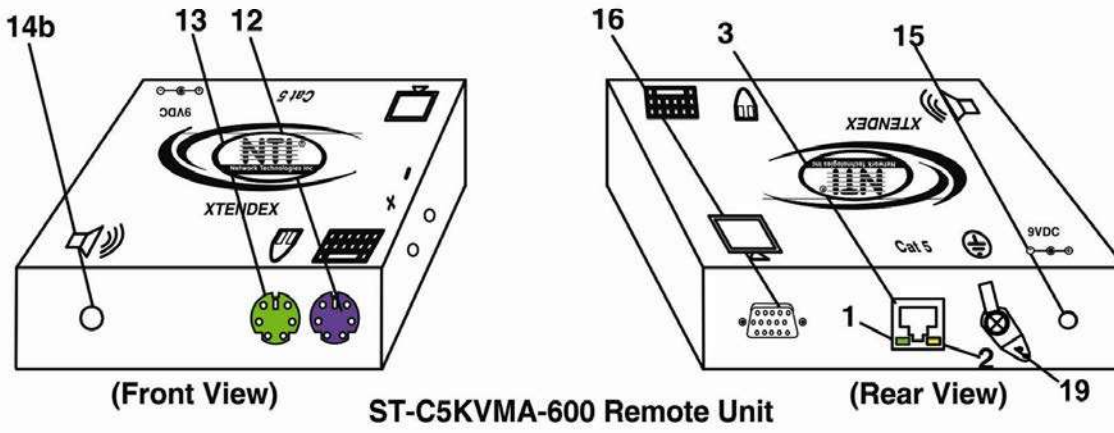
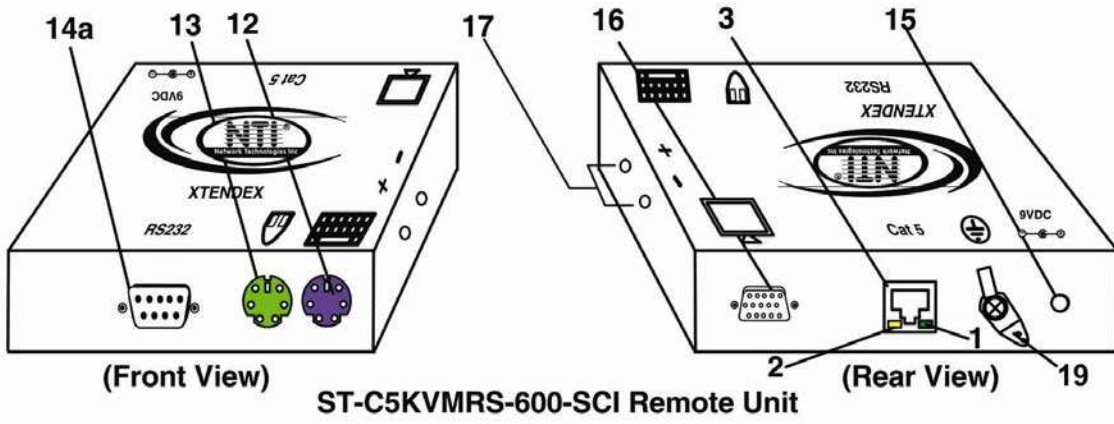
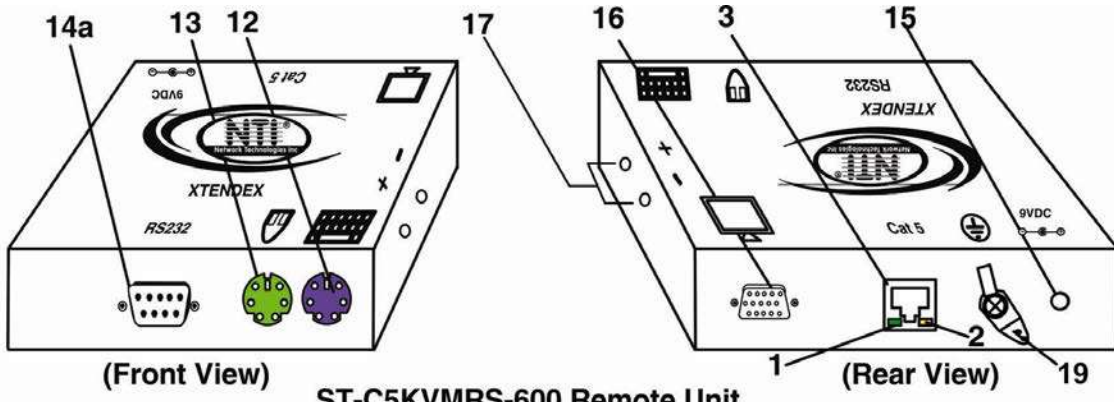

LIMITATIONS

- Hot-plugging of devices is supported provided devices were originally connected at power-up.
- In order for two users to share a PS/2 CPU, the user in control must pause for at least 3 seconds before another user can take control. After the 3 second pause, either user can take control of the CPU.

For models with RS232 support:

- The RS232 ports on the Local and Remote Units will support serial devices other than touchscreen monitors as follows:
 - 2 simple devices (i.e. mice) connected to each unit, or
 - 1 complex device (i.e. serial modem, RS232 command port on an NTI switch) connected to either the Remote or Local Unit.
- In order for two users to share a PS/2 CPU, the user in control must pause for at least 3 seconds before another user can take control. After the 3 second pause, either user can take control of the CPU.
- The RS232 port supports all baud rates up to 56K bits per second and the attached CPU must be configured accordingly.

For models with audio support:

- The audio input of the XTENDEX with audio support is compatible with the following standard CPU audio outputs:
 - Line out - typically lime green in color
 - Speaker out- typically orange in color
 - Headphone out- typically located on the CD-ROM
- The audio output of the XTENDEX with audio support is compatible with self-powered stereo speakers.

PREPARATION FOR INSTALLATION

- Locations should be chosen for the monitors, mice, and keyboards that also have space to connect the Remote and Local Units within the distance provided by the cables. If extension cables are needed, contact NTI for the cables required.
- The CATX cables must be run to the locations where the Remote and Local Units will be connected. Be careful to route the cables away from any sources of magnetic fields or electrical interference that might reduce the quality of the video signal (i.e. AC motors, welding equipment, etc.).
- All cables should be installed in such a way that they do not cause stress on their connections to the equipment. Extended lengths of cable hanging from a connection may interfere with the quality of that connection. Secure cables as needed to minimize this.
- Properly shut down and disconnect the power from the CPU and monitors to be separated. If other equipment is involved whose connections are being interrupted, be sure to refer to the instruction manuals for that equipment for proper disconnection and re-connection procedures before proceeding.
- Local and Remote Units should be grounded through either a display or source that uses a 3-prong power cord. If only one unit is grounded, shielded CAT5 cable should be used.

Note: CATX connection cable used between NTI XTENDEX Series Local and Remote or any XTENDEX Series products should not be run underground, outdoors or between buildings.

WARNING: Outdoor or underground runs of CATX cable could be dangerous and will void the warranty.

External Ground

This product is equipped with grounding hardware to prevent interference from sources of electrical noise that could interfere with the normal operation of the XTENDEX or damage it. Use either the crimp-on lug or solder terminal to secure a properly grounded wire (connected to earth ground) to the XTENDEX.

Failure to make this connection may result in poor video quality at the connected monitor(s).

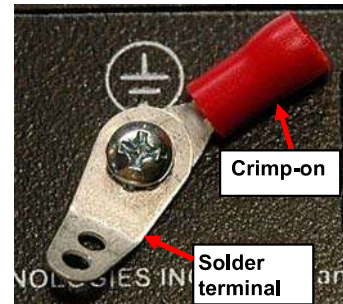

INSTALLATION

Installing The Local Unit (models with VGA video connectors)

1. Plug the cables of the Local Unit into the back of the CPU. (See Figure 1.)
 - a) Connect the blue 15HD cable end to the VGA port on the back of the CPU.
 - b) Connect the purple 6 pin miniDIN cable end with the keyboard symbol on it to the keyboard port on the back of the CPU. (KVM models only)
 - c) Connect the green 6 pin miniDIN cable end with the mouse symbol on it to the mouse port on the back of the CPU. (KVM models only)

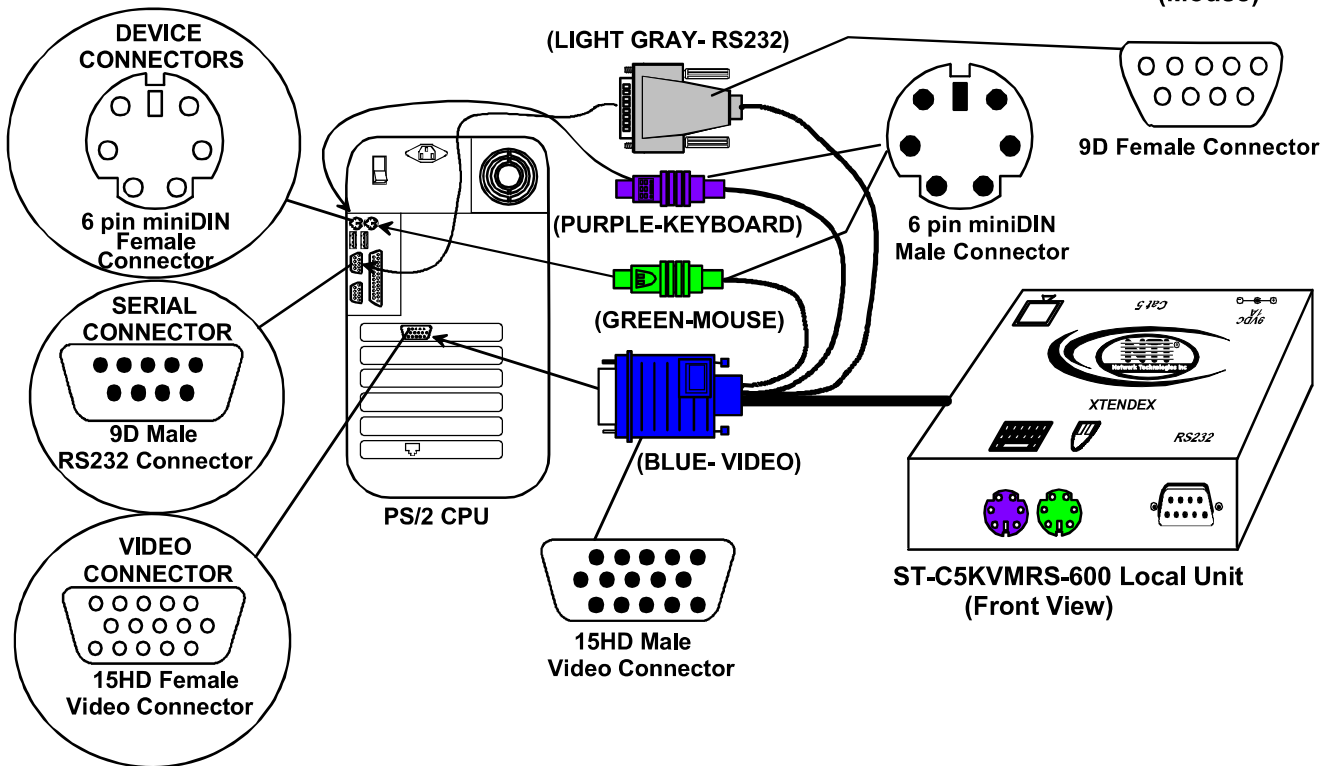
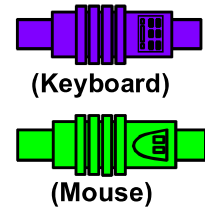

Figure 1- Connect the Local Unit with VGA video and RS232 support to the CPU

- d) If the Local Unit has RS232 support, connect the light gray 9D cable end to the RS232 port on the back of the CPU.
- e) If the Local Unit has Audio support, connect the black 3.5mm stereo plug into the "line out", "spkr", or "headphones" jack on the back of the CPU. (See Figure 2)

Notes:

If all 3 jacks are available, use the jack marked "line out".

The "line out" jack is typically lime green and may be marked with this symbol



The "spkr" jack is typically orange, and may be marked with this symbol



The "headphones" jack may be marked with this symbol



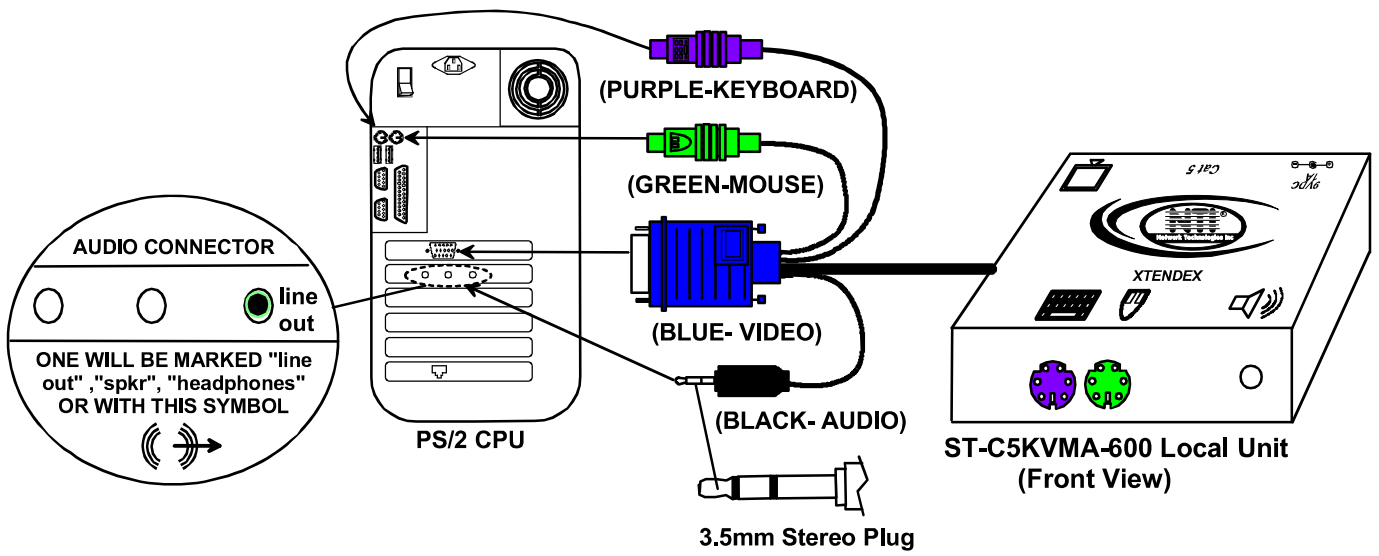

Figure 2- Connect the Local Unit with Audio support to the CPU

2. Make connections for a local user (see Figure 3)
 - a) Connect the cable from the local user's VGA monitor to the female 15HD port on the Local Unit.
 - b) Connect the local user's keyboard to the purple 6 pin miniDIN female port on the Local Unit.
 - c) Connect the local user's mouse to the green 6 pin miniDIN female port on the Local Unit.

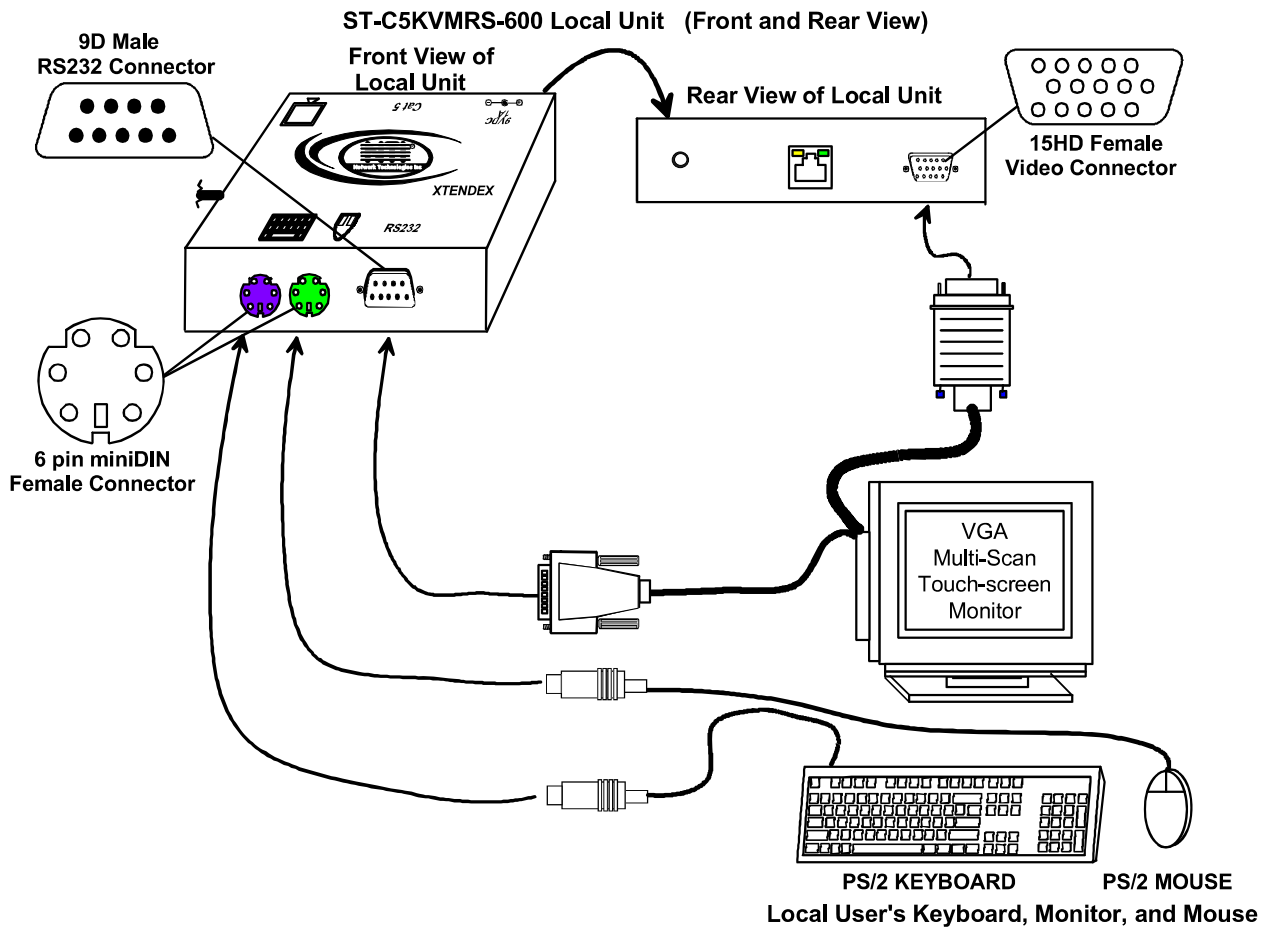

Figure 3- Connect the local user to the XTENDEX Local Unit

- d) If the Local Unit has RS232 support, connect the local user's RS232 cable from a touch screen monitor to the 9D male port on the Local Unit.
- e) If the Local Unit has audio support, connect the cable from the local speakers to the 3.5mm stereo audio jack on the Local Unit. (See Figure 4)

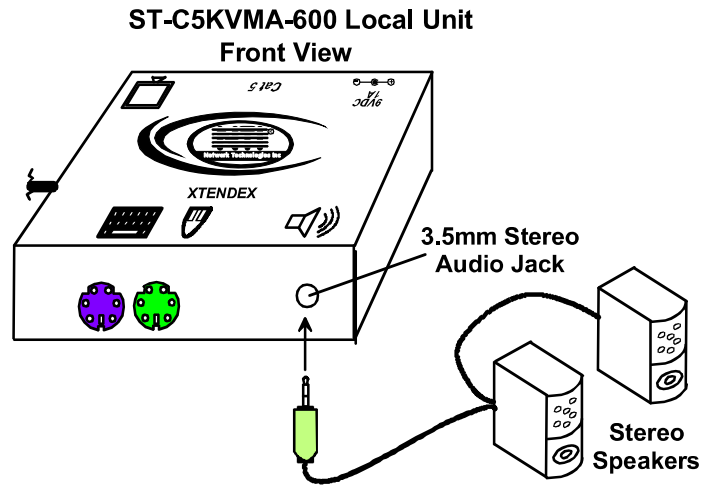

Figure 4- Connect stereo speakers to XTENDEX Local Unit with audio support

Installing the Local Unit (models with only KM connectors)

1. Plug the cables of the Local Unit into the back of the CPU. (See Figure 5)
 - a) Connect the green 6 pin miniDIN cable end with the mouse symbol on it to the mouse port on the back of the CPU.
 - b) Connect the purple 6 pin miniDIN cable end with the keyboard symbol on it to the keyboard port on the back of the CPU.

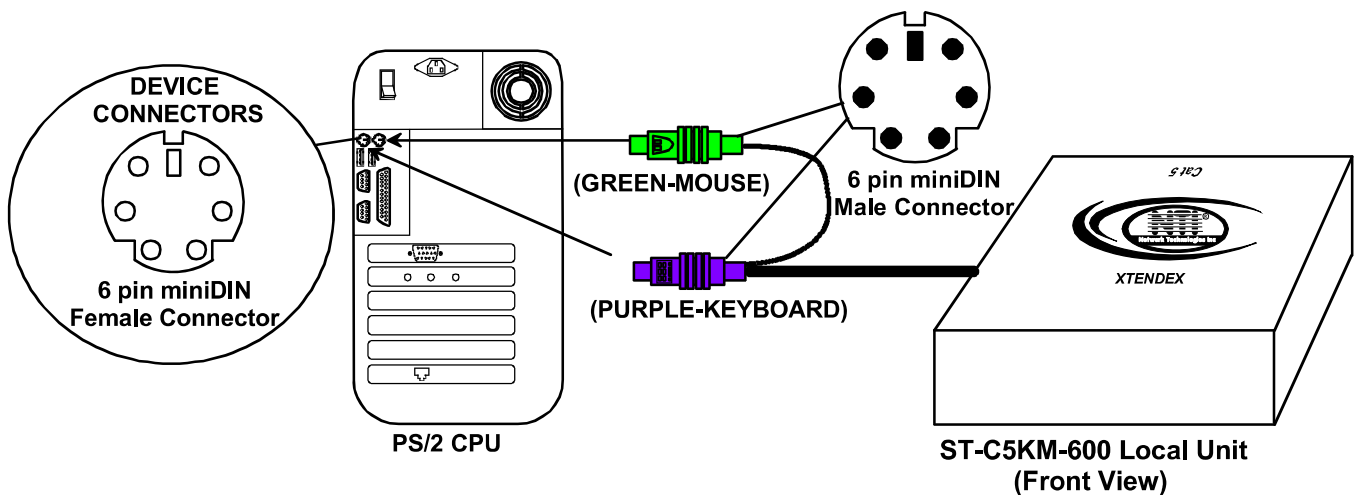

Figure 5- Connect Local Unit with only keyboard and mouse support

Connect The CATx Cable

Connect the CATx cable to the “Cat 5” port on the Local Unit. (See Figure 6.) When properly inserted the cable end should snap into place.

Note: If an RJ45 wall outlet is being used, connect the other end of the extension cable to the RJ45 wall outlet.



WARNING: Never connect the XTENDEX to an Ethernet card, Ethernet router, hub or switch or other Ethernet RJ45 connector of an Ethernet device. Damage to devices connected to the Ethernet may result.

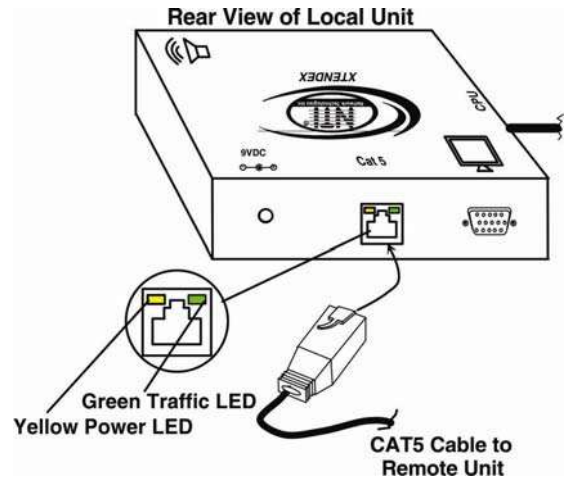

Figure 6- Connect CATx cable to Local Unit

WARNING: The CATx connection cable used between NTI XTENDEX Series Local and Remote or any XTENDEX Series products must be wired straight through (pin 1 to pin 1, pin 2 to pin 2, etc.) The use of a CROSSOVER CABLE will damage the extender and void your warranty.

Installing The Remote Unit (models with VGA video connectors)

1. Position the Remote Unit such that the CATx cable, the monitor cable, device cables, and the AC adapter power connector can each reach the Remote Unit without putting strain on the cables.
2. Connect the monitor cable to the female 15HD video connector on the Remote Unit.
3. Connect the device(s) to the Remote Unit (see Figure 7)(KVM models only).
 - a) Connect the keyboard to the purple female 6 pin miniDIN connector on the Remote Unit.
 - b) Connect the mouse to the green female 6 pin miniDIN connector on the Remote Unit.
4. If the Remote Unit has RS232 support, connect the remote user's RS232 cable from a touch screen monitor to the 9D male port on the Remote Unit.
5. If the Remote Unit has audio support, connect the cable from the remote speakers to the 3.5mm stereo audio jack on the Remote Unit. (See Figure 7)

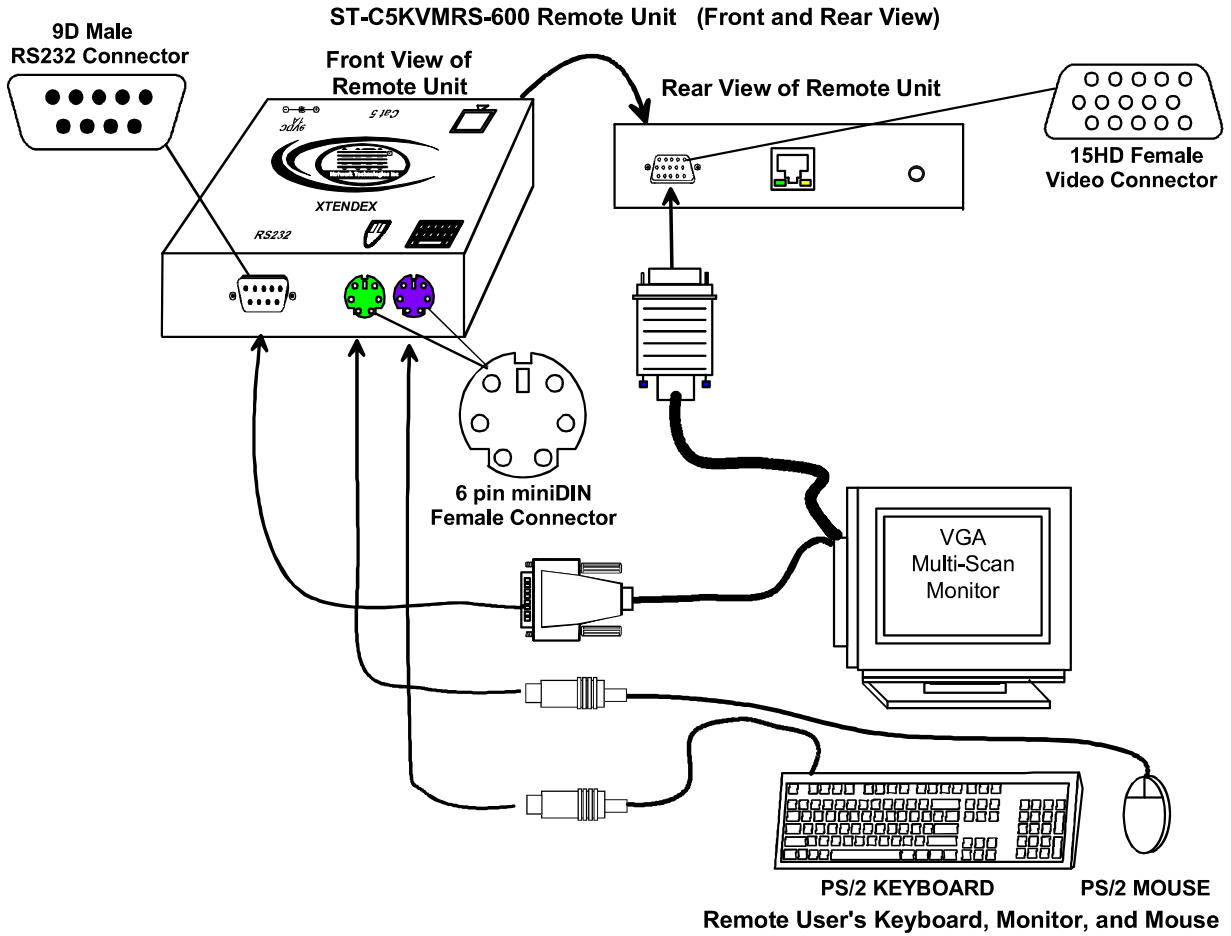

Figure 7- Connect the Extended Components to the Remote Unit

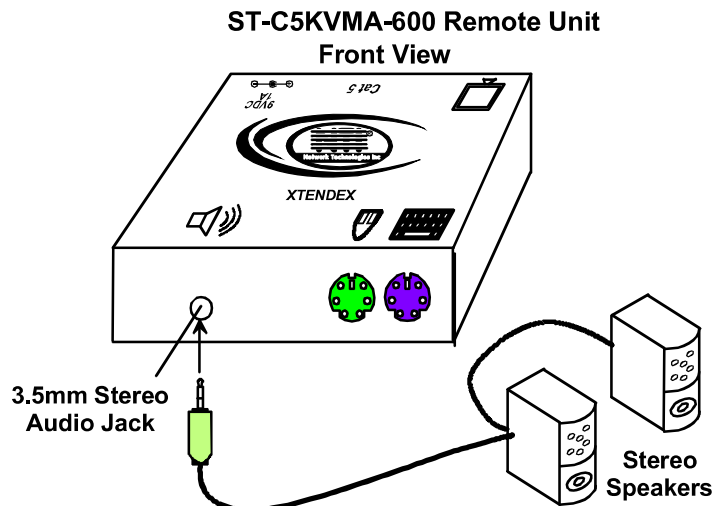

Figure 8- Connect speakers to the Remote Unit

Installing The Remote Unit (models with only KM connectors)

1. Position the Remote Unit such that the CATx cable, the keyboard cable, mouse cable and power supply cable can each reach the Remote Unit without putting strain on the cables.
2. Connect the keyboard to the purple female 6 pin miniDIN connector on the Remote Unit.
3. Connect the mouse to the green female 6 pin miniDIN connector on the Remote Unit.

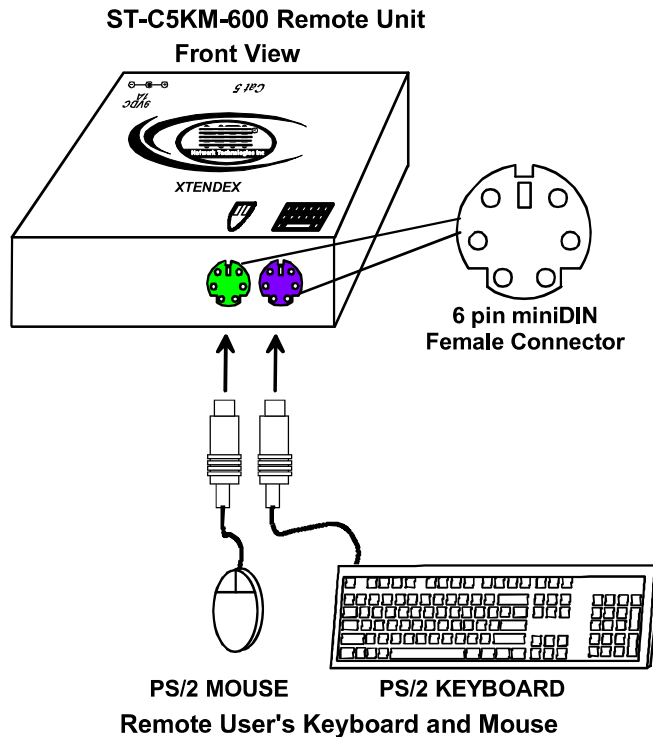

Figure 9- Connect keyboard and mouse to Remote Unit

Connect the CATx cable

Models With One Remote

Make sure the CATx cable has been installed in accordance with the "Preparation for Installation" instructions on page 3. Connect the CATx cable to the "Cat 5" port on the Remote Unit. (See Figure 10.) When properly inserted the CATx cable end should snap into place.

Note: If an RJ45 wall outlet is being used, connect the other end of the extension cable to the RJ45 wall outlet.



WARNING: Never connect the XTENDEX to an Ethernet card, Ethernet router, hub or switch or other Ethernet RJ45 connector of an Ethernet device. Damage to devices connected to the Ethernet may result.

WARNING: The CATx connection cable used between NTI XTENDEX Series Local and Remote or any XTENDEX Series products must be wired straight through (pin 1 to pin 1, pin 2 to pin 2, etc.) The use of a Crossover Cable will damage the extender and void your warranty.

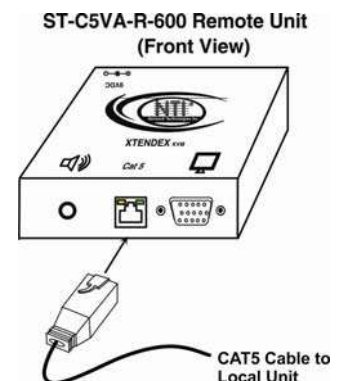

Figure 10- Connect the CATx cable to the Remote Unit

Models With Two Remotes

Connect the CATx cable from each Remote Unit being used to the “CAT5 Remote 1” and “CAT5 Remote 2” ports on the rear of the Local Unit (see Figure 11). When properly inserted the cable end should snap into place.

Make the remaining connections to the Remote Units as described beginning on page 11.



WARNING: Never connect the XTENDEX to an Ethernet card, Ethernet router, hub or switch or other Ethernet RJ45 connector of an Ethernet device. Damage to devices connected to the Ethernet may result.

WARNING: The CATx connection cable used between NTI XTENDEX Series Local and Remote or any XTENDEX Series products must be wired straight through (pin 1 to pin 1, pin 2 to pin 2, etc.) The use of a Crossover Cable will damage the extender and void your warranty.

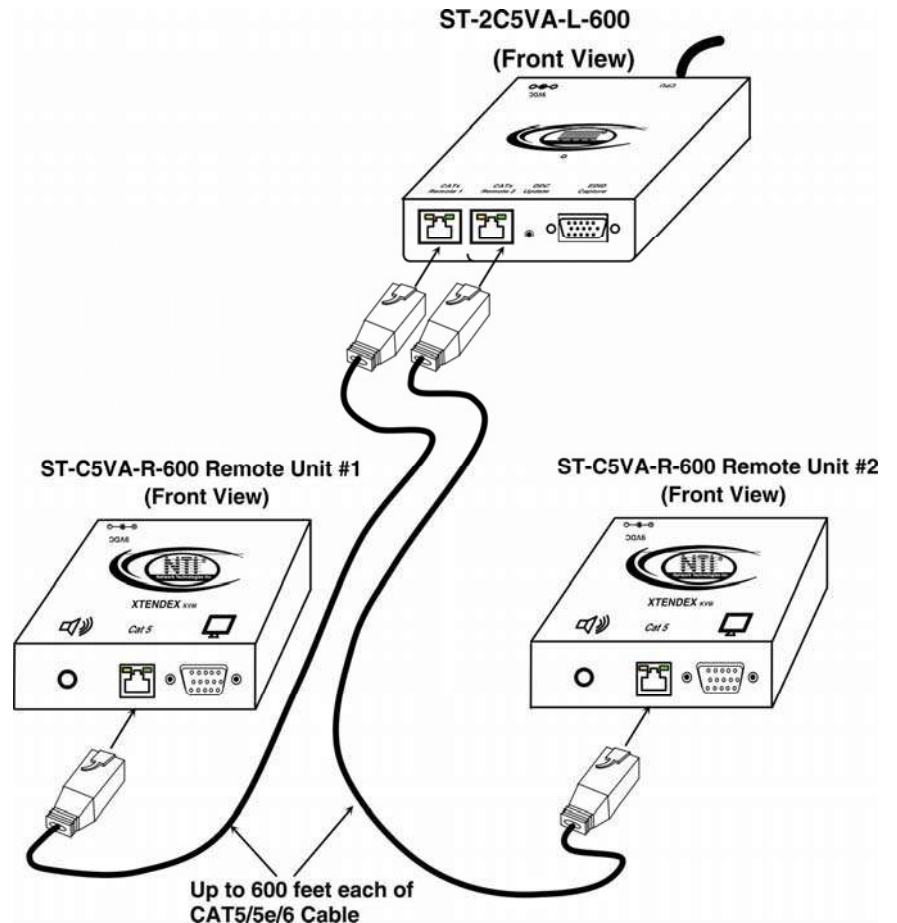

Figure 11- Connect CATx cables between Local and Remote Units

Plug-in and Boot Up

1. Plug the power cord from the monitor into the power outlet.
2. Connect each AC adapter power connector to the 9VDC ports on the Remote and Local Units. Plug each AC adapter into a power outlet. The green LED on the RJ45 connector of both the Remote and Local Units should illuminate, indicating that a proper power connection has been made to them. (See Figure 12.)

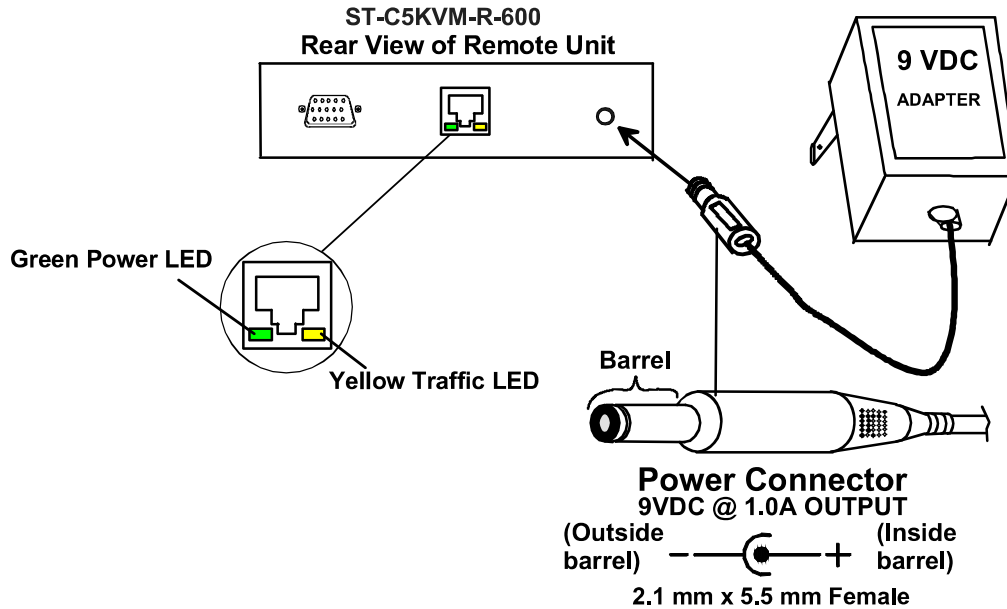

Figure 12- Connect the AC adapter to the Remote Unit

3. Turn ON the CPU and Monitor. They should each react as if they were directly connected to each other.

Note: The Traffic LED on each RJ45 connector will illuminate anytime data traffic is passing between the Local and Remote Units, indicating proper CAT5 cable connection and communication. (See Figure 12)

VIDEO QUALITY

Automatic Video Quality Adjustment (see chart on page 1)

Video quality adjustment is done automatically to assure the image is as clear as possible.

Note: When the cable is longer than 300 feet some colored lines can be seen at the black-to-white transitions. This is a normal behavior and is caused by the different twisting rates of each pair of wires in the CATx cable.

Manual Video Quality Adjustment (see chart on page 1)

It is possible that on initial startup the image on the monitor will not be as crisp as the image normally is. This is due to the frequency characteristics of the CATx cable. It may be necessary to press the "+" or "-" buttons (see Figure 13) until the image is crisp and clear. Press the "+" button if the image is not crisp and clear enough. Press the "-" button if the image has been over-corrected (such that horizontal lines appear to trail or shadow at the edge of an open window). A momentary press of either button will make a minor change in the image. If either button is pressed and held, the changes made will be gradual and continuous. Ultimately, the image quality should improve to a satisfactory level. Once the adjustment is made, it should not be necessary to change it again, as the new settings are stored in memory and become the default settings with each startup.

Note: When the cable is longer than 300 feet some colored lines can be seen at the black-to-white transitions. This is a normal behavior and is caused by the different twisting rates of each pair of wires in the CATx cable.

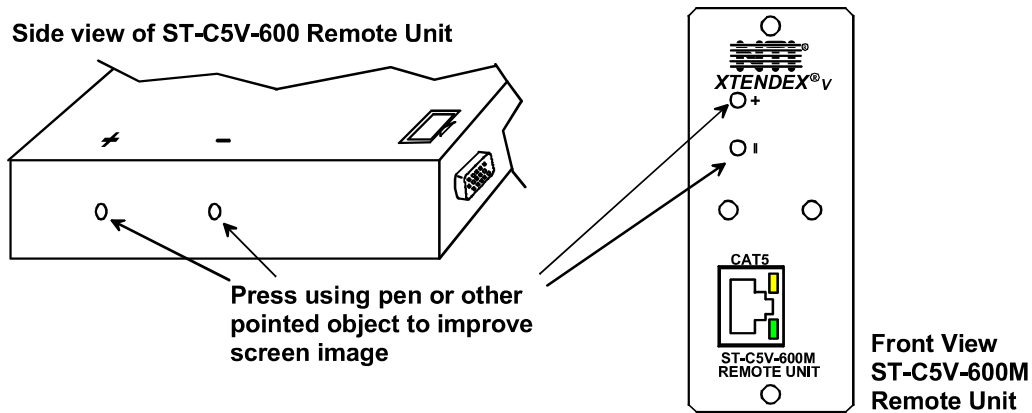

Figure 13- Buttons for video quality adjustment

If the image still lacks definition, configuration adjustments may need to be made to the attached video display equipment. This is a problem most often seen in LCD displays. Check the manual for the equipment having the poor display and look for an "auto-adjust" or "auto-configure" feature. Once this is done, you may need to repeat the Video Quality Adjustment procedure described above to achieve the best image.

Command Mode

Depending upon your unit's date of manufacture, models ST-C5KVM-600, ST-C5KVMA-600 and ST-C5KVMRS-600 may be enabled with a Command Mode feature to update DDC information between the monitor(s) and CPU.

Video quality adjustment is automatic at power ON.

DDC information allows the CPU to detect the video capability of your monitor by transferring EDID data from your monitor to the CPU. DDC information can only be updated from the keyboard at the Remote Unit.

To determine if your extender has this feature, try entering Command Mode (below) from the keyboard attached to the Remote Unit. If Command Mode is present, the three keyboard LEDs (NumLock, CapsLock, and ScrollLock) will blink at the same time to indicate entrance into Command Mode. If the feature is not present, then the section "Automatic EDID Updates" under "Other DDC Support" (page 18) applies to your KVM extender.

Enter Command Mode

The user can enter Command Mode from the keyboard at the Remote Unit using any of three different methods;

Method 1

1. Press and hold the left <Shift> key
2. Press the right <Shift> key
3. Release both keys

Method 2

Press and release the <Scroll Lock> key twice fast (press twice within 1 second)

Method 3

Press and release the left <Shift> key twice fast, then press and release the <Esc> key once, all within 2 seconds

The three keyboard LEDs (NumLock, CapsLock, and ScrollLock) will blink at the same time to indicate entrance into Command Mode.

Update DDC at Remote

To update DDC information based on the monitor connected to the Remote Unit, press <D> to enter Remote DDC information. The CapsLock LED will illuminate solid, the NumLock and ScrollLock LEDs will be OFF. Press the <Left Arrow> or <Right Arrow> key to cause DDC information to be updated. When the update is complete (less than one second), the unit will return to Command Mode (the three keyboard LEDs will blink at the same time).

Update DDC at Local

To update DDC information based on the monitor connected to the Local Unit, press <C> to enter Local DDC information. The CapsLock LED will illuminate solid, the NumLock and ScrollLock LEDs will be OFF. Press the <Left Arrow> or <Right Arrow> key to cause DDC information to be updated. When the update is complete (approximately seven seconds), the unit will return to Command Mode (the three keyboard LEDs will blink at the same time).

Note: It is recommended that the monitors connected to the Remote and Local units be of the same make and model.

Mix DDC

To update DDC information based on resolution characteristics common to the monitors connected to the Local and Remote units, press <N> to enter DDC information from both. The CapsLock LED will illuminate solid, the NumLock and ScrollLock LEDs will be OFF. Press the <Left Arrow> or <Right Arrow> key to cause DDC information to be updated. When the update is complete (approximately seven seconds), the unit will return to Command Mode (the three keyboard LEDs will blink at the same time).

Keyboard LED Indications

Adjustment Mode	NUM LOCK	CAPS LOCK	SCROLL LOCK
Command Mode	Blink	Blink	Blink
DDC Updating	OFF	Solid	OFF

Reset Defaults

Press the <A> key (while in Command Mode) to reset the video quality settings to default. Once settings have been reset, the user will automatically return to Command Mode.

Exit Command Mode

Press the <Esc> key to exit Command Mode and return to normal operation. All keyboard LEDs will return to current keyboard LED state.

Note: Command Mode will time out and return to normal operation on its own after 7 seconds.

FYI: Video quality will be limited by several factors. Some factors include the quality and type of CAT5 cable being used, the length of cable run, the quality of the monitor, the resolution setting of the monitor, and the quality of the video card used in the video source. If the desired level of image clarity cannot be achieved by making the adjustments described in this section, consider the following possible adjustments that can be made:

- Improve the quality of cable used -CAT5,5e,or 6 (CAT5e unshielded (UTP) cable will provide the best performance)
- Use unshielded cable (UTP) instead of shielded cable (STP)
- Shorten the length of the cable between the remote and local
- Reduce the resolution setting on the monitor used
- Use a higher quality video card in the video source

Other DDC Support

Automatic EDID Updates

Applicable to models without keyboard and mouse support and rackmount models (ST-C5xxxx-600M).

The 15HD connector on many models provides local video as well as DDC support. The EDID data is updated automatically at initial power-ON or whenever a different monitor is connected to the Local Unit. **DDC is only updated from the monitor connected to the Local Unit.** For that reason, it is recommended that the monitor connected to the Remote and Local Units be the same model. The Local Unit and the monitor must both be powered-ON prior to the CPU in order to update the EDID data.

Note: The ST-C5xxx-L-600M Local Unit will not store the EDID data. A monitor must be connected to the Local Unit each time the CPU is power cycled in order for EDID data to remain current.

Note: When an ST-C5KVM(xx)-R-600 Remote Unit is used with an ST-C5KVM(xx)-L-600M (Rackmount Local Unit), Automatic EDID Update will work as described above. DDC Update via Command Mode (as described on the previous page) will not be supported at the Remote Unit.

Manual EDID Capture

Applicable to ST-2C5xxx-L-600 models only.

The 15HD connector on the **ST-2C5V(A)-L-600** provides only support for DDC, no video. The ST-2C5V(A)-L-600 Local Unit includes a button labeled “DDC Update” to be pressed in order to record and save EDID data.

To capture EDID data;

1. Connect a monitor to the 15HD connector on the Local Unit labeled “EDID Capture”.
2. Power ON both the monitor and Local Units.
3. Press the button labeled “DDC Update” with a sharp object.

The capture will start right away and the green LED of the “CAT5 Remote 1” connector will turn OFF while the EDID data is transferred. The green LED will illuminate again once the transfer is complete and the unit is ready for normal use. The ST-2C5V(A)-L-600 Local Unit will save the EDID data and present that information to the CPU any time the CPU is power-cycled.

Note: The 15HD connector on the ST-2C5V(A)-L-600 is only used for capturing EDID data. It is not a video port for viewing local video.

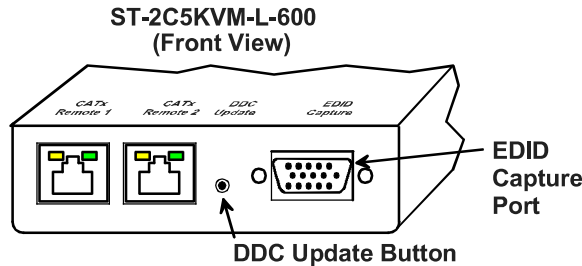

Figure 14- DDC Update Button on Local with Dual Remote Support

When used, the monitors connected to both Remote Units should be the same model. If necessary, the Local Unit can be connected to the monitor at the site of the remote and powered by the power supply at the remote location. Following the process described above, EDID data can be recorded and the Local Unit relocated to the site of the CPU.

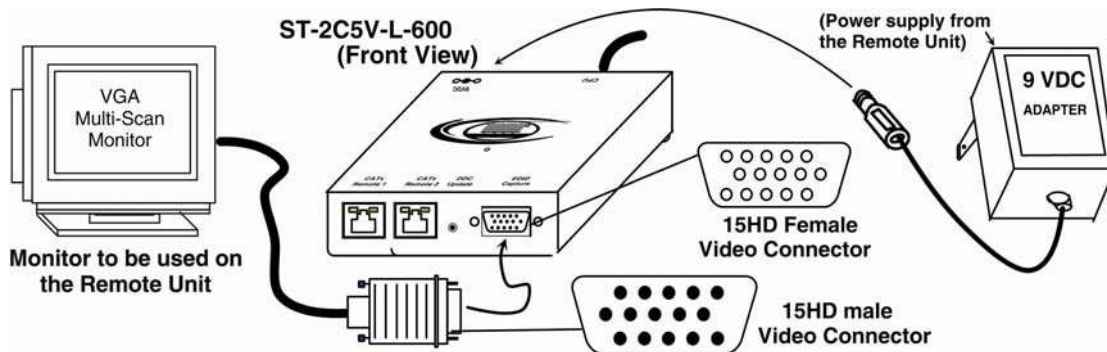
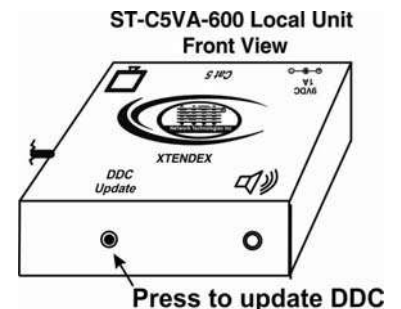

Figure 15- Connect remote monitor for EDID capture

Applicable to ST-C5xxx-L-600 models only.

The 15HD connector on the **ST-C5V, -C5VA and -C5VRS-L-600** supports DDC and video. If your unit includes a “DDC Update” button, it can be pressed in order to retrieve EDID from the Remote and Local monitor and forward it to the CPU. Additionally, the ST-C5Vxx-L-600 Local Unit will save the EDID data and present that information to the CPU any time the CPU is power-cycled. The EDID capture method is the same as described above.



More About DDC

The recording and DDC transfer of EDID data from the monitor(s) enables the CPU to know what resolution settings are compatible with the monitor(s) connected. Once this data is provided to the CPU, your graphics card will either automatically update to the best resolution available (some models of graphic cards, not all), or you will need to choose from the available settings. Bear in mind, the choices of settings compatible with the monitors are not necessarily all going to be usable. If the length of CATx cable in your installation is too long for the selected resolution, the image at the Remote Unit monitor may not be viewable. Be sure to select a resolution setting that your installation will support. For supported combinations, see the chart on page 22.

TECHNICAL SPECIFICATIONS

Models with VGA Video	
Video Compatibility	XGA, VGA
Video Coupling	DC
Video Connectors	HD15 male to CPU HD15 female to monitor
Input / Output Impedance	75 Ohms
Input Horizontal Frequency Range	15kHz to 130 Hz
Input Vertical Frequency Range	30 Hz to 150 Hz
Sync Types Supported	Separate and composite TTL Level and sync on green
Video Maximum I/O Levels	1.45Vp-p
Models with Keyboard/Mouse support	
Keyboard/Mouse Connectors	Female 6 pin miniDIN to Keyboard and Mouse Male 6 pin miniDIN to CPU device ports
Mouse and Keyboard Compatibility	All PS/2 mice and keyboards
Keyboard and Mouse Current Rating	500mA maximum
Models with Audio Support	
Audio Connectors	3.5mm stereo jack to speakers 3.5mm stereo plug to CPU (VGA Video Models)
Signal Type	Line Level, stereo, unbalanced
Audio Frequency Response	20Hz to 20Khz, \pm 1dB
Signal-to-noise ratio	76 dBA
Total Harmonic Distortion and Noise	0.017%
Stereo Crosstalk	-70 dB
Audio Maximum I/O Levels	3.1Vp-p
Output Impedance	Max 2K Ohms, unbalanced
THD+N	0.017%,F=20-20KHz, RL=2K Ohm, Vout=1 Vrms
Models with RS232 Support	
RS232 Connectors	9D male to device 9D female to CPU
RS232 Baud Rate	56K bps maximum (no adjustment for baud rate is needed)
RS232 Compatibility	RXD, TXD, RTS, DTR, CTS, DSR
General	
Interconnect Cable	CAT5/5e/6 Solid UTP EIA/TIA 568 B wiring w/ male RJ45 connectors
Remote and Local Unit Power	120V or 240V at 50 or 60Hz-9VDC/1.0A via AC Adapters (2)
Dimensions WxDxH (In.) (Local or Remote)	3.5x3.1x1.2

Distances and Resolutions for CAT5/CAT5e and CAT6 Cables Unshielded Twisted Pair (UTP) Resolutions

UTP CABLE	DISTANCE (feet)	RESOLUTION
CAT5/CAT5e	600	1024x768 at 60Hz
CAT5/CAT5e	400	1280x1024 at 60Hz
CAT5/CAT5e	300	1600x1200 at 60Hz
CAT5/CAT5e	100	1920x1440 at 60Hz
CAT6	300	1024x768 at 60Hz
CAT6	200	1280x1024 at 60Hz
CAT6	100	1920x1440 at 60Hz

INTERCONNECTION CABLE WIRING METHOD

The connection cable between the remote and local is terminated with RJ45 connectors and must be wired according to the EIA/TIA 568 B industry standard. Wiring is as per the table and drawing below.

Pin	Wire Color	Pair	Function
1	White/Orange	2	T
2	Orange	2	R
3	White/Green	3	T
4	Blue	1	R
5	White/Blue	1	T
6	Green	3	R
7	White/Brown	4	T
8	Brown	4	R

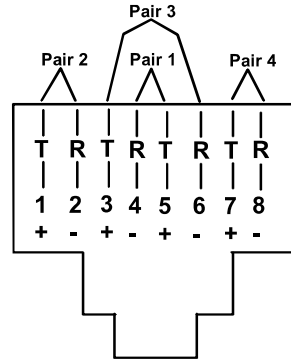

Figure 16- View looking into RJ45 female

TROUBLESHOOTING

Each and every piece of every product produced by Network Technologies Inc is 100% tested to exacting specifications. We make every effort to insure trouble-free installation and operation of our products. If problems are experienced while installing this product, please look over the troubleshooting chart below to see if perhaps we can answer any questions that arise. If the answer is not found in the chart, a solution may be found in the knowledgebase on our website at <http://information.networktechinc.com/jive/kbindex.jspa> or contact us directly for help at 1-800-742-8324 (800-RGB-TECH) in US & Canada or 1-330-562-7070 worldwide. We will be happy to assist in any way we can.

Problem	Cause	Solution
Remote or Local Unit yellow power LED does not illuminate	<ul style="list-style-type: none"> Power supply is not connected or plugged-in. 	<ul style="list-style-type: none"> Make sure outlet is live and AC adapter is plugged-in. (one for the Remote and one for the Local) Make sure 9VDC jack is fully connected
Computer does not boot with the right resolution	<ul style="list-style-type: none"> The extender is not passing the correct EDID to the monitor 	<ul style="list-style-type: none"> Perform a DDC update (see pages 18-19)
No Video on monitor	<ul style="list-style-type: none"> One or more video cables is loose or disconnected. No power to Remote or Local Units. Video Cable was not attached when CPU was booted. CATx cable is not connected. Local and/or Remote Unit has no earth ground 	<ul style="list-style-type: none"> Check all video cable connections Make sure yellow LEDs are illuminated for local and remote. If not, see solutions for first two problems above. With all the cables properly connected, reboot the CPU. Check cable connections. Make sure they are snapped-in properly and completely and reboot. Ensure Local and Remote Units are grounded either through display or a source that uses a 3-prong power cord.
Video Picture is not sharp or is smeared	<ul style="list-style-type: none"> CATx cable is too long. Video not adjusted 	<ul style="list-style-type: none"> Verify length is within specified limits-600'. Check cable connections and power cycle. If model has manual quality adjustment buttons see page 24 for adjustment instruction.
The picture on the monitor is black and white, rather than color	The video cable was not attached to the CPU when it was booted.	With the cables all properly connected, reboot the CPU.
A constant vertical wobble appears down the screen	CATx cable is too close to a strong power source.	Reroute CATx cable if possible.
Monitor sometimes loses sync, causing it to go blank for a second or two	<ul style="list-style-type: none"> Electrical power system is very noisy, particularly the ground. The CATx cable is not properly connected. 	<ul style="list-style-type: none"> Make sure the interconnection cable is not near any power lines. Check cable connections. Make sure they are snapped-in properly and completely.
Wrong or missing characters from those typed	The keyboard may be in the wrong mode.	<ul style="list-style-type: none"> Disconnect keyboard at Remote Unit end and reconnect. Reboot the system.
CPU doesn't detect the keyboard and the mouse	<ul style="list-style-type: none"> Keyboard cable or mouse cable are loose or reversed CATx cable is too long 	<ul style="list-style-type: none"> Check cable connections CATx cable can be no more than 600 feet in length
IBM Scroll Point mouse is not recognized by CPU	Only one IBM Scroll Point mouse is connected at either the Local or Remote unit	<ul style="list-style-type: none"> In order for an IBM Scroll Point mouse to be recognized, an IBM Scroll Point mouse must be connected at <u>both</u> the Local and Remote extender units. Otherwise it will be recognized and work only as a Microsoft Intellimouse.
Image is not displayed properly, lacks definition	Signal is being skewed by the CATx cable and not being received correctly by the monitor .	<ul style="list-style-type: none"> Check the user's manual for the monitor, projector, or display equipment for an "automatic adjustment" or "auto-configure". This is most common to LCD type monitors.

Problem	Cause	Solution
Models with RS232 Support		
No RS232 communication	<ul style="list-style-type: none"> One or more RS232 cables is loose or disconnected 	<ul style="list-style-type: none"> Check all RS232 cable connections
Models with Audio Support		
No audio	<ul style="list-style-type: none"> Audio cable is not properly plugged in Speakers are not plugged in CATx cable is not properly connected 	<ul style="list-style-type: none"> Check all cable connections Verify speakers are connected and powered Check CATx cable connections

INDEX

cat5 cable pinout, 22	preparation to install, 7
Command mode, 17	reset defaults, 18
DDC, 17	resolution chart , 21
DDC support, 17	technical specification, 21
installation-desktop, 8	video quality adjustment, 16
limitations, 6	

WARRANTY INFORMATION

The warranty period on this product (parts and labor) is two (2) years from the date of purchase. Please contact Network Technologies Inc at **(800) 742-8324** (800-RGB-TECH) or **(330) 562-7070** or visit our website at <http://www.networktechinc.com> for information regarding repairs and/or returns. A return authorization number is required for all repairs/returns.

Note: CATx connection cable used between NTI XTENDEX Series Local and Remote or any XTENDEX Series products should not be run underground, outdoors or between buildings.

WARNING: Outdoor or underground runs of CATx cable could be dangerous and will void the warranty.

WARNING: The CATx connection cable used between NTI XTENDEX Series Local and Remote or any XTENDEX Series products must be wired straight through (pin 1 to pin 1, pin 2 to pin 2, etc.) The use of a Crossover Cable will damage the extender and void your warranty.