



**Paging Station Microphone**

---

# PGM1

**Paging Station Extension**

---

# PGX1

**Installation Manual  
Installationshandbuch  
Manuel d'installation  
Manual de instalación  
Manual de instalação  
Manuale all'installazione  
Руководство по установке  
施工説明書**

**EN  
DE  
FR  
ES  
PT  
IT  
RU  
JA**

English

Deutsch

Français

Español

Português

Italiano

Русский

日本語

# FCC INFORMATION (U.S.A.)

## 1. IMPORTANT NOTICE: DO NOT MODIFY THIS UNIT!

This product, when installed as indicated in the instructions contained in this manual, meets FCC requirements. Modifications not expressly approved by Yamaha may void your authority, granted by the FCC, to use the product.

**2. IMPORTANT:** When connecting this product to accessories and/or another product use only high quality shielded cables. Cable/s supplied with this product **MUST** be used. Follow all installation instructions. Failure to follow instructions could void your FCC authorization to use this product in the USA.

**3. NOTE:** This product has been tested and found to comply with the requirements listed in FCC Regulations, Part 15 for Class "B" digital devices. Compliance with these requirements provides a reasonable level of assurance that your use of this product in a residential environment will not result in harmful interference with other electronic devices. This equipment generates/uses radio frequencies and, if not installed and used according to the instructions found in the users manual, may cause interference harmful to the operation of other

electronic devices. Compliance with FCC regulations does not guarantee that interference will not occur in all installations. If this product is found to be the source of interference, which can be determined by turning the unit "OFF" and "ON"; please try to eliminate the problem by using one of the following measures:

Relocate either this product or the device that is being affected by the interference.

Utilize power outlets that are on different branch (circuit breaker or fuse) circuits or install AC line filter/s.

In the case of radio or TV interference, relocate/reorient the antenna. If the antenna lead-in is 300 ohm ribbon lead, change the lead-in to co-axial type cable.

If these corrective measures do not produce satisfactory results, please contact the local retailer authorized to distribute this type of product. If you can not locate the appropriate retailer, please contact Yamaha Corporation of America, Electronic Service Division, 6600 Orangethorpe Ave, Buena Park, CA90620

The above statements apply **ONLY** to those products distributed by Yamaha Corporation of America or its subsidiaries.

(class B)

This device complies with Part 15 of the FCC Rules. Operation is subject to the following two conditions: (1) this device may not cause harmful interference, and (2) this device must accept any interference received, including interference that may cause undesired operation.

## CAN ICES-3 (B)/NMB-3(B)

(can\_b\_02)

이 기기는 가정용(B급) 전자파적합기기로서 주로 가정에서 사용하는 것을 목적으로 하며, 모든 지역에서 사용할 수 있습니다.

(class b korea)

# PRECAUTIONS

## PLEASE READ CAREFULLY BEFORE PROCEEDING

Please keep this manual in a safe place for future reference.



### **WARNING**

**Always follow the basic precautions listed below to avoid the possibility of serious injury or even death from electrical shock, short-circuiting, damages, fire or other hazards. These precautions include, but are not limited to, the following:**

#### **Do not open**

- This device contains no user-serviceable parts. Do not open the device or attempt to disassemble the internal parts or modify them in any way. If it should appear to be malfunctioning, discontinue use immediately and have it inspected by qualified Yamaha service personnel.

#### **Water warning**

- Do not expose the device to rain, use it near water or in damp or wet conditions, or place on it any containers (such as vases, bottles or glasses) containing liquids which might spill into any openings. If any liquid such as water seeps into the device, turn off the power of the PoE injector or the PoE network switch immediately and unplug the cable. Then have the device inspected by qualified Yamaha service personnel.
- Never insert or remove an electric plug with wet hands.

#### **Fire warning**

- Do not place any burning items or open flames near the device, since they may cause a fire.

#### **If you notice any abnormality**

- If any of the following problems occur, immediately turn off the PoE injector or the PoE network switch and disconnect the cable.
  - Unusual smells or smoke are emitted.
  - Some object has been dropped into the device.
  - There is a sudden loss of sound during use of the device.
  - Cracks or other visible damage appear on the device.
 Then have the device inspected or repaired by qualified Yamaha service personnel.



### **CAUTION**

**Always follow the basic precautions listed below to avoid the possibility of physical injury to you or others, or damage to the device or other property. These precautions include, but are not limited to, the following:**

#### **Location**

- Do not place the device in an unstable position where it might accidentally fall over and cause injuries.
- Do not place the device in a location where it may come into contact with corrosive gases or salt air. Doing so may result in malfunction.
- Before moving the device, remove all connected cables.

## Handling caution

---

- Do not insert your fingers or hands in any gaps or openings on the device (panel, etc.).
- Avoid inserting or dropping foreign objects (paper, plastic, metal, etc.) into any gaps or openings on the device (panel, etc.) If this happens, immediately turn off the power of the PoE injector or the PoE network switch, unplug the cable, and have the device inspected by qualified Yamaha service personnel.
- Do not rest your weight on the device or place heavy objects on it. Avoid applying excessive force to the buttons, switches or connectors to prevent injuries.
- Avoid pulling the connected cables to prevent injuries or damage to the device by causing it to fall.

Yamaha cannot be held responsible for damage caused by improper use or modifications to the device.

## NOTICE

To avoid the possibility of malfunction/ damage to the product, damage to data, or damage to other property, follow the notices below.

### Handling and maintenance

- Do not use the device in the vicinity of a TV, radio, AV equipment, mobile phone, or other electric devices. Otherwise, the device, TV, or radio may generate noise.
- Do not expose the device to excessive dust or vibration, or extreme cold or heat (such as in direct sunlight, near a heater, or in a car during the day), in order to prevent the possibility of panel disfiguration, unstable operation, or damage to the internal components.
- Do not place vinyl, plastic or rubber objects on the device, since this might discolor the panel.
- When cleaning the device, use a dry and soft cloth. Do not use paint thinners, solvents, cleaning fluids, or chemical-impregnated wiping cloths.
- Condensation can occur in the device due to rapid, drastic changes in ambient temperature—when the device is moved from one location to another, or air conditioning is turned on or off, for example. Using the device while condensation is present can cause damage. If there is reason to believe that condensation might have occurred, leave the device for several hours without turning on the power until the condensation has completely dried out.

## Information

### About functions/data bundled with the device

- Use STP (Shielded Twisted Pair) cable to prevent electromagnetic interference.
- This product uses Dante Ultimo. Refer to the Audinate website (English) for details on the open-source licenses for the particular software.  
<https://www.audinate.com/software-licensing>

### Regarding disposal

- This product contains recyclable components. When disposing of this product, please contact the appropriate local authorities.

### About this manual

- The illustrations as shown in this manual are for instructional purposes only.
- The company names and product names in this manual are the trademarks or registered trademarks of their respective companies.
- Software may be revised and updated without prior notice.

The model number, serial number, power requirements, etc., may be found on or near the name plate, which is at the bottom of the unit. You should note this serial number in the space provided below and retain this manual as a permanent record of your purchase to aid identification in the event of theft.

**Model No.**

---

**Serial No.**

---

(bottom\_en\_01)

# Contents

<b>PRECAUTIONS</b> .....	<b>3</b>
<b>Introduction</b> .....	<b>7</b>
<b>Features</b> .....	<b>7</b>
<b>What you'll need to provide</b> .....	<b>7</b>
<b>Controls and Connectors (PGM1)</b> .....	<b>8</b>
Top Panel .....	8
Rear Panel.....	9
Bottom Panel.....	11
<b>Controls and Connectors (PGX1)</b> .....	<b>12</b>
Top Panel .....	12
Bottom Panel.....	12
<b>Initializing the PGM1</b> .....	<b>13</b>
<b>Connecting the PGM1 to an MTX/MRX system</b> .....	<b>14</b>
About the priority mic .....	14
<b>Connecting a PGX1</b> .....	<b>16</b>
<b>Indicator list</b> .....	<b>17</b>
Status indicator .....	17
Indicator operation diagram .....	17
<b>Alert list</b> .....	<b>18</b>
<b>Specifications</b> .....	<b>133</b>
<b>Dimensions</b> .....	<b>135</b>

## Included items

- PGM1/PGX1 Installation Manual (this document)
- PGM1/PGX1 Zone label (1 sheet)
- PGM1: Gooseneck mic
- PGX1: Connecting bracket, dedicated screws (8 pcs.), connection cable

## Firmware update

MTX-MRX Editor is used to update the firmware of the PGM1/PGX1 and to check the version. For details on how to perform these operations, refer to "MTX-MRX Editor User Guide."

The latest firmware can be downloaded from the download page of the following website.

<http://www.yamahaproaudio.com/>

# Introduction

Thank you for purchasing the Yamaha PGM1 paging station microphone or the PGX1 paging station extension. These products are a paging station microphone and an extension unit used in an installed system for on-premises broadcast. This installation manual explains installation methods for the installing technician or the designer. Be sure to read this installation manual before installing the units. After reading this manual, keep it for future reference.

## Features

The PGM1/PGX1 are paging stations that can be used with the MTX5-D or MRX7-D. They provide the following features.

- Paging stations can be networked via a Dante network and PoE (Power over Ethernet).
- Chimes and messages can be played back using an SD card player.
- Two PGX1 units can be added for each PGM1 unit, allowing you to specify broadcast regions in detail and to select from numerous messages.
- You can use MTX-MRX Editor to install up to four PGM1 units in one MTX/MRX system. One of these PGM1 units can be specified as the priority mic.

## What you'll need to provide

- **PoE injector or PoE network switch that supports IEEE802.3af**  
This is used between the MTX/MRX system and the PGM1 in order to supply power to the PGM1 and the PGX1.  
PoE injector units and PoE network switches are collectively referred to as “PSE (Power Sourcing Equipment).”
- **Ethernet cables (CAT5e or better)**  
These are used between the MTX/MRX system and the PSE, and between the PSE and the PGM1.
- **Phillips screwdriver**  
This is used when connecting a PGX1.

# Controls and Connectors (PGM1)

## Top Panel

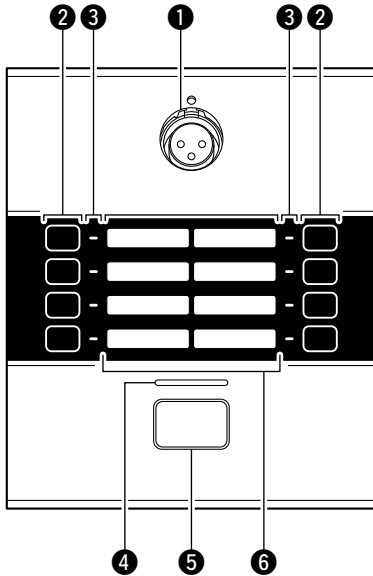

### 1 Mic input jack

Connect the included gooseneck mic (condenser mic) here.

To connect the mic, plug it straight into the mic input jack.

To remove the mic, pull the mic upward while pressing an ejector tool (a thin metal rod of about  $\varnothing 2$ , or a very thin screwdriver) into the hole located above the mic input jack. When doing so, firmly grasp the base of the mic's connector.

#### NOTICE

- Because the phantom power supply is always on, you should connect the mic when power is not being supplied to the unit.
- Do not connect any mic or device other than the included mic.

### 2 Zone/message select buttons

These buttons select the zone(s) to which the mic will broadcast, or select messages saved on the SD card. Use MTX-MRX Editor to assign zones or messages to these buttons. More than one broadcast zone can be selected at the same time. Only one message can be selected. For details on how to make settings, refer to "MTX-MRX Editor User Guide."

### 3 Zone/message indicators

These indicators light to indicate the currently selected zone(s) or message.

### 4 Status indicator

This indicator is lit green when broadcast from the mic is possible. During broadcast, the indicator is lit red. For other indications, refer to page 17.

### 5 PTT (Push To Talk) button

Press this button to switch the mic on/off. You can use MTX-MRX Editor to change the operation of this button between latched and unlatched.

### 6 Labels

Labels with the name of each zone can be inserted here. You can create labels using PGM1 Label Creator which is included with MTX-MRX Editor.

## Rear Panel

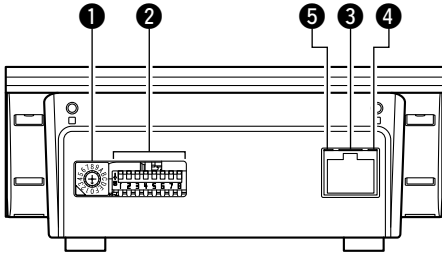

### 1 [UNIT ID] rotary switch

This specifies the ID by which individual PGM1 units are distinguished within the MTX/MRX system's network. In conjunction with device setting DIP switches 1–3 which specify the upper place, this rotary switch specifies the lower place, allowing you to set the UNIT ID in the range of 01 to 7F.

#### NOTE

- A rubber cap is attached here when the unit is shipped from the factory; remove the rubber cap to change the switch setting. To prevent dust from entering, reattach the rubber cap after you have made the setting.
- Do not set the UNIT ID to 00.
- After setting the [UNIT ID] rotary switch, power-off the PoE injector / PoE network switch (PSE) and then power it on again.

### 2 Device setting DIP switches

These switches make settings related to how the unit starts up. A label explaining the settings is affixed to the bottom panel.

**Making the settings**  
 Before changing the settings, turn off the power of the PSE. Even if you change the settings while the power is on, the changed settings are not applied until the power is turned off once.

For details, see below.

<b>Switch</b>	
<b>Status</b>	The switch is in the upward (OFF) position.
<b>Switch</b>	
<b>Status</b>	The switch is in the downward (ON) position.

### • Switches 1–3 (UNIT ID)

These switches specify the upper place of the UNIT ID; used in conjunction with the [UNIT ID] rotary switch described above which specifies the lower place, you can set the UNIT ID in a range of 127 possibilities.

#### Example setting)

#### Setting the UNIT ID to [0A]

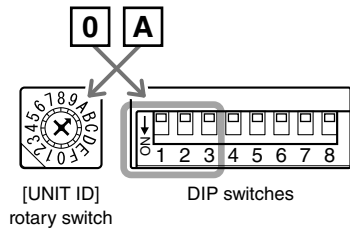



<b>Switch</b>	
<b>Setting</b>	UNIT ID is "0x"
<b>Function</b>	The [UNIT ID] rotary switch setting has a range of 01 through 0F.
<b>Switch</b>	
<b>Setting</b>	UNIT ID is "1x"
<b>Function</b>	The [UNIT ID] rotary switch setting has a range of 10 through 1F.

<b>Switch</b>	
<b>Setting</b>	UNIT ID is "2x"
<b>Function</b>	The [UNIT ID] rotary switch setting has a range of 20 through 2F.

<b>Switch</b>	
<b>Setting</b>	UNIT ID is "3x"
<b>Function</b>	The [UNIT ID] rotary switch setting has a range of 30 through 3F.

<b>Switch</b>	
<b>Setting</b>	UNIT ID is "4x"
<b>Function</b>	The [UNIT ID] rotary switch setting has a range of 40 through 4F.

<b>Switch</b>	
<b>Setting</b>	UNIT ID is "5x"
<b>Function</b>	The [UNIT ID] rotary switch setting has a range of 50 through 5F.

<b>Switch</b>	
<b>Setting</b>	UNIT ID is "6x"
<b>Function</b>	The [UNIT ID] rotary switch setting has a range of 60 through 6F.

<b>Switch</b>	
<b>Setting</b>	UNIT ID is "7x"
<b>Function</b>	The [UNIT ID] rotary switch setting has a range of 70 through 7F.

• **Switches 4–5**

Not used. Leave these in the factory-set position (upward).

• **Switch 6 (IP SETTING)**

Specifies how to set the IP address used for communicating with external devices.

<b>Switch</b>	
<b>Setting</b>	UNIT ID
<b>Content</b>	The IP address is determined by the UNIT ID, and will be "192.168.0.(UNIT ID)".



<b>Switch</b>	
<b>Setting</b>	PC
<b>Content</b>	The IP address is determined by the setting in MTX-MRX Editor (see "MTX-MRX Editor User Guide").

**NOTE**

You must set the "UNIT ID" the first time you connect this unit to a computer after purchase. Also, if you subsequently want to specify an IP address without using the UNIT ID, use MTX-MRX Editor to specify the IP address and then switch to "PC."

• **Switches 7-8 (START UP MODE)**

Specify how the unit is initialized after the power turns on.

<b>Switch</b>	 7 8
<b>Setting</b>	RESUME
<b>Content</b>	This is the normal operating mode. When the PGM1's power is turned on, it starts up while preserving the state in which it was immediately prior to powering-off.
<b>Switch</b>	 7 8
<b>Setting</b>	INT. (INITIALIZE)
<b>Content</b>	The unit is initialized to the factory settings (page 13).

③ **Dante/NETWORK connector**

This is an RJ-45 port for connecting a Dante device such as the MRX7-D using an Ethernet cable (CAT5e or better) via PSE.

**NOTE**

- Do not connect anything other than a Dante-enabled device or a device that supports gigabit Ethernet (including computers).
- The maximum cable length that can be used is 100 meters.
- Use STP (Shielded Twisted Pair) cable to prevent electromagnetic interference.

④ **SYNC indicator**

This indicator shows the operating status of the Dante network.

When the green indicator is lit, this indicates that the unit is the clock slave and that the clock is synchronized.

When the green indicator is flashing, this indicates that the unit is the clock master.

⑤ **LINK/ACT indicator**

This indicator shows the communication status of the Dante/NETWORK connector. If the Ethernet cable is connected correctly, the indicator flashes rapidly.

**Bottom Panel**

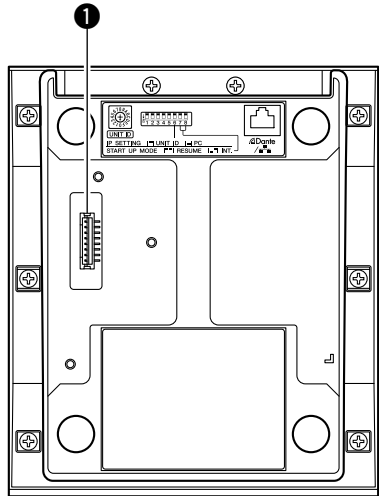

① **8-pin dedicated connector**

This is a dedicated connector for connection to the PGX1.

When the unit is shipped from the factory, a rubber cap is attached here.

# Controls and Connectors (PGX1)

## Top Panel

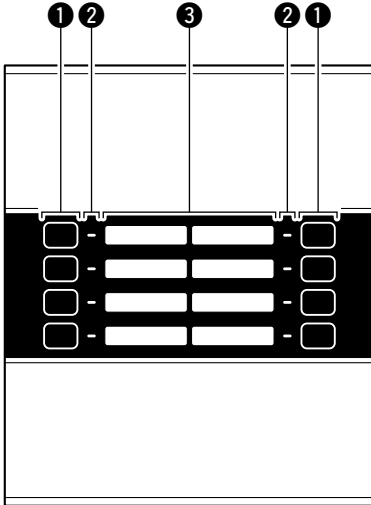

### 1 Zone/message select buttons

These buttons select the zone(s) to which the mic will broadcast, or select messages saved on the SD card. Use MTX-MRX Editor to assign zones or messages to these buttons. More than one broadcast zone can be selected at the same time. Only one message can be selected. For details on how to make settings, refer to “MTX-MRX Editor User Guide.”

### 2 Zone/message indicators

These indicators light to indicate the currently selected zone(s) or message.

### 3 Labels

Labels with the name of each zone can be inserted here. You can create labels using PGM1 Label Creator which is included with MTX-MRX Editor.

## Bottom Panel

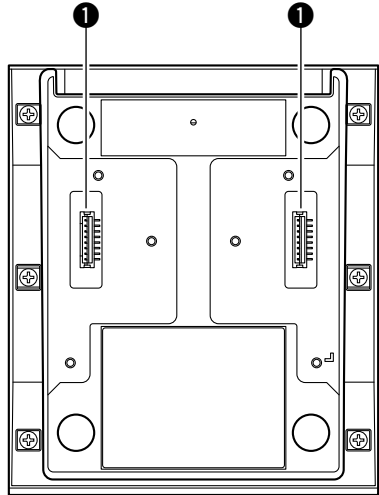

### 1 8-pin dedicated connector

This is a dedicated connector for connection to the PGM1 or PGX1.

# Initializing the PGM1

If you want to return (initialize) the unit to its factory-set state, for example because the installation location has changed, proceed as follows.

1. Power-off the PSE.
2. On the rear panel, set device settings DIP switch 7 to the downward position, and set switch 8 to the upward (INT.) position.

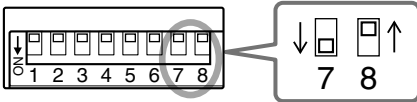

3. Power-on the PSE.  
Initialization begins.

- **Initialization in progress:**  
All zone indicators flash rapidly.
- **Initialization completed:**  
All zone indicators flash slowly.
- **Initialization failed:**  
The status indicator flashes slowly.

## NOTICE

Do not power-off the PSE while initialization is in progress. Doing so will cause malfunctions.

4. Verify that initialization is completed, and then power-off the PSE.
5. Set device settings DIP switches 7 and 8 both to the upward (RESUME) position.



6. Power-on the PSE.  
The unit starts up in the factory-set state.

# Connecting the PGM1 to an MTX/MRX system

Up to four PGM1 units can be connected to one MTX/MRX system.

Up to two PGX1 units can be connected to one PGM1 unit.

The PGM1 and PGX1 can control the parameters of any single MRX7-D or MTX5-D unit within the MTX/MRX system.

For details, refer to “MTX-MRX Editor User Guide.”

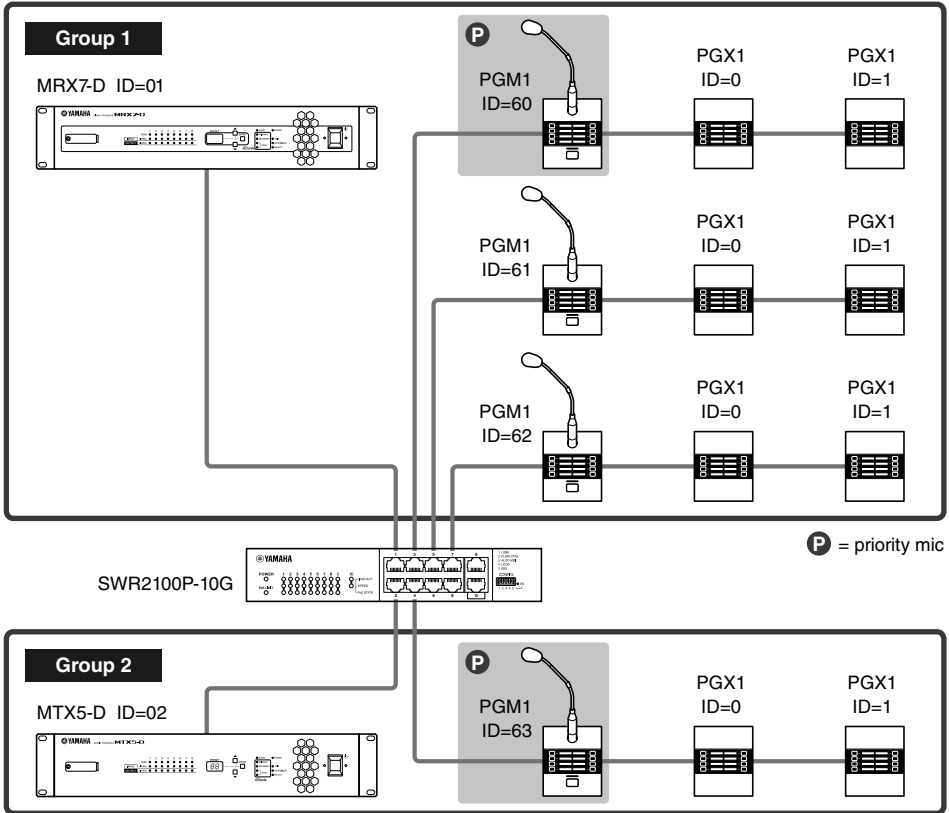

## About the priority mic

Of the PGM1 units connected to an MRX7-D or MTX5-D, one unit can be specified as the priority mic.

When the priority mic begins broadcasting, the other mics in the group are muted.

Within the group, mics other than the priority mic are given first-come first-served priority.

### NOTICE

Do not connect or disconnect cables while the PSE is on.

1. Use the rotary switch and DIP switches of each unit to specify its UNIT ID.
2. Connect a PoE network switch that can work with Dante within the Dante network, and use an Ethernet cable to connect the PGM1 to the network switch. If the network switch does not support PoE, connect a PoE injector between the network switch and the PGM1.

In some cases, the PSE (PoE network switch or PoE injector) might have ports that supply power and ports that do not supply power. Connect the PGM1 to a port that supplies power. For details on how to synchronize each device, refer to “MTX-MRX Editor User Guide.”

3. With the PGM1 and the PSE connected, power-on the PSE.

### Connections for a small system

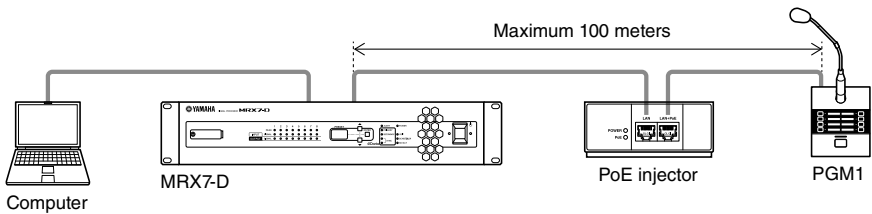

### Connections for a large system

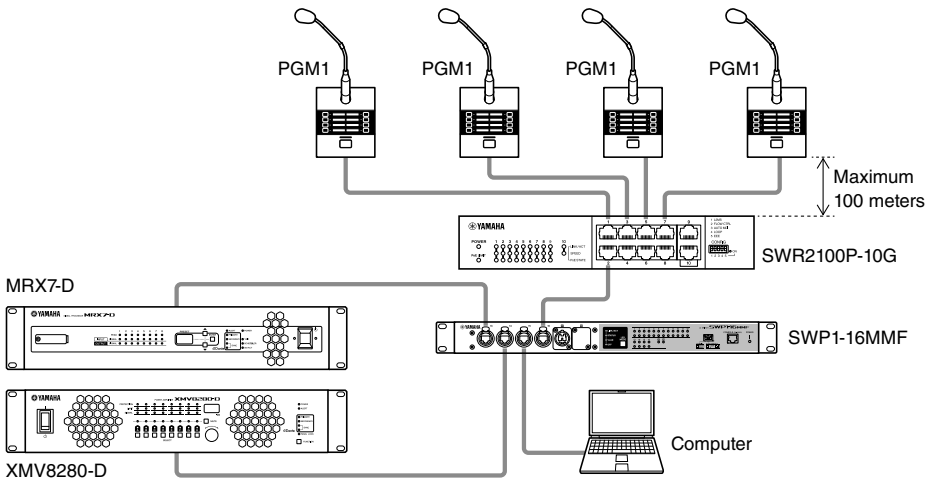

# Connecting a PGX1

Up to two PGX1 units can be connected to one PGM1 unit.

## NOTICE

- Before making connections, detach the Ethernet cable and gooseneck mic.
- Make sure to place a soft cloth underneath the device so that the surface of the body will not be damaged.

1. Turn the PGM1 and PGX1 units over on their back.
2. Place the PGM1 on the right, and place the PGX1 to be connected on the left.
3. Remove the rubber cap from the bottom panel of the PGM1.
4. Use the included connection cable to connect the PGM1 and PGX1.

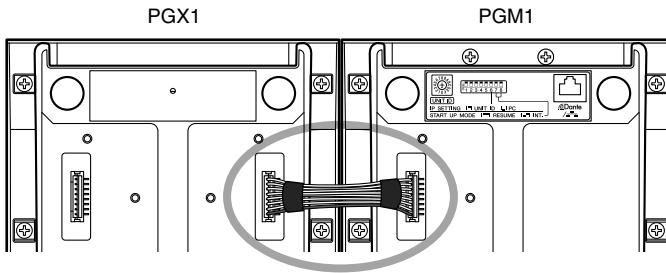

5. Place the connecting bracket between the two units, and fasten the screws (at the 8 locations shown below) on the PGX1 side to secure it.

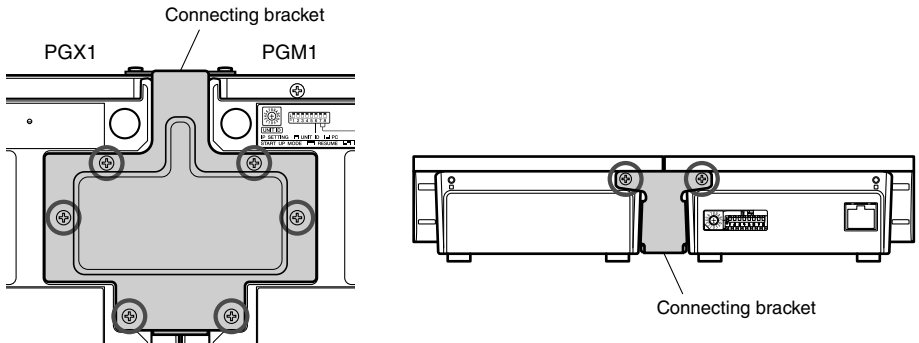

6. Place the rubber cap that you removed from PGM1 into the socket of the unused dedicated 8-pin connector of the PGX1.

If you want to connect a second PGX1 unit, you can do so in a similar way.

# Indicator list

## Status indicator

<b>Lit green</b>	Broadcast is possible
<b>Lit orange</b>	Broadcast is not possible because another mic is broadcasting
<b>Lit red</b>	Broadcasting
<b>Flashing red</b>	Preparing to broadcast
<b>Flashing orange</b>	Interrupted by the priority mic

## Indicator operation diagram

- \* Pressing PTT during broadcast will stop the broadcast.
- \* It is not necessary to press PTT when finished.

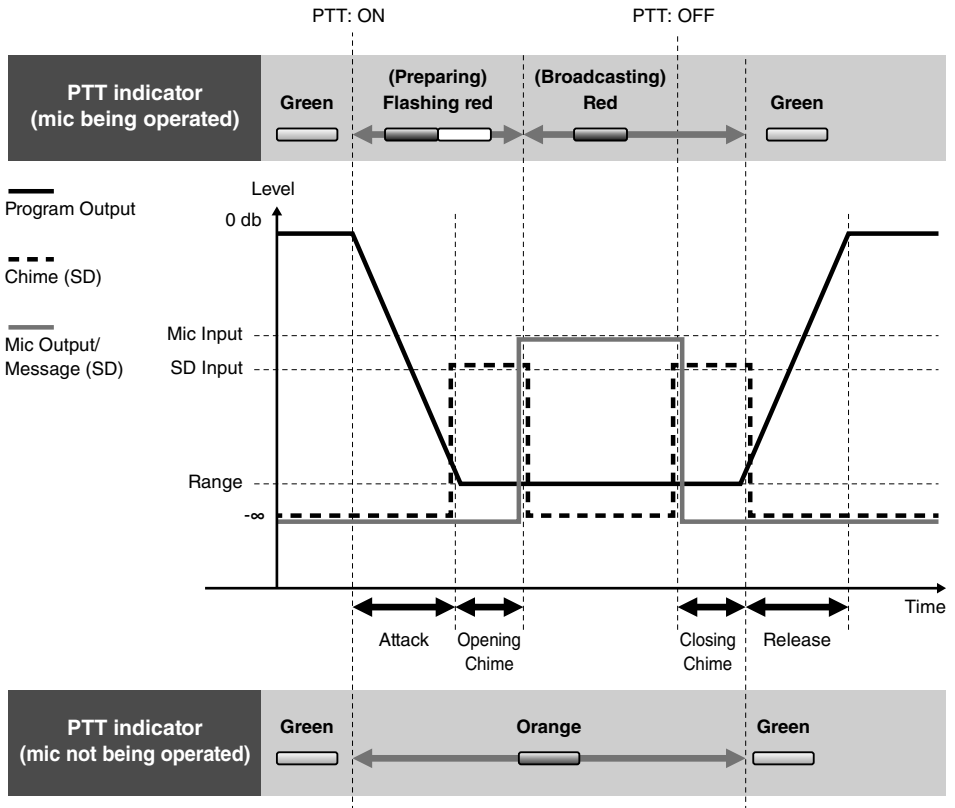

# Alert list

---

The following table lists the alerts generated by the PGM1/PGX1, their meaning, and the appropriate action to take.

When the status indicator flashes alternately in green and orange, the contents of the alert message are indicated at the position of the flashing zone / message indicator. The upper left zone / message indicator is set to alert number 1, and the lower right zone / message indicator is set to alert number 8.

If the problem cannot be solved, contact your Yamaha dealer listed at the end of this manual.

Flashing zone/ message indicator (alert number)	Meaning	Response
1	The device has not started up correctly.	Turn off the power of the PSE, then turn on after waiting at least 6 seconds. If this does not solve the problem, please initialize the PGM1. Should this also fail, contact your Yamaha dealer.
2	The data saved in internal memory has been lost.	
5	Duplicate IP addresses.	Change the IP addresses or UNIT ID so that there are no duplicates.
	IP address was not set within 60 seconds of startup.	Please check rear panel DIP switch 6 (IP SETTING). If DIP switch 6 is set to "PC," use the system's dedicated application software or the DHCP server to specify the device IP address.
6	The UNIT ID is set to "00."	Set the UNIT ID to something other than "00."
	Devices with identical UNIT IDs were found connected within the same network.	Change the UNIT ID so that there are no duplicates.

# Specifications

## General specifications

	PGM1	PGX1
<b>Dimensions</b>	132(W) × 56(H) × 154(D) mm (excluding mic)	132(W) × 56(H) × 154(D) mm
<b>Weight</b>	1.2 kg (including mic) 1.0 kg (excluding mic)	0.9 kg (excluding connecting bracket)
<b>Power supply voltage</b>	Power supplied via PoE (IEEE802.3af)	Power supplied from PGM1
<b>Power consumption</b>	4.8W max. (same whether PGM1 is used by itself or with an added PGX1)	
<b>Operating temperature range</b>	0°C–40°C	
<b>Storage temperature range</b>	-20°C–60°C	
<b>Maximum number of units usable simultaneously</b>	A maximum of two PGX1 units can be added for each PGM1 unit A maximum of four PGM1 units can be installed in one MTX/MRX system (There are limits on the total number of units within a system that includes other devices)	
<b>Included items</b>	Gooseneck mic, Zone label, Installation Manual	Zone label, Installation Manual, Connecting bracket, dedicated screws (8 pcs.), connection cable

## Electrical specifications

	PGM1
<b>Sampling frequency</b>	48kHz/44.1kHz
<b>Digital input/output format</b>	Dante
<b>Format Cable requirements</b>	Dante/NETWORK connector: 1000BASE-T Dante/NETWORK connector: CAT5e or better Ethernet STP cable

\* The contents of this manual apply to the latest specifications as of the publishing date. To obtain the latest manual, access the Yamaha website then download the manual file.

\* Der Inhalt dieser Bedienungsanleitung gilt für die neuesten technischen Daten zum Zeitpunkt der Veröffentlichung. Um die neueste Version der Anleitung zu erhalten, rufen Sie die Website von Yamaha auf und laden Sie dann die Datei mit der Bedienungsanleitung herunter.

\* Le contenu de ce mode d'emploi s'applique aux dernières caractéristiques techniques connues à la date de publication du manuel. Pour obtenir la version la plus récente du manuel, accédez au site Web de Yamaha puis téléchargez le fichier du manuel concerné.

\* El contenido de este manual se aplica a las últimas especificaciones según la fecha de publicación. Para obtener el último manual, acceda al sitio web de Yamaha y descargue el archivo del manual.

\* O conteúdo deste manual se aplica às especificações mais recentes a partir da data de publicação. Para obter o manual mais recente, acesse o site da Yamaha e faça o download do arquivo do manual.

\* Il contenuto del presente manuale si applica alle ultime specifiche tecniche a partire dalla data di pubblicazione. Per ottenere la versione più recente del manuale, accedere al sito Web Yamaha e scaricare il file corrispondente.

\* В содержании данного руководства приведены последние на момент публикации технические характеристики. Для получения последней версии руководства посетите веб-сайт корпорации Yamaha и загрузите файл с руководством.

\* 本書は、発行時点での最新仕様で説明しています。最新版は、ヤマハウェブサイトからダウンロードできます。

**European models**

Purchaser/User Information specified in EN55103-2:2009.

Conforms to Environments: E1, E2, E3 and E4

# Dimensions

Gooseneck  
microphone

PGM1

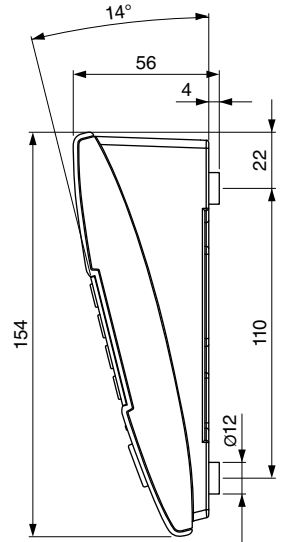
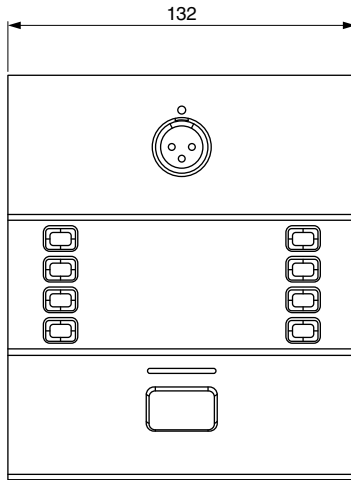
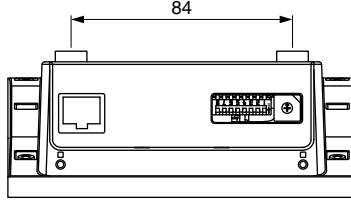
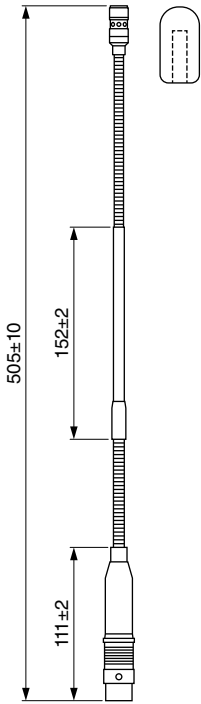

Unit: mm

**PGX1**

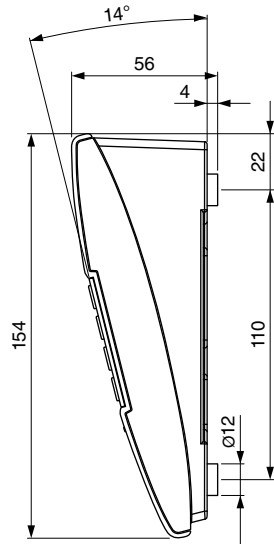
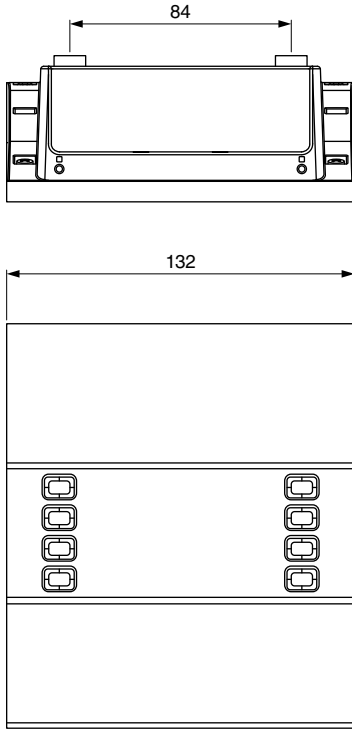

Unit: mm

# Important Notice: Guarantee Information for customers in European Economic Area (EEA) and Switzerland

<p><b>Important Notice: Guarantee Information for customers in EEA* and Switzerland</b></p> <p>For detailed guarantee information about this Yamaha product, and Pan-EEA* and Switzerland warranty service, please either visit the website address below (Printable file is available at our website) or contact the Yamaha representative office for your country. * EEA: European Economic Area</p>	<b>English</b>
<p><b>Wichtiger Hinweis: Garantie-Information für Kunden in der EWR* und der Schweiz</b></p> <p>Für nähere Garantie-Information über dieses Produkt von Yamaha, sowie über den Pan-EWR*- und Schweizer Garantieservice, besuchen Sie bitte entweder die folgend angegebene Internetadresse (eine druckfähige Version befindet sich auch auf unserer Webseite), oder wenden Sie sich an den für Ihr Land zuständigen Yamaha-Vertrieb. * EWR: Europäischer Wirtschaftsraum</p>	<b>Deutsch</b>
<p><b>Remarque importante: informations de garantie pour les clients de l'EEE et la Suisse</b></p> <p>Pour des informations plus détaillées sur la garantie de ce produit Yamaha et sur le service de garantie applicable dans l'ensemble de l'EEE ainsi qu'en Suisse, consultez notre site Web à l'adresse ci-dessous (le fichier imprimable est disponible sur notre site Web) ou contactez directement Yamaha dans votre pays de résidence. * EEE : Espace Economique Européen</p>	<b>Français</b>
<p><b>Belangrijke mededeling: Garantie-informatie voor klanten in de EER* en Zwitserland</b></p> <p>Voor gedetailleerde garantie-informatie over dit Yamaha-product en de garantieservice in hela EER* en Zwitserland, gaat u naar de onderstaande website (u vindt een afdrukbare bestand op onze website) of neemt u contact op met de vertegenwoordiging van Yamaha in uw land. * EER: Europese Economische Ruimte</p>	<b>Nederlands</b>
<p><b>Aviso importante: información sobre la garantía para los clientes del EEE* y Suiza</b></p> <p>Para una información detallada sobre este producto Yamaha y sobre el soporte de garantía en la zona EEE* y Suiza, visite la dirección web que se incluye más abajo (la versión del archivo para imprimir está disponible en nuestro sitio web) o póngase en contacto con el representante de Yamaha en su país. * EEE: Espacio Económico Europeo</p>	<b>Español</b>
<p><b>Avviso importante: informazioni sulla garanzia per i clienti residenti nell'EEA* e in Svizzera</b></p> <p>Per informazioni dettagliate sulla garanzia relativa a questo prodotto Yamaha e l'assistenza in garanzia nei paesi EEA* e in Svizzera, potete consultare il sito Web all'indirizzo riportato di seguito (è disponibile il file in formato stampabile) oppure contattare l'ufficio di rappresentanza locale della Yamaha. * EEA: Area Economica Europea</p>	<b>Italiano</b>
<p><b>Aviso importante: informações sobre as garantias para clientes da AEE* e da Suíça</b></p> <p>Para obter uma informação pormenorizada sobre este produto da Yamaha e sobre o serviço de garantia na AEE* e na Suíça, visite o site a seguir (o arquivo para impressão está disponível no nosso site) ou entre em contato com o escritório de representação da Yamaha no seu país. * AEE: Área Económica Europeia</p>	<b>Português</b>
<p><b>Σημαντική σημείωση: Πληροφορίες εγγύησης για τους πελάτες στον ΕΟΧ* και Ελλάδα</b></p> <p>Για λεπτομερείς πληροφορίες εγγύησης σχετικά με το παρόν προϊόν της Yamaha και την κάλυψη εγγύησης σε όλες τις χώρες του ΕΟΧ και την Ελλάδα, επισκεφτείτε την παρακάτω ιστοσελίδα (Εκτυπώσιμη μορφή είναι διαθέσιμη στην ιστοσελίδα μας) ή απευθυνθείτε στην αντιπροσωπεία της Yamaha στη χώρα σας. * ΕΟΧ: Ευρωπαϊκός Οικονομικός Χώρος</p>	<b>Ελληνικά</b>
<p><b>Viktigt: Garantierinformation för kunder i EES-området* och Schweiz</b></p> <p>För detaljerad information om denna Yamaha-produkt samt garantierinformation i hela EES-området* och Schweiz kan du antingen besöka nedanstående webbadress (en utskriftsvänlig fil finns på webbplatsen) eller kontakta Yamahas officiella representant i ditt land. * EES: Europeiska Ekonomiska Samarbetsområdet</p>	<b>Svenska</b>
<p><b>Viktig merknad: Garantierinformasjon for kunder i EØS* og Sveits</b></p> <p>Detaljert garantierinformasjon om dette Yamaha-produktet og garantierinformasjon for hele EØS-området* og Sveits kan fås enten ved å besøke nettstedene nedenfor (utskriftsversjon finnes på våre nettsider) eller kontakte Yamahas kontorene i landet der du bor. * EØS: Det europeiske økonomiske samarbeidsområdet</p>	<b>Norsk</b>
<p><b>Vigtig oplysning: Garantiplysninger til kunder i EØO* og Schweiz</b></p> <p>De kan finde detaljerede garantiplysninger om dette Yamaha-produkt og den fælles garantierordning for EØO* (og Schweiz) ved at besøge det websted, der er angivet nedenfor (der findes en fil, som kan udskrives, på vores websted), eller ved at kontakte Yamahas nationale repræsentationskontor i det land, hvor De bor. * EØO: Det Europæiske Økonomiske Område</p>	<b>Dansk</b>
<p><b>Tärkeä ilmoitus: Takuutiedot Euroopan talousalueen (ETA)* ja Sveitsin asiakkaille</b></p> <p>Tämän Yamaha-tuotteen sekä ETA-alueen ja Sveitsin takuuta koskevat yksityiskohtaiset tiedot saatte alla olevasta nettiosoitteesta. (Tuhostettava tiedosto saatavissa sivustollamme.) Voitte myös ottaa yhteyttä paikalliseen Yamaha-edustajaan. *ETA: Euroopan talousalue</p>	<b>Suomi</b>
<p><b>Ważne: Warunki gwarancyjne obowiązujące w EOG* i Szwajcarii</b></p> <p>Ali dowiedzieć się więcej na temat warunków gwarancyjnych tego produktu firmy Yamaha i serwisu gwarancyjnego w całym EOG* i Szwajcarii, należy odwiedzić wskazaną poniżej stronę internetową (Plik gotowy do wydruku znajduje się na naszej stronie internetowej) lub skontaktować się z przedstawicielstwem firmy Yamaha w swoim kraju. * EOG — Europejski Obszar Gospodarczy</p>	<b>Polski</b>
<p><b>Dôležité oznámenie: Záruční informace pro zákazníky v EHS* a ve Švýcarsku</b></p> <p>Podrobné záruční informácie o tomto produkte Yamaha a záručnímservise v celom EHS* a ve Švýcarsku naleznete na nižšie uvedené webové adrese (soubor k tisku je dostupný na našich webových stránkách) nebo se můžete obrátit na zastoupení firmy Yamaha ve své zemi. * EHS: Evropský hospodářský prostor</p>	<b>Česky</b>
<p><b>Fontos figyelmeztetés: Garancia-információk az EGT* területén és Svájcban élő vásárlók számára</b></p> <p>A jelen Yamaha termékre vonatkozó részletes garancia-információk, valamint az EGT*-re és Svájcra kiterjedő garanciális szolgáltatás tekintetében keresse fel webhelyünket az alábbi címen (a webhelyen nyomtatható fájl is talál), vagy pedig lépjen kapcsolatba az országában működő Yamaha képviselői irodával. * EGT: Európai Gazdasági Térség</p>	<b>Magyar</b>
<p><b>Oluline märkus: Garantiteave Euroopa Majanduspiirkonna (EMP)* ja Šveitsi klientidele</b></p> <p>Täpsem teabe saamiseks selle Yamaha toote garantii ning kogu Euroopa Majanduspiirkonna ja Šveitsi garantiteeninduse kohta, külastage palun veebisaiti alljärgneval aadressil (meie saidil on saadaval printitav fail) või pöörduge Teie regiooni Yamaha esinduse poole. * EMP: Euroopa Majanduspiirkond</p>	<b>Eesti keel</b>
<p><b>Svarīgs paziņojums: garantijas informācija klientiem EEE* un Šveicē</b></p> <p>Lai saņemtu detalizētu garantijas informāciju par šo Yamaha produktu, kā arī garantijas apkalpošanu EEE* un Šveicē, lūdzam apmeklēt zemāk norādīto tīmekļa vietnes adresi (tīmekļa vietnē ir pieejams drukājams fails) vai sazinieties ar jūsu valsti apkalpojamo Yamaha pārstāvniecību. * EEE: Eiropas Ekonomikas zona</p>	<b>Latviešu</b>
<p><b>Dėmesio: informacija dėl garantijos pirkejamiems EEE* ir Šveicarijoje</b></p> <p>Jei reikia išsamioms informacijos apie šį Yamaha produktą ir jo techninę priežiūrą visoje EEE* ir Šveicarijoje, apsilankykite mūsų svetainėje toliau nurodytu adresu (svetainėje yra spausdintinas failas) arba kreipkitės į „Yamaha“ atstovybę savo šalyje. * EEE – Europos ekonominė erdvė</p>	<b>Lietuvių kalba</b>
<p><b>Dôležité upozornenie: Informácie o záruke pre zákazníkov v EHP* a Švajčiarsku</b></p> <p>Podrobné informácie o záruke týkajúcej sa tohto produktu od spoločnosti Yamaha a garančnom servise v EHP* a Švajčiarsku nájdete na webovej stránke uvedenej nižšie (na našej webovej stránke je k dispozícii súbor na tlač) alebo sa obráťte na zástupcu spoločnosti Yamaha vo svojej krajine. * EHP: Európsky hospodársky priestor</p>	<b>Slovenčina</b>
<p><b>Pomembno obvestilo: Informacije o garanciji za kupce v EGP* in Švici</b></p> <p>Za podrobnejše informacije o tem Yamahinem izdelku ter garancijskem servisu v celotnem EGP in Švici, obiščite spletno mesto, ki je navedeno spodaj (natisljiva datoteka je na voljo na našem spletnem mestu), ali se obrnite na Yamahinega predstavnika v svoji državi. * EGP: Evropski gospodarski prostor</p>	<b>Slovenščina</b>
<p><b>Важно съобщение: Информация за гаранцията за клиентите в ЕИП* и Швейцария</b></p> <p>За подробна информация за гаранцията за този продукт на Yamaha и гаранционното обслужване в паневропейската зона на ЕИП* и Швейцария или посетете посочения по-долу уеб сайт (на нашия уеб сайт има файл за печат), или се свържете с представителния офис на Yamaha във вашата страна. * ЕИП: Европейско икономическо пространство</p>	<b>Български език</b>
<p><b>Notificare importantă: Informații despre garanție pentru clienții din SEE* și Elveția</b></p> <p>Pentru informații detaliate privind acest produs Yamaha și serviciul de garanție Pan-SEE* și Elveția, vizitați site-ul la adresa de mai jos (fișierul imprimabil este disponibil pe site-ul nostru) sau contactați biroul reprezentanței Yamaha din țara dumneavoastră. * SEE: Spațiul Economic European</p>	<b>Limba română</b>

<http://europe.yamaha.com/warranty/>

URL\_4

### Information for users on collection and disposal of old equipment



This symbol on the products, packaging, and/or accompanying documents means that used electrical and electronic products should not be mixed with general household waste. For proper treatment, recovery and recycling of old products, please take them to applicable collection points, in accordance with your national legislation.

By disposing of these products correctly, you will help to save valuable resources and prevent any potential negative effects on human health and the environment which could otherwise arise from inappropriate waste handling.

For more information about collection and recycling of old products, please contact your local municipality, your waste disposal service or the point of sale where you purchased the items.

#### For business users in the European Union:

If you wish to discard electrical and electronic equipment, please contact your dealer or supplier for further information.

#### Information on Disposal in other Countries outside the European Union:

This symbol is only valid in the European Union. If you wish to discard these items, please contact your local authorities or dealer and ask for the correct method of disposal.

(weee\_eu\_en\_02)

### Verbraucherinformation zur Sammlung und Entsorgung alter Elektrogeräte



Befindet sich dieses Symbol auf den Produkten, der Verpackung und/oder beiliegenden Unterlagen, so sollten benutzte elektrische Geräte nicht mit dem normalen Haushaltsabfall entsorgt werden. In Übereinstimmung mit Ihren nationalen Bestimmungen bringen Sie alte Geräte bitte zur fachgerechten Entsorgung, Wiederaufbereitung und Wiederverwendung zu den entsprechenden Sammelstellen.

Durch die fachgerechte Entsorgung der Elektrogeräte helfen Sie, wertvolle Ressourcen zu schützen, und verhindern mögliche negative Auswirkungen auf die menschliche Gesundheit und die Umwelt, die andernfalls durch unsachgerechte Müllentsorgung auftreten könnten.

Für weitere Informationen zum Sammeln und Wiederaufbereiten alter Elektrogeräte kontaktieren Sie bitte Ihre örtliche Stadt- oder Gemeindeverwaltung, Ihren Abfallentsorgungsdienst oder die Verkaufsstelle der Artikel.

#### Information für geschäftliche Anwender in der Europäischen Union:

Wenn Sie Elektrogeräte ausrangieren möchten, kontaktieren Sie bitte Ihren Händler oder Zulieferer für weitere Informationen.

#### Entsorgungsinformation für Länder außerhalb der Europäischen Union:

Dieses Symbol gilt nur innerhalb der Europäischen Union. Wenn Sie solche Artikel ausrangieren möchten, kontaktieren Sie bitte Ihre örtlichen Behörden oder Ihren Händler und fragen Sie nach der sachgerechten Entsorgungsmethode.

(weee\_eu\_de\_02)

### Informations concernant la collecte et le traitement des déchets d'équipements électriques et électroniques



Le symbole sur les produits, l'emballage et/ou les documents joints signifie que les produits électriques ou électroniques usagés ne doivent pas être mélangés avec les déchets domestiques habituels. Pour un traitement, une récupération et un recyclage appropriés des déchets d'équipements électriques et électroniques, veuillez les déposer aux points de collecte prévus à cet effet, conformément à la réglementation nationale.

En vous débarrassant correctement des déchets d'équipements électriques et électroniques, vous contribuerez à la sauvegarde de précieuses ressources et à la prévention de potentiels effets négatifs sur la santé humaine qui pourraient advenir lors d'un traitement inapproprié des déchets.

Pour plus d'informations à propos de la collecte et du recyclage des déchets d'équipements électriques et électroniques, veuillez contacter votre municipalité, votre service de traitement des déchets ou le point de vente où vous avez acheté les produits.

#### Pour les professionnels dans l'Union européenne:

Si vous souhaitez vous débarrasser des déchets d'équipements électriques et électroniques, veuillez contacter votre vendeur ou fournisseur pour plus d'informations.

#### Informations sur la mise au rebut dans d'autres pays en dehors de l'Union européenne:

Ce symbole est seulement valable dans l'Union européenne. Si vous souhaitez vous débarrasser de déchets d'équipements électriques et électroniques, veuillez contacter les autorités locales ou votre fournisseur et demander la méthode de traitement appropriée.

(weee\_eu\_fr\_02)

### Información para usuarios sobre la recogida y eliminación de los equipos antiguos



Este símbolo en los productos, embalajes y documentos anexos significa que los productos eléctricos y electrónicos no deben mezclarse con los desperdicios domésticos normales.

Para el tratamiento, recuperación y reciclaje apropiados de los productos antiguos, llévelos a puntos de reciclaje correspondientes, de acuerdo con la legislación nacional.

Al deshacerse de estos productos de forma correcta, ayudará a ahorrar recursos valiosos y a impedir los posibles efectos desfavorables en la salud humana y en el entorno que de otro modo se producirían si se trataran los desperdicios de modo inapropiado.

Para obtener más información acerca de la recogida y el reciclaje de los productos antiguos, póngase en contacto con las autoridades locales, con el servicio de eliminación de basuras o con el punto de venta donde adquirió los artículos.

#### Para los usuarios empresariales de la Unión Europea:

Si desea desechar equipos eléctricos y electrónicos, póngase en contacto con su vendedor o proveedor para obtener más información.

#### Información sobre la eliminación en otros países fuera de la Unión Europea:

Este símbolo solo es válido en la Unión Europea. Si desea desechar estos artículos, póngase en contacto con las autoridades locales o con el vendedor y pregúnteles el método correcto.

(weee\_eu\_es\_02)

### Informações para os utilizadores relativas à recolha e eliminação de equipamentos usados



Este símbolo, presente em produtos, embalagens e/ou incluído na documentação associada, indica que os produtos elétricos e eletrônicos usados não devem ser eliminados juntamente com os resíduos domésticos em geral.

O procedimento correto consiste no tratamento, recuperação e reciclagem de produtos usados, pelo que deve proceder à respetiva entrega nos pontos de recolha adequados, em conformidade com a legislação nacional em vigor.

A eliminação destes produtos de forma adequada permite poupar recursos valiosos e evitar potenciais efeitos prejudiciais para a saúde pública e para o ambiente, associados ao processamento incorreto dos resíduos.

Para mais informações relativas à recolha e reciclagem de produtos usados, contacte as autoridades locais, o serviço de eliminação de resíduos ou o ponto de venda onde foram adquiridos os itens relevantes.

#### Informações para utilizadores empresariais na União Europeia:

Para proceder à eliminação de equipamento elétrico e eletrónico, contacte o seu revendedor ou fornecedor para obter informações adicionais.

#### Informações relativas à eliminação em países não pertencentes à União Europeia:

Este símbolo é válido exclusivamente na União Europeia. Caso pretenda eliminar este tipo de itens, contacte as autoridades locais ou o seu revendedor e informe-se acerca do procedimento correto para proceder à respetiva eliminação.

(weee\_eu\_pt\_02a)

### Informazioni per gli utenti sulla raccolta e lo smaltimento di vecchia attrezzatura



Questi simboli sui prodotti, sull'imballaggio e/o sui documenti che li accompagnano, indicano che i prodotti elettrici ed elettronici non devono essere mischiati con i rifiuti generici.

Per il trattamento, il recupero e il riciclaggio appropriato di vecchi prodotti, si prega di portarli ai punti di raccolta designati, in accordo con la legislazione locale.

Smaltendo correttamente questi prodotti si potranno recuperare risorse preziose, oltre a prevenire potenziali effetti negativi sulla salute e l'ambiente che potrebbero sorgere a causa del trattamento improprio dei rifiuti.

Per ulteriori informazioni sulla raccolta e il riciclaggio di vecchi prodotti, si prega di contattare l'amministrazione comunale locale, il servizio di smaltimento dei rifiuti o il punto vendita dove sono stati acquistati gli articoli.

#### Per utenti imprenditori dell'Unione europea:

Se si desidera scartare attrezzatura elettrica ed elettronica, si prega di contattare il proprio rivenditore o il proprio fornitore per ulteriori informazioni.

#### Informazioni sullo smaltimento negli altri Paesi al di fuori dell'Unione europea:

Questi simboli sono validi solamente nell'Unione Europea; se si desidera scartare questi articoli, si prega di contattare le autorità locali o il rivenditore e richiedere informazioni sulla corretta modalità di smaltimento.

(weee\_eu\_it\_02)

## ADDRESS LIST

### NORTH AMERICA

#### CANADA

**Yamaha Canada Music Ltd.**  
135 Milner Avenue, Toronto, Ontario,  
M1S 3R1, Canada  
Tel: +1-416-298-1311

#### U.S.A.

**Yamaha Corporation of America**  
6600 Orangefhorpe Avenue, Buena Park, CA 90620,  
U.S.A.  
Tel: +1-714-522-9011

### CENTRAL & SOUTH AMERICA

#### MEXICO

**Yamaha de México, S.A. de C.V.**  
Av. Insurgentes Sur 1647 Piso 9, Col. San José  
Insurgentes, Delegación Benito Juárez, México,  
D.F., C.P. 03900, México  
Tel: +52-55-5804-0600

#### BRAZIL

**Yamaha Musical do Brasil Ltda.**  
Rua Fidêncio Ramos, 302 – Cj 52 e 54 – Torre B – Vila  
Olimpia – CEP 04551-010 – São Paulo/SP, Brazil  
Tel: +55-11-3704-1377

#### ARGENTINA

**Yamaha Music Latin America, S.A.,  
Sucursal Argentina**  
Olga Cossettini 1533, Piso 4 Norte,  
Madero Este-C1107CEK,  
Buenos Aires, Argentina  
Tel: +54-11-4119-7000

#### PANAMA AND OTHER LATIN AMERICAN COUNTRIES/ CARIBBEAN COUNTRIES

**Yamaha Music Latin America, S.A.**  
Edif. Torre Banco General, Piso 7, Urbanización  
Marbella, Calle 47 y Aquilino de la Guardia,  
Ciudad de Panamá, República de Panamá  
Tel: +507-269-5311

### EUROPE

#### THE UNITED KINGDOM/IRELAND

**Yamaha Music Europe GmbH (UK)**  
Sherbourne Drive, Tilbrook, Milton Keynes,  
MK7 8BL, U.K.  
Tel: +44-1908-366700

#### GERMANY

**Yamaha Music Europe GmbH**  
Siemensstrasse 22-34, 25462 Rellingen, Germany  
Tel: +49-4101-303-0

#### SWITZERLAND/LIECHTENSTEIN

**Yamaha Music Europe GmbH, Branch  
Switzerland in Thalwil**  
Seestrasse 18a, 8800 Thalwil, Switzerland  
Tel: +41-44-3878080

#### AUSTRIA/BULGARIA/ CZECH REPUBLIC/HUNGARY/ ROMANIA/SLOVAKIA/SLOVENIA

**Yamaha Music Europe GmbH  
Branch Austria**  
Schleiergasse 20, 1100 Wien, Austria  
Tel: +43-1-60203900

#### POLAND

**Yamaha Music Europe GmbH  
Sp.z o.o. Oddział w Polsce**  
ul. Wielicka 52, 02-657 Warszawa, Poland  
Tel: +48-22-880-08-88

#### MALTA

**Olimpus Music Ltd.**  
Valletta Road, Mosta MST9010, Malta  
Tel: +356-2133-2093

#### NETHERLANDS/BELGIUM/ LUXEMBOURG

**Yamaha Music Europe Branch Benelux**  
Clairissenhof 5b, 4133 AB Vianen, The Netherlands  
Tel: +31-347-358040

#### FRANCE

**Yamaha Music Europe**  
7 rue Ambroise Croizat, Zone d'activités de Pariest,  
77183 Croissy-Beaubourg, France  
Tel: +33-1-6461-4000

#### ITALY

**Yamaha Music Europe GmbH, Branch Italy**  
Via Tinelli N.67/69 20855 Gemo di Lesmo (MB),  
Italy  
Tel: +39-039-9065-1

#### SPAIN/PORTUGAL

**Yamaha Music Europe GmbH Ibérica, Sucursal  
en España**  
Ctra. de la Coruña km. 17,200, 28231  
Las Rozas de Madrid, Spain  
Tel: +34-91-639-88-88

#### GREECE

**Philippou Nakas S.A. The Music House**  
19th km. Leof. Lavriou 190 02 Peania – Attiki,  
Greece  
Tel: +30-210-6686168

#### SWEDEN/FINLAND/ICELAND

**Yamaha Music Europe GmbH Germany filial  
Scandinavia**  
JA Wetterengsgata 1, 400 43 Göteborg, Sweden  
Tel: +46-31-89-34-00

#### DENMARK

**Yamaha Music Denmark,  
Filial of Yamaha Music Europe GmbH, Tyskland**  
Generatorvej 8C, ST. TH., 2860 Soborg, Denmark  
Tel: +45-44-92-49-00

#### NORWAY

**Yamaha Music Europe GmbH Germany -  
Norwegian Branch**  
Grini Næringspark 1, 1332 Osterås, Norway  
Tel: +47-6716-7800

#### CYPRUS

**Yamaha Music Europe GmbH**  
Siemensstrasse 22-34, 25462 Rellingen, Germany  
Tel: +49-4101-303-0

#### RUSSIA

**Yamaha Music (Russia) LLC.**  
Room 37, entrance 7, bld. 7, Kievskaya street,  
Moscow, 121059, Russia  
Tel: +7-495-626-5005

#### OTHER EUROPEAN COUNTRIES

**Yamaha Music Europe GmbH**  
Siemensstrasse 22-34, 25462 Rellingen, Germany  
Tel: +49-4101-3030

### AFRICA

**Yamaha Music Gulf FZE**  
JAFZA-16, Office 512, P.O.Box 17328,  
Jebel Ali FZE, Dubai, UAE  
Tel: +971-4-801-1500

### MIDDLE EAST

#### TURKEY

**Yamaha Music Europe GmbH  
Merkezi Almanya Türkiye İstanbul Şubesi**  
Mor Sumbul Sokak Varyap Meridian Business  
1.Blok No:1 113-114-115  
Bati Atasehir Istanbul, Turkey  
Tel: +90-216-275-7960

#### OTHER COUNTRIES

**Yamaha Music Gulf FZE**  
JAFZA-16, Office 512, P.O.Box 17328,  
Jebel Ali FZE, Dubai, UAE  
Tel: +971-4-801-1500

### ASIA

#### THE PEOPLE'S REPUBLIC OF CHINA

**Yamaha Music & Electronics (China) Co., Ltd.**  
2F, Yunhedasha, 1818 Xinzha-lu, Jingnan-qu,  
Shanghai, China  
Tel: +86-400-051-7700

#### INDIA

**Yamaha Music India Private Limited**  
P-401, JMD Megapolis, Sector-48, Sohna Road,  
Gurgaon-120218, Haryana, India  
Tel: +91-124-485-3300

#### INDONESIA

**PT. Yamaha Musik Indonesia (Distributor)**  
Yamaha Music Center Bldg. Jalan Jend. Gatot  
Subroto Kav. 4, Jakarta 12930, Indonesia  
Tel: +62-21-520-2577

#### KOREA

**Yamaha Music Korea Ltd.**  
11F, Prudential Tower, 298, Gangnam-daero,  
Gangnam-gu, Seoul, 06253, Korea  
Tel: +82-2-3467-3300

#### MALAYSIA

**Yamaha Music (Malaysia) Sdn. Bhd.**  
No.8, Jalan Perbandaran, Kelana Jaya, 47301  
Petaling Jaya, Selangor, Malaysia  
Tel: +60-3-78030900

#### SINGAPORE

**Yamaha Music (Asia) Private Limited**  
Block 202 Hougang Street 21, #02-00,  
Singapore 530202, Singapore  
Tel: +65-6740-9200

#### TAIWAN

**Yamaha Music & Electronics Taiwan Co., Ltd.**  
2F, No.1, Yuandong Rd., Banqiao Dist.,  
New Taipei City 22063, Taiwan (R.O.C.)  
Tel: +886-2-7741-8888

#### THAILAND

**Siam Music Yamaha Co., Ltd.**  
3, 4, 15, 16th Fl., Siam Motors Building,  
891/1 Rama 1 Road, Wangmai,  
Pathumwan, Bangkok 10330, Thailand  
Tel: +66-2215-2622

#### VIETNAM

**Yamaha Music Vietnam Company Limited**  
15th Floor, Nam A Bank Tower, 201-203 Cach  
Mang Thang Tam St., Ward 4, Dist.3,  
Ho Chi Minh City, Vietnam  
Tel: +84-8-3818-1122

#### OTHER ASIAN COUNTRIES

<http://asia.yamaha.com/>

### OCEANIA

#### AUSTRALIA

**Yamaha Music Australia Pty. Ltd.**  
Level 1, 80 Market Street, South Melbourne,  
VIC 3205, Australia  
Tel: +61-3-9693-5111

#### COUNTRIES AND TRUST TERRITORIES IN PACIFIC OCEAN

<http://asia.yamaha.com/>

PA52

Head Office/Manufacturer: Yamaha Corporation 10-1, Nakazawa-cho, Naka-ku, Hamamatsu, 430-8650, Japan  
(For European Countries) Importer: Yamaha Music Europe GmbH Siemensstrasse 22-34, 25462 Rellingen, Germany

Yamaha Pro Audio global website  
<https://www.yamaha.com/proaudio/>

Yamaha Downloads  
<https://download.yamaha.com/>

Manual Development Group  
© 2017 Yamaha Corporation

Published 05/2018 POES-C0

**VAM0500**