



See the possibilities

User Manual

Sweep Series - GigE Vision Interface

SW-2005TL-5GE

SW-2005M-5GE

SW-4005BL-5GE

SW-4005M-5GE



Digital CMOS Progressive Line Scan Camera (Trilinear, Bilinear and Monochrome)

Document Version: 1.4

Date: 2025-10-22

Thank you for purchasing this product.

 Be sure to read this documentation before use.

This documentation includes important safety precautions and instructions on how to operate the unit. Be sure to read this documentation to ensure proper operation.

The contents of this documentation are subject to change without notice for the purpose of improvement.

Table of Contents

Table of Contents	2
About Technical Note	6
Notice/Warranty	7
Notice	7
Warranty	7
Certifications	7
CE Compliance	7
FCC	7
Warning	8
KC	8
China RoHS	9
Usage Precautions	10
Notes on Cable Configurations	10
Notes on LAN Cable Connection	10
Notes on Attaching the Lens	10
Phenomena Specific to CMOS Image Sensors	11
Notes on Exportation	11
Features	12
Package Contents, Accessories	13
Parts Identification	14
Lens Mount (C-Mount)	14
Connectors	14
DC IN/TRIG Connector (12-Pin Round)	15
RJ-45 Connector	15
LEDs	16
Mounting Holes	17
Recommended External Input Circuit Diagram	17
Preparation	18
Step 1: Install the Software (First Time Only)	18
Step 2: Connect Devices	19

① Lens	19
② Mounting	20
③ LAN Cable	20
④ Network Card	20
⑤ DC IN / Trigger IN Connection Cable	21
⑥ AC Adapter (Power Supply, If Necessary)	21
Step 3: Verify Camera Operation	21
Step 4: Verify the Connection between the Camera and PC	22
Step 5: Configure Trigger, Exposure, and Line Rate Settings	24
Control via External Triggers with the Specified Exposure Time	25
Control via External Triggers without Specifying the Exposure Time	26
Control via External Triggers with Exposure Time Controlled by the Pulse Width of the Trigger Input Signal	27
Control without External Triggers with the Specified Exposure Time	28
Control without External Triggers without Specifying the Exposure Time	28
Step 6: Adjust the Image Quality	29
DSNU Correction (Pixel Black Correct)	29
PRNU Correction (Pixel Gain Correct)	30
Adjust the Gain	33
Adjust the White Balance	35
Adjust the Black Level	38
Step 7: Save the Settings	38
To Save User Settings	39
To Load User Settings	39
Main Functions	40
ROI (Regional Scanning Function)	40
Binning Function	42
Image Flip Function (ReverseX)	43
Pixel Format	43
BiColorRGBG / BiColorBGRG Steam Data Alignment	45
Bicolor Pixel Format Data Array	46
Acquisition Control	48

Change the Line Rate	48
Maximum Line Rates (Approximate)	49
Trigger Control	51
Image Output Delay	52
Frame Start Trigger	53
FrameStart Trigger and AcquisitionTransferStart Trigger	54
Exposure Mode	55
Actual Exposure Time	58
Delay Time from Trigger Input to Start of Exposure	59
Timing Chart	60
ExposureMode = Timed	61
ExposureMode = Off	63
ExposureMode = TriggerWidth	65
GPIO (Digital Input/Output Settings)	67
LineSource Items	68
ExposureActive Signal	69
Pulse Generator	70
Gain Control	71
Sensor Gain Mode	72
Gamma Function	74
LUT (Lookup Table)	75
Color Space Conversion (ColorTransformationControl)	76
Shading Correction	77
How to Configure the Shading Correction Function	78
Pixel Sensitivity Correction (DSNU, PRNU)	80
Chromatic Aberration Correction	81
Tilt View Correction	84
Crosstalk Compensation Mode	85
Noise Reduction Filter Functions	87
Spatial Compensation	88
Trilinear Model	88
Bilinear Model	90

Counter and Timer Control	91
Connecting Rotary Encoders	93
EncoderDivider Trigger Option	95
EdgeDetection Trigger Option	97
Resume Scanning (Backward Counter)	98
Rotation Direction	98
Logic Block Control	99
Action Control Function	100
PTP (Precision Time Protocol)	101
Chunk Data Function	102
Event Control Function	102
Setting List (Feature Properties)	104
DeviceControl	105
Transport Layer Control	107
ImageFormatControl	111
AcquisitionControl	114
DigitalIOControl	116
PulseGenerator	119
AnalogControl	121
LUT Control	123
Color Transformation Control	124
Shading	125
Correction	126
SpatialControl	129
Counter and Timer Control	130
EncoderControl	131
Logic Block Control	133
ActionControl	134
ChunkDataControl	134
EventControl	137
UserSetControl	140

Miscellaneous	141
Troubleshooting	141
Specifications	142
Spectral Response (Color model)	147
Spectral Response (Monochrome model)	148
Dimensions	149
Comparison of the Decibel Display and Multiplier Display	150
User's Record	151
Appendix	152
Revision History	153

About Technical Note



Some additional technical information is provided on the JAI website as Technical Notes. In this manual, if a technical note is available for a particular topic, the above icon is shown. Please refer to the following URL for Technical notes.

<https://www.jai.com/support-software/technical-notes>

Notice/Warranty

Notice

The material contained in this manual consists of information that is proprietary to JAI Ltd., Japan, and may only be used by the purchasers of the product. JAI Ltd., Japan makes no warranty for the use of its product and assumes no responsibility for any errors which may appear or for damages resulting from the use of the information contained herein. JAI Ltd., Japan reserves the right to make changes without notice.

Company and product names mentioned in this manual are trademarks or registered trademarks of their respective owners.

Warranty

For information about the warranty, please contact your factory representative.

Certifications

CE Compliance

As defined by the Directive 2004/108/EC of the European Parliament and of the Council, EMC (Electromagnetic compatibility), JAI Ltd., Japan declares that the below model(s) comply with the following provisions applying to their standards.

Models	Comply With
SW-2005TL-5GE	EMI: EN55032:2015/A11:2020 EMS: EN55035:2017(CISPR35:2016)
SW-2005M-5GE	
SW-4005BL-5GE	
SW-4005M-5GE	

FCC

This equipment has been tested and found to comply with the limits for a Class B digital device, pursuant to Part 15 of the FCC Rules. These limits are designed to provide reasonable protection against harmful interference in a residential installation. This equipment generates, uses and can radiate radio frequency energy and, if not installed and used in accordance with the instructions, may cause harmful interference to radio communications. However, there is no guarantee that interference will not occur in a particular installation. If this equipment does cause harmful interference to radio or television reception, which can be determined by turning the equipment off and on, the user is encouraged to try to correct the interference by one or more of the following measures:

- Reorient or relocate the receiving antenna.
- Increase the separation between the equipment and receiver.

- Connect the equipment into an outlet on a circuit different from that to which the receiver is connected.
- Consult the dealer or an experienced radio/TV technician for help.

Warning

Changes or modifications to this unit not expressly approved by the party responsible for FCC compliance could void the user's authority to operate the equipment.

KC

	상 호:	JAI Ltd. Japan
	기자재명칭:	Industrial Camera
	모 델 명:	SW-2005TL-5GE
	제조사 및 제조국가:	JAI Ltd., Japan / JAPAN
JAI-SW-2005M-5GE		

	상 호:	JAI Ltd. Japan
	기자재명칭:	Industrial Camera
	모 델 명:	SW-2005M-5GE
	제조사 및 제조국가:	JAI Ltd., Japan / JAPAN
JAI-SW-2005M-5GE		

	상 호:	JAI Ltd. Japan
	기자재명칭:	Industrial Camera
	모 델 명:	SW-4005BL-5GE
	제조사 및 제조국가:	JAI Ltd., Japan / JAPAN
JAI-SW-2005M-5GE		

	상 호:	JAI Ltd. Japan
	기자재명칭:	Industrial Camera
	모 델 명:	SW-4005M-5GE
	제조사 및 제조국가:	JAI Ltd., Japan / JAPAN
JAI-SW-2005M-5GE		

제조년월은 제품상자의 라벨을 참조하십시오.

China RoHS

The following statement is related to the regulation on “Measures for the Administration of the Control of Pollution by Electronic Information Products”, known as “China RoHS”. The table shows contained Hazardous Substances in this camera.

 mark shows that the environment-friendly use period of contained Hazardous Substances is 15 years.

重要注意事项

有毒有害物质或元素名称及含量表

根据中华人民共和国信息产业部『电器电子产品有害物质限制使用管理办法』，本产品《有毒有害物质或元素名称及含量表》如下。

部件名称	有毒有害物质或元素					
	铅 (Pb)	汞 (Hg)	镉 (Cd)	六价铬 (Cr (VI))	多溴联苯 (PBB)	多溴二苯醚 (PBDE)
SW-2005TL-5GE	x	○	○	○	○	○
SW-2005M-5GE						
SW-4005BL-5GE						
SW-4005M-5GE						

○:表示该有毒有害物质在该部件所有均质材料中的含量均在 GB/T 26572-2011规定的限量要求以下。
x:表示该有毒有害物质至少在该部件的某一均质材料中的含量超出 GB/T 26572-2011规定的限量要求。

环保使用期限



电子信息产品中含有的有毒有害物质或元素在正常使用的条件下不会发生外泄或突变、电子信息产品用户使用该电子信息产品不会对环境造成严重污染 或对其人身、财产造成严重损害的期限。

数字「15」为期限15年。

Usage Precautions

Notes on Cable Configurations

The presence of lighting equipment and television receivers nearby may result in video noise. In such cases, change the cable configurations or placement.

Notes on LAN Cable Connection

Secure the locking screws on the connector manually, and do not use a driver. Do not secure the screws too tightly. Doing so may wear down the screw threads on the camera. (Tightening torque: 0.147 Nm or less)

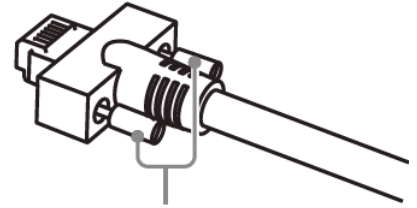

Caution: Secure manually. Do not secure too tightly.

Notes on Attaching the Lens



Technical Notes

How to Clean a Sensor

Avoiding Dust Particles

When attaching the lens to the camera, stray dust and other particles may adhere to the sensor surface and rear surface of the lens. Be careful of the following when attaching the lens.

- Work in a clean environment.
- Do not remove the caps from the camera and lens until immediately before you attach the lens.
- To prevent dust from adhering to surfaces, point the camera and lens downward and do not allow the lens surface to come into contact with your hands or other objects.
- Always use a blower brush to remove any dust that adheres.
- Never use your hands or cloth, blow with your mouth, or use other methods to remove dust.

Phenomena Specific to CMOS Image Sensors

The following phenomena are known to occur on cameras equipped with CMOS image sensors. These do not indicate malfunctions.

- **Aliasing:** When shooting straight lines, stripes, and similar patterns, vertical aliasing (zigzag distortion) may appear on the monitor.
- **Blooming:** When strong light enters the camera, some pixels on the CMOS image sensor may receive much more light than they are designed to hold, causing the accumulated signal charge to overflow into surrounding pixels. This “blooming” phenomenon can be seen in the image but does not affect the operation of the camera.
- **Fixed pattern noise:** When shooting dark objects in high-temperature conditions, fixed pattern noise may occur throughout the entire video monitor screen.
- **Defective pixels:** Defective pixels (white and black pixels) of the CMOS image sensor are minimized at the factory according to shipping standards. However, as this phenomenon can be affected by the ambient temperature, camera settings (e.g., high sensitivity and long exposure), and other factors, be sure to operate within the camera’s specified operating environment.

Notes on Exportation

When exporting this product, please follow the export regulations of your country or region.

Features

This camera is a linescan camera using TrilinearBilinear (color) and Monochrome CMOS line sensors. It has a small (44mm × 44mm × 64mm), lightweight design (186g for the color model; 185g for the monochrome model) with a 5 Gigabit interface.

Model Name	Image Sensor	Effective Pixels	Pixel Size	Max Line Rate
SW-2005TL-5GE	Trilinear (RGB)	2048 x 3	7.0µm x 7.0µm	44kHz
SW-2005M-5GE	Mono	2048x 1	7.0µm x 7.0µm	172kHz
SW-4005BL-5GE	Bilinear (RB-G)	4096 x 2	3.5µm x 3.5µm	42kHz
SW-4005M-5GE	Mono	4096 x 1	3.5µm x 3.5µm	84kHz

Features Overview

- Interface: 5GBASE-T interface (5 gigabits / second)
- Supports direct encoder connection to camera
- Wide variety of trigger options
- Provides all the features a line scan camera needs: PRNU, DSNU, Spatial Compensations*, White Balance*, Shading Correction, Binning, LUT, Color Space Conversion*

Notes:

- *Color model only
- For more information on the functions supported by this camera, see the [Main Functions](#) chapter.

- Excellent shock and vibration resistance
- Support the PoE function
- C-mount lens mount

Package Contents, Accessories

- Camera (1)
- Sensor Protection Cap (1)
- Dear Customer Sheet (1)

Optional Accessories (Sold Separately)

- AC Adapter

Parts Identification

Note: See "[Dimensions](#)" for external view of the entire camera.

Lens Mount (C-Mount)

Mount a C-mount lens here.

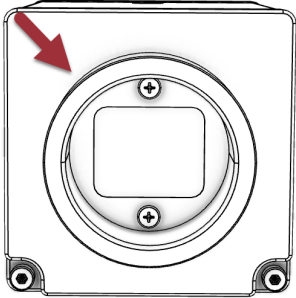

- Back flange distance: 17.526mm
- Thread Pitch: 0.79375mm

Note: Before mounting a lens, be sure to refer to [① Lens](#) and confirm the precautions for attaching a lens and the supported lens types.

Connectors

This section displays the pin assignments for each connector.

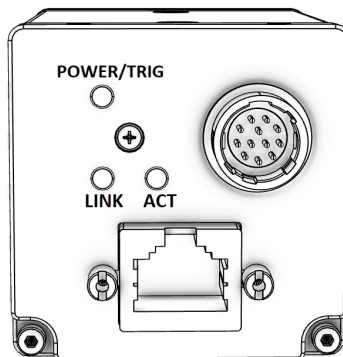

DC IN/TRIG Connector (12-Pin Round)

Related Setting Items: [DigitalIOControl](#)

Connect the cable for a power supply or for DC IN / trigger IN here.

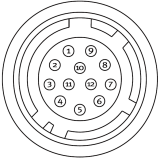
 <p>PN: HR10A-10R-12PB (71)</p>	Pin No.	Input/Output	Signal	Description
	1		GND	
	2	Power In	DC In	DC 10.8 ~ 26.4V
	3		GND	
	4	In	TTL In 4	Line 14
	5	In	Opto In 1 -	Line 5
	6	In	Opto In 1 +	
	7	Out	TTL Out 4	Line 12
	8		NC	
	9	Out	TTL Out 1	Line 1
	10	In	TTL In 1	Line 4
	11	Power In	DC In	DC 10.8 ~ 26.4V
	12		GND	

Note: The pin assignment of this camera is different from other JAI cameras.

TTL Signal Specification

TTL out signal specification (Typ.)	Output voltage: Low 0.0V, High 5.0V
TTL in signal specification (Typ.)	Input voltage: Low 0.0 ~ 0.7V, High 2.0 ~ 5.5V

RJ-45 Connector

Connect a Gigabit Ethernet compatible LAN cable (Category 5e or higher, Category 6 recommended) here.

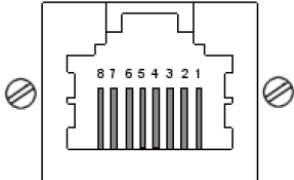

	GigE Vision Interface								
	Pin	8	7	6	5	4	3	2	1
	Signal	TRD- (3)	TRD+ (3)	TRD- (1)	TRD- (2)	TRD+ (2)	TRD+ (1)	TRD- (0)	TRD+ (0)

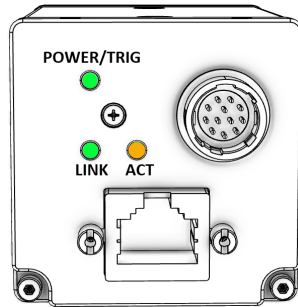
LEDs





The table below shows the LED light and camera status.



POWER TRIG

Light		Status
	Lit amber	Camera initializing.
	Lit green	Camera in operation.
	Blinking green	During operation in trigger mode, trigger signals are being input. Note: The blinking interval is not related to the actual input interval of the external trigger.

ACT

Light		Status
	Off	Communication is not active.
	Blinking amber	Communication is active.

LINK

Light		Status
	Off	The network link is not established (or is in progress).
	Blinking green (slow)	1000BASE-T link is established. (Interval 1sec)
	Blinking green (fast)	2.5GBASE-T or 5GBASE-T link is established. (Interval 200ms)

Mounting Holes

Use these holes to mount the camera directly to a structural system.

Location	Available Mounting Holes
Top	M3, Depth 3mm x 4
Bottom	M3, Depth 3mm x 4

Note: Refer to "[Dimensions](#)" for the location of the mounting holes.

Recommended External Input Circuit Diagram

Reference Example

Caution: Check the recommended external input circuit diagram (reference example) and connect correctly.

Note: Parts may be replaced with equivalent products.

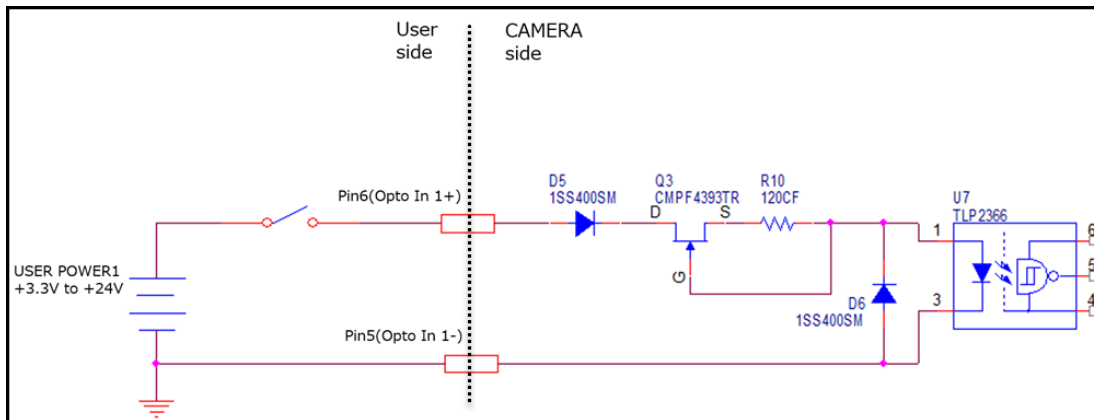

Preparation

Read this section to learn how the camera connects to devices and accessories. The preparation process is described below.

1	<p><u>Step 1: Install the Software (First Time Only)</u></p> <p>Install the software for configuring and controlling the camera (eBUS SDK for JAI) on the computer.</p>
2	<p><u>Step 2: Connect Devices</u></p> <p>Connect the lens, cables, AC adapter, computer, and other devices.</p>
3	<p><u>Step 3: Verify Camera Operation</u></p> <p>Verify whether the camera is turned on and ready for use.</p>
4	<p><u>Step 4: Verify the Connection between the Camera and PC</u></p> <p>Verify whether the camera is properly recognized via Control Tool.</p>
5	<p><u>Step 5: Configure Trigger, Exposure, and Line Rate Settings</u></p> <p>Refer to the setting examples to configure the trigger, exposure, and line rate settings.</p>
6	<p><u>Step 6: Adjust the Image Quality</u></p> <p>Refer to the procedures for adjusting the image quality.</p>
7	<p><u>Step 7: Save the Settings</u></p> <p>Save the current setting configurations in user memory.</p>

Step 1: Install the Software (First Time Only)

When using the camera for the first time, install the software for configuring and controlling the camera (eBUS SDK for JAI) on the computer.

Notes:

- When you install eBUS SDK for JAI, eBUS Player for JAI will also be installed.
- For the operating system (OS) requirements for eBUS SDK for JAI, see the JAI Camera Software page (<https://www.jai.com/support-software/jai-software>) or eBUS Player User Guide.

1. Download the eBUS SDK for JAI from the JAI website (<https://www.jai.com/support-software/jai-software>).
2. Install eBUS SDK for JAI on the computer.

Step 2: Connect Devices

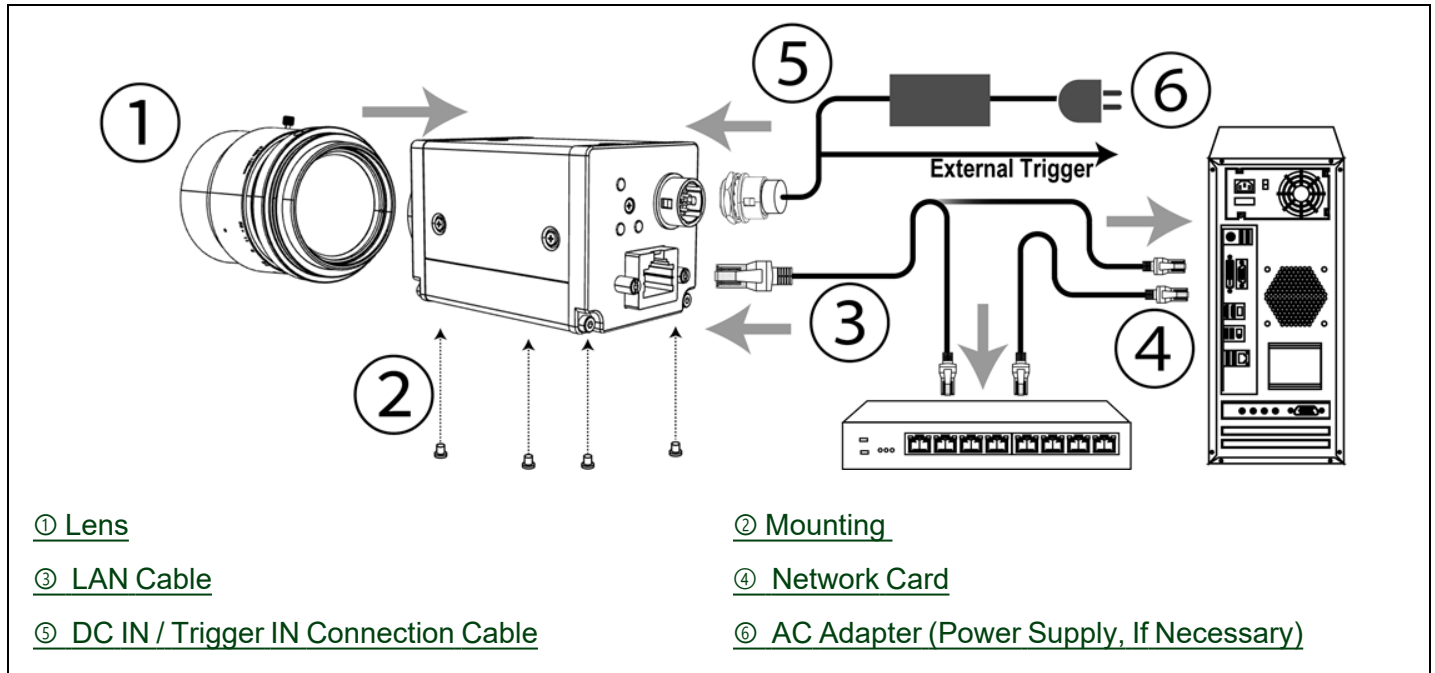

① Lens

C-mount lenses with lens mount protrusions of 9 mm or less can be attached.

- Back flange distance: 17.526mm
- Thread Pitch: 0.79375mm

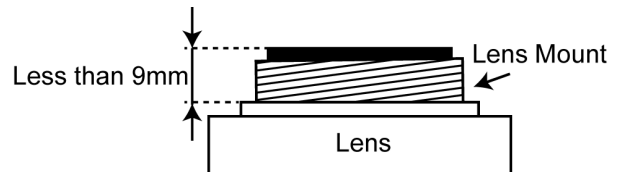

Cautions:

- The maximum performance of the camera may not be realized depending on the lens.
- Attaching a lens with a mount protrusion of 9 mm or longer may damage the lens or camera.

Note: The following formula can be used to estimate the focal length: **Focal length = $WD / (1 + W/w)$**

- WD: Working distance (distance between lens and object)
- W: Width of object
- w: Width of sensor

② Mounting

When mounting the camera directly to a device, use screws that match the mounting holes on the camera. For more information on the mounting holes, see "[Mounting Holes](#)".

Caution: For heavy lenses, be sure to support the lens itself. Do not use configurations in which its weight is supported by the camera.

③ LAN Cable

Connect a LAN cable to the RJ-45 connector.

Caution: See the [Notes on LAN Cable Connection](#) topic as well.

The camera supports the following Ethernet standards: 1000BASE-T, 2.5GBASE-T, 5GBASE-T.

- Use a LAN cable that is Category 5e or higher (Category 6 recommended).
- When supplying power via PoE, use a UTP Ethernet cable and connect to a PoE-compatible switching hub or a PoE-compatible network card.

Power Supply	Supported Ethernet Cable
PoE	UTP
12-pin	UTP or STP

Note: JAI does not recommend using a PoE injector. If a PoE injector is used, the camera may not be able to transmit images properly.

- Refer to the specifications of the cable for details on its bend radius.

LAN cable types, Ethernet standards, and maximum cable lengths are listed in the table below.

	Cat5e	Cat6 / Cat6e	Cat6A	Cat7
1000Base-T	100m	100m	100m	100m
2.5GBase-T	100m	100m	100m	100m
5GBase-T	100m	100m	100m	100m

④ Network Card

Install this on the computer that will be used to configure and operate the camera. As the camera supports PoE, you can also use PoE-compatible network cards. Refer to the instruction manual of the network card and configure settings on the computer as necessary.

⑤ DC IN / Trigger IN Connection Cable

Performs external I/O such as power supply and trigger input.

⑥ AC Adapter (Power Supply, If Necessary)

Connect the AC adapter and the round connector of the connection cable to the DC IN / trigger IN connector on the camera.

Step 3: Verify Camera Operation

When power is supplied to the camera while the necessary equipment is connected, the POWER/TRIG LED at the rear of the camera lights amber, and initialization of the camera starts. When initialization is complete, the POWER/TRIG LED lights green.

Verify whether power is being supplied to the camera by checking the rear LED. When properly turned on, the power LED is lit green.

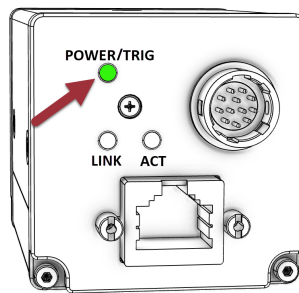

Note: For details on how to read the LEDs, see "[LEDs](#)".

Step 4: Verify the Connection between the Camera and PC

Verify whether the camera is properly recognized eBUS Player for JAI.

1. Launch eBUS Player for JAI.



eBUS Player for JAI startup screen appears.

2. Click the **Select / Connect** button.

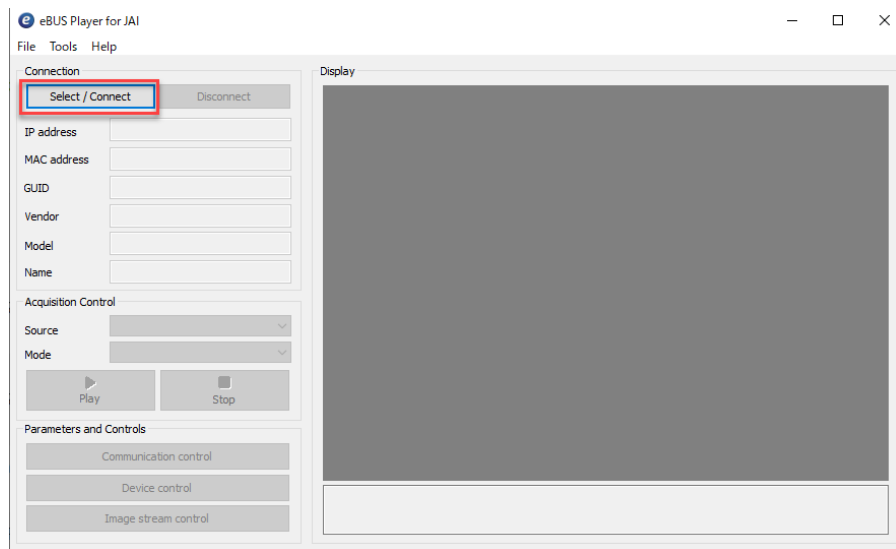

3. The connected camera is listed. Please select one camera and click **OK**.

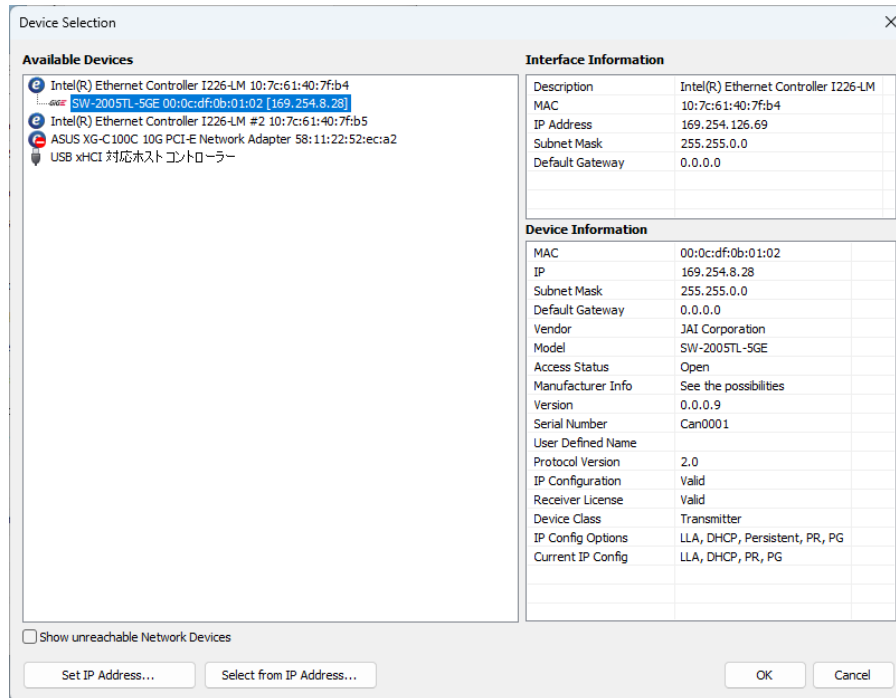

4. Check that the settings of the selected camera are displayed.

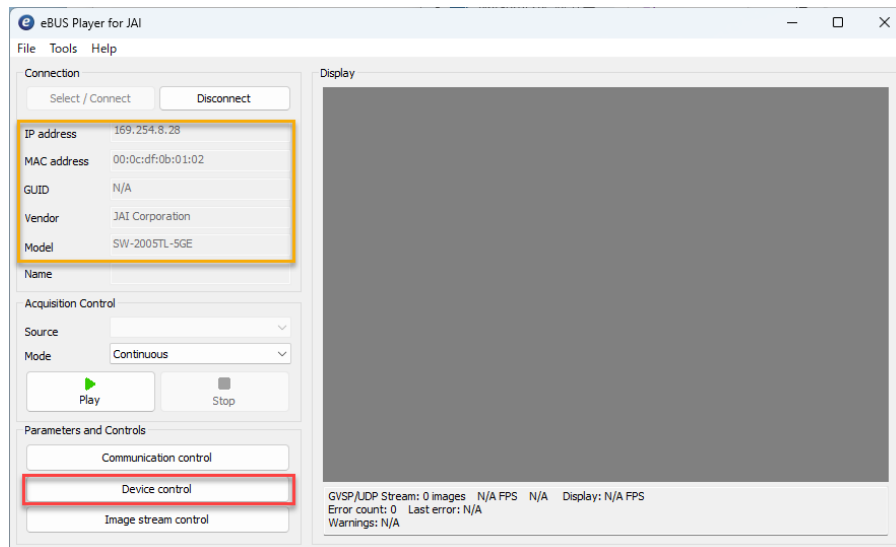

5. Click the **Device control** button. The DeviceControl window will be displayed. In this window, you can adjust various settings of the camera.

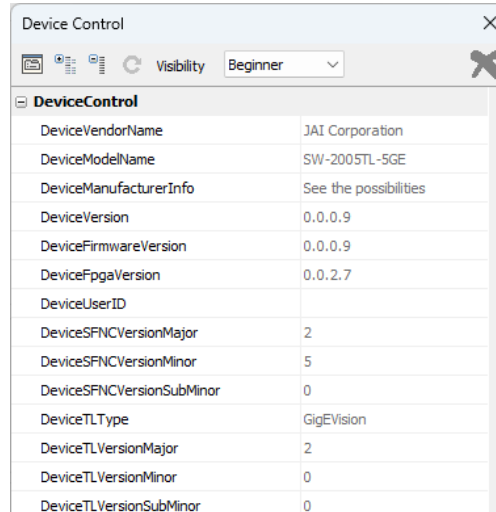

6. This completes the procedure for verifying whether the camera is properly recognized and whether control and settings configuration are possible.

Step 5: Configure Trigger, Exposure, and Line Rate Settings

Related Setting Items: [AcquisitionControl](#)

This section describes five scenarios for controlling the trigger, exposure, and line rate.

Note: This section is intended to explain the basic relationship between the trigger, exposure, and line rate. For the detailed timings, see "[Timing Chart](#)".

Trigger	Exposure	Setting Example
On	Timed	Control via External Triggers with the Specified Exposure Time
	TriggerWidth	Control via External Triggers with Exposure Time Controlled by the Pulse Width of the Trigger Input Signal
	Off	Control via External Triggers without Specifying the Exposure Time
Off	Timed	Control without External Triggers with the Specified Exposure Time
	Off	Control without External Triggers without Specifying the Exposure Time

Control via External Triggers with the Specified Exposure Time

In the example below, **TriggerSelector** is set to **LineStart**.

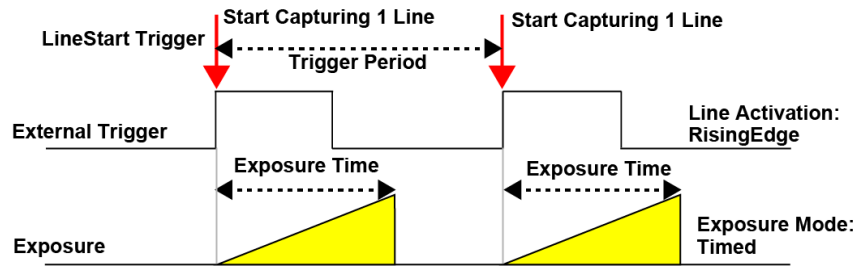

Notes:

- When using external triggers, the line rate is determined by the trigger period.
- The ExposureTime value cannot be longer than the trigger period.
- See "[ExposureMode = Timed](#)" for detailed timings.

Item	Setting
Trigger Mode	On
Trigger Selector	Line Start
Trigger Source	Any
Trigger Activation	RisingEdge (rising edge of input signal) or FallingEdge (falling edge of input signal)
Exposure Mode	Timed (control via exposure time)
Exposure Time	Varies depending on settings.

Control via External Triggers without Specifying the ExposureTime

In the example below, **TriggerSelector** is set to **LineStart**.

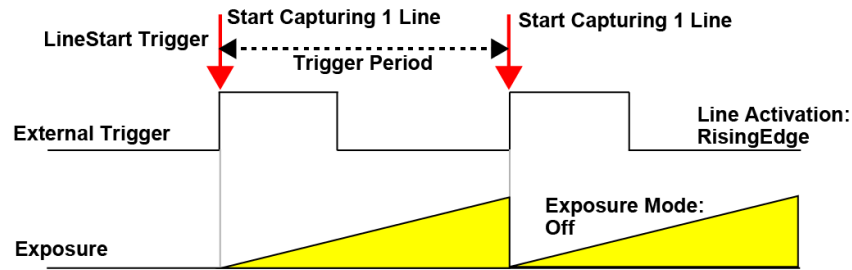

Notes:

- When using external triggers, the line rate is determined by the trigger period.
- The exposure is performed with an exposure time calculated from $1 / (\text{line rate})$.
- See "[ExposureMode = Off](#)" for detailed timings.

Item	Setting
Trigger Mode	On
Trigger Selector	Line Start
Trigger Source	Any
Trigger Activation	RisingEdge (rising edge of input signal) or FallingEdge (falling edge of input signal)
Exposure Mode	Off

Control via External Triggers with Exposure Time Controlled by the Pulse Width of the Trigger Input Signal

In the example below, **TriggerSelector** is set to **LineStart**.

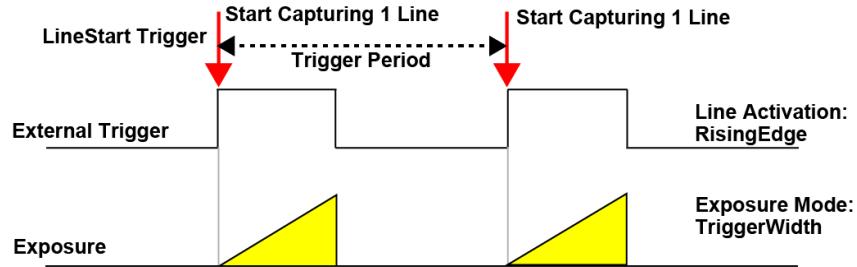

Notes:

- When using external triggers, the line rate is determined by the trigger period.
- See "[ExposureMode = TriggerWidth](#)" for detailed timings.

Item	Setting
Trigger Mode	On
Trigger Selector	Line Start
Trigger Source	Any
Trigger Activation	LevelHigh (high-level duration) or LevelLow (low-level duration)
Exposure Mode	TriggerWidth (control via trigger width)

Control without External Triggers with the Specified Exposure Time

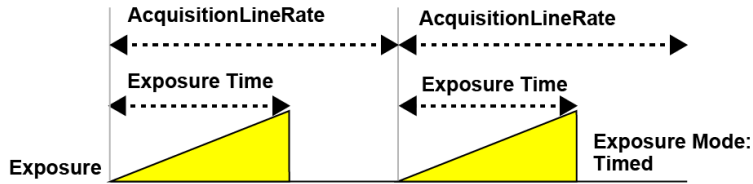

Notes:

- ExposureTime can be set up to 1 line cycle to match the speed of the object or to lengthen the accumulation time to increase sensitivity.
- The ExposureTime value cannot be longer than the line period.

Item	Setting
Trigger Mode	Off
Exposure Mode	Timed (control via exposure time)
Exposure Time	Varies depending on settings.
Acquisition Line Rate	The maximum value varies depending on PixelFormat, ROI, Link Speed, etc.

Control without External Triggers without Specifying the Exposure Time

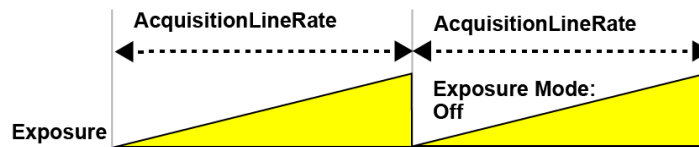

Notes:

- The line rate can be set up to 1 line cycle to match the speed of the object or to lengthen the accumulation time to increase sensitivity.
- The exposure is performed with an exposure time calculated from $1 / (\text{line rate})$.

Item	Setting
Trigger Mode	Off
Exposure Mode	Off
Acquisition Line Rate	The maximum value varies depending on PixelFormat, ROI, Link Speed, etc.

Step 6: Adjust the Image Quality

Use the following steps to adjust the image quality of this camera.

1. [DSNU Correction \(Pixel Black Correct\)](#)
2. [PRNU Correction \(Pixel Gain Correct\)](#)
3. [Adjust the Gain](#)
4. [Adjust the White Balance](#) (Color model only)
5. [Adjust the Black Level](#)

DSNU Correction (Pixel Black Correct)

Related Setting Items: [Correction](#)

DSNU (dark signal non-uniformity) is a variation between pixels in the dark areas generated by the sensor. If the line rate is slowed or a long exposure time is set, the dark current in the sensor may change and the state of the DSNU may change.



How to Configure

1. Place the sensor protection cap on the camera.
2. Start image acquisitions with AcquisitionStart [[AcquisitionControl](#)].
3. Specify the user area (User1 ~ User3) to save the black level correction value with **PixelBlackCorrectionMode**([Correction](#)).

Note: Default contains the correction data that was set at the factory.

4. Execute **CalibratePixelBlackCorrection**. Black level correction data is automatically generated and saved in the user area specified in PixelBlackCorrectionMode.
5. You can check the execution result of black level correction on **PixelBlackCalibrationResult**.

Result	Description
Succeeded	The correction has been successfully completed. The correction data has been saved to the user area specified in PixelBlackCorrection.

Result	Description
Error1 - Image was too bright	Correction failed. The image was too bright.
Error2 - Image was too dark	Correction failed. The image was too dark.
Error3 - Could not calibrated	Could not perform the correction because the camera is in one of the following status: <ul style="list-style-type: none"> • The image is not being output. • TestPattern[ImageFormatControl] is set to anything other than Off. • PixelBlackCorrectionMode is set to Off or Default.

PRNU Correction (Pixel Gain Correct)

Related Setting Items: [Correction](#)

PRNU (photo response non-uniformity) is a variation between pixels generated by the sensor under bright conditions. If the line rate is slowed or a long exposure time is set, the dark current in the sensor may change and the state of the PRNU may change.



PRNU Correction Modes (PixelGainCorrectionMode)

This camera supports the following PRNU correction modes. The difference is the area in which PRNU is performed. In all modes, if the image to be corrected is too bright or too dark, the camera performs the correction as close as possible to the target level (= best effort correction).

PixelGainCorrectionMode	Area to Calculate Correction Data	Area to Apply Correction
User1, User2, User3	Entire area (full ROI)	Entire area (full ROI)
SelectedROI	Area specified by the ROI settings	Area specified by the ROI settings

Note: For details on ROI, see "[ROI \(Regional Scanning Function\)](#)".

How to Execute

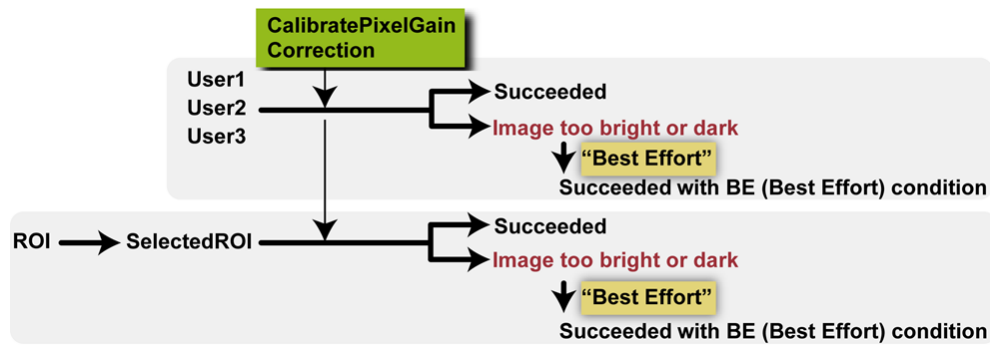

Notes:

- The video level should be between 70% and 90% of the saturation level. The sensor must be uniformly illuminated. If a lens is attached to the camera, it must be defocused.
- PRNU correction is performed under the condition that the image is flat with or without a lens attached. However, if there is shading due to a lens, light sources, etc., correction is performed to flatten the image including the effects of such shading.
- The subject should be a white, flat surface (such as a sheet of white paper).

1. If you perform PRNU only on the user-specified ROI, configure the **Width** and **OffsetX** values [[ImageFormatControl](#)].
2. Specify the setting (User1, User2, User3, or SelectedROI) to save the gain correction value in **PixelGainCorrectionMode** ([Correction](#)). For detailed information on each correction setting, see the "PRNU Correction Modes (PixelGainCorrectionMode)" section.

Note: Default contains the correction data that was set at the factory.

3. Execute **CalibratePixelGainCorrection** and correct the image. Gain correction data is automatically generated and saved in the area specified in **PixelGainCorrectionMode**. Then, the calibration result "Succeeded" is displayed in **PixelGainCalibrationResult**.
4. If the image is too bright or too dark, the camera makes the correction as close as possible to the target level ("Best Effort" correction), and displays the following result in **PixelGainCalibrationResult**.

The table below shows a list of the calibration result:

Result	PixelGain CorrectionMode	Description
Idle	Any	Correction has not been performed.
Succeeded	User1, User2, or User3	Correction was completed successfully. The correction data calculated from the full ROI has been applied to the entire area and saved in the user area specified in PixelGainCorrectionMode.
	SelectedROI	Correction was completed successfully. The correction data calculated from the specified ROI was applied to the ROI are and saved in SelectedROI.
Succeeded with BE condition	User1, User2, or User3	Correction was performed as close as possible to the target level in the entire area because the brightness of the entire area was outside the range for which normal correction can be performed. The correction data has been saved in the user area specified in PixelGainCorrectionMode.
	SelectedROI	Correction was performed as close as possible to the target level in the area specified by the ROI because the brightness of the specified area was outside the range for which normal correction can be performed. The correction data has been saved SelectedROI.
Error3 - Could not calibrated	Any	Could not perform the correction due to one of the following reasons: <ul style="list-style-type: none"> • The image is not being output. • TestPattern[ImageFormatControl] is set to anything other than Off. • PixelGainCorrectionMode is set to Off or Default.

Adjust the Gain

Related Setting Items: [AnalogControl](#)

Note: For details on gain control, see “[Gain Control](#)” in the Main Functions chapter.

Manual Adjustment

Monochrome Model:

1. If you want to disable the camera's internal fixed gain (= InGain) and only enable the user-set gain, set **InGainBypassMode** to **On** (default = Off).
2. Configure the Gain value (DigitalAll) in **Gain**.

Color Model: Two digital gain control modes are available: a mode in which the master gain is adjusted and fine adjustments are made for R and B (Master Mode), and a mode in which the gain can be adjusted for each RGB separately (Individual Mode).

- **MasterMode:**

1. Set **IndividualMode** to **Off**.
2. Select the DigitalGain (DigitalAll, DigitalRed, DigitalBlue) you want to configure from **GainSelector**.
3. Configure the Gain value in **Gain**.

- **IndividualMode:**

1. Set **IndividualMode** to **On**.
2. If you want to disable the camera's internal fixed gain (= InGain) and only enable the user-set gain, set **InGainBypassMode** to **On** (default = Off).
3. Select the DigitalGain (DigitalRed, DigitalGreen, DigitalBlue) you want to configure from **GainSelector**.
4. Configure the Gain value in **Gain**.

Automatic Adjustment

This camera can automatically adjust the gain. However, for color models, **IndividualGainMode** must be set to **Off** to use the automatic gain adjustment function.

1. Color model only: Set **IndividualMode** to **Off**.
2. If necessary, use **GainAutoWidth** and **GainAutoOffset** to configure the Gain adjustment area.
3. Configure **AGCReference** to set the convergence level.
4. Set **GainAuto** to **Once**.
5. The Gain value is automatically adjusted. After the adjustment, GainAuto returns to Off.
6. The adjustment status can be checked in **AGCOnceStatus**.

Result	Description
Idle	Adjustment is not being performed.
Processing	Adjustment is being performed.
Succeeded	Adjustment was completed successfully. After the adjustment, GainAuto returns to Off.
Error3 - Timeout	Adjustment failed. Adjustment was repeated for 10 seconds without success.
Error4 - could not processing	Could not perform the adjustment due to one of the following reasons: <ul style="list-style-type: none"> • The image is not being output. • TestPattern[ImageFormatControl] is set to anything other than Off.

Adjust the White Balance

Related Setting Items: [AnalogControl](#)

Adjust the white balance using the automatic adjustment function.

Note: This function is only supported on the color model.

Automatic Adjustment Modes

This camera provides the following two modes for automatic white balance adjustment.

BalanceWhiteAuto	Adjustment Area	When Normal Correction Cannot Be Performed
Once	Area specified by BalanceWhiteAutoWidth and BalanceWhiteAutoOffsetX	Adjustment is aborted
OnceUserAreaBE	Entire Area	Adjust the white balance as close as possible to the target level (Best Effort calibration).

Note: "OnceUserAreaBe" is a "Best Effort" calibration method. The white balance may not be perfect when this option is selected due to extremely unbalanced illumination of the target object. For example, when the lighting does not emit any red photons, a fully balanced image output cannot be achieved, but green and blue will be balanced after the adjustment.

How to Configure Automatic White Balance Adjustment



1. Place a white/gray White Balance target in front of the camera, at the same position as the inspected object. Ensure that the White Balance target fills the whole image or ROI used (if UserArea is used).
2. If necessary, use **BalanceWhiteAutoWidth** and **BalanceWhiteAutoOffsetX** to configure the white balance adjustment area.
3. Set **BalanceWhiteAuto** to **Once** or **OnceUserAreaBe**. For more information, see "Automatic Adjustment Modes".

Notes:

- When **BalanceWhiteAuto** is set to **Off**, the white balance cannot be adjusted automatically. Manually adjust the white balance using **Gain** [[AnalogControl](#)].
- When **IndividualGainMode** [[AnalogControl](#)] is set to **On**, **BalanceWhiteAuto** is forced to **Off**.
- The **BalanceWhiteAutoWidth** and **BalanceWhiteAutoOffsetX** settings apply only to the Once option. When OnceUserAreaBe is selected, the BalanceWhiteAutoWidth and BalanceWhiteAutoOffsetX settings are ignored.

4. The white balance is automatically adjusted. After the adjustment, "**Succeeded**" is displayed in **BalanceWhiteAutoResult**. Once the adjustment is completed, BalanceWhiteAuto returns to Off.
5. When normal correction cannot be performed, or if the white balance adjustment fails after 10 seconds of repeated attempts, the camera operates differently depending on the selected BalanceWhiteAuto setting.
 - **Once**: The adjustment attempt fails. An error message is displayed in BalanceWhiteAutoResult (for more information, see the "BalanceWhiteAutoResult" section below).
 - **OnceUserAreaBe**: The camera continues to adjust the whitebalance as close as possible to the target level until the timeout period is reached.

Once the adjustment is complete, "Succeeded with BE condition" is displayed in BalanceWhiteAutoResult.

Note: On this camera, the white balance can also be set to "Color Temperature" (**Preset5000K**, **Preset6500K**, **Preset7500K**). When using the Color Temperature option, **IndividualGainMode** [[AnalogControl](#)] must be set to **Off**.

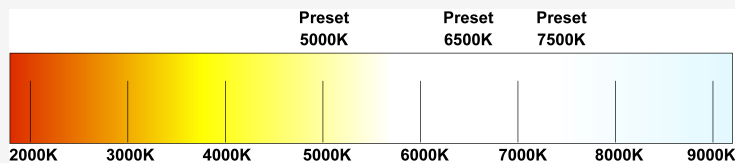

BalanceWhiteAutoResult

A list of calibration results when **BalanceWhiteAuto** is set to **Once** or **BalanceWhiteAuto** is shown below.

Result	BalanceWhiteAuto	Description
Idle	Any	Adjustment is not being performed.
Processing	Any	Adjustment is being performed.
Succeeded	Once	Adjustment was completed successfully to the area specified by BalanceWhiteAutoWidth and BalanceWhiteAutoOffsetX . After the adjustment, BalanceWhiteAuto returns to Off.
	OnceUserAreaBE	Adjustment was completed successfully for the entire area. After the adjustment, BalanceWhiteAuto returns to Off.
Succeeded with BE condition	OnceUserAreaBE	Adjusted the white balance as close as possible to the target level. Could not perform normal adjustment because the Red and/or Blue levels in the entire image were too high or too low compared to the Green level.
Error1 - G image was too bright	Once	Adjustment failed. The Green level in the area specified by BalanceWhiteAutoWidth and BalanceWhiteAutoOffsetX was too high compared to the Red or Blue level.
Error2 - G image was too dark	Once	Adjustment failed. The Green level in the area specified by BalanceWhiteAutoWidth and BalanceWhiteAutoOffsetX was too low compared to the Red or Blue level.
Error3 - Timeout	Once	Adjustment failed. Adjustment was repeated for 10 seconds without success.
Error4 - Target level was too high	Once	Adjustment failed. The target level was too high.
Error5 - Target level was too low.	Once	Adjustment failed. The target level was too low.

Adjust the Black Level

Related Setting Items: [AnalogControl](#)

1. Select the black level you want to configure in **BlackLevelSelector**.
 - Monochrome model: All (Master black) only
 - Color model: All (Master black), Red, Blue
2. Specify the adjustment value in **BlackLevel**.

Step 7: Save the Settings

Related Setting Items: [UserSetControl](#)

The configured setting values will be deleted when the camera is turned off. By saving current setting values to user memory, you can load and recall them whenever necessary. You can save up to three sets of user settings in the camera. (User Set1 to 3)

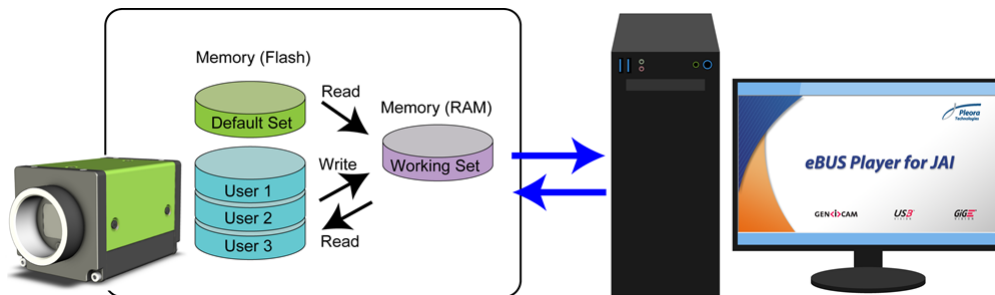

Note: Changes to settings are not saved to the computer (Control Tool).

To Save User Settings

1. Stop image acquisition.
2. Expand **UserSetControl** and select the save destination (UserSet1 to UserSet3) in UserSetSelector.

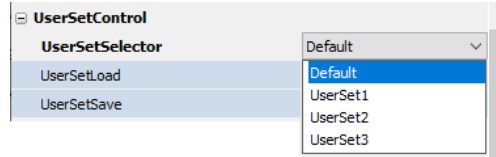

Note: The factory default setting values are stored in Default and cannot be overwritten.

Caution: Settings can only be saved when image acquisition on the camera is stopped.

3. Select **UserSetSave** and click the **UserSetSave** button.

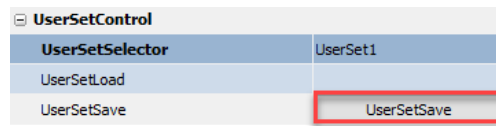

4. The current setting values are saved as user settings.

To Load User Settings

1. Stop image acquisition. User settings can only be loaded when image capture on the camera is stopped.
2. Select the settings to load (UserSet1 to UserSet3) in UserSetSelector.

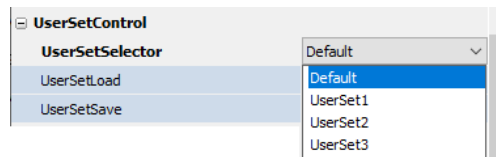

3. Select **UserSetLoad** and click the **UserSetLoad** button.

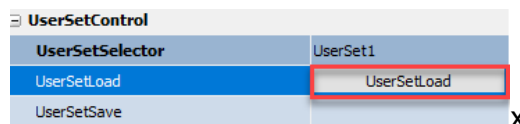

4. The selected user settings are loaded.

Note: When selecting **Default**, the factory settings are loaded.

Main Functions

This chapter describes the camera's main functions.

ROI (Regional Scanning Function)

Related Setting Items: [ImageFormatControl](#)

The ROI (region of interest) function allows you to output images by specifying the area to scan.

ROI Settings

Specify the area to scan by specifying the Width, Horizontal offset (OffsetX), Height (number of lines), and Vertical offset (OffsetY) values ([ImageFormatControl](#)).

Note: For the relationship between this function and the line rate, see "[Maximum Line Rates \(Approximate\)](#)".

The setting ranges for the ROI function's readable area based on the Binning setting (BinningHorizontal) are as follows.

	SW-2005 Models (WidthMax: 2048)		SW-4005 Models (WidthMax: 4096)	
	Binning = Off	Binning = On	Binning = Off	Binning = On
Width (pixels)	128 ~ (2048 - OffsetX), step 8	64 ~ (1024 - Offset X), step 8	128 ~ (4096 - OffsetX), step 8	64 ~ (2048 - Offset X), step 8
OffsetX (pixels)	0 ~ (2048 - Width), step 8	0 ~ (1024 - Width), step 8	0 ~ (4096 - Width), step 8	0 ~ (2048 - Width), step 8
Height (lines)	1 ~ (4096 - OffsetY)		1 ~ (4096 - OffsetY), step 1	
OffsetY (lines)	0 ~ (4096 - Height)		0 ~ (4096 - Height), step 1	

Notes:

- This camera does not support vertical binning.
- The BinningHorizontal setting does not affect the Height and OffsetY settings.
- This camera streams Width x Height data as 1 block.

ROI Examples (SW-2005 Model)

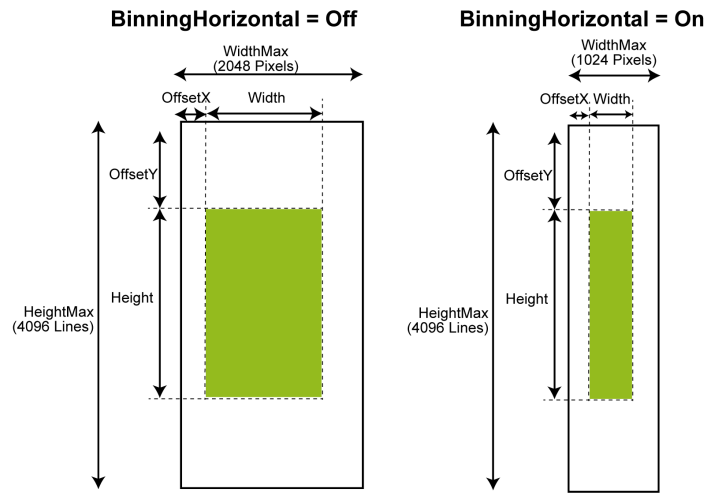

For example, when **Offset** is set to 8 and **OffsetY** is set to 5, the first readout pixel is the 9th pixel on line 6.

	1	2	3	4	5	6	7	8	9	10	11	12	13	14
1														
2														
3														
4														
5														
6														
7														

Binning Function

Related Setting Items: [ImageFormatControl](#)

The Binning function allows you to combine the signal values of clusters of adjacent pixels to create improved virtual pixels. Using this function results in images with higher sensitivity in Sum mode or reduced noise in Average mode.



This camera supports BinningHorizontal.

Binning Type	Process Method	Supported Mode
BinningHorizontal	Digital (FPGA)	Sum
		Average

Note: Refer to JAI's blog "[Using pixel binning to increase image quality under low light conditions](#)" on how to use the Binning function.

Pixel Size when Binning is On



	BinningHorizontal = 1 (Off)	BinningHorizontal = 2 (On)
		
SW-2005 Models	7 μm x 7 μm (WidthMax: 2048)	14 μm x 7 μm (WidthMax: 1024)
SW-4005 Models	3.5 μm x 3.5 μm (WidthMax: 4096)	7 μm x 3.5 μm (WidthMax: 2048)

Image Flip Function (ReverseX)

Related Setting Items: [ImageFormatControl](#)

You can output the image by inverting it horizontally with this function.



Notes:

- The **Width** and **OffsetX** settings are not affected by this function because the image is flipped after the image acquisition.
- SW-4005BL model: When **BiColorRGBG** pixel format is selected and **ReverseX** is set to On, the PixelFormat is changed to **BiColorBGRG**.

Pixel Format

Related Setting Items: [ImageFormatControl](#)

Selectable PixelFormat is as follows.

Model	PixelFormat
SW-2005TL-5GE	RGB8 (Default), RGB10V1Packed, RGB10p32, RGB12V1Packed
SW-4005BL-5GE	RGB8 (Default), RGB10V1Packed, RGB10p32, RGB12V1Packed, BiColorRGBG8*, BiColorRGBG10*, BiColorRGBG10p*, BiColorRGBG12*, BiColorRGBG12p*
SW-2005M-5GE SW-4005M-5GE	Mono8 (Default), Mono10, Mono12, Mono10Packed, Mono12Packed
*When ReverseX (ImageFormatControl) is set to On, the PixelFormat changes to BiColorBGRGxxx.	

Notes: The **BiColor** pixel formats are supported in the following eBUS SDK versions:

BiColor Pixel Format	Supported eBUS SDK Version
BiColorRGBG8, BiColorRGBG10, BiColorRGBG12	6.5.3 or later
BiColorRGBG10p, BiColorRGBG12p	6.5.4 or later

Pixel Alignment of the Sensor

The following is the pixel alignment of the sensor that is used on the camera.

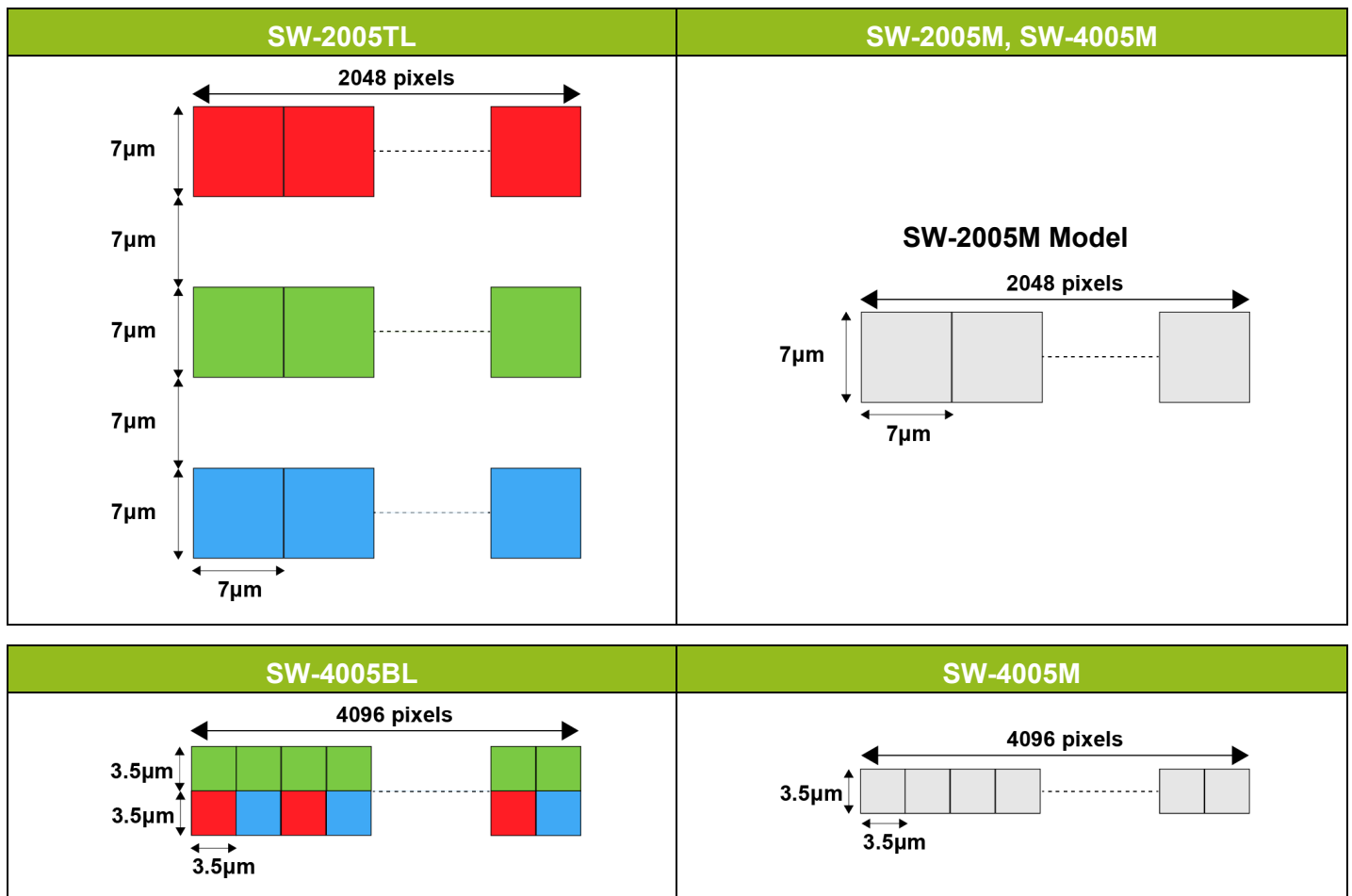

BiColorRGBG / BiColorBGRG Steam Data Alignment

The following is an illustration of the flow of the stream data output from the camera when the pixel format is BiColorRGBG or BiColorBGRG.

BiColorRGBG (ReverseX = Off)

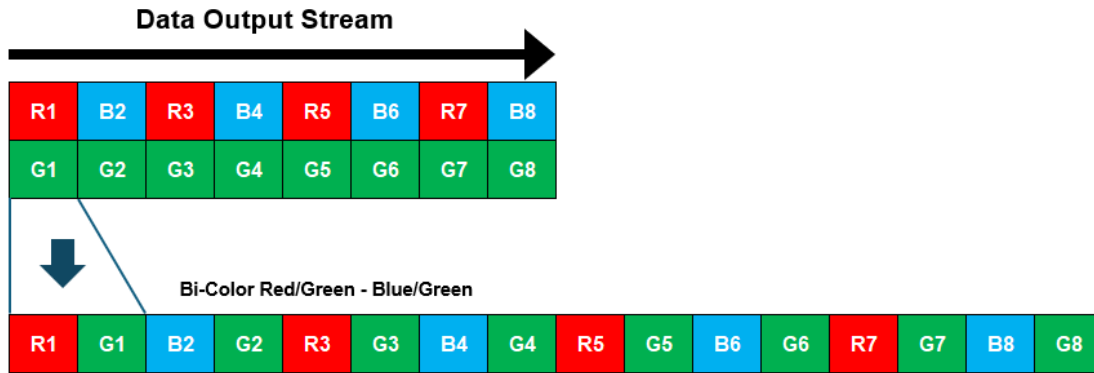

BiColorBGRG (ReverseX = On)

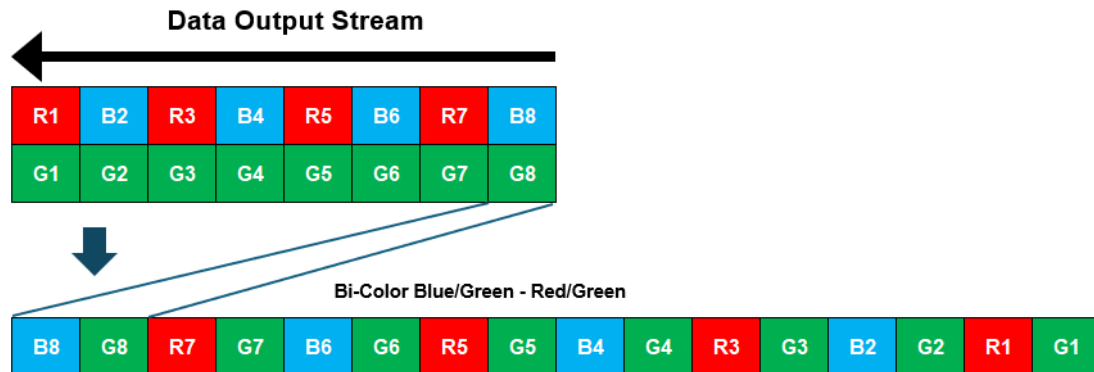

Bicolor Pixel Format Data Array

The data array of each BiColor pixel format is shown below.

BiColorRGBG8

0x021000A5 PFNC Bi-color Red/Green - Blue/Green 8-bit

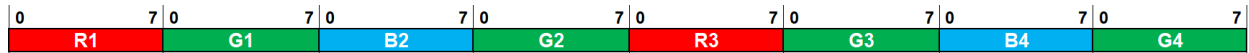

BiColorBGRG8 (ReverseX = On)

0x021000A6 PFNC Bi-color Blue/Green - Red/Green 8-bit

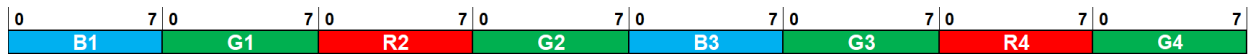

BiColorRGBG10

0x022000A7 PFNC Bi-color Red/Green - Blue/Green 10-bit unpacked

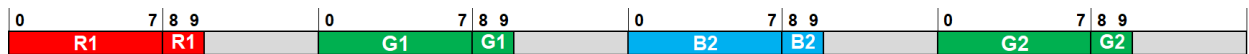

BiColorBGRG10 (ReverseX = On)

0x022000A9 PFNC Bi-color Blue/Green - Red/Green 10-bit unpacked

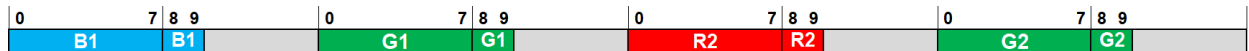

BiColorRGBG12

0x022000AB PFNC Bi-color Red/Green - Blue/Green 12-bit unpacked

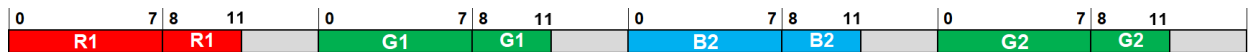

BiColorBGRG12 (ReverseX = On)

0x022000AD PFNC Bi-color Blue/Green - Red/Green 12-bit unpacked

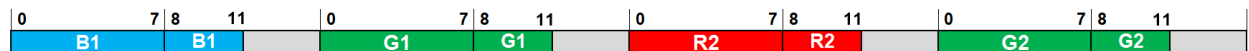

BiColorRGBG10p

0x021400A8 PFNC Bi-color Red/Green - Blue/Green 10-bit packed

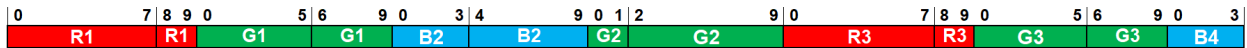

BiColorBGRG10p (ReverseX = On)

0x021400AA PFNC Bi-color Blue/Green - Red/Green 10-bit packed

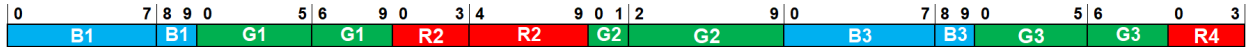

BiColorRGBG12p

0x021800AC PFNC Bi-color Red/Green - Blue/Green 12-bit packed

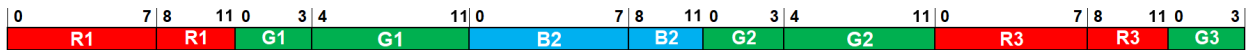

BiColorBGRG12p (ReverseX = On)

0x021800AE PFNC Bi-color Blue/Green - Red/Green 12-bit packed

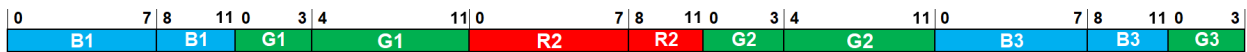

Acquisition Control

Related Setting Items: [AcquisitionControl](#)

Use the [AcquisitionControl](#) settings to perform operations and settings for image capture. This camera supports the following Acquisition modes.

AcquisitionMode	Description	
SingleFrame	When the AcquisitionStart command is executed, one frame of image is captured.	
MultiFrame	When the AcquisitionStart command is executed, the number of frames set in AcquisitionFrameCount are acquired as images.	
Continuous	When the AcquisitionStart command is executed, images will continue to be acquired until the AcquisitionStop command is executed.	

Change the Line Rate

When **TriggerMode** is set to **Off**, you can set the line rate using **AcquisitionLineRate**. This function can be used to match the scanning speed of the camera to the feeding speed of the object or to lengthen the accumulation time to increase sensitivity.

The minimum value that can be set is 66 Hz, and the maximum value varies depending on the settings. For more information on the maximum value, see "[Maximum Line Rates \(Approximate\)](#)".

Supported Operation Modes

Exposure Mode	TriggerMode	Example
Timed	Off	Control without External Triggers with the Specified Exposure Time
Off	Off	Control without External Triggers without Specifying the Exposure Time

Note: You can also save the setting, and have it applied whenever the power is subsequently turned on, but this requires additional operations. ([Step 7: Save the Settings](#))

Maximum Line Rates (Approximate)

Related Setting Items: [AcquisitionControl](#)

Below are the approximate maximum line rates at various settings.

Notes:

- The maximum line rates shown below are when Bandwidth = 5000Mbps, ExtendedIDMode = Off, SCPS = 7976 bytes, and NetworkThroughputSafetyMargin = 92.
- When BinningHorizontal ([ImageFormatControl](#)) = 2 (ON), the Width value after Binning applies.
- The frame rate can be calculated using the following formula: Frame Rate = Line Rate / Height
- This camera has a limitation when enabling Event function(s) other than AcquisitionStart / AcquisitionStop. See "[Event Control Function](#)" for more information.

SW-2005TL-5GE

Line rate 44kHz: Sensor limitation of this model.

Width	Max Line Rate		
	RGB8	RGB10V1Packed, RGB10p32	RGB12V1Packed
2048 (Full)	44kHz	44kHz	44kHz
1536 (3/4)	44kHz	44kHz	44kHz
1024 (1/2)	44kHz	44kHz	44kHz
512 (1/4)	44kHz	44kHz	44kHz

SW-2005M-5GE

Line rate 172kHz: Sensor limitation of this model.

Width	Max Line Rate		
	Mono8	Mono10, Mono12	Mono10 Packed, Mono12Packed
2048 (Full)	172kHz	130kHz	169kHz
1536 (3/4)	172kHz	169kHz	172kHz
1024 (1/2)	172kHz	172kHz	172kHz
512 (1/4)	172kHz	172kHz	172kHz

SW-4005BL-5GE

Line rate 42kHz: Sensor limitation of this model.

4Width	Max Line Rate					
	RGB8	RGB10V1Packed, RGB10p32	RGB12V1Packed	BiColorRGBG8	BiColorRGBG10, BiColorRGBG12	BiColorRGBG10p, BiColorRGBG12p
4096 (Full)	42kHz	32kHz	28kHz	42kHz	34kHz	42kHz
3072 (3/4)	42kHz	42kHz	40kHz	42kHz	42kHz	42kHz
2048 (1/2)	42kHz	42kHz	42kHz	42kHz	42kHz	42kHz
1024 (1/4)	42kHz	42kHz	42kHz	42kHz	42kHz	42kHz

SW-4005M-5GE

Line rate 84kHz: Sensor limitation of this model.

Width	Max Line Rate		
	Mono8	Mono10, Mono12	Mono10 Packed, Mono12Packed
4096 (Full)	84kHz	72kHz	84kHz
3072 (3/4)	84kHz	84kHz	84kHz
2048 (1/2)	84kHz	84kHz	84kHz
1024 (1/4)	84kHz	84kHz	84kHz

Trigger Control

Related Setting Items: [AcquisitionControl](#)

The camera allows the following controls to be performed via external trigger signals.

TriggerSelector	Description
AcquisitionStart	<p>Start image acquisition in response to the external trigger signal input.</p> <p>Note: You can set the number of lines between the trigger input and the time when image data is output to the host with the Image Output Delay setting.</p>
AcquisitionEnd	Stop image acquisition in response to the external trigger signal input.
LineStart	Acquire one line in response to the external trigger input. Select this option when Exposure control is performed by an external trigger.
FrameStart	<p>Acquire one frame in response to the external trigger signal input. Select this to perform exposure control using external triggers.</p> <p>Note: For more information, see "Frame Start Trigger" and "FrameStart Trigger and AcquisitionTransferStart Trigger".</p>
AcquisitionTransferStart	<p>Output acquired images at a specified timing in response to an external trigger signal input.</p> <p>Note: There is a limit to the number of image frames that can be stored internally. The approximate value can be calculated using the following formula.</p> $\text{MIN}(\text{ROUNDDOWN}(127\text{MB} \div \text{PayloadSize}) - 1, 1000)$ <p>For example, when Width = 2048, Height = 4096, and PixelFormat = RGB8, "4" frames can be stored in the camera.</p>

Notes:

- When TriggerMode is On, the camera first receives the AcquisitionStart command ([AcquisitionControl](#)), the Acquisition trigger signal, and then outputs images.
- The settings for exposure control and triggers are related to each other. Refer to "[Step 5: Configure Trigger, Exposure, and Line Rate Settings](#)" when configure the settings.

Image Output Delay

The ImageOutputDelay function allows you to set the number of lines between the trigger input and the time when image data is output to the host. This function is useful when you want to delay the time between receiving a trigger and outputting image data to the host, for example, when the object detection sensor and the line scan camera cannot be installed in the same location.

In the following example, an image of an object moving on a conveyor belt is acquired by a trigger signal from an encoder. The optical sensor and the image acquisition position of the line scan camera are 1 mm apart, and the conveyor speed is 0.1 mm per encoder cycle. In this case, the image data output is masked 10 lines after the optical sensor detects the object ($0.1 \text{ mm/edge} \times 10 \text{ lines} = 1 \text{ mm}$).

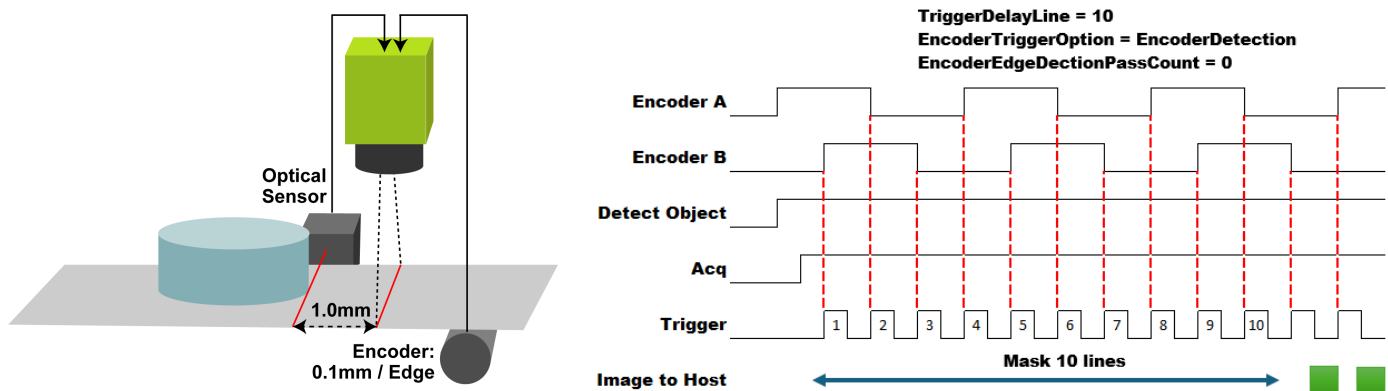

Notes:

- This function can be used not only with the encoder, but also when images are acquired using other external triggers (TriggerMode = On) or by the camera's internal trigger (TriggerMode = Off).
- When using an external trigger, set **TriggerSelector** to **AcquisitionStart**. If TriggerSelector is set to AcquisitionEnd or LineStart, this function is fixed to 0.
- For more information on the encoder, see "[Connecting Rotary Encoders](#)".

Frame Start Trigger

In this camera, Data Leader and Data Trailer are added to every frame. The number of lines per frame is set by Offset Y and Height of [ImageFormatControl](#).

Offset Y's setting range is 0 to 4095. The Height setting range is 1 to 4096.

One Frame of Image Data (Offset Y = 0)



One Frame of Image Data (Offset Y > 0)

Image Data for the number of lines specified by OffsetY will not be sent (empty block below).



When using Frame Start Trigger, after receiving Frame Start Trigger, skip the image data of the number of lines of Offset Y and send the data of Data Leader, image data, and Data Trailer. (Upon completion of data transmission for one frame, no data will be sent until the next Frame Start Trigger is received.)

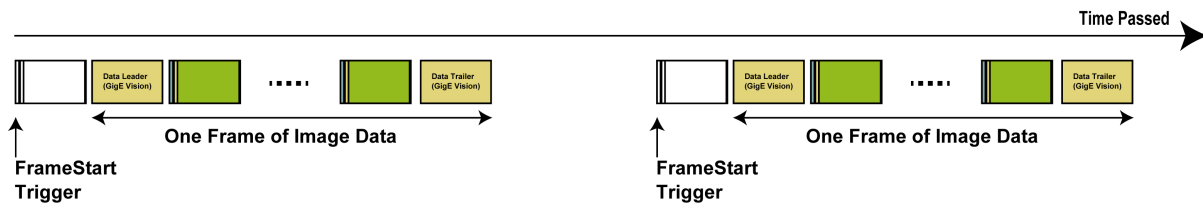

Caution: Chunk Data (first line of every frame only) is sent after Data Trailer.

FrameStart Trigger and AcquisitionTransferStart Trigger

On this camera, when **AcquisitionTransferStart** is **On**, the camera expects that the number of **AcquisitionTransferStart** trigger inputs is the same as the number of **FrameStart** trigger inputs. Otherwise, a GVSP error may occur.



For example, if the FrameStart trigger is issued 100 times but the AcquisitionTransferStart trigger is issued only once, the camera attempts to send the first frame, but a GVSP Error will be sent instead because the first frame is already discarded. The below shows an example of when the camera can hold up to 10 frames in the frame memory.

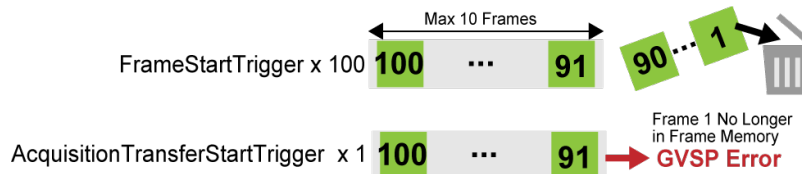

To output an image, the AcquisitionTransferStart trigger must be issued continuously until it reaches the number of frames in the frame memory. For example, if 10 frames remain in the frame memory, the AcquisitionTransferStart trigger must be issued 90 more times to output the image.

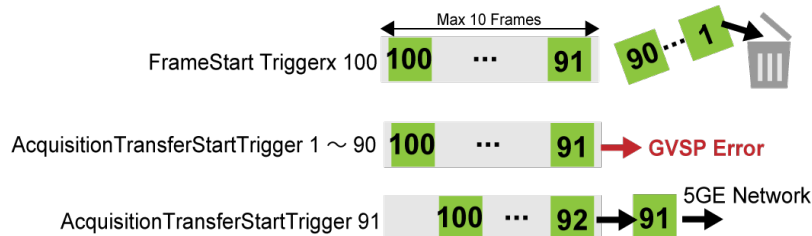

Exposure Mode

Related Setting Items: [AcquisitionControl](#)

The following exposure modes are available on the camera.

Exposure Mode	Description	Examples
Off	Exposure control is not performed (free-running operation).	Control via External Triggers without Specifying the ExposureTime
		Control without External Triggers without Specifying the Exposure Time
Timed	Mode in which control is performed using ExposureTime. Acquire images using an exposure time configured beforehand on an external trigger.	Control via External Triggers with the Specified Exposure Time
		Control without External Triggers with the Specified Exposure Time
Trigger Width	Mode in which control of the exposure time is performed using the pulse width of the trigger input signal. The exposure time will be the same as the pulse width of the trigger input signal. This allows long exposure.	Control via External Triggers with Exposure Time Controlled by the Pulse Width of the Trigger Input Signal

Note: When **ExposureMode** is set to **Timed** or **TriggerWidth**, the actual exposure time will consist of the image sensor's offset duration added to the ExposureTime setting configured on the camera or the Width of the trigger signal to the camera. For more information, see "[Actual Exposure Time](#)".

ExposureTimeMode (TL model only)

When **ExposureMode** is set to **Timed**, you can select the following Exposure Time Mode.

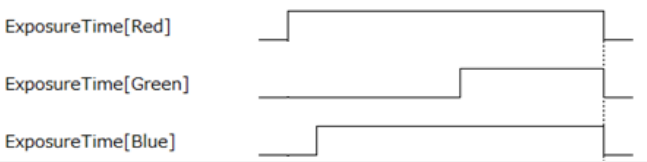
ExposureTimeMode	Description
Common (Default)	Set the common exposure time for Red, Green, and Blue (the RGB channels will have the same exposure time).
Individual	<p>Set the exposure times for Red, Green, and Blue individually. To set the exposure time individually for Red, set ExposureTimeSelector to Red, and configure the exposure time for Red in ExposureTime. Similarly, configure the exposure times individually for Green and Blue.</p> <p>Note: The actual exposure time starts with the channel with the longest exposure time and ends with the channel with the shortest exposure time, so that the exposures end at the same time (see image below).</p> 

Note: When **ExposureMode** is set other than **Timed**, **ExposureTimeMode** is fixed to **Common**.

■ ExposureModeOption

Specifies whether to prioritize exposure time (PrioritizeExposureTime) or line rate (PrioritizeLineRate) when controlling line rate and exposure.

- **PrioritizeExposureTime**(Default): This option does not allow you to set a line rate shorter than the configured ExposureTime.
 - The maximum AcquisitionLineRate value is limited by the line rate value calculated from the current ExposureTime setting.
 - If you want a faster AcquisitionLineRate value, you must first decrease the ExposureTime value.

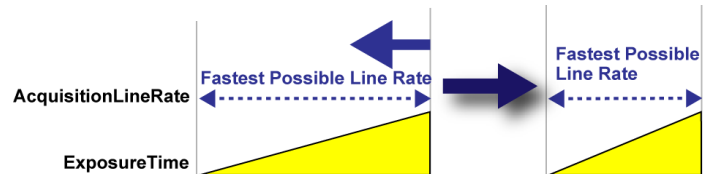

- **PrioritizeLineRate**: This option gives the line rate priority over the configured ExposureTime.
 - When AcquisitionLineRate becomes faster, if the current ExposureTime value (1) is greater than the ExposureTime value calculated from the faster AcquisitionLineRate setting (2), the ExposureTime value will be overwritten with the value (2).

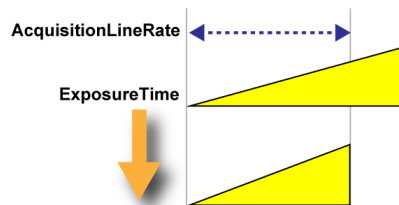

- If you want to increase the ExposureTime value further, you must first set AcquisitionLineRate to a slower value.

Actual Exposure Time

The actual exposure time will consist of the image sensor's offset duration added to the ExposureTime setting (when ExposureMode = Timed) or the Width of the trigger signal to the camera (when ExposureMode = TriggerWidth). See the table below for the exposure offset time for each camera model.

Camera Model	Exposure Offset Time
SW-2005TL-5GE	3.11 μ s
SW-2005M-5GE	1.54 μ s
SW-4005BL-5GE	3.11 μ s
SW-4005M-5GE	2.06 μ s

The minimum ExposureTime setting is 0.11 μ s (step 0.01), and the maximum Exposure setting depends on other settings (see **Exposure Mode** on "[Specifications](#)").

Note: On this camera, when TriggerMode is set to On, there is a delay time between the external trigger input and the start of the exposure. For more information, see "[Delay Time from Trigger Input to Start of Exposure](#)".

ExposureMode = Timed

When **ExposureTime** is set to 1 μ s, the actual exposure time will be as follows.

Camera Model	ExposureTime Setting	Actual Exposure Time (ExposureTime + Offset)
SW-2005TL-5GE	1 μ s	4.11 μ s (= 1 μ s + 3.11 μ s)
SW-2005M-5GE	1 μ s	2.54 μ s (= 1 μ s + 1.54 μ s)
SW-4005BL-5GE	1 μ s	4.11 μ s (= 1 μ s + 3.11 μ s)
SW-4005M-5GE	1 μ s	3.06 μ s (= 1 μ s + 2.06 μ s)

ExposureMode = TriggerWidth

The actual exposure time will consist of the image sensor's offset duration added to the Width of the trigger signal to the camera.

Camera Model	Exposure Time Needed	Width of the Trigger Signal to the Camera
SW-2005TL-5GE	4.11 μ s	1 μ s (= 4.11 - 3.11 μ s)
SW-2005M-5GE	2.54 μ s	1 μ s (= 2.54 - 1.54 μ s)
SW-4005BL-5GE	4.11 μ s	1 μ s (= 4.11 - 3.11 μ s)
SW-4005M-5GE	3.06 μ s	1 μ s (= 3.06 - 2.06 μ s)

Note: The minimum pulse width is 0.11µs.

- Camera internal logic: 0.11µs (TriggerWidth offset 0µs)
- TTL High Active: 0.53µs (TriggerWidth offset -0.42µs)
- TTL Low Active: 0.17µs (TriggerWidth offset -0.06µs)

Delay Time from Trigger Input to Start of Exposure

On this camera, when TriggerMode is set to On, there is a delay time between the external trigger input and the start of the exposure. The delay time is shown below.

	ExposureMode		
	Off	Timed	TriggerWidth
Camera Internal Logic	2.00 µs	0.13 µs	0.91 µs
TTL High Active	2.13 µs	0.25 µs	0.21 µs
TTL Low Active	2.41 µs	0.54 µs	0.50 µs
Opto High Active	2.0 µs	0.2 µs	0.16 µs
Opto Low Active	2.0 µs	0.2 µs	0.16 µs

Timing Chart

This section shows the timing charts under the following conditions on each model.

- [ExposureMode = Timed](#)
- [ExposureMode = Off](#)
- [ExposureMode = TriggerWidth](#)

Notes:

- ExposureActive includes the exposure offset time. For more information, see "[Actual Exposure Time](#)".
- For the TL model, the timing charts use the channel with the longest exposure time (Channel A in the example below) as the "ExposureActive" signal if the ExposureTime is configured individually for each channel (Individual Mode; ExposureModeOption = Individual). Please keep this in mind when referring to anything other than the exposure timing.

In Individual Mode, the actual exposure time starts with the channel with the longest exposure time and ends with the channel with the shortest exposure time, so that the exposures end at the same time (see example below). For more information, see "[Exposure Mode](#)" and "[ExposureActive Signal](#)".

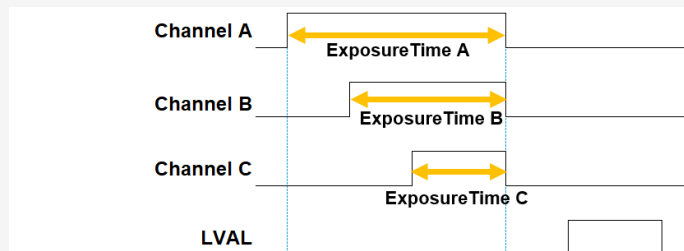

- On this camera, when TriggerMode is set to On, there is a delay time between the external trigger input and the start of the exposure. For more information, see "[Delay Time from Trigger Input to Start of Exposure](#)".

ExposureMode = Timed

Note: The following are timing charts when TriggerMode = On and BinnigHorizontal = 1 (Off).

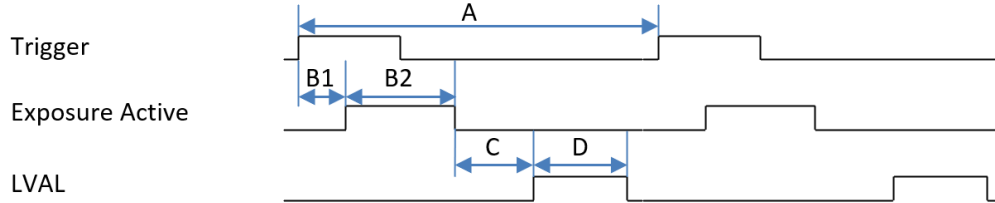

SW-2005TL-5GE (Width = 2048)

PixelFormat	Trigger Period[A] (μs)	Delay Time from Trigger to Exposure Active[B1] (μs)	Exposure Active to Non Active[B2] (μs)	Period from Exposure Active Falling to LVAL rising[C] (μs)	LVAL Active[D] (μs)
RGB8	22.39	0.58	3.22	33.86	6.56
RGB10V1Packed	22.39	0.58	3.22	33.88	6.56
RGB10p32	22.39	0.58	3.22	33.88	6.56
RGB12V1Packed	22.39	0.58	3.22	33.85	6.56

SW-2005M-5GE (Width = 2048)

PixelFormat	Trigger Period[A] (μs)	Delay Time from Trigger to Exposure Active[B1] (μs)	Exposure Active to Non Active[B2] (μs)	Period from Exposure Active Falling to LVAL rising[C] (μs)	LVAL Active[D] (μs)
Mono8	5.80	0.20	1.64	25.38	3.28
Mono10	7.20	0.20	1.64	25.38	3.28
Mono12	7.15	0.20	1.64	25.38	3.28
Mono10Packed	5.80	0.20	1.64	25.39	3.28
Mono12Packed	5.80	0.20	1.64	25.36	3.28

SW-4005BL-5GE (Width = 4096)

PixelFormat	Trigger Period[A] (μs)	Delay Time from Trigger to Exposure Active[B1] (μs)	Exposure Active to Non Active[B2] (μs)	Period from Exposure Active Falling to LVAL rising[C] (μs)	LVAL Active[D] (μs)
RGB8	23.44	0.22	3.22	31.60	13.11
RGB10V1Packed	27.15	0.21	3.23	31.60	13.11
RGB10p32	27.16	0.21	3.22	31.60	13.11
RGB12V1Packed	30.43	0.22	3.22	31.60	13.11
BiColorRGBG8	23.44	0.21	3.22	31.60	13.11
BiColorRGBG10	27.16	0.22	3.22	31.60	13.11
BiColorRGBG12	27.16	0.22	3.22	31.60	13.11
BiColorRGBG10p	23.45	0.22	3.22	31.60	13.11
BiColorRGBG12p	23.44	0.23	3.22	31.60	13.11

SW-4005M-5GE (Width = 4096)

PixelFormat	Trigger Period[A] (μs)	Delay Time from Trigger to Exposure Active[B1] (μs)	Exposure Active to Non Active[B2] (μs)	Period from Exposure Active Falling to LVAL rising[C] (μs)	LVAL Active[D] (μs)
Mono8	11.85	0.22	2.17	37.47	6.56
Mono10	13.79	0.22	2.17	37.44	6.56
Mono12	13.79	0.22	2.17	37.44	6.55
Mono10Packed	11.85	0.22	2.17	37.49	6.55
Mono12Packed	11.85	0.22	2.17	37.48	6.56

ExposureMode = Off

Note: The following are timing charts when TriggerMode = On and BinnigHorizontal = 1 (Off).

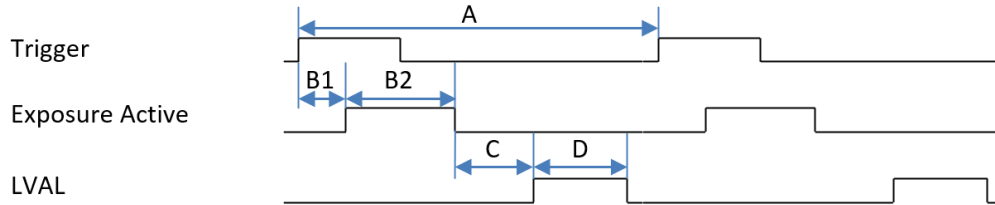

SW-2005TL-5GE (Width = 2048)

PixelFormat	Trigger Period[A] (μs)	Delay Time from Trigger to Exposure Active[B1] (μs)	Exposure Active to Non Active[B2] (μs)	Period from Exposure Active Falling to LVAL rising[C] (μs)	LVAL Active[D] (μs)
RGB8	22.39	0.58	3.22	33.86	6.56
RGB10V1Packed	22.39	0.58	3.22	33.88	6.56
RGB10p32	22.39	0.58	3.22	33.88	6.56
RGB12V1Packed	22.39	0.58	3.22	33.85	6.56

SW-2005M-5GE (Width = 2048)

PixelFormat	Trigger Period[A] (μs)	Delay Time from Trigger to Exposure Active[B1] (μs)	Exposure Active to Non Active[B2] (μs)	Period from Exposure Active Falling to LVAL rising[C] (μs)	LVAL Active[D] (μs)
Mono8	5.82	2.09	5.43	25.41	3.28
Mono10	7.08	2.09	6.80	25.41	3.28
Mono12	7.08	2.09	6.80	25.41	3.28
Mono10Packed	5.90	2.09	5.41	25.41	3.28
Mono12Packed	5.90	2.09	5.41	25.41	3.28

SW-4005BL-5GE (Width = 4096)

PixelFormat	Trigger Period[A] (μs)	Delay Time from Trigger to Exposure Active[B1] (μs)	Exposure Active to Non Active[B2] (μs)	Period from Exposure Active Falling to LVAL rising[C] (μs)	LVAL Active[D] (μs)
RGB8	23.45	3.68	23.07	31.60	13.11
RGB10V1Packed	27.16	3.73	26.75	31.60	13.12
RGB10p32	27.16	3.72	26.75	31.60	13.11
RGB12V1Packed	30.43	3.72	30.01	31.60	13.11
BiColorRGBG8	23.44	3.7	23.06	31.60	13.11
BiColorRGBG10	27.16	3.72	26.75	31.60	13.11
BiColorRGBG12	27.16	3.73	26.75	31.60	13.11
BiColorRGBG10p	23.45	3.71	23.02	31.60	13.11
BiColorRGBG12p	23.44	3.71	23.06	31.60	13.11

SW-4005M-5GE (Width = 4096)

PixelFormat	Trigger Period[A] (μs)	Delay Time from Trigger to Exposure Active[B1] (μs)	Exposure Active to Non Active[B2] (μs)	Period from Exposure Active Falling to LVAL rising[C] (μs)	LVAL Active[D] (μs)
Mono8	11.85	2.66	11.44	37.48	6.55
Mono10	13.79	2.65	13.49	37.46	6.56
Mono12	13.79	2.68	13.49	37.46	6.56
Mono10Packed	11.85	2.66	11.43	37.47	6.56
Mono12Packed	11.85	2.66	11.43	37.46	6.56

ExposureMode = TriggerWidth

Note: The following are timing charts when TriggerMode = On and BinnigHorizontal = 1 (Off).

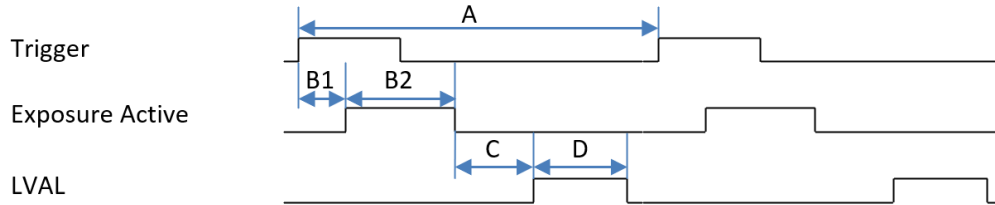

SW-2005TL-5GE (Width = 2048)

PixelFormat	Trigger Period[A] (μs)	Delay Time from Trigger to Exposure Active[B1] (μs)	Exposure Active to Non Active[B2] (μs)	Period from Exposure Active Falling to LVAL rising[C] (μs)	LVAL Active[D] (μs)
RGB8	22.38	0.54	6.11	33.86	6.55
RGB10V1Packed	22.38	0.54	6.06	33.88	6.55
RGB10p32	22.38	0.54	6.06	33.86	6.55
RGB12V1Packed	22.38	0.54	6.06	33.85	6.55

SW-2005M-5GE (Width = 2048)

PixelFormat	Trigger Period[A] (μs)	Delay Time from Trigger to Exposure Active[B1] (μs)	Exposure Active to Non Active[B2] (μs)	Period from Exposure Active Falling to LVAL rising[C] (μs)	LVAL Active[D] (μs)
Mono8	5.80	0.5	1.59	25.37	3.27
Mono10	7.08	0.5	1.59	25.38	3.27
Mono12	7.09	0.5	1.59	25.40	3.27
Mono10Packed	5.80	0.5	1.59	25.37	3.27
Mono12Packed	5.79	0.5	1.59	25.40	3.27

SW-4005BL-5GE (Width = 4096)

PixelFormat	Trigger Period[A] (μs)	Delay Time from Trigger to Exposure Active[B1] (μs)	Exposure Active to Non Active[B2] (μs)	Period from Exposure Active Falling to LVAL rising[C] (μs)	LVAL Active[D] (μs)
RGB8	23.47	0.17	8.12	31.60	13.11
RGB10V1Packed	27.18	0.17	8.12	31.60	13.11
RGB10p32	27.18	0.18	8.12	31.60	13.11
RGB12V1Packed	30.45	0.18	8.11	31.60	13.11
BiColorRGBG8	23.47	0.18	8.07	31.60	13.11
BiColorRGBG10	27.18	0.17	8.12	31.60	13.11
BiColorRGBG12	27.18	0.18	8.07	31.60	13.11
BiColorRGBG10p	23.47	0.17	8.12	31.60	13.11
BiColorRGBG12p	23.43	0.17	8.12	31.60	13.11

SW-4005M-5GE (Width = 4096)

PixelFormat	Trigger Period[A] (μs)	Delay Time from Trigger to Exposure Active[B1] (μs)	Exposure Active to Non Active[B2] (μs)	Period from Exposure Active Falling to LVAL rising[C] (μs)	LVAL Active[D] (μs)
Mono8	11.85	0.18	5.07	37.47	6.55
Mono10	13.78	0.17	5.06	37.45	6.55
Mono12	13.78	0.18	5.01	37.45	6.55
Mono10Packed	11.85	0.18	5.06	37.48	6.55
Mono12Packed	11.85	0.17	5.01	37.48	6.56

GPIO (Digital Input/Output Settings)

Related Setting Items: [DigitalIOControl](#)

The camera is equipped with GPIO (general-purpose input/output) functions for generating and using combinations of triggers and other necessary signals within the camera and of signals output from the camera to the system such as those used for lighting equipment control.

These signals can be used as triggers and other necessary signals within the camera or as signals output from the camera to the system, such as those used for lighting equipment control.

Note: See "[Recommended External Input Circuit Diagram](#)" for recommended external circuit examples.

You can check the status of each digital I/O as shown in the table below with LineStatusAll.

Line Selector	Line Mode	Line Format	Line Inverter	Line Status All	Line Source
Line1 TTL Out1	Output	TTL	False / True	bit 0	User-specified
Line4 TTL In1	Input	TTL	False (Fixed)	bit 3	-
Line5 Opt In1	Input	OptoCoupled	False (Fixed)	bit 4	-
Line12 TTL Out4	Output	TTL	False / True	bit 11	User-specified
Line14 TTL In4	Input	TTL	False (Fixed)	bit 13	-

Notes:

- Line Status: "Low" signal level is indicated by **False**, and "High" signal level is indicated by **True**.
- Line Status All: The current status of the Line signal is indicated by the above bit field.
- Line Source: Selectable items are listed in "[LineSource Items](#)".

LineSource Items

This section describes each item that can be selected in **LineSource**.

LineSource	Description
AcquisitionActive	From AcquisitionStart to AcquisitionStop. See " Acquisition Control " for reference.
FrameActive	From Frame Exposure to the end of FVAL.
ExposureActive	Camera is doing the exposure. See " ExposureActive Signal " for reference.
LVAL	Image data (line) from the sensor is being read.
PulseGenerator0 ~ 3	PulseGenerator output. For more information, see the following technical note: https://www.jai.com/uploads/documents/Technical-notes/English/TNE-0005-2015XII11-000-TechNote-PulseGenerator-tips.pdf
UserOutput0 ~ 3	Allows you to toggle UserOutput's On / Off on the software. Select the User Output 0 ~ 3 you want to use from UserOutputSelector , and then set the UserOutputValue (High or Low) .
Line4 TTL In1	TTL In1
Line5 Opt In1	Opt In1
Line14 TTL In4	TTL In4
Logic Block0 ~ 3	Logic Block output. See " Logic Block Control " for reference.
EncoderTrigger	Encoder output. See " Connecting Rotary Encoders " for reference.
EncoderDirection	Direction of encoder rotation. See " Rotation Direction " for reference.

ExposureActive Signal

Perform external output for the timing at which video is accumulated to the sensor. The signal is output to the DC IN / TRIG IN connector (12-pin round).

Note: ExposureActive includes the exposure offset time. For more information, see "[Actual Exposure Time](#)".

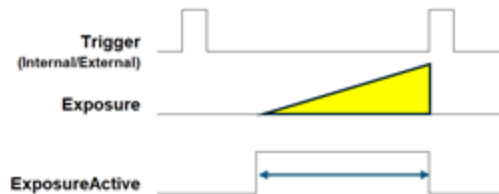

ExposureActiveSource (TL model Only)

When **ExposureTimeMode** is set to **Individual** ([Exposure Mode](#)), the timing of the ExposureActive signal output will be different for each RGB channel due to the difference in RGB exposure time. Therefore, when setting **ExposureActive** for a **LineSource**, use **ExposureActiveSource** to specify which signal is output as ExposureActive (Common, Red, Green, Blue).

When **ExposureActiveSource** is set to **Common**, the channel with the longest exposure time is output as the ExposureActive signal. In the following example, the timing of the red channel is output as the ExposureActive signal.

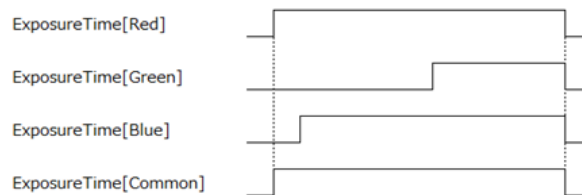

Pulse Generator

Related Setting Items: [PulseGenerator](#)



Technical Notes

Tips for using the Pulse Generator

By using this function, any signal can be generated inside the camera.

The following is an example of signal generation.

Settings

PulseGeneratorStartPoint = 2

PulseGeneratorEndPoint = 6

PulseGeneratorLength = 10

PulseGeneratorPulseWidth = 4

PulseGeneratorClearSyncMode = AsyncMode

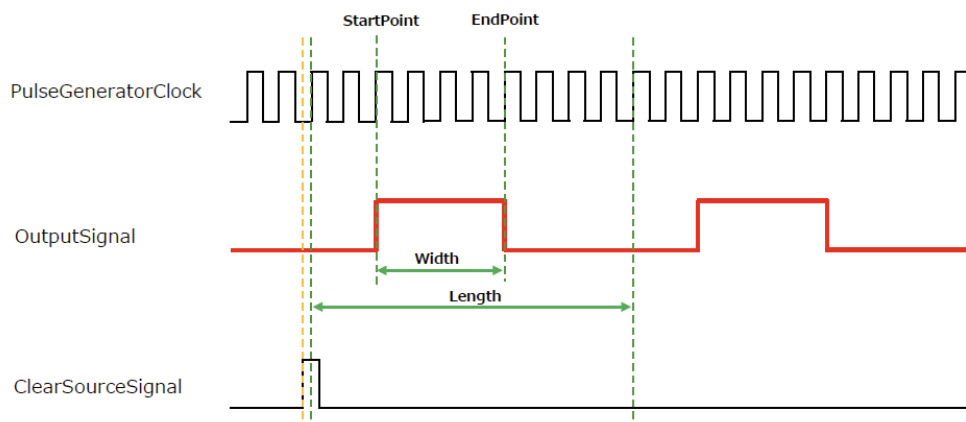

The table below shows the PulseGeneratorClearSource signals that can be set.

- ExposureActive, LVAL, PulseGenerator0-3*, UserOutput0-3, Line4 TTL In1, Line5 Opt In1, Line14 TTL In4, Logic Block0-3, EncoderTrigger

Note: *PulseGenerator0-3: You cannot select the same Pulse Generator that is currently selected. For example, if Pulse Generator 0 is selected, you cannot select Pulse Generator 0 as the Clear source.

Gain Control

Related Setting Items: [AnalogControl](#)

Gain control can be performed in the following two modes on this camera.

- Notes:**
- For details on how to configure the settings, see "[Adjust the Gain](#)."
 - The Gain setting is configured in multipliers. For more information, see "[Comparison of the Decibel Display and Multiplier Display](#)."

Color Model

Master Mode (Individual Gain Mode = Off)	Individual Gain Mode = On
<p>Adjust the DigitalAll (master gain) setting first, and then adjust the DigitalRed and DigitalBlue setting values to perform fine adjustment.</p>	<p>Adjust the DigitalGreen, DigitalRed, and DigitalBlue setting values to adjust the gain.</p> <p>This mode allows a wider range of adjustment by the user when compared to Master Mode.</p>

Monochrome Model

Adjust the gain using the **DigitalAll** setting.

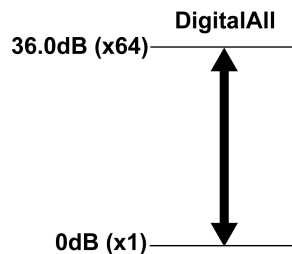

Sensor Gain Mode

Related Setting Items: [AnalogControl](#)

Note: This function is supported on the SW-2005 models that operate with firmware version DV0103 or later. (The SW-4005 models do not support this function).

This function allows you to configure the sensor's gain mode.

- **LowGainMode** (default) provides images with reduced noise but requires a brighter lighting environment due to lower sensitivity.
- **HighGainMode** increases sensitivity and allows imaging in low-light conditions, but the noise level will be higher.

Note: The SW-2005 camera operating with firmware version DV0102 runs in HighGainMode.

The table below summarizes the comparison between LowGainMode and HighGainMode.

	SW-2005TL model	SW-2005M model
Sensitivity	LowGainMode reduces sensitivity by 40% compared to HighGainMode.	LowGainMode reduces sensitivity by 41% compared to HighGainMode.
DR (Dark SN)	Same performance	Same performance
SNR (Bright SN)	LowGainMode improves SNR by 3dB compared to HighGainMode	
Linearity	Good	Good

Examples

The following shows examples of images for LowGainMode and HighGainMode.

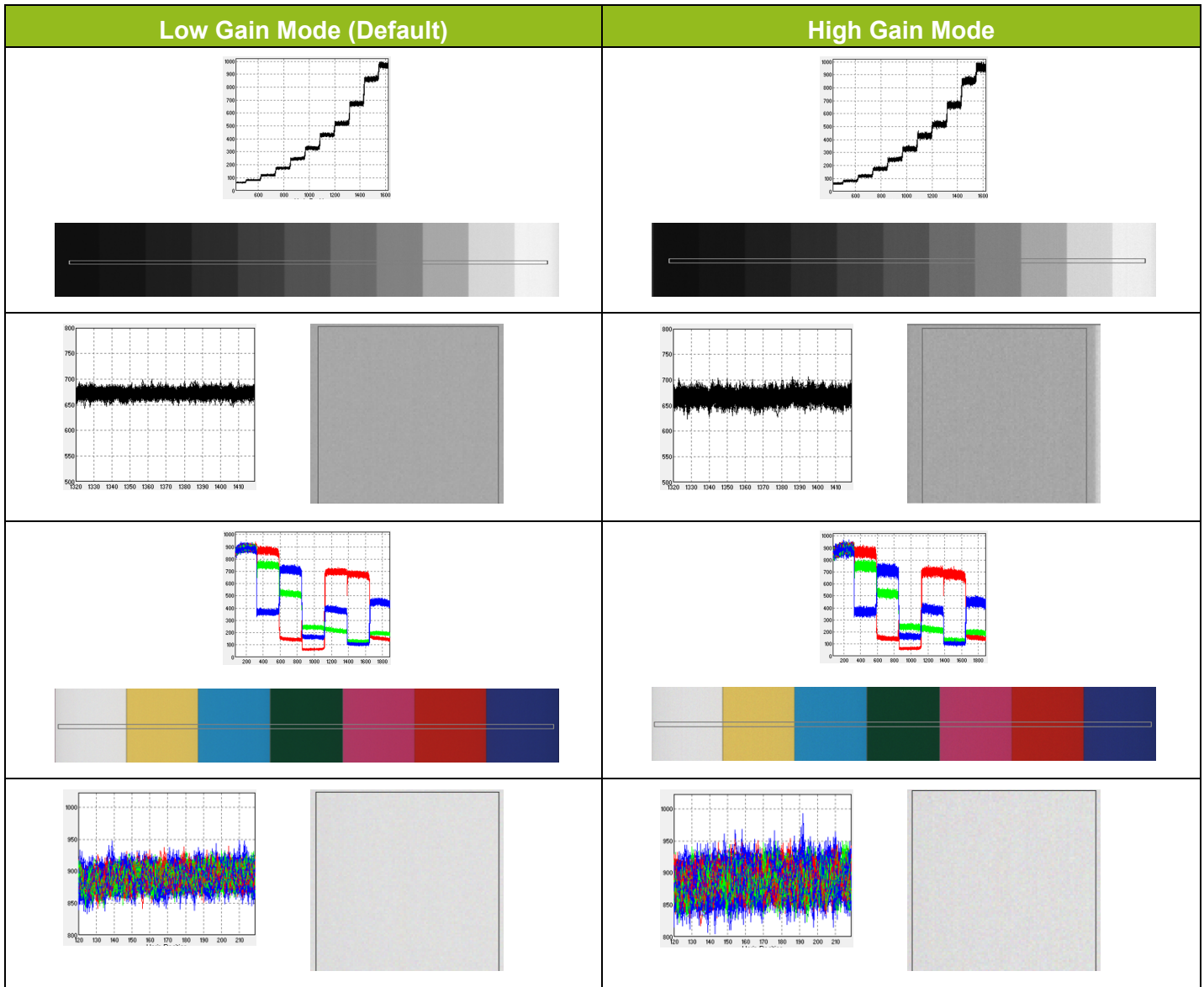

Gamma Function

Related Setting Items: [AnalogControl](#)

The Gamma function corrects the output signals from the camera beforehand (reverse correction), taking into consideration the light-emitting properties of the monitor display. As the light-emitting properties of the monitor are not linear, the entire image may be darker or the gradation in the dark areas may be less noticeable when camera outputs are displayed without processing.

The Gamma function can be used to correct the camera signals with an opposite-direction curve and produce a display that is close to linear.

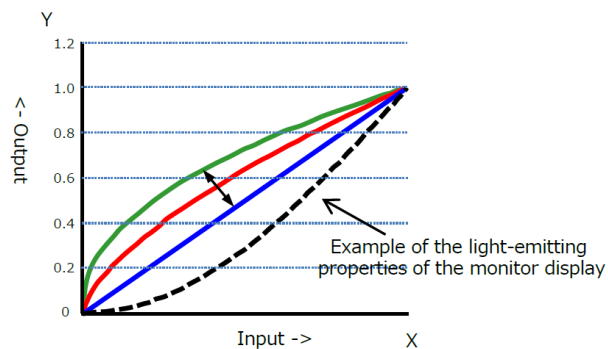

To use the Gamma function

1. Select the correction value from **Gamma**. The selectable values are as follows: 0.45, 0.5, 0.55, 0.6, 0.65, 0.75, 0.8, 0.9, 1.0
2. Select **Gamma** from **LUTMode**.

Note: You can use the LUT function to configure a curve with more detailed points. For details, see "[LUT \(Lookup Table\)](#)".

LUT (Lookup Table)

Related Setting Items: [LUT Control](#)

The LUT function is used to generate a non-linear mapping between signal values captured on the sensor and those that are output from the camera. You can specify the output curve using 257 setting points (indexes).

To use the LUT function

1. Select **LUT** from **LUTMode** ([AnalogControl](#)).
2. Select the LUT channel you want to control from LUTSelector ([LUT Control](#)). (Red, Green, or Blue)

Note: Color model only

3. Select the LUT Index from **LUTIndex** (0 ~ 256). Indexes represent the possible pixel values captured on the sensor, from the lowest value (Index 0) to the highest (Index 256). For example, Index 0 represents a full black pixel and Index 256 represents a full white pixel.
4. Set the LUT output value for the selected index in **LUTValue** (0 ~ 4095).

LUT values

LUT values range from 0 at the lowest to 4095 at the highest. Linear interpolation is used to calculate LUT values between the index points.

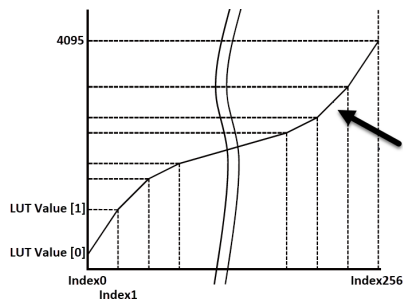

Interpolation using the average values of data to the left and right is used to determine values between points.

Color Space Conversion (ColorTransformationControl)

Related Setting Items: [Color Transformation Control](#)

This camera allows you to convert the standard color space (RGB) that is used to produce colors into other color spaces.

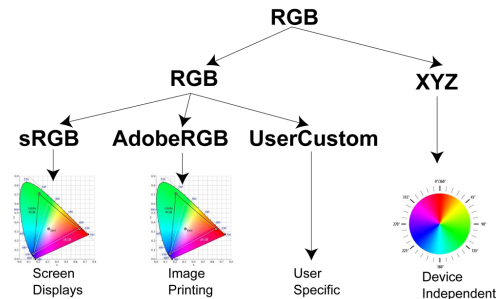

Note: This function is only supported on the color model.

How to Configure

1. Select the color space (RGB, XYZ) you want to use from **ColorTransformationMode** ([Color Transformation Control](#)).
2. When **RGB** is selected, select the details (sRGB, AdobeRGB, UserCustom) from **ColorTransformationRGBMode**.

Note: If you select other than RGB, **ColorTransformationRGBMode** is fixed to **Off**.

3. When **UserCustom** is selected,
 - i. Select the item you want to configure in **ColorMatrixValueSelector**.
 - ii. Configure the value (-2 to +2) in **ColorMatrixValue**.

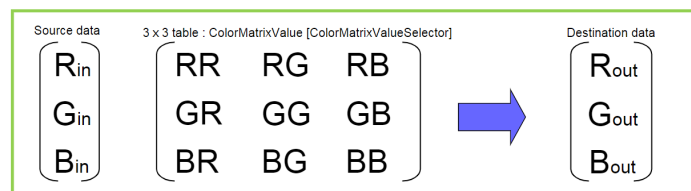

Caution: If you set the color space to XYZ, Control Tool will not display the images captured by the camera properly. To display them properly, XYZ-compatible image processing must be performed on the computer side.

Shading Correction

Related Setting Items: [Shading](#)

The Shading Correction function corrects non-uniformity (i.e., shading) in the amount of light generated by the lens and lighting equipment. This camera supports the following shading correction modes.

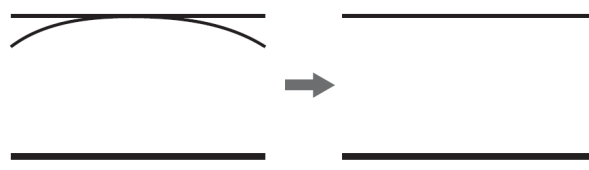
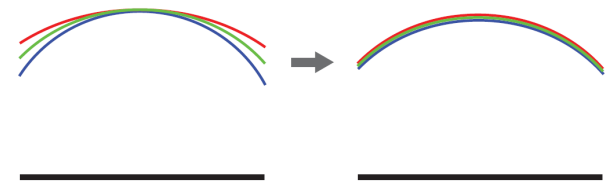
FlatShading, FlatShadingUserAreaBE	ColorShading*, ColorShadingUserArera BE*
	
<p>The highest brightness level is used as a reference, and other areas are corrected to match that brightness level. The area to calculate the correction value varies depending on the mode (see table below), but the correction value is applied to all areas (= WidthMax).</p>	<p>R-channel and B-channel properties are adjusted by using the G-channel shading properties as a reference. The area to calculate the correction value varies depending on the mode (see table below), but the correction value is applied to all areas (= WidthMax).</p>

Descriptions of Each Mode

ShadingCorrection Mode	Calculation Area	Correction Area	When the Image Is Too Bright or Dark
FlatShading	Full ROI	Full ROI	The shading correction attempt fails and an error message is displayed.
FlatShading UserAreaBE	User-specified ROI		The camera corrects the shading as close as possible to the target level.
ColorShading*	Full ROI		The shading correction attempt fails and an error message is displayed.
ColorShading UserAreaBE*	User-specified ROI		The camera corrects the shading as close as possible to the target level.

Notes:

- *Color model only
- For details on ROI, see "[ROI \(Regional Scanning Function\)](#)".
- For more information on the Shading Correction on line scan cameras, see "<https://news.jai.com/blog/lens-vignetting>".

Shading Correction Blocks

The camera makes adjustments in blocks. The block Index number (ShadingDataIndex) can be used to view and change the settings per block (ShadingData). For more information, see "[How to Configure the Shading Correction Function](#)".

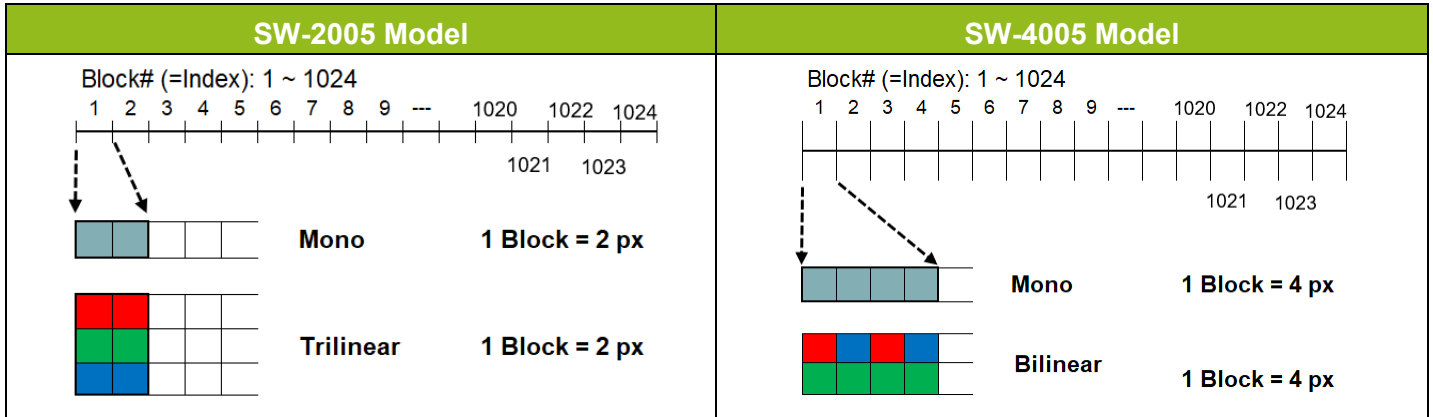

How to Configure the Shading Correction Function

This section explains how to configure the Shading Correction function.

Note: The option / selection with "*" is supported only on the color model.

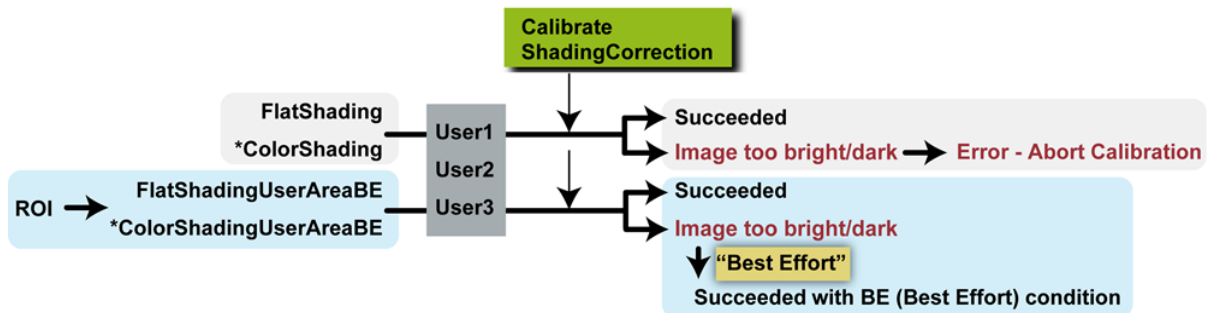

1. If you want to specify the area to calculate the correction value, configure the area with the **Width** and **OffsetX** settings [[ImageFormatControl](#)]. For more information, see [ROI \(Regional Scanning Function\)](#).
2. Select the Shading Correction Mode from **ShadingCorrectionMode**. (Flat Shading (Default), Flat Shading User Area BE, Color Shading*, Color Shading User Area BE*)

Note: For detailed information of each mode, see "[Shading Correction](#)".

3. Select the user area (User1 ~ 3) where you save the shading correction data from **ShadingMode**.
4. Display a white chart under a uniform light and execute **CalibrateShadingCorrection**.

5. Once the shading correction is successfully completed, the shading correction values are automatically saved to the area specified in **ShadingMode**. Also, the calibration result "**Succeeded**" is displayed in **ShadingDetectResult**.
6. If the image is too bright or too dark, the camera will operate differently depending on the selected Shading Correction Mode.
 - **FlatShading** or **ColorShading***: The shading correction attempt fails, and "**Error1 - Image was too bright**" or "**Error2 - Image was too dark**" will display in **ShadingDetectResult**.
 - **FlatShadingUserAreaBE** or **ColorShadingUserAreaBE***: The camera continues to make "best effort" adjustments and corrects the shading as close as possible to the target level. Once the correction is completed, the shading correction values are automatically saved to the area specified in **ShadingMode**. Also, the calibration result "**Succeeded with BE condition**" is displayed in **ShadingDetectResult**.
7. Optionally, you can view or change the setting of each correction block.
 1. Select a color channel (Red, Green, or Blue) from **ShadingDataSelector*** (color model only) and an Index number (block number) from **ShadingDataIndex**.
 2. The setting selected by **ShadingDataSelector** and **ShadingDataIndex** is displayed in **ShadingData**. To change the setting, overwrite the value (0x4000 = 1x).

Note: The set **ShadingData** value is rounded down to multiples of 4.

3. Execute **ShadingDataSave**. The currently set **ShadingData** will be overwritten and save to the area specified in **ShadingMode**.

Note: The setting is immediately reflected in the image, but is not saved until **ShadingDataSave** is executed. If **ShadingMode** is changed without executing **ShadingDataSave**, the setting will be discarded.

ShadingDetectResult

A list of correction results is shown below.

Result	ShadingCorrection Mode	Description
Idle	Any	Correction is not being performed.
Succeeded	FlatShading, ColorShading	Correction was completed successfully. The correction data calculated from the entire image area was applied to the entire image area and saved in the user area specified by ShadingMode .
	FlatShadingUserAreaBE, ColorShadingUserAreaBE	Correction was completed successfully. The correction data calculated from the specified ROI was applied to the entire image area and saved in the user area specified by ShadingMode .

Result	ShadingCorrection Mode	Description
Succeeded with BE condition	FlatShadingUserAreaBE, ColorShadingUserAreaBE	Performed correction as close as possible to the target level. Could not perform normal correction because the brightness in the specified ROI area was outside the range.
Error1 - Image was too bright	FlatShading, ColorShading	Correction failed. The image was too bright.
Error2 - Image was too dark	FlatShading, ColorShading	Correction failed. The image was too dark.
Error3 - Could not calibrated	Any	Could not perform the adjustment due to one of the following reasons: <ul style="list-style-type: none"> • The image is not being output. • TestPattern[ImageFormatControl] is set to anything other than Off. • ShadingMode is set to Off.

Pixel Sensitivity Correction (DSNU, PRNU)

Related Topic: [Correction](#)

Correct variations between the sensor's pixels.

Calibration must be performed within the camera and correction data must be created beforehand. DSNU (PixelBlackCorrect) / PRNU (PixelGainCorrect) can be reduced using that correction data.

We recommend performing calibration and creating correction data whenever the line rate setting is changed significantly.

Refer to the following topics on how to perform the calibration.

- [DSNU Correction \(Pixel Black Correct\)](#)
- [PRNU Correction \(Pixel Gain Correct\)](#)

Notes:

- Correction data is saved for DSNU (PixelBlackCorrect) / PRNU (PixelGainCorrect) according to the conditions adjusted at the factory.
- A single correction data entry can be saved on the camera for each user. When calibration is performed, the correction data is saved to the non-volatile ROM at the same time.

Chromatic Aberration Correction

Related Setting Items: [Correction](#)

This function corrects the magnification differences between the color channels which is caused by the chromatic aberration of the lens. In simpler terms when the object appears with a slightly different width on the blue, green and red channels. You can save correction data for three types of lenses.

Specify the number of pixels to delay or advance the R channel and B channel using the G channel as a reference. The correction range is -2.0 to +2.0-4.0 to +4.0 in steps of 0.1.

Notes:

- This function is supported only on the color model.
- Perform this function "before" mounting the camera to a system/device. If you use the [Tilt View Correction](#) function as well, perform the Tilted View function "after" the camera is mounted to a system/device. Using this approach, the camera and lens are already calibrated before the tilted view correction is applied which makes the manual tilt correction easier.
- This function assumes that the amount of deviation between the left and right is identical. If the amount of deviation between the left and right is not identical, correction will not be performed properly.

How to Configure

Follow these steps "before" mounting the camera to a system/device.

1. Select the area to apply or save the correction value in **ChromaticAberrationCorrectionMode** (Lens1 ~ 3).
2. Select how the correction is performed in **ChromaticAberrationCorrectionMethod**. Whichever option is selected, the correction is performed with the image center as the origin and the ChromaticAberrationCorrection value at both ends of the image.
 - **Simple Interpolation** (Default): Perform a two-point linear interpolation.
 - **Linear Spline Interpolation**: Performs piecewise linear interpolation using a quadratic curve formula.
 - **Custom**: Modify each correction point as desired.

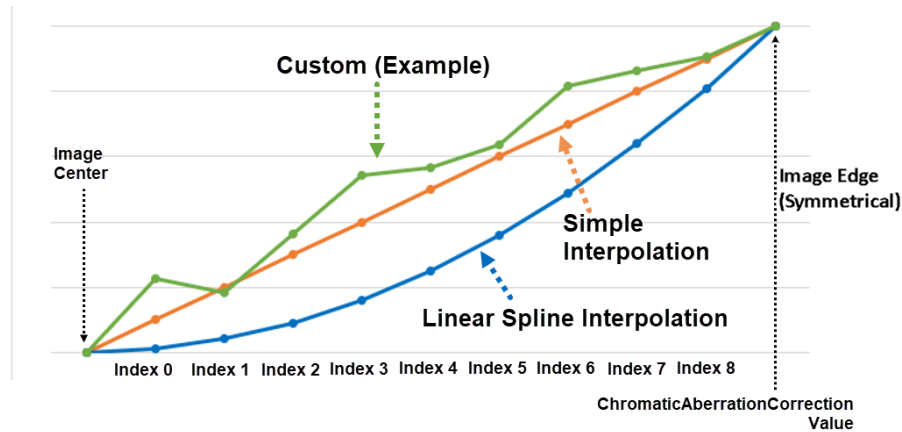

3. Configure the correction settings, which vary depending on the selected correction method.

- **Simple Interpolation:** Select **R Channel** from **ChromaticAberrationCorrectionSelector** and set the correction value in **ChromaticAberrationCorrection**.
- **Linear Spline Interpolation:** Configure the correction settings as follows.
 1. Select **R Channel** from **ChromaticAberrationCorrectionSelector**.
 2. Select the index you want to configure from **ChromaticAberrationCorrectionIndex**, and set the correction value for the selected index in **ChromaticAberrationCorrectionCoeff**.
 3. Set the amount of correction for both ends of the image in **ChromaticAberrationCorrection**.
- **Custom:** Configure the correction settings as follows.
 1. Select **R Channel** from **ChromaticAberrationCorrectionSelector**.
 2. Select the index you want to configure from **ChromaticAberrationCorrectionIndex**, and set the correction ratio for the selected index in **ChromaticAberrationCorrectionRatio**.
 3. Set the amount of correction for both ends of the image in **ChromaticAberrationCorrection**.

Caution: If the **ChromaticAberrationCorrectionMethod** is set to anything other than Custom and the **ChromaticAberrationCorrectionRatio** value is changed manually, **ChromaticAberrationCorrectionMethod** will be forced to change to **Custom**.

4. Select **B Channel** from **ChromaticAberrationCorrectionSelector**, and configure the correction settings as R Channel.
5. Execute **ChromaticAberrationCorrectionSave** to save the settings. The saved settings are for the area (Lens1 ~ 3) selected in **ChromaticAberrationCorrectionMode**.

Note: When the selected correction method is **Linear Spline Interpolation** or **Custom**, the correction value of each index will be calculated using the following formula.

- **[Linear Spline Interpolation]:** Correction value [ChromaticAberrationCorrectionIndex] = pow (ChromaticAberrationCorrectionIndex/10, ChromaticAberrationCorrectionCoeff) x ChromaticAberrationCorrection
- **[Custom]:** Correction value [ChromaticAberrationCorrectionIndex] = ChromaticAberrationCorrection x ChromaticAberrationCorrectionRatio [ChromaticAberrationCorrectionIndex]

Tilt View Correction

Related Setting Items: [Correction](#)

This function corrects the trapezoidal distortion that occurs when a Trilinear or Bilinear camera is placed at an off-axis viewing angle. The below illustrates the tilt view correction for the Trilinear model.

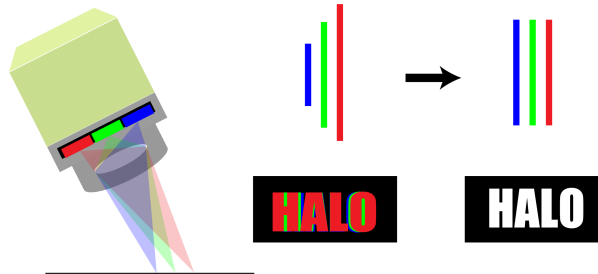

The trapezoidal distortion is caused due to the fact that the optical path from object surface to the closest color channel on the sensor is shorter than the other two color channels. As a result, color fringing, typically referred to as the “halo effect”, occurs. Use this function to make corrections to create a halo-free image.

Notes:

- This function is supported only on the color model.
- Perform this function "after" mounting the camera to a system/device. If you use the [Chromatic Aberration Correction](#) function, perform the Tilted View function "after" the camera is mounted to a system/device. By this way, if only the camera mounting position is changed without changing the lens, only the linear tilt correction needs to be considered without worrying about the quadratic color shift of chromatic aberration.

How to Configure

Follow these steps "after" mounting the camera to a system/device.

1. Select the area to apply the correction value in **TiltViewCorrectionMode** (User1 ~ 3).

Note: Default contains the correction data that was set at the factory.

2. Select the color channel (Red or Blue) to correct from **TiltViewCorrectionSelector**.
3. Set the correction value in **TiltViewCorrection** (-1.9 ~ 1.0, step: 0.1).
4. Execute **TiltViewCorrectionSave** to save the settings. The saved settings are for the area (User1 ~ 3) selected in **TiltViewCorrectionMode**.

Crosstalk Compensation Mode

Related Setting Items: [Correction](#)

Note: This function is only supported on the SW-4005BL model.

The SW-4005BL model is shipped with crosstalk compensation already applied, but depending on the light source and lens used, it may be necessary to re-adjust the compensation amount.

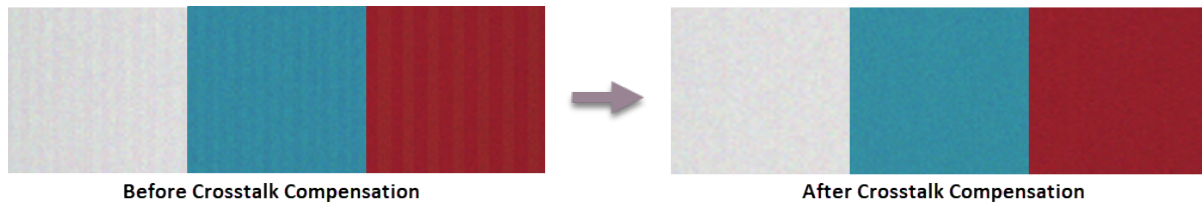

If you see vertical lines (as in the image on the left) on flat white, blue, and red areas of the image, crosstalk compensation is required.

How to Configure

1. Set **CrossTalkCompensationMode** [\[Correction\]](#) to **User**.

Notes:

- Default contains the correction data that was set at the factory. See also "Factory Default Compensation Values".
- **Off** disables the crosstalk compensation.

2. Set the compensation value for Gr pixels with **CrossTalkCompensationValueGr**, and set the compensation value for Gb pixels with **CrossTalkCompensationValueGb**. The setting range is 0 (default) to 20% and can be adjusted in 0.1% steps.

Fine-tune the compensation values while viewing the image or waveform.

- **Fine-tune using images:**

Adjust the crosstalk compensation values for the Gr/Gb pixels so that vertical lines disappear and the image is improved. It is important to check that vertical lines are not only visible in white, but also in red and blue to ensure balance.

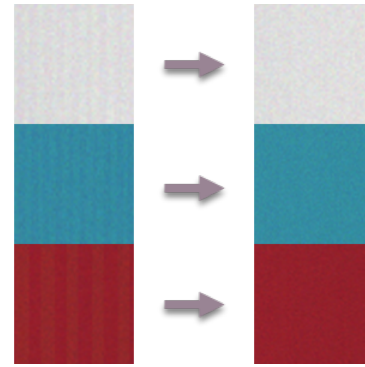

- **Fine-tune using the G channel waveforms:** If the G channel waveform level is jagged, adjust the crosstalk compensation values for the Gr/Gb pixels to improve the jaggedness. It is important to check that not only the waveform for the white image, but also those for the red and blue images are not jagged to ensure balance.

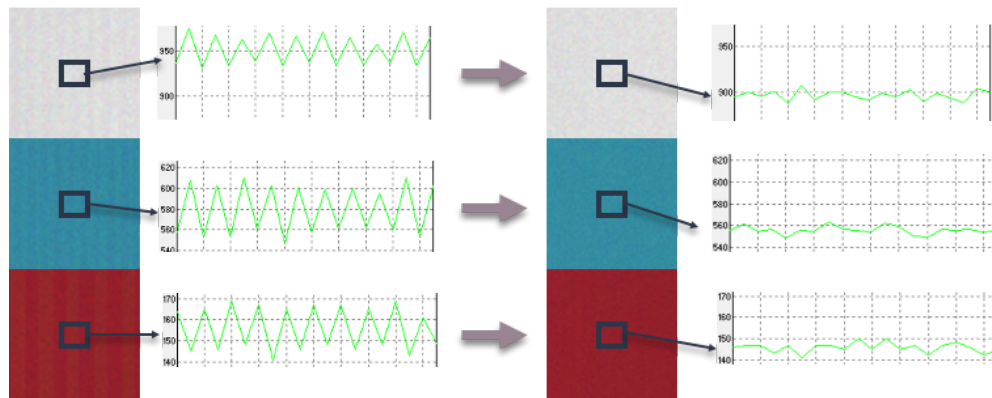

Note: The sensitivity of the G channel changes slightly due to crosstalk compensation. If the compensation value is increased greatly, the sensitivity is decreased.

Factory Default Compensation Values

The compensation values saved in **Default** [CrossTalkCompensationMode] are factory-adjusted based on the following reference values:

- CrossTalkCompensationValueGr = 6.8%
- CrossTalkCompensationValueGb = 10.4%

The above values are optimized for high-brightness flat LED light sources. Please refer to these values when adjusting the crosstalk compensation values.

Noise Reduction Filter Functions

Related Setting Items: [Correction](#)

The camera has noise reduction functions. The noise reduction methods vary depending on the channel.

Three filters are available:

- **FIR Filter:** Apply the FIR (Finite Impulse Response) filter to perform smoothing.

Select the target to apply the filter from Red, Green, Blue, and set the **FIRFilterMode** to **On** (Default = Off). In FIR Filter, the coefficients of the three signals (left, center, right) can be set in the range of -2 to 2. The correction value through the FIR Filter is:

- Left pixel read value x Left pixel coefficient +
- Center pixel read value x Center pixel coefficient +
- Right pixel read value x Right pixel coefficient.

- **MEDIAN Filter:** Apply 1x3 MEDIAN filter to reduce noise.

Select the target to apply the filter from Red, Green, Blue, and set the **Median Filter Mode**. When set to **On**, this function is enabled. (Default = Off).

- **Noise Reduction:** Apply the noise filter using JAI's own algorithm.





Set the noise reduction intensity in 4 levels. Level1 = weak, Level4 = strong.

Any of the above filters can improve SNR, but it affects the sense of resolution and sensitivity. An imaging test should be performed before deciding to use this feature.

Spatial Compensation

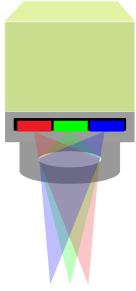
Related Setting Items: [SpatialControl](#)

This function corrects the spatial pixel differences for the R and B lines using the G line as a reference. The following image illustrates the spatial compensation on the Trilinear model.

		Object
		Images acquired by each channel
		After Spatial Compensation

Note: On this camera, the ObjectDirection setting can be used for purposes other than Spatial Compensation. In this case, it can be used not only for color models, but also for monochrome models.

For example, when the camera is paused outputting images with the [Resume Scanning \(Backward Counter\)](#) function, the camera can resume outputting images by changing the **ObjectDirection** setting to reverse the detected direction of the object.

Trilinear Model

On the trilinear model, two modes are available: **Auto** and **Manual**.

Mode	Description
Auto	Using the G line as a reference, automatically adjust and correct the R and B lines collectively. The number of pixels to be corrected for the R and B lines is automatically calculated based on the trigger interval at which the camera is operating, the amount of object movement within the sensor during a single trigger (SpatialCompensationDistance), and the object direction signal.
Manual	Using the G line as a reference, manually adjust and correct each of the R and B lines individually.

How to Compensate

First perform the spatial correction automatically, then adjust manually as needed.

1. Select **Auto** from **SpatialCompensationMode**.
2. Select the source of direction signal from **ObjectDirectionSource**. The direction signal from the rotary encoder (EncoderDirection), the I/O signal input of the camera, or the high/low control signal from UserOutputValue [DigitalIOControl] can be used as the object direction signal.
3. Specify the direction of the object's movement in **ObjectDirection** (**Foward Direction** or **Reverse Direction**).

Note: If you want to reverse the object direction, change this setting. Alternatively, you can reverse the object direction by changing the High/Low setting of the selected ObjectDirectionSource. For example, when **ObjectDirectionSource** is set to **UserOutputValue0** [DigitalIOControl], the object direction can be reversed by changing the **False** (Low)/**True** (High) setting of UserOutputValue0.

4. Set the amount of movement between triggers in subpixels in **SpatialCompensationDistance** (step: 0.01).
5. If the automatic compensation failed to correct the spatial pixel differences, adjust the R and B lines manually. To switch to the manual adjustment, select **Manual** from **SpatialCompensationMode**.
6. If the Red line needs to be adjusted, select **Red** from **SpatialCompensationSelector**, and specify the correction value (step: 0.01) in **SpatialCompensationValue** to align with the G line.
7. If the Blue line needs to be adjusted, select **Blue** from **SpatialCompensationSelector**, and specify the correction value (step: 0.01) in **SpatialCompensationValue** to align with the G line.

Bilinear Model

Follow steps below when performing spacial compensation on the bilinear model.

Note: The bilinear model does not support the automatic compensation.

1. Select the source of direction signal from **ObjectDirectionSource**. The direction signal from the rotary encoder (EncoderDirection), the I/O signal input of the camera, or the high/low control signal from UserOutputValue [\[DigitalIOControl\]](#) can be used as the object direction signal.
2. Specify the direction of the object's movement in **ObjectDirection (Foward Direction or Reverse Direction)**.

Note: If you want to reverse the object direction, change this setting. Alternatively, you can reverse the object direction by changing the High/Low setting of the selected ObjectDirectionSource. For example, when **ObjectDirectionSource** is set to **UserOutputValue0** [\[DigitalIOControl\]](#), the object direction can be reversed by changing the **False** (Low)/**True** (High) setting of UserOutputValue0.

3. Manually adjust and correct the R/B line. Select **RedAndBlue** from **SpatialCompensationSelector**, and specify the correction value (step: 0.01) in **SpatialCompensationValue** to align with the G line.

Counter and Timer Control

Related Setting Items: [Counter and Timer Control](#)

Note: This camera supports the Counter function only.

The Counter function counts up change points in the camera's internal signals using the camera's internal counter, and reads that information from the host side. This function is useful for verifying error conditions via the count value using internal camera operations.

When a problem occurs in a system that includes this camera, comparing the values from multiple counters allows you to verify the extent of normal operability and can be useful when investigating the cause of the problem.

The following counters are available on this camera, and the functions that can be counted are fixed for each counter.

Counter Selector	Counter Event Source (Fixed)	Counter Event Activation
Counter0	Counts the number of Line Trigger instances.	Rising Edge (Fixed)
Counter1	Counts the number of Line Start instances.	Rising Edge (Fixed)
Counter2	Counts the number of Exposure Start instances.	Rising Edge (Fixed)
Counter3	Counts the number of Frame Trigger instances.	Rising Edge (Fixed)
Counter4	Counts the number of Frame Start instances.	Rising Edge (Fixed)
Counter5	Counts the number of FrameTransferEnd instances.	Falling Edge (Fixed)

Connecting Rotary Encoders

Related Setting Items: [EncoderControl](#)

Encoders are useful in line scan applications where line triggers need to be tied to motion, such as applications using conveyors with varying belt speeds.

If the object is moving at a constant speed, a fixed line rate can be set. In most cases, however, the speed of the belt speed is not always constant and must be triggered by an encoder to ensure that the speed of the object and the image acquisition are always synchronized. If the line rate and the belt speed do not match, the pixels will not be square and the image of the object will appear stretched or shrunk (see images below).

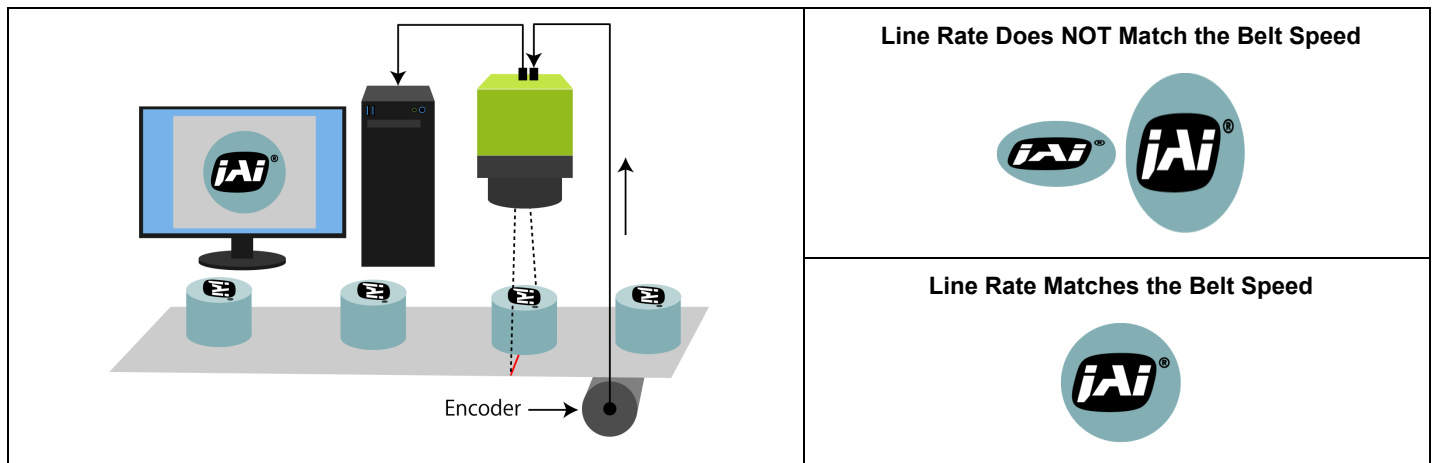

Note: JAI tests the encoder-related functions with a 2-Phase (Phase A and Phase B) incremental encoder.

How to Configure

1. Connect the two signals (Phase A and Phase B) from the rotary encoder to the camera's inputs (**EncoderSourceA** and **EncoderSourceB**). The options are: Line4 TTL In1, Line5 Opt In1, Line14 TTL In4.

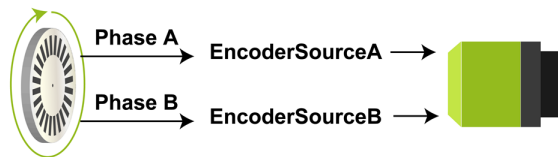

2. Select the encoder trigger method in **EncoderTriggerOption** and configure the setting.
 - **EncoderDivider** (Default): Specify the number of triggers to generate as a ratio (65536 / EncodeDivider value). For more information, see "[EncoderDivider Trigger Option](#)".

Note: With this setting, input pulses are generated on the rising edge of the Phase A signal.

- **EncoderDetection:** Specify the number of edges to pass between each encoder trigger signal. The number of edges to pass is specified by **EncoderEdgeDetectionPassCount**. For more information, see "[EdgeDetection Trigger Option](#)".

Note: With this setting, input pulses are generated on the rising edge and falling edge of both the Phase A and B signals.

3. Specify the condition under which the camera outputs images in **EncoderOutputMode**.

- **PositionUp:** The camera outputs images at all new positions in the positive direction (when **ObjectDirection** [[SpatialControl](#)] is set to **Forward Direction**).
- **PositionDown:** The camera outputs images at all new positions in the negative direction (when **ObjectDirection** [[SpatialControl](#)] is set to **Reverse Direction**).
- **Motion** (Default): The camera outputs images at all motion increments in both directions.

Note: For more information, see "[Resume Scanning \(Backward Counter\)](#)".

4. When **EncoderOutputMode** is set to **PositionUp** or **PositionDown**, **EncoderOutputMaskedCount** displays the number of pulses generated during the reverse rotation.

- **EncoderOutputMaskedCount** counts up while reversing.
- **EncoderOutputMaskedCount** counts down when the reverse rotation is complete and the encoder rotates in the direction set by **PositionUp** or **PositionDown**. When the counter reaches 0, the camera resumes image output.

Note: For more information, see "[Resume Scanning \(Backward Counter\)](#)" and "[Rotation Direction](#)".

5. If necessary, configure the following settings.

- **EncoderFilter:** Enable the low-pass filter for the signal to prevent unintended operations due to signal noise from the rotary encoder. Specify the number of cycles from a range of 0 to 150 ns.

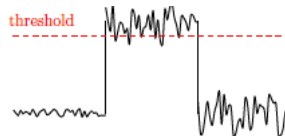

- **EncoderStrobe:** Specify the strobe length of the generated signal (10 ~ 2550 ns).
- **EncoderAveragingInterval:** When **EncoderOutputMode** is set to **EncoderDivider** and **EncoderDvidier** is not set to an integer multiple of 65536, use this setting if the reliability of the interval of the signal output from the rotary encoder is low (some signal interval is extremely long or

short; the encoder's jitter is large). When this function is enabled, internal processing is performed by averaging the interval of several previous signals.

- **EncoderMaxIntervalForNonDecimationMode:** When **EncoderOutputMode** is set to **EncoderDivider** and **EncoderDivider** is not set to an integer multiple of 65536, set the maximum interval period of the output signal.

When set to 0 (Default), the trigger output period is calculated using only the encoder input period. When set to anything other than 0, the trigger output period is calculated using the encoder input period and this setting.

Note: If the time interval of the output of the rotary encoder fluctuates greatly, the output of the camera's internal trigger generated may also fluctuate greatly.

For example, if the belt is stopped for a long time and no signal is received from the encoder, **EncoderDivider** tries to generate a trigger signal calculated from the time the belt was stopped. This will result in no trigger signal being output even after the belt starts moving again.

In this case, by setting the upper limit of the Phase A interval measurement time in **EncoderAveragingInterval**, even if the encoder stops for a long time, the trigger signal can be generated with the setting configured in **EncoderMaxIntervalForNonDecimationMode**.

EncoderDivider Trigger Option

The **EncoderDivider** trigger option allows you to specify the number of triggers to generate as a ratio ($65536 / N$).

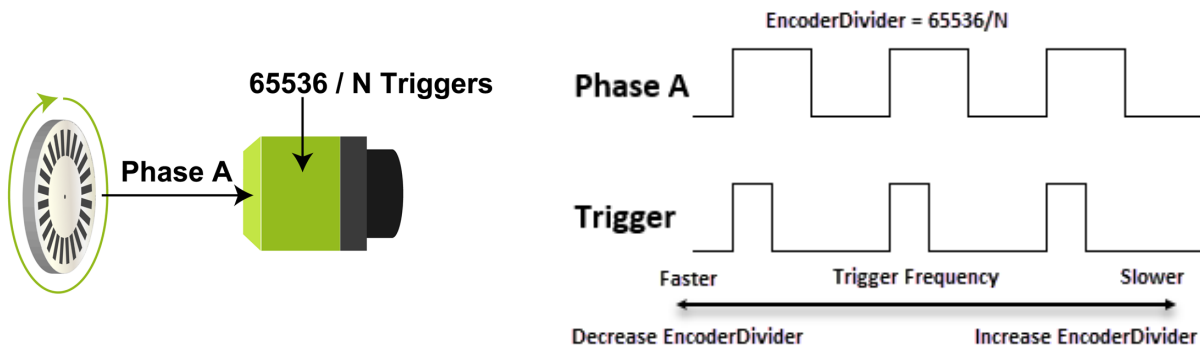

Notes:

- With this setting, input pulses are generated on the rising edge of Phase A.
- **When N is an integer multiple of 65536:** The camera's internal trigger is generated by the decimation of the output trigger of a rotary encoder.

- **When N is not an integer multiple of 65536:** Using the time interval of the output trigger of the rotary encoder, the camera's internal trigger is generated so that the set division ratio is obtained. For example, if the encoder frequency is 10khz, but you need a line rate of 12khz to get a proper image, then the EncoderDivider option can be used to set this 1:1.2 ratio, which will be maintained even if the encoder frequency changes.
- If the time interval of the output of the rotary encoder fluctuates greatly, the output of the camera's internal trigger generated may also fluctuate greatly. In this case, by setting **EncoderAveragingInterval**, it is possible to perform internal processing with the value obtained by averaging the time intervals of the specified number of signals.

EncoderDivider Examples

EncoderDivider Setting	Encoder Input : Encoder Trigger Ratio	Number of Triggers (Output Pulse No.)	Timing Chart
32768	1 : 2	2 (= 65536/32768) The camera generates "two" triggers per a PhaseA input pulse signal.	
65536 (Default)	1 : 1	1 (= 65536/65536) The camera generates "one" trigger per a PhaseA input pulse signal.	
131072	2 : 1	0.5 (= 65536/131072) The camera generates "one" trigger per "two" PhaseA input pulse signals.	

EdgeDetection Trigger Option

The **EdgeDetection** trigger option allows you to specify the number of edges to pass between encoder trigger signals. The number of edges to pass is specified by **EncoderEdgeDetectionPassCount**. This option is useful, for example, if you need to trigger every second or third pulse.

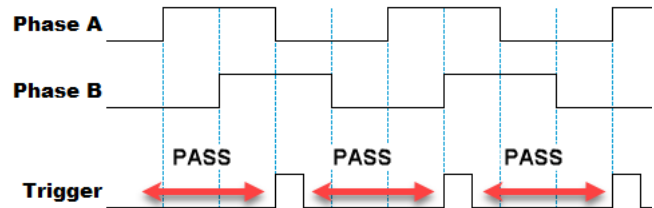
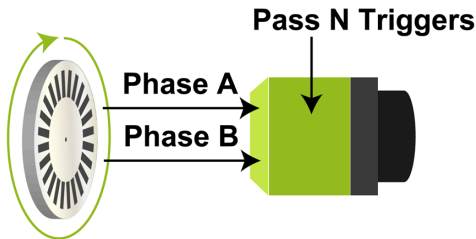

Note: With this setting, input pulses are generated on the rising and falling edge of both Phase A and B. When Phase A - Phase B are exactly 90 degrees apart, the encoder input cycle is 1/4 of Phase A's rising cycle.

EdgeDetection Examples

Edge Detection Pass Count Setting	Description	Timing Chart
0 (Default)	The camera generates "one" trigger per an input pulse signal.	
1	The camera generates "one" trigger per "two" input pulse signals.	
2	The camera generates "one" trigger per "three" input pulse signals.	

Resume Scanning (Backward Counter)

This camera can be configured to stop outputting images when the direction of movement of an object moving on a conveyor belt, etc. is reversed, and to resume outputting images when the object returns to the position where the reversal began. In order for the camera to work in this way, configure the following:

- Configure the camera so that the direction of rotation of the encoder can be determined (see "[Rotation Direction](#)")
- Set **EncoderOutputMode** to **PositionUp** or **PositionDown**.

Example

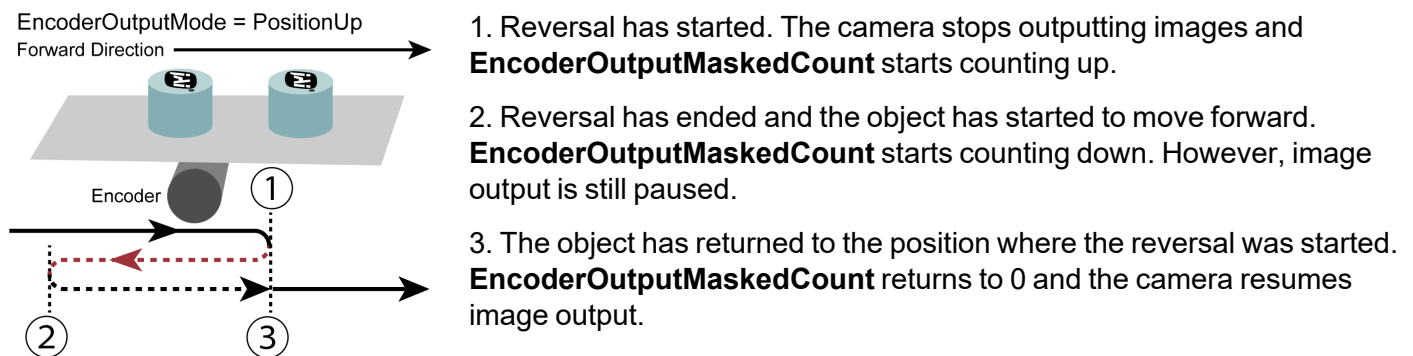

Notes:

- When **AcquisitionStart** [[AcquisitionControl](#)] is executed, **EncoderOutputMaskedCount** is reset to 0.
- If you want to output images while the object is moving in a reverse direction, change the **ObjectDirection** (Forward Direction / Reverse Direction) [[SpatialControl](#)] setting to reverse the detected direction of the object.

Rotation Direction

Incremental encoders typically have two channels (A and B), and the channels operate in a square logical pattern. In one cycle, an encoder outputs a number of pulses on each channel which is called the resolution.

Because the A and B channels are phase shifted, it is possible to determine which direction the rotation is based on which channel is leading (see below).

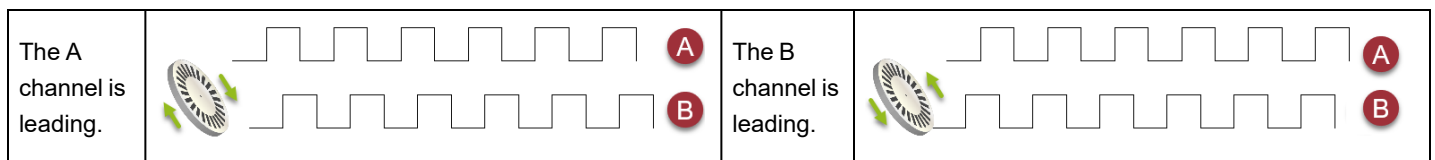

Logic Block Control

Related Topic: [Logic Block Control](#)

This camera supports the Logic Block Control function. A Logic Block is a combinational logic element that conditions various input signal sources by determining true/false and generates output signals accordingly.

This camera supports up to 4 Logic Blocks, and each block has two input sources.

Caution: On this camera, the LogicBlock function is fixed to AND, and the LogicBlock output signal is always inverted; so it acts as a NAND. For example, in the following table, the Logic Block output signal is generated when NAND is 1. If both Input signals are 1, no Logic Block output signal is generated (NAND = 0).

Input0	Input1	AND	NAND
0	0	0	1
0	1	0	1
1	0	0	1
1	1	1	0

How to Configure

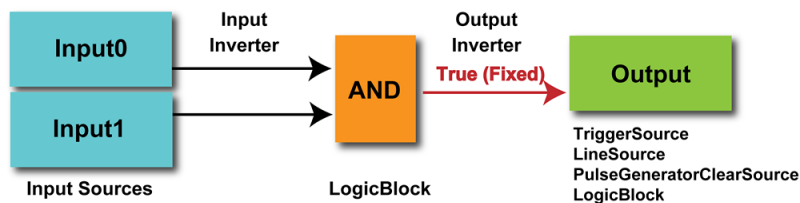

1. Set **LogicBlockSelector** to **LogicBlock0**.
2. Configure LogicBlockInput0. Set **LogicBlockInputSelector** to **0**, and select the Input Source from **LogicBlockInputSource**. If the input source is inverted, set **LogicBlockInputInverter** to **1 (True)**.
3. Configure LogicBlockInput1. Set **LogicBlockInputSelector** to **1**, and select the Input Source from **LogicBlockInputSource**. If the input source is inverted, set **LogicBlockInputInverter** to **1 (True)**.
4. Finally, configure LogicBlock0 as the output signal.

On this camera, the Logic Block can be used as the following signal source: TriggerSource [[AcquisitionControl](#)], LineSource [[DigitalIOControl](#)], PulseGeneratorClearSource [[PulseGenerator](#)], LogicBlock [[Logic Block Control](#)]

Action Control Function

Related Setting Items: [ActionControl](#)



Technical Notes

How to use GigE Vision Action Commands

The Action Control Function is a function that executes the pre-configured action when the camera receives action commands. Action commands can send both unicast and broadcast messages and give instructions for actions to multiple cameras simultaneously by broadcasting them. A camera that has this function can even give instructions for actions to different types of multiple cameras. Although this function includes jitter and delays, it is useful for controlling multiple cameras simultaneously.

Note: When the [PTP \(Precision Time Protocol\)](#) function is turned on, **Scheduled Action Command** (Action Control function) becomes available, which allows you to send Action Commands to multiple cameras synchronized with PTP at the same time. For more information, see the How to use GigEVision Action Commands technical note.

Actions are performed when the following three conditions are met.

1. ActionDeviceKey set to the camera and ActionDeviceKey in the action command match.
2. ActionGroupKey set to the camera and ActionGroupKey in the action command match.
3. ActionGroupMask set to the camera and GroupMask in the action command perform AND operation, and the result is not 0.

How to Configure

1. Specify ActionDeviceKey.
2. Then, specify two actions that can be configured on the camera.

Action 1	<ol style="list-style-type: none"> 1. Select 1 in ActionSelector. 2. Specify ActionGroupMask [ActionSelector]. 3. Specify ActionGroupKey [ActionSelector].
Action2	<ol style="list-style-type: none"> 1. Select 2 in ActionSelector. 2. Specify ActionGroupMask [ActionSelector]. 3. Specify ActionGroupKey [ActionSelector].

3. Set triggers (AcquisitionStart, AcquisitionEnd, FrameStart, AcquisitionTransferStart) to Action1 and Action2.

PTP (Precision Time Protocol)

Related Setting Items: [Transport Layer Control](#)

The camera can work as the slave for Precision Time Protocol defined in IEEE 1588. When the IEEE 1588 master clock exists in the network where the camera is connected, this function synchronizes the camera to the time of the master clock.

- Transport to be used: Multicast UDP datagram (224.0.1.129); however, Delay Resp is a unicast UDP datagram.
- Destination port number:
 - 319 : Sync, Delay Req, Pdelay Req, Pdelay Resp
 - 320 : Announce, Follow Up, Delay Resp, Pdelay Resp, Management, Signaling
- Items for synchronization: Time synchronization is performed. Frequency tuning is not performed.
- PTP time data: 80 bit (elapsed time in 1 ns, with 00:00:00, January 1 1970 set as the origin)
- Timestamp (this camera): 64 bit* (PTP synchronization: LSB64bit* of PTP time data)
- Supported PTP messages: Announce message (receive only), Sync message (receive only), Follow Up message (receive only), Delay Req message (send only), Delay Resp message (receive only)

Cautions:

- The Timestamp Tick Frequency register value is fixed at 1,000,000,000 (1 GHz).
- When PTP synchronization is being performed, the Timestamp Reset function is disabled.
- Because GenICam treats the timestamp (64 bit) as a 64 bit signed integer, 63 bit is actually timestamp data without the sign bit.

How To Configure

1. Set **GevIEEE1588** ([Transport Layer Control](#)) to **True**.
2. After several statuses from Disable, when a Sync Message is received from the PTP server, **Slave** is Displayed in **GevIEEE1588 Status**.

Note: When the PTP function is **On**, you can use Scheduled Action Command ([ActionControl](#)), which allows you to send action commands to multiple cameras synchronized with PTP at the same time.

Chunk Data Function

Related Setting Items: [ChunkDataControl](#)

The Chunk Data function adds camera configuration information to the image data that is output from the camera. In addition, when images are acquired with a single camera in sequence under multiple setting conditions, you can search for images by their setting conditions.

Configuring Chunk Data

1. Set **ChunkModeActive** to **True**. (Default = False)
2. Selects which Chunk to enable or control in **ChunkSelector**.
3. Set **ChunkEnable** to **True**. (Default = False)

Caution: The Chunk Data function settings cannot be changed during image output. To change the settings, stop Acquisition.

Event Control Function

Related Setting Items: [EventControl](#)

The Event Control function is a function that outputs a signal change point inside the camera as information indicative of an event occurrence (event message).

Flow from Detecting an Event to Sending an Event Message

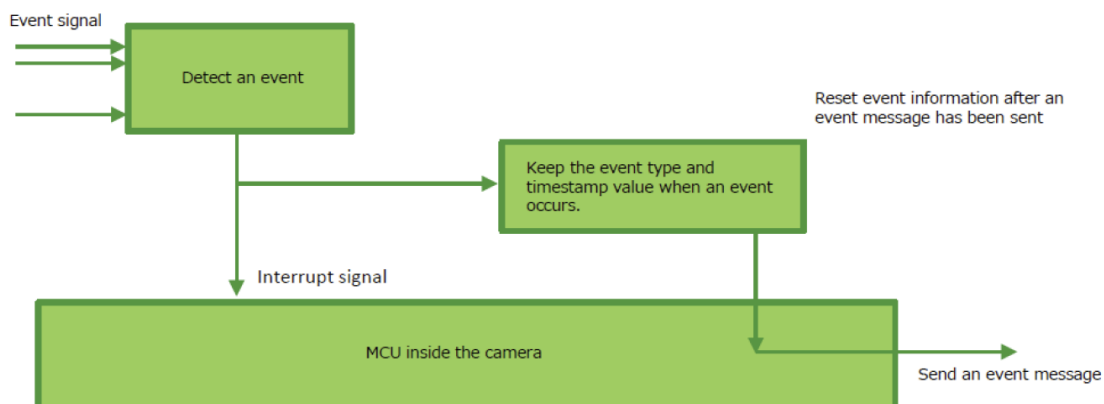

How to Configure

1. Select the even you want to configure from **EventSelector**.
2. Set **EventNotification** to **On**.
3. When an enabled Event occurs, the following Event data will be sent: **EvenID**, **EventTimeStamp**, **EventFrameID**.

For example, when **AcquisitionStart** is selected from **EventSelector** and **EventNotification** is set to **On**, the following message will be sent when an Acquisition Start trigger occurs.

EventAcquisitionStartData	Display the following data when the enabled Event occurs.
EventAcquisitionStart	Display the EventID 0x9011.
EventAcquisitionStartTimestamp	Display the time stamp value when the enabled Event occurs.
EventAcquisitionStartFrameID	Display the FrameID value when the enabled Event occurs.

Caution: This camera has the following limitations when Event(s) other than AcquisitionStart / AcquisitionStop are enabled (there are no limitations when only AcquisitionStart and/or AcquisitionStop Event are enabled).

- The line rate limitations when Event(s) other than AcquisitionStart / AcquisitionStop event are enabled are as follows.

Number of enabled events other than AcquisitionStart / AcquisitionStop	Max Line Rate
1	6kHz
2	4kHz

- JAI does not recommend enabling more than three Events other than the AcquisitionStart and/or AcquisitionStop Events.

Setting List (Feature Properties)

This camera complies with GenICam. Each setting item name conforms to GenICam SFNC (Standard Features Naming Convention). (There are some JAI-specific setting items).

Each setting item is an integer type (Integer), a real type (Float), an element enumeration type (Enumeration), a character string (String), a logical type (Boolean), and a category type (Category) or a command type (Command) for executing the function.

Beginner: For beginner users.

Expert: For users with deep knowledge of camera functions.

Guru: For advanced users who make settings, including advanced features that can cause the camera to malfunction if not set correctly.

■ Selector

A Selector is used to index which instance of the feature is accessed in situations where multiple instances of a feature exist.

■ Instance Example:

Each Line-related item (LineSource, LineInverter, etc.) has LineSelector-LineX instances, which can be set or referenced as an index.

Selectors are a feature of element enumeration type (Enumeration) or an integer type (Integer). However, unlike normal configuration items, it is only used to select the instance in the following configuration item.

It does not change the behavior of the camera by changing the value of the selector. Also, the selector may have only one selectable value. In this case, use the selector function only for information purposes. In this document, it is described as SelectedFeature[Selector] according to the description method of GenICam.

In the case of Line Selector with a specific I/O line selected, the description could be as follows.

LineSource[LineSelector-LineX] = High

LineInverter[LineSelector-LineX] = False

LineMode[LineSelector-LineX] = Input

LineFormat[LineSelector-LineX] = TTL

Generally, selectors only apply to a single category of features. (Example: TriggerSelector only applies to trigger related functions.)

DeviceControl

Display/configure information related to the device.

DeviceControl Item	Setting Range	Default	Description
DeviceScanType	-	1: Line Scan	Display the device's scan type.
DeviceVendorName	-	"JAI Corporation"	Display the manufacturer name.
DeviceModelName	-	SW-2005TL-5GE SW-2005M-5GE SW-4005BL-5GE SW-4005M-5GE	Display the model name.
DeviceManufacturerInfo	-	See the possibilities	Display manufacturer information.
DeviceVersion	-	-	Display the software version.
DeviceFirmwareVersion	-	-	Display the firmware version.
DeviceFpgaVersion	-	FPGA Ver. No.	Display the FPGA version.
DeviceSerialNumber	-	-	Display the device serial number.
DeviceUserID	Any	-	Set the user ID for the camera.
DeviceSFNCVersion Major	-	SFNCMajorVersion	Display the SFNC version.
DeviceSFNCVersion Minor	-	SFNCMajorVersion	Display the SFNC version.
DeviceSFNCVersion SubMinor	-	SFNCSUBMinorVersion	Display the SFNC version.
DeviceManifestEntrySelector	1: XML1	1: XML1	Selects the manifest entry to reference. (Fixed to XML1)
DeviceManifestXML MajorVersion	-	-	Indicates the major version number of the XML file of the selected manifest entry.
DeviceManifestXML MinorVersion	-	-	Indicates the minor version number of the XML file of the selected manifest entry.
Device Manifest XML SubMinor Version	-	-	Indicates the subminor version number of the XML file of the selected manifest entry.
DeviceManifestSchema MajorVersion	-	-	Indicates the major version number of the schema file of the selected manifest entry.
DeviceManifestSchema MinorVersion	-	-	Indicates the minor version number of the schema file of the selected manifest entry.
DeviceManifest PrimaryURL	-	-	Display the PrimaryURL.

DeviceControl Item	Setting Range	Default	Description
DeviceManifest SecondaryURL	-	-	Display the SecondaryURL.
DeviceTLType	-	0: GigEVision	Display the Transport Layer type of the device.
DeviceTLVersionMajor	-	2	Display the major version number of the Transport Layer type.
DeviceTLVersionMinor	-	0	Display the minor version number of the Transport Layer type.
DeviceTLVersionSubMinor	-	0	Display the sub minor version number of the Transport Layer type.
DeviceLinkSelector	-	-	Select I/F for control. (fixed to 0)
DeviceLinkSpeed	0 ~ 536870911875000	625000000 Bps	Displays the negotiated transmission rate.
DeviceLink HeartbeatMode	0: Off 1: On	1: On	Display whether Heartbeat mode is enabled/disabled.
DeviceLink HeartbeatTimeout (us)	500000 ~ 1.2e+08	5e+06	Configure the timeout value for Heartbeat (unit: μs). Step: 1000
DeviceStreamChannel Count	-	1	Display the number of supported stream channels.
DeviceEventChannel Count	-	1	Display the number of supported message channels.
Device Reset	-	-	Reset the device.
Device Registers Endianness	-	1: Big	Endianness of the registers of the device.
Device Temperature (°C)	- 55 ~ 125	-	Display the internal temperature (°C) of the camera.
Timestamp	0 ~ 64-bit max (ns)	-	Display the timestamp value (ns). Resets to 0 when the signed maximum 64-bit value is exceeded.
TimestampReset	-	-	Forcibly sets the timestamp's count value to 0.
TimestampLatch	-	-	Sets the timestamp's count value to TimestampLatchValue.
TimestampLatchValue	0 ~ 64bit max (ns)		Returns the latched value of the timestamp counter.
UserDefinedValueSelector	0: Value1 1: Value2 2: Value3 3: Value4 4: Value5	0: Value1	32bit data x 5 can be set and saved.
UserDefinedValue	-2147483648 ~ 2147483647	0	Read and set the value for the 32-bit data (Value 1 to Value5) selected in UserDefinedValueSelector.

Transport Layer Control

Configure Transport Layer settings.

Transport Layer Control Item	Setting Range	Default	Description
PayloadSize	48 ~ 67109240	-	Display the payload size information. (Default) SW-2005M-5GE: 2048 SW-2005TL-5GE: 6144 SW-4005M-5GE: 4096 SW-4005BL-5GE: 12288
GigEVision			
GevPhysicalLinkConfiguration	-	SingleLink (Fixed)	Display the LinkConfiguration status.
GevSupportedOption Selector	Select the supported options for GigEVision. The selections are as follows:		
	Link Configuration	SingleLink, MultiLink, StaticLAG, DynamicLAG	
	nif Configuration	PAUSEFrameReception, PAUSEFrameGeneration, IPConfigurationLLA, IPConfigurationDHCP, IPConfigurationPersistentIP	
	GVCP	MessageChannelSourceSocket, CommandsConcatenation, WriteMem, PacketResend, Event, EventData, PendingAck, IEEE1588, Action, UnconditionalAction, ScheduledAction, PrimaryApplicationSwitchover, ExtendedStatusCodes, ExtendedStatusCodesVersion2_0, DiscoveryAckDelay, DiscoveryAckDelayWritable, TestData, ManifestTable, CCPApplicationSocket, LinkSpeed, HeartbeatDisable, SerialNumber, UserDefinedName	
GVSP	StreamChannelSourceSocket, StandardIDMode, StreamChannelBigAndLittleEndian, StreamChannelIPReassembly, StreamChannelMultiZone, StreamChannelPacketResendDestination, StreamChannelAllInTransmission, StreamChannelUnconditionalStreaming, StreamChannelExtendedChunkData		
GevSupportedOption	0: False 1: True	-	Displays whether the function selected by GevSupportOptionSelector is supported or not.
GevInterfaceSelector	-	0 (Fixed)	Selects which logical link to control.
GevMacAddress	-	-	Display the MAC address.
GevPAUSEFrameReception	0: False 1: True	True	Controls whether incoming PAUSE Frames are handled on the given logical link.
GevPAUSEFrameTransmission	0: False 1: True	True	Controls whether PAUSE Frames can be generated on the given logical link.

Transport Layer Control Item	Setting Range	Default	Description
GevCurrentIPConfiguration LLA		True (Fixed)	Display whether the current IP configuration is calibrated by LLA (link-local address).
GevCurrentIPConfiguration DHCP	0: False 1: True	True	Select whether to set the IP configuration to DHCP.
GevCurrentIPConfiguration PersistentIP	0: False 1: True	False	Select whether to set the IP configuration to Persistent IP.
GevCurrentIPAddress	-	-	Display the IP address.
GevCurrentSubnetMask	-	-	Display the subnet.
GevCurrentDefaultGateway	-	-	Display the default gateway.
GevIPConfigurationStatus	0: None 1: PersistentIP 2: DHCP 3: LLA 4: ForceIP	LLA	Display the current IP configuration status.
GevPersistentIPAddress	0.0.0.0 ~ 255.255.255.255		Set the persistent IP address.
GevCurrentSubnetMask			Set the persistent subnet mask.
GevPersistentDefaultGateway			Set the persistent default gateway.
NetworkThroughput SafetyMargin	10 ~ 100	92	For the configured LinkSpeed, set the limit to the bandwidth of the stream out of the camera (%). Caution: You can increase the frame rate by increasing this value. However, when set to more than 92 (default), abnormal images may be observed depending on the PC and its environment. If this happens, set the value to the default value (92).
GevIEEE1588 Related Topic: PTP (Precision Time Protocol)	0: False 1: True	False	TRUE : Enables PTP FALSE: Disables PTP

Transport Layer Control Item	Setting Range	Default	Description
GevIEEE1588ClockAccuracy	0 ~ 20	Unknown	Indicates clock accuracy. 0:Within25ns, 1:Within100ns, 2:Within250ns, 3:Within1us, 4:Within2p5u, 5:Within10us, 6:Within25us, 7:Within100us, 8:Within250us, 9:Within1ms. 10:Within2p5ms, 11:Within10ms, 12:Within25ms, 13:Within100ms, 14:Within250ms, 15:Within1s, 16:Within10s, 17:GreaterThan10s, 18:AlternatePTPProfile, 19:Unknown, 20:Reserved
GevIEEE1588Status	-	Disabled	Display the IEEE 1588 Status. 1: Initializing, 2: Faulty, 3: Disabled, 4: Listening, 5: PreMaster, 6: Master, 7: Passive, 8: Uncalibrated, 9: Slave
GevGVCPEExtendedStatusCodesSelector	0:Version1_1 1:Version2_0	Version1_1	Select the GevGVCPEExtendedStatusCodes.
GevGVCPEExtendedStatusCodes	0: False 1: True	False	Enables the generation of extended status codes.
GevGVCPPendingAck	0: False 1: True	False	Enables/disables the PENDING_ACK.
GevGVSPExtendedIDMode	0: Off 1: On	On	Enables/disables Extended ID Mode.
GevCCP	0: OpenAccess 1: ExclusiveAccess 2: ControlAccess	0: OpenAccess	Control access rights. 0: OpenAccess - Access rights have not been obtained by the application. 1: ExclusiveAccess - Once the application has made this setting, no other applications can control or reference the camera. 2: ControlAccess - Access rights have been obtained by the application. Other applications cannot control the camera, but can refer to it.
GevPrimaryApplicationSocket	-	-	Returns the UDP source port of the primary application.
GevPrimaryApplicationIPAddress	-	-	Returns the address of the primary application.
GevMCPHostPort	-	-	Controls the port to which the device must send messages. Setting this value to 0 closes the message channel.
GevMCDA	-	-	Controls the destination IP address for the message channel.

Transport Layer Control Item	Setting Range	Default	Description
GevMCTT	0 ~ 4294967295	400	Display/set the Transmission Timeout for Message Channel.
GevMCRC	0 ~ 4294967295	3	Display/set the Retry Count for Message Channel.
GevMCSP	-	-	This feature indicates the source port for the message channel.
GevStreamChannelSelector	-	0 (Fixed)	Selects the stream channel to control.
GevSCCFGPacket ResendDestination	0: False 1: True	False	Enables the alternate IP destination for stream packets resent due to a packet resend request.
GevSCCFGAllInTransmission	0: False 1: True	False	Enables the selected GVSP transmitter to use the single packet per data block All-in Transmission mode.
GevSCCFGUnconditional Streaming	0: False 1: True	False	Enables the camera to continue to stream, for this stream channel, if its control channel is closed or regardless of the reception of any ICMP messages (such as destination unreachable messages).
GevSCCFGExtended ChunkData	0: False 1: True	False	Enables cameras to use the extended chunk data payload type for this stream channel.
GevSCPIInterfaceIndex	-	0 (Fixed)	Index of the logical link to use.
GevSCPHostPort	-	-	Controls the port to which the device must send messages.
GevSCPSFireTestPacket	0: False 1: True	True	Sends a test packet.
GevSCPSDoNotFragment	0: False 1: True	True	The state of this feature is copied into the "do not fragment" bit of IP header of each stream packet. It can be used by the application to prevent IP fragmentation of packets on the stream channel.
GevSCPSPacketSize (byte)	1476 ~ 8192	1476	This GigE Vision specific feature corresponds to DeviceStreamChannelPacketSize and should be kept in sync with it. It specifies the stream packet size, in bytes, to send on the selected channel for a GVSP transmitter or specifies the maximum packet size supported by a GVSP receiver.
GevSCPD	0 ~	0	Controls the delay (in GEV timestamp counter unit) to insert between each packet for this stream channel. The maximum value varies depending on the settings.

Transport Layer Control Item	Setting Range	Default	Description
GevSCDA	-	-	Controls the destination IP address of the selected stream channel to which a GVSP transmitter must send data stream or the destination IP address from which a GVSP receiver may receive data stream.
GevSCSP	-	-	Indicates the source port of the stream channel.

ImageFormatControl

Configure image format settings.

Image Format Control Item	Setting Range	Default	Description
SensorWidth	SW-2005M-5GE: 2048 SW-2005TL-5GE: 2048 SW-4005M-5GE: 4096 SW-4005BL-5GE: 4096		Display the maximum image width.
WidthMax	SW-2005M-5GE: 2048 (1024) SW-2005TL-5GE: 2048 (1024) SW-4005M-5GE: 4096 (2048) SW-4005BL-5GE: 4096 (2048) (): BinningHorizontal = 2		Display the maximum image width.
HeightMax	-	4096	Display the maximum image height.
Width	128 (64)* ~ [WidthMax - OffsetX], Step: 8 (8) (): BinningHorizontal = 2	WidthMax	Set the image width.
Height	1 ~ [HeightMax], Step: 1	1	Set the image height (= number of lines).
OffsetX	0 ~ [WidthMax - Width], Step: 8 (8) (): BinningHorizontal = 2	0	Set the horizontal offset.
OffsetY	0 ~ [HeightMax - Height], step 1	0	Set the vertical offset.
BinningHorizontalMode	0: Sum 1: Average	0: Sum	Set the processing method for horizontal binning.

Image Format Control Item	Setting Range	Default	Description
BinningHorizontal	1: Off 2: On	1: Off	Set the number of pixels in the horizontal direction for which to perform binning.
ReverseX Related Topic: Image Flip Function (ReverseX)	0: Off 1: On	0: Off	Reverse pixels horizontally.
PixelFormat Color Model	SW-2005TL-5GE: 0x02180014: RGB8 (Default) 0x0220001C: RGB10V1Packed 0x0220001D: RGB10p32 0x02240034 : RGB12V1Packed SW-4005BL-5GE 0x02180014: RGB8 (Default) 0x0220001C: RGB10V1Packed 0x0220001D: RGB10p32 0x02240034 : RGB12V1Packed 0x021000A5: BiColorRGBG8 0x022000A7: BiColorRGBG10 0x022000AB: BiColorRGBG12 0x021000A6: BiColorBGRG8* 0x022000A9: BiColorBGRG10* 0x022000AD: BiColorBGRG12* 0x021400A8: BiColorRGBG10p 0x021800AC: BiColorRGBG12p 0x021400AA: BiColorBGRG10p* 0x021800AE: BiColorBGRG12p*		Set the Pixel Format. Note: *When ReverseX = On
PixelFormat Monochrome Model	SW-2005M-5GE, SW-4005M-5GE 0x01080001: Mono8 (Default) 0x01100003: Mono10 0x01100005: Mono12 0x010C0004: Mono10Packed 0x010C0006: Mono12Packed		Set the Pixel Format.

Image Format Control Item	Setting Range	Default	Description
PixelSize Color Model	SW-2005TL-5GE RGB8: Bpp24 (Default) RGB10V1Packed: Bpp32 RGB10p32: Bpp32 RGB12V1Packed: Bpp36 SW-4005BL-5GE RGB8: Bpp24 (Default) RGB10V1Packed: Bpp32 RGB10p32: Bpp32 RGB12V1Packed: Bpp36 BiColorRGBG8: Bpp16 BiColorRGBG10: Bpp32 BiColorRGBG12: Bpp32 BiColorRGBG10p: Bpp20 BiColorRGBG12p: Bpp24		Display the total pixel size of the output image in bits.
PixelSize Monochrome Model	SW-2005M-5GE SW-4005M-5GE Mono8: Bpp8 (Default) Mono10: Bpp16 Mono12: Bpp16 Mono10Packed: Bpp12 Mono12Packed: Bpp12		Display the total pixel size of the output image in bits.
Test Pattern	0: Off 1: White 2: GreyPattern1 (Ramp) 3: GreyPattern2 (Stripe) 4: ColorBar (Color model only)	0: Off	Select the type of test pattern that is generated by the device as image source.

AcquisitionControl

Related Topic: [Acquisition Control](#)

Configure image capture settings.

Acquisition Control Item	Setting Range	Default	Description
AcquisitionMode Related Topic: Acquisition Control	0: SingleFrame 1: MultiFrame 2: Continuous (Default)		Select the image capture mode.
AcquisitionStart	-	-	Start image capture.
AcquisitionStop	-	-	Stop image capture.
AcquisitionFrameCount	1 ~ 65535	1	In MultiFrame mode, set the number of frames to capture.
AcquisitionFrameRate (Hz)	66 Hz ~	-	Display the frame rate as a frequency. (unit: Hz) (Step: 0.1) FrameRate = LineRate/Height
AcquisitionLineRate (Hz) Related Topic: Change the Line Rate	66 Hz ~ (step: 0.01)	-	Set the AcquisitionLineRate (Hz). The maximum value varies depending on the PixelFormat and ROI settings. See Maximum Line Rates (Approximate) for the maximum acquisition late value under different settings.
TriggerSelector Related Topic: Trigger Control	0: AcquisitionStart 1: AcquisitionEnd 2: LineStart 3: FrameStart 4: AcquisitionTransferStart		Select the trigger operation.
TriggerMode	0: Off 1: On	0: Off	Enables/Disables the Trigger mode.
TriggerSoftware	-	-	Execute a software trigger.

Acquisition Control Item	Setting Range	Default	Description
TriggerSource	7-10: PulseGenerator0-3 11-14: UserOutput0-3 15-18: Action0-3 19: Software 23: Line4 TTL In1 (Default) 24: Line5 Opt In1 33: Line14 TTL In4 36-39: Logic Block0-3 40: EncoderTrigger		Select the trigger signal source.
TriggerActivation	0: RisingEdge (Default) 1: FalingEdge 2: LevelHigh 3: LevelLow		Select the polarity of the trigger signal (i.e., location of signal at which trigger is applied).
ImageOutputDelay	0 ~ 65535 (1Line / Step)	0	Set the number of lines between the AcquisitionStart trigger input and the time when image data is output to the host. Note: Only enabled when TriggerSelector = AcquisitionStart when TriggerMode is On.
Exposure Mode	0: Off 1: Timed (Default) 2: Trigger Width		Select the exposure mode.
ExposureTimeMode	0: Common (Default) 1: Individual*		When set to Individual, ExposureTime can be adjusted for RGB individually. Note: *Individual: TL model Only
ExposureTimeSelector	0: Common (Default) 1: Red* 2: Green* 3: Blue*		Selects which exposure time is controlled by the ExposureTime feature. Note: *Red, Green, Blue: TL model Only

Acquisition Control Item	Setting Range	Default	Description										
Exposure Time (μs) Related Topic: Actual Exposure Time	0.11μs ~ (step: 0.01)	-	Set the exposure time for the channel selected in ExposureTimeSelector. The maximum time vary depending on the settings. For the exposure time information on each setting, see " Specifications ". Exposure Offset Time Duration <table border="1"> <thead> <tr> <th>Model</th> <th>Offset Time Duration</th> </tr> </thead> <tbody> <tr> <td>SW-2005TL-5GE</td> <td>3.11μs</td> </tr> <tr> <td>SW-2005M-5GE</td> <td>1.54μs</td> </tr> <tr> <td>SW-4005BL-5GE</td> <td>3.11μs</td> </tr> <tr> <td>SW-4005M-5GE</td> <td>2.06μs</td> </tr> </tbody> </table>	Model	Offset Time Duration	SW-2005TL-5GE	3.11μs	SW-2005M-5GE	1.54μs	SW-4005BL-5GE	3.11μs	SW-4005M-5GE	2.06μs
Model	Offset Time Duration												
SW-2005TL-5GE	3.11μs												
SW-2005M-5GE	1.54μs												
SW-4005BL-5GE	3.11μs												
SW-4005M-5GE	2.06μs												
ExposureModeOption Related Topic: Exposure Mode	0: PrioritizeExposureTime (Default) 1: PrioritizeLineRate		Specifies whether to prioritize exposure time (PrioritizeExposureTime) or line rate (PrioritizeLineRate) when controlling line rate and exposure.										

DigitalIOControl

Related Topic: [GPIO \(Digital Input/Output Settings\)](#)

Configure settings for digital input/output.

Digital IO Control Item	Setting Range	Default	Description												
LineSelector	20: Line1 TTL Out1 (Default) 23: Line4 TTL In1 24: Line5 Opt In1 31: Line12 TTL Out4 33: Line14 TTL In4		Select the input/ output to configure.												
LineMode	0: Input 1: Output		Display the input/ output status (whether it is input or output). <table border="1"> <thead> <tr> <th>LineSelector</th> <th>Input or Output</th> </tr> </thead> <tbody> <tr> <td>20: Line1 TTL Out1 (Default)</td> <td>Output</td> </tr> <tr> <td>23: Line4 TTL In1</td> <td>Input</td> </tr> <tr> <td>24: Line5 Opt In1</td> <td>Input</td> </tr> <tr> <td>31: Line12 TTL Out4</td> <td>Output</td> </tr> <tr> <td>33: Line14 TTL In4</td> <td>Input</td> </tr> </tbody> </table>	LineSelector	Input or Output	20: Line1 TTL Out1 (Default)	Output	23: Line4 TTL In1	Input	24: Line5 Opt In1	Input	31: Line12 TTL Out4	Output	33: Line14 TTL In4	Input
LineSelector	Input or Output														
20: Line1 TTL Out1 (Default)	Output														
23: Line4 TTL In1	Input														
24: Line5 Opt In1	Input														
31: Line12 TTL Out4	Output														
33: Line14 TTL In4	Input														
Line Inverter	0: False 1: True	False	Enable/disable polarity inversion for the selected input signal or output signal.												

Digital IO Control Item	Setting Range	Default	Description
Line Status	0: False (Low) (Default) 1: True (High)		Display the status of the input signal or output signal (True: High, False: Low).
LineStatusAll	bit0: Line1 (Default) bit1 ~ 2: Unused bit3: Line4 bit4: Line5 bit5: Unused bit10: Unused bit11: Line12 bit13: Line14 bit14 ~ 15: Unused		Display the input/output signal status. Note: Unused = (Fixed) to 0
LineSource Related Topic: LineSource Items	1: AcquisitionActive 2: FrameActive 4: ExposureActive 6: LVAL 7: PulseGenerator0 8: PulseGenerator1 9: PulseGenerator2 10: PulseGenerator3 11: UserOutput0 12: UserOutput1 13: UserOutput2 14: UserOutput3 23: Line4 TTL In1 (Default) 24: Line5 Opt In1 33: Line14 TTL In4 36: Logic Block0 37: Logic Block1 38: Logic Block2 39: Logic Block3 40: EncoderTrigger 41: Encoder Direction		Select the line source signal for the item selected in Line Selector. The following is fixed to "-": 23: Line4 TTL In1 24: Line5 Opt In1
Line Format	2: TTL 5: OptoCoupled		Display the current I/O type. Default: 24: Line5 Opt In1 = OptoCoupled Other = TTL
OptoInFilter (ns)	0 ~ 1000000	0	Select the period for filtering mask of the Opt-In signal.

Digital IO Control Item	Setting Range	Default	Description
User Output Selector	0: User Output 0 (Default) 1: User Output 1 2: User Output 2 3: User Output 3		Set the user output signal.
User Output Value	0: False (Low) (Default) 1: True (High)		Set the User Output value selected in User Output Selector.
ExposureActiveSource Related Topic: ExposureActive Signal	0: Common (Default) 1: Red 2: Green 3: Blue		Select the channel for the ExposureActive signal when LineSource is set to ExposureActive. When set to Common , the channel with the longest exposure time is output as the ExposureActive signal. Note: TL model Only

PulseGenerator

Related Topic: [Pulse Generator](#)

Configure pulse generator settings.

Pulse Generators Item	Setting Range	Default	Description
ClockPre-scaler	1~ 4096	1	Set the division value for the prescaler (12-bit) using the pixel clock as the base clock.
PulseGeneratorClock (MHz)	$\text{PulseGeneratorClock} = 100 / \text{ClockPreScaler}$	100	Set the clock used for the pulse generator. This value is calculated based on the Clock Pre-Scaler value.
Pulse Generator Selector	0: PulseGenerator0 (Default) 1: PulseGenerator1 2: PulseGenerator2 3: PulseGenerator3		Select the pulse generator.
PulseGeneratorLength Value	1 ~ 1048575	30000	Set the maximum count up value using clock value.
PulseGeneratorLength (ms)	$\text{PulseGeneratorLength} = 1 / \text{PulseGeneratorClock} * \text{PulseGeneratorLengthValue}$	0.3	Set the maximum count up value using ms. This value is calculated based on the Pulse Generator Length value. The setting range varies depending on the Clock Pre-Scaler value.
PulseGeneratorFrequency (Hz)	$\text{PulseGeneratorFrequency} = 1\text{sec} / \text{PulseGeneratorLength}$	3333.3333	Set the maximum count up value using frequency. This value is calculated based on the Pulse Generator Length value.
PulseGeneratorStartPoint Value	0 ~ 1048574	0	Set the start point for the High interval using clock value. When the counter reaches this value, the output becomes 1.
PulseGeneratorStartPoint (ms)	$\text{PulseGeneratorStartPoint} = 1 / \text{PulseGeneratorClock} * \text{PulseGeneratorStartPointValue}$	0	Set the start point for the High interval using ms. When the counter reaches this value, the output becomes 1. The setting range varies depending on the Clock Pre-Scaler value.
PulseGeneratorEndPoint Value	1 ~ 1048575	15000	Set the start point for the Low interval using clock value. When the counter reaches this value, the output becomes 0.
PulseGeneratorEndPoint (ms)	$\text{PulseGeneratorEndPoint} = 1 / \text{PulseGeneratorClock} * \text{PulseGeneratorEndPointValue}$	0.15	Set the start point for the Low interval using ms. When the counter reaches this value, the output becomes 0. The setting range varies depending on the Clock Pre-Scaler value.

Pulse Generators Item	Setting Range	Default	Description
PulseGeneratorPulseWidth (ms)	PulseGeneratorPulseWidth = 1/PulseGeneratorClock * (PulseGeneratorEndPointValue - PulseGeneratorStartPointValue)	0.15	Display High interval width for the pulse in ms. This is a calculation of the time between the Start Point and End Point. The setting range varies depending on the Clock Pre-Scaler value.
PulseGeneratorRepeat Count	0 ~ 255	0	Set the repeat count for the counter. When this is set to 0, the counter will be free-running with limitless repeating.
PulseGeneratorClear Activation	0: Off 1: LevelHigh 2: LevelLow 3: RisingEdge 4: FallingEdge	0: Off	Set the clear signal condition for the count clear input of the pulse generator.
PulseGeneratorClear Source	4: ExposureActive 6: LVAL 7-10: PulseGenerator0-3 11-14: UserOutput0-3 23: Line4 TTL In1 (Default) 24: Line5 Opt In1 33: Line14 TTL In4 36-39: Logic Block0-3 40: EncoderTrigger		Select the count clear input signal source.
PulseGeneratorClear SyncMode	0: Async Mode (Default) 1: Sync Mode		Select the sync mode for the count clear input signal.

AnalogControl

Configure analog control settings.

Note: Items with "*" are only supported on the color model.

Analog Control Item	Setting Range	Default	Description
IndividualGainMode* Related Topic: Gain Control	0: Off 1: On	0: Off	In IndividualGainMode, RGB can be configured individually for the entire gain adjustment range of the sensor.
InGainBypassMode	0: Off 1: On	0: Off	When On , disable the camera's internal fixed gain (= InGain) and only enable the user-set gain. Note: For the color model, this setting is enabled only when IndividualGainMode is set to On .
SensorGainMode Related Topic: Sensor Gain Mode	0: LowGainMode (Default) 1: HighGainMode		Configure the sensor's gain mode. LowGainMode (default) provides images with reduced noise but requires a brighter lighting environment due to lower sensitivity. HighGainMode increases sensitivity and allows imaging in low-light conditions, but the noise level will be higher. Note: This function is supported on the SW-2005 models that operate with firmware version DV0103 or later.
GainSelector*	0: Digital All (Individual Gain Mode = OFF Only) (Default) 1: Digital Red 2: Digital Green (Individual Gain Mode = ON Only) 3: Digital Blue		Select the gain to configure. Note: When IndividualGaiMode is set to Off, DigitalGreen's Gain value is fixed to "1".

Analog Control Item	Setting Range	Default	Description											
Gain	-	-	<p>Set the gain value for the gain item selected with the GainSelector setting (Unit: times, step:0.01, default = 1.00).</p> <table border="1"> <thead> <tr> <th>Model</th> <th>Individual GainMode</th> <th>Range</th> </tr> </thead> <tbody> <tr> <td rowspan="2">Color</td> <td>Off</td> <td>DigitalAll: 1.00 ~ 32.00 DigitalRed/Blue: 0.40 ~ 4.00</td> </tr> <tr> <td>On</td> <td>DigitalRed/Green/Blue: 1.00 ~ 64.00</td> </tr> <tr> <td>Mono</td> <td>-</td> <td>1.00 ~ 64.00</td> </tr> </tbody> </table>	Model	Individual GainMode	Range	Color	Off	DigitalAll: 1.00 ~ 32.00 DigitalRed/Blue: 0.40 ~ 4.00	On	DigitalRed/Green/Blue: 1.00 ~ 64.00	Mono	-	1.00 ~ 64.00
Model	Individual GainMode	Range												
Color	Off	DigitalAll: 1.00 ~ 32.00 DigitalRed/Blue: 0.40 ~ 4.00												
	On	DigitalRed/Green/Blue: 1.00 ~ 64.00												
Mono	-	1.00 ~ 64.00												
GainAuto	0: Off (Default) 1: Once		<p>Enable/disable gain auto adjustment. Once automatically changes to Off when the signal level converges once.</p> <p>Note: GainAuto can only be use when IndividualGainMode = Off.</p>											
GainAutoWidth	-	-	The same setting range as Width [ImageFormatControl].											
GainAutoOffsetX	-	-	The same setting range as OffsetX [ImageFormatControl].											
AGCReference	30 ~ 95 %	50	Set the target level for GainAuto in percentage.											
AGCOnceStatus	0: Idle (Default) 1: Processing 3: Succeeded 7: Error3 - Timeout 8: Error4 - could not processing		Display the GainAuto status. For more information, see " Adjust the Gain ".											
BlackLevelSelector	0: All (Default) 1: Red* 2: Blue*		Select the black level to configure.											
BlackLevel	All:-133 ~ 255 Red*:-64 ~ 64 Blue*:-64 ~ 64 Default: 0 for all options		Set the black level value.											
BalanceWhiteAuto*	0: Off (Default) 1: Once 2: Once User Area BE 3: Preset 500K 4: Preset 6500K 5: Preset7500K		<p>Enable/disable auto white balance. When using a Color Temperature option (Preset 500K, Preset6500K, or Preset7500K) , IndividualGainMode [AnalogControl] must be set to Off.</p>											

Analog Control Item	Setting Range	Default	Description
BalanceWhiteAutoWidth*	-	-	The same setting range as Width [ImageFormatControl] .
BalanceWhiteAutoOffsetX*	-	0	The same setting range as OffsetX [ImageFormatControl].
BalanceWhiteAutoResult*	-	-	Display the BalanceWhiteAuto result. For more information, see " Adjust the White Balance ". 0: Idle (Default) 1: Processing 3: Succeeded 4: Succeeded with BE condition 5: Error1 - G image was too bright 6: Error2 - G image was too dark 7: Error3 - Timeout 8: Error4 - Target level was too high 9: Error5 - Target level was too low
Gamma Related Topic: Gamma Function	0.45 (Default), 0.5, 0.55, 0.6, 0.65, 0.75, 0.8, 0.9, 1.0		Set the gamma value.
LUT Mode	0: Off (Default) 1: Gamma 2: LUT		Select the JAI LUT mode.

LUT Control

Related Topic: [LUT \(Lookup Table\)](#)

Configure LUT settings.

LUT Control Item	Setting Range	Default	Description
LUT Selector	Red Green Blue	Red	Select the LUT channel to control. Note: Color model only
LUT Index	0 ~ 256	0	Set the LUT index table number.
LUT Value	0 ~ 4095	Value equivalent to Gamma = 1.0	Set the LUT index table number.

Color Transformation Control

Related Topic: [Color Space Conversion \(ColorTransformationControl\)](#)

Configure Color Transformation Control settings.

Note: Color model only

Color Transformation Control Item	Setting Range	Default	Description						
ColorTransformationMode	0: RGB (Default) 2: XYZ		Set the output image format.						
ColorTransformationRGBMode	0: Off (Default) 1: sRGB 2: AdobeRGB 3: UserCustom		Set the detailed mode when RGB is selected for the color space.						
ColorMatrixValueSelector	0: ColorMatrixR-R (Default) 1: ColorMatrixR-G 2: ColorMatrixR-B 3: ColorMatrixG-R 4: ColorMatrixG-G 5: ColorMatrixG-B 6: ColorMatrixB-R 7: ColorMatrixB-G 8: ColorMatrixB-B		Select the ColorMatrix setting component.						
ColorMatrixValue	-2.0 ~ 2.0	-	Set the Color Matrix value. <table border="1" data-bbox="766 1325 1516 1457"> <thead> <tr> <th>ColorMatrixValueSelector</th> <th>Default Value</th> </tr> </thead> <tbody> <tr> <td>R-R, G-G, B-B</td> <td>1.0</td> </tr> <tr> <td>Other than above</td> <td>0</td> </tr> </tbody> </table>	ColorMatrixValueSelector	Default Value	R-R, G-G, B-B	1.0	Other than above	0
ColorMatrixValueSelector	Default Value								
R-R, G-G, B-B	1.0								
Other than above	0								

Shading

Related Topic: [Shading Correction](#)

Configure settings for other JAI functions.

Shading Control Item	Setting Range	Default	Description
ShadingCorrectionMode	0: Flat Shading (Default) 1: Flat Shading User Area BE 2: Color Shading* 3: Color Shading User Area BE* Note: *Color model only		Select the shading correction method.
ShadingMode	0: Off (Default) 2: User1 3: User2 4: User3		Set the area to which to save shading correction data. When this is set to Off , shading correction is disabled.
CalibrateShadingCorrection	-	-	Execute shading correction.
ShadingCalibrationResult	0: Idle (Default) 3: Succeeded 4: Succeeded with BE condition 5: Error1 - Image was too bright 6: Error2 - Image was too dark 7: Error3 - Could not calibrated		Display the shading correction results. For more information, see " Shading Correction ".
ShadingDataSelector	0: Red (Default) 1: Green 2: Blue Note: Color model only		Selects which the color of shading data (color) to set.
ShadingDataIndex	1 ~ 1024	1	Selects which the index of shading data to set.
ShadingData	0 ~ 0x1FFFC*, Step 4	0x4000 (= x1)	Configure and display ShadingData selected by ShadingDataSelector and ShadingDataIndex. The set value is rounded down to multiples of 4. Note: *Upper limit when configured manually; values higher than this may be displayed when CalibrateShadingCorrection is performed.
ShadingDataSave	-	-	Overwrites the currently set ShadingData and saves it in one of the User1~User3 areas based on the ShadingMode value.

Correction

Correct variations due to sensors and lenses.

Note: Items with "*" are only supported on the color model.

Correction Control Item	Setting Range	Default	Description
PixelBlackCorrectionMode Related Topic: DSNU Correction (Pixel Black Correct)	0: Off 1: Default (Default) 2: User1 3: User2 4: User3		(DSNU) Select under which setting to store / load the correction values. Note: Default contains the correction data that was set at the factory.
CalibratePixelBlackCorrection	-	-	(DSNU) Generate black level correction data automatically from the captured image. Please follow the instructions on " DSNU Correction (Pixel Black Correct) ". Caution: When PixelBlackCorrectionMode is set to Off or Default, or test pattern is being output instead of an image, this command cannot be executed. In this case, " Error3 - Could not calibrated " is displayed on PixelBlackCalibrationResult .
PixelBlackCalibrationResult	-	-	(DSNU) Display the results of Calibrate Pixel Black Correction execution. 0: Idle (Default) 3: Succeeded 5: Error1 - Image was too bright 6: Error2 - Image was too dark 7: Error3 - Could not calibrated
PixelGainCorrectionMode Related Topic: PRNU Correction (Pixel Gain Correct)	0: Off 1: Default (Default) 2: User1 3: User2 4: User3 5: SelectedROI		(PRNU) Select under which setting to store / load the correction values. For detailed steps, see " PRNU Correction (Pixel Gain Correct) ". User1 ~ 3: Performs PRNU on the entire area (full ROI), and stores correction values in the selected area. SelectedROI: Performs PRNU on the area specified by the ROI settings (Width and OffsetX values [ImageFormatControl]), and stores correction values in UserArea. Note: Default contains the correction data that was set at the factory.

Correction Control Item	Setting Range	Default	Description
CalibratePixelGainCorrection	-	-	(PRNU) Generate gain correction data automatically from the captured image. Caution: When PixelGainCorrectionMode is set to Off or Default , or a test pattern is being output instead of an image, this command cannot be executed. In this case, " Error3 - Could not calibrated " is displayed on PixelGainCalibrationResult .
PixelGainCalibrationResult	-	-	(PRNU) Display the results of Calibrate Pixel Gain Correction execution. For more information on the results, see " PRNU Correction (Pixel Gain Correct) ". 0: Idle (Default) 3: Succeeded 4: Succeeded with BE condition 7: Error3 - Could not calibrated
ChromaticAberrationCorrectionMode*	0: Off (Default) 1: Lens1 2: Lens2 3: Lens3		Selects the area to load or save the Chromatic Aberration Correction values. Related Topic: Chromatic Aberration Correction
ChromaticAberrationCorrectionMethod*	0: Simple Interpolation (Default) 1: Linear Spline Interpolation 2: Custom		Selects the Chromatic Aberration Correction method. Simple Interpolation: Perform a two-point linear interpolation. Linear Spline Interpolation: Performs piecewise linear interpolation using a quadratic curve formula. Custom: Modify each correction point as desired.
ChromaticAberrationCorrectionSelector*	0: R channel (Default) 2: B channel		Selects the color of the Chromatic Aberration Correction values.
ChromaticAberrationCorrectionIndex*	0 ~ 8	1	Selects the Index to refer the Chromatic Aberration Correction Ratio values.
ChromaticAberrationCorrectionRatio*	-1.000 ~ 1.000; step 0.001	0.125	Sets the Chromatic Aberration Correction Ratio values.
ChromaticAberrationCorrection*	SW-2005TL -2.0 ~ 2.0; step 0.1 SW-4005BL -4.0 ~ 4.0; step 0.1	0	Sets the value of the Chromatic Aberration Correction.
ChromaticAberrationCorrectionCoeff*	1 ~ 10; step 0.1	2	Sets the coefficient value of the Chromatic Aberration Correction for Linear Spline Interpolation.

Correction Control Item	Setting Range	Default	Description
ChromaticAberrationCorrectionSave*	-	-	Save the related value of the Chromatic Aberration Correction features.
TiltViewCorrectionMode* Related Topic: Tilt View Correction	0: Off (Default) 1: User1 2: User2 3: User3		Selects the area to load or save the Tilt View Correction values. Note: Default contains the correction data that was set at the factory.
TiltViewCorrectionSelector*	0: R channel (Default) 2: B channel		Selects the color of the Tilt View Correction.
TiltViewCorrection*	- 1.0 ~ 1.0; step 0.1	0	Sets the value of the Tilt View Correction.
TiltViewCorrectionSave*	-	-	Save the value of the TiltViewCorrection.
FIRFilterSelector* Related Topic: Noise Reduction Filter Functions	0:Red (Default) 1:Green 2:Blue		Select the target to apply FIR Filter from Red, Green, Blue.
FIRFilterMode	0: Off 1: On	0: Off	Enable / Disable FIR Filter.
FIRFilterLeftRatio	-2 ~ 2	0	Set the coefficient of the left pixel when FIR Filter is applied.
FIRFilterCenterRatio	-2 ~ 2	1	Set the coefficient of the center pixel when FIR Filter is applied.
FIRFilterRightRatio	-2 ~ 2	0	Set the coefficient of the right pixel when FIR Filter is applied.
MEDIANFilterSelector*	0: Red (Default) 1: Green 2: Blue		Select the target to apply Median Filter from Red, Green, Blue.
MEDIANFilterMode	0: Off 1: On	0: Off	Enable / Disable MEDIAN Filter.
NoiseReduction	0: Off (Default) 1: Level1 2: Level2 3: Level3 4: Level4		Set the noise reduction intensity in 4 levels. Level1 = weak, Level4 = strong
CrossTalkCompensationMode Note: SW-4005BL Only Related Topic: Crosstalk Compensation Mode	1: Off 3: Default (Default) 4: User		Enable / disable crosstalk compensation on the SW-4005BL model. Off: Disable crosstalk compensation. Default: The compensation data set at the factory is saved. You cannot overwrite this data. User: You can save and load the user-configured compensation data.

Correction Control Item	Setting Range	Default	Description
CrossTalkCompensationValueGr	0 ~ 20 (step: 0.1)	0	When CrossTalkCompensationMode is set to User , set the crosstalk compensation value for Gr in percentage (%).
CrossTalkCompensationValueGb	0 ~ 20 (step: 0.1)	0	When CrossTalkCompensationMode is set to User , set the crosstalk compensation value for Gb in percentage (%).

SpatialControl

Corrects the spatial pixel differences for each line.

Related Topic: [Spatial Compensation](#)

Note: Items with "*" are also supported on the monochrome model.

Spatial Control Item	Setting Range	Default	Description
SpatialCompensationMode	0: Manual 1: Auto (Default)		Set the spatial compensation mode. Note: On SW-4005BL, this item is fixed to Manual.
SpatialCompensationSelector	SW-2005TL 0: Red (Default) 2: Blue SW-4005BL 0: RedAndBlue		Set the channel. Note: SpatialCompensationMode = Manual Only
SpatialCompensationValue (pixels)	-1.0 ~ 1.0; step: 0.01	0	Set the compensation value for each channel. Note: SpatialCompensationMode = Manual Only
ObjectDirection*	0: Forward Direction (Default) 1: Reverse Direction		Set the direction of moving objects.
ObjectDirectionSource*	11-14: UserOutput0-3 (Default = UserOutput0) 23: Line4 TTL In1 24: Line5 Opt In1 33: Line14 TTL In4 39: EncoderDirection		Select the input to use for obtaining the movement direction information for the object.

Spatial Control Item	Setting Range	Default	Description
SpatialCompensationDistance (pixels)	-1.0 ~ 1.0; step: 0.01	0	Set the amount of movement in pixels of the imaging subject within the sensor during a single trigger. Note: SpatialCompensationMode = Auto Only

Counter and Timer Control

Related Topic: [Counter and Timer Control](#)

Configure counter settings. (This camera only supports counter functions.)

Counter and Timer Control Item	Setting Range	Default	Description
CounterSelector	0: Counter0 (Default) 1: Counter1 2: Counter2 3: Counter3 4: Counter4 5: Counter5		Select the counter.
CounterEventSource	0: Off (Default) 1: Line Trigger (Counter0 Only) 2: Line Start (Counter1 Only) 3: Exposure Start (Counter2 Only) 4: Frame Trigger (Counter3 Only) 5: Frame Start (Counter4 Only) 6: FrameTransferEnd (Counter5 Only)		Select the counter event signal for which to read the count value.
CounterEventActivation	1: RisingEdge 2: FallingEdge		Display the timing at which to count. Counter 0 ~ 4: RisingEdge (Fixed) Counter 5: FallingEdge (Fixed)
CounterResetSource	0: Software (Default) 23: Line4 TTL In1 24: Line5 Opt In1 33: Line14 TTL In4		Select the signals that will be the source to reset the Counter. When set to Software, the counter value is reset by the CounterReset command. If set to a value other than Software, the counter is reset by the line input signal (GPIO).
CounterResetActivation	1: RisingEdge (Default) 2: FallingEdge 3: LevelHigh 4: LevelLow		Set the counter reset timing when CounterResetSource is set to a value other than Software.

Counter and Timer Control Item	Setting Range	Default	Description
CounterReset	-	-	Reset the counter.
Counter Value	0 ~ 32bit max	0	Display the count value.
CounterStatus	0: CounterIdle (Default) (CounterEventSource = Off) 1: CounterTriggerWait 2: CounterActive (CounterEventSource = other than Off) 3: CounterCompleted 4: CounterOverflow (CounterEventSource = other than Off and CounterValue = Max)		Display the counter status.

EncoderControl

Related Topic: [Connecting Rotary Encoders](#)

Configure settings for encoder control.

Encoder Control Item	Setting Range	Default	Description
EncoderSourceA EncoderSourceB	0: Off (Default) 23: Line4 TTL In1 24: Line5 Opt In1 33: Line14 TTL In4		Select where to input the signal from the rotary encoder.
EncoderTriggerOption	0: EncoderDivider (Default) 1: EdgeDetection		Select the encoder triggering method. EncoderDivider specifies the number of triggers to generate as a ratio (65536 / EncoderDivider value). EncoderDetection specifies the number of edges to pass between encoder trigger signals.
EncoderDivider Related Topic: EncoderDivider Trigger Option	1~ 32bit max	65536	When EncoderDivider is selected for EncoderTriggerOption , set the number of triggers to be generated as a ratio 65536 / (set value).
EncoderEdgeDetectionPassCount Related Topic: EdgeDetection Trigger Option	0 ~ 65535	0	When EdgeDetection is selected for EncoderTriggerOption , set how many edges to pass between encoder trigger signals.

Encoder Control Item	Setting Range	Default	Description
EncoderOutputMode Related Topic: Resume Scanning (Backward Counter)	1: PositionUp 2: PositionDown 5: Motion (Default)		Specify the condition under which a valid encoder output signal is generated. PositionUp: Outputs images at all new positions in the positive direction (when ObjectDirection [SpatialControl] is set to Forward Direction). When the direction of encoder rotation is reversed, the camera stops outputting images until EncoderOutputMaskedCount returns 0, while output pulses continue to be generated. PositionDown: Outputs images at all new positions in the negative direction (when ObjectDirection [SpatialControl] is set to Forward Direction). When the direction of encoder rotation is reversed, the camera stops outputting images until EncoderOutputMaskedCount returns 0, while output pulses continue to be generated. Motion: Outputs images at all motion increments in both directions.
EncoderOutputMaskedCount	0 ~ 32bit max	0	Display the number of pulses during the reverse rotation after the AcquisitionStart command when EncoderOutputMode is set to PositionUp or PositionDown . The counter counts up during the reverse rotation. The counter counts down when rotation returns to the direction set by EncoderOutputMode .
EncoderFilter (ns)	0 ~ 150, step: 10	0	Apply a low-pass filter to prevent noise on the signal from the rotary encoder and stabilize the signal for the specified number of cycles.
EncoderStrobe (ns)	10 ~ 2550, step: 10	100	Set the strobe length of the Trigger signal generated from the rotary encoder by the number of cycles.
EncoderAveragingInterval	0: none (Default) 1: 2 pulses 2: 4 pulses 3: 8 pulses 4: 16 pulses 5: 32 pulses		When EncoderOutputMode is set to EncoderDivider and EncoderDivider is not set to an integer multiple of 65536, use this setting if the reliability of the interval of the signal output from the rotary encoder is low (some signal interval is extremely long or short; the encoder's jitter is large). When this function is enabled, internal processing is performed by averaging the interval of several previous signals.
EncoderMaxIntervalForNonDecimationMode (s)	0 ~ 60	0	When EncoderOutputMode is set to EncoderDivider and EncoderDivider is not set to an integer multiple of 65536, set the maximum interval period of the output signal. This setting item is disabled when EncoderDivider is set to an integer multiple of 65536. 0: The trigger output period is calculated using the encoder input period only. 1 ~ 60: The trigger output period is calculated using the encoder input period and this setting.

Logic Block Control

Related Topic: [Logic Block Control](#)

Configure Logic Block settings.

Logic Block Control Item	Setting Range	Default	Description
Logic Block Selector	0: Logic Block 0 (Default) 1: Logic Block 1 2: Logic Block 2 3: Logic Block 3		Specifies the Logic Block to configure.
Logic Block Function	AND (Fixed)		Selects the combinational logic Function of the Logic Block to configure.
Logic Block Input Selector	0 ~ 1	0	Selects the Logic Block's input to configure.
Logic Block Input Source	4: ExposureActive 6: LVAL 7: PulseGenerator0 8: PulseGenerator1 9: PulseGenerator2 10: PulseGenerator3 11: UserOutput0 12: UserOutput1 13: UserOutput2 14: UserOutput3 23: Line4 TTL In1 (Default) 24: Line5 Opt In1 33: Line14 TTL In4 36: Logic Block0 37: Logic Block1 38: Logic Block2 39: Logic Block3 40: Encoder Trigger 41: Encoder Direction		Selects the source signal for the input into the Logic Block.
Logic Block Input Inverter	0: False 1: True	0: False	Selects if the selected Logic Block Input source signal is inverted.
Logic Block Output Inverter	True (Fixed)		Selects if the selected Logic Block Output signal is inverted.

ActionControl

Related Topic: [Action Control Function](#)

Configure action control settings.

Action Control Item	Setting Range	Default	Description
Action Device Key	0x0 ~ 0xFFFFFFFF	0x00	Set the action device key.
Action Queue Size	0 ~ 32bit max	256	Set the size of action queue.
Action Selector	0 ~ 3	0	Select the action.
Action Group Mask	0x0 ~ 0xFFFFFFFF	0x00	Set the mask value that creates the action 0 group,
Action Group Key	0x0 ~ 0xFFFFFFFF	0x00	Set the key that executes action 1.

ChunkDataControl

Related Topic: [Chunk Data Function](#)

Configure Chunk Control settings.

Note: Items with "*" are only supported on the color model.

Chunk Data Control Items	Setting Range	Default	Description
ChunkModeActive	0: False 1: True	0: False	Set whether to enable ChunkData.
ChunkSelector	Selects which Chunk to enable or control. Options are listed below. 1: OffsetX (Default), 2: OffsetY, 3: Width, 4: Height, 5: BinningHorizontal, 7: PixelFormat, 8: Timestamp, 9: LineStatusAllOnExposureStart, 10: LineStatusAllOnLVALStart, 11: LineStatusAllOnLVALEnd, 12: CounterValue, 13: ExposureTime, 14: Gain, 15: BlackLevel, 16: DeviceSerialNumber, 17: DeviceUserID, 18: DeviceTemperature, ChunkTimeStamp		
ChunkEnable	0: False 1: True	0: False	Enables the inclusion of the selected Chunk data in the payload of the image.

Chunk Data Control Items	Setting Range	Default	Description	
ChunkImage	-	-	Returns the entire image data included in the payload.	
ChunkOffsetX	-	-	Display the OffsetX value (ImageFormatControl). ChunkID: 0x2000	
ChunkOffsetY	-	-	Display the OffsetY value (ImageFormatControl). ChunkID: 0x2001	
ChunkWidth	-	-	Display the Width value (ImageFormatControl). ChunkID: 0x2002	
ChunkHeight	-	-	Display the Height value (ImageFormatControl). ChunkID: 0x2003	
ChunkBinningHorizontal	-	-	Display the BinningHorizontal value (ImageFormatControl). ChunkID: 0x2022	
ChunkPixelFormat	-	-	Display the PixelFormat value (ImageFormatControl). ChunkID: 0x2012	
ChunkLineStatusAllOnExposureStart	-	-	Display the LineStatusAll (DigitalIOControl) value. The data acquisition timing is on the first line's exposure start, and the displayed value is the value determined by the Line Inverter setting. ChunkID: 0x2015	
ChunkLineStatusAllOnLVALStart	-	-	Display the LineStatusAll (DigitalIOControl) value. The data acquisition timing is on the first line's FVAL, and the displayed value is the value determined by the Line Inverter setting. ChunkID: 0x2027	
ChunkLineStatusAllOnLVALEnd	-	-	Display the LineStatusAll (DigitalIOControl) value. The data acquisition timing is on the first line's FVAL, and the displayed value is the value determined by the Line Inverter setting. ChunkID: 0x2028	
ChunkCounterSelector	-	-	Select the Counter to display.	
ChunkCounterValue	-	-	CounterValue (Counter and Timer Control).	
			ChunkID: 0x2029	ChunkLineTriggerCounter
			ChunkID: 0x202A	ChunkLineStartCounter
			ChunkID: 0x200F	ChunkExposureStartCounter
			ChunkID: 0x200E	ChunkFrameTriggertCounter
			ChunkID: 0x202B	ChunkFrameStartCounter
ChunkID: 0x2011	ChunkFrameTransferEndCounter			
*ChunkExposureTimeSelector	-	-	Select the ExposureTime to display.	
Note: SW-2005TL-5GE Only				

Chunk Data Control Items	Setting Range	Default	Description	
ChunkExposureTime	-	-	Display the ExposureTime (AcquisitionControl) value. The data acquisition timing is on the first line's ExposureTime.	
			ChunkID: 0x2004	ChunkExposureTimeCommon
			ChunkID: 0x2004	ChunkExposureTimeGreen
			ChunkID: 0x201C	ChunkExposureTimeRed
ChunkID: 0x201D	ChunkExposureTimeBlue			
*ChunkIndividualGainMode	-	-	Display the IndividualGainMode value (AnalogControl). ChunkID: 0x201E	
*ChunkGainSelector	-	-	Select the Gain to display.	
ChunkGain	-	-	Display the Gain value (AnalogControl).	
			ChunkID: 0x201F	ChunkGainAnalogAll
			ChunkID: 0x201F	ChunkGainAnalogGreen
			ChunkID: 0x2020	ChunkGainAnalogRed
ChunkID: 0x2021	ChunkGainAnalogBlue			
*ChunkBlackLevelSelector	-	-	Select the BlackLevel to display.	
ChunkBlackLevel	-	-	Display the BlackLevel value (AnalogControl).	
			ChunkID: 0x2008	ChunkBlackLevelDigitalAll
			ChunkID: 0x2008	ChunkBlackLevelDigitalGreen
			ChunkID: 0x2009	ChunkBlackLevelDigitalRed
ChunkID: 0x200A	ChunkBlackLevelDigitalBlue			
ChunkDeviceSerialNumber	-	-	Display the DeviceSerialNumber (DeviceControl) value. ChunkID: 0x2017	
ChunkDeviceUserID	-	-	Display the DeviceUserID (DeviceControl) value. ChunkID: 0x2018	
ChunkDeviceTemperatureSelector	-	-	Select the DeviceTemperature to display.	
ChunkDeviceTemperature	-	-	Display the DeviceTemperature (DeviceControl) value. ChunkID: 0x2019	
ChunkTimestamp	-	-	Display the Timestamp value (DeviceControl). ChunkID: 0x2014	

EventControl

Related Topic: [Event Control Function](#)

Configure event control settings.

Note: Items with "*" are only supported on the SW-4005TL model. Items with "***" are supported on the monochrome models and SW-4005BL model.

Caution: This camera has a limitation when enabling Event function(s) other than AcquisitionStart / AcquisitionStop Event. See "[Event Control Function](#)" for more information.

Event Control Item	Setting Range	Default	Description
EventSelector	0: AcquisitionStart (Default) 2: FrameStart 4: ExposureRedStart* 6: Exposure (Green) Start 8: ExposureBlueStart* 28: LVALStart	1: AcquisitionEnd 3: FrameEnd 5: ExposureRedEnd* 7: Exposure (Green) End 9: ExposureBlueEnd* 29: LVALEnd	
EventNotification	0: Off (Default) 1: On		Select whether to output the Event message selected by EventSelector . When set to On , the following data will be displayed each time the specified Event occurs.
EventAcquisitionStartData			Display the following data when the Event occurs.
EventAcquisitionStart	-	0x9011	Display the EventID.
EventAcquisitionStartTimestamp	0 ~ 64bit max	0	Display the Timestamp value when an Event occurred.
EventAcquisitionStartFrameID			Displays the FrameID value when an event occurs.
EventAcquisitionEndData			Display the following data when the Event occurs.
EventAcquisitionEnd	-	0x9012	Display the EventID.
EventAcquisitionEndTimestamp	0 ~ 64bit max	0	Display the Timestamp value when the Event occurred.
EventAcquisitionEndFrameID			Displays the FrameID value when an event occurs.
EventFrameStartData			Display the following data when the Event occurs.
EventFrameStart	-	0x9300	Display the EventID.
EventFrameStartTimestamp	0 ~ 64bit max	0	Display the Timestamp value when an Event occurred.

Event Control Item	Setting Range	Default	Description
EventFrameStartFrameID			Displays the FrameID value when an event occurs.
EventFrameEndData			Display the following data when the Event occurs.
EventFrameEnd	-	0x9301	Display the EventID.
EventFrameEnd Timestamp	0 ~ 64bit max	0	Display the Timestamp value when the Event occurred.
EvenFrameEndFrameID			Displays the FrameID value when an event occurs.
*EventExposureRedStartData			Display the following data when the Event occurs.
*EventExposureRedStart	-	0x9302	Display the EventID.
*EventExposureRedStart Timestamp	0 ~ 64bit max	0	Display the Timestamp value when the Event occurred.
*EventExposureRedStartFrameID			Displays the FrameID value when an event occurs.
*EventExposureRedEndData			Display the following data when the Event occurs.
Event ExposureRedEnd	-	0x09303	Display the EventID.
*EventExposureRedEnd Timestamp	0 ~ 64bit max	0	Display the Timestamp value when the Event occurred.
*EventExposureRedEndFrameID			Displays the FrameID value when an event occurs.
*EventExposureGreenStartData			Display the following data when the Event occurs.
*EventExposureGreenStart	-	0x9304	Display the EventID.
*EventExposureGreenStart Timestamp	0 ~ 64bit max	0	Display the Timestamp value when the Event occurred.
*EventExposureGreenStartFrameID			Displays the FrameID value when an event occurs.
*EventExposureGreenEndData			Display the following data when the Event occurs.
*EventExposureGreenEnd	-	0x9305	Display the EventID.
*EventExposureGreenEnd Timestamp	0 ~ 64bit max	0	Display the Timestamp value when the Event occurred.
*EventExposureGreenEndFrameID			Displays the FrameID value when an event occurs.
*EventExposureBlueStartData			Display the following data when the Event occurs.
*Event ExposureBlueStart	-	0x9306	Display the EventID.
*Event ExposureBlueStart Timestamp	0 ~ 64bit max	0	Display the Timestamp value when the Event occurred.
*EventExposureBlueStartFrameID			Displays the FrameID value when an event occurs.

Event Control Item	Setting Range	Default	Description
*EventExposureBlueEndData			Display the following data when the Event occurs.
*EventExposureBlueEnd	-	0x9307	Display the EventID.
*EventExposureBlue Timestamp	0 ~ 64bit max	0	Display the Timestamp value when the Event occurred.
*EventExposureBlueEndtFrameID			Displays the FrameID value when an event occurs.
**EventExposureStartData			Display the following data when the Event occurs.
**EventExposureStart	-	0x9304	Display the EventID.
**EventExposureStart Timestamp	0 ~ 64bit max	0	Display the Timestamp value when the Event occurred.
**EventExposureStartFrameID			Displays the FrameID value when an event occurs.
**EventExposureEndData			Display the following data when the Event occurs.
**EventExposureEnd	-	0x9305	Display the EventID.
**EventExposureEnd Timestamp	0 ~ 64bit max	0	Display the Timestamp value when the Event occurred.
**EventExposureEndFrameID			Displays the FrameID value when an event occurs.
EventLVALStartData			Display the following data when the Event occurs.
EventLVALStart	-	0x9330	Display the EventID.
EventLVALStartTimestamp	0 ~ 64bit max	0	Display the Timestamp value when the Event occurred.
EventLVALStartFrameID			Displays the FrameID value when an event occurs.
EventLVALEndData			Display the following data when the Event occurs.
EventLVALEnd	-	0x9331	Display the EventID.
EventLVALTimestamp	0 ~ 64bit max	0	Display the Timestamp value when the Event occurred.
EventLVALEndFrameID			Displays the FrameID value when an event occurs.

UserSetControl

Related Topic: [Step 7: Save the Settings](#)

Load factory default settings or save/load user settings for camera settings.

User Set Control Item	Setting Range	Default	Description
User Set Selector	Default User Set1 ~ 3	0: Default (factory default values)	Select the user settings.
User Set Load	-	-	Load user settings.
User Set Save	-	-	Save the current setting values as user settings.

Miscellaneous

Troubleshooting

Check the following before requesting help. If the problem persists, contact your local JAI distributor.

■ Power Supply and Connections

Issue: The POWER/TRIG LED remains lit amber and does not turn green, even after power is supplied to the camera.

Cause and Solution: Camera initialization may not be complete. Check the 12-pin cable connection.

■ Image Display

Issue: Gradation in dark areas is not noticeable.

Cause and Solution: Use the gamma function to correct the display. As the light-emitting properties of the monitor are not linear, the entire image may be darker or the gradation in the dark areas may be less noticeable when camera outputs are displayed without processing. Using the gamma function performs correction to produce a display that is close to linear. For details, see [Gamma Function](#).

■ Settings and Operations

Issue: Settings cannot be saved to user memory.

Cause and Solution: You cannot save to user memory while images are being captured by the camera. Stop image capture before performing the save operation.

Issue: I want to restore the factory default settings.

Cause and Solution: Load **Default** under User Set Selector in the Feature Properties tab to restore the factory default settings.

Specifications

Item	Specifications			
Image Sensor	SW-2005TL-5GE: Trilinear (Color) CMOS line scan image sensor			
	SW-2005M-5GE: Monochrome CMOS line scan image sensor			
	SW-4005BL-5GE: Bilinear (Color) CMOS line scan image sensor			
	SW-4005M-5GE: Monochrome CMOS line scan image sensor			
			Effective Pixels	Pixel Size
SW-2005TL-5GE		2048 x 3 (R, G, B)	7.0µm x 7.0µm	
SW-2005M-5GE		2048 x 1	7.0µm x 7.0µm	
SW-4005BL-5GE		4096 x 2 (RB-G)	3.5µm x 3.5µm	
SW-4005M-5GE		4096 x 1	3.5µm x 3.5µm	
Synchronization	Internal			
Communication Interface	5GBASE-T Ethernet (GigE Vision 2.0), IEEE 802.3af			
Line Rate (Color model)	PixelFormat	Min	SW-2005TL-5GE	SW-4005BL-5GE
	RGB8	66 Hz	44kHz	42kHz
	RGB10V1Packed	66 Hz	44kHz	34kHz
	RGB10p32			
	RGB12V1Packed	66 Hz	44kHz	30kHz
	BiColorRGBG8	66 Hz	NA	42kHz
	BiColorRGBG10	66 Hz	NA	34kHz
	BiColorRGBG12			
	BiColorRGBG10p	66 Hz	NA	42kHz
	BiColorRGBG12p			
Note: *When taking a trigger signal from the outside, there is no limitation on the minimum value				
Line Rate (Monochrome model)	PixelFormat	Min	SW-2005M-5GE	SW-4005M-5GE
	Mono8	66 Hz	172kHz	84kHz
	Mono10	66 Hz	129kHz	66kHz
	Mono12			
	Mono10Packed	66 Hz	167kHz	84kHz
Mono12Packed				
Note: *When taking a trigger signal from the outside, there is no limitation on the minimum value				

Item	Specifications		
Dark SN (Color model)	Channel	SW-2005TL-5GE	SW-4005BL-5GE
	R	51.5 dB (Typ)	49.5 dB (Typ)
	G	52.5 dB (Typ)	52.5 dB (Typ)
	B	51.0 dB (Typ)	51.0 dB (Typ)
	Dark Level@10bit (Individual Gain = Off); DSNU Correction = On; GainDigitalAll/GainDigitalRed /GainDigitalBlue = 0dB		
Dark SN (Monochrome model)	Channel	SW-2005M-5GE	SW-4005M-5GE
	Mono	58.0 dB (Typ)	58.0 dB (Typ)
	Dark Level@10bit; DSNUCorrection = On; DigitalGainAll: 0dB		
Bright SN (Color model)	Channel	SW-2005TL-5GE	SW-4005BL-5GE
	R	32.0 dB (Typ)	31.0 dB (Typ)
	G	32.0 dB (Typ)	32.0 dB (Typ)
	B	31.5 dB (Typ)	31.5 dB (Typ)
	890LSB@10bit (Individual Gain = Off); DSNU and PRNU Correction = On; GainDigitalAll/GainDigitalRed /GainDigitalBlue = 0dB		
Bright SN (Monochrome model)	Channel	SW-2005M-5GE	SW-4005M-5GE
	Mono	35.5 dB (Typ)	35.5 dB (Typ)
	890LSB@10bit; DSNU and PRNU Correction = On; GainDigitalAll = 0dB		
Digital Image Output Format		SW-2005 Models	SW-4005 Models
	Width	128(64) ~ 2048(1024) pixels, 8 (8) pixels/step	128(64) ~ 4096(2048), 8 (8) pixels/step
	OffsetX	0 ~ 1920 (960) pixels, 8 (8) pixels/step	0 ~ 3968 (1984) pixels, 8 (8) pixels/step
	Height	1 ~ 4096	1 ~ 4096
	Pixel Format (Color)	SW-2005TL-5GE : RGB8 (Default), RGB10V1Packed, RGB10p32, RGB12V1Packed	SW-4005BL-5GE : RGB8 (Default), RGB10V1Packed, RGB10p32, RGB12V1Packed, BiColorRGBG8, BiColorRGBG10, BiColorRGBG10p, BiColorRGBG12, BiColorRGBG12p
	Pixel Format (Mono)	SW-2005M-5GE : Mono8 (Default), Mono10, Mono12, Mono10Packed, Mono12Packed	SW-4005M-5GE : Mono8 (Default), Mono10, Mono12, Mono10Packed, Mono12Packed
(): BinningHorizontal = 2 (Width/OffsetX)			
Acquisition Mode	SingleFrame, MultiFrame (AcquisitionFrameCount: 1 ~ 65535), Continuous		

Item	Specifications		
Exposure Mode	Model	ExposureMode	ExposureTime (step 0.01µs , Including Exposure Offset Time)
	SW-2005TL-5GE	Off	Line Period - 0.4µs
		Timed (Trigger Off)	3.22 µs ~ 15.148 ms
		Timed (Trigger On)	3.22 µs ~ 15.148 ms
		TriggerWidth*	Trigger Width + 3.11 µs (3.22 µs~1s)
	SW-2005M-5GE	Off	Line Period - 0.4 µs
		Timed (Trigger Off)	1.65 µs ~ 15.148 ms
		Timed (Trigger On)	1.65 µs ~ 15.148 ms
		TriggerWidth*	Trigger Width +1.54 µs (1.65 µs~1s)
	SW-4005BL-5GE	Off	Line Period - 0.4µs
		Timed (Trigger Off)	3.22 µs ~ 15.148 ms
		Timed (Trigger On)	3.22 µs ~ 15.148 ms
		TriggerWidth*	Trigger Width +3.11 µs (3.22 µs~1s)
	SW-4005M-5GE	Off	Line Period - 0.4µs
Timed (Trigger Off)		2.17 µs ~ 15.148 ms	
Timed (Trigger On)		2.17 µs ~ 15.148 ms	
TriggerWidth*		Trigger Width +2.06 µs (2.17 µs~1s)	
<p>*LineStart trigger Only When TriggerMode is set to On, there is a delay time between the external trigger input and the start of the exposure. For more information, see "Delay Time from Trigger Input to Start of Exposure".</p>			
<p>ExposureTimeMode: Common, Individual (Individual = Color model only)</p>			
Trigger Selector	Acquisition: AcquisitionStart / AcquisitionEnd Exposure: LineStart, FrameStart Transfer: FrameTransferStart		
Trigger Input Signals	<p>12-pin: TTL In x2, Opto In, Software, Pulse Generator x4, Logic Block x 4, Encoder Trigger Positive / negative logic switchable. Minimum trigger width: 0.11µs and more</p>		
Gain Adjustment	Model	Mode	Manual Adjustment
	Color model	Master Mode	DigitalAll: 0 ~ 30dB DigitalRed/DigitalBlue: -7.96 ~ +12dB
		Individual Gain Mode	DigitalGreen, DigitalRed, DigitalBlue: 0 ~ 36dB
	Monochrome model	-	DigitalAll: 0 ~ 36dB
<p>GainAuto: Off, Once, Continuous (Continuous = Master Mode Only)</p>			
Black Level Adjustment	Model		
	Color model	DigitalAll, DigitalRed, DigitalBlue: -133 ~ +255 (LSB@12bit)	
	Monochrome model	DigitalAll: -133 ~ +255 (LSB@12bit)	

Item	Specifications																				
White Balance	BalanceWhiteAuto: Off, Once, Once User Area BE, Preset5000K, Preset6500K, Preset7500K (Color model only)																				
Test Pattern	White, GreyPattern1(Ramp), GreyPattern2 (Stripe), ColorBar* (*Color model only)																				
Image Processing	<p>Pixel Sensitivity Correction: Pixel Correction (DSNU, PRNU)</p> <p>Shading Correction: FlatShading, FlatShadingUserAreaBE, ColorShading, ColorShadingUserAreaBE</p> <p>LUT: Off : y =1.0, ON: 257 points can be set.</p> <p>Gamma: 0.45, 0.5, 0.55, 0.6, 0.65, 0.75, 0.8, 0.9, 1.0 (9 steps available)</p> <p>Noise Reduction Filter (MEDIAN, FIR, NoiseReduction)</p>																				
Power Supply (12-pin)	<table border="1"> <thead> <tr> <th></th> <th>SW-2005TL-5GE</th> <th>SW-2005M-5GE</th> <th>SW-4005BL-5GE</th> <th>SW-4005M-5GE</th> </tr> </thead> <tbody> <tr> <td>Input Range</td> <td colspan="4">DC + 10.8V ~ + 26.4V</td> </tr> <tr> <td>Consumption*</td> <td>6.3W (Typ.), 7.7W (Max)</td> <td>6.0W (Typ.), 7.7W (Max)</td> <td>6.4W (Typ.), 8.0W (Max)</td> <td>6.3W (Typ.), 8.2W (Max)</td> </tr> <tr> <td colspan="5">*Default 25°C Environment @DC +12V</td> </tr> </tbody> </table>		SW-2005TL-5GE	SW-2005M-5GE	SW-4005BL-5GE	SW-4005M-5GE	Input Range	DC + 10.8V ~ + 26.4V				Consumption*	6.3W (Typ.), 7.7W (Max)	6.0W (Typ.), 7.7W (Max)	6.4W (Typ.), 8.0W (Max)	6.3W (Typ.), 8.2W (Max)	*Default 25°C Environment @DC +12V				
		SW-2005TL-5GE	SW-2005M-5GE	SW-4005BL-5GE	SW-4005M-5GE																
	Input Range	DC + 10.8V ~ + 26.4V																			
	Consumption*	6.3W (Typ.), 7.7W (Max)	6.0W (Typ.), 7.7W (Max)	6.4W (Typ.), 8.0W (Max)	6.3W (Typ.), 8.2W (Max)																
*Default 25°C Environment @DC +12V																					
Power Supply (PoE)	<table border="1"> <thead> <tr> <th></th> <th>SW-2005TL-5GE</th> <th>SW-2005M-5GE</th> <th>SW-4005BL-5GE</th> <th>SW-4005M-5GE</th> </tr> </thead> <tbody> <tr> <td>Input Range</td> <td colspan="4">DC +37V ~ 57V</td> </tr> <tr> <td>Consumption*</td> <td>7.1W (Typ.), 8.7W (Max)</td> <td>6.8W (Typ.), 8.7W (Max)</td> <td>7.2W (Typ.), 8.9W (Max)</td> <td>7.1W (Typ.), 9.2W (Max)</td> </tr> <tr> <td colspan="5">*Default 25°C Environment</td> </tr> </tbody> </table> <p>Caution: Use a UTP Ethernet cable when power is supplied via the PoE function.</p>		SW-2005TL-5GE	SW-2005M-5GE	SW-4005BL-5GE	SW-4005M-5GE	Input Range	DC +37V ~ 57V				Consumption*	7.1W (Typ.), 8.7W (Max)	6.8W (Typ.), 8.7W (Max)	7.2W (Typ.), 8.9W (Max)	7.1W (Typ.), 9.2W (Max)	*Default 25°C Environment				
		SW-2005TL-5GE	SW-2005M-5GE	SW-4005BL-5GE	SW-4005M-5GE																
	Input Range	DC +37V ~ 57V																			
	Consumption*	7.1W (Typ.), 8.7W (Max)	6.8W (Typ.), 8.7W (Max)	7.2W (Typ.), 8.9W (Max)	7.1W (Typ.), 9.2W (Max)																
*Default 25°C Environment																					
Lens Mount	C (Thread pitch: 0.79375mm)																				
Back flange distance	17.526 mm, tolerance: 0 mm to ~ 0.05 mm																				
IR Cut Filter	Color model only																				
Verified Performance Temperature/Humidity	<p>0°C ~ +45°C (20 to 80%, non-condensing)</p> <p>Note: It may change depending on the installation environment. Please refer to the Caution in this section.</p>																				
Storage Temperature/Humidity	-25°C ~ +60°C (20 to 80%, non-condensing)																				
Vibration Resistance	10G (20 Hz~ 200 Hz X-Y-Z direction)																				
Shock Resistance	80G																				
Regulations	CE (EN55032:2015/A11:2020, EN55035:2017(CISPR35:2016)), FCC Part 15 Subpart B, RoHS/WEEE, KC																				
Dimensions	44mm × 44mm × 64mm (WHD; excluding lens mount protrusions and connectors)																				

Item	Specifications			
Weight	SW-2005TL-5GE	SW-4005BL-5GE	SW-2005M-5GE	SW-4005M-5GE
	186 g	186 g	185 g	185 g

Notes:

- Design and specifications are subject to change without notice.
- Approximately 30 minutes of warm-up are required to achieve these specifications.

Caution: About the verified performance temperature

Make sure the following temperature conditions are met when operating the unit.

- The camera's internal temperature should not exceed 60 °C during operation.

If the above temperature conditions are exceeded, take measures to dissipate heat according to your installation environment and conditions. For an example of the heat dissipation method, see the "[Appendix](#)" page.

Spectral Response (Color model)

SW-2005TL-5GE

SW-2005 Sensitivity

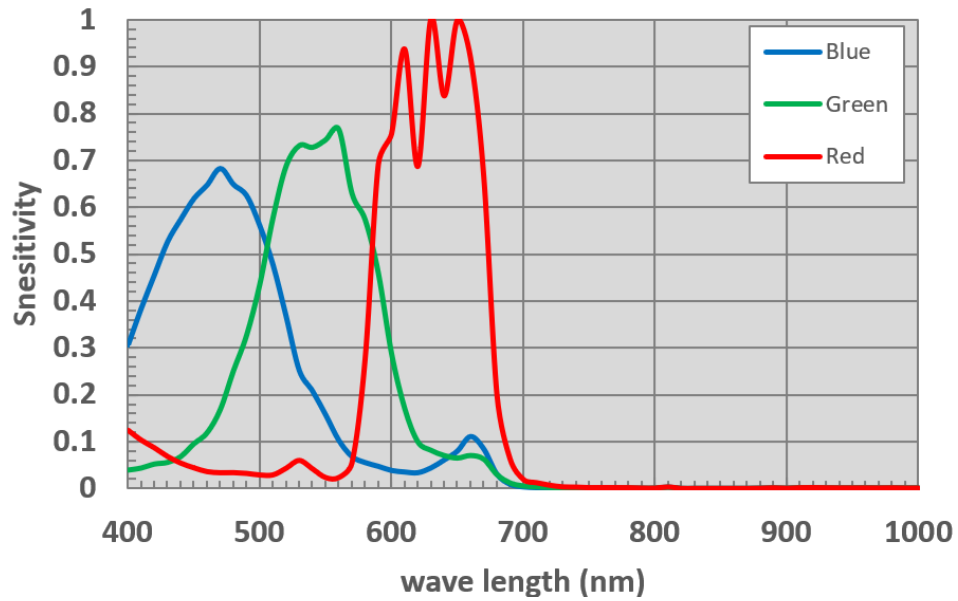

SW-4005BL-5GE

SW-4005 Sensitivity

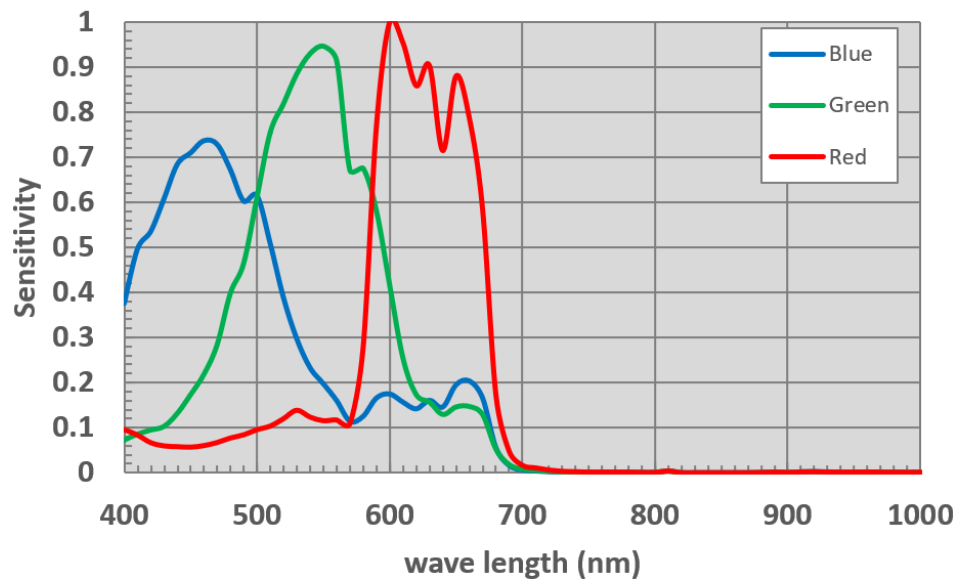

Spectral Response (Monochrome model)

SW-2005TL-5GE

SW-2005 Sensitivity

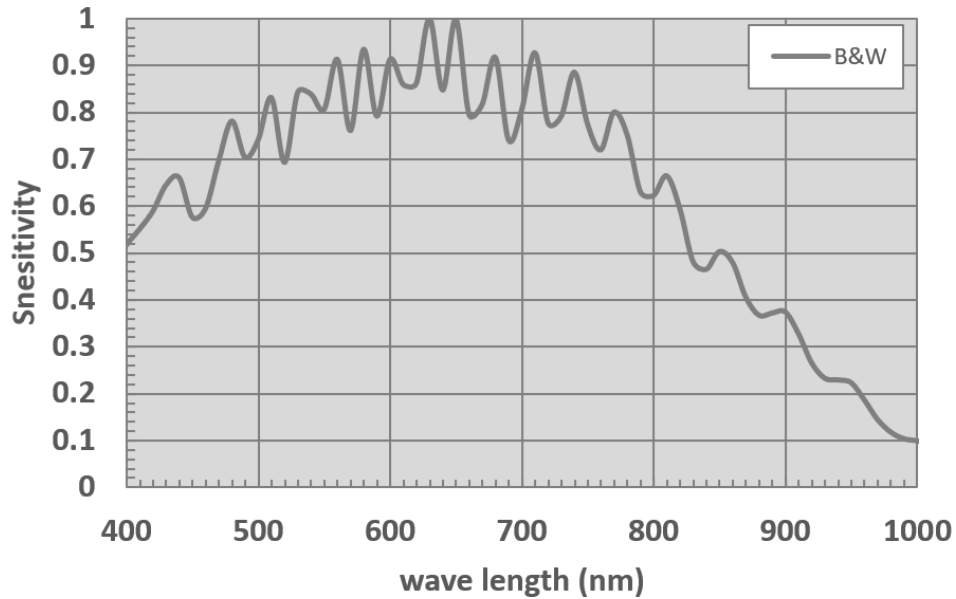

SW-4005M-5GE

SW-4005 Sensitivity

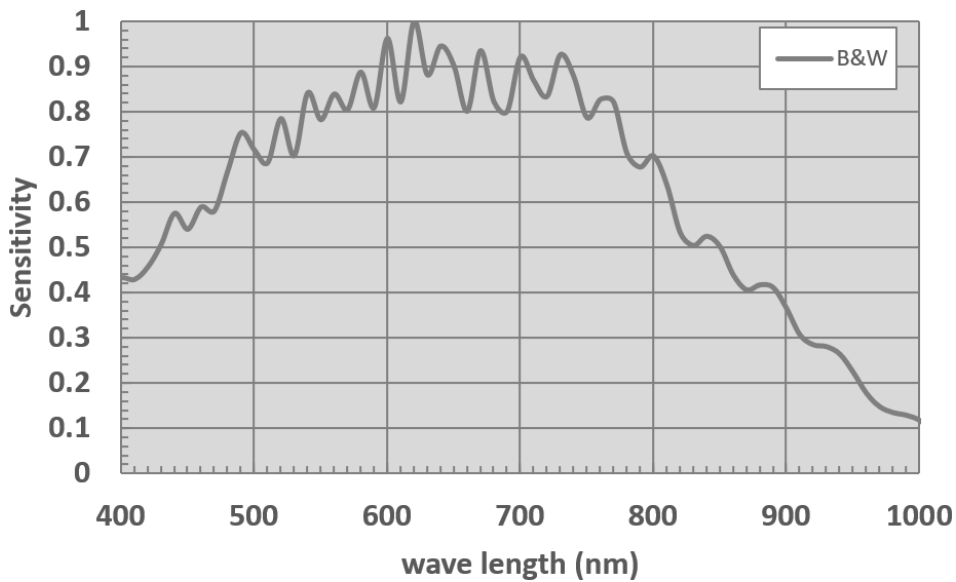

Dimensions

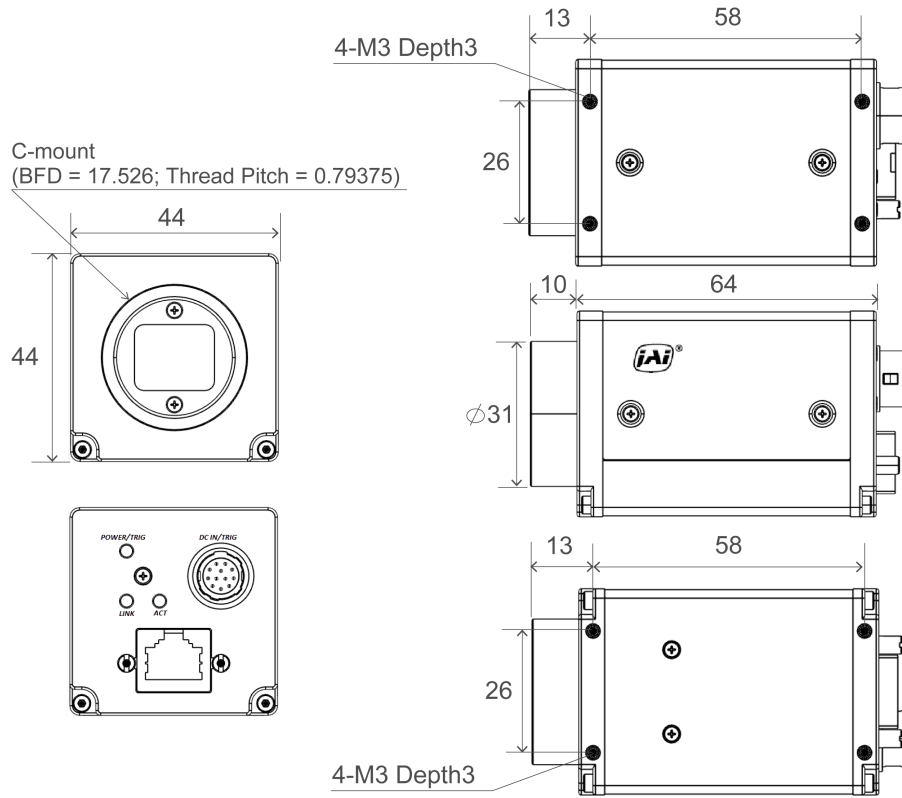

Notes:

- Dimensional tolerance: $\pm 0.3\text{mm}$
- Unit: mm

Comparison of the Decibel Display and Multiplier Display

Decibels (dB)	Multipliers (x)	Remarks
-6	0.501	
-5	0.562	
-4	0.631	
-3	0.708	
-2	0.794	
-1	0.891	
0	1	
1	1.122	
2	1.259	
3	1.413	
4	1.585	
5	1.778	
6	1.995	
7	2.239	
8	2.512	
9	2.818	
10	3.162	
11	3.548	
12	3.981	
13	4.467	
14	5.012	
15	5.623	
16	6.31	
17	7.0790	
18	7.943	
19	8.913	
20	10	
21	11.22	
22	12.589	
23	14.125	
24	15.849	
25	17.783	
26	19.953	
27	22.387	
28	25.119	
29	28.184	
30	31.623	
31	35.481	

Decibels (dB)	Multipliers (×)	Remarks
32	39.811	
33	44.668	
34	50.119	
35	56.235	
36	63.096	

User's Record

Model name:

Revision:

Serial No:

Firmware version:

For camera revision history, please contact your local JAI distributor.

Appendix

This section provides information about the thermal management of this camera.

Recommended Passive Cooling Method

If the camera's internal temperature exceeds the allowed maximum temperature (60°C), JAI recommends attaching a thermal pad to the camera and place a metal plate over it.

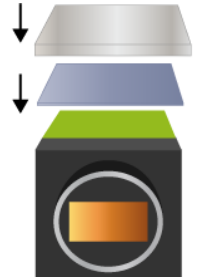

Notes:

- A thermal pad and metal plate can be attached to the top, bottom, or a side of the camera, depending on how the camera is installed.
- You can monitor the camera's internal temperature by DeviceTemperature ([DeviceControl](#)).

Revision History

Revision	Date	Changes								
1.4	2025/10/22	Updated the note for the BiColor pixel formats based on the eBUS SDK 6.5.4 release (Pixel Format).								
1.3	2025/08/12	<p>Added the SW-4005BL-5GE model.</p> <p>The following topics were updated / added to include SW-4005BL-5GE: "Certifications", "China RoHS", "ROI (Regional Scanning Function)", "Binning Function", "Pixel Format", "Maximum Line Rates (Approximate)", "Actual Exposure Time", "Timing Chart", "Shading Correction", "Crosstalk Compensation Mode", "Spatial Compensation", "Specifications", "Spectral Response (Color model)"</p> <table border="1"> <thead> <tr> <th>SW-2005TL</th> <th>SW-2005M</th> <th>SW-4005BL</th> <th>SW-4005M</th> </tr> </thead> <tbody> <tr> <td>DV0103</td> <td>DV0103</td> <td>DV0101</td> <td>DV0100</td> </tr> </tbody> </table>	SW-2005TL	SW-2005M	SW-4005BL	SW-4005M	DV0103	DV0103	DV0101	DV0100
SW-2005TL	SW-2005M	SW-4005BL	SW-4005M							
DV0103	DV0103	DV0101	DV0100							
1.2	2025/06/24	<p>Added the SW-4005M-5GE model.</p> <p>The following topics were updated to include SW-4005M-5GE: "Certifications", "China RoHS", "ROI (Regional Scanning Function)", "Binning Function", "Pixel Format", "Maximum Line Rates (Approximate)", "Actual Exposure Time", "Timing Chart", "Shading Correction", "Specifications", "Spectral Response (Monochrome model)"</p> <table border="1"> <thead> <tr> <th>SW-2005TL</th> <th>SW-2005M</th> <th>SW-4005M</th> </tr> </thead> <tbody> <tr> <td>DV0103</td> <td>DV0103</td> <td>DV0100</td> </tr> </tbody> </table>	SW-2005TL	SW-2005M	SW-4005M	DV0103	DV0103	DV0100		
SW-2005TL	SW-2005M	SW-4005M								
DV0103	DV0103	DV0100								
1.1	2025/06/06	<p>Added the following topics: "Sensor Gain Mode", "Image Flip Function (ReverseX)", "LineSource Items", "Appendix"</p> <p>Revised the following topics: "Pixel Format", "Event Control Function (added a caution)"</p> <table border="1"> <thead> <tr> <th>SW-2005TL</th> <th>SW-2005M</th> </tr> </thead> <tbody> <tr> <td>DV0103</td> <td>DV0103</td> </tr> </tbody> </table>	SW-2005TL	SW-2005M	DV0103	DV0103				
SW-2005TL	SW-2005M									
DV0103	DV0103									
1.0	2024/12/05	<p>First release (SW-2005TL-5GE and SW-2005M-5GE)</p> <table border="1"> <thead> <tr> <th>SW-2005TL</th> <th>SW-2005M</th> </tr> </thead> <tbody> <tr> <td>DV0102</td> <td>DV0102</td> </tr> </tbody> </table>	SW-2005TL	SW-2005M	DV0102	DV0102				
SW-2005TL	SW-2005M									
DV0102	DV0102									

Trademarks

Systems and product names described in this document are trademarks or registered trademarks of their respective owners. The ™ and ® symbols are not used in this document.



See the possibilities

Visit our website on www.jai.com