



VLIP-CTRL-MST



AV over IP Master Controller

User Manual

VL-UserManual_VLIP-CTRL-MST



HDMI®

HIGH-DEFINITION MULTIMEDIA INTERFACE

The terms HDMI, HDMI High-Definition Multimedia Interface, and the HDMI Logo are trademarks or registered trademarks of HDMI licensing Administrator, Inc.

Surge protection device recommended



This product includes sensitive electrical components that can be damaged by electrical spike, surges, shocks, or lightning strikes. To safeguard and prolong the lifespan of your equipment, it is highly recommended to use surge protection systems.

SAFETY PRECAUTIONS

Please read all instructions before attempting to unpack, install or operate this equipment and before connecting the power supply. Please keep the following in mind as you unpack and install this equipment:

- Always follow basic safety precautions to reduce the risk of fire, electrical shock and injury to persons.
- To prevent fire or shock hazard, do not expose the unit to rain, moisture or install this product near water.
- Never spill liquid of any kind on or into this product.
- Never push an object of any kind into this product through any openings or empty slots in the unit, as you may damage parts inside the unit.
- Do not attach the power supply cabling to building surfaces.
- Use only the supplied power supply unit (PSU). Do not use the PSU if it is damaged.
- Do not allow anything to rest on the power cabling or allow any weight to be placed upon it or any person walk on it.
- To protect the unit from overheating, do not block any vents or openings in the unit housing that provide ventilation and allow for sufficient space for air to circulate around the unit.
- Please completely disconnect the power when the unit is not in use to avoid wasting electricity.

Welcome, to the VigilLink User Manual!

Thank you for your purchase. At VigilLink, we prioritize the end-user experience by focusing on ease of use, ensuring our solutions are straightforward to install and program for our valued dealers. Our mission goes beyond product development; we aim to create a seamless experience for both integrators and end-users.

We value your feedback and would love to hear about your experience. Positive feedback reassures us that we have achieved our goals. If there are any areas where we have not met your expectations, we encourage you to reach out and share your thoughts so we can understand your experience and work to exceed your expectations in the future.

Thank you again for your purchase, and we look forward to hearing from you!

Mickey Park, Founder and CEO, VigilLink

CONTENTS

1. Introduction	1
2. Applications	1
3. Package Contents	2
4. System Requirements	2
5. Features	2
6. Operation Controls and Functions	3
6.1 Front Panel.....	3
6.2 Rear Panel	3
6.3 Remote Control.....	5
6.4 IR Cable Pinouts.....	5
6.5 RS-232 Pinout and Defaults	5
6.6 WebGUI Control	6
6.6.1 System Tab	8
6.6.2 Monitor & Control Tab.....	11
6.6.3 Settings Tab	21
6.6.4 Transmitter Tab	29
6.6.5 Receiver Tab	33
6.6.6 Scaling Tab.....	40
6.6.7 Video Wall Tab.....	41
6.7 Telnet Control.....	43
6.8 Serial and Telnet Commands.....	43
7. Connection Diagram	53
8. Specifications	54
8.1 Technical Specifications.....	54
8.2 Video Specifications	55
8.3 Cable Specifications.....	57
9. Acronyms	58

INTRODUCTION

This IP Master Controller is a powerful and flexible solution for controlling multiple AVoIP (Audio/Video over IP) based extenders within same network. The user only needs to install this unit into the same local network as the extenders (transmitters and receivers) to easily define and configure channel routing selections (including video, audio, and a variety of control interface types) using the WebGUI. Without the use of this centralized control unit, each transmitter and receiver pair would only be able to function in a point-to-point capacity.

Additionally, this unit supports controlling and configuring the matrix and video wall modes of connected AVoIP units. The settings of all connected transmitter/receiver units, including IP configuration, compatibility settings, and extender status are clearly displayed within the WebGUI. A trigger input interface is also provided to allow the easy addition of a remote control keypad, or other trigger-supporting products, which can be installed within a podium or table in a conference room or classroom. This interface can allow the user to activate stored macros with the simple press of a button. Standard control is available via WebGUI (remote or local), RS-232, Telnet and IR Remote.

APPLICATIONS

- Video/TV wall display and control
- Security surveillance and control
- Commercial advertising, display and control
- Home Theaters with Smart Home Controls
- Retail sales and demonstration

PACKAGE CONTENTS

- 1× IP Master Controller - AV over IP (1G)
- 1× 5V/2.5A DC Power Adapter
- 1× Terminal Block (3-pin)
- 3× Terminal Block (5-pin)
- 1× IR Extender Cable
- 1× Remote Control (CR-183)
- 1× Shockproof Feet (Set of 4)
- 1× Operation Manual

SYSTEM REQUIREMENTS

- An active network connection from a switch or router for control of compatible AV over IP devices.
- HDMI receiving equipment such as an HDTV or monitor for direct local control and monitoring.

FEATURES

- Enables the management and configuration of multiple compatible extenders through a single WebGUI
- Provides control over the independent routing of video, audio and control signals between all local compatible transmitters and receivers
- Control over matrix, video wall, and multiviewer modes using WebGUI macros
- WebGUI clearly displays the status of all connected transmitters and receivers, including IP address, channel selection, etc.
- Can generate serial commands to directly control an external serial-controllable device
- Can be powered by Ethernet switches supporting the IEEE 802.3af 2003 PoE standard (Optional)
- Trigger Control Keypad support for easy, single-button, macro activation (Optional)
- Standard control is available via WebGUI (remote or local), RS-232, Telnet, and IR Remote

OPERATION CONTROLS AND FUNCTIONS

Front Panel

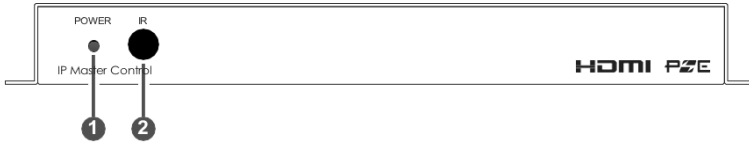

- 1 POWER LED:** This LED will illuminate to indicate the unit is on and receiving power.
- 2 IR Window:** Accepts IR signals from the included IR remote for control of this unit only.

Rear Panel

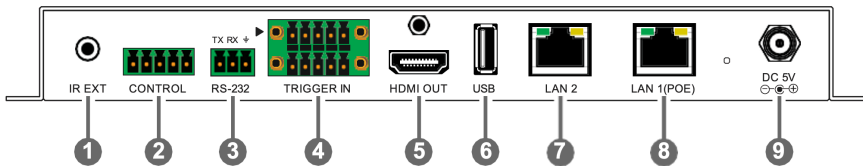

- 1 IR EXT Port:** Connect to the provided IR Extender to extend the IR control range of the unit. Ensure that the remote being used is within direct line-of-sight of the IR Extender.
- 2 CONTROL 5-pin Terminal Block:** Connect to a serial controllable device for the transmission of RS-232 signals.
- 3 RS-232 3-pin Terminal Block:** Connect to a PC, laptop or other serial control device with a 3-pin adapter cable to control the unit via RS-232.
- 4 TRIGGER IN 10-pin Terminal Block:** Connect to the Trigger Control Keypad (OPTIONAL) or any device with trigger switch functionality such as window security alarms, motion detectors, door switches, etc. Each of the 8 trigger inputs will activate the associated macro (1~8) when triggered.

Note: A minimum of 5V DC is required to activate each trigger.

- 5 HDMI OUT Port:** Connect to a standard HDMI display to view the unit's current status information and access the WebGUI directly without a PC.

Note: HDMI output is locked to a resolution of 1080p@60Hz.

- 6 USB Port:** Connect a USB mouse and keyboard to control the unit's WebGUI displayed on the HDMI output port. Firmware update via USB is also supported.

Note: Specialized USB control devices, such as a touch panel, should be connected before the unit is powered on.

- 7 LAN 2 Port:** Connect directly, or through a network switch, to your PC/laptop to control the unit via WebGUI/Telnet.

Note: This LAN port cannot support AutoIP devices and should ONLY be used for external control of the IP Master Controller itself.

- 8 LAN 1(PoE) Port:** This port is used to connect to the extension units to be controlled. Connect to the extension units' private network through their dedicated network switch, to enable detection and control over those units.

Note: If the connected network switch supports the IEEE 802.3af 2003 PoE (Power over Ethernet) standard, this unit can optionally be powered directly via this Ethernet port.

- 9 FACTORY RESET Pinhole:** Press and hold for 3 seconds to reset the unit to its factory defaults, including Ethernet settings.

Note: While the reset is in process, the LEDs on the front of the unit will flash. Once the reset is complete, the unit will return to normal operation.

- 10 DC 5V Port:** Plug the 5V DC power adapter into the unit and connect it to an AC wall outlet for power. (Optional, not required if the unit is powered via PoE).

Remote Control

- 1 **PRESET 1~8:** Press any of the 8 buttons to activate the saved preset associated with that number.

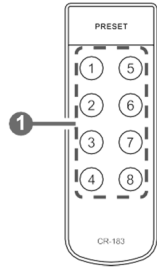

IR Cable Pinouts

IR
Extender
Cable

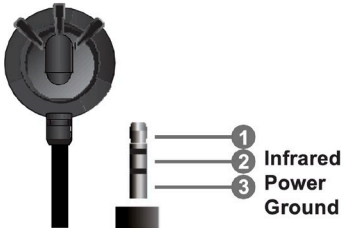

RS-232 Pinout and Defaults

Serial Port Default Settings	
Baud Rate	19200
Data Bits	8
Parity Bits	None
Stop Bits	1
Flow Control	None

Unit Control

3-pin Terminal
Block

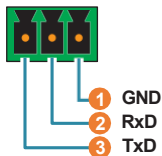

Serial Output

5-pin Terminal Block

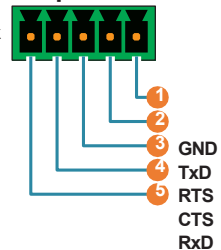

WebGUI Control

• Device Discovery

Please obtain the “Device Discovery” software from your authorized dealer and save it in a directory where you can easily find it.

Connect the unit and your PC/Laptop to the same active network and execute the “Device Discovery” software. Click on “Find Devices on Internet” and a list of devices connected to the local network will show up indicating their current IP address.

Note: The LAN 2 default IP address is 192.168.1.50. LAN 1 defaults to DHCP mode. The current IP address can be verified using the HDMI output or RS-232 if the Device Discovery software is not available.

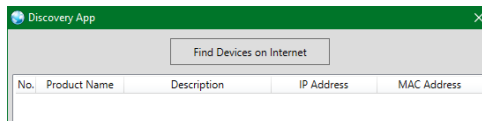

By clicking on one of the listed devices you will be presented with the network details of that particular device.

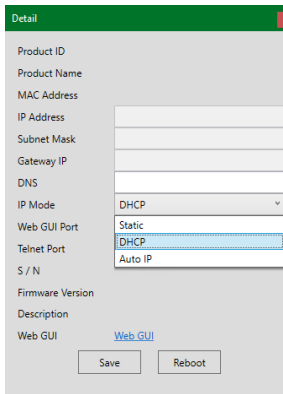

- 1) IP Mode:** If you choose, you can alter the static IP network settings for the device, or switch the unit into DHCP mode to automatically obtain proper network settings from a local DHCP server. To switch to DHCP mode, please select DHCP from the IP mode drop-down, then click “Save” followed by “Reboot”.
- 2) WebGUI Hotkey:** Once you are satisfied with the network settings, you may use them to connect via Telnet or WebGUI. The network information window provides a convenient link to launch the WebGUI directly.

• WebGUI Overview

After connecting to the WebGUI's address in a web browser, the WebGUI will load and display the Monitor & Control tab and basic routing functions can be controlled from here without logging in. However, to gain full control over the unit, switch to the System tab and click on the "Login" button to open the authentication window. Enter the appropriate user name and password then click "Enter" to log in. If a keyboard is not available, such as when using a touch screen, an on-screen keyboard can be enabled or disabled by clicking on the keyboard icon (⌨️). When enabled, the on screen keyboard will display whenever editing a text entry field. The interface language may also be changed by selecting a new language from the "Language" dropdown.

Note: The default user name and password is "admin".

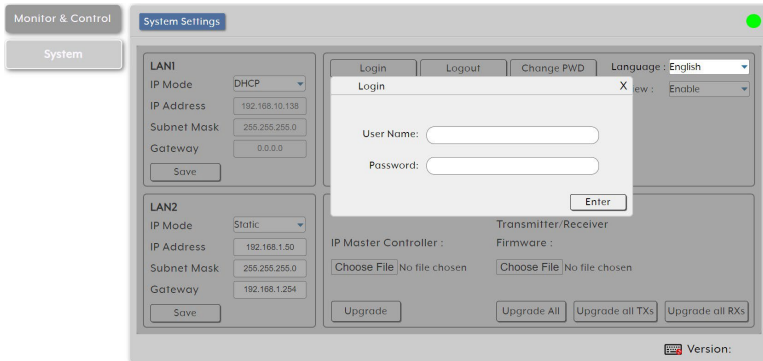

After logging in, on the left side of the browser you will see the following menu tabs where all primary functions of the unit are controllable via the built in WebGUI. These functions will be introduced in the following sections.

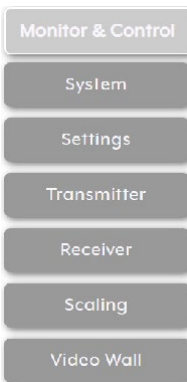

Clicking the "Logout" button within the "System" tab will log the currently connected user out of the WebGUI and return to login page.

Note: When not logged in, only the "Monitor & Control" and "System" tabs are visible.

1.1.1 System Tab

This tab provides access to system configuration options including IP configuration for both LAN ports, interface language, preview control, login and user management, and firmware update functionality.

The screenshot shows the 'System Settings' web interface. On the left is a sidebar with navigation buttons: Monitor & Control, System, Settings, Transmitter, Receiver, Scaling, and Video Wall. The main content area is titled 'System Settings' and contains several configuration panels. The 'LAN1' panel has fields for IP Mode (DHCP), IP Address (169.254.5.138), Subnet Mask (255.255.0.0), and Gateway (0.0.0.0), with a 'Save' button. The 'LAN2' panel has fields for IP Mode (DHCP), IP Address (192.168.10.137), Subnet Mask (255.255.255.0), and Gateway (192.168.10.1), with a 'Save' button. The 'System Commands' panel includes buttons for Login, Logout, Change PWD, Save Config, Upload Config, Save Log, Factory Reset, Reset all TXs, Reset all RXs, Reboot System, Reboot all TXs, and Reboot all RXs. It also shows 'Language: English', 'Preview: Enable', and 'User Account Enable: [checkbox]'. The 'Firmware Upgrade' panel has 'IP Master Controller' and 'Firmware' sections, each with a 'Choose File' button and an 'Upgrade All' button. A 'Version:' label is at the bottom right.

- 1) **LAN 1 & LAN 2:** The IP mode for each LAN port (DHCP or Static IP), IP address, netmask, and gateway can be set here. When a LAN port is set to “DHCP” mode, it will automatically attempt to obtain proper configuration information from the local DHCP server. To configure the network settings manually, please set the LAN port to “Static IP” mode and enter the information as appropriate for the connected network. Press “Save” to activate the changes. The MAC address for each port is also displayed here.

Note: If the devices being controlled have been set to “AutoIP” mode then LAN 1 should be set to DHCP. With no DHCP server available, LAN 1 will automatically assign itself an APIPA address from the 169.254.xxx.xxx range allowing it to discover and control AutoIP devices.

2) System Commands:

- **Login/Logout:** Click these buttons to log into or out of the WebGUI interface.

Note: When not logged in, only the “Monitor & Control” and “System” tabs are available.

- **Change PWD:** Click this button to change the WebGUI’s administrator login password.

Note: The default administrator user name and password is “admin”. The administrator user name cannot be changed.

- **Save Config:** The current system configuration may be saved as a *.bin file to the local PC. Click the “Save Config” button to save the current system configuration to your local PC.

- **Upload Config:** The system configuration may be restored from a previously saved *.bin file. Click the “Choose File” button to locate the saved *.bin file, then click the “Open” button.
- **Save Log:** A comprehensive system log file to help diagnose configuration issues or other problems can be generated, if requested by technical support. Click the “Save Log” button to save a copy of the current log data in, *.zip format, to your local PC.
Note: The generated file is password protected and is only intended for use by authorized technical support.
- **Language:** Use this dropdown to select the preferred display language for the unit’s WebGUI interface.
- **Preview:** Use this dropdown to enable or disable live preview thumbnail support on the Monitor & Control tab.
Note: In very large systems, disabling previews can save bandwidth and lessen the processing strain on the IP Master Controller.
- **Factory Reset:** Resets the unit back to its factory default settings.
Note: This Factory Reset does NOT clear the transmitter and receiver history tables. To completely remove old transmitter and receiver units from the system, use the “Remove” option on the Transmitter and Receiver tabs.
- **Reset all TXs/RXs:** Reset all detected transmitters or all detected receivers back to their factory default settings.
- **Reboot System:** Reboot this unit.
- **Reboot all TXs/RXs:** Reboot all detected transmitters or all detected receivers.
- **User Account Enable:** Move the slide switch to enable or disable the use of additional users and advanced user management functionality.
Note: Please see section 6.6.3 for user management settings.
- **S/N:** Displays the unit’s serial number.

- 3) **Firmware Upgrade:** Provides a method to remotely update the firmware of this unit as well as to update the firmware of detected transmitters and receivers.

Note: The update process can take several minutes to complete, especially if there are a large number transmitters and receivers in the system. Please do not power off any units during their update process.

- **IP Master Controller Firmware:** To update the unit's firmware click the "Choose File" button to open the file selection window and then select an appropriate firmware update file (*.bin format) located on your local PC. After selecting the file, click the "Upgrade" button to begin the firmware update process. Once the firmware update process has completed the unit will reboot.
- **Kit Plugin:** Provides a way to upgrade the system with additional, optional, plugins such as additional interface languages. To upload a new plugin, click the "Choose File" button to locate the appropriate file on your local PC, then click the "Open" button.
- **Transmitter/Receiver Firmware:** To allow the IP Master Controller to remotely update the firmware of detected transmitters and receivers, click the "Choose File" button to open the file selection window and then select an appropriate firmware update file (*.apz format) located on your local PC. After selecting the file it will be uploaded into the system and an "Upload Complete" popup will be displayed once the process is complete. To update the firmware of ALL detected transmitters and receivers, click the "Upgrade All" button. This will begin the firmware update process on all transmitters and receivers. Once the firmware update process has completed the affected units will reboot. To update the firmware of an individual unit, go to the Device Settings of that unit within the Transmitter or Receiver tabs and select the "Firmware Update" system command.

Note: The transmitter/receiver firmware will be stored within the IP Master Controller after upload until the firmware is replaced with another file or the unit is factory reset.

1.1.2 Monitor & Control Tab

This tab provides easy to use drag-and-drop control over all basic routing functionality of the transmitters and receivers that have been detected within the local network. In all sections, except for the Video and USB sections, transmitters are represented by the source icon (📺) and receivers are represented by the display icon (📺). Each of this tab's sections control the routing of a different type of interface that can be found on most compatible transmitters, receivers or transceivers. These interfaces are: Video routing, Video Wall routing, Digital/LineIn/MicIn Audio routing, USB routing, IR routing, RS-232 routing, and Macro activation. This tab's controls are available even when a user is not logged in, providing basic control over routing without exposing system critical configuration areas.

Note: Units that were previously a part of the system, but are not currently detected will still be displayed, however they will have a disconnected icon (🔌) and cannot be used for routing.

- 1) **Video Routing:** Provides drag-and-drop control over the video routing between all detected transmitters and receivers. Each transmitter and receiver button will display a small, low framerate, video thumbnail to indicate what video is currently active.

Note: Certain operational modes and some transmitters and receivers may not support the video thumbnail feature. If linked routing for video is enabled on the target receiver, then all other linked routing enabled streams will also switch. See section 6.6.5 for linked routing settings.

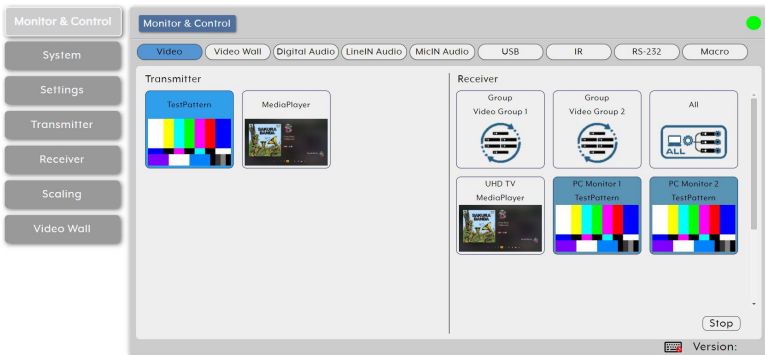

- **Video Transmitter:** This section provides drag-and-drop buttons for all transmitters detected by the system.
- **Source to Single Receiver Routing:** To route a source to a receiver, click and drag the source's button on the left to the preferred display



on the right side, then release the mouse button. If the routing was completed successfully, the newly routed source's name will appear below the display's name within the button. Clicking on any source button will change the color of itself, and all currently routed displays.

Note: Receivers may also be drag and dropped onto sources to activate a new route.

- **Source to Multiple Receiver Routing:** To route a source to multiple receivers at the same time, click and drag the source's button on the left to a pre-defined device group or "All" button on the right side, then release the mouse button. If the routing was completed successfully, the source's name will appear within the buttons of all appropriate displays.

Note: Device groups are defined within the Settings tab, please see section 6.6.3 for more information.

- **Video Receiver:** This section provides drag-and-drop buttons for all receivers detected by the system as well as display groups. A button target to disconnect incoming streams from one or more receivers is also provided.
- **Stop Stream:** To stop the video stream on a single display, drag the display down to the "Stop" button at the bottom of the window, then release the mouse button. To stop ALL video outputs, drag the "All" button down to the "Stop" button.
- **Status Icons:** Status icons will be displayed instead of a video thumbnail image under the following conditions:

 NO SIGNAL	Displayed when a transmitter or receiver's current input has no live source connected.
 SUPPORT	Displayed when a transmitter or receiver can't support the video thumbnail feature.
 OFFLINE	Displayed when a transmitter or receiver is offline or not currently detected by the IP Master Controller.

- 2) **Video Wall Routing:** Provides drag-and-drop source selection for predefined video wall groups.

Note: Video wall groups are defined within the Video Wall tab, please see section 6.6.7 for more information.

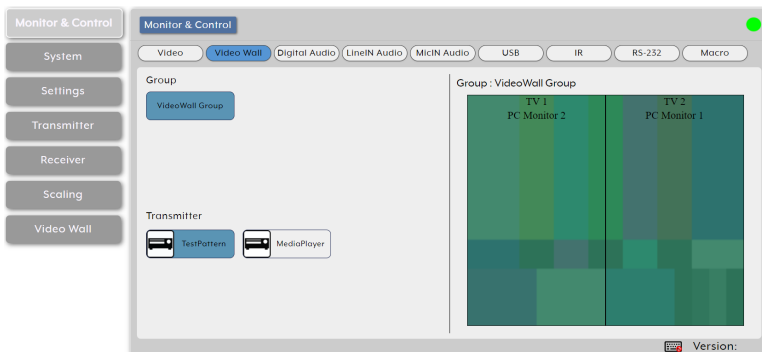

- **Group:** All currently defined video wall groups will be listed under the “Group” heading. Clicking on a group’s icon will display a simplified graphical representation of the video wall on the right side of the page in the Group View.
- **Transmitter:** All sources will be listed under the “Transmitter” heading. To assign a source to a video wall group, drag the transmitter to the preferred group or a group to the preferred transmitter.
Note: Linking a source to a previously inactive video wall group will automatically activate the video wall on all associated displays.
- **Group View:** Shows a simplified graphical representation of the currently selected video wall group. If the video wall is active the windows will be green and display a faded video thumbnail of the currently selected source. If one or more of the displays in the group is not currently active, those windows will be blue.

- 3) **Digital Audio Routing:** Provides drag-and-drop control over the independent routing of digital audio between all compatible transmitters and receivers. Digital audio sources include both HDMI and optical.

Note: If linked routing for audio is enabled on the target receiver, then all other linked routing enabled streams will also switch. See section 6.6.5 for linked routing settings.

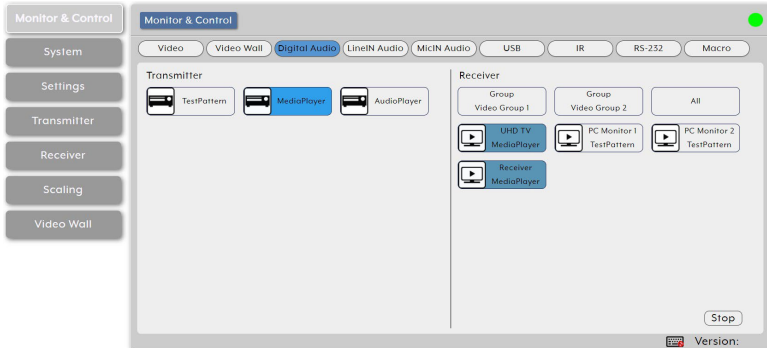

- **Digital Audio Transmitter:** This section provides drag-and-drop buttons for all transmitters with digital audio detected by the system.

Source to Single Receiver Routing: To route a transmitter's digital audio stream to a receiver, click and drag the source's button on the left to the preferred receiver on the right side, then release the mouse button. If the routing was completed successfully, the newly routed source's name will appear below the receiver's name within the button. Clicking on any source button will change the color of itself, and all currently routed receivers.

Note: Receivers may also be drag and dropped onto sources to activate a new route.

Source to Multiple Receiver Routing: To route a transmitter's digital audio stream to multiple receivers at the same time, click and drag the source's button on the left to a Group button or the "All" button on the right side, then release the mouse button. If the routing was completed successfully, the source's name will appear within all appropriate buttons.
- **Digital Audio Receiver:** This section provides drag-and-drop buttons for all digital audio supporting receivers detected by the system as well as a button target to stop digital audio streams.

Stop Stream: To stop the digital audio stream on a single receiver, drag the receiver down to the "Stop" button at the bottom of the window, then release the mouse button. To stop these audio streams on ALL receivers, drag the "All" button down to the "Stop" button.

- 4) **Line In Audio Routing:** Provides drag-and-drop control over the independent routing of Line In audio between all compatible transmitters and receivers.

Note: If linked routing for audio is enabled on the target receiver, then all other linked routing enabled streams will also switch. See section 6.6.5 for linked routing settings.

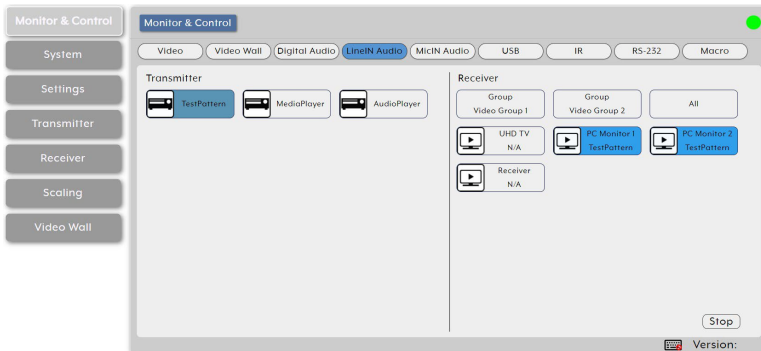

- **Line In Audio Transmitter:** This section provides drag-and-drop buttons for all transmitters with Line In audio detected by the system.
 - Source to Single Receiver Routing:** To route a transmitter's Line In audio stream to a receiver, click and drag the source's button on the left to the preferred receiver on the right side, then release the mouse button. If the routing was completed successfully, the newly routed source's name will appear below the receiver's name within the button. Clicking on any source button will change the color of itself, and all currently routed receivers.
 - Note: Receivers may also be drag and dropped onto sources to activate a new route.*
 - Source to Multiple Receiver Routing:** To route a transmitter's Line In audio stream to multiple receivers at the same time, click and drag the source's button on the left to a Group button or the "All" button on the right side, then release the mouse button. If the routing was completed successfully, the source's name will appear within all appropriate buttons.
- **Line In Audio Receiver:** This section provides drag-and-drop buttons for all Line In audio supporting receivers detected by the system as well as a button target to stop Line In audio streams.
 - Stop Stream:** To stop the Line In audio stream on a single receiver, drag the receiver down to the "Stop" button at the bottom of the window, then release the mouse button. To stop these audio streams on ALL receivers, drag the "All" button down to the "Stop" button.

- 5) **Mic In Audio Routing:** Provides drag-and-drop control over the independent routing of Mic In audio between all compatible transmitters and receivers.

Note: If linked routing for audio is enabled on the target receiver, then all other linked routing enabled streams will also switch. See section 6.6.5 for linked routing settings.

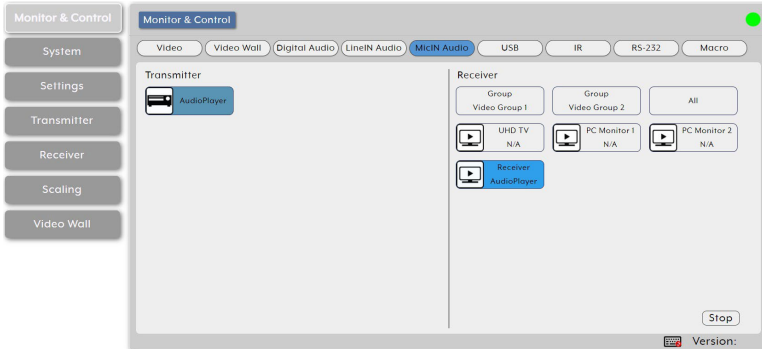

- **Mic In Audio Transmitter:** This section provides drag-and-drop buttons for all transmitters with Mic In audio detected by the system.

Source to Single Receiver Routing: To route a transmitter’s Mic In audio stream to a receiver, click and drag the source’s button on the left to the preferred receiver on the right side, then release the mouse button. If the routing was completed successfully, the newly routed source’s name will appear below the receiver’s name within the button. Clicking on any source button will change the color of itself, and all currently routed receivers.

Note: Receivers may also be drag and dropped onto sources to activate a new route.

Source to Multiple Receiver Routing: To route a transmitter’s Mic In audio stream to multiple receivers at the same time, click and drag the source’s button on the left to a Group button or the “All” button on the right side, then release the mouse button. If the routing was completed successfully, the source’s name will appear within all appropriate buttons.
- **Mic In Audio Receiver:** This section provides drag-and-drop buttons for all Mic In audio supporting receivers detected by the system as well as a button target to stop mic in audio streams.

Stop Stream: To stop the Mic In audio stream on a single receiver, drag the receiver down to the “Stop” button at the bottom of the window, then release the mouse button. To stop these audio streams on ALL receivers, drag the “All” button down to the “Stop” button.

- 6) **USB Pairing:** Provides drag-and-drop control over the pairing of USB hosts (PC, laptop, etc.) and USB devices (keyboard, mouse, webcam, etc.) between the ports detected on all transmitters and receivers.

Note: If linked routing for USB is enabled on the target receiver, then all other linked routing enabled streams will also switch. See section 6.6.5 for linked routing settings.



- **USB Host:** This section provides drag-and-drop buttons for detected USB host ports.

Host to Device Pairing: To pair a USB host with a USB device, click and drag the USB host's button on the left to the preferred USB device on the right side, then release the mouse button. If the pairing was completed successfully, the active USB host's name will appear below the USB device's name within the button. Clicking on any USB host button will change the color of itself, and all currently paired USB device endpoints.

Note: USB devices may also be drag and dropped onto USB hosts to activate a new pairing.

- **USB Device:** This section provides drag-and-drop buttons for all detected USB device endpoints as well as a button target to stop communication from a device.

Stop Device: To stop communication from a USB device, drag the USB device down to the "Stop" button at the bottom of the window, then release the mouse button.

- 7) **IR Routing:** Provides drag-and-drop control over the routing of the IR input and output pairs on all detected transmitters and receivers.

Note: If linked routing for IR is enabled on the target receiver, then all other linked routing enabled streams will also switch. See section 6.6.5 for linked routing settings.

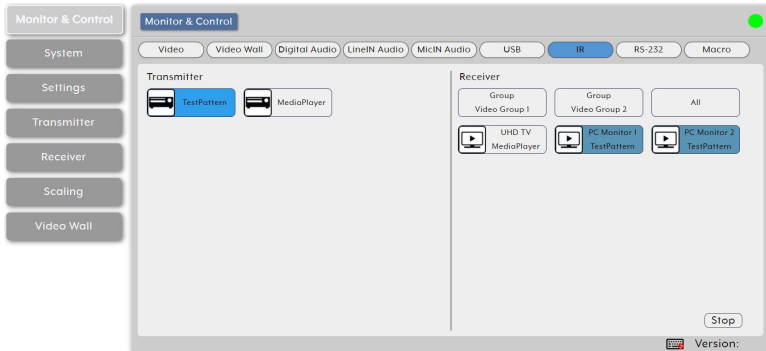

- **IR Transmitter:** This section provides drag-and-drop buttons for all transmitters with IR ports detected by the system.

Transmitter to Single Receiver Routing: To link a transmitter's IR input/output pair to a receiver's pair, click and drag the transmitter's button on the left to the preferred display on the right side, then release the mouse button. If the routing was completed successfully, the newly routed transmitter's name will appear below the display's name within the button. Clicking on any transmitter button will change the color of itself, and all currently routed displays.

Note: Receivers may also be drag and dropped onto sources to activate a new route.

Transmitter to Multiple Receiver Routing: To link a transmitter's IR input/output pair to multiple receivers at the same time, click and drag the source's button on the left to a Group button or the "All" button on the right side, then release the mouse button. If the routing was completed successfully, the transmitter's name will appear within all appropriate buttons.

- **IR Receiver:** This section provides drag-and-drop buttons for all receivers with IR ports detected by the system.

Stop Stream: To stop the IR stream on a single display, drag the display down to the "Stop" button at the bottom of the window, then release the mouse button. To stop IR streams on ALL video outputs, drag the "All" button down to the "Stop" button.

- 8) **RS-232 Routing:** Provides drag-and-drop control over the routing of the RS-232 ports on all detected transmitters and receivers.

Note: If linked routing for RS-232 is enabled on the target receiver, then all other linked routing enabled streams will also switch. See section 6.6.5 for linked routing settings.

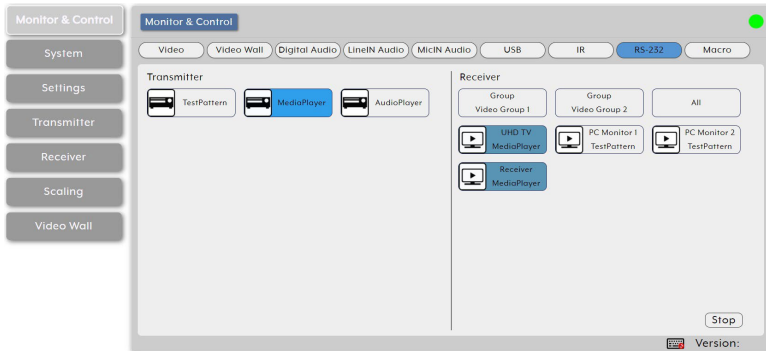

- **RS-232 Transmitter:** This section provides drag-and-drop buttons for all transmitters with RS-232 ports detected by the system.

Transmitter to Single Receiver Routing: To link a transmitter's RS-232 port to a receiver's port, click and drag the transmitter's button on the left to the preferred display on the right side, then release the mouse button. If the routing was completed successfully, the newly routed transmitter's name will appear below the display's name within the button. Clicking on any transmitter button will change the color of itself, and all currently routed displays.

Note: Receivers may also be drag and dropped onto sources to activate a new route.

Transmitter to Multiple Receiver Routing: To link a transmitter's RS-232 port to multiple receivers at the same time, click and drag the source's button on the left to a Group button or the "All" button on the right side, then release the mouse button. If the routing was completed successfully, the transmitter's name will appear within all appropriate buttons.

- **RS-232 Receiver:** This section provides drag-and-drop buttons for all receivers with RS-232 ports detected by the system.
- **Stop Stream:** To stop the RS-232 stream on a single display, drag the display down to the "Stop" button at the bottom of the window, then release the mouse button. To stop RS-232 streams on ALL video outputs, drag the "All" button down to the "Stop" button.

- 9) **Macro Activation:** Provides a simple interface to activate macros that have been pre-defined and stored within the IP Master Controller.

Note: See Section 6.6.3 for additional details on how to create macros.

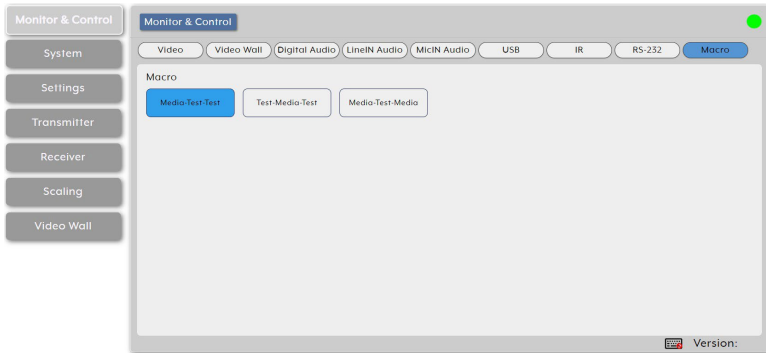

- **Macro:** All available macros will be listed in this section. To activate a macro, simply click on its button. The button will remain blue until the macro has completed executing.

Note: Only one macro can be executed at a time.

1.1.3 Settings Tab

This tab provides a way to configure a variety of the unit's different internal systems and interfaces including group and macro creation, I/O trigger assignment, setting the system's clock, event scheduling and SNMP support.

- 1) **Group:** This section provides a way to collect multiple receiving endpoints into single groups to be used as simple, single click, targets for routing A/V, USB or IR/RS-232 sources. Once created, each group will appear within the appropriate section of the Monitor & Control tab along with standard receivers.

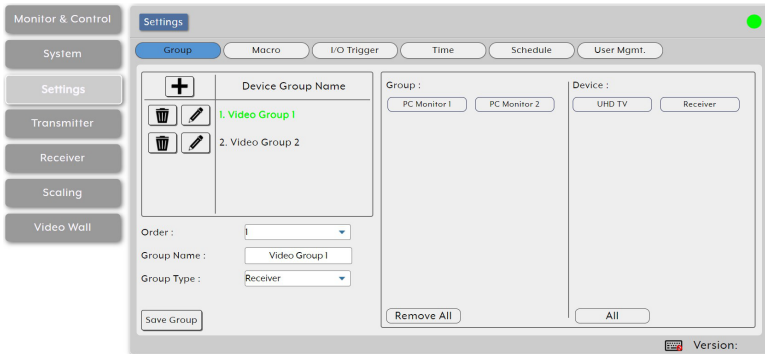

- **Device Group List:** The upper-left section contains a list of all currently defined groups and provides a way to create new groups, edit them, or delete them. The currently selected group will be highlighted in green. To add a new group, click on the “Add” icon (+) and then select the preferred options and endpoints. To edit an existing group, click on the “Edit” icon (✎) and then make whatever changes are required. Once a new or edited group has been configured, click on the “Save Group” button at the bottom of the page to store the group. To delete an existing group, click on the “Delete” icon (🗑) next to the appropriate group name.

Note: Leaving this screen before selecting “Save Group” will undo any changes made.

- **Order:** Use the dropdown to select the position within the group list for the currently selected group.

Note: The order in the list also impacts the order groups are displayed within the Monitor & Control tab.

- **Group Name:** Type the preferred name for the currently selected group.

- **Group Type:** Select the media type contained within this group. Currently the only option is: Receiver. This selection will determine the type of receiver endpoints available within the Device List.
 - **Group List:** This section contains all of the receiving endpoints that are assigned to the currently selected group. Clicking on an endpoint will remove it from the group and place it back in the “Device” section. To remove all devices from the current group, click on the “Remove All” button.
 - **Device List:** This section contains all of the available receiving endpoints for use in the currently selected group type. Clicking on an endpoint will move it into the “Group” section and add it to the group. To add all available receiver endpoints to the group, click on the “All” button.
- 2) **Macro:** This section provides a way to create operational command sequences that can be activated via the IR remote control, external triggers, or from within the WebGUI. Macros are a flexible and powerful tool. They can be as simple as selecting a new input for a receiver or a complex sequence of source, resolution, mode and audio changes executed in sequence. Up to 128 macros can be defined, and each macro can contain up to 64 commands.

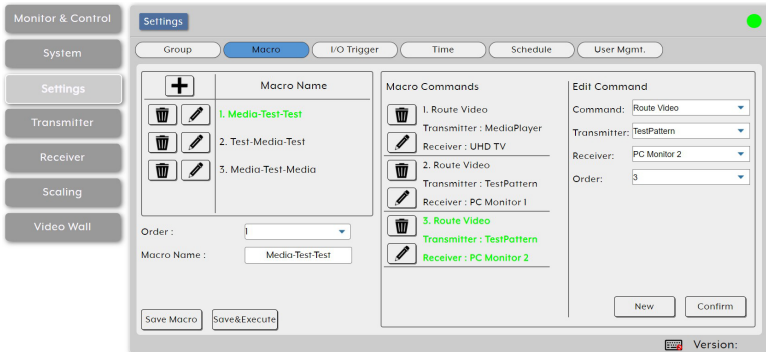

- **Macro List:** The upper-left section contains a list of all currently defined macros and provides a way to create new macros, edit them, or delete them. The currently selected macro will be highlighted in green. To add a new macro, click on the “Add” icon (+) and then create/add new commands for it in the window to the right. To edit an existing macro, click on the “Edit” icon (✎) and then make whatever changes are required. Once a new or edited macro has been configured, click on the “Save Macro” button at the bottom of the page to store the macro. To delete an existing macro, click on the “Delete” icon (🗑️) next to the appropriate macro name. To save and immediately

execute the currently selected macro, click the “Save & Execute” button.

Note: Leaving this screen before selecting “Save Macro” or “Save & Execute” will undo any changes made.

- **Order:** Use the dropdown to select the position within the macro list for the currently selected macro.

Note: The order in the list also impacts the order macros are listed within the Monitor & Control tab and when assigning IR remote and trigger functionality.

- **Macro Name:** Type the preferred name of the currently selected macro.
- **Macro Command List:** This section contains a list of all currently assigned commands within the macro and their execution order. To edit an existing command, click on the “Edit” icon (✎) and then make whatever changes are required in the right-hand panel. To create a new macro command, click on the “New” button at the bottom right side of the window and then configure it as preferred in the right-hand panel. Once a command has been edited, click on the “Confirm/Add” button at the bottom of the page to store the command in the macro. To delete an existing command, click on the “Delete” icon (🗑) next to the appropriate command.

Note: Clicking on “Confirm” or “Add” only stores the current changes to the command list of the macro currently being edited. The entire macro still needs to be saved by using the “Save Macro”. Leaving this screen before selecting “Save Macro” will undo any changes made.

- **New/Edit Command Details:** This section contains the details of the command currently being edited or created.
 - **Command:** Use the dropdown to select from the available macro command types.
 - **Object 1 (contextual):** Use the dropdown to select the first component this command will affect. Typically this will be a transmitter, but the objects listed depend upon the specific requirements of the selected command.
 - **Object 2 (contextual):** Use the dropdown to select the second component this command will affect. Typically this will be a receiver, but the objects listed depend upon the specific requirements of the selected command.
 - **Order:** Use the dropdown to select this command’s position within the command list for the currently selected macro.

- 3) **I/O Trigger:** This section provides a way to assign macros to each of the 8 trigger inputs on the unit as well as to the 8 IR remote buttons.

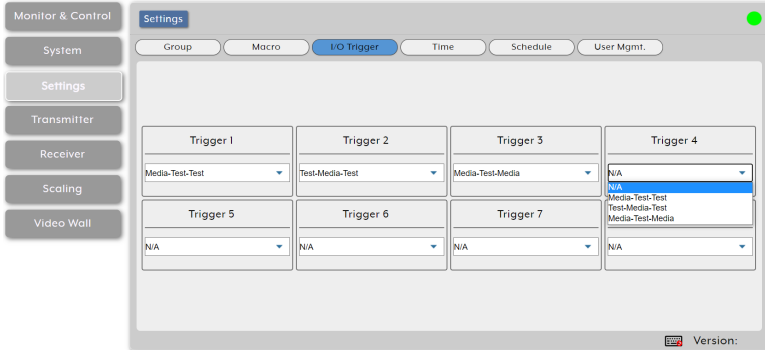

- **Trigger 1~8:** use the dropdowns to select the macro to assign to each trigger pin on the unit.

Note: The IR remote button number assignments will match the trigger assignments.

- 4) **Time:** This section provides a way to automatically set and sync the unit's system clock using a standard internet NTP (Network Time Protocol) server.

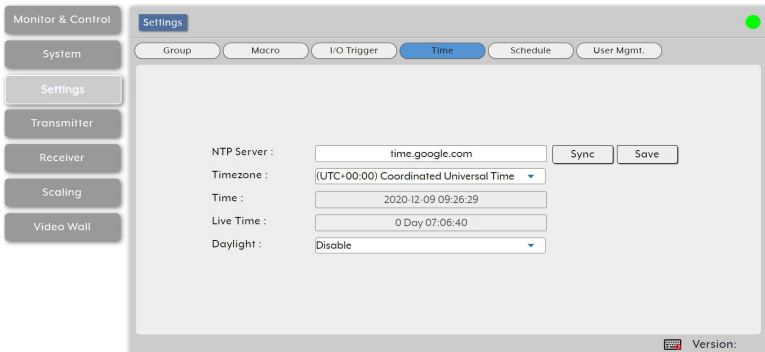

- **NTP Server:** Enter the hostname or IP address of the preferred NTP server to use for time synchronization. After changing the NTP server, click the “Save” button to store the new information. Click the “Sync” button to force the unit to sync to the NTP server immediately.

Note: This unit's clock does not have a battery backup, so time is not kept if the unit is unplugged. However, the time will automatically sync at power up as long as an internet connection is available and the NTP server is valid.

- **Timezone:** Use the dropdown to select your local time zone.
 - **Time:** Shows the unit's current time.
 - **Live Time:** Shows the length of time the unit has been online since the last reboot.
 - **Daylight:** Enable or disable support for daylight savings time.
- 5) **Schedule:** This section provides access to the settings and controls for configuring scheduled execution of macros. A macro can be scheduled to execute once at a specific time and date, on a periodic rotation, or at set times on specific days of the week.

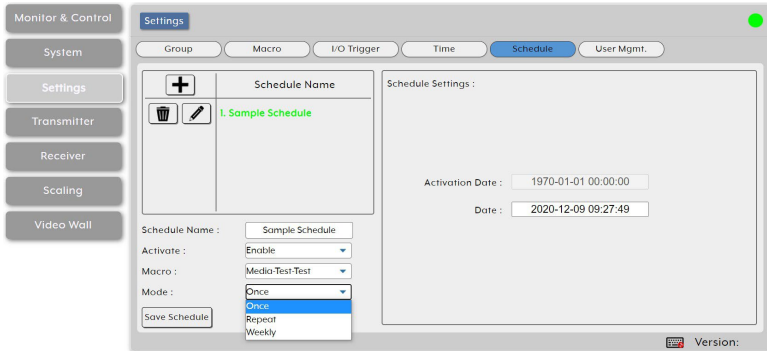

- **Schedule List:** The upper-left section contains a list of all currently defined schedule events and provides a way to create new schedule events, edit them, or delete them. The currently selected schedule will be highlighted in green. To add a new schedule event, click on the “Add” icon (✚) and then select the preferred options. To edit an existing schedule event, click on the “Edit” icon (✎) and then make whatever changes are required. Once a new or edited schedule has been configured, click on the “Save Schedule” button at the bottom of the page to store the schedule event. To delete an existing schedule event, click on the “Delete” icon (🗑️) next to the appropriate schedule event name.

Note: Leaving this screen before selecting “Save Schedule” will undo any changes made.

- **Schedule Name:** Enter the preferred name for the current schedule event.
- **Activate:** Use the dropdown to enable or disable the current schedule event.
- **Macro:** Use the dropdown to select the macro to activate at the scheduled time.

- **Mode:** Used the dropdown to select the scheduling style for the current schedule event.
 - **Once:** Select “Once” to execute the selected macro a single time on a specified day. After the configuration is complete, click on the “Save Schedule” button at the bottom of the page to store the schedule event.

Activation Date : 1970-01-01 00:00:00

Date : 2020-12-09 09:27:49

Date: Clicking on the date field will open the calendar entry window. Select the preferred day and time for the single activation and then click “Done”. Clicking the “Now” button will jump the entry field to the current time.

December 2020

Su	Mo	Tu	We	Th	Fr	Sa
		1	2	3	4	5
6	7	8	9	10	11	12
13	14	15	16	17	18	19
20	21	22	23	24	25	26
27	28	29	30	31		

Time 09:27:49

Hour

Minute

Second

- **Repeat:** Select “Repeat” to execute the selected macro on a regularly timed schedule starting at a specified time on a specified day. After the configuration is complete, click on the “Save Schedule” button at the bottom of the page to store the schedule event.

Activation Date : 2020-12-09 17:37:50

Time Interval : 3 Day 09:27:50

Times : 0

0 is unlimited, 1~N is times

Activation Date: The activation date is the date and time of the first execution of the macro. Clicking on the date field will open the calendar entry window. Select the preferred day and time and then click “Done”. Clicking the “Now” button will jump the entry field to the current time.

Time Interval: Enter the length of time to wait between executions of the macro in days, hours, minutes and seconds. Clicking on the time field will open the “Choose Time” window to make setting a length of time easier.

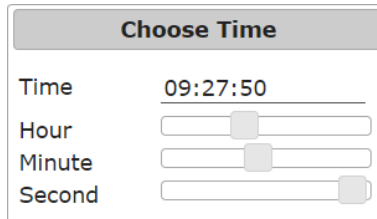

Times: Enter the number of times the schedule event should repeat. Entering “0” will make the event continually repeat.

- **Weekly:** Select “Weekly” to execute the selected macro at a specific time on set days of the week. After the configuration is complete, click on the “Save Schedule” button at the bottom of the page to store the schedule event.

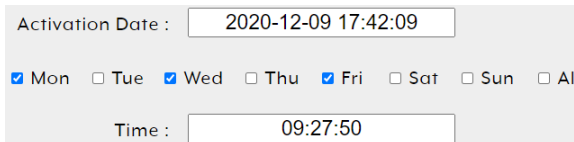

Activation Date: The activation date is the date and time of the first execution of the macro. Clicking on the date field will open the calendar entry window. Select the preferred day and time and then click “Done”. Clicking the “Now” button will jump the entry field to the current time.

Day Selection: Use the check boxes to select which days of the week the macro should execute on.

Time: Enter the time to execute the macro on all selected days. Clicking on the time field will open the “Choose Time” window to make setting a time easier.

- **Save Schedule:** Click this button to save changes to the current schedule.

- 6) **User Mgmt.:** This tab allows the addition and configuration of standard users. The amount of access each user has to the system, and which sources and displays they can control, is independently configured.

Note: By default, the unit only has the built in admin account which has full system access.

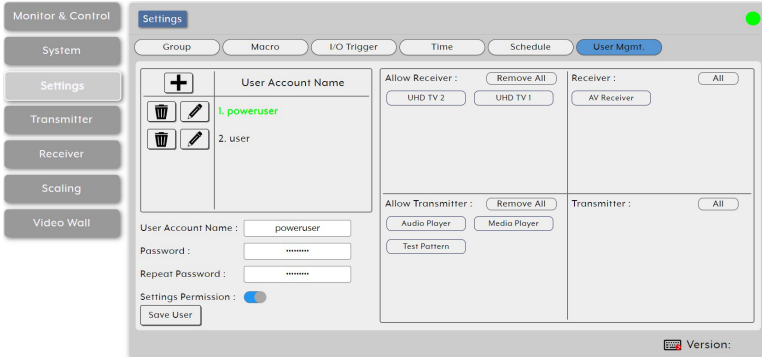

- **User Account Name List:** The upper-left section contains a list of all currently defined users and provides a way to create new users, edit them, or delete them. The currently selected user will be highlighted in green. To add a new user, click on the “Add” icon (+) and then select the preferred options, controllable devices, and password. To edit an existing user, click on the “Edit” icon (✎) and then make whatever changes are required. Once a new or edited user has been configured, click on the “Save User” button at the bottom of the page to store the user. To delete an existing user, click on the “Delete” icon (🗑️) next to the appropriate user name.

Note: Leaving this screen before selecting “Save User” will undo any changes made.

- **User Account Name:** Enter the preferred name for the currently selected user.
- **Password:** Enter the associated user’s login password in the primary entry field, they type the same password below in the “Repeat Password” field to confirm it.
- **Settings Permission:** Enable or disable the user’s access to the Settings, Transmitter, Receiver, Scaling and Video Wall tabs.
- **Allow Receiver List:** The left side of this section contains all of the receiving endpoints that are assigned to the currently selected user. Clicking on an endpoint will remove it from the user’s control and place it back in the “Receiver” section. To remove all receiver endpoints from the current user, click on the “Remove All” button.

- **Receiver List:** This section contains all of the available, but unassigned, receiving endpoints that the user can use. Clicking on an endpoint will move it into the “Allow Receiver” section and allow the user to control it. To add all available receiver endpoints to the user, click on the “All” button.
- **Allow Transmitter List:** The left side of this section contains all of the transmitting endpoints that are assigned to the currently selected user. Clicking on an endpoint will remove it from the user’s control and place it back in the “Transmitter” section. To remove all transmitting endpoints from the current user, click on the “Remove All” button.
- **Transmitter List:** This section contains all of the available, but unassigned, transmitting endpoints that the user can use. Clicking on an endpoint will move it into the “Allow Transmitter” section and allow the user to control it. To add all available transmitter endpoints to the user, click on the “All” button.

1.1.4 Transmitter Tab

This tab shows all transmitters that have been detected by the unit. Details about each transmitter’s name, IP address, and video content, as well as options to configure the network, RS-232, USB, and general device settings are also provided.

Note: Units that were previously a part of the system, but are not currently detected, will still be displayed; however, they will have a disconnected icon (🔌) and cannot be used for routing. These units may be removed from the list using the “Remove” button.

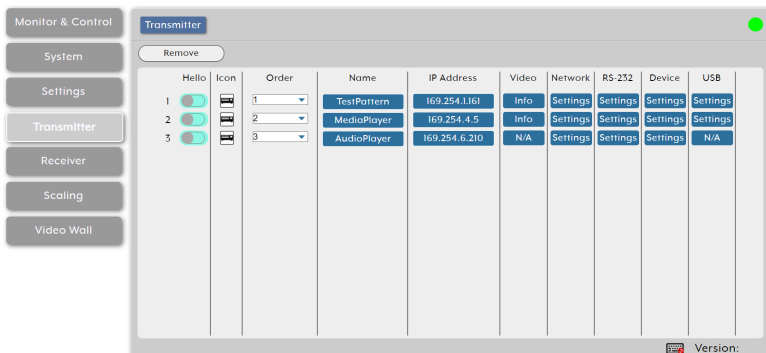

1) Transmitter Configuration:

- **Remove:** Click on this button to remove any transmitter from the list that has the disconnected icon (🔌). The pop-up window provides a dropdown to select the unit to be removed. Once the selection has

been made, click on “Confirm” to apply the change.

Note: Only disconnected transmitters can be removed here.

- **Hello:** Clicking on this switch will cause the selected unit to immediately begin flashing the LEDs on the front of the unit to make it easy to find. Clicking it a second time returns the LEDs to their normal behavior.

- **Icon:** Displays the icon used to represent the unit.

- **Order:** Use the dropdown to reorder the units in the list. Changing the order here will also change the order the units are listed in other tabs.

- **Name:** Displays each unit’s currently assigned name.

Note: The name can be changed within “Device Settings”.

- **IP Address:** Displays each unit’s current IP address.

- **Video Info:** Clicking this button, or hovering the mouse over it, will display a pop-up window containing detailed information about the current video source.

Note: If no live source is detected the button will turn red.

- **Network Settings:** Clicking this button will display a pop-up window containing detailed information about the unit’s current network settings, including IP mode, and allow for those settings to be changed. To activate any changes made, please click on the “Save” button to close the window.

- **RS-232 Settings:** Clicking this button will display a pop-up window containing detailed information about the unit’s current RS-232 settings, including baud rate, and allow for those settings to be changed. To activate any changes made, please click on the “Save” button to close the window.

Note: Linked transmitters and receivers must have the same serial settings.

- **Device Settings:** Hovering the mouse over this button displays a pop-up window with a summary of settings. Clicking on it provides controls over a number of unit-specific functions. See below for more detail.

- **USB Settings:** Clicking this button will display a pop-up window containing information about the unit’s current USB settings, including its current operational mode and compatibility settings. To activate any changes made, please click on the “Save” button to close the window.

- **Operation Mode:** Sets the USB extension mode. Available options are Auto Select Mode, Active On Link (Unicast optimized), and Active Per Request (Multicast optimized). Auto Select Mode is set by default and will automatically select the optimal mode depending on the casting mode of the unit.
- **K/M Over IP & Mouse Not Responding Well:** These troubleshooting options enable specialized optimizations to solve issues when a mouse or touch panel is not responding properly. They should normally be left disabled.

2) **Device Settings:** Clicking this button will display a pop-up window providing control over a number of important device settings and allow for those settings to be changed. To activate any changes made, please click on the “Save” button to close the window.

Note: The available options will change depending on the capabilities of the selected unit. Many setting changes will require the transmitter to be rebooted for the change to be fully implemented. If this is the case, there will be a popup notification.

The screenshot shows a settings window titled "Device (Media Player)" with a close button "X" in the top right corner. The settings are as follows:

- Version : (text field)
- System Command : N/A (dropdown menu)
- Name : Media Player (text field)
- Channel Select : 1 (dropdown menu)
- Casting Mode : Multicast (dropdown menu)
- Video Type : HDMI (dropdown menu)
- Max Frame Rate : 60 (dropdown menu)
- Bandwidth : Unlimited (dropdown menu)
- Audio Follow Video : Enable (dropdown menu)
- Audio Source : HDMI (dropdown menu)
- Audio Mute : (dropdown menu)
- Audio Volume : (slider)
- Video Auto Scan : Enable (dropdown menu)
- Front Panel Lock for Device Button : Disable (dropdown menu)
- Front Panel Lock for Device Knob : (dropdown menu)
- Save (button)

- **Version:** Display the unit’s current firmware version.
- **System Command:** Use the dropdown to select a system command to send to the unit. Typically available commands are:
 - **Factory Reset:** Reset the unit back to its factory default settings.

- **Reboot:** Reboot the unit.
- **Firmware Update:** Update the unit's firmware using the firmware version that has been pre-loaded into the IP Master Controller.

Note: See section 6.6.1 for firmware upload details.

- **Name:** Change the unit's name (12 character maximum).
- **Channel Select:** Use the dropdown to select the broadcast channel for the transmitter. All receivers on the local network that are set to the same channel will receive video from this transmitter. The available channel range is from 0 to 255.

Note: Every transmitter within the same local network must be assigned a different broadcast channel in order to avoid network conflicts.

- **Casting Mode:** Use the dropdown to select the networking mode used by the transmitter. Either multicast (one to many) or unicast (one to one) mode may be selected.

Note: Receivers must be set to the same casting mode as the transmitter in order to receive video.

- **Video Type:** Use the dropdown to select the video input on the unit to broadcast.
- **Max Frame Rate:** Set the maximum frame rate (in 1/60 steps) to use when encoding the source video.

Note: If the framerate is lowered too far with motion video sources, the video will become noticeably choppy.

- **Bandwidth:** Set the maximum bit rate that can be used by the video stream. Available options are: Unlimited, 400 Mbps, 200 Mbps, 100 Mbps, 50 Mbps. Selecting "Unlimited" will use up to the maximum available bandwidth in order to maintain a full framerate video stream.

Note: While it is generally suggested to select "Unlimited" when streaming 4K video sources, the amount of bandwidth required can be very large and will limit the number of concurrent video streams.

- **Audio Source:** Use the dropdown to select the audio source to embed in the outbound AVoIP stream. Selecting "HDMI" will always embed the current HDMI video's audio source, selecting "Line In" will always embed the Line In audio source, selecting "Auto" will embed the Line In source if it is connected and live.

Note: This setting is stored independently for each video input and is set to "Auto" by default.

- **Audio Mute:** Enable or disable muting the current audio source.
- **Audio Volume:** Set the volume level of the current audio source.
- **Video Auto Scan:** Enable or disable the “on video source loss” auto scan functionality of the transmitter.
- **Front Panel Lock for Device Button:** Enable or disable locking all front panel controls on the unit except the volume knob.
- **Front Panel Lock for Device Knob:** Enable or disable locking the volume knob on the front panel of the unit.
- **Save Button:** Press this button to save all device settings to the transmitter and exit the window.

1.1.5 Receiver Tab

This tab shows all receivers that have been detected by the unit. Details about each receiver’s name, IP address, and video content, as well as options to configure the network, RS-232, USB and general device settings are also provided.

Note: Units that were previously a part of the system, but are not currently detected, will still be displayed; however, they will have a disconnected icon (🔌) and cannot be used for routing. These units may be removed from the list using the “Remove” button.

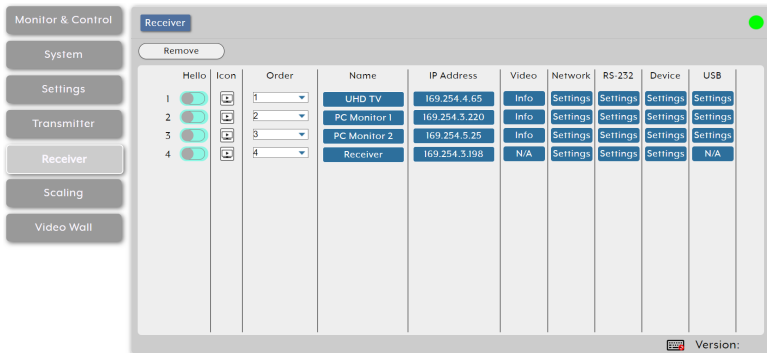

1) Receiver Configuration:

- **Remove:** Click on this button to remove any receiver from the list that has the disconnected icon (🔌). The pop-up window provides a dropdown to select the unit to be removed. Once the selection has been made, click on “Confirm” to apply the change.

Note: Only disconnected receivers can be removed.

- **Hello:** Clicking on this switch will cause the selected unit to immediately begin flashing the LEDs on the front of the unit to make it easy to find. Clicking it a second time returns the LEDs to their normal behavior.
- **Icon:** Displays the icon used to represent the unit.
- **Order:** Use the dropdown to reorder the units in the list. Changing the order here will also change the order the units are listed in other tabs.
- **Name:** Displays each unit's currently assigned name.
Note: The name can be changed within "Device Settings".
- **IP Address:** Displays each unit's current IP address.
- **Video Info:** Clicking this button, or hovering the mouse over it, will display a pop-up window containing detailed information about the current video output.
Note: If no display is detected the button will turn red.
- **Network Settings:** Clicking this button will display a pop-up window containing detailed information about the unit's current network settings, including IP mode, and allow for those settings to be changed. To activate any changes made, please click on the "Save" button to close the window.
- **RS-232 Settings:** Clicking this button will display a pop-up window containing detailed information about the unit's current RS-232 settings, including baud rate, and allow for those settings to be changed. To activate any changes made, please click on the "Save" button to close the window.
Note: Linked transmitters and receivers must have the same serial settings.
 - **Linked Routing:** Enable or disable linked routing for the RS-232 stream. When enabled, this stream type will automatically follow the routing selections of all other linked routing enabled stream types on this receiver.
 - **Enable Serial Over IP:** Enable or disable reception of RS-232 streams.
- **Device Settings:** Hovering the mouse over this button displays a pop-up window with a summary of settings. Clicking on it provides controls over a number of unit-specific functions. See below for more detail.
- **USB Settings:** Clicking this button will display a pop-up window containing information about the unit's current USB settings, including its current operational mode and compatibility settings. To activate any changes made, please click on the "Save" button to close the window.

- **Operation Mode:** Sets the USB extension mode. Available options are Auto Select Mode, Active On Link (Unicast optimized), and Active Per Request (Multicast optimized). Auto Select Mode is set by default and will automatically select the optimal mode depending on the casting mode of the unit.
- **K/M Over IP:** This troubleshooting option enables specialized optimizations to solve issues when a mouse or touch panel is not responding properly. They should normally be left disabled.
- **Linked Routing:** Enable or disable linked routing for the USB stream. When enabled, this stream type will automatically follow the routing selections of all other linked routing enabled stream types on this receiver.
- **Enable USB Over IP:** Enable or disable reception of USB streams.

2) **Device Settings:** Clicking this button will display a pop-up window providing control over a number of important device settings and allow for those settings to be changed. To activate any changes made, please click on the "Save" button to close the window.

Note: The available options will change depending on the capabilities of the selected unit. Many setting changes will require the receiver to be rebooted for the change to be fully implemented.

- **Version:** Display the unit's current firmware version.
- **System Command:** Use the dropdown to select a system command to send to the unit. Typically available commands are:
 - **Factory Reset:** Reset the unit back to its factory default settings.
 - **Reboot:** Reboot the unit.
 - **Firmware Update:** Update the unit's firmware using the firmware version that has been pre-loaded into the IP Master Controller.
Note: See section 6.6.1 for firmware upload details.
- **Name:** Change the unit's name (12 character maximum).
- **Casting Mode:** Use the dropdown to select the networking mode used by the receiver. Either multicast (one to many) or unicast (one to one) mode may be selected.
Note: Receivers must be set to the same casting mode as the transmitter in order to receive video.
- **Video Channel Lock for Device Button:** When this setting is enabled, the front panel "Ch +/-" buttons will be disabled.

- **Video Select Lock for Device Button:** When this setting is enabled, the front panel “Switch/Mode” button will be disabled.
- **Video Linked Routing:** Enable or disable linked routing for the video stream. When enabled, this stream type will automatically follow the routing selections of all other linked routing enabled stream types on this receiver.
- **Audio Linked Routing:** Enable or disable linked routing for the audio stream. When enabled, this stream type will automatically follow the routing selections of all other linked routing enabled stream types on this receiver.
- **IR Linked Routing:** Enable or disable linked routing for the IR stream. When enabled, this stream type will automatically follow the routing selections of all other linked routing enabled stream types on this receiver.
- **Timeout for Detecting Video Lost:** Use the drop down to set the length of time to wait for a lost source to return before showing the “Link Lost” screen. Available options are: 3, 5, 10, 20, 30, 60 seconds, or Never.
- **Turn Off Screen on Video Lost:** When enabled, the HDMI output will be completely disabled, including sync, after the video loss timeout time has expired. When disabled, the “Link Lost” screen will continue to be displayed until the connection returns.
- **Copy EDID From Sink:** When multiple receivers are connected to a single transmitter in multicast mode, enabling this on one receiver selects that receiver as the one which should send its EDID to the transmitter for use by the source.
Note: This option is only valid in multicast mode. Only one receiver, per transmitter, should have this checked at any one time to avoid potential conflicts.
- **Video Over IP:** Enable or disable the reception of all AVoIP streams completely.
Note: This option should always remain enabled unless troubleshooting is being performed.
- **Audio Mute:** Enable or disable muting the current audio output.
- **Audio Volume:** Control the volume level of the current audio output.
- **Front Panel Lock for Device Button:** Enable or disable locking all front panel controls on the unit except the volume knob.

- **Front Panel Lock for Device Knob:** Enable or disable locking the volume knob on the front panel of the unit.
- **Video Type:** Use the dropdown to select the video output's source.
Note: This option is only available on transceiver units.
- **Video Wall Button:** Pressing this button will open a new window to allow the direct configuration the current video wall settings of this receiver.
- **Save Button:** Press this button to save all device settings to the receiver and exit the window.

- **Column:** Set the horizontal location of the currently controlled receiver. (Counts left to right, from 0 to 15)
- **Row:** Set the vertical location of the currently controlled receiver. (Counts top to bottom, from 0 to 15)
- **Max Column:** Use the dropdown to define the number of displays in the video wall, measured horizontally. (Maximum is 16 displays)
- **Max Row:** Use the dropdown to define the number of displays in the video wall, measured vertically. (Maximum is 16 displays)
- **Bezel H/V Active & H/V Total:** This section is used to define the physical dimensions of all displays being used in the video wall. Accurate measurements are needed of the monitor's outer frame (H Total, V Total) and the video screen (H Active, V Active). The measurements may be made using any unit of measurement (inches, mm, cm, etc.) as long as ALL measurements within the same video wall are made using the exact same units and the numbers are integers.

Note: It is strongly recommended to use the same make and model for all displays within a video wall to avoid bezel and panel size discrepancies.

- **Rotate:** Set the rotation of the video output to 0, 180, or 270 degrees.
- **Aspect Ratio:** Set the video stretch method. Selecting “Full Screen” will expand the video to exactly fit the dimensions of the video wall regardless of the source’s original aspect ratio. Selecting “Best Fit” will zoom the video until the video wall is filled in all 4 dimensions while maintaining the aspect ratio of the original source.

1.1.6 Scaling Tab

This tab provides drag-and-drop control over the video output resolution of each receiver in the system.

Note: Due to this scaling occurring only on the receiver side, changes to resolutions here has no impact on bandwidth usage.

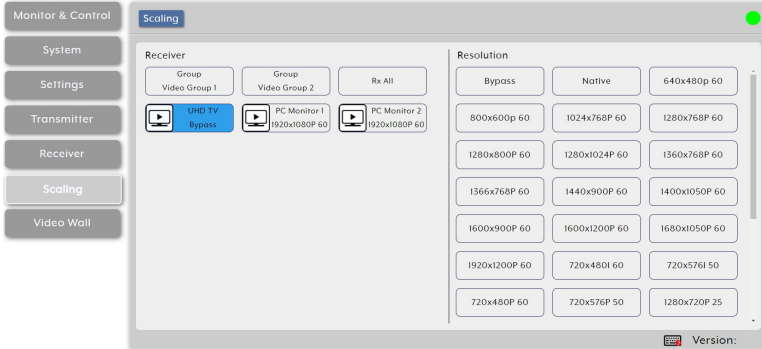

- 1) Resolution Selection:** To select an output resolution for a receiver, click and drag the receiver or receiver group's button on the left to the preferred resolution on the right side, then release the mouse button. If the selection was completed successfully, the new resolution will be displayed below each affected receiver's name. To change all receivers to the same resolution, drag the "Rx All" button to the preferred resolution on the right side. Selecting "Bypass" will force that receiver to output any routed source in its original resolution without scaling. Selecting "Native" will force that receiver to output using the native resolution provided by the connected display's EDID.

Note: Resolutions may also be drag and dropped onto receivers to change the output resolution.

1.1.7 Video Wall Tab

This tab provides a way to configure or modify video walls using multiple receivers in a group. All aspects of the video wall group can be configured here including dimensions (up to 16x16 displays), bezel compensation, display output resolution, and source.

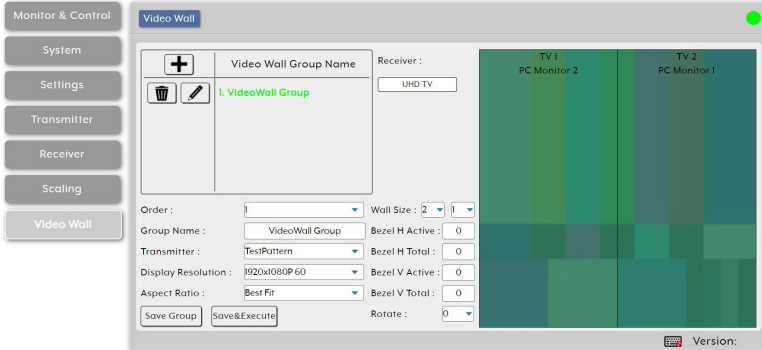

- Video Wall List:** The upper left section of this tab contains a list of all currently defined video wall groups in the system and provides a way to create new video walls, edit them, or delete them. The currently selected video wall group will be highlighted in green. To add a new video wall, click on the “Add” icon (+) and then select the preferred options and receivers. To edit an existing video wall group, click on the “Edit” icon (✎) and then make whatever changes are required. Once a new or edited video wall group has been configured, click on the “Save Group” button at the bottom of the page to store the group’s configuration. To save and immediately activate the current video wall group, click on the “Save & Execute” button. To delete an existing video wall group, click on the “Delete” icon (🗑) next to the appropriate group’s name.

Note: Deleting a video wall preset will not disable the video wall it described if it is currently active. To completely remove a video wall, new sources need to be routed to those displays from the Monitor & Control Tab.

- **Order:** Use the dropdown to reorder the video wall groups in the list. Changing the order here will also change the order the groups are listed in other tabs.
- **Group Name:** Set the name of the video wall group here.
- **Transmitter:** Select the transmitter to use as the video source for the video wall when the “Execute” button is used.

- **Display Resolution:** Select the resolution for all receivers in the video wall to output to their connected displays.
- **Aspect Ratio:** Set the video stretch method. Selecting “Full Screen” will expand the video to exactly fit the dimensions of the video wall regardless of the source’s original aspect ratio. Selecting “Best Fit” will zoom the video until the video wall is filled in all 4 dimensions while maintaining the aspect ratio of the original source.
- **Wall Size:** Select the size of the video wall, measured in number of monitors tall by number of monitors wide. The maximum number of displays in a single video wall is 256 (16x16).
- **Bezel H/V Active & H/V Total:** This section is used to define the physical dimensions of all displays being used in the video wall. Accurate measurements are needed of the monitor’s outer frame (H Total, V Total) and the video screen (H Active, V Active). The measurements may be made using any unit of measurement (inches, mm, cm, etc.) as long as ALL measurements within the same video wall are made using the exact same units and the numbers are integers.

Note: It is strongly recommended to use the same make and model for all displays within a video wall to avoid video distortions due to bezel and panel size discrepancies.

- **Rotate:** Set the rotation of the video output to 0, 180, or 270 degrees.
- **Receiver Selection:** This is a list of all available receivers in the system. Drag and drop each receiver to its correct position within the video wall grid to the right of the list. After placement, each receiver’s name will be displayed within the selected location of the video wall and it will turn red or green. Green panels within the video wall indicate that a display has been assigned and is in video wall mode, red panels indicate that a display has been assigned, but is not active or in the correct mode, and blue panels indicate that no display has been assigned yet.
- **Save Group:** Click this button to save changes to the current video wall configuration without executing or activating it.
- **Save & Execute:** Click this button to save changes to the current video wall configuration and then execute the changes. If the video wall was not already active, this will also activate it.

Telnet Control

Before attempting to use Telnet control, please ensure that both the unit and the PC are connected to the same active networks.

Start your preferred Telnet/Console client, or use the built in client provided by most modern computer operating systems. After starting the client, connect by using the current IP address of the unit and port 23 (if the communication port number used by the unit has not been changed previously). This will connect us to the unit we wish to control and commands may now be entered directly.

Note 1: If the IP address of the unit is changed then the IP address required for Telnet access will also change accordingly.

Note 2: This unit defaults to DHCP mode. The current IP address can be verified using the HDMI output or RS-232 if the Device Discovery software is not available. The default communication port is 23.

Serial and Telnet Commands

COMMAND	
Description and Parameters	
help ↵	Show the full command list.
help N1 ↵	Show details about the specified command. N1 = {Command}
? ↵	Show the full command list.
? N1 ↵	Show details about the specified command. N1 = {Command}
get fw ver ↵	Show the unit's current firmware version.
set factory default ↵	Reset the unit to the factory defaults.

COMMAND	
Description and Parameters	
get command ver ↵↵	Show the unit's current command version.
get model name ↵↵	Show the unit's model name.
get model type ↵↵	Show the unit's product type.
get mac N1 addr ↵↵	Show the MAC address of the specified LAN port. Available values for N1 : 1 [LAN port 1] 2 [LAN port 2]
set factory ipconfig default ↵↵	Reset the unit's network settings to the factory defaults.
set system reboot ↵↵	Reboot the unit.
set lan N1 ip mode N2 ↵↵	Set the IP address assignment mode of the specified LAN port. Available values for N1 : 1 [LAN Port 1] 2 [LAN Port 2] Available values for N2 : Static [Static IP mode] DHCP [DHCP mode]
get lan N1 ip mode ↵↵	Show the current IP address assignment mode of the specified LAN port. Available values for N1 : 1 [LAN Port 1] 2 [LAN Port 2]

COMMAND

Description and Parameters

get lan N1 ipconfig↵

Show the specified LAN port's current IP configuration information.

Available values for **N1**:

- | | |
|---|--------------|
| 1 | [LAN Port 1] |
| 2 | [LAN Port 2] |

get lan N1 ipaddr↵

Show the specified LAN port's current IP address.

Available values for **N1**:

- | | |
|---|--------------|
| 1 | [LAN Port 1] |
| 2 | [LAN Port 2] |

get lan N1 netmask↵

Show the specified LAN port's current netmask.

Available values for **N1**:

- | | |
|---|--------------|
| 1 | [LAN Port 1] |
| 2 | [LAN Port 2] |

get lan N1 gateway↵

Show the specified LAN port's current gateway address.

Available values for **N1**:

- | | |
|---|--------------|
| 1 | [LAN Port 1] |
| 2 | [LAN Port 2] |

set lan N1 static ipaddr N2↵

Set the specified LAN port's static IP address.

Available values for **N1**:

- | | |
|---|--------------|
| 1 | [LAN Port 1] |
| 2 | [LAN Port 2] |

N2 = X.X.X.X [X = 0~255, IP address]

get lan N1 static ipaddr↵

Show the specified LAN port's current static IP address.

Available values for **N1**:

- | | |
|---|--------------|
| 1 | [LAN Port 1] |
| 2 | [LAN Port 2] |

COMMAND

Description and Parameters

set lan N1 static netmask N2↵

Set the specified LAN port's static netmask.

Available values for **N1**:

- | | |
|---|--------------|
| 1 | [LAN Port 1] |
| 2 | [LAN Port 2] |

N2 = X.X.X.X [X = 0~255, netmask]

get lan N1 static netmask↵

Show the specified LAN port's current static netmask.

Available values for **N1**:

- | | |
|---|--------------|
| 1 | [LAN Port 1] |
| 2 | [LAN Port 2] |

set lan N1 static gateway N2↵

Set the specified LAN port's static gateway address.

Available values for **N1**:

- | | |
|---|--------------|
| 1 | [LAN Port 1] |
| 2 | [LAN Port 2] |

N2 = X.X.X.X [X = 0~255, gateway address]

get lan N1 static gateway↵

Show the specified LAN port's current static gateway address.

Available values for **N1**:

- | | |
|---|--------------|
| 1 | [LAN Port 1] |
| 2 | [LAN Port 2] |

get uart list↵

List all available serial ports.

set uart N1 reset↵

Reset the specified serial port's settings to the factory defaults.

Available values for **N1**:

- | | |
|---|---------------------|
| 1 | [3-pin serial port] |
| 2 | [5-pin serial port] |

COMMAND

Description and Parameters

set uart N1 baudrate N2↵

Set the baud rate of the specified serial port.

Available values for **N1**:

1	[3-pin serial port]
2	[5-pin serial port]

Available values for **N2**:

2400	[2400 baud]
4800	[4800 baud]
9600	[9600 baud]
19200	[19200 baud]
38400	[38400 baud]
57600	[57600 baud]
115200	[115200 baud]

get uart N1 baudrate↵

Show the current baud rate of the specified serial port.

Available values for **N1**:

1	[3-pin serial port]
2	[5-pin serial port]

set uart N1 stop bit N2↵

Set the number of stop bits for the specified serial port.

Available values for **N1**:

1	[3-pin serial port]
2	[5-pin serial port]

Available values for **N2**:

1	[1 stop bit]
2	[2 stop bits]

get uart N1 stop bit↵

Show the current number of stop bits for the specified serial port.

Available values for **N1**:

1	[3-pin serial port]
2	[5-pin serial port]

COMMAND

Description and Parameters

set uart N1 data bit N2↵

Set the data bits used by the specified serial port.

Available values for **N1**:

- | | |
|---|---------------------|
| 1 | [3-pin serial port] |
| 2 | [5-pin serial port] |

Available values for **N2**:

- | | |
|---|---------------|
| 7 | [7 data bits] |
| 8 | [8 data bits] |

get uart N1 data bit↵

Show the current number of data bits used by the specified serial port.

Available values for **N1**:

- | | |
|---|---------------------|
| 1 | [3-pin serial port] |
| 2 | [5-pin serial port] |

set uart N1 parity N2↵

Set the parity of the specified serial port.

Available values for **N1**:

- | | |
|---|---------------------|
| 1 | [3-pin serial port] |
| 2 | [5-pin serial port] |

Available values for **N2**:

- | | |
|---|--------|
| 0 | [None] |
| 1 | [Odd] |
| 2 | [Even] |

get uart N1 parity↵

Show the current parity setting of the specified serial port.

Available values for **N1**:

- | | |
|---|---------------------|
| 1 | [3-pin serial port] |
| 2 | [5-pin serial port] |

COMMAND

Description and Parameters

set uart 2 mode N1↵

Set the operational mode of the Control Output (5-pin) serial port.

Available values for **N1**:

0	[Disabled]
1	[RS-232 mode]
2	[RS-422 mode]
3	[RS-485 mode]

get uart 2 mode↵

Show the current operational mode of the Control Output (5-pin) serial port.

set uart 2 command [N1]↵

Transmit the specified command data via the Control Output (5-pin) serial port.

N1 = {Command data} [ASCII text]

Note: To transmit hex data, each ASCII hex pair (octet) must be preceded by “\x”. For example a carriage return would be “\x0D”.

set voip N1 audio out o1 route N2 N3↵

Route the specified transmitter’s audio input to the specified receiver’s audio output.

N1 = rx1~rx256 [Receiver device ID]

N2 = tx1~tx128 [Transmitter device ID]

Available values for **N3**:

1	[HDMI audio input]
2	[Analog audio input]

set all voip audio out o1 route N1 N2↵

Route the specified transmitter’s audio input to all receivers’ audio outputs.

N1 = tx1~tx128 [Transmitter device ID]

Available values for **N2**:

1	[HDMI audio input]
2	[Analog audio input]

COMMAND

Description and Parameters

set tx N1 uart 1 command [N2]↵

Transmit the specified command data via the serial port on the specified transmitter.

N1 = 1~128 [Transmitter device ID]

N2 = {Command data} [ASCII text]

Note: To transmit hex data, each ASCII hex pair (octet) must be preceded by “\x”. For example a carriage return would be “\x0D”.

set rx N1 uart 1 command [N2]↵

Transmit the specified command data via the serial port on the specified receiver.

N1 = 1~256 [Receiver device ID]

N2 = {Command data} [ASCII text]

Note: To transmit hex data, each ASCII hex pair (octet) must be preceded by “\x”. For example a carriage return would be “\x0D”.

set all tx uart command [N1]↵

Transmit the specified command data via the serial port on all transmitters.

N1 = {Command data} [ASCII text]

Note: To transmit hex data, each ASCII hex pair (octet) must be preceded by “\x”. For example a carriage return would be “\x0D”.

set all rx uart command [N1]↵

Transmit the specified command data via the serial port on all receivers.

N1 = {Command data} [ASCII text]

Note: To transmit hex data, each ASCII hex pair (octet) must be preceded by “\x”. For example a carriage return would be “\x0D”.

COMMAND

Description and Parameters

set voip N1 uart route N2 ←

Route the specified receiver's serial port Rx pin to the serial port Tx pin on the specified transmitter.

Available values for **N1**:

rx1~rx256

[Receiver device ID (Tx pin)]

Available values for **N2**:

tx1~tx128

[Transmitter device ID (Rx pin)]

set all voip uart route N1 ←

Route the specified transmitter's serial port Tx pin to the serial port Rx pins on all receivers.

Available values for **N1**:

tx1~tx128

[Transmitter device ID]

set voip N1 ir route N2 ←

Route the specified transmitter's IR input to the IR output on the specified receiver.

Available values for **N1**:

rx1~rx256

[Receiver device ID (IR output)]

Available values for **N2**:

tx1~tx128

[Transmitter device ID (IR input)]

set all voip ir route N1 ←

Route the specified transmitter's IR input to the IR outputs on all receivers.

Available values for **N1**:

tx1~tx128

[Transmitter device ID (IR input)]

COMMAND

Description and Parameters

set voip N1 usb device o1 route N2 1↵

Route the specified AVoIP device's USB device to the specified AVoIP device's USB host.

Available values for **N1**:

tx1~tx128

[Transmitter device ID (USB device)]

rx1~rx256

[Receiver device ID (USB device)]

Available values for **N2**:

tx1~tx128

[Transmitter device ID (USB host)]

rx1~rx256

[Receiver device ID (USB host)]

Note: Only transceiver units have both types of USB ports.

set video wall preset N1↵

Execute the specific video wall configuration.

N1 = 1~128

[Video wall group ID]

set macro N1 run↵

Execute the specified macro immediately.

N1 = 1~16

[Macro ID]

Note: Commands will not be executed unless followed by a carriage return. Commands are not case-sensitive.

CONNECTION DIAGRAM

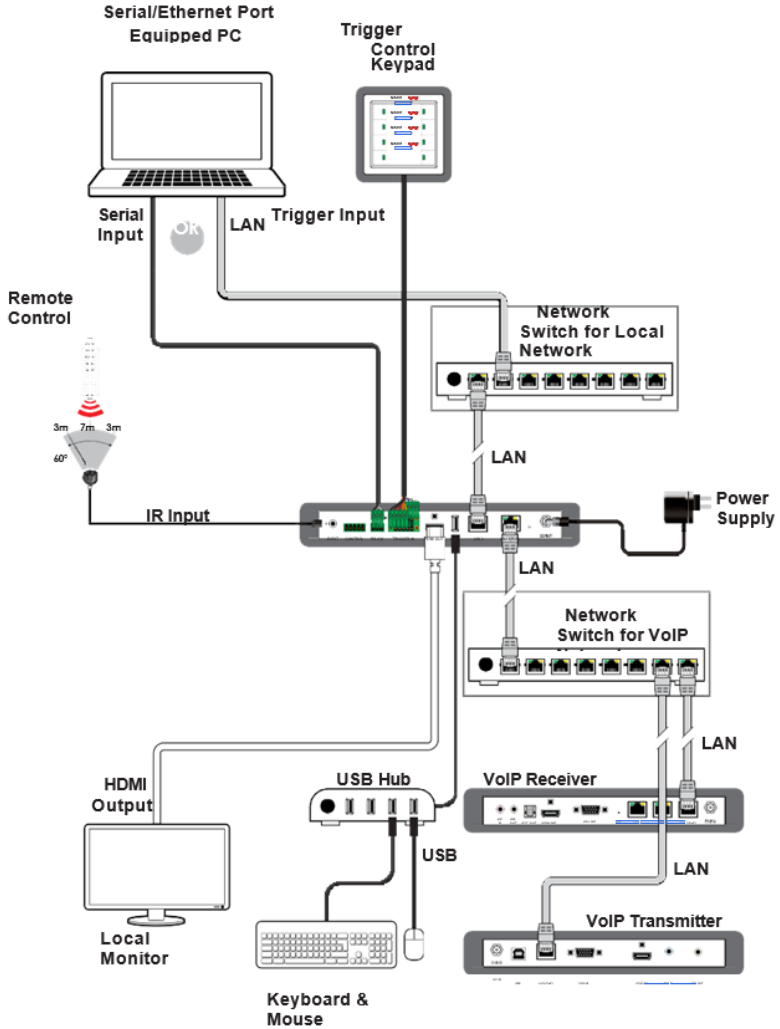

SPECIFICATIONS

Technical Specifications

HDMI Output Resolution	1920×1080@60Hz
Output Ports	1×HDMI (Type-A) 1×RS-232 (5-pin Terminal Block)
Control Ports	1×IR Extender (3.5mm) 1×RS-232 (3-pin Terminal Block) 8×Trigger (10-pin Terminal Block) 2×LAN (RJ-45) 1×USB 2.0 (Type A)
IR Frequency	38kHz
Baud Rate	19200
Power Supply	5V/2.6A DC (US/EU standards, CE/FCC/UL certified) or PoE (802.3af) from LAN Port 1
ESD Protection (HBM)	±8kV (Air Discharge) ±4kV (Contact Discharge)
Dimensions (W×H×D)	231.5mm×25mm×108mm [Case Only] 231.5mm×25mm×117mm [All Inclusive]
Weight	250g
Chassis Material	Metal (Steel)
Chassis Color	Black
Operating Temperature	0°C – 40°C/32°F – 104°F
Storage Temperature	-20°C – 60°C/-4°F – 140°F
Relative Humidity	20 – 90% RH (Non-condensing)
Power Consumption	2.99W

Video Specifications

Supported Resolutions (Hz)	Output
	HDMI
720×400p@70/85	×
640×480p@60/72/75/85	×
720×480i@60	×
720×480p@60	×
720×576i@50	×
720×576p@50	×
800×600p@56/60/72/75/85	×
848×480p@60	×
1024×768p@60/70/75/85	×
1152×864p@75	×
1280×720p@50/60	×
1280×768p@60/75/85	×
1280×800p@60/75/85	×
1280×960p@60/85	×
1280×1024p@60/75/85	×
1360×768p@60	×
1366×768p@60	×
1400×1050p@60	×
1440×900p@60/75	×
1600×900p@60RB	×
1600×1200p@60	×
1680×1050p@60	×
1920×1080i@50/60	×
1920×1080p@24/25/30	×
1920×1080p@50/60	60
1920×1200p@60RB	×

Supported Resolutions (Hz)	Output
	HDMI
2560×1440p@60RB	×
2560×1600p@60RB	×
2048×1080p@24/25/30	×
2048×1080p@50/60	×
3840×2160p@24/25/30	×
3840×2160p@50/60 (4:2:0)	×
3840×2160p@24, HDR10	×
3840×2160p@50/60 (4:2:0), HDR10	×
3840×2160p@50/60	×
4096×2160p@24/25/30	×
4096×2160p@50/60 (4:2:0)	×
4096×2160p@24, HDR10	×
4096×2160p@50/60 (4:2:0), HDR10	×
4096×2160p@50/60	×

Cable Specifications

Cable Length	1080p		4K30	4K60
	8-bit	12-bit	(4:4:4) 8-bit	(4:4:4) 8-bit
High Speed HDMI Cable				
HDMI Output	15m	x	x	x

Bandwidth Category Examples:

- **1080p (FHD Video)**
 - Up to 1080p@60Hz, 12-bit color
 - Data rates lower than 5.3Gbps or below 225MHz TMDS clock
- **4K30 (4K UHD Video)**
 - 4K@24/25/30Hz & 4K@50/60Hz (4:2:0), 8-bit color
 - Data rates higher than 5.3Gbps or above 225MHz TMDS clock but below 10.2Gbps
- **4K60 (4K UHD+ Video)**
 - 4K@50/60Hz (4:4:4, 8-bit)
 - 4K@50/60Hz (4:2:0, 10-bit HDR)
 - Data rates higher than 10.2Gbps

ACRONYMS

ACRONYM	COMPLETE TERM
10GbE	10 Gigabit Ethernet
ADC	Analog-to-Digital Converter
ASCII	American Standard Code for Information Interchange
AVoIP	Audio/Video over IP
AVR	Audio/Video Receiver or Recorder
Cat.5e	Enhanced Category 5 cable
Cat.6	Category 6 cable
Cat.6A	Augmented Category 6 cable
Cat.7	Category 7 cable
CLI	Command-Line Interface
DAC	Digital-to-Analog Converter
DHCP	Dynamic Host Configuration Protocol
DP	DisplayPort
EDID	Extended Display Identification Data
GbE	Gigabit Ethernet
GUI	Graphical User Interface
HDCP	High-bandwidth Digital Content Protection
HDMI	High-Definition Multimedia Interface
HDR	High Dynamic Range
HDTV	High-Definition Television
IGMP	Internet Group Management Protocol
IP	Internet Protocol
IR	Infrared
KVM	Keyboard/Video/Mouse
LAN	Local Area Network
LED	Light-Emitting Diode
LPCM	Linear Pulse-Code Modulation
MAC	Media Access Control

ACRONYM	COMPLETE TERM
OSD	On-Screen Display
PD	Powered Device
SDVoE	Software Defined Video over Ethernet
TCP	Transmission Control Protocol
4K UHD	4K Ultra-High-Definition (10.2Gbps max)
4K UHD+	4K Ultra-High-Definition (18Gbps max)
UHDTV	Ultra-High-Definition Television
USB	Universal Serial Bus
VLAN	Virtual LAN
VoIP	Video over IP
WUXGA (RB)	Widescreen Ultra Extended Graphics Array (Reduced Blanking)
XGA	Extended Graphics Array

For order support, please contact your Distributor or Reseller.

For technical support, check with the our website www.vigillink.com or contact info@vigillink.com



Headquarters
46 Corporate Park #130
Irvine, CA 92606
949-701-4742