

YASHICA

Digital Camera **City300**

User Manual

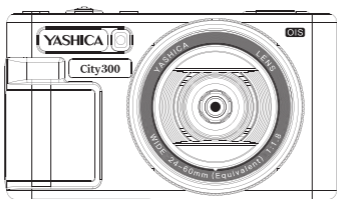

Contents

Safety Instructions	—————	P. 4
Getting Started	—————	P. 5 - 6
Product Overview	—————	P. 7 - 9
Display Overview	—————	P. 10 - 21
APP introduction	—————	P. 22 - 23
Troubleshooting	—————	P. 24
Specification	—————	P. 25
Disclaimer	—————	P. 26
Warranty Policy	—————	P. 27

Safety Instructions

Before operating this camera, please read and adhere to the following safety guidelines. Failure to comply with these instructions may result in damage to the camera.

Improper use of the battery can lead to explosions, fires, or chemical burns. To ensure safety, please follow these precautions:

1. **Do Not Disassemble:** Avoid short-circuiting the battery. Keep metal objects away from the battery terminals. Do not crush the battery pack or subject it to external forces such as impacts, drops, or pressure.
2. **Temperature Control:** Do not expose the battery to temperatures above 60 degrees Celsius. Keep it away from direct sunlight and avoid leaving it in a car that is exposed to heat.
3. **Proper Disposal:** Never burn or dispose of the battery in fire, and do not use damaged or leaking lithium-ion batteries.
4. **Child Safety:** Keep the battery out of children's reach and ensure it remains dry.
5. **Power Adapter Use:** Always connect the power adapter to the nearest wall outlet. If you encounter any issues, unplug the adapter immediately.

Important Notices

1. Electromagnetic waves at specific frequencies may impact image quality.
2. You can refer to this user manual and the quick start guide to get acquainted with the camera.
3. If the camera malfunctions, do not attempt to disassemble or repair it, contact YASHICA Customer Service Centre for assistance.
4. If the camera is not in use for an extended period, charge the camera to about 50% every three months to ensure the camera is fully charged before its first use.

Getting Started

Please read the manual carefully before use to ensure appropriate use of product functions.

Please keep this manual for future inquiries.



What is in YASHICA City 300 Digital Camera?

1. YASHICA City 300 Digital Camera
2. Storage Bag
3. User Manual
4. Type-C Charging Cable
5. Lens Cover
6. Hand Strap
7. Keychain
8. Cleaning Cloth
9. Warranty Card

First time using YASHICA City 300

Inserting Micro SD/TF Card

- Open the battery compartment cover to insert the Micro SD/TF Card into the Micro SD/TF Card slot.
- Close the battery compartment cover.

Important: Please check with your memory card, U3 level memory cards are recommended. Memory cards below U3 level are not guaranteed to work properly.

Remarks: Make sure the camera is turned off.

Product Overview

Installing battery

Install the battery into the camera according to the direction shown in the figure.

Low battery display: When the battery level is too low, the battery power icon in the upper right corner of the display will turn red. Please charge it in time.

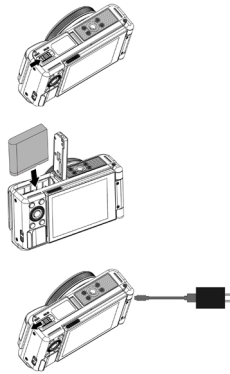

Charging YASHICA City 300

- Connect the Charging Cable to the USB Type-C Port.
- The charging indicator turns red while being charged. It will turn off when the camera is fully charged. Make sure the battery is installed properly.

Format the TF/Micro Card

- Format the TF/MicroSD Card in the camera. Press Menu Button and go to Format function, select OK to confirm.
- If there is any existing data in the TF/MicroSD card, please back up the data before formatting.

Attaching the hand strap

- Attach the hand strap to the hooks near the LED flashlight.

Attaching the lens cover and string

- Attach the lens cover to the hooks near the mic.

Attaching to the tripod

- Mount the camera to any tripods with 1/4"-20 thread mount for capturing the moments in photos or videos.

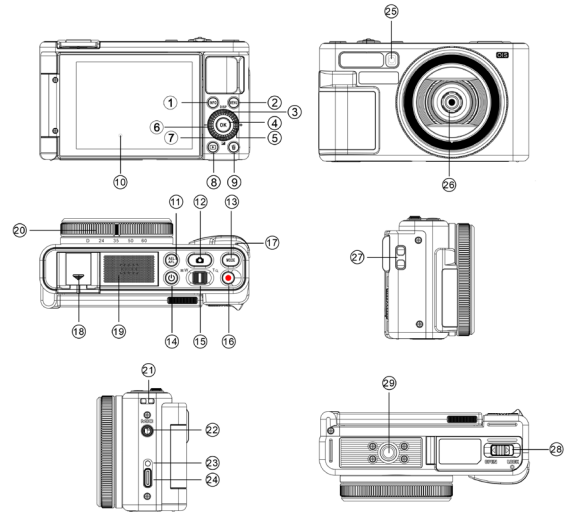

	Button	Function
1	INFO Button	For displaying the main function menu.
2	MENU Button	For accessing the function list.
3	Up Button (DISP)	For changing screen display mode; scrolling up in menus; increasing volume during video playback.
4	OK Button (Filter)	For opening filter shortcut menu; confirming selections in menus; replaying or pausing video.
5	Right Button (+)	For selecting right in menus; in P/S mode, adjusting EV/shutter settings; fast forwarding video playback by 2X.
6	Left Button (-)	For selecting left in menus; in P/S mode, adjusting EV/shutter settings; rewinding video playback by 2X.
7	Down Button (EV Setting)	For accessing EV shortcut menu; scrolling down in menu; decreasing volume during video playback
8	Playback Button	For entering/exiting playback mode; stopping video playback.
9	Delete Button	For quickly removing the last file.
10	Display	For showing lens preview and local video/photo playback.
11	AEL/AFL Button	For locking or unlocking current exposure and focus simultaneously.
12	Photo Button	Two-stage button; lightly press to focus in photo and video modes. Press again in photo mode to capture images. In other modes, press to quickly exit and preview.
13	Mode Button	For navigating and selecting from the shooting mode options.
14	Power Button	Press to turn the camera on or off.
15	W/T Zoom Switch	In video or photo mode, adjust the zoom by sliding the switch left or right. In playback mode, toggle the W terminal to access the thumbnail view. While viewing images, rotate the T terminal to zoom in for a closer look.
16	Video Button	For starting or stopping video recording.

17	Built in microphone	Video and audio recording.
18	Hot shoe Interface	For connecting an external dedicated flash.
19	Speaker Interface	For audio playback.
20	Focus Ring	Fixed focal segment adjustment ring, quick switching between D (D=Digital Zoom), 24mm, 35mm, 50mm, and 60mm.
21	Lens Cover Buckle	Secure the lens cover in place.
22	MIC Interface	For connecting an external microphone.
23	Charging Indicator Light	For illuminating during charging and turning off when fully charged.
24	USB-C Interface	For charging or connecting the camera to the computer
25	AF Assist Light	Red light, for aiding focusing in low-light conditions.
26	Camera Lens	For framing and viewing the scenes.
27	Wrist Buckle	For attaching the wrist strap securely.
28	Battery and Memory Card Compartment	For housing the battery and TF/Micro SD card.
29	1/4" Round Screw Hole	For tripod installation.

- Fixed focal length mode: 24mm corresponds to a camera resolution of effective resolution at 50MP, 35mm corresponds to a camera resolution of 24MP, 35mm corresponds to a camera resolution of 12MP, and 60mm corresponds to a camera resolution of 8MP; D (Digital Zoom) corresponds to a camera resolution of 50MP (The digital zoom function is not applicable in fixed focus mode.).
- As there is no LED light, you are recommended to pair your camera with a flash with the hot shoe. When using the flash, please select in the Menu button and select Flashlight and press fill flash function option.

Note: The flash cannot be activated during burst shooting or video modes.

Display Overview

Photo mode

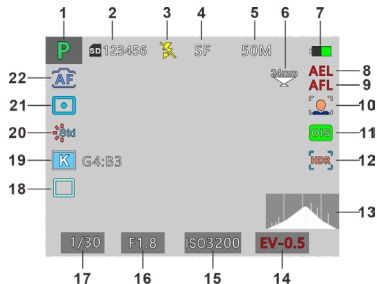

- | | |
|--|--|
| 1. Shooting mode | 12. Pixel Binning+HDR |
| 2. Remaining Photos | 13. Histogram |
| 3. Flash Status | 14. Exposure Compensation |
| 4. Image Quality | 15. ISO Sensitivity |
| 5. Photo Resolution | 16. Aperture Value |
| 6. Fixed focal segment Or W/T zoom bar | 17. Shutter Speed |
| 7. Battery Level | 18. Shooting Mode Options(Single/Continuous/Timed Photography) |
| 8. Exposure Lock | 19. White Balance (White Balance Offset) |
| 9. Focus Lock | 20. Filter |
| 10. Face Tracking | 21. Metering Mode |
| 11. Optical Image Stabilisation (OIS) | 22. Focus Mode |

- Press and hold the power button for 2 seconds to turn on the camera and access the main preview interface.
- Configure the desired functional options using the settings menu and camera mode.
- Gently press the shutter button to focus, and press it again to capture a photo.
- To begin recording, press the 'Record' button; press it once more to stop recording.

Photo Menu

To enter the photo menu, press the MENU button in the photo menu from the main preview interface. Then, press the down button followed by the right button, to access the photo menu directly. Use the up, down, left, and right buttons to navigate, press the OK button to confirm your selection, and use the MENU button to exit.

Name	Function
Shooting Modes (For photos/ videos)	Press MENU/MODE button to select: Program Mode Shutter Priority Scene Selection Standard Video Automatic Mode
Resolution	Press MENU button to select: 50MP / 24MP / 12MP (Enhance)
Quality	Press MENU button to select: Super Fine Fine Normal
Photo Ratio	Press MENU button to select: 4:3 16:9
Timestamp	Press MENU button to select: Off Date Date & Time
Focus modes	Press MENU button to select: • AF (Auto Focus) • RTAF (Real time focusing)
Face Tracking	On/Off
AF Assist Lamp	Off/Auto
White Balance	<ul style="list-style-type: none"> • Auto • Daylight • Cloudy • Color Temperature (Press mode to choose between 3000K and 9000K) • Tungsten Light • Fluorescent (High) • Fluorescent (Low)

Name	Function
Filter	<ul style="list-style-type: none"> • Standard • Natural • Vivid • Monotone • High Contrast B&W • Negative • High Contrast • Retro • Vintage • Warm Tone • Cold Tone • Red Tone • Green Tone • Blue Tone • Yellow Tone
Beauty	On/Off
HDR	On/Off
Exposure Compensation	-3 ~ +3
ISO	<ul style="list-style-type: none"> • ISO Auto • ISO 100 • ISO 200 • ISO 400 • ISO 800 • ISO 1600 • ISO 3200
ISO-A Upper Limit	3200/1600/800/400/200/100 Remarks: You cannot set ISO-A Upper Limit in ISO Auto.
Metering Modes	Average/Center/Spot
Flash Mode	Off/Auto Flash/Fill Flash
Drive Mode	<ul style="list-style-type: none"> • Single Shooting • Continuous Shooting: 3 • Continuous Shooting: 5 • Continuous Shooting: 7 • Self-timer: 2 Sec • Self-timer: 5 Sec • Self-timer: 10 Sec
Interval Timer Shooting	Off / 3 Sec / 5 Sec / 10 Sec / 30 Sec / 1 Min
Interval Mode Duration	Unlimited / 5 Min / 10 Min / 15 Min / 20 Min / 30 Min / 60 Min
OIS	On/Off
File Format	JPG / DNG+JPG

Note:

- Press the Mode button to alternate and adjust the following settings depending on your preference, including the K value and white balance in the white balance menu and modifying contrast, saturation, sharpness, image tone and hue in the filter menu.
- The resolution of File Format and Pixel Binning+HDR is fixed at 12MP (Enhance)
- The file format with HDR on is fixed at 12MP (12MP is with Pixel Binning).
Remarks: Pixel binning is used with 4 pixels binning 1 pixel.
- This increases light sensitivity and reduces noise.
- You can turn on HDR in low light environments or indoors.

Video Mode

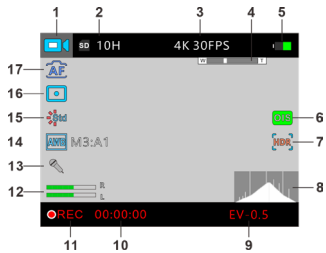

- | | |
|--|-------------------------|
| 1. Video Mode | 10. Video time |
| 2. Available Video Recording Time | 11. Video Mode On |
| 3. Video Quality /Video frame rate | 12. Audio recording bar |
| 4. Fixed focal segment Or W/T zoom bar | 13. Mic |
| 5. Battery Level | 14. White Balance |
| 6. OIS | (white balance offset) |
| 7. Pixel Binning+HDR | 15. Filter |
| 8. Histogram | 16. Metering Mode |
| 9. Exposure Compensation | 17. Focus Mode |

- Short press the power button for 2 seconds to turn on the camera and enter the main preview interface in photo mode..
- Complete the required function option settings through the settings menu and photo mode application.
- Press the camera button lightly to focus, and press the camera button again to take pictures.
- Press the "Video Button" to start recording; press the "Video Button" again to stop recording.

Video menu

To enter the video menu, press the MENU button in the photo menu from the main preview interface. Then, press the up button followed by the right button, or continuously press the right button to access the video menu directly. Use the up, down, left, and right buttons to navigate, press the OK button to confirm your selection, and use the MENU button to exit



Name	Function
Resolution	<ul style="list-style-type: none"> • 4K 30FPS • 2.7K 60FPS • 2.7K 30FPS • 1080P 120FPS • 1080P 60FPS • 1080P 30FPS • 1080P 120FPS • 720P 120FPS • 720P 60FPS • 720P 30FPS
OIS	On/Off
Pre Record	On/Off
Timestamp	Off Date Date & Time
Microphone	0 to 20
Slow Motion	<ul style="list-style-type: none"> • Off • 1080P 4X • 720P 4X
Loop Recording	Off / 1 Min / 3 Min / 5 Min
Time-Lapse Video	<ul style="list-style-type: none"> • Off • 1 Sec • 3 Sec • 5 Sec • 10 Sec • 30 Sec • 1 Min
Duration	<ul style="list-style-type: none"> • Unlimited • 5 Min • 10 Min • 15 Min • 20 Min • 30 Min • 60 Min

INFO Function Menu

Press the INFO button in the main preview interface to display the INFO main function menu. Navigate using the up, down, left, and right buttons, press the OK button to confirm your selection, and use the MENU button to exit.

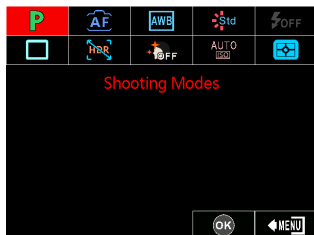

Icon	Name	Function
	Shooting Mode	Choose your shooting mode. <ul style="list-style-type: none"> • P Mode (Program) • S Mode (Shutter Priority) • SCN Mode (Scene Selection) • Standard Video Mode • Automatic Mode
	Focus Mode	Choose your focus method: <ul style="list-style-type: none"> • AF (Auto Focus) • RTAF (Real time focusing) RTAF is for focusing on fast-moving subjects
	Flash Mode	Select the desired flash mode based on lighting conditions: <ul style="list-style-type: none"> • Off • Auto Flash • Fill Flash
	HDR	On / Off

Icon	Name	Function
	White Balance	Select from the following white balance options: <ul style="list-style-type: none"> • Auto • Daylight • Cloudy • Tungsten Light • Fluorescent (High) • Fluorescent (Low) • Color Temperature (3000K-9000K)(Press mode to choose between 3000K and 9000K)
	Filter	Choose from various filter: <ul style="list-style-type: none"> • Standard • Natural • Vivid • Monotone • High Contrast B&W • Negative • High Contrast • Retro • Vintage • Warm Tone • Cold Tone • Red Tone • Green Tone • Blue Tone • Yellow Tone
	Drive Mode	Choose from the following shooting options: <ul style="list-style-type: none"> • Single Shooting • Continuous Shooting (3, 5, or 7 pictures) • Self-timer Modes (2 seconds, 5 seconds, or 10 seconds)
	Beauty	Turn on or off beauty mode for enhanced portrait photography.
	ISO	Select the appropriate ISO sensitivity: <ul style="list-style-type: none"> • ISO Auto • ISO 100 • ISO 200 • ISO 400 • ISO 800 • ISO 1600 • ISO 3200
	Metering Modes	Average/Center/Spot

System Settings Menu

To enter the system settings menu, press the MENU button in the photo menu from the main preview interface. Then, press the up button followed by three right clicks, or simply press the right button to access the system settings directly. Use the up, down, left, and right buttons to make your selection, press the OK button to confirm, and the MENU button to exit.

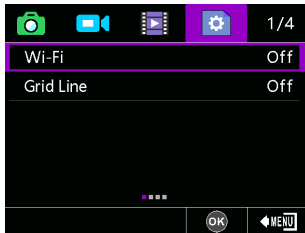

Name	Function
Wi-Fi	On/Off
Grid Line	Off White Line Yellow Line Red Line
Sounds	Shutter(On/Off) Power(On/Off) Button(On/Off) Volume(Off/Low/Standard/High)
Date & Time Settings	Year / Month / Day / Hour / Minute
Date Format	YY/MM/DD MM/DD/YY DD/MM/YY

Name	Function
Language	<ul style="list-style-type: none"> <li style="width: 33%;">• English <li style="width: 33%;">• Italian <li style="width: 33%;">• Swedish <li style="width: 33%;">• Simplified Chinese <li style="width: 33%;">• Spanish <li style="width: 33%;">• Finnish <li style="width: 33%;">• Traditional Chinese <li style="width: 33%;">• Portuguese <li style="width: 33%;">• Danish <li style="width: 33%;">• Japanese <li style="width: 33%;">• Polish <li style="width: 33%;">• Romanian <li style="width: 33%;">• Korean <li style="width: 33%;">• Arabic <li style="width: 33%;">• French <li style="width: 33%;">• Czech <li style="width: 33%;">• German <li style="width: 33%;">• Greek
Screen Brightness	Low Medium High
Screen Saver	Off 1 Min 2 Min 3 Min
Auto Power Off	Off 5 Min 10 Min
Frequency	50Hz / 60Hz
Format Card	Yes / No
Restore Factory Settings	Yes / No
Version	Displays the current software version number.

Playback/Replay Videos and Photos

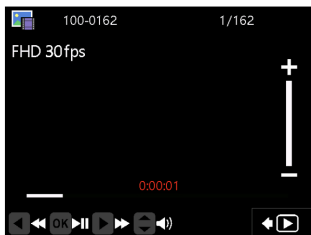

- **Power On:** Press and hold the power button for 2 seconds to turn on the camera and access the preview main interface.
- **Playback Mode:** Press the Playback button to enter playback mode.
- **Switching between photos and videos:** Use the Photo button and Video button to toggle between photos and videos. Press the INFO button to switch among video playback, photo playback, and combined playback.

Video Playback Controls:

- During video playback, press the OK button to play or pause.
- Press the left button twice to rewind (2x)
- Press the right button twice to fast forward.
- Press the up button to increase volume
- Press the down button to decrease volume
- Press the playback button to stop the video playback
- **Zoom Functionality:** Adjust to the T-end of the zoom switch to zoom in on a specific area of the photo.
- **Zoom Functionality:** Adjust the W-end to zoom out.
- **Thumbnail Mode:** Adjust the W-end to enter thumbnail mode.

Playback Menu

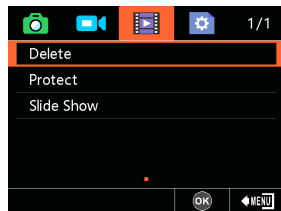

To choose the playback menu, switch to playback mode from the main preview interface and press the MENU button. Use the up, down, left, and right buttons to navigate through the options. Press the OK button to confirm your selection, and use the MENU button to exit.

Name	Function
Delete	Current All
Protect	Protect This File Unprotect This File Protect All Unprotect All
Slide show	2 Sec 5 Sec

Note:

- In standby mode, press the 'delete' button to remove the currently selected file.
- Files that are protected cannot be deleted and must be manually unprotected first.
- In the preview main interface, after entering the playback mode, press the menu button to enter the playback menu. Press up/down/left/right to select, press OK to confirm, and press the menu button to exit.

APP introduction

YASHICA App download and installation

1. Scan the QR code below directly with your phone to download and install.
App name: YASHICA



2. Download and install "YASHICA" directly by searching for it on the App Store or mobile app (Google Play) store.
- If the phone shows the following: "Do you want to allow the app to obtain usage permission during installation? Please select 'Yes' for all options."
 - While waiting for more than one minute to connect, the Wi-Fi function will automatically exit.
 - This Wi-Fi function is a limited distance point-to-point wireless connection, with a maximum distance of about 3 meters. Please use this function within the effective distance.
 - Due to different mobile phone brands and configurations, sometimes entering the main interface of the App may be slow or the camera is not connected. Please try connecting again.

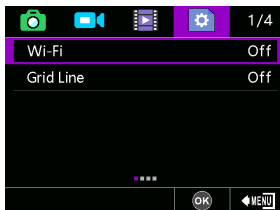

Connecting to Wi-Fi

After entering the photo menu by pressing the menu button on the preview main interface, press the up button and then right-click three times to switch to the system settings menu interface (you can also directly right-click to switch to the system settings menu interface), turn on Wi Fi, and search for the Wi Fi name on the phone: City300-XXXXXX. Enter the password 12345678, click on YASHICA to enter the APP preview interface, and start operating.



When Wi-Fi fails to connect:

- Restart the local camera and try the above connection steps again.
- Confirm whether the Wi-Fi password is entered correctly. The default Wi-Fi password for the camera is 12345678.

Troubleshooting

Error/Issue	Possible causes and solutions
The camera won't turn on.	<ul style="list-style-type: none"> • Battery Issues: Ensure the battery is installed correctly and is charged. • Operating Temperature: Use the camera within a temperature range of 0 to 40°C.
The battery drains quickly.	<ul style="list-style-type: none"> • Temperature: Battery life may diminish in low temperatures. Preheat the battery before use. • Charging: If the battery isn't fully charged, please recharge it. • Battery Life: If issues persist after recharging, the battery may be worn out and should be replaced. • Power Saving Tips: Utilize features like automatic shutdown, screen savers, and screen brightness adjustments to conserve battery power.
The camera is out of focus.	<ul style="list-style-type: none"> • Focal Length: Ensure you're shooting within the focal range. • Lighting Conditions: If the environment is too dim, manually add light. • Lens Maintenance: If the lens is dirty, clean it before taking any more photos.
Memory card issues: Unable to use memory card/unable to record or take photos.	<ul style="list-style-type: none"> • Card Damage: If the card is damaged or incompatible, consider replacing it or formatting it using the camera. • Insufficient Capacity: Check the memory card for available space. • Incorrect Format: If the card format is not supported, format it on your computer and try again.
There is an unstable Wi-Fi signal.	<ul style="list-style-type: none"> • Distance: Stay within 3 meters of the camera for optimal signal strength. • Interference: Avoid placing the camera on metal surfaces, as this can disrupt the wireless signal. • Mobile Device Signal: If your mobile phone has a weak Wi-Fi signal, consider using a different device.



Scan here for user manuals in different languages.

Specification

Product Name	YASHICA City300 Digital Camera
SKU	YAS-DGC300-WH YAS-DGC300-BK
Sensor	CMOS sensor
Aperture and focal length	F/ 1.8 f:5.68mm
Display	2.8" screen and 4:3 display
Digital Zoom	2.5X (Crop is not applicable)
Fixed lens Focal length	24mm (50MP) 35mm (24MP) 50mm (12MP) 60mm (8MP)
Focus Range	4 Focal lengths for shooting (Equivalent Full Frame)
File format	Approx. 0.15m- ∞
Video resolution	Photo: JPEG Video: MP4 4K :3840*2160 (30fps) 2.7K :2688*1512 (60fps/30fps) FHD 1080P : 1920*1080 (120fps/60fps/30fps) HD 720P : 1280*720 (120fps/60fps/30fps)
Photo resolution	50M/24M/12MP (Enhance)
Storage media	External Micro SD/TF card (supports up to 256GB, U3, Class10 or above) (Not included in the camera)
Microphone	Built-in
Speaker	Built-in
I/O interface	MIC/USB
Wi-Fi	Support
Hot Shoe	Support
Computer system compatible	Windows 7/8/10/11, Mac OSX10.5 or higher
Power input	DC5V/2A Type-C USB
Dimension (L x W x H)	106.5 x 45.4 (with lens cover 4.5) x 62.5mm
Weight	193g (with lens cover, No Battery)
Storage environment temperature	-20-60°C
Working environment temperature	0-40°C

Disclaimer

Content of harmful substances in the camera:

Component Name	Harmful substances					
	Lead (Pb)	Mercury (Hg)	Cadmium (Cd)	Hexavalent chromium (Cr(VI))	Polybrominated biphenyls (PBB)	Polybrominated diphenyl ethers (PBDE)
Host shell and components	X	O	O	O	O	O
Internal electronic components of the host	X	O	O	O	O	O
Charger casing and components	O	O	O	O	O	O
Internal electronic components of charger	O	O	O	O	O	O

This table has been created in accordance with SJ/T 11364 provisions.

- O: The concentration of hazardous substances in all homogeneous materials of the component is below the limits set by GB/T 26572.
- X: The concentration of hazardous substances in at least one homogeneous material of the component exceeds the limits specified in GB/T 26572, and no viable alternative solution currently exists in the industry. This product meets the requirements of the EU RoHS environmental directive.

Warranty Policy

If you are experiencing a problem with a YASHICA purchase, please kindly read the information below to understand and determine if the issue is covered under YASHICA warranty.

1. YASHICA products are guaranteed against manufacturing defects one (1) year from the original date of purchase. YASHICA's sole obligation in the event of defects during the said period is to repair or replace the defective part or product with a comparable part at YASHICA's discretion. Please keep the receipt or invoice of your purchase.
2. The warranty card and original purchase receipt must be emailed to YASHICA at cs@yashica.com and/or present to the YASHICA authorized service facility before any repairs can be made under warranty.
3. All costs, including but not limited to transportation, mail and incidental charges, in relation to repair work are at user's expenses.
4. Warranty does not apply to any of the followings:
 - Damages arising from normal wear and tear; cosmetic damages including scratches or dents;
 - Damages caused by misuse, abuse, mishandling, misplacement, or alteration of the product or any usages that contradict with the instructions stated in the User Manual;
 - Products that have been disassembled, repaired or modified by person(s) other than YASHICA authorized service facility;
 - Losses and damages arising from accidents or natural calamities;
 - Damage caused as a result of improper transportation or packing/package when returning the product
5. If it is determined that the product is not covered under warranty, you will be required to confirm the quotation provided and pay for the repair. Once the payment is made, YASHICA will arrange for relevant repair/replacement.
6. If it is determined that the warranty covers the product's fault, such as manufacturing defect covered by the warranty, YASHICA will repair/replace your unit at no charge/free of charge. At YASHICA's discretion, YASHICA will cover shipping costs. Communication will be carried out via email at cs@yashica.com
7. We reserve the right to modify these terms without prior notice.

For any enquiries, please feel free to email to cs@yashica.com
Address: Room 403, Floor 4, Shiu Fat Industrial Building, 139-141 Wai Yip Street, Kwun Tong, Kowloon, Hong Kong

YASHICA products are guaranteed against manufacturing defects one (1) year from the original date of purchase. YASHICA's sole obligation in the event of defects during the said period is to repair or replace the defective part or product with a comparable part at YASHICA's discretion. Damage resulting from use, accident, or normal wear and tear is not covered by this or any warranty. YASHICA assumes no liability for any accident, injury, death, loss, or other claim related to or resulting from using this product. In no event YASHICA is liable for incidental or consequential damages relating to or resulting from using YASHICA products or any of their parts. Returns or replacement of parts and products may be subjected to shipping, handling, replacement and restocking fees.

If you have further questions or comments, please contact our customer support team - at cs@yashica.com.

YASHICA.com