

MARBL.

User Manual & Installation Guide For Orbit Models



**SCAN ME TO VIEW
INSTALLATION VIDEO GUIDE**



Table of Contents

1.	SAFETY TIPS	5
2.	TOOLS AND MATERIALS REQUIRED.....	5
3.	UNPACKING THE MARBL ORBIT	6
4.	ORBIT KITS AND PARTS INVENTORY.....	7
5.	INSTALLATION PREPARATION.....	12
5.1.	MARBL ORBIT FIRMWARE UPDATE	12
5.2.	SELECTING ORBIT CONFIGURATION AND INSTALLATION LOCATION	12
5.2.1.	NORMAL CONFIGURATION.....	14
5.2.2.	LONG ARM CONFIGURATION.....	15
5.2.3.	SUPER ARM CONFIGURATION.....	16
5.3.	INSTALLING THE CEILING PLATE	17
6.	MOUNTING ORBIT MOTOR TO CEILING PLATE OR TELESCOPING DOWN ROD.....	18
6.1.	ORBIT ASSEMBLY	18
6.2.	MOUNT ORBIT MOTOR DIRECTLY TO CEILING PLATE	19
6.3.	HIGH CEILING INSTALLATION – TELESCOPING DOWN ROD TO CEILING PLATE	20
6.4.	INSTALLING THE DUAL ARM RECEIVER	21
6.5.	ATTACHING ARM POLES TO DUAL ARM RECEIVER (NORMAL ARM CONFIGURATION)	22
7.	INSTALLING THE LED LIGHT KIT (STUDIO AND PRO KIT VERSIONS).....	23
8.	MOUNTING AND LEVELING CAMERA TO ORBIT.....	24
8.1.	MOON FOCUS BALL AND LEVELING CAMERA	24
8.2.	MOUNTING THE CAMERA	24
8.3.	COUNTERWEIGHTS	26
8.4.	COMPOSING THE SHOT	27
8.4.1.	MAIN SUBJECT – CENTER OF FOCUS.....	27
8.4.2.	MULTIPLE SUBJECTS (I.E., MAIN SUBJECT AND SECONDARY SUBJECT)	27
9.	INSTALLING ADDITIONAL MOUNTS AND ACCESSORIES	28
9.1.	DOUBLE BALL HEAD MOUNTING	28
9.2.	SECONDARY CAMERA MOUNT (I.E., IPHONE OR ANDROID SMARTPHONE).....	28
9.3.	V-MOUNT BAR CLAMP AND QUICK RELEASE	29
10.	OPERATING YOUR ORBIT AND LIGHT RING	30
10.1.	LED LIGHT RING (INCLUDED WITH STUDIO AND PRO KITS)	30
10.2.	ADDITIONAL LIGHT RING SPECIFICATIONS:.....	31
11.	REMOTE CONTROL	32
11.1.	REMOTE CONTROL OPERATION AND GUIDE	33
12.	OUTDOOR ASSEMBLY (ORBIT PRO KIT)	37
12.1.	OUTDOOR BRACKET ASSEMBLY.....	37
12.2.	TRUSS ASSEMBLY	39
13.	MARBL APP.....	40
14.	TROUBLESHOOTING AND MARBL SUPPORT	45
14.1.	TROUBLESHOOTING	45

14.2.	MARBL SUPPORT	46
14.3.	CARE OF YOUR ORBIT	47
15.	REPLACEMENT PARTS.....	47
15.1.	MARBL ORBIT ACCESSORIES	47
16.	WARRANTY.....	48
16.1.	PART A – LIMITED WARRANTY	48
16.2.	PART B – WARRANTY PERIOD OF PARTS	50
16.3.	PART C – COUNTRY/REGION SPECIFIC TERMS	51

List of Figures

Figure 1: ORBIT packaging	6
Figure 2: Measure Space Requirements	12
Figure 3: Ceiling Plate Template	13
Figure 4: Normal Configuration	14
Figure 5: Long Arm Configuration	15
Figure 6: Super Arm Configuration	16
Figure 7: Ceiling Plate Installation.....	17
Figure 8: Ceiling Plate Installation.....	18
Figure 9: ORBIT Motor attached to Ceiling Plate	19
Figure 10: Assembly of Telescoping Down Rod	20
Figure 11: Installation of Down Rod Collar to Telescoping Down Rod and Mounting of ORBIT to Down Rod	20
Figure 12: Dual Arm Receiver attached to ORBIT Motor	21
Figure 13: Removing threaded endcap from arm pole.	22
Figure 14: Arm Joint with T-handle and screws and ¼"-20 Threaded Loop with flat edge flush to Arm Joint.	22
Figure 15: Plastic holder mount for Allen wrenches.....	23
Figure 16: Aluminum bolts, magnetic bubble level and moon ball	23
Figure 17: Ratchet strap installation and use	24
Figure 18: Bar sleeve with ¼"-20 mount (single knob)	25
Figure 19: Dual collar sleeve with ¼"-20 mount (dual knobs)	25
Figure 20: Counterweights.....	26
Figure 21: Double Ball Head.....	28
Figure 22: Smart Phone Camera Mount	28
Figure 23: V-Mount Bar Clamp and Quick Release	29
Figure 24: Light Ring Button and equipment descriptions	30
Figure 25: Light Ring top and bottom features	31
Figure 26: Remote Control Button Guide	33
Figure 27: Outdoor installation example	37
Figure 28: Attaching Baby pin to Speed Rail adapters	37
Figure 29: ORBIT mounted directly to speed rail adapter	38
Figure 30: Attaching Ceiling Plate and Telescoping Down Rod to Speed Rail adapter	38
Figure 31: Outdoor Bracket	39
Figure 32: Truss section	39
Figure 33: MARBL APP Button Diagram	41
Figure 34: MARBL APP Time Lapse Mode	43
Figure 35: MARBL APP Stop Motion Mode	44

List of Tables

Table 1: Battery Life and MAX RPM	34
Table 2: Visor Colors/Modes.....	34
Table 3: Warranty Period of Parts.....	50

List of Abbreviations

ABBREVIATION	DEFINITION
CR	Color rendition
CRI	Color Rendering Index
HRS	Hours
IR	Infrared (sensor)
LED	Light-emitting diode
mAh	milliampere/hour
MINS	Minutes
OD	Outside diameter
RPH	Rotations per hour
RPM	Revolutions per minute
RTNS	Rotations
TCLI	Television Lighting Consistency Index
TM-30	ANSI/IES TM-30-20 is a voluntary standard document describing the IES recommended method for evaluating light source color rendition
UNC	Unified Fine Threads
VFX	Visual Effects

1. Safety Tips

⚠ IMPORTANT: READ ALL INSTRUCTIONS AND SAFETY INFORMATION CAREFULLY BEFORE INSTALLING YOUR ORBIT AND SAVE THESE INSTRUCTIONS. ⚠

- Select a location for the **ORBIT** that allows clear space for the Arm Poles to rotate and avoid obstruction.
- Use a stud finder to identify a sturdy ceiling joist if using the Ceiling Plate to mount the **ORBIT**.
- After installation is complete, check that all connections are secure, and all Allen screws and knobs are tightened.
- Do not walk into or insert objects in the **ORBIT's** motion path while operating.
- Always stop the **ORBIT** motor prior to making any adjustments to the **ORBIT** or your camera.

⚠ WARNING: TO REDUCE THE RISK OF PERSONAL INJURY, USE ONLY PARTS PROVIDED WITH THIS ORBIT. THE USE OF PARTS OTHER THAN THOSE PROVIDED OR APPROVED BY MARBL LLC WITH THIS ORBIT WILL VOID THE WARRANTY.

NOTE: The important safety precautions and instructions appearing in the manual are not meant to cover all possible conditions and situations that may occur. It must be understood that common sense and caution are necessary factors in the installation and operation of this **ORBIT**.

2. Tools and Materials Required

Below is a list of tools and materials required to install the **ORBIT**. Please use proper care and abide by all safety precautions according to any and all manufacturer's instructions and warnings. MARBL LLC is not responsible for any tools or materials not provided directly by MARBL LLC.

- Ladder, height dependent upon installation site (not included)
- Stud Finder (not included)
- Power Drill with drill bits (not included)
- Dual 17mm / 19mm wrench (included)
- Allen wrenches, various sizes (included)
- USB-C cable (not included)
- Tape measure (not included)
- Sandbags for additional counterweights (not included)

3. Unpacking the MARBL ORBIT

Carefully open the packaging. If using a sharp knife, exercise care to avoid cutting too deeply into packing materials.

- Remove **ORBIT motor** (Part #9) and begin charging it with the **12V Power Cable** (Part #11).
- Remove items from Styrofoam inserts only when ready to install.
- Remove motor housing and place on carpet or Styrofoam to avoid damage to finish.
- **DO NOT** discard carton or Styrofoam inserts in case the **ORBIT** needs to be returned for repairs.
- Check against parts inventory that all parts have been included. Contact [MARBL Support](#) team if anything is missing or broken.
- PRO Kits comes packed in carrying case.




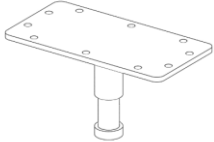

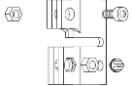




Note: Take a picture of how it's packaged in case you need to package for travel and/or shipping for support.

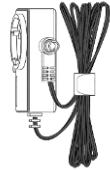

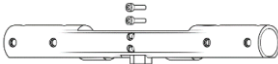


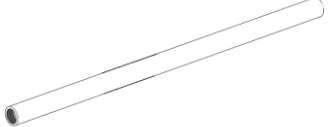

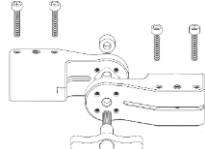


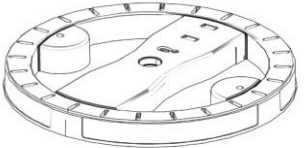


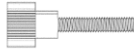
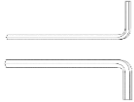





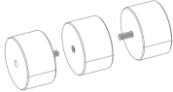




Figure 1: ORBIT packaging

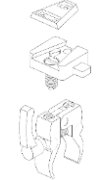
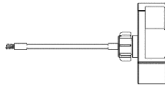

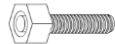
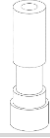

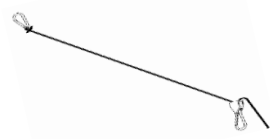



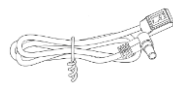

4. ORBIT Kits and Parts Inventory

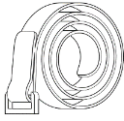


All kits include mounting hardware for installation of the **Ceiling Plate**. PRO Kits include extra outdoor brackets that will require you to purchase stands and speed rails separately.

NO	STEP	PART NAME	PART FIGURE	QUANTITY		
				Base Kit	Studio Kit	PRO Kit
01	Tool	17mm/19mm wrench		1	1	1
02	Tool	Allen wrenches (set includes two, different sizes)		1	1	1
03	Ceiling	Ceiling (Concrete) Steel Hex Head Sleeve Anchor 2"		6	6	6
04	Ceiling	Ceiling Plate		1	1	1
05	Ceiling	Ceiling Wood Screws 2 1/4"		6	6	6
06	Ceiling	Down Rod Collar with knob and screws		1	1	1
07	Ceiling	Telescoping Down Rod (Adjustable 27"-46") - Outer rod with knob is 25"		1	1	1
08	Ceiling	Telescoping Down Rod (Adjustable 27"-46") - inner rod is 21.125"		1	1	1
09	Motor	ORBIT Axibo Powered Stealth Motor		1	1	1
10	Motor	Spring Clip and Lock nut set (attached to motor)		1	1	1

NO	STEP	PART NAME	PART FIGURE	QUANTITY		
				Base Kit	Studio Kit	PRO Kit
11	Power	12V Power Cable		1	1	1
12	Power	USA, Type C and Type G international power adapter set		1	1	1
13	Arms	Dual Arm Receiver		1	1	1
14	Arms	Dual Arm Receiver aluminum knobs (MARBL logo) (attached)		4	4	4
15	Arms	Dual Arm Receiver set screws (attached)		2	2	2
16	Arms	24" anodized black aluminum Arm Poles		2	2	2
17	Arms	16" anodized black aluminum Arm Poles		2	2	2
18	Arms	Arm Joints with attached screws and T-handle knob		2	2	2
19	Arms	Threaded End Caps with 1/4"-20 mount		2	2	2
20	Arms	1/4"-20 threaded loops for use with Ratchet straps <i>Note: Two have curved bottom to install around Telescoping Arm</i>		4	4	4
21	Light Ring	Light Ring		N/A	1	1

NO	STEP	PART NAME	PART FIGURE	QUANTITY		
				Base Kit	Studio Kit	PRO Kit
22	Light Ring	Light ring aluminum knob		N/A	2	2
23	Light Ring	Allen wrenches for Light Ring (set includes two, different sizes)		N/A	1	1
24	Light Ring	Plastic holder mount for Allen wrench		N/A	2	2
25	Light Ring	Magnetic focus grey moon ball		N/A	1	1
26	Light Ring	Magnetic Bubble Level (blue)		N/A	1	1
27	Light Ring	Aluminum IR Remote Control		1	1	1
28	Light Ring	CR2032 battery for remote control		1	1	1
29	Arm Acc	1-lb counterweights		3	3	6
30	Arm Acc	Bar sleeve with 1/4"-20 mount (single knob)		1	1	1
31	Arm Acc	Dual Collar sleeve with 1/4"-20 mount (dual knobs)		-	-	1
32	Arm Acc	Single Ball head with cold shoe quick release		1	1	1
33	Arm Acc	Dual ball head to 1/4"-20 mount with replacement washers		-	-	1

NO	STEP	PART NAME	PART FIGURE	QUANTITY		
				Base Kit	Studio Kit	PRO Kit
34	Arm Acc	V-mount Bar clamp and quick release		-	-	1
35	Arm Acc	Smartphone camera mount ¼"-20 thread		1	1	1
36	Other Acc	¼"-20 cold shoe adapter (for cameras without cold shoe)		1	1	1
37	Other Acc	2 ½" bolt with washer		-	-	1
38	Other Acc	Baby pin (for connecting ORBIT rail supports to stands)		-	-	2
39	Other Acc	Outdoor brackets		-	-	3
40	Other Acc	Ratchet straps		2	2	4
41	Other Acc	Ceiling eyelets (for ratchet straps)		2	2	4
42	Other Acc	Drywall anchors for ceiling eyelet screws		4	4	8
43	Other Acc	Drywall screws for ceiling eyelet		4	4	8
44	Other Acc	D-tap to 12V cable (26 in.)		-	-	1
45	Other Acc	D-tap to D-tap Extension cable (10 ft)		-	-	1

NO	STEP	PART NAME	PART FIGURE	QUANTITY		
				Base Kit	Studio Kit	PRO Kit
45	Other Acc	24" Velcro lens straps		2	2	2
46	Case	MARBL ORBIT PRO Bag with shoulder strap* (Strap stored in front pouch during shipment)		-	-	1
47	Case	Light Ring Case (with foam insert for power buttons)		-	-	1

*Remove prior to shipping and/or travel to prevent loss or damage.

5. Installation Preparation

To ensure fastest set up, verify that you have all tools handy and follow the steps below in exact order. Ensure the **ORBIT** is fully charged and have a USB-C cable and computer available.

5.1. MARBL ORBIT Firmware Update

Prior to installing the **ORBIT** to the ceiling, update to the latest firmware. Ensure the **ORBIT** is fully charged before updating the firmware and proceeding with further installation of the **ORBIT**.

Firmware will require the following:

- MAC or PC
- USB-C cable
- Chrome-based browser (Chrome, Microsoft Edge, or Opera)

Follow the steps provided in the [Firmware updater instructions](#) and bookmark the weblink to check/install future updates.

*Note: After updating the firmware, if you encounter feedback, or jerking movements, check that the **ORBIT** is fully charged, try the firmware update again and if still no improvements, contact [MARBL Support](#) team for further assistance. A ticking noise is normal operating noise indicating Wi-Fi activity.*

5.2. Selecting ORBIT Configuration and Installation Location

⚠ IMPORTANT: CEILING PLATE MUST BE MOUNTED WITH AT LEAST TWO SCREWS FASTENED TO CEILING JOISTS/STUDS TO ENSURE SAFE AND PROPER INSTALLATION. DO NOT MOUNT INTO DRYWALL ONLY. ⚠

The **ORBIT** can be configured several different ways to extend arm lengths. Review the different configurations ([Normal Configuration](#), [Long Arm Configuration](#), [Super Arm Configuration](#)) prior to setting up the **ORBIT**. Make sure to evaluate your installation location thoroughly to ensure that Orbit's arms will have enough room to avoid obstructions in the rotational path while in operation as shown in the example in [Figure 2](#).

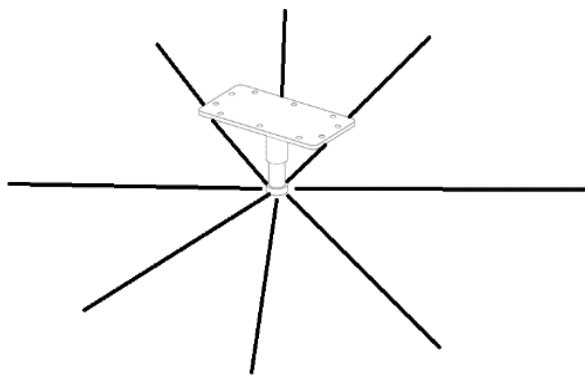


Figure 2: Measure Space Requirements

Note: If you change the arm configuration at any time, ensure that you always have the necessary space requirements on all sides to avoid obstructions in the motion path.

Follow the steps below to measure before you drill.

1. Use a stud finder to locate a ceiling joist in the area that you have selected to place your **ORBIT**. Hold the **Ceiling Plate** (Part #4) on that area and mark two opposing holes that match the plate holes in line with the ceiling joist marking. We recommend two that are in the middle of the long sides of the plate as shown in [Figure 3](#). Mark an “X” where the pin should be located. From this center point (location of pin coming out of the plate), measure the space requirement distances from your chosen Arm Configuration (Normal = 50 in/127cm, Long Arm = 80in/203cm, and Super Arm = 53 in/135cm,)

⚠ IMPORTANT: DO NOT DRILL OR FASTEN ANYTHING YET.

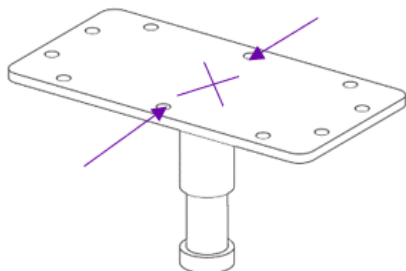


Figure 3: Ceiling Plate Template

2. Using a tape measure, ensure that the **Ceiling Plate** location meets the recommended space requirements described in the arm configuration diagrams from sections [5.2.1](#), [5.2.2](#), and [5.2.3](#).
3. Keep in mind that **ORBIT** has articulating **arm joints** (Part #18) and a **Telescoping Down Rod** (Part #7 and #8) that can be utilized to bring the camera closer to the ground. This also means that obstacles below the **ORBIT** (i.e., walls, shelving, or other wall-mounted items, and/or furniture) may be in the path of orbiting arms and camera equipment when **ORBIT** is lowered on the **Telescoping Down Rod** or angled inward. Plan your install knowing that you may need orbiting room below the **ORBIT** to capture certain angles with your camera.

5.2.1. Normal Configuration

The Normal configuration with both arms, spans on one side to equal 120cm or 47.24 inches.

This configuration includes one **16" Arm Pole**, one **24" Arm Pole** and one **Arm Joint** on each side of the **Dual Arm Receiver**.

Space Requirement: 50 Inches minimum from the **Ceiling Plate** pin outward in all directions

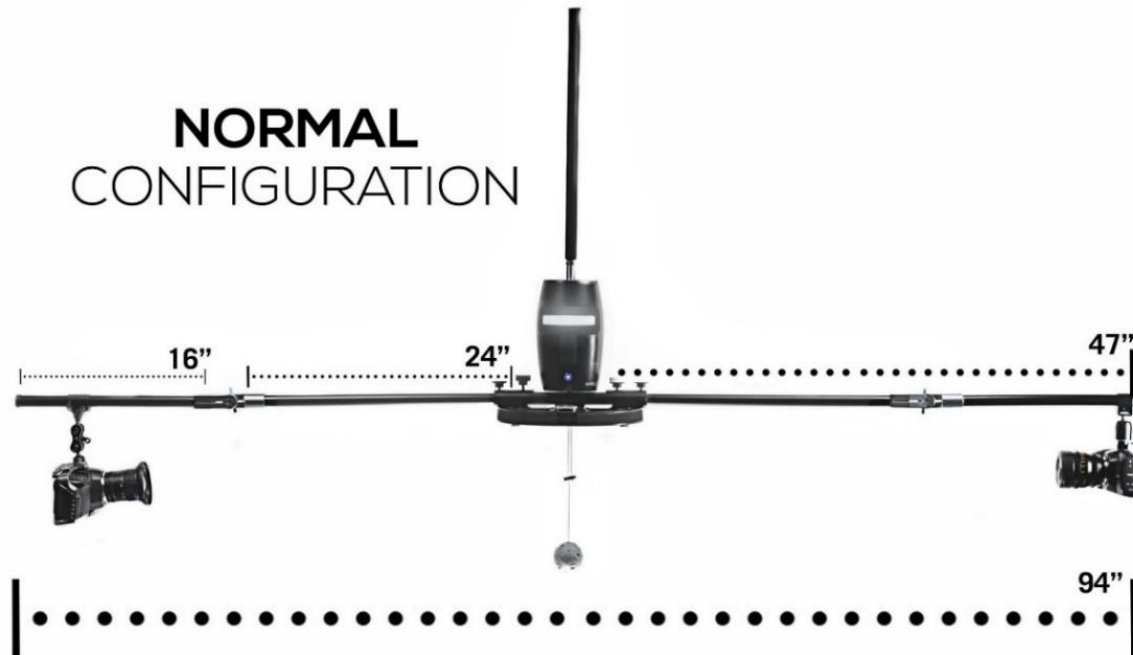


Figure 4: Normal Configuration

5.2.2. Long Arm Configuration

The Long Arm span stacks longer poles on one side for more length with span on longest side at 140cm or 55.11 inches.

This configuration includes two **24" Arm Poles** and one **Arm Joint** on one side of the **Dual Arm Receiver** with two **16" Arm Poles** and one **Arm Joint** on the opposing side.

Space Requirement: 53 Inches minimum from the **Ceiling Plate** pin outward in all directions

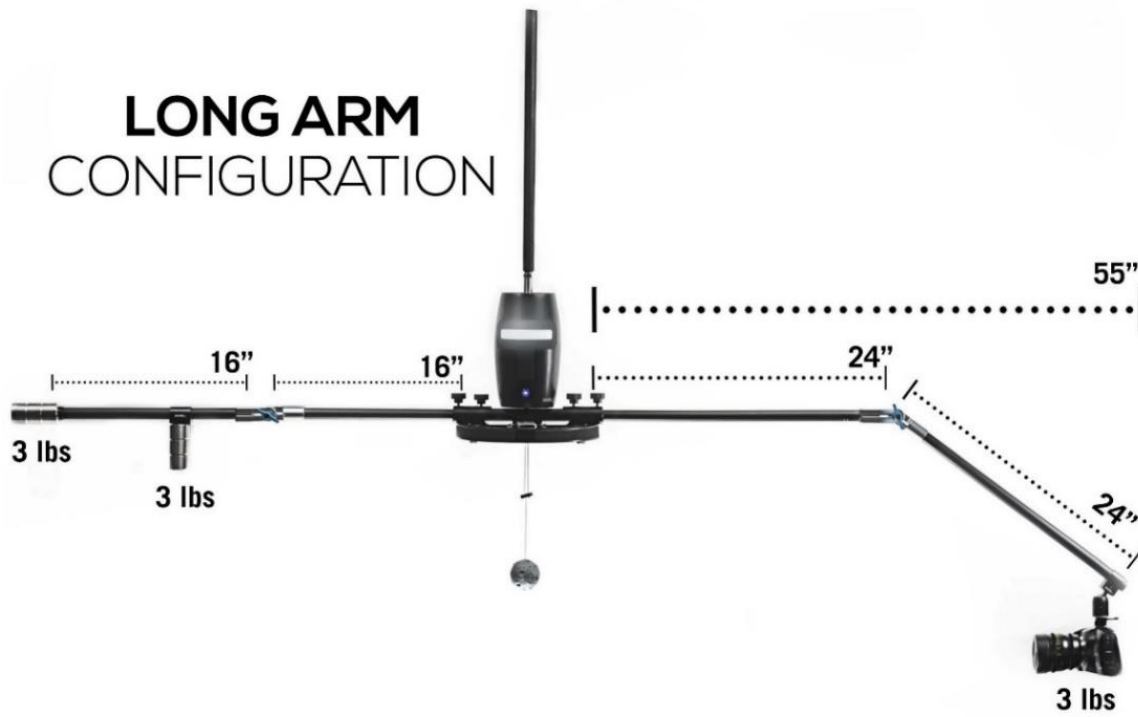


Figure 5: Long Arm Configuration

5.2.3. Super Arm Configuration

The longest arm span possible, aka the “Super Arm” Configuration, by removing both the **Arm Joint** and the longest pole and stacking them on one side the arm span maximizes to 183cm or 72.04 inches. This arrangement is great for longer focal lengths to exaggerate the optical qualities (bokeh, magnification, speed, light leaks).

This configuration includes one **16” Arm Pole**, two **24” Arm Poles** and two **Arm Joints** on one side of the **Dual Arm Receiver** with the remaining **16” Arm Pole** on the opposing side. This will require a sandbag (not included) for counterweight as shown in example below.

Space Requirement: 80 Inches minimum from the **Ceiling Plate** pin outward in all directions



*Sandbag not included in any kits

Figure 6: Super Arm Configuration

5.3. Installing the Ceiling Plate

The **Ceiling Plate** has ten (10) holes but only two (2) holes are directly across from each other as shown in [Figure 7](#). It is recommended to use at least the two holes marked in [Figure 7](#) that are in a straight line for standard wood joist installation.

1. Use a drill with 7/32-inch drill bit to create pilot holes in your ceiling joist. Fasten the **Ceiling Plate** (Part #4) to the ceiling using a drill or a Phillips head screwdriver and the included **Ceiling Wood Screws** (Part #5).
2. Next test that the **Ceiling Plate** is securely fastened by gently tugging down on it. If more support is needed, then install the supplied drywall anchors and extra screws using a ¼ inch drill bit. Fasten down the **Ceiling Plate** with additional screws as needed.

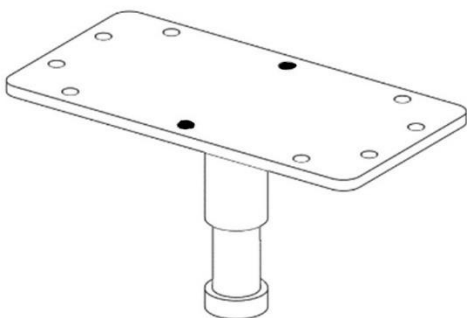


Figure 7: Ceiling Plate Installation

3. Proceed to [Mounting ORBIT Motor to Ceiling Plate or Telescoping Down Rod](#) steps.

⚠ WARNING: DO NOT MOUNT THE CEILING PLATE INTO DRYWALL ONLY. THE CEILING PLATE MUST HAVE AT LEAST TWO SCREWS FASTENED INTO A JOIST/STUD.

****Note: It is very important that you use the proper hardware when installing the ceiling bracket as this will support the ORBIT and any attached camera gear.***

6. Mounting ORBIT Motor to Ceiling Plate or Telescoping Down Rod

The **ORBIT** can be mounted directly to the **Ceiling Plate** (Part #4) or fastened to the **Telescoping Down Rod** (Part #7 and #8) making it ideal for higher ceilings or table height shots.

Review the assembly options below and choose your installation preference prior to mounting the **ORBIT motor** (Part #9).

6.1. ORBIT Assembly

⚠ IMPORTANT: The first time installing the **ORBIT motor**, you will need to remove the **compression spring clip and lock nut** (Part #10) from the **ORBIT** and then screw on the **lock Nut** with the **compression spring** on top of the **lock nut**.

Note: Save the second Nut for installation of the Dual Arm Receiver.

⚠ WARNING: ALWAYS ENSURE THAT THE SPRING CLIP AND LOCK WASHER HAVE BEEN SECURELY FASTENED TO THE DOWN ROD BEFORE POWERING ON THE MOTOR.

1. Attach the **ORBIT** directly to the **Ceiling Plate** or to the **Telescoping Down Rod** depending on your ceiling height with the **MARBL logo** facing right-side up.
2. Next screw the **nut** back onto the **ORBIT** and then place the **spring clip** back onto the motor shaft so that it now sits above the **lock nut** (see [Figure 8](#)).

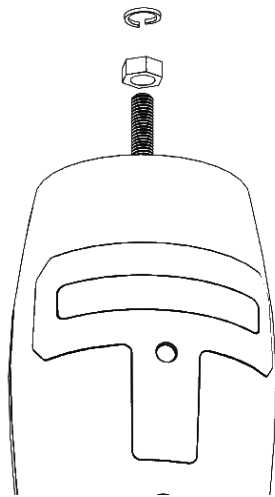


Figure 8: Ceiling Plate Installation

6.2. Mount ORBIT Motor Directly to Ceiling Plate

The **ORBIT** can be mounted directly to the plate for low ceiling locations.

1. Hand screw the **ORBIT** to the **Ceiling Plate** clockwise until hand tightened to the **Ceiling Plate**.
2. Tighten the nut with the included **19mm wrench** (Part #1) to compress the **spring clip** between the **Nut** and the pin mounted to the **Ceiling Plate** as shown in [Figure 9](#) below. This is to prevent the **ORBIT** from falling off when reversing directions.



Figure 9: ORBIT Motor attached to Ceiling Plate

3. Skip to [Installing the Dual Arm Receiver](#).

6.3. High Ceiling Installation – Telescoping Down Rod to Ceiling Plate

Note: PRO kits Down Rods come pre-assembled, but the BASE and STUDIO kits require assembly.

1. Attach the **Down Rod Collar** (Part #6) to the bottom of the **25" Outer Telescoping Down Rod** (Part #7). (Hint: The bottom is the side without the knob) Lightly tighten allen bolt on the **Down Rod Collar** with the included **Allen wrenches** (Part #2). *Note: Do not over-tighten the Allen bolt, as it can strip the bolt threading.*
2. Loosen the **knurled knob** on the top of the **Telescoping Down Rod** (Part #7) and insert the narrow end of inner **21.125" Telescoping Down Rod** (Part #8) into the **25" Telescoping Down Rod** (Part #7). The inner **Down Rod** (Part #8) should slide all the way to the bottom of the **Telescoping Down Rod** (Part 8) and **Down Rod Collar** with the knob and screws (Part #6). If it doesn't slide through then loosen the allen bolts on the collar until it does. Then lightly tighten the nut on the **Down Rod Collar** (Part #7). It should look like [Figure 10](#) below.

When collapsed, this lowers the **ORBIT motor** 27 inches from the base plate. When fully expanded, it lowers 42 inches.

3. Collapse or extend to the desired length and tighten the screw on the **Down Rod Collar** and mount the **Telescoping Down Rod** to the **Ceiling Plate** until it is flush and tighten with the included twist knob. Ensure that the knob screw is above the notch on the baby pin coming out of the **Ceiling Plate**. Then give a light tug on the downrod assembly to ensure that you have fully fastened it. See [Figure 11](#) below.

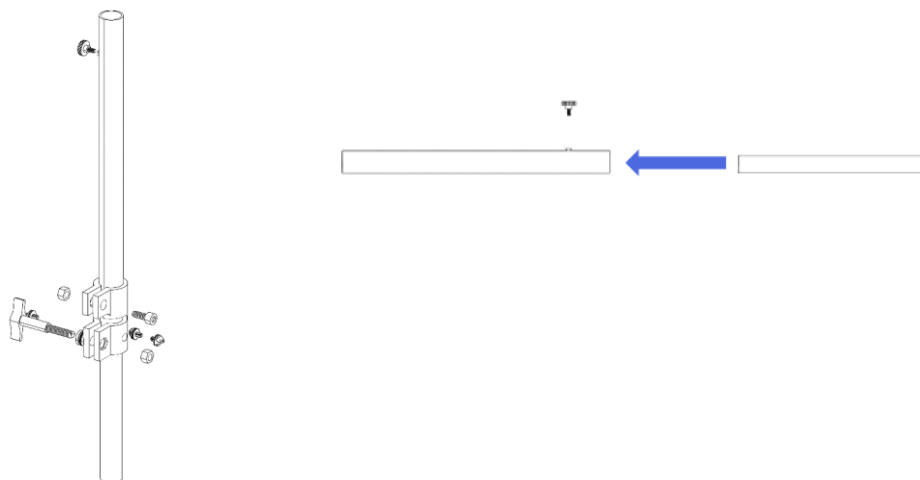


Figure 10: Assembly of Telescoping Down Rod

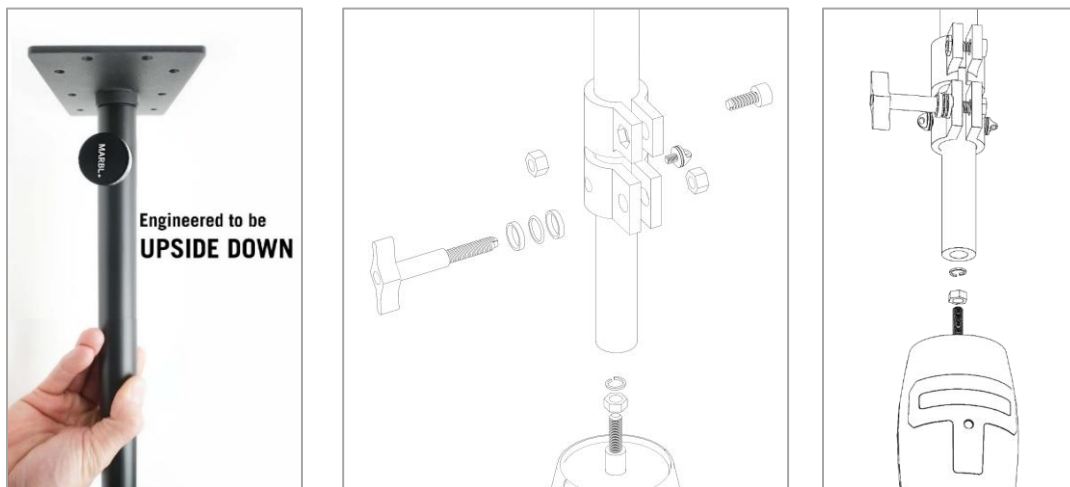


Figure 11: Installation of Down Rod Collar to Telescoping Down Rod and Mounting of ORBIT to Down Rod

6.4. Installing the Dual Arm Receiver

1. Unscrew the nut on the bottom of the **ORBIT motor** and keep within reach for subsequent step. Loosen the two **set screws** (Part #15) on the **Dual Arm Receiver** (Part #15), slide the **Dual Arm Receiver** onto the threaded motor mount. Verify that the **set screws** align with the slot on the end of the Motor bolt.

The **Dual Arm Receiver** (Part #13) should be mounted so that the **Dual Arm Receiver aluminum knobs** (Part #14) are oriented on top as shown in [Figure 12](#) below.

2. Screw on the **nut** (saved from motor in previous step from Section 6.1) securing the **Dual Arm Receiver** to the **ORBIT** motor shown in [Figure 12](#) below. Then, hand tighten the **washer**.
3. Tighten the **set screws** so that they seat tightly into the groove on the motor mount bolt using the included **Allen wrenches**. Finally tighten the **Nut** snugly onto the **Dual Arm Receiver** with the included **19mm wrench** until all are securely tightened.

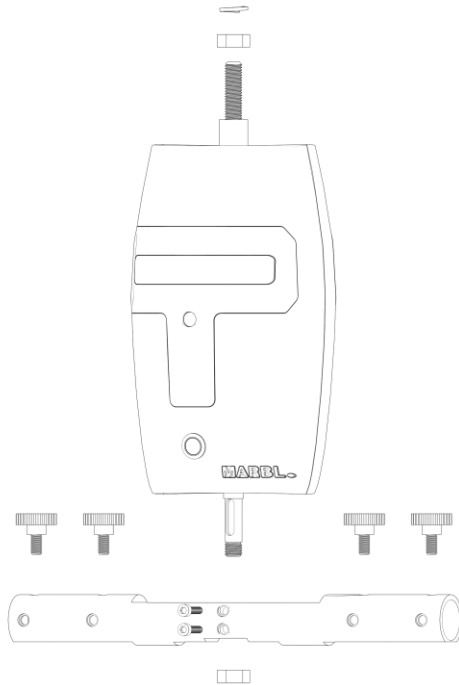


Figure 12: Dual Arm Receiver attached to ORBIT Motor

*PRO TIP: Check the level that is built into the side of the **Dual Arm Receiver**. If it is not level, check if adjustments need to be made to the **Ceiling Plate** such as placing shims under the **Ceiling Plate**. Those with vaulted ceilings may need a ball joint attachment (not included) to level the **ORBIT**.*

6.5. Attaching Arm Poles to Dual Arm Receiver (Normal Arm Configuration)

1. Locate the **24" Arm Poles** and unscrew the **threaded end caps** (Part #19) as shown in [Figure 13](#). Set aside the **threaded end caps** aside for a later step. Loosen the **Dual Arm Receiver aluminum knobs** (with MARBL logo) on the **Dual Arm Receiver** to install the **24" Arm Poles** on both ends of the **Dual Arm Receiver**.



Figure 13: Removing threaded endcap from arm pole.

2. Gently loosen the allen bolts on the **Arm Joints** (Part #18) and slide the Kondor Blue **Arm Joint** onto the end of the **24" Arm Pole**. Look through the open slit on the **Arm Joint** to ensure that the arm is inserted past both Allen screws. Attach the non-threaded end of one **16" black Arm Pole** to the other end of the Kondor Blue **Arm Joint**. Tighten using only the method in the next step.
3. **DO NOT** tighten or loosen allen screws individually or you may strip the screws. **Alternate** tightening of each allen screw evenly on either side of the joint until tightened.
4. Keep the **Arm Joints** so that they are perpendicular to the **Dual Arm Receiver** with the T-handle knob on the side enabling **Arm Poles** to articulate up and down. Tighten the T-handle knobs once the **Arm Poles** are installed to the desired lengths and position heights for each end.
5. Screw the $\frac{1}{4}$ "-20 **threaded loops** (Part #20) in the threaded $\frac{1}{4}$ 20" hole on the top of the **arm joint**. (See [Figure 14](#))

Note: The arrangement of arm poles varies depending on which arm configuration you want to use. Refer to sections [Long Arm Configuration](#), or [Super Arm Configuration](#) and adjust arms according to the image in those sections.



Figure 14: Arm Joint with T-handle and screws and $\frac{1}{4}$ "-20 Threaded Loop with flat edge flush to Arm Joint.

7. Installing the LED Light Kit (Studio and PRO Kit versions)

⚠ IMPORTANT: *PRO Kits are packaged with a Light Ring in a carrying case. A foam protector is installed around the Light Ring power button to prevent the light from turning on during transport. DO NOT THROW THIS FOAM AWAY. You will need to re-apply it over the power button prior to inserting the Light Ring back into its case for travel.*

1. Attach the included **plastic holder mount for Allen wrenches** (Part #24) to the **Light Ring** (Part #21), noting the different size mounts to match with **Allen wrench** tool size. Store the included **Allen Wrenches** by sliding (not pressing) the wrenches in the clips for easy access and adjustments to the **ORBIT**. The (magnetized) **ORBIT** Remote Control can be stored on the opposite side of the **Allen wrenches** on the **Light Ring**.

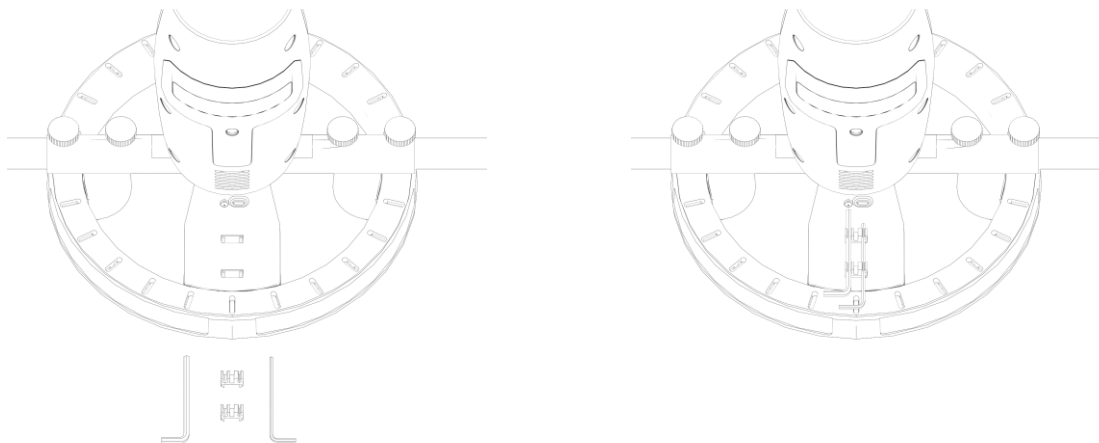


Figure 15: Plastic holder mount for Allen wrenches

2. Mount the **Light Ring** (with the yellow safety sticker pointing towards the ground) to the **Dual Arm Receiver**. Tighten with the included **Light Ring aluminum knobs** (Part #22).

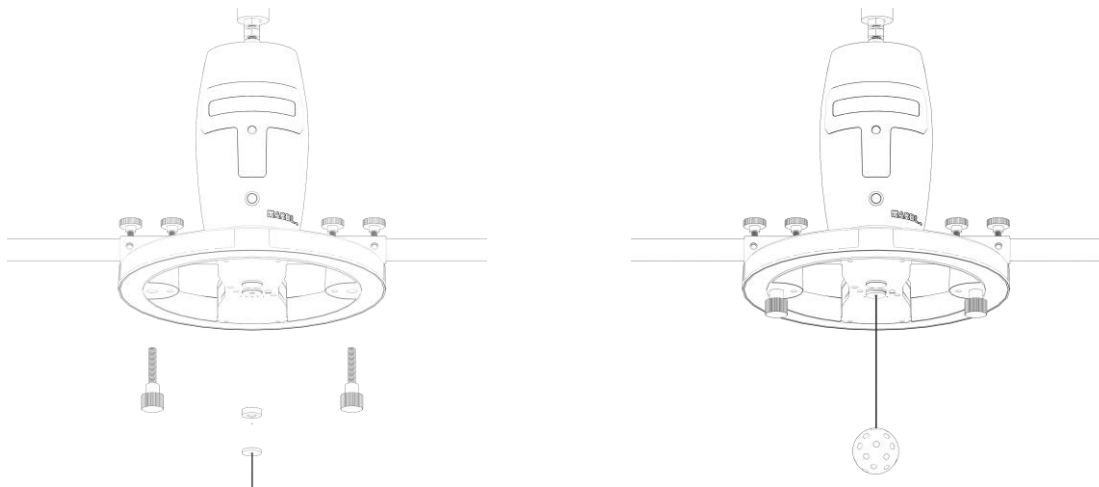


Figure 16: Aluminum bolts, magnetic bubble level and moon ball

3. Attach the blue **magnetic bubble level** (Part #26) to the middle of the **Light Ring** to verify that everything is in balance. Attach the **Magnetic Focus Moon Ball** with string (Part #25) to establish center for your subject. The string can be adjusted to level with camera.

*PRO TIP: The **Light Ring** can be charged with the included **20ft Power Cable** or with a **USB-C cable**. The **20ft Power Cable** can be used to charge either the **ORBIT motor** or **Light Ring**.*

*PRO TIP: The internal **6700 mAh** battery also works as a power bank with 2-way charging. Requires **USB-C cable** for 2-way charging (not included).*

8. Mounting and Leveling Camera to ORBIT

8.1. Moon Focus Ball and Leveling Camera

The **Moon Focus Ball** (Part #25) is installed to establish center point and focus of your subject. The **Arm Pole** that has the camera mounted should be raised/lowered so that the camera lens position is level with target (i.e., **Moon Focus Ball**).

1. Install the **Moon Focus Ball** to the center of the **Light Ring** and adjust the string up/down to level with the camera and then set focus on the ball with the camera.
2. Proceed with [Mounting the Camera](#) and [Counterweights](#) steps, then refer back to this section for next steps.
3. Once all necessary parts are installed and steps completed, set your camera to manual focus, focus on the moon, and adjust horizon level.
4. Remove **Ratchet Straps** (Part #40) if not already done before powering on the **ORBIT** and setting in motion. See [Composing the Shot](#) section for single and multiple subject scenarios.

Note: You do not need autofocus for most objects including human faces. If the subject is dead center, the focus around them will remain constant.

8.2. Mounting the Camera

⚠ WARNING: Always use a **Ratchet Strap** (Part #40) to ease strain on motor shaft when you are mounting a camera or counterweight to **ORBIT**.

Every kit comes with **¼ -20 threaded loops with curved edge** (Part #19), for attaching the **Ratchet Straps**. This is for loading/unloading only, not for use while **ORBIT** is in motion. The **Ratchet Strap** is good for up to 70 lbs. when ratcheted tightly for stability.

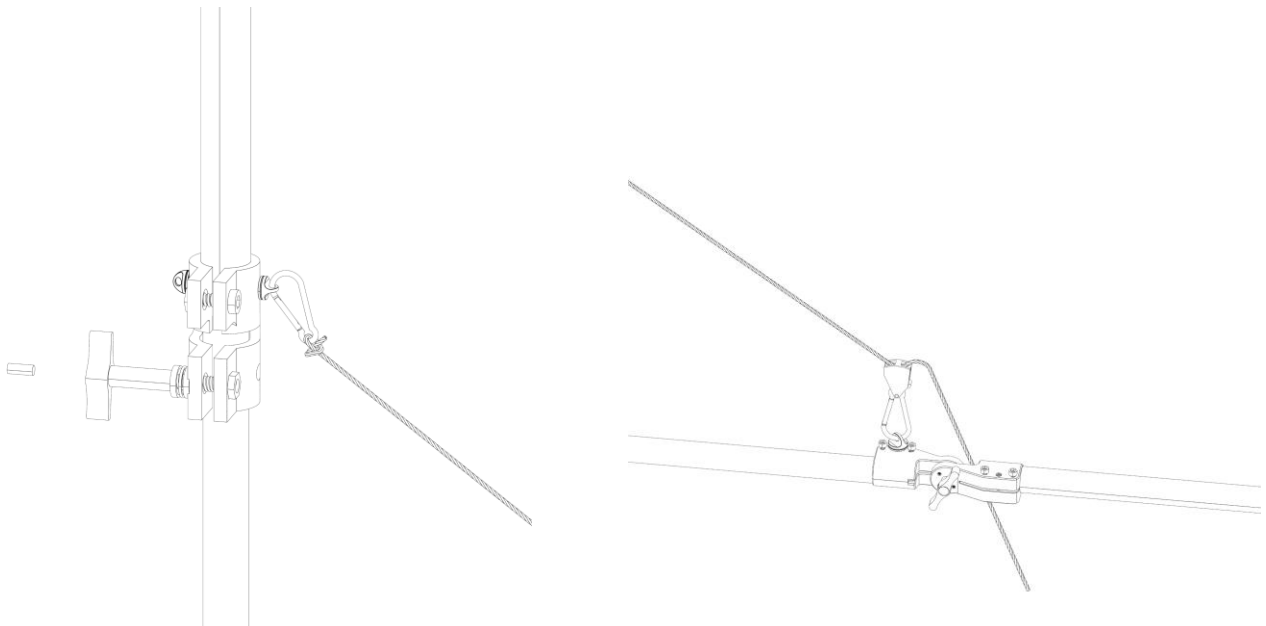


Figure 17: Ratchet strap installation and use

Use [Figure 17](#) above as a guide on how the Ratchet Straps are used while mounting camera and other equipment **ORBIT**.

Follow the steps below to mount camera equipment using the **Single Ball Head** and/or **Dual Collar Sleeve**.

1. Locate the **threaded end caps** (Part #19) removed previously from the 24" arm poles in [Section 6.5](#). Slide a **single knob bar sleeve** (Part #30) onto the end of one arm and tighten knob.
2. Screw the **threaded end cap** onto the end of the arm (See [Figure 18](#)).



Figure 18: Bar sleeve with 1/4"-20 mount (single knob)

3. Locate the **Single Ball Head** (Part #32) for the camera and screw it into the bottom of the **single knob bar sleeve** (Part #30). Slide the **Single Ball Head** hot shoe mount into the hot shoe of your camera. If your camera does not have a hot shoe, a **cold shoe mount** (Part #36) is included for quick release (i.e., Black Magic cameras).
4. Add even weight to balance and adjust **Counterweight(s)** and/or **Arm Poles** as you adjust the position and weight of camera to the opposite arm end.

⚠ WARNING: THE END CAP IS ONLY RATED FOR 3LBS. IT IS NOT RECOMMENDED TO THREAD ALL 6-LBS OF COUNTERWEIGHTS ON THE END OF THE BAR. THIS MAY CAUSE THE ENDS TO SNAP OFF AND RESULT IN DAMAGE TO YOUR CAMARA GEAR OR CAUSE BODILY INJURY.

5. Use the **Dual Collar Sleeve w/dual knobs** (Part #31) shown in [Figure 19](#) and included in the PRO Kit (also available for purchase from <https://www.marblorbit.com/store/accessories>) which can hold more than three (3) lbs. of counterweights.

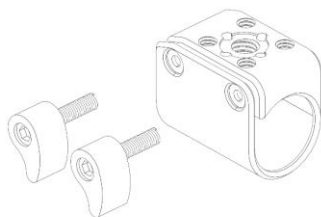


Figure 19: Dual collar sleeve with 1/4"-20 mount (dual knobs)

6. A small level is in the horizontal bar to fine-tune balance, but initially it's easy to eyeball and see what side is hanging too low or too high. An unbalanced payload on the **ORBIT** may lead to vibrations, increased motor noise and/or damaged motor mount. Check that the proper counterweighting is performed prior to operating the **ORBIT**.

IMPORTANT: It is recommended the camera payload and counterweight payload be balanced prior to turning on the **ORBIT** motor. Improper balancing can cause the **ORBIT** to be off-center, and potentially cause damage to the motor.

⚠ WARNING: MOTOR OR PARTS DAMAGED DUE TO IMPROPER BALANCING WILL VOID THE WARRANTY.

8.3. Counterweights

The Base and Studio kits each come with three (3) **counterweights** (Part #29) and the PRO Kit includes six (6) **counterweights**. The counterweights are:

- Male/Female threaded ¼-20
- Stackable (no more than three (3) counterweights on one end are recommended)
- Adjustable by adding/removing weight or by moving the **Arm Joint** closer or further from center



Figure 20: Counterweights

⚠ WARNING: DO NOT EXCEED RECOMMENDED PAYLOAD ON EACH ARM. RECOMMENDED PAYLOAD <10 LBS. ⚠

1. Each **counterweight** is 1 lb. each and can be threaded onto each other and threaded onto the **End Caps** of the **Arm Poles**. The **end cap** is only rated for 3 lbs.; therefore, it is not recommended to thread all 6 lbs. of counterweights on the end of the bar. Instead, use the **Dual Collar Sleeve** (Part #30) provided in the PRO kit (or order this extra accessory piece). The **Dual Collar Sleeve** can hold more than 3 lbs, so if more weights are needed, thread them on there.
2. Use the built-in **Magnetic bubble level** (Part #26) on the **Dual Arm Receiver** to measure balance. Add **counterweights** equal to the weight of camera and lens on the opposite arm end. Adjust the bend of the arm for additional adjustments to weight until the level is even.

*NOTE: Remember to remove the **Ratchet Strap** once you have added counterweights and prior to turning on the motor.*

What if more weight is needed?

If you have a BASE or STUDIO kit and a camera and lens combo that's more than 3lbs, or a PRO Kit with a camera and lens combo more than 6lbs, here are some possible options:

- Purchase additional counterweights from MARBL's online store <https://www.marblorbit.com/store/accessories>
- [Counterweights from other systems](#) - Top recommendation. Pricy, but only one is needed.
- [Sandbags](#) (not top recommendation, but this can be used with bottles of water instead of sand).
- [Ankle weights from Amazon](#) (Best Value). Simple and effective.

If using sandbags, be careful not to let them hang by the slack. It is better to drape one end over the bar. Otherwise, they will sway back and forth too much, and the momentum will cause vibrations and problems for modes like **Wiper mode**.

PREFERRED: It is best to have a counterweight system that is fixed and does not move.

Note: Accessory kit is in development! Check out <https://www.marblorbit.com/store/accessories> for parts availability.

8.4. Composing the Shot

8.4.1. Main subject – Center of focus

Determine your main subject and set focus using the **Moon Focus Ball** (Part #25) to determine center.

1. Set camera aperture and shutter speed and lens focal length. (i.e., 105mm)
2. Check camera monitor to see if there are obstacles in shot. If the **Light Ring** is in the shot, raise/lower the camera arm until **Light Ring** is no longer in the shot.
3. Level the camera axis as needed.
4. Check the opposite **Arm Joint** is not visible in shot, making the necessary adjustments to arms, T-handles, etc. to remove them from the shot.
5. Level the camera axis as needed.

8.4.2. Multiple subjects (i.e., main subject and secondary subject)

Determine your main and secondary subjects and set focus using the **Moon Focus Ball** to determine center.

1. Set camera aperture and shutter speed and lens focal length. (Adjust the lens to get all subjects in the shot i.e., 50mm)
2. Check camera monitor to see if there are obstacles in shot. If the **Light Ring** is in the shot, raise/lower the camera arm until **Light Ring** is no longer in the shot.
3. Level the camera axis as needed.
4. Check the opposite **Arm Joint** is not visible in shot, making the necessary adjustments to arms, T-handles, etc. to remove them from the shot.
5. Level the camera axis as needed.

9. Installing Additional Mounts and Accessories

9.1. Double Ball Head Mounting

The **Double Ball Head** (Part #33) adds extra camera angle adjustability. Attach one end to your camera's $\frac{1}{4}$ 20 thread and the other end to either the **Bar sleeve** (Part #30) or **Dual collar sleeve** (Part #31). Turn the T-handle counterclockwise until the ball joints are loose enough to move around. Adjust to desired camera angle and re-tighten by turning T handle clockwise.

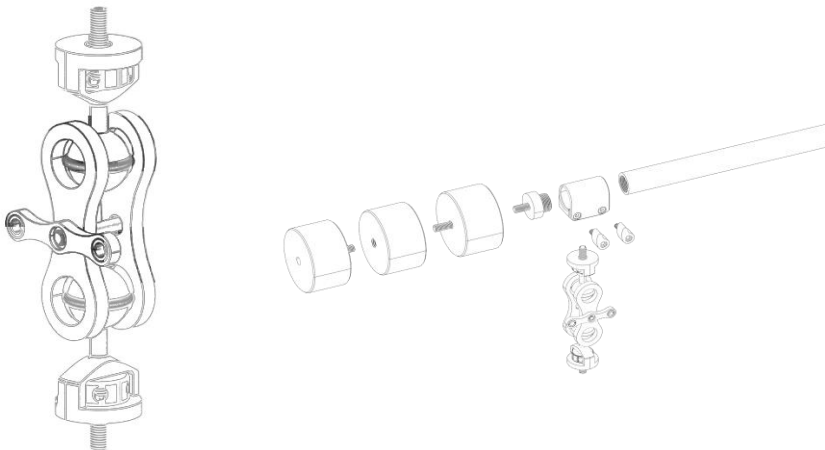


Figure 21: Double Ball Head

9.2. Secondary Camera Mount (i.e., iPhone or Android smartphone)

Locate the **Smart Phone camera mount** (Part #35). It can be threaded to any of $\frac{1}{4}$ 20" holes on the **collar sleeves**, the **threaded end caps** of the **arm poles** or the top of the **arm joints**. It can be used as a primary camera or secondary camera to catch behind the scenes action or alternate vantage points.

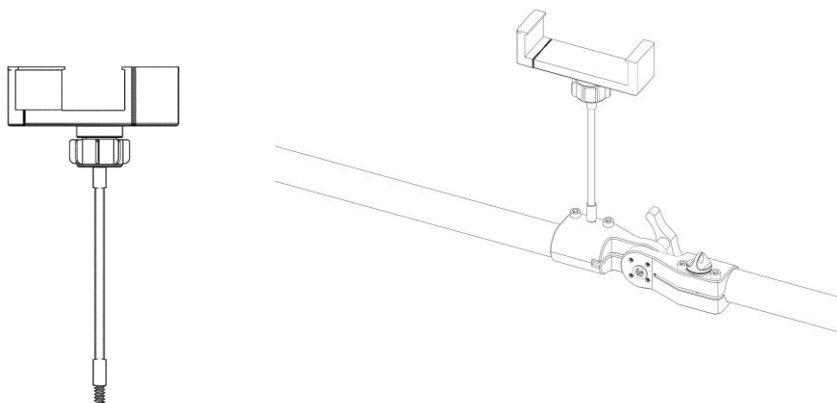


Figure 22: Smart Phone Camera Mount

9.3. V-Mount Bar Clamp and Quick Release (Pro Kit Only)

The **V-mount Bar Clamp and Quick Release** (Part #34). The quick release clamp allows you to attach a V-mount battery pack (not included) onto the orbit. Then use the included **D-Tap cables** (Part #44 & 45) to power Orbit motor, ring light, cameras, wireless transmitters and more from the V-Mount battery.

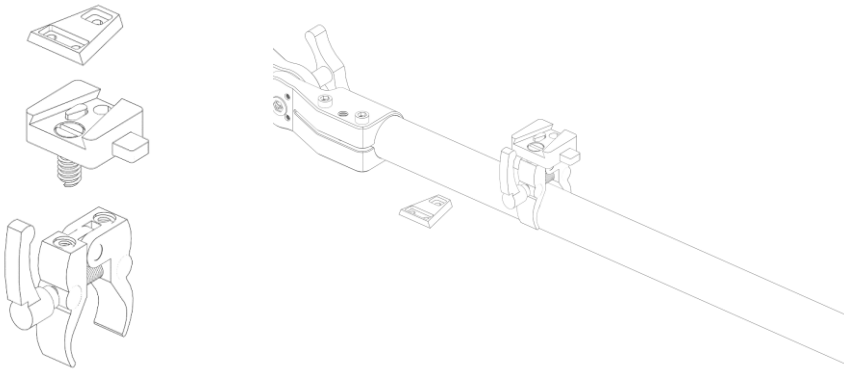


Figure 23: V-Mount Bar Clamp and Quick Release

10. Operating Your ORBIT and Light Ring

10.1. LED Light Ring (Included with Studio and PRO Kits)

The CRI97+ LED **Light Ring** features the following:

- Allen wrench **tool holder** on top.
- Two-way self-adaptive USB-C port for charging or for powering items. 5V-12V.
- ¼"-20 mount for accessories such as microphones, lights, or friction arm items.

The **Light Ring** (Part #21) has a physical power button and a pushable rotary knob to adjust brightness or activate the laser center. Most functions on the **Light Ring** are controllable with the **Remote Control** (Part #27).

Numbers coincide with the diagram below.



Figure 24: Light Ring Button and equipment descriptions

1. **POWER BUTTON** The power button will enable use of the **Light Ring** and store the last used settings when turned off.

Note: You will need to physically turn on the power button to use Light Ring specific buttons on the Remote Control.

Note: The Light Ring will go into standby if you turn it off from the Remote Control without hitting the physical power button on the Light Ring itself. It will exit standby within three (3) hours and shut itself completely off to save the battery.

2. **BATTERY INDICATOR:** The battery indicator displays charging status when the **Light Ring** is being charged via **12V Power cable** (included) or USB-C cabled (not included). A solid light indicates a stage of battery life that has completed charging. A flashing light indicates a stage of battery currently being charged. The unit is fully charged when all five (5) lights are solid.

Note: When running on battery the indicator lights will gradually turn off as a stage of charge has been depleted.

- 5 Solid lights = 81%-100% battery life remaining
- 4 Solid lights = 80% battery life remaining
- 3 Solid lights = 60% battery life remaining
- 2 Solid lights = 40% battery life remaining
- 1 Solid lights = 20% or less battery life remaining

- 3. LASER CENTER:** A 5W laser crosshair can be activated that is ideal for centering your subject or item below the **ORBIT** before filming. It will automatically turn off after 15 seconds. (See item #6 for button instructions)

⚠ WARNING: - DO NOT LOOK INTO TO THE LASER. STARING INTO THE LASER CAN CAUSE EYE DAMAGE.

⚠ WARNING: - DO NOT EXPOSE CAMERA LENSES TO LASER.

- 4. MAGNET FOR MOON BALL:** The **Light Ring** has a circular magnet surrounding the laser lens that can be used with the **Moon Focus Ball** for setting focus on skin tone or with the **magnetic bubble level** to check balance.
- 5. IR SENSOR FOR REMOTE CONTROL:** The Light Ring’s IR sensor enables the **Remote Control** to communicate. For optimal power, ensure that the **Remote Control** is within visual range of the IR sensor.

PRO TIP: Instead of walking under the Light Ring and pointing the Remote Control upward at IR sensor, try pointing the Remote Control down to the ground at an angle. You can use the ground as a mirror and bounce the IR signal from the Remote Control into the bottom of the Light Ring.

- 6. PUSH LASER ACTIVATE:** Double tap the step adjuster wheel to turn the laser cross hair ON/OFF.
- 7. ROTATE 30-STEP LIGHT ADJUSTMENT:** Rotate the step adjuster wheel to adjust brightness of the **Light Ring**. There are 32 steps of brightness when manually rotated. The **Remote Control** is limited to six (6) large steps of brightness.

10.2. Additional Light Ring Specifications:

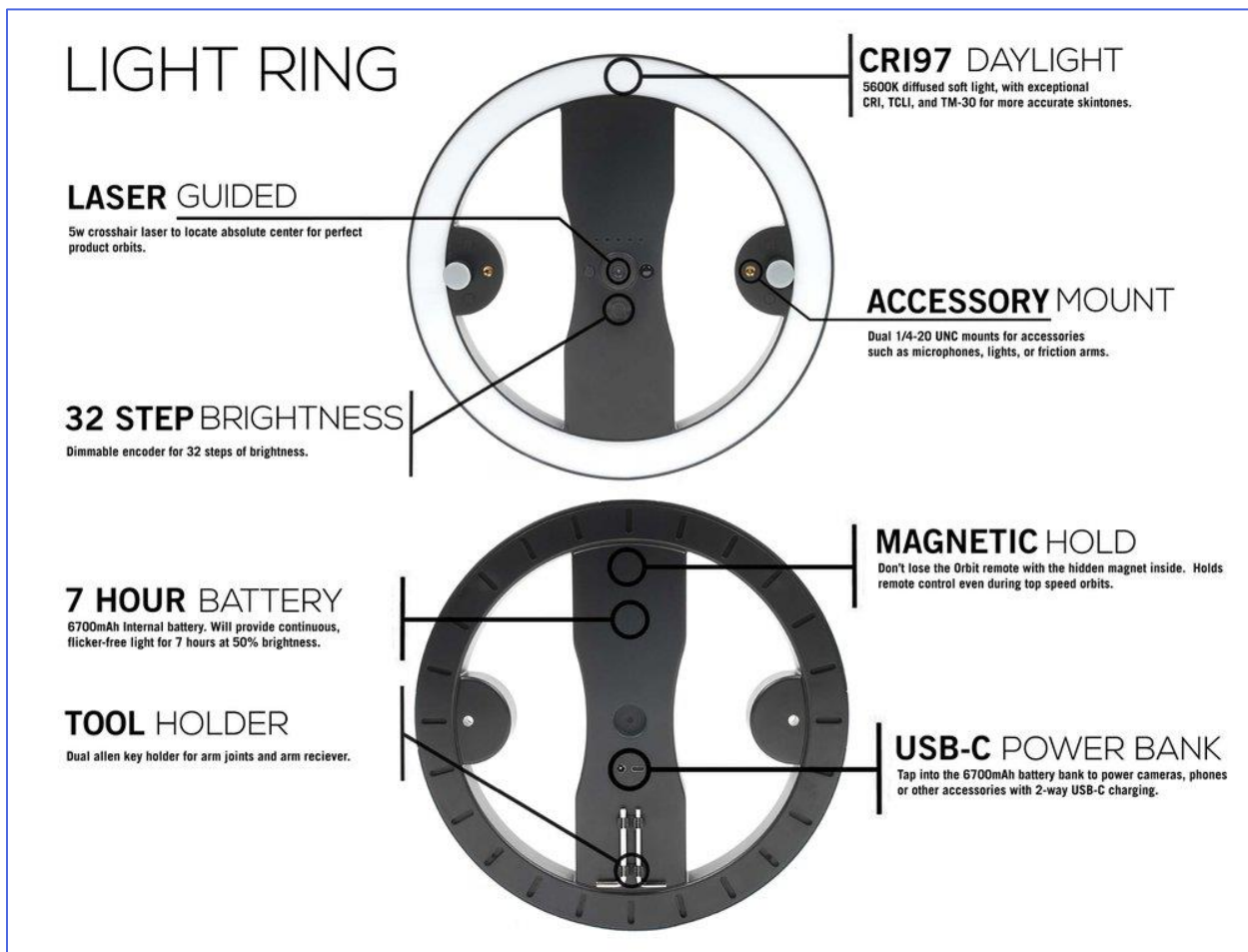


Figure 25: Light Ring top and bottom features

11. Remote Control

Gently unscrew the battery bay cover on the back of the **Remote Control** (Part #27) and remove the plastic protector before attempting to use the Remote Control.

Note: Do not lose the Remote Control. (Studio and PRO Kit only) Use the magnetic top portion of the Light Ring opposite the tool holder for convenient storage of the Remote Control.

The **Remote Control** operates both the **ORBIT motor** and the **Light Ring**.

LIGHT RING

OPERATES:	YES	NO
Remote Control	✓	
Buttons on Light Ring exterior	✓	
App Control		✓

ORBIT

OPERATES:	YES	NO
Remote Control	✓	
Buttons on exterior (Other than Power button)		✓
App Control	✓	

11.1. Remote Control Operation and Guide

The top four (4) buttons on the **Remote Control** (Part #27) operate the **Light Ring** (Part #21) and the dial and bottom four (4) buttons operate the **ORBIT motor** (Part #9).

ORBIT has a Wi-Fi based application that creates a digital version of this remote control. [See Section 13](#) for more information or view on Marbl website with this [App Link](#).

ORBIT Remote Control

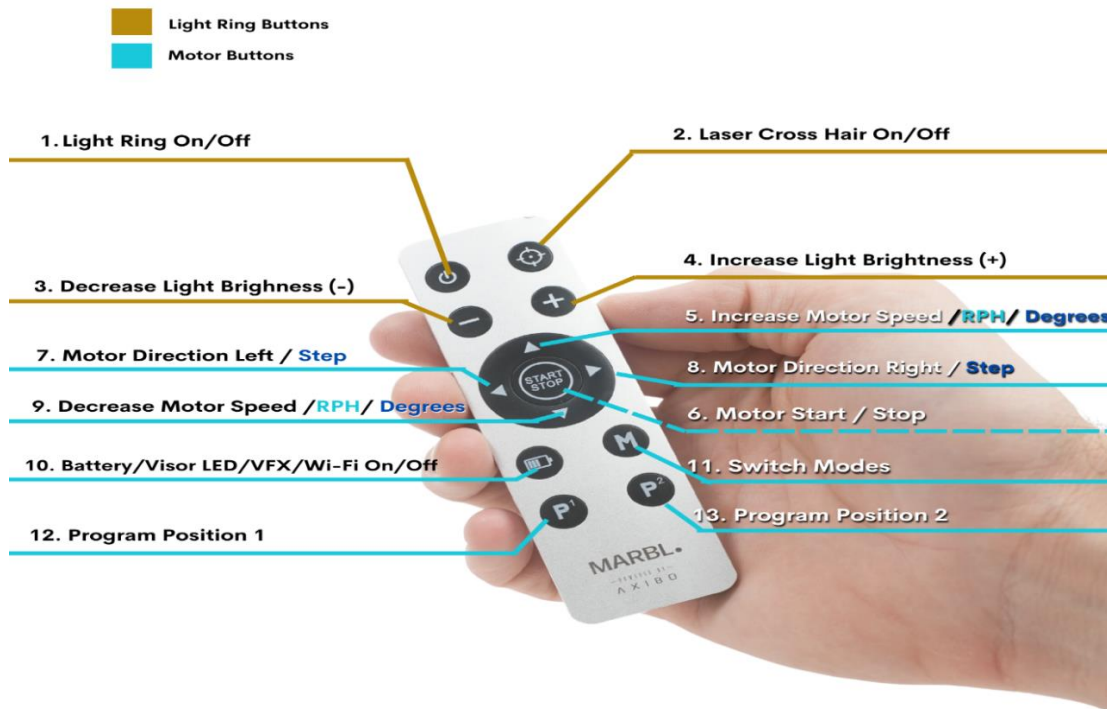


Figure 26: Remote Control Button Guide

LIGHT RING CONTROLS

- 1. LED Light Ring On/Off**
 - Pressing once turns Light Ring ON.
 - Pressing again, turns Light Ring OFF.
- 2. Laser Crosshair On/Off**
 - Double Press: Laser turns on for 15 seconds, then automatically turns off.
 - Pressing again before it turns off will turn off laser faster.
- 3. Decrease Light Ring Brightness (-)**
 - Decreases Light Ring brightness up to six (6) steps brightness (0%, 1%, 10%, 25%, 50%, and 100%)
- 4. Increase Light Ring Brightness (+)**
 - Increases Light Ring brightness down to six (6) steps brightness (0%, 1%, 10%, 25%, 50%, and 100%)

PRO TIP: If the Light Ring doesn't respond to Remote Control functions, then you may be out of visible range of the IR sensor which is located on the underside of the Light Ring near the controls. Either get under the Light Ring and point the Remote Control up at the sensor or try pointing the Remote Control down to the ground at an angle and try commands again. Often you can use the ground as a mirror to bounce the IR signal into the IR sensor on the bottom of the Light Ring.

MOTOR REMOTE CONTROL

The **Remote Control** sends commands to the **ORBIT motor** via the IR sensors on either side of the Motor. Point the **Remote Control** at either of the side sensors to operate the **ORBIT**. Do not point the **Remote Control** at the power button on the front or the speaker grill on the back of the **ORBIT** as they are out of IR sensor’s field of view.

*PRO TIP: If **ORBIT** is not responding to Remote Control commands try pointing the Remote Control at a nearby wall to bounce the signal into the IR receiver from the side or try the Wi-fi app.*

Note: The IR sensor may be susceptible to other **Remote Control** interference. See [Troubleshooting](#) section.

The **Motor** flashes white each time a successful command is received from the **Remote Control**.

MOTOR SPEED:

ORBIT will reduce MAX RPM as the battery depletes to optimize the motor performance. (See Chart)

- Max Speed = 10RPM
- Min Speed = 1 Rotation per 48 hours

BATTERY LIFE	MAX RPM
60%-100%	10
50%	5
40%	4
30%	3
20%	2
10%	1

Table 1: Battery Life and MAX RPM

VISOR COLORS/MODES:

Toggleing the “M” button on the Remote Control will cycle through the modes.

LED COLOR	ACTION/MODE	DESCRIPTION
RED	STOP	No motor movement – Locked position.
GREEN	PRODUCT	Product mode – Operates from ½ RPM to 10 RPM
YELLOW	INTERVIEW	Interview mode – Slower than product (1/30 th to 10 RPM)
TEAL	TIME LAPSE	Time Lapse mode – Slowest mode. One rotation every ½ hr to 1 rotation every 48hrs.
DARK BLUE	STOP MOTION	Stop Motion Mode – Moves by degrees on direction press at a fixed speed of ¼ RPM.

Table 2: Visor Colors/Modes

5. Increase Motor Speed / RPH (Rotation per hour)/ Degrees Increase

- Press the START/ STOP button, then push opposite direction to retain the Motor Speed.
- Speed increase works in **Product**, **Interview**, and **Time Lapse** modes
- **Stop Motion** Mode – Increase / Decrease only allows you to set movement in degrees (0.5°, 1°, 2°, 5°, 10° or 15°) Orbit will move to specified degree at a set speed of 0.25 RPM
- **Product** Mode – 1/2 RPM
- **Interview** Mode – Approximately 1/30th RPM or .03RPM
- **Time Lapse** Mode – 1 RPH (Rotation per (0.5, 1, 3, 6, 12, 24, 48) Hours)

6. Motor Start / Stop

- Press once to start motor with last used speed /direction, except after start-up. Reboot resets mode / speed information.
- Press once when motor is moving to bring motor to a gradual stop.

7. Motor Direction Left / Step

- Motor direction to the left (counterclockwise).
- If motor is spinning to the right (clockwise), this brings **ORBIT** to a gradual stop, then reverses direction, with same speed setting.

8. Motor Direction Right / Step

- Motor direction to the right (clockwise).

9. Decrease Motor Speed / RPH (Rotation per hour) / Degrees Decrease (Refer to Table)

- Speed increase/ decrease only works in **Product, Interview, and Time Lapse** modes
- **Skip to max / min speed allowed by battery level.** Select mode then make sure **ORBIT** is stopped and visor color is red.
- Press UP arrow 2X to start **ORBIT** in max speed. Conversely press DOWN arrow 2X fast to go to lowest speed. This setting only works in **Product** and **Interview** modes. When pressed the opposite direction, the speed will slowly stop and begin to rotate in the opposite direction at the same motor speed. You can also accomplish direction change by pressing the START/ STOP button selecting a direction.

10. Battery Indicator / Visor LED / VFX / WiFi On/Off:

- **When pressed once:** Displays Battery level by flashing GREEN, ORANGE, or RED.
 - **GREEN FLASH** – 70% or more battery life remaining.
 - **ORANGE FLASH** -30% to 69% battery life remaining.
 - **RED FLASH**- Less than 29% Battery remaining.
- **Disable LED Visor**
 - 2X: Press Battery Button two times fast.
- **Disable/Enable VFX Blip**
 - 3X: Press Battery Button three times fast.
- **Enable/Disable Stealth Drive** (Turn off Wi-fi for silent operation under 3 RPM)
 - 4X: Press Battery Button four times fast.
 - *Note: This will deactivate use of the app until you use this function on the remote to reactivate wi-fi or hard reset the **ORBIT Motor** with power button.*

11. Switch Mode Button (M)

Each press of the (M) button cycles to the next mode until it cycles back to default (Product) mode. Modes will cycle Product (Green), Interview (Yellow), Time Lapse (Teal), Stop Motion (Blue).

12. Program Position 1 “P1”

- Program / Recall
- P1/P2 Enables Wiper Mode – **ORBIT** moves back and forth automatically between the two positions. Ideal for interviews.
- Single press P1 to program the current location. Use this in any of the speed modes, when visor is Green, Yellow, or Teal, to retain the current speed but will lock the location and reverse the direction of the **ORBIT**.

13. Program Position 2 "P2"

- Program / Recall
- Single press P2 to program the current location. Use this in any of the speed modes, (when visor is green, yellow, or teal) to retain the current speed but will lock the location and reverse the direction of the **ORBIT**.
- When programming: immediately after programming P1, this will mark the second location and the **ORBIT** will switch between the two positions.
- You can change speeds like normal, by using the up/down buttons.
- The LED visor on **ORBIT** will pulse when wiper function is active.
- To escape wiper mode press P1, then P2 quickly, or restart the **ORBIT** with power button.

MODES EXPLAINED:

Stop Motion Mode (LED = Navy Blue):

- Default increments 0.5 Degrees
- Deactivates moving by hand
- Moves direction Left / Right

Up/ Down Arrows

- 0.5 degrees / 720 x = 1 rotation
- 01 degrees / 360 x = 1 rotation
- 2 degrees / 180x = 1 rotation
- 5 degrees / 72 x = 1 rotation
- 10 degrees / 36x = 1 rotation
- 15 degrees / 24x = 1 rotation

12. Outdoor Assembly (ORBIT PRO Kit)

The Pro version includes speed rail adapters that interact with C-Stands and Speed Rails to bring the **ORBIT** outside. C-Stands and Speed Rails are not included with the ORBIT kits.



Figure 27: Outdoor installation example

12.1. Outdoor Bracket Assembly

Follow the steps below to assemble the **Speed Rail adapters** (Part #39) and **Baby Pin** (Part #38) to support rails.

1. Thread the bolts through the holes on the top of the adaptor plate down into the center of the baby pins. Then connect each pin to your C-Stand. (See images in [Figure 28](#) below.)



Figure 28: Attaching Baby pin to Speed Rail adapters

2. **Mounting Motor directly to Speed Rail Adaptor:** Mount the **ORBIT motor** directly to the middle **speed rail adaptor** by sliding the threaded motor mount on the top of the **ORBIT** through the hole on the **speed rail adaptor**. Fasten the **spring washer** and **bolt** to the **speed rail** using the **19mm wrench** (See [Figure 29](#)).



Figure 29: ORBIT mounted directly to speed rail adaptor

3. **Using Telescoping Down Rod with Speed Rail Adaptor:** Then use the Telescoping Down Rod with the speed rail adaptor, attach the Ceiling Plate with included bolt then attach the Telescoping Down Rod to the Ceiling Plate and tighten as you did in section 6.3. (See [Figure 30](#)).



Figure 30: Attaching Ceiling Plate and Telescoping Down Rod to Speed Rail adapter

Speed Rail Recommendations:

Speedrail is also known as Schedule 40 1-1/4 aluminum rail. This is aluminum tube used for banisters and railings and can be sourced at any metal manufacturing supply house in the USA. It is available in a few different sizes, but the outdoor brackets included in the Pro kit currently only fit the standard USA speedrail size. The measurements are 1.66" OD (outside diameter).

MARBL ORBIT Recommended Stands for outdoor filming PRO Kit:

- Matthews Medium Overhead Roller Stand – [Available on B&H Photo Video](#) (in Chrome or Black) - \$\$\$ Pricey, but they fold up nicely, and have a very wide base with very smooth wheels. It's the ultimate stand for a serious outdoor filming project, given the height options, mobility factor, and the stability of the base.

12.2. Truss Assembly

The Truss Assembly allows for a modular solution where the Truss pieces can be shorter pieces designed for more mobility (i.e., 3-4' length trusses). This setup utilizes the mounting plate portion of the included Outdoor Brackets from the PRO kit.



Figure 31: Outdoor Bracket

Refer to [YouTube](#) video for assembly of Truss sections.

Along with purchasing Truss sections, this requires additional connectors to bridge the gap between sections of Truss. See example of single Truss section in [Figure 32](#).



Figure 32: Truss section

Truss and Connecting Part Recommendations:

- F32 Global Truss (IB-4049) 3.28ft (1m) <https://amzn.to/3L3pkjx> (Longer lengths are available)
 - 10-Pack of 2-Inch Stage Light Truss Clamps (hold the Outdoor kit plates to the Truss) <https://amzn.to/3Jwv5pL>
 - Hex Head Bolts to connect the Stage Light Clamps to the Pro Kit Plates (the clamp screws are too large without modifying the plate which I chose not to do) <https://amzn.to/36cjMEN>
 - Wingnuts, ¼"-20, for the above bolts. This package has 50qty. <https://amzn.to/3isjdJj>
 - 10-Pack 8mmx20mm, Male Thread Plastic T-Handles for the Baby Pin to Secure the Outdoor Plate to the Stand Pin. (These parts are currently not included in the Pro Kit – purchasing this pack will give you extras but purchasing singles would be more expensive) <https://amzn.to/3tvCeAW>
1. Assemble mounting plate with clamps to end sections of two Truss pieces. These will serve as the supporting ends to connect to C-stands.
 2. Once Truss sections are assembled with mounting plates and baby pins, the assembled Truss can be installed on sturdy C-stands (rolling or stationary). **⚠ WARNING: Recommend two people for lifting and installing on the stands.**
 3. Locate the midpoint of the Truss rail to install the remaining Truss Clamps. Connect the Truss Clamps loosely to utilize the plate for levelling. *Note: Pick sections of the Truss that do not have the cross-member support beams.*
 4. Install the mounting plate to the Truss Clamps and tighten clamps and level the plate.
 5. Install and tighten the **Ceiling Plate** to the middle mounting plate just installed along with the 2 ½" bolt and nut included with PRO kit.
 6. Check levels on each end and raise/lower C-stands to maintain level on each end and to the height needed for your application. The **ORBIT** requires all sections and ends to be level so that your subject remains in the same relative position while it is orbiting. **⚠ WARNING: Recommend two people for raising/lowering stands for leveling.**
Note: For future installations, mark parts that fit well together and desired height levels to speed up installation process.
 7. Refer to **ORBIT** Assembly steps with or without **Telescoping Down Rod** and subsequent installation steps of the **ORBIT** motor, **Dual Arm Receiver**, **Arm Poles**, and **Light Ring**.

13. MARBL App

<http://www.marblorbit.com/app2>.

ORBIT APP HAS ARRIVED



The ORBIT Overhead Camera Dolly system connects any Wi-Fi enabled device using its own private network. The web-based app can be connected and used anywhere, off-line, any time with no internet or cellular data required.

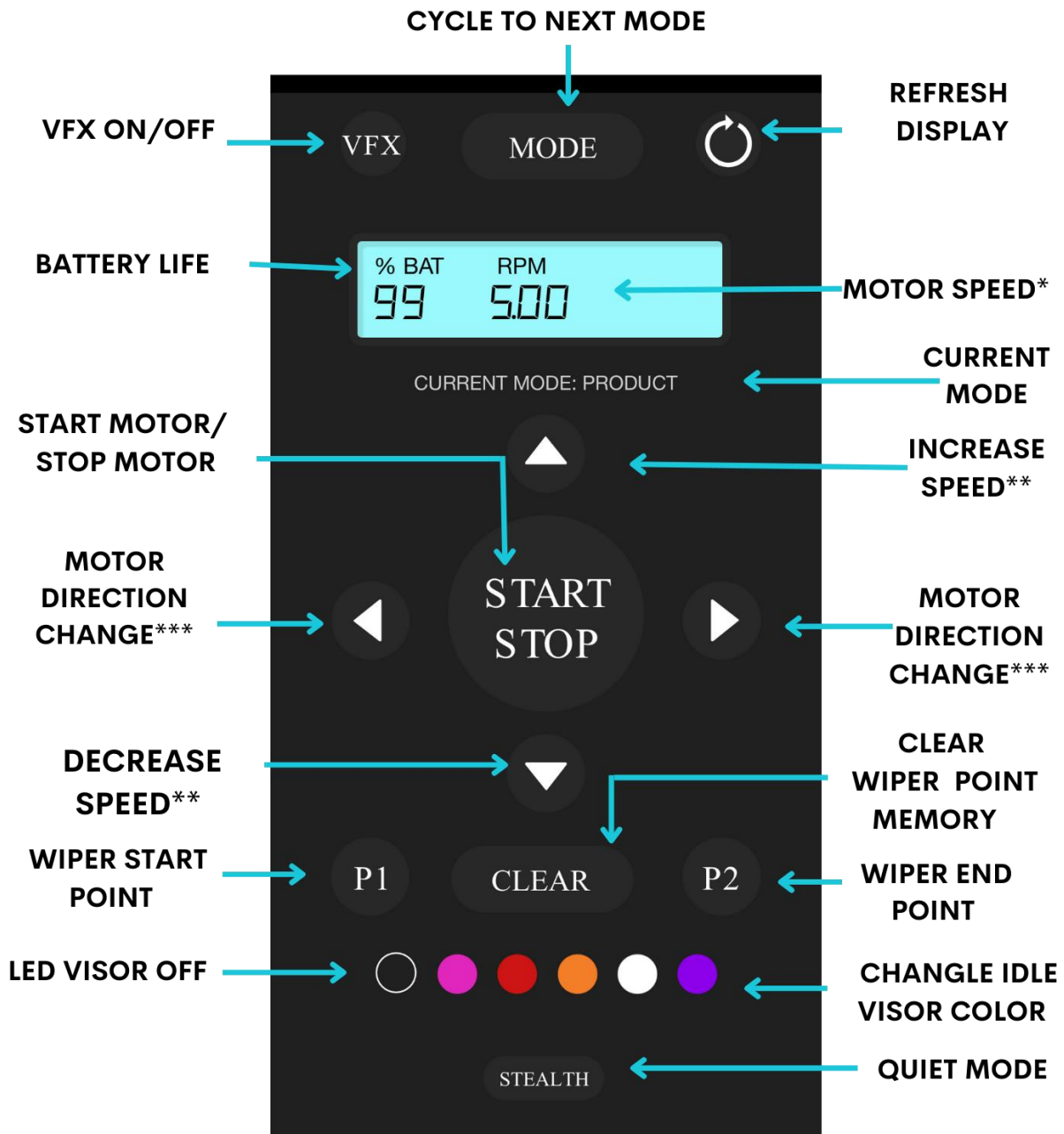
⚠ IMPORTANT: ORBIT requires *Firmware V0028 or higher update* to enable Wi-Fi app connectivity. ⚠

- Wi-Fi Signal range is approximately 40ft from **ORBIT Motor**.
- App doesn't control any function on the **Light Ring**.
- Most buttons on the app are programmed to operate similarly to the IR remote.
- Stealth button will turn off Wi-Fi to optimize **ORBIT** for silent operation. A hard reset or remote control will be required to re-establish a Wi-Fi connection and app control.
- **ORBIT** App may restrict cellular data transfer on your mobile device when in use.

How to set up Wi-Fi enabled device to work with Orbit.

1. Turn on **ORBIT**.
2. Search available networks on your Wi-Fi connected device for "MARBL."
3. Click connect and enter Password: **Marbl12345** (case sensitive) *Note: Android devices may require you to select "stay connected to Wi-Fi regardless" after selecting the MARBL. Wi-Fi network.*
4. Open a web browser and enter <http://192.168.4.1>
5. Add URL to home screen, desktop and/or bookmark in your internet favorites for future use.

APP BUTTON DIAGRAM



*INCREASE/DECREASE SPEED displayed differently in Time Lapse/ Stop Motion Modes

**INCREASE/DECREASE SPEED functions differently in Time Lapse and Stop Motion mode

***MOTOR DIRECTION CHANGE Button functions differently in Stop Motion Mode

Figure 33: MARBL APP Button Diagram

SECTION A.

Buttons Explained:

Note: ORBIT has four (4) modes: PRODUCT, INTERVIEW, TIME LAPSE AND STOP MOTION. Some buttons have different functions in TIME LAPSE and STOP MOTION Modes. Those differences are explained in individual sections below. Digital readout displays change to reflect different units of measure in each mode.

VFX: Turns on an audible static blip every time **ORBIT** makes a full rotation. Ideal for use when editing video and stacking rotation clips. Tap to turn VFX off. You can also activate/deactivate IR from the remote control by pressing battery button 3X.

MODE: Cycles through PRODUCT, INTERVIEW, TIME LAPSE AND STOP MOTION individually each time this button is pressed. The selected current mode will appear in the CURRENT MODE area under the digital readout display.



: Refreshes connectivity to the app. Press this button to refresh the browser and send updated information to the app. *Note: Minimizing the ORBIT app may disengage control of ORBIT. Use the refresh button after returning to the app and/or try reconnecting your device to the MARBL Wi-Fi.*

BATTERY LIFE: Displays battery life. Max RPMs' will be limited based on battery life. Refer to [Sections 10.1](#) and [11.1](#) for more details.

MOTOR SPEED: The current motor speed is displayed in RPMs in PRODUCT and INTERVIEW modes only. TIME LAPSE and STOP MOTION modes will display different speed or movements in digital readout display. (Refer to [SECTION B.](#) and [SECTION C.](#) for more info.)

START/ STOP: Starts motor or Stops motor. Displayed on **ORBIT** LED Visor as a Green light for start and a Red light for stop.

INCREASE SPEED/ DECREASE SPEED: Adjusts motor RPM in PRODUCT and INTERVIEW modes.

MOTOR CHANGE DIRECTION LEFT: Activates clockwise rotation or slows then reverses an active counterclockwise rotation.

MOTOR CHANGE DIRECTION RIGHT: Activates counterclockwise rotation or slows then reverses an active clockwise rotation.

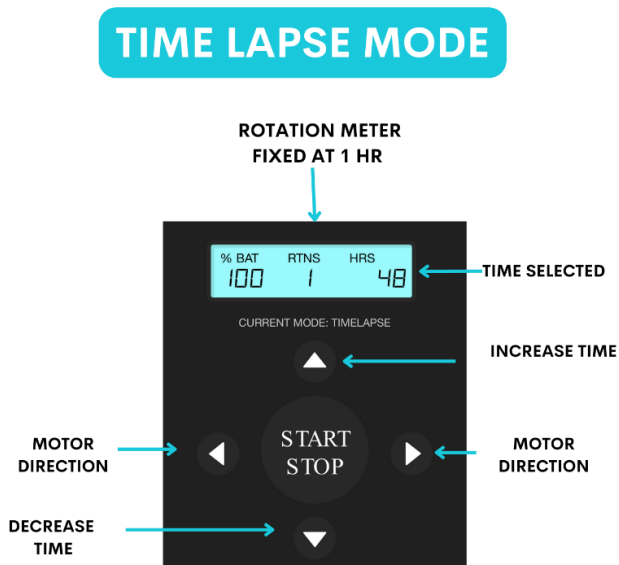
P1/P2: The **ORBIT motor** can be programmed to move back and forth between two pre-programed points called wiper function. Pressing P1 once will program the start point for wiper function. Pressing P2 will program a stop point for wiper function. Wiper mode will display as a pulsing light on the LED Display to pulse when active.

CLEAR: Wiper mode will persist even after you change modes. Use the CLEAR button to get out of Wiper function and back to normal operation. The LED visor will no longer pulse if you have disengaged wiper mode. *Note: This clear function can also be performed on the Remote Control by pressing P1 then P2 quickly.*

CHANGE IDLE VISOR COLOR: ORBIT switches to idle when an active motor has been stopped. This is displayed as red on the visor. You can change the idle color from red to magenta, orange, white, and purple. Restore default color schemes by selecting the red button.

LED VISOR OFF: The visor light can be turned off from idle by tapping the empty circle on the far left of the LED VISOR COLOR options. The LED visor can be turned back on by tapping the empty circle again or by selecting an IDLE VISOR COLOR. **Note:** *You can turn off the visor light on the Remote Control by pressing battery button 2X.*

STEALTH: This button activates an ultra-quiet motor movement under 3RPM. This feature is most commonly used for interviews where the microphone might pick up unwanted operating noise. The **ORBIT** will shut off Wi-Fi to optimize its systems for silent operation. Any active mode will continue to operate after STEALTH button is hit however all future control will require use of the included Remote Control.



All other buttons are unchanged for this mode

Figure 34: MARBL APP Time Lapse Mode

Note: STEALTH function can be deactivated by clicking the battery button 4X quickly on the IR remote control or through a hard reset.

SECTION B.

TIME LAPSE Mode Explained:

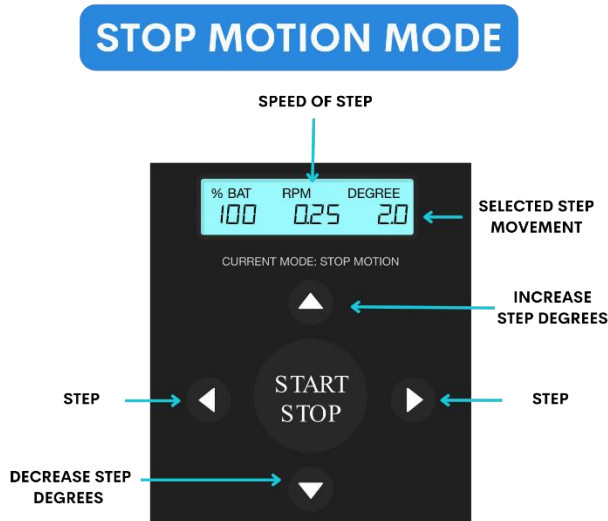
ORBIT features time lapse programming that enables how long it takes to complete one full rotation.

ROTATION METER: Display of how many rotations can be made are fixed at 1 RTNS (Rotations)

TIME SELECTED: Displays current selected time frame that **ORBIT** will take to complete one full rotation. Display will be in HRS (hours) or MINS (minutes) the current selected time frame for **ORBIT** to complete one full rotation.

INCREASE TIME/ DECREASE TIME: Adds or reduces the amount of time that it takes to complete one full rotation. Times are preset at 30min, 1 Hsr, 3hrs, 6Hrs, 12Hrs, 24hrs, 48hrs.

MOTOR DIRECTION: Sets the motor direction clockwise or counterclockwise for time lapse. *Note: We recommend that you to hit a direction button prior to hitting the START/STOP button to begin the time lapse rotation.*



All other buttons are unchanged for this mode

Figure 35: MARBL APP Stop Motion Mode

SECTION C.

STOP MOTION Mode Explained:

ORBIT features the ability to move and stop the **ORBIT** on command in tiny distances known as STEPS. STEPS which are measured in degrees on the **ORBIT** can be used to create 360 degrees stop motion content.

SPEED OF STEP: Displays the speed that the **ORBIT** will travel to a step when selected. Speed can't be changed and is fixed at 0.25 RPM.

SELECTED STEP MOVEMENT: Displays the selected degrees that the **ORBIT** will rotate when prompted.

INCREASE STEP DEGREES / DECREASE STEP DEGREES: Increase or decreases the distance the orbit will rotate before stopping. Preset degree step options are 0.5, 1, 2, 5, 10, and 15.

STEP left: Will rotate the camera clockwise by the programmed step and stop until pressed again.

STEP right: Will rotate the camera counterclockwise by the programmed step and stop until pressed again.

14. Troubleshooting and MARBL Support

14.1. Troubleshooting

Below are general problems and solutions you can try before contacting MARBL Support. If any of the solutions do not resolve your problem or your issue is not listed here, please contact MARBL Support ([Section 14.2](#)).

TYPE	PROBLEM	SUSPECTED ISSUE	SOLUTION
INSTALLATION	The Ceiling Plate is not level.	The ceiling may not be perfectly even or level.	Use a level and place shims under the Ceiling Plate until it sits completely flat and level.
INSTALLATION	The arm joint allen bolts are stripped.	You are tightening them down one at a time putting too much force on the threading.	Tighten each screw a little at a time until all four are tight. Be gentle with the allen key. If the key loses bite use a sharper allen key.
INSTALLATION	Arm poles feel loose in the crossbar.	Arm Pole(s) not fully seated and secured in the cross bar.	Fully loosen the two Allen screws that hold the arm into the crossbar. Force the bar into the crossbar until it can no longer move. Re-tighten the Allen screws.
INSTALLATION /BALANCE	The Dual Arm Receiver level does not show level.	Your counterbalances do not match camera weight.	Add or remove weights until level reads level
INSTALLATION /BALANCE	The camera bounces while rotating.	The camera has not been balanced properly.	Adjust the counterweight by a combination of adding or subtracting weight and adjusting counterweighted arm until the motion steadies.
MOTOR / POWER	The ORBIT won't turn on.	The battery is dead or was disconnected.	Charge the battery for several hours. If the problem is not resolved by charging, contact Customer Service for assistance with checking the battery connections.
MOTOR / POWER	The motor jolts and is noisier than normal at certain speeds.	The battery may be too depleted to power the unit properly and is causing issues such as abnormal sounds or motor abnormalities.	Charge the battery, consider using a V-mount battery to extend battery operation, or route the included 12V Power Cable wires away from moving cross bar and plug into an outlet. Verify you have the most current firmware update .
MOTOR / POWER	Motor makes a clicking noise.	ORBIT Motor may need rebalancing of counterweights and or hard reset.	Check to make sure that you have balanced the unit properly. Perform a hard reset if balancing does not resolve the issue. Verify you have the most current firmware update .
POWER	The ring light flickers.	The battery level is too low.	Charge the Light Ring with the included power cable until the indicator lights depict a full charge.

TYPE	PROBLEM	SUSPECTED ISSUE	SOLUTION
REMOTE CONTROL	The Remote Control does not work at all out of the box.	The plastic strip in the battery bay of the Remote Control is preventing electrical contacts from touching the battery.	A plastic strip is placed inside the Remote Control battery bay to prevent any battery discharge during shipping. Remove the circular battery cover on the back of the Remote Control and remove the plastic strip and re-install cover.
REMOTE CONTROL	ORBIT (sometimes) does not respond to Remote Control commands.	The Remote Control is not pointing close enough to the IR receivers on either side of the ORBIT .	The IR receivers occasionally create dead spots at the front and back of the ORBIT . Point the Remote Control to the IR receivers on the sides of the ORBIT .
REMOTE CONTROL	The Remote Control does not activate the light ring.	The Light Ring button has not been switched on prior to operating the Remote Control or user is out of IR range.	Power on the Light Ring using the physical push button on the Light Ring itself. The Remote Control will then operate the Light Ring . The IR sensor for the Light Ring is near the power button on the bottom of the unit that faces the ground. Position the Remote Control underneath the light ring to send the signal upwards into the IR sensor to prevent being out of range.
REMOTE CONTROL	Other Remote Controls from other cameras or IR Remote Controls are activating features on the ORBIT.	Other Remote Controls may be causing interference with the IR sensors on ORBIT .	Operate non- ORBIT devices manually. If you must use another IR device around ORBIT , then be sure to point its Remote Control away from any IR sensor on the ORBIT .
WI-FI APP / BLUETOOTH	The Wi-Fi app doesn't work with the light ring.	The Light Ring has no Bluetooth/Wi-Fi functionality by design.	Fine-tune light intensity using the physical adjustment wheel button on light ring. Limited Remote Control adjustments can also be made using the Remote Control .

14.2. MARBL Support

Don't forget to register your **ORBIT**!

[Click here to register your Orbit now.](#)

If you need parts or service assistance, please contact us at the contact information listed below:

MARBL ORBIT	
EMAIL:	support@marblorbit.com
WEBSITE:	http://www.marblorbit.com/
PHONE NUMBER:	+1 800.451.5569
MAIL:	PO Box 5713, Scottsdale, AZ 85261 United States

14.3. Care of Your ORBIT

Here are some suggestions to help you maintain your **ORBIT**:

1. Because of the **ORBIT**'s natural movement, some connections may become loose over time. Periodically check the support connections, brackets, screws, bolts, etc. at least twice a year. Make sure all items are secure.
2. Clean your **ORBIT** periodically to help maintain its new appearance over the years. Use only a soft brush, air can or lint-free cloth to avoid scratching the finish. Do not use water when cleaning. This could damage the **ORBIT motor** or finish, or possibly cause an electrical shock.

 **IMPORTANT: MAKE SURE THE ORBIT IS POWERED OFF BEFORE CHECKING CONNECTIONS OR CLEANING.** 

15. Replacement Parts

Refer to <https://www.marblorbit.com/store> for ORBIT Kits and replacement parts.

15.1. MARBL ORBIT Accessories

Refer to <https://www.marblorbit.com/store/accessories> for accessories.

16. Warranty

16.1. Part A – Limited Warranty

These MARBL LLC After-Sales Policies (these “Policies”) only apply to MARBL LLC products that you purchased from MARBL LLC authorized retailers for your own use and not for resale.

English is the prevailing language for all MARBL LLC warranties unless otherwise provided for in an alternate language.

By using your MARBL LLC product, you agree to be bound by these Policies. If you are not eligible or do not agree to any of the Terms, do not use your MARBL LLC product. You may be entitled to a full refund of your purchase of the Product if you return the inactivated Product within five (5) days in accordance with Part C of these Policies.

What is Covered

Under this Limited Warranty, MARBL LLC warrants that each MARBL LLC product that you purchase will be free from material and workmanship defects under normal use in accordance with MARBL LLC’s published product materials during the warranty period. MARBL LLC’s published product materials include, but not limited to, user manuals, safety guidelines, specifications, in-app notifications, and service communications.

The warranty period for different products and parts varies, please check www.marborbit.com/warranty to verify the duration of the warranty for your particular product or parts. The warranty period for a product starts on the day such product is delivered. If you cannot provide invoice or other valid proof of purchase, then the warranty period will start from 90 days after the shipping date that shows on the product, unless otherwise agreed upon between you and MARBL LLC.

How to Obtain Warranty Service

If a product does not function as warranted during the warranty period, you may obtain after-sales service by contacting MARBL LLC’s local service center as provided in Part C of these Policies or through <http://www.marbl.com/support>. You will need to provide a valid proof-of-purchase, receipt, or order number (for MARBL LLC Direct Sales) for the warranty service.

Charges may apply for services not covered by this Limited Warranty. Please contact MARBL LLC for information specific to your unit and location.

Please note that the warranty service is only available in the respective MARBL LLC service regions where you purchased your MARBL LLC product.

What will MARBL LLC do

MARBL LLC will attempt to diagnose and resolve your problem by telephone, e-mail, or online chat. MARBL LLC may direct you to download and install particular software updates.

If your problem cannot be resolved over the telephone or through the application of software updates, you may be required to deliver the product to MARBL LLC for further examination. MARBL LLC will arrange for repair or replacement service at no cost if the problem falls under this Limited Warranty. In most cases repairs can be performed quickly by the end user with simple to replace parts. Often times MARBL LLC will opt to send replacements parts first before requesting that a product be sent in for repair.

It is your responsibility to remove or backup any removable media or parts, data, software, or other materials you may have stored or preserved on your MARBL LLC product. It is likely that any media or parts, data, software, or other materials (like pictures, music, videos, etc.) will be lost or reformatted during service and MARBL LLC will not be responsible for any such damage or loss.

What this After-Sales Policy Does Not Cover

This policy does not cover the following:

- Damage to equipment caused by improper installation. Read safety warnings on product and manual to protect your safety and warranty.
- Damage caused by unauthorized modification, disassembly, or shell opening not in accordance with official instructions or manuals.
- Water damage or other damages caused by improper installation, incorrect use, or operation not in accordance with official instructions or manuals.
- Damage caused by a non-authorized service provider.
- Damage caused by unauthorized modification of circuits and mismatch or misuse of the battery and charger.
- Damage caused by flights which did not follow instruction manual recommendations.
- Damage caused by operation in bad weather (i.e., strong winds, rain, sand/dust storms, etc.)
- Damage caused by operating the product in an environment with electromagnetic interference (i.e., in mining areas or close to radio transmission towers, high-voltage wires, substations, etc.).
- Damage caused by operating the product in an environment suffering from interference from other wireless devices (i.e., transmitter, video-downlink, Wi-Fi signals, etc.).
- Damage caused by operating the product with weights heavier than specified by instruction manuals.
- Damage caused by a forced operation when unit is displaying abnormal operation characteristics.
- Damage caused by reliability or compatibility issues when using unauthorized third-party parts.
- Damage caused by operating the unit with a low-charged or defective battery.
- Uninterrupted or error-free operation of a product.
- Loss of, or damage to, your data by a product.
- Any software programs, whether provided with the product or installed subsequently.
- Failure of, or damage caused by, any third-party products, including those that MARBL LLC may provide or integrate into the MARBL LLC product at your request.
- Damage resulting from any non-MARBL LLC technical or other support, such as assistance with “how-to” questions or inaccurate product set-up and installation.
- Products or parts with an altered identification label or from which the identification label has been removed.

Limitation of Liability

WHEN RECEIVING SERVICE, MARBL LLC IS RESPONSIBLE FOR LOSS OR DAMAGE TO YOUR PRODUCT ONLY WHILE IT IS IN MARBL LLC'S POSSESSION OR IN TRANSIT, IF MARBL LLC IS RESPONSIBLE FOR TRANSPORTATION.

MARBL LLC IS NOT RESPONSIBLE FOR LOSS OR DISCLOSURE OF ANY DATA, INCLUDING CONFIDENTIAL INFORMATION, PROPRIETARY INFORMATION, OR PERSONAL INFORMATION, CONTAINED IN A PRODUCT. UNDER NO CIRCUMSTANCES, AND NOTWITHSTANDING THE FAILURE OF ESSENTIAL PURPOSE OF ANY REMEDY SET FORTH HEREIN, SHALL MARBL LLC, ITS AFFILIATES, SUPPLIERS, RESELLERS, OR SERVICE PROVIDERS BE LIABLE FOR ANY OF THE FOLLOWING EVEN IF INFORMED OF THEIR POSSIBILITY AND REGARDLESS OF WHETHER THE CLAIM IS BASED IN CONTRACT, WARRANTY, NEGLIGENCE, STRICT LIABILITY OR OTHER THEORY OF LIABILITY: 1) THIRD PARTY CLAIMS AGAINST YOU FOR DAMAGES; 2) LOSS, DAMAGE OR DISCLOSURE OF YOUR DATA; 3) SPECIAL, INCIDENTAL, PUNITIVE, INDIRECT OR CONSEQUENTIAL DAMAGES, INCLUDING BUT NOT LIMITED TO LOST PROFITS, BUSINESS REVENUE, GOODWILL OR ANTICIPATED SAVINGS. IN NO CASE SHALL THE TOTAL LIABILITY OF MARBL LLC, ITS AFFILIATES, SUPPLIERS, RESELLERS, OR SERVICE PROVIDERS FOR DAMAGES FROM ANY CAUSE EXCEED THE AMOUNT OF ACTUAL DIRECT DAMAGES, NOT TO EXCEED THE AMOUNT PAID FOR THE PRODUCT.

THE FOREGOING LIMITATION DOES NOT APPLY TO DAMAGES FOR BODILY INJURY (INCLUDING DEATH), DAMAGE TO REAL PROPERTY OR DAMAGE TO TANGIBLE PERSONAL PROPERTY FOR WHICH MARBL LLC IS LIABLE UNDER LAW.

AS SOME STATES OR JURISDICTIONS DO NOT ALLOW THE EXCLUSION OR LIMITATION OF INCIDENTAL OR CONSEQUENTIAL DAMAGES, THE ABOVE LIMITATION OR EXCLUSION MAY NOT APPLY TO YOU.

Limitation of Warranty

TO THE EXTENT PERMITTED BY LAW, EXCEPT AS EXPRESSLY PROVIDED IN THIS LIMITED WARRANTY, MARBL LLC DISCLAIMS ALL WARRANTIES OF ANY KIND, WHETHER STATUTORY, EXPRESS, OR IMPLIED, INCLUDING: (A) ANY IMPLIED WARRANTY OF MERCHANTABILITY, FITNESS FOR A PARTICULAR PURPOSE, TITLE, QUIET ENJOYMENT, OR NON-INFRINGEMENT; AND (B) ANY WARRANTY ARISING OUT OF COURSE OF DEALING, USAGE, OR TRADE. THE MARBL LLC ENTITIES DO NOT WARRANT, EXCEPT AS EXPRESSLY PROVIDED IN MARBL LLC LIMITED WARRANTY, THAT THE PRODUCT, PRODUCT ACCESSORIES, OR ANY PORTION OF THE PRODUCT, OR ANY MATERIALS, WILL BE UNINTERRUPTED, SECURE, OR FREE OF ERRORS, VIRUSES, OR OTHER HARMFUL COMPONENTS.

SHOULD SUCH WARRANTIES CANNOT BE DISCLAIMED, MARBL LLC LIMITS THE DURATION AND REMEDIES OF SUCH WARRANTIES TO THE DURATION OF THIS EXPRESS WARRANTY AND, AT MARBL LLC'S OPTION, THE REPAIR OR REPLACEMENT SERVICES PROVIDED IN THIS LIMITED WARRANTY.

SOME JURISDICTIONS MAY PROHIBIT A DISCLAIMER OF WARRANTIES AND YOU MAY HAVE OTHER RIGHTS THAT VARY FROM JURISDICTION TO JURISDICTION.

Your other Rights

This Limited Warranty provides you with extra and specific legal rights. You may have other rights according to the applicable laws of your state or jurisdiction. You may also have other rights under a written agreement with MARBL LLC. Nothing in this Limited Warranty affects your statutory rights, including rights of consumers under laws or regulations governing the sale of consumer products that cannot be waived or limited by agreement.

16.2. Part B – Warranty Period of Parts

PRODUCT: ORBIT CAMERA DOLLY SYSTEM

MAIN COMPONENTS	WARRANTY PERIOD
Motor	12 Months
PCB Electronics	90 Days
Visor LED	90 Days
Motor Mount	12 Months
Down Rod	12 Months
Motor Battery	90 Days and less than 100 Cycle Charges
Ring Light LEDs	90 Days
Ring Light Batteries	90 Days and less than 100 Cycle Charges
Remote control	90 Days
Remote Control Battery	No Warranty
Carry Case	No Warranty
Aluminum Hardware Parts	12 Months

Table 3: Warranty Period of Parts

16.3. Part C – Country/Region Specific Terms

MARBL LLC will at its discretion honor product warranties for items purchased for use outside of North America for a period of 90 days from the date of purchase from an authorized reseller or distributor. Repair requests and part replacements can only be performed by an authorized distributor or directly through MARBL LLC USA. The product owner may return the unit back to MARBL LLC for inspection and repair at their cost. Alternatively, MARBL LLC may choose to send repair or replacement part to the customer if the service representative deems that the repair will not require the customer to have significant technical knowledge to repair their product on their own.

International customers can contact MARBL LLC USA at +1.800.451.5569 if they have any questions.

MARBL.

PO BOX 5713

Scottsdale, AZ 85261

+1.800.451.5569

Support@marblorbit.com