



High End Systems Cyberlight LED Automated Luminaire User Manual

Version 1.0.5

Part Number: 2597M1200-1.0.5 Rev: B

Released: 2025-01

To view a list of ETC trademarks and patents, go to etconnect.com/ip. All other trademarks, both marked and not marked, are the property of their respective owners.

You can find complete High End Systems terms and conditions and warranty information at etconnect.com/Support/Warranty.aspx.

For a complete list of all third-party licenses that are fully incorporated herein to the extent required by each third-party license terms and conditions, please visit etconnect.com/licenses.

Some software features may not be available depending on your product configuration or region.

The images provided in this document are for illustrative purposes only. Depending on the product details and market region, the information in this document may appear slightly different from your product.

ETC intends this document, whether printed or electronic, to be provided in its entirety.

Table of Contents

Introduction	6
Document Conventions	6
Help from Technical Services	7
Safety Considerations	8
General Operation and Use Guidelines	10
Unpack the Fixture	11
Remove the Yoke	11
Fixture Overview	12
Yoke Assembly	13
Specifications	13
Environment	13
Power	14
Electrical Specifications	14
Input and Power Factor	14
Fixtures per Circuit	14
Connector Specifications	14
Fixture Installation Hardware	15
Install the Yoke	15
Install the Fixture	17
DMX Control	19
DMX Connector Pinout	19

Connect DMX Cables to Fixture	19
Terminate DMX	20
Set the DMX Start Address	20
DMX Channels	20
Ethernet Control	21
Connect Ethernet Cables to a Fixture	21
Ethernet Control and DMX Thru	22
Terminate DMX	22
Set the DMX Start Address	22
Configure the Fixture	23
Navigate the User Interface	23
DMX Address	24
Settings Menu	24
Set the Control Options	24
Set the Network Options	25
Set the Pan/Tilt Options	26
Set the Dimming Options	26
Set the Fan Options	26
Set the Display Options	27
Software Update	27
Calibration Options	28
Restore Defaults	28
Home/Test Menu	28
Home Options	28
Test Options	29
Diagnostics Menu	29
Set Time Options	29
View Errors	29
View Fan RPM	29
View Sensors	30
View Temperatures	30
View DMX Monitor	30
View Software Version	30

View Device	30
Change the Offset of the Mirror Head	31
Replace a Gobo	32
Considerations for Custom Gobos	32
Remove the Effects Module	32
Replace a Gobo	34
Install the Effects Module	38
Replace Color Media	39
Remove the Color Module	39
Replace Color Media	40
Install the Color Module	41
Install the Snoot Accessory	42
Error Codes	43
Maintenance	47
Clean Fans and Dust Filters	47
Clean the Mirror	48
Replace the Fuse	48
Compliance	49
FCC Compliance	49

Introduction

This manual provides important information for the safe installation, configuration, and maintenance of your High End Systems Cyberlight LED fixture. For your safety, read this entire manual prior to installing, operating, or servicing the fixture.

ETC recommends that you update your fixture with the latest version of software before you use the fixture. Software is available for free download from the ETC website: etconnect.com/Products/Automated-Fixtures.

- See [View Software Version on page 30](#) to determine which version of software is currently installed on your fixture.
- See [Software Update on page 27](#) for instructions about updating your fixture.

Document Conventions

This document uses the following conventions to draw your attention to important information.



Note: *Notes are helpful hints and information that is supplemental to the main text.*



CAUTION: *A Caution statement indicates situations where there may be unwanted consequences of an action, potential for data loss, or an equipment problem.*



CAUTION: *Hot Surfaces. This statement indicates that while operating, equipment surfaces may reach very high temperatures. Allow the fixture to cool before handling or servicing.*



WARNING: *A Warning statement indicates situations where damage may occur, people may be harmed, or there are serious or dangerous consequences of an action.*



WARNING: RISK OF ELECTRIC SHOCK! *This warning statement indicates situations where there is a risk of electric shock.*

All ETC High End Systems documents are available for free download from our website: etconnect.com/Products/Automated-Fixtures.

Please email comments about this manual to: TechComm@etconnect.com.

Help from Technical Services

If you have questions that are not answered by this document, try the ETC support website at support.etconnect.com or the ETC LED Automated Lighting product website at etconnect.com/Products/Automated-Fixtures. If none of these resources are sufficient, visit etconnect.com/contactETC and contact ETC Technical Services. Emergency service is available from all ETC offices outside of normal business hours.

When calling for help, take these steps first:





- Prepare a detailed description of the problem
- Go near the equipment for troubleshooting
- Find your notification number if you have called in previously

Safety Considerations

To ensure safe operation, follow the safety instructions and warning notes in the user manual.

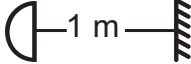
- This fixture is intended for professional use only. Not for residential use. Read the entire manual before using this equipment.
- Contact your authorized ETC dealer or Technical Services before performing any service in order to maintain warranty coverage.

Symbols used on the product label are defined below:

	The luminaire must be installed at least 1.0 m (3 ft 4 in) away from all lighted objects.	Le luminaire doit être installé à au moins 1,0 m (3 pi. 4 po.) de tout objet éclairé.
	General warning	Avertissement général
	Do not stare at the operating light source.	Ne pas regarder la source de lumière lorsqu'elle fonctionne.
	This product should not be discarded as unsorted waste but must be sent to separate collection facilities for recovery and recycling.	Ce produit ne doit pas être jeté avec les déchets ménagers mais doit être déposé dans une collecte de déchets électroniques ou dans un point de collecte.
t_a or T_a	Rated maximum ambient temperature	Température ambiante maximale recommandée
	Operate indoors only, not where this product would be exposed to the weather.	Ne fonctionne qu'à l'intérieur, pas là où ce produit serait exposé aux intempéries.



WARNING: Note the following safety warnings before use:

- **This equipment is designed for operation by qualified personnel only.**
- **Do not stare at the operating lamp. May be harmful to the eyes.**
- **Replace fuses with the specified type and rating only. See [page 48](#).**
- **Ensure that the available voltage is within the stated range. See [page 14](#).**
- **Do not use this fixture with a damaged power lead (cord set). If the lead is damaged, it must be replaced by a qualified technician with an equivalent type before use. Contact your local authorized dealer for replacement power leads.**
- **The fixture should be positioned so that prolonged staring into the fixture at a distance closer than 6.4 m (21 ft) is not expected.**
- **Do not mount the fixture on or near flammable surfaces.**
- **Minimum distance from fixture head to combustible materials: 0.1 m (4 in).**
- **Minimum distance to lighted objects: 1.0 m (3 ft 4 in).**



AVERTISSEMENT : Pour votre sécurité, lisez les mises en garde et les avis suivants avant toute utilisation :

- Cet équipement est conçu pour être utilisé par un personnel qualifié uniquement.
- Ne regardez pas la lampe en fonctionnement. Peut être nocif pour les yeux.
- Remplacez les fusibles uniquement par le type et le calibre indiqués. Voir [page 48](#).
- Veillez à ce que la tension disponible soit dans la plage indiquée. Voir [page 14](#).
- N'utilisez pas ce projecteur avec un cordon d'alimentation endommagé (fils électriques). Si le cordon est endommagé, un technicien qualifié doit le remplacer par un cordon de type équivalent avant que l'appareil ne puisse être utilisé. Contactez votre distributeur agréé local pour obtenir des cordons d'alimentation de rechange.
- L'appareil doit être positionné de manière à ce qu'un regard prolongé dans l'appareil à une distance inférieure à 6,4 m (21 pi) soit peu probable.
- Ne pas installer le projecteur sur ou à côté d'une surface inflammable.
- Distance minimum entre la tête du luminaire et les matériaux combustibles : 0.1 m (4 in).
- Distance minimum avec les objets éclairés : 1.0 m (3 ft 4 in).



WARNING: RISK OF ELECTRIC SHOCK!

- Do not operate this device with the cover open.
- Disconnect the fixture from power and DMX and allow it to cool before performing any cleaning and maintenance.

AVERTISSEMENT : RISQUE DE CHOC ÉLECTRIQUE!

- N'utilisez pas cet appareil avec le couvercle ouvert.
- Débrancher la lampe de son alimentation et du DMX et la laisser refroidir avant d'effectuer un nettoyage ou un entretien.



CAUTION: Hot Surfaces. Allow the device to cool completely before handling and servicing.



ATTENTION : Surfaces chaudes. Laissez le luminaire refroidir complètement avant de le manipuler et de procéder à son entretien.



Note: *The light source in this luminaire is not user-replaceable, and must be replaced only by a qualified technician. Contact ETC Customer Support for assistance.*

General Operation and Use Guidelines

- This fixture is only allowed to be operated with the maximum alternating current that is stated in the technical specifications label provided on the fixture.
- Lighting effects are not designed for permanent operation. Consistent operation breaks may extend the life of the fixture.
- When choosing the installation location, make sure the fixture will not be exposed to extreme heat, moisture, or dust.
- Do not point the mirror toward the sun or other bright light source. Doing so could damage the fixture.
- Operate the fixture only after having familiarized yourself with its functions. Do not permit persons who are not qualified and familiar with its functions to operate the fixture.
- Do not modify the fixture. Any modifications will void the warranty.
- This manual describes the proper installation and operation of this fixture. Using this fixture in any way other than the intended use may cause damage and void the warranty.
- When the fixture has been stored or transported in cold temperatures, allow it to warm to room temperature for a minimum of one hour before applying power. Applying power to a cold fixture may cause damage to the fixture and void the manufacturer warranty.
- Please use the original packaging if the fixture is to be transported. ETC will not be responsible for the fixture if packaging other than manufacturer provided packaging is used.

Unpack the Fixture

The Cyberlight LED shipping carton includes:

- one (1) Cyberlight LED automated luminaire
- one (1) power cord (powerCON TRUE1 TOP input to bare ends)
- one (1) yoke with yoke installation hardware (the luminaire ships with the yoke attached)
- one (1) stainless steel safety cable with locking carabiner

Visually inspect the shipping carton for damage that may have occurred during transit. If the shipping carton shows signs of damage, document the damage fully before unpacking the contents. Documentation of any damage is helpful when reporting a claim with the carrier.

The luminaire weighs approximately 38 kg (84 lb). For your safety, ETC recommends that two people unpack the luminaire from the shipping carton. Use the handles on the sides of the luminaire to lift the luminaire from the shipping carton.

Do not discard the shipping carton and packaging materials. The carton and packing materials are specifically designed to protect the fixture during transport and will be useful if you need to ship the fixture, including transporting the fixture for service.

Remove the Yoke

The Cyberlight LED ships with the yoke installed in a shipping configuration to help protect the fixture from damage during transit. Remove the yoke from the fixture after you unpack the fixture. See [Yoke Assembly on page 13](#) for information about the components of the yoke.

Tool needed:

- 8.0 mm hex key
1. Loosen but do not remove the yoke locking knobs on each side of the yoke.
 2. Using the 8.0 mm hex key, remove the yoke pivot screws and washers from each side of the yoke.
Save the screws and washers. You will need them when you attach the yoke to the fixture in its operating configuration.

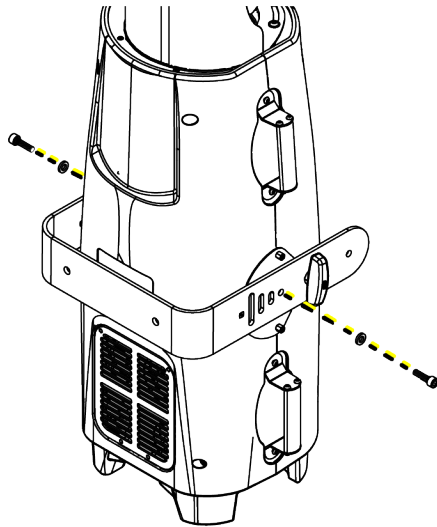

3. Lift the yoke from the fixture.

Fixture Overview

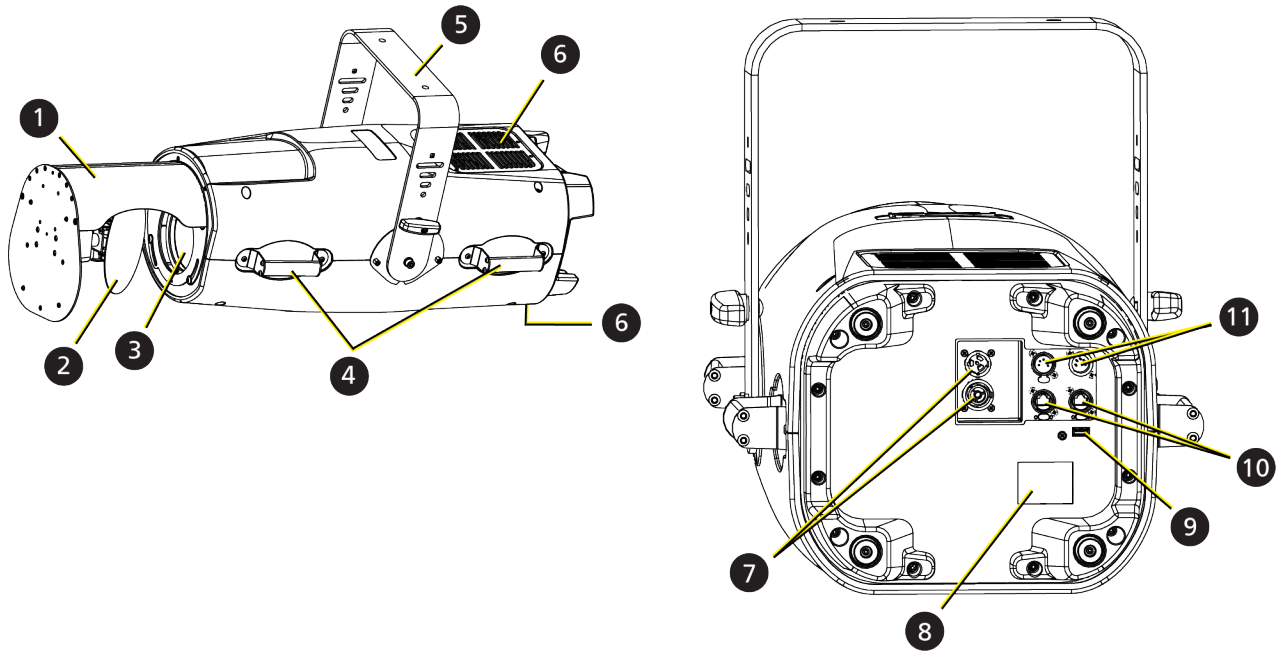

Item	Description
1	Mirror head
2	Mirror
3	Output window
4	Handles
5	Adjustable yoke (see Yoke Assembly on page 13 for details)
6	Fans and dust filter
7	powerCON TRUE TOP power input and thru connectors
8	Display and navigation controls
9	USB port
10	Ethernet ports (x2)
11	DMX In and DMX Thru connectors

Yoke Assembly

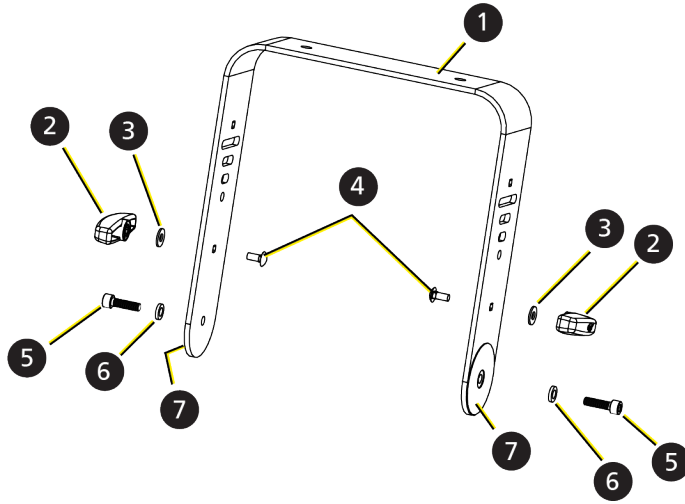

Item	Description	Quantity
1	Yoke	1
2	Yoke locking knob	2
3	8 mm (5/16 in) flat washer	2
4	8 mm (5/16 in) carriage bolt	2
5	Yoke pivot screw (M10x35 mm)	2
6	Washer	2
7	Degree label	2

Specifications

For complete technical specifications, see the technical datasheet:
etconnect.com/Products/High-End-Systems/Lighting-Fixtures/Cyberlight/Documentation.aspx.

Environment

- Ambient operating temperature range: -10°C to 40°C (14°F to 104°F).
- Relative humidity: 0%–90%, non-condensing.
- Storage temperature: -20°C to 60°C (-4°F to 140°F).
- Indoor use only.
- Dry locations only, IP20 rated.

Power



WARNING: Connect the fixture to a non-dimmable power source in order to avoid damage to the fixture's internal power supply and other electrical components. Using a dimmable power source can damage the fixture and will void the warranty.

Electrical Specifications

- 100–240 VAC at 50/60 Hz
- Maximum power consumption: 700 W

Input and Power Factor

The values listed below were measured with LEDs at full and all motors functioning.

VAC	Amps	Hz	Watts	VA	PF
100	7.0	50	694	697	0.99
120	5.7	60	681	687	0.99
200	3.3	50	661	666	0.99
208	3.2	60	661	666	0.99
220	3.0	50	661	669	0.99
230	2.9	50	656	661	0.99
240	2.8	60	659	667	0.98

Fixtures per Circuit

One fixture can be linked via the power thru connector (2 fixtures total per circuit).

The fixtures per circuit information assumes the use of an ETC R20 breaker module. Consult the upstream breaker trip curves when using other equipment.

Connector Specifications



WARNING: Risk of Shock and Fire. Assemble a grounding-type attachment plug with integral cord grip that is within the voltage and amperage rating of this luminaire.

AVERTISSEMENT : Risque de choc et d'incendie. Assurez-vous d'utiliser une prise de mise à la terre avec décharge de traction intégrée qui respecte la tension et l'ampérage de ce luminaire.

A power input cable with powerCON® TRUE1® TOP input to bare ends is provided. The power input cable is rated for maximum 20 A (120 VAC/60 Hz) and 16 A (240 VAC/50 Hz). Install a suitable connector to meet the installation requirements. See the following wire color code chart:

Wire Color Code (EU)	Wire Color Code (US Standard)	Connection type	Terminal
Green/Yellow	Green	Earth/Ground	
Blue	White	Neutral	N
Brown	Black	Line (Live)	L

Fixture Installation Hardware

The top of the yoke has two 13 mm (1/2 in) diameter mounting holes for attaching installation hardware. Installation hardware is not provided with the Cyberlight LED fixture. Select appropriately sized hardware for your installation.

The installation hardware you choose must be capable of supporting, at a minimum, the weight of the fixture (38 kg [84 lb]) and the associated cables.

Install the Yoke

The Cyberlight LED fixture yoke can be installed in two configurations:

- The standard yoke installation is shown in (a) below.
 - The yoke pivot screws and washers are installed in the screw hole at the end of each yoke arm.
 - The yoke locking knobs are installed in the star-shaped hole nearest the end of the each yoke arm.
- The optional installation (shown in (b) below) lets you suspend the fixture closer to the installation point.
 - The yoke pivot screws and washers are installed in the screw hole in the center of each yoke arm.
 - The yoke locking knobs are installed in the star-shaped hole nearest the top of the yoke.

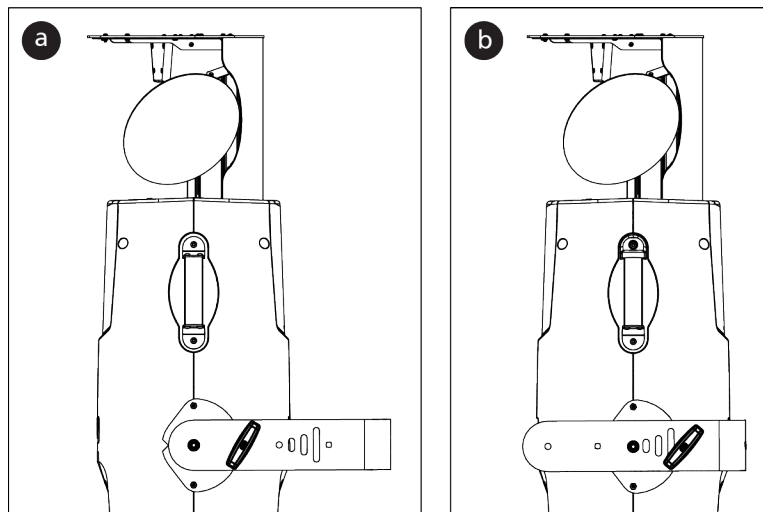

Note: Due to limited space between the yoke and the fixture when the yoke is installed in the optional configuration (b), ETC recommends that you attach the installation hardware to the yoke before you attach the yoke to the fixture.

See [Yoke Assembly on page 13](#) for details about the yoke and its hardware.

Tool needed:

- 8.0 mm hex key
1. Insert the 8 mm (5/16 in) carriage bolts through the appropriate star-shaped holes in the yoke, and attach the 8 mm (5/16 in) flat washers and yoke locking knobs to the bolts. Do not tighten the knobs at this time; you will adjust them later.
 2. Position the yoke on the fixture.
 - a. Make sure the U-shape of the yoke is located on the same side of the fixture as the back side of the mirror head.
 - b. Align the appropriate screw holes in the yoke with the screw holes on the sides of the fixture.
 3. Using the 8.0 mm hex key, attach the washers and yoke pivot screws to each side of the yoke. Tighten the screws until the screws are securely fastened but you are still able to pivot the yoke.
 4. Rotate the yoke to the desired position. Use the markings on the degree label for precise positioning.
 5. Firmly tighten the yoke locking knobs to secure the yoke in place.
 6. Firmly tighten the yoke pivot screws.

Install the Fixture

Overhead rigging must be performed by qualified personnel. Follow all local and national codes and recommended practices.



WARNING:

- The installation location must support a minimum point load of 6 times the weight of the fixture. Fixture weight is 37.6 kg (83.0 lb).
 - The installation must always be secured with a secondary safety attachment. An appropriate safety cable is supplied.
 - Safety cable attachment must be rated by a safety factor of 6.
 - A supportive and stable surface must be used when the fixtures are placed on the feet.
 - Never stand directly below the installed fixture when mounting, removing, or servicing the fixture.
 - All safety and technical aspects of fixture installation must be approved by a qualified personnel before operation.
 - The installation must be regularly inspected by qualified personnel.
-



AVERTISSEMENT :

- L'emplacement d'installation doit supporter une charge concentrée minimale de 6 fois le poids de l'appareil. Le poids du projecteur est de 37.6 kg (83.0 lb).
 - L'installation doit toujours être sécurisée par une fixation de sécurité auxiliaire. Un câble de sécurité approprié est fourni.
 - La fixation du câble de sécurité doit être classée avec un facteur de sécurité de 6.
 - Une surface d'appui stable doit être utilisée quand les projecteurs sont placés sur pieds.
 - Ne vous placez jamais directement sous le projecteur lors du montage, du démontage ou de son entretien.
 - Tous les aspects techniques et de sécurité de l'installation du projecteur doivent être approuvés par un personnel qualifié avant qu'il ne soit utilisé.
 - L'installation doit être régulièrement inspectée par du personnel qualifié.
-

You can install the fixture in any of the orientations shown below. ETC recommends that you use three people to install each Cyberlight LED fixture: two people to hold the fixture while the third person secures the fixture to the installation location.

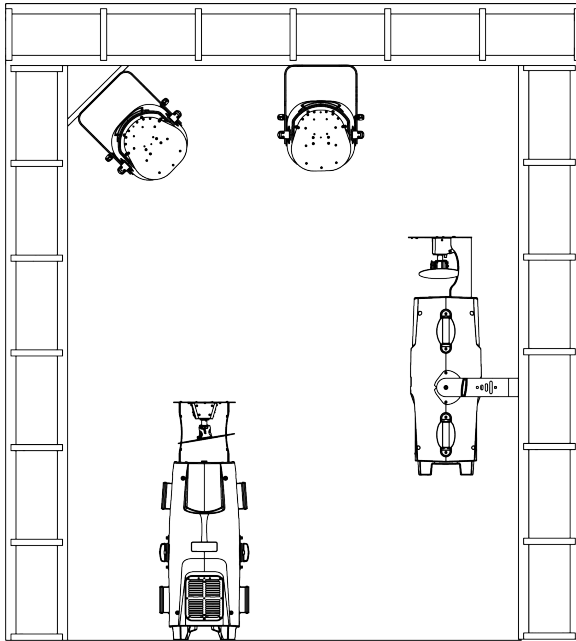

1. If you have not already done so, attach the installation hardware to the top of the yoke following the hardware manufacturer's assembly instructions.
2. Attach the fixture to the installation location following the installation hardware manufacturer's instructions for a secure fit.
3. Loop the provided safety cable around the top of the yoke and secure it to the trussing system or other safe installation point. Follow local codes and recommended safety standards for securing the fixture to the installation location.
4. Apply power to the fixture.
5. Inspect the installation prior to lifting the fixture overhead.

DMX Control

The Cyberlight LED fixture operates on standard DMX512 control bus, controlled by a DMX console. The fixture requires 40 channels of DMX.

Attach the fixture to the control bus using a two-core, shielded cable with a 5-pin XLR connector (Belden 9729 is preferred). DMX512 connections must be Class 2.

The fixture includes two 5-pin XLR connectors, one for DMX Input and one for DMX Thru (for use when daisy-chaining fixtures on the DMX control bus).

DMX Connector Pinout

Use the following standard pinout when preparing DMX cable with 5-pin XLR connectors. ETC recommends using Belden 9729 or equivalent cable. (See the ETC cable cross database for equivalent alternatives: etcconnect.com/cablecross.) The second data pair in the recommended cable type is not used, but is reserved for future service.

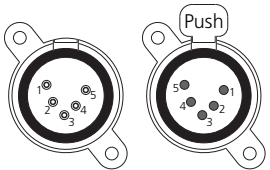
DMX Pinout for Five-Pin XLR	Pin	Use
	1	Common (shield)
	2	Data -
	3	Data +
	4	Not connected
	5	Not connected

Connect DMX Cables to Fixture

The following instructions are guidelines for connecting DMX to your fixture. Your installation may vary.

1. Connect a DMX data cable to the DMX control source and the DMX In XLR receptacle on the first fixture in the DMX data run.
2. Link the remaining fixtures in the data run by connecting a DMX data cable from the DMX Thru connector on a fixture to the DMX In connector on the next fixture in the data run.



Note: To ensure that cumulative leakage current on control wiring does not exceed 3.5 mA, connect no more than 32 DMX devices on a single DMX data run.

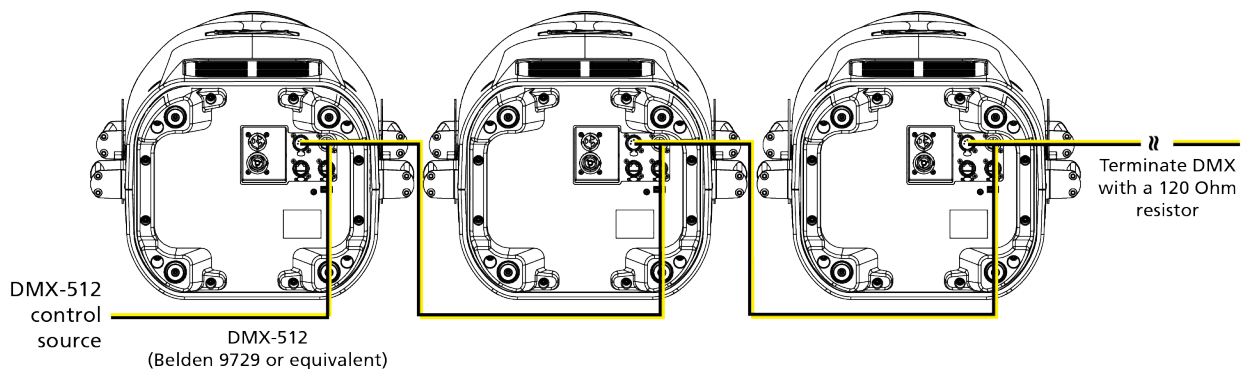

Terminate DMX

Use a DMX terminator or install a resistor on the last fixture of the DMX control run to prevent corruption (data reflection) of the digital control signal by electrical noise.

A DMX terminator is an XLR plug with a 120 Ω resistor connected between pins 2 and 3 that can be installed into the DMX output receptacle of the last fixture in the DMX control run. Contact your authorized dealer or ETC for ordering information (etcconnect.com/contactETC), or purchase an XLR DMX terminator from the ETC Online Shop (shop.etcconnect.com).

Set the DMX Start Address

Give each fixture a unique DMX starting address so that the correct fixture responds to the control signals. This DMX start address is the channel number from which the fixture starts to “listen” to the digital control information sent out from the control source.

Modify the DMX start address on the user interface, which is located on the rear of the fixture. See [DMX Address on page 24](#).



Example: *The Cyberlight LED requires 40 channels of control. If you set the DMX starting address of the first fixture to 1, you could set the second fixture to 41 (40+1), the third to 81 (40+41), and so on.*

DMX Channels

The current DMX channel map for the Cyberlight LED can be found on the ETC website: etcconnect.com/Products/High-End-Systems/Lighting-Fixtures/Cyberlight/Documentation.aspx.

Ethernet Control

The Cyberlight LED fixture includes two Ethernet ports that allow sending and receiving of control signals using the Art-Net protocol or sACN.

Use a Cat5e (or better) cable and terminate to RJ45 connectors following the TIA/EIA 568B wiring standard.

Connect Ethernet Cables to a Fixture

The following instructions are guidelines for connecting Ethernet to your fixture. Your installation may vary.

1. Connect a cable from the Ethernet control source to one of the Ethernet ports on the first fixture in the Ethernet control run.
2. Connect the first fixture to a second fixture by connecting a cable from the second Ethernet port on the first fixture to one of the Ethernet ports on the second fixture.
3. Continue linking the remaining fixtures by connecting a cable from Ethernet port to Ethernet port on the fixtures on the control run.



Note: *The Cat5e cable distance should not exceed 100 m (328 ft), and you should not connect more than 20 fixtures in one Ethernet control run.*

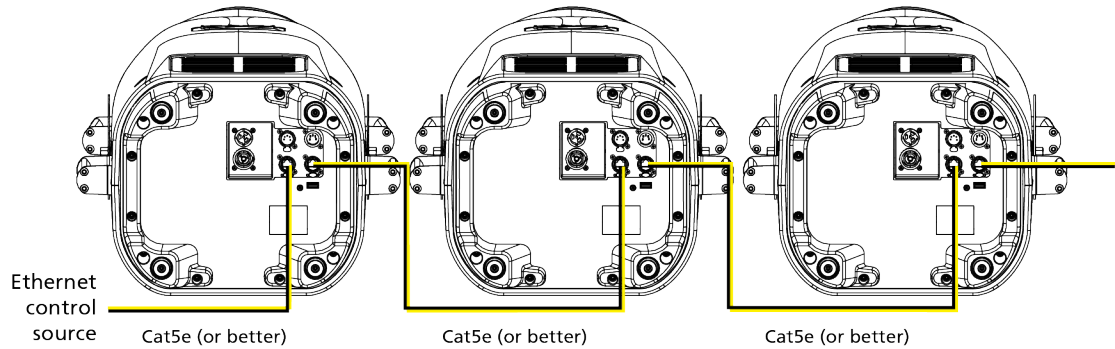

Ethernet Control and DMX Thru

You can use Ethernet control and DMX Thru. When a fixture is set up to receive Ethernet control input using the Art-Net protocol, it automatically distributes DMX via the DMX Thru port. The DMX signal is sent as a single universe that corresponds to the universe of the fixture that is receiving Ethernet control.

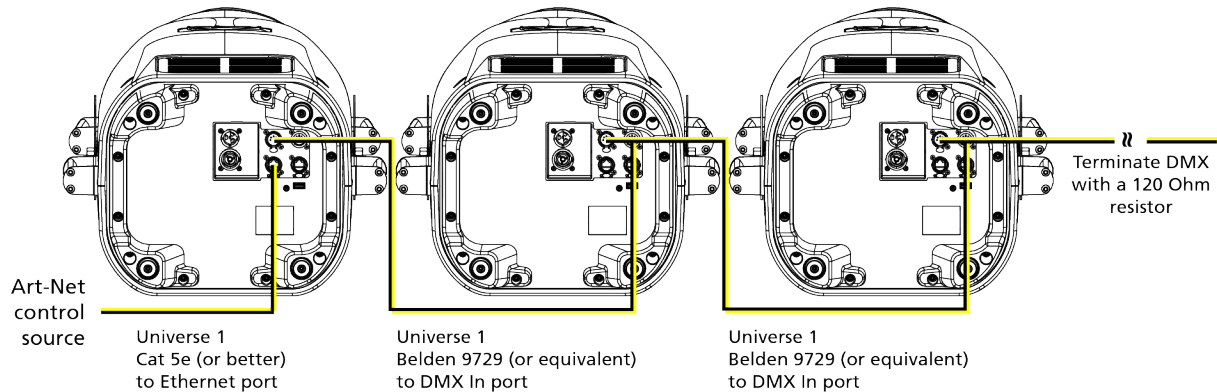

Terminate DMX

Use a DMX terminator or install a resistor on the last fixture of the DMX control run to prevent corruption (data reflection) of the digital control signal by electrical noise.

A DMX terminator is an XLR plug with a 120 Ω resistor connected between pins 2 and 3 that can be installed into the DMX output receptacle of the last fixture in the DMX control run. Contact your authorized dealer or ETC for ordering information (etconnect.com/contactETC), or purchase an XLR DMX terminator from the ETC Online Shop (shop.etconnect.com).

Set the DMX Start Address

Give each fixture a unique DMX starting address so that the correct fixture responds to the control signals. This DMX start address is the channel number from which the fixture starts to “listen” to the digital control information sent out from the control source.

Modify the DMX start address on the user interface, which is located on the rear of the fixture. See [DMX Address on page 24](#).



Example: *The Cyberlight LED requires 40 channels of control. If you set the DMX starting address of the first fixture to 1, you could set the second fixture to 41 (40+1), the third to 81 (40+41), and so on.*





Configure the Fixture

You can configure the Cyberlight LED fixture through the onboard user interface.

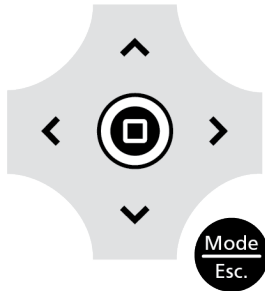
Connect the fixture to power before you configure it. If you do not provide power, the fixture will use battery power to power the user interface.

Navigate the User Interface



1. Press the [MODE/ESC] button  to access the main menu. (The display is powered by battery when the fixture has no power; press and hold the [MODE/ESC] button  to access the main menu.)
2. Browse the menu by pressing the up, down, left, or right navigation buttons.
3. Press the Enter button  to select a menu item.
4. Modify the selection by pressing the up, down, left, or right navigation buttons according to the selection.
5. Press the Enter button  to confirm a modified selection.
6. To exit the menu or selection, press the [MODE/ESC]  button.

DMX Address

Navigate: Main Menu → DMX Address

Set the DMX address for the fixture. The default value is 001.

Settings Menu

Navigate: Main Menu → Settings

The Settings menu provides access to configure and set up the Cyberlight LED.

Provide power to the fixture before configuring it. If you do not provide power, the fixture will use battery power to power the user interface.

Set the Control Options

Navigate: Main Menu → Settings → Control

Parameter	Value	Description
DMX Mode	Standard (40)	Sets the DMX control mode.
Data Loss	<ul style="list-style-type: none">• Hold Last Look• Wait and Fade	Sets the control mode when DMX is not connected. The default setting is Hold Last Look.
Protocol	<ul style="list-style-type: none">• DMX• sACN• Art-Net	Sets the control mode. The default setting is DMX. When Art-Net or sACN is selected, additional properties are required in the Settings → Network menu.

Set the Network Options



Note: The Network menu is hidden when the Control Protocol setting is DMX.

Navigate: Main Menu → Settings → Network

Parameter	Value	Description
Universe	When sACN is the selected Protocol , set a value of 1-255. When Art-Net is the selected Protocol , set a value of 0-255.	Sets the universe. The default setting for sACN is 1. The default setting for Art-Net is 0.
IP Address	When sACN is the selected Protocol , the IP address format is 192.XXX.XXX.XXX When Art-Net is the selected Protocol , the IP address format is 010.XXX.XXX.XXX	Sets the IP address. Use the left (<) and right (>) navigation buttons to select the section of the IP address that you need to change. Use the up and down navigation buttons to change the selected value. Note: If IP Mode is set to DHCP , the IP address is assigned by the DHCP server and you cannot change it. The phrase "Waiting Address" appears below the IP address when the fixture is waiting for an IP address from the DHCP server. If the DHCP server times out, "Timeout Default" appears below the IP address and the fixture uses the last assigned IP address.
Net (shown when Art-Net is the selected Protocol)	The default is 000.	Sets the net value. Use the up and down navigation buttons to change the selected value.
Subnet Mask (shown when sACN is the selected Protocol)	The subnet mask IP address format is 255.XXX.XXX.XXX.	Sets the subnet mask IP address for the sACN protocol. Use the left (<) and right (>) navigation buttons to select the section of the IP address that you need to change. Use the up and down navigation buttons to change the selected value. Note: If IP Mode is set to DHCP , the subnet mask IP address is assigned by the DHCP server and you cannot change it.
IP Mode (shown when sACN is the selected Protocol)	<ul style="list-style-type: none"> • Static IP • DHCP 	Sets the IP mode.

Set the Pan/Tilt Options

Navigate: Main Menu → Settings → Pan/Tilt

Parameter	Value	Description
Pan Invert	<ul style="list-style-type: none">• Off• On	When set to On, inverts pan movement of the mirror to the opposite direction. The default setting is Off.
Tilt Invert	<ul style="list-style-type: none">• Off• On	When set to On, inverts tilt movement of the mirror to the opposite direction. The default setting is Off.
Pan/Tilt Swap	<ul style="list-style-type: none">• Off• On	When set to On, pan responds to the tilt channels and tilt responds to the pan channels. The default setting is Off.
Pan/Tilt Encoders	<ul style="list-style-type: none">• Off• On	When set to On, the pan and tilt encoders correct the mirror position when the mirror is moved manually outside of control. You may want to turn Pan/Tilt Encoders to the Off setting when working on a fixture so that you can move the pan and tilt without correction. The default setting is On.
Pan/Tilt Speed	<ul style="list-style-type: none">• Refined• Fast	Set the speed mode for mirror movement. Refined provides smooth movement of the mirror. Fast provides increased acceleration and speed, but movement is less smooth than Refined. The default setting is Refined.

Set the Dimming Options

Navigate: Main Menu → Settings → Dimming Frequency

Set the dimming curve and pulse width modulation (PWM) frequency. The default value is 17.6 kHz.

- **17.6 kHz** - quieter than 2.2 kHz and creates a beam that does not flicker when shown on camera
- **2.2 kHz** - prioritizes flawless, stepless dimming

Set the Fan Options

Navigate: Main Menu → Settings → Fan

Select the fan mode for the fixture. The default setting is Auto.

- **Auto**
- **Studio** - reduces fan noise, but decreases fixture output by ~20%

Set the Display Options

Navigate: Main Menu → Settings → Display

Parameter	Value	Description
Timeout	<ul style="list-style-type: none">• Always On• 30s Delay	Set the display timeout. The default setting is 30s Delay which turns the display back light off after 30 seconds of inactivity.
Flip	<ul style="list-style-type: none">• Automatic• Flip	Set the display orientation. When set to Automatic, the accelerometer in the fixture determines the orientation. Use the Flip menu option to manually override the current orientation, flipping the current state 180°. The default setting is Automatic.
Brightness	1-100 (full)	Set the display back light brightness. The default setting is 100.

Software Update

Navigate: Main Menu → Settings → Software Update

Displays the software update options for the Cyberlight LED.

USB Update



CAUTION: *Do not remove the USB drive from the fixture until the update procedure is finished and the fixture display returns to its default state.*

Navigate: Main Menu → Settings → Software Update → USB Update

Software updates for the Cyberlight LED fixture are available on the ETC website at etcconnect.com/Products/Automated-Fixtures.

1. Download the software zip file from the ETC website.
2. Unzip the contents of the zip file.
3. Save the software update file (.upl) to the root directory of a FAT32-formatted USB drive.
4. Insert the USB drive in the USB port on the rear of the fixture.
5. In the main menu, select **Settings → Software Update → USB Update**. The fixture reads the USB drive and displays the version of software that is currently installed on the fixture and the version of the software contained on the USB drive.
6. Press the Enter button to begin the update process.
7. Press the Enter button a second time. The software update begins.
 - The display provides information about the progress of the update.
 - The fixture restarts when the update is complete, and the display returns to its default state.
8. Remove the USB drive from the fixture when the fixture restart is complete.

Crossload

Navigate: Main Menu → Settings → Software Update → Crossload

Load software from one fixture to another over the DMX cable.



Note: *Fixtures cannot be updated using the Crossload option if an sACN or Art-Net signal is present.*

1. If necessary, follow the instructions in [USB Update on page 27](#) to install the new software version on the host fixture (the fixture from which you will initiate the software update to the remaining fixtures on the data run).
2. Disconnect the DMX control source from the host fixture's DMX IN port.
3. In the main menu on the host fixture, select **Settings** → **Software Update** → **Crossload**.
4. Press the Enter button to initiate the update process. The software update begins.
 - The display provides information about the progress of the update.
 - Each fixture restarts when the update is complete, and the display returns to its default state.
5. When all of the Cyberlight LED fixtures on the data run have been updated to the new software version, reconnect the DMX control source to the host fixture's DMX IN port.

Calibration Options

Navigate: Main Menu → Settings → Calibration

This menu is passcode protected and reserved for authorized technician use only. Contact ETC Technical Support for assistance.

Restore Defaults

Navigate: Main Menu → Settings → Restore Defaults

Selecting **Yes** and confirming this option restores the fixture to its factory default settings.

Home/Test Menu

Navigate: Main Menu → Home/Test

The Home/Test menu contains options to rehome the fixture and test the fixture's mechanical features and attributes.

The fixture must be powered prior to rehoming or testing features and attributes. If you do not provide power, the fixture will use battery power to power only the user interface.

Home Options

Navigate: Main Menu → Home/Test → Home

Home (reset) the selected features:

- **All** - homes all mechanical features of the fixture including pan, tilt, color, gobo wheels, diffusion, and lenses
- **Pan/Tilt** - homes the pan and tilt
- **Colors** - homes the color wheel
- **Apertures** - homes the gobo wheels
- **Effects** - homes the primary (radial) diffuser and the prism
- **Lenses** - homes the optics system

Test Options

Navigate: Main Menu → Home/Test → Test

Run a self-test program on features and attributes of the Cyberlight LED fixture. When you run the test, the display indicates "Running" and the fixture automatically runs a self-test procedure, testing each of the functions. Press [MODE/ESC] button to end the self-test and return the display to the previous menu.

- **All** - runs a self-test on all mechanical features of the fixture including pan, tilt, color, gobo wheels, diffusion, and lenses
- **Pan/Tilt** - runs a self-test on the pan and tilt
- **Color** - runs a self-test on the color wheel
- **Apertures** - runs a self-test on the gobo wheels
- **Effects** - runs a self-test on the primary (radial) diffuser and the prism
- **Lenses** - runs a self-test on the optics system
- **Light Engine** - runs a self-test on the light engine

Diagnostics Menu

Navigate: Main Menu → Diagnostics

Set Time Options

Navigate: Main Menu → Diagnostics → Time

Parameter	Value	Description
Total Fixture Hours	Read only value in hours	Total run time of the fixture, shown in hours (h). The counter cannot be reset by the user.
Fixture Hours	Read only value in hours	Run time of the fixture since the last reset, shown in hours (h). The counter is reset only from the Reset option, which is passcode protected.
Total LED Hours	Read only value in hours	Total run time of the LED engine, shown in hours (h). The counter cannot be reset by the user.
LED Hours	Read only value in hours	Run time of the LED engine since the last reset, shown in hours (h). The counter is reset only from the Reset option, which is passcode protected.
Reset	Enter Passcode	This protected menu provides access to reset Fixture and LED hours. As needed, contact Technical Support at ETC for access. See Help from Technical Services on page 7 .

View Errors

Navigate: Main Menu → Diagnostics → Errors

Errors that are present in the fixture are shown. Errors will automatically clear from the list as they are mitigated. See [Error Codes on page 43](#) for information about the errors.

View Fan RPM

Navigate: Main Menu → Diagnostics → Fan RPM

Displays the speeds (in rotations per minute) of the fixture's fans.

View Sensors

Navigate: Main Menu → Diagnostics → Sensors

Displays the status of sensors, which can help you to determine whether the fixture is recognizing movement and position of the fixture attribute. Attributes that report sensor status include pan, tilt, color, gobos, and zoom/focus. The status of the sensor is shown as a green or red icon that toggles as the magnet passes the sensor.

View Temperatures

Navigate: Main Menu → Diagnostics → Temperatures

Displays the current measured temperature for the LED engine, display, motor driver board, and LED driver board.

View DMX Monitor

Navigate: Main Menu → Diagnostics → DMX Monitor

Displays the current DMX value for each of the fixture's channels (parameters of the fixture). Scroll the list to view all available parameters. DMX data is not available when DMX is not connected.

View Software Version

Navigate: Main Menu → Diagnostics → Software Version

Displays the software version that is currently installed on the fixture.

View Device

Navigate: Main Menu → Diagnostics → Device

Displays the fixture's RDM and IP address information (read only).

- **RDM Device Label** - a compatible RDM controller can read and write the device label
- **RDM Device ID** - a unique device ID
- **IP Address** - an Ethernet IP address assigned in the **Settings** → **Network** → **Set IP Address** menu.

Change the Offset of the Mirror Head

You can offset the mirror head up to 20 degrees left or right of center for a total range of 40 degrees.

Tool required:

- 5.0 mm hex key

1. Loosen (but do not remove) the thumb screw and four hex screws located at the base of the mirror head.

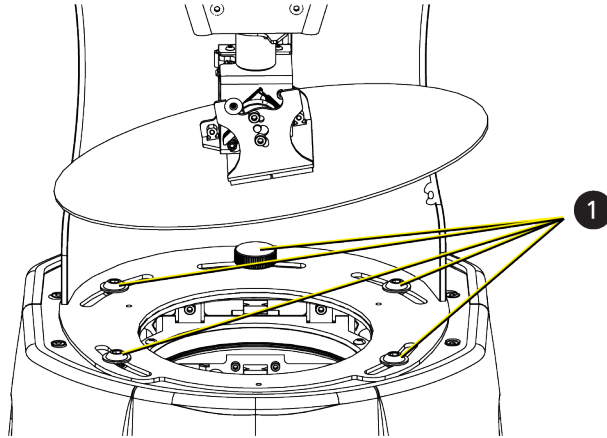

2. Rotate the mirror head to the desired position.
3. Tighten the screws.

Replace a Gobo



CAUTION: RISK OF ELECTRIC SHOCK! Disconnect power before servicing.

ATTENTION : RISQUE DE CHOC ÉLECTRIQUE! Couper l'alimentation avant l'entretien.



Note: ETC recommends that you wear clean cotton gloves when changing gobos to protect the gobos from dirt and fingerprints.

Considerations for Custom Gobos

If you are installing a custom gobo, a metal gobo mounting ring with alignment tab is available from ETC to help with the alignment of gobos between fixtures. Contact ETC or your authorized ETC dealer to order part number H7900110 for standard gobos and 2570A3022 for gobos in which the image covers the full diameter of the gobo, such as the Ice gobo.

Artwork must be mirrored on the gobo, as shown in the graphic that follows, because the artwork is flipped horizontally when it is projected off of the fixture's mirror.

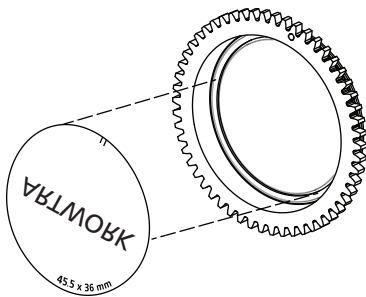

ETC recommends that custom gobos for use in the Cyberlight LED fixture be BOROFLOAT® or aluminum material.

Remove the Effects Module



Tip: If you position the fixture on its side when removing the effects module, ETC recommends that you tilt the yoke toward the head of the fixture to increase the stability of the fixture.

Tool required:

- #2 Phillips screwdriver

1. Disconnect power to the fixture and allow it to cool completely before continuing.

2. Remove the fixture cover from the front of the fixture.
 - a. Using a #2 Phillips screwdriver, loosen the four captured Phillips screws that secure the cover to the fixture.
 - b. Lift the cover away from the fixture, and detach the safety tether from the fixture enclosure to completely remove the cover.

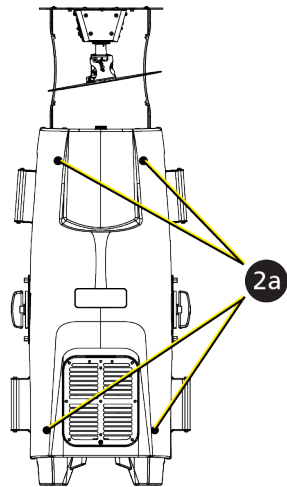

CAUTION: *Before you remove the effects module, ensure that the lenses are positioned out of the way so there is no contact between the lenses and the effects module components. If necessary, push the focus lens toward the mirror to manually move the focus lens along the guide. Be careful not to touch the lens itself.*

3. Remove the effects module from the fixture.
 - a. Disconnect the power/control wires from the effects module.
 - b. Using a #2 Phillips screwdriver, remove the two screws that attach the effects module to the fixture. Save the screws. You will use them to reinstall the effects module in the fixture.
 - c. Gently slide the effects module from the fixture.

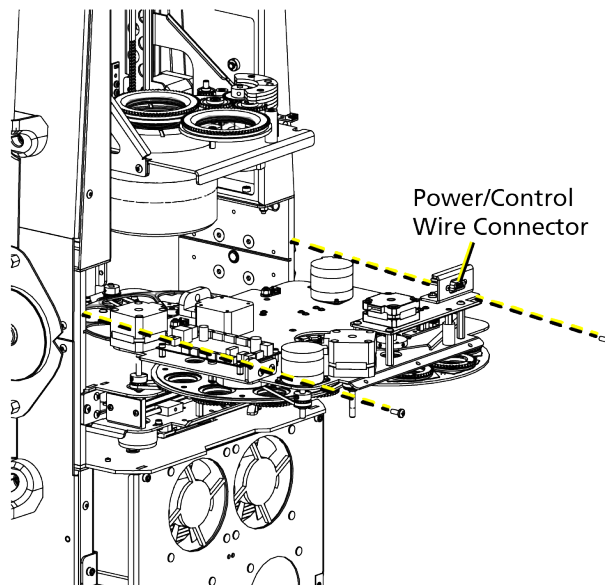

Replace a Gobo

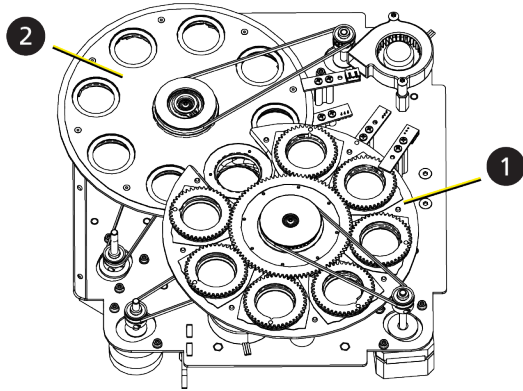

Item	Description
1	Gobo wheel 1
2	Gobo wheel 2



Note: The illustrations used in this procedure display gobo wheel 1. The procedure for replacing a gobo in gobo wheel 2 is the same with one exception; ETC recommends that you set the effects module on the work surface with the gobo wheels down for easier access to the gobos in gobo wheel 2.

Part required:

- Replacement gobo

Tool required:

- Flatblade jeweler's screwdriver
1. Place the effects module on a clean, flat work surface.
 2. Locate the gobo you want to remove.
 3. Remove the gobo carrier from the gobo wheel.
 - a. Lift the edges of the gobo carrier to lift the carrier out of its slot in the gobo wheel.
 - b. Pull the carrier out of the gobo wheel.

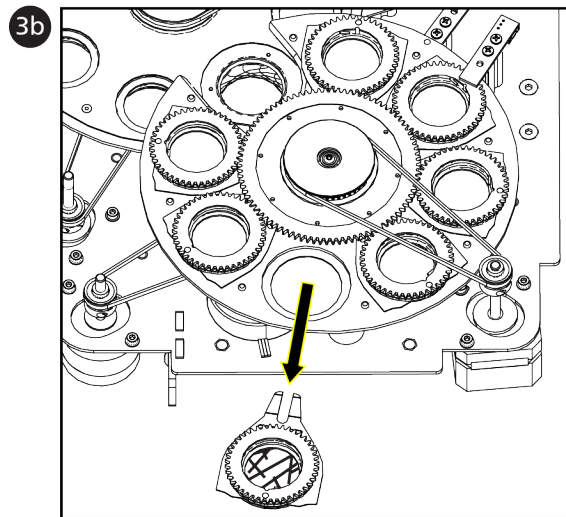
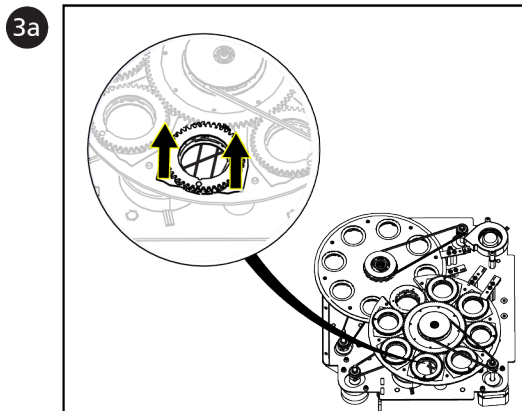

4. Remove the gobo from the gobo carrier.
 - a. Use a flatblade jeweler's screwdriver to carefully pry the spring out of the gobo carrier.

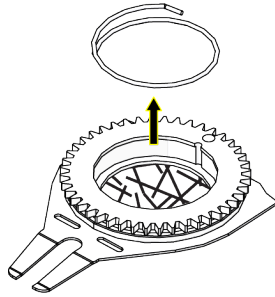

- b. Remove the gobo media from the gobo carrier.
5. Identify the reflective side of the new gobo. The reflective side must be oriented in the gobo carrier so that when the effects module is installed in the fixture, the reflective side is toward the LED engine.

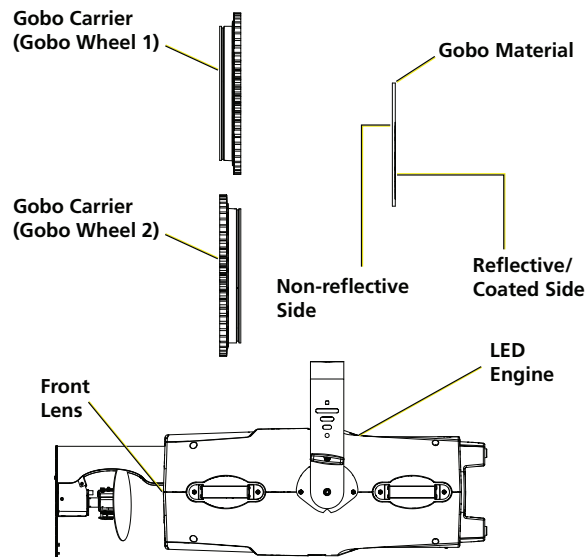

6. Insert the new gobo into the gobo carrier.
 - a. Verify that the reflective side of the gobo is correctly oriented with the reflective side up (if installing in gobo wheel 1) or down (if installing in gobo wheel 2).
 - b. Align the alignment tab on the gobo with the notch in the gobo carrier.

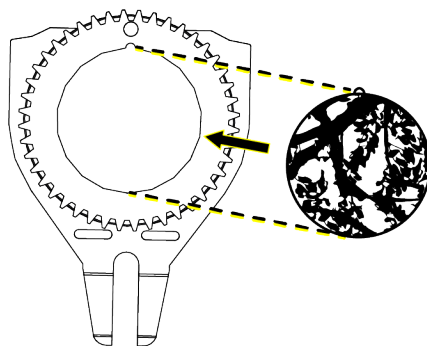

7. Carefully insert the spring into the gobo carrier to secure the gobo.

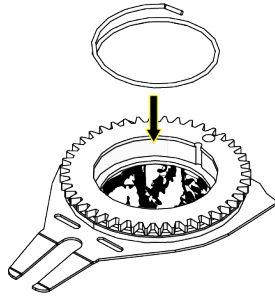

8. Each gobo carrier in the gobo wheel has a magnet that must be aligned with the sun gear (central hub) of the gobo wheel before you install the new gobo. This ensures proper rotation of the gobos with respect to each other.
- Rotate the sun gear of the gobo wheel until the magnet on each gobo carrier in the gobo wheel is aligned with its corresponding alignment key on the sun gear.



Note: If you are unable to align all of the gobos appropriately as shown below, contact ETC Technical Services for assistance.

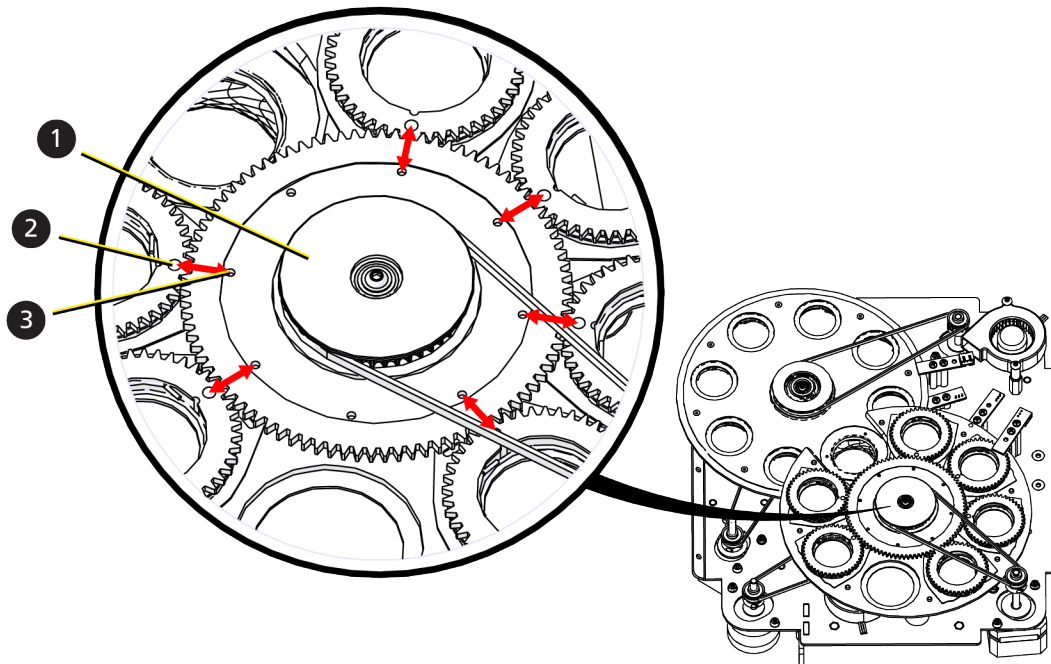

Item	Description
1	Sun gear
2	Magnet
3	Alignment key

- For the new gobo you are installing, rotate the sun gear on the gobo carrier so that the magnet is centered between the forks of the gobo carrier.

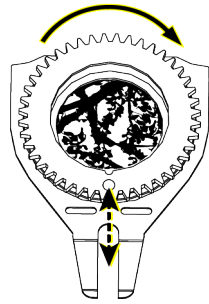

- Slide the gobo carrier partially into the gobo wheel making sure the forks on the gobo carrier fit on either side of the post beneath the rotating sun gear on the gobo wheel. Do not engage the gears on the gobo carrier with the gears on the gobo wheel at this time.

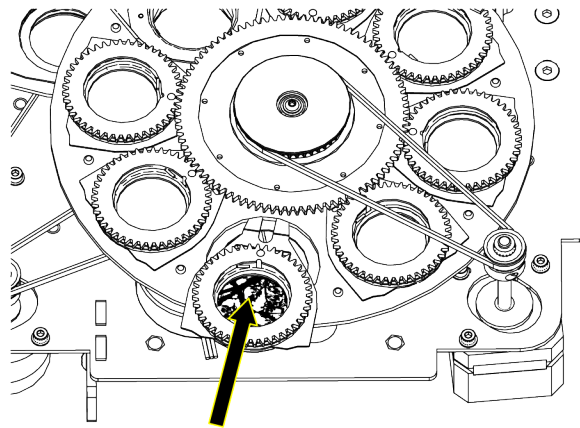

- Verify that the magnet on the gobo carrier is aligned with the alignment key on the sun gear on the gobo wheel. If necessary, rotate the sun gear on the gobo carrier to adjust the location of the magnet being careful to not rotate the sun gear on the gobo wheel.
- Push the gobo carrier into the gobo wheel until the gobo carrier is firmly seated in its slot in the gobo wheel.
- Verify that the magnet on each gobo carrier in the gobo wheel is aligned with the sun gear as shown in step 8. If realignment is necessary:
 - Remove the gobo carrier you installed in step 12 from the gobo wheel.
 - Repeat this procedure beginning at step 8 being careful not to turn the sun gear as you perform steps 10–12.

Install the Effects Module

Tool required:

- #2 Phillips screwdriver

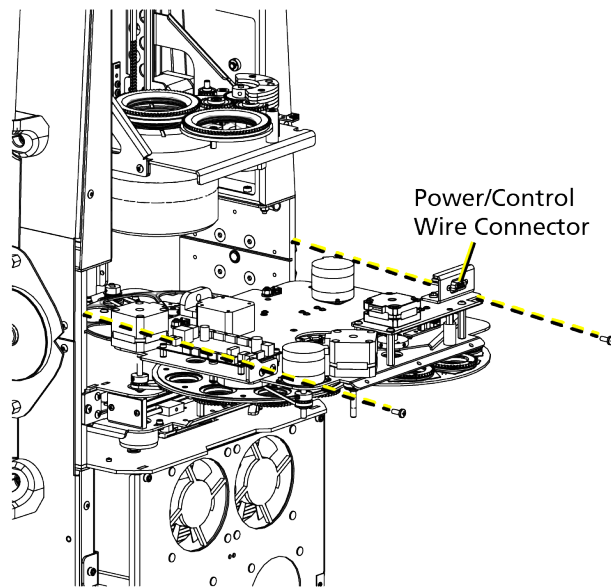

1. Carefully slide the effects module into the fixture.
2. Using a #2 Phillips screwdriver and the two screws you set aside when you removed the effects module, secure the effects module to the fixture.
3. Connect the power wires to the effects module.
4. Reinstall the fixture cover.
 - a. Align the cover to the fixture and reattach the safety tether to the fixture enclosure.
 - b. Using a #2 Phillips screwdriver, tighten the four captured Phillips screws to secure the cover to the fixture.

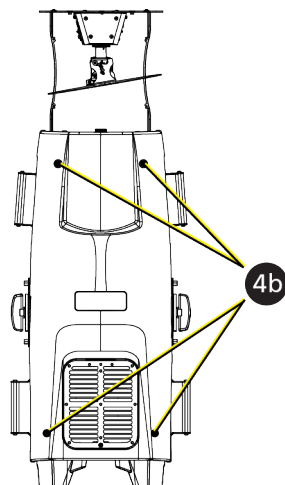

Replace Color Media



CAUTION: RISK OF ELECTRIC SHOCK! Disconnect power before servicing.

ATTENTION : RISQUE DE CHOC ÉLECTRIQUE! Couper l'alimentation avant l'entretien.



Note: ETC recommends that you wear gloves when changing color media to protect the media from dirt and fingerprints.

Remove the Color Module



Tip: If you position the fixture on its side when removing the color module, ETC recommends that you tilt the yoke toward the head of the fixture to increase the stability of the fixture.

Tool required:

- #2 Phillips screwdriver
1. Disconnect power to the fixture and allow it to cool completely before continuing.
 2. Remove the fixture cover from the front of the fixture.
 - a. Using a #2 Phillips screwdriver, loosen the four captured Phillips screws that secure the cover to the fixture.
 - b. Lift the cover away from the fixture, and detach the safety tether from the fixture enclosure to completely remove the cover.

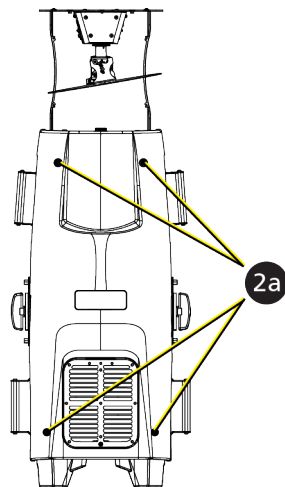

3. Remove the color module from the fixture.
 - a. Disconnect the power/control wires from the color module.
 - b. Using a #2 Phillips screwdriver, remove the two screws that attach the color module to the fixture. Save the screws. You will use them to reinstall the color module in the fixture.
 - c. Gently remove the module from the fixture.

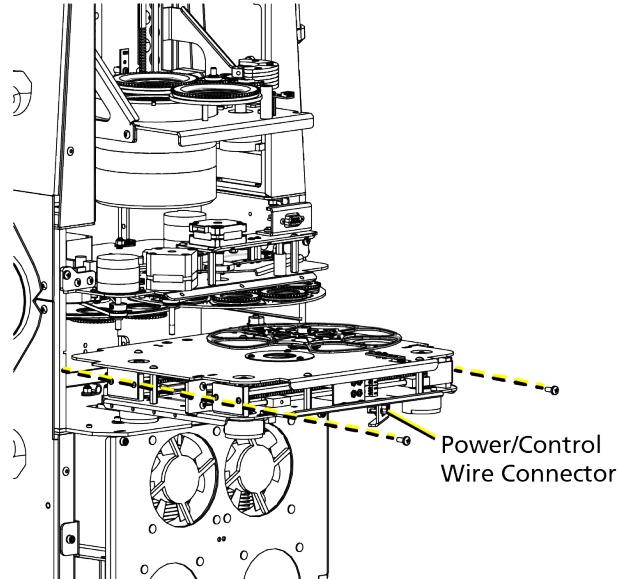

Replace Color Media

Part required:

- Color media installed in a carrier
1. Place the color module on a clean, flat work surface with the color wheel faceup.
 2. Gently press up on the underside of the color media you want to remove to lift the media away from the color wheel, and pull the media out of the color wheel.

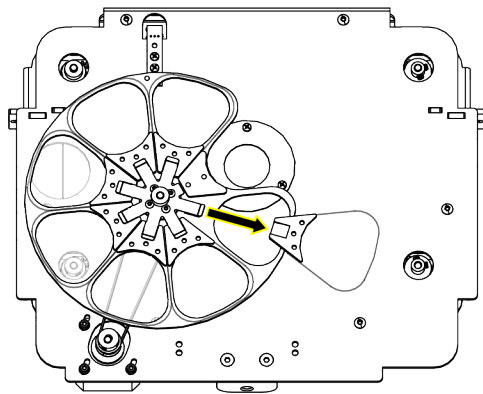

3. Insert the replacement color media into the color wheel making sure to fully seat the media in the color wheel.

Install the Color Module

Tool required:

- #2 Phillips screwdriver

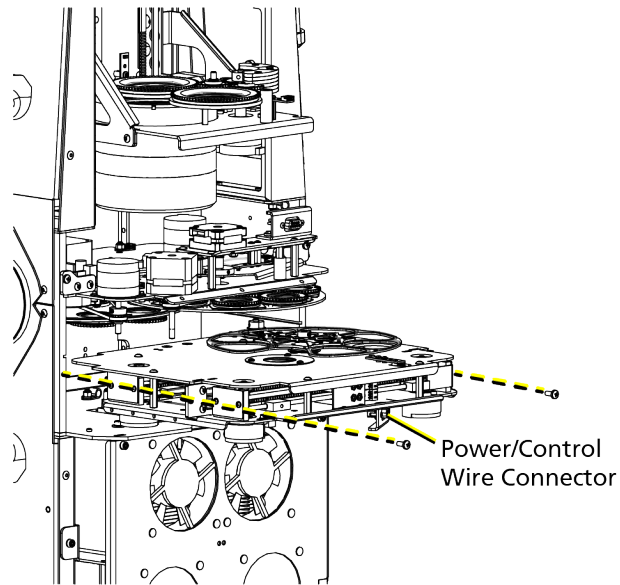

1. Carefully slide the color module into the fixture.
2. Using a #2 Phillips screwdriver and the two screws you set aside when you removed the color module, secure the color module to the fixture.
3. Connect the power wires to the color module.
4. Reinstall the fixture cover.
 - a. Align the cover to the fixture and reattach the safety tether to the fixture enclosure.
 - b. Using a #2 Phillips screwdriver, tighten the four captured Phillips screws to secure the cover to the fixture.

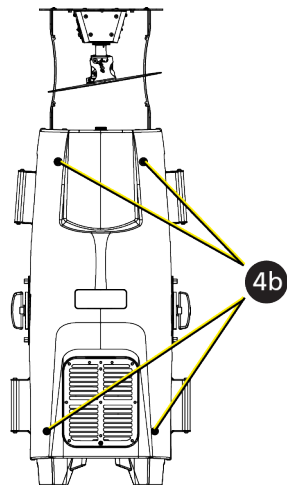

Install the Snoot Accessory

A snoot accessory for the Cyberlight LED fixture is available separately for purchase. Contact ETC Technical Services or your authorized ETC dealer for information. See [Help from Technical Services on page 7](#) for contact information.

The snoot accessory kit contains the snoot and three M3x4 mm hex screws.

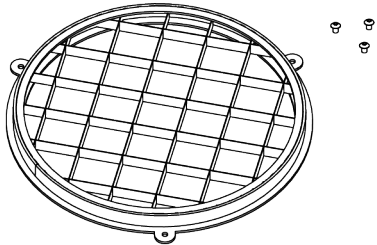

Tool needed:

- 2.0 mm hex key

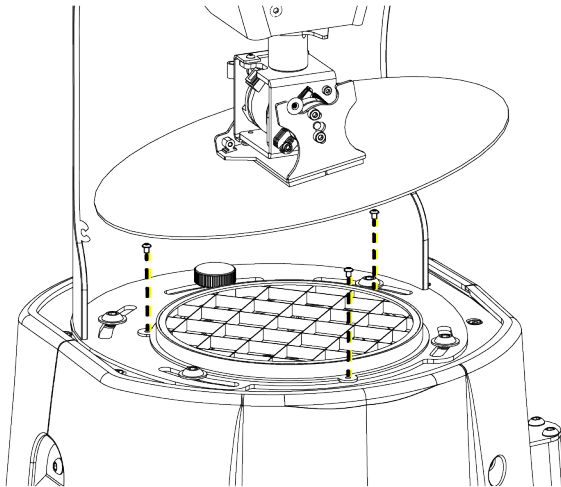

1. Align the snoot below the mirror in the mirror head so that the three screw holes in the snoot align with the three screw holes in the mirror head.
2. Using a 2.0 mm hex key and the three M3x4 mm hex screws, secure the snoot to the mirror head.

Error Codes

When you apply power to the fixture, it runs a calibration (homing) sequence. If the fixture detects errors during calibration, a red error notification appears at the bottom of the UI display and details about the errors are listed in Main Menu → Diagnostics → Errors.

Contact ETC Technical Services for assistance in remedying the errors. See [Help from Technical Services on page 7](#) for contact information.

Error	Description	Remedy
Color Mod PCB NR	The fixture could not detect the color module board.	<ul style="list-style-type: none"> • Verify that the color module D-sub connector is plugged in. • Check the LED status on the color driver board. • Check the color module fuse. • Check the color module board wiring and verify that wires are not broken or unplugged from the color driver board or the fuse/data board. <p>CAUTION: Do not hot plug the D-sub connector. Damage to the fixture could occur.</p>
Color Wheel Sensor	The fixture could not detect the sensor for the color wheel.	<ul style="list-style-type: none"> • In the main menu, navigate to Diagnostics → Sensor, move the color wheel to a position where the magnet is near the sensor, and verify that the sensor is working. • Check the sensor PCB wiring and verify that wires are not broken or unplugged from the sensor or motor driver board. • Confirm that the color wheel is not obstructed and is able to move freely.
CTO Sensor	The fixture could not detect the sensor for the CTO flag.	<ul style="list-style-type: none"> • In the main menu, navigate to Diagnostics → Sensor, move the CTO flag to a position where the magnet is near the sensor, and verify that the sensor is working. • Check the sensor PCB wiring and verify that wires are not broken or unplugged from the sensor or motor driver board. • Confirm that the CTO flag is not obstructed and is able to move freely.
Cyan Sensor	The fixture could not detect the sensor for the cyan flag.	<ul style="list-style-type: none"> • In the main menu, navigate to Diagnostics → Sensor, move the cyan flag to a position where the magnet is near the sensor, and verify that the sensor is working. • Check the sensor PCB wiring and verify that wires are not broken or unplugged from the sensor or motor driver board. • Confirm that the cyan flag is not obstructed and is able to move freely.
EE-R Write Error	The fixture could not write to the internal setting memory.	In the main menu, navigate to Settings → Restore Defaults and reset the fixture's defaults to the factory defaults.
Focus Sensor	The fixture could not detect the sensor for the focus carriage.	<ul style="list-style-type: none"> • In the main menu, navigate to Diagnostics → Sensor, move the focus carriage to a position where the magnet is near the sensor, and verify that the sensor is working. • Check the sensor PCB wiring and verify that wires are not broken or unplugged from the sensor or motor driver board. • Confirm that the focus carriage is not obstructed and is able to move freely.
Frost Sensor	The fixture could not detect the sensor for the light diffusion.	<ul style="list-style-type: none"> • In the main menu, navigate to Diagnostics → Sensor, move the light diffusion to a position where the magnet is near the sensor, and verify that the sensor is working. • Check the sensor PCB wiring and verify that wires are not broken or unplugged from the sensor or motor driver board. • Confirm that the light diffusion flag is not obstructed and is able to move freely.

Error	Description	Remedy
Frost 1 Sensor	The fixture could not detect the sensor for the heavy diffusion.	<ul style="list-style-type: none"> In the main menu, navigate to Diagnostics → Sensor, move the heavy diffusion to a position where the magnet is near the sensor, and verify that the sensor is working. Check the sensor PCB wiring and verify that wires are not broken or unplugged from the sensor or motor driver board. Confirm that the heavy diffusion flag is not obstructed and is able to move freely.
Gobo 1 Fan Failed	The gobo 1 fan did not spin.	<ul style="list-style-type: none"> Check that the fan is not obstructed. Check that the fan is plugged in and all associated wire harnesses are plugged in.
Gobo 2 Fan Failed	The gobo 2 fan did not spin.	<ul style="list-style-type: none"> Check that the fan is not obstructed. Check that the fan is plugged in and all associated wire harnesses are plugged in.
Gobo Mod PCB NR	The fixture could not detect the gobo module board.	<ul style="list-style-type: none"> Verify that the gobo module D-sub connector is plugged in. Check the LED status on the gobo driver board. Check the gobo module fuse. Check the gobo module board wiring and verify that wires are not broken or unplugged from the gobo driver board or the fuse/data board. <p>CAUTION: Do not hot plug the D-sub connector. Damage to the fixture could occur.</p>
LED Driver NR	The fixture could not detect the LED driver board.	<ul style="list-style-type: none"> Verify that the data connector is plugged in. Check the LED status on the LED driver board. Check the LED driver module power connector. Check the LED driver board wiring and verify that wires are not broken or unplugged from the LED driver board or the fuse/data board.
LED Intake Fan 1 Failed	LED cooling fan 1 did not spin.	<ul style="list-style-type: none"> Check that the fan is not obstructed and can move freely. Check that the fan is plugged in and all associated wire harnesses are plugged in.
LED Intake Fan 2 Failed	LED cooling fan 2 did not spin.	<ul style="list-style-type: none"> Check that the fan is not obstructed and can move freely. Check that the fan is plugged in and all associated wire harnesses are plugged in.
LED Exhaust Fan 3 Failed	LED cooling fan 3 did not spin.	<ul style="list-style-type: none"> Check that the fan is not obstructed and can move freely. Check that the fan is plugged in and all associated wire harnesses are plugged in.
LED Exhaust Fan 4 Failed	LED cooling fan 4 did not spin.	<ul style="list-style-type: none"> Check that the fan is not obstructed and can move freely. Check that the fan is plugged in and all associated wire harnesses are plugged in.
Lens Mod PCB NR	The fixture could not detect the lens module.	<ul style="list-style-type: none"> Verify that the lens module D-sub connector is plugged in. Check the LED status on the lens driver board. Check the lens module fuse. Check the lens module board wiring and verify that wires are not broken or unplugged from the lens driver board or the fuse/data board. <p>CAUTION: Do not hot plug the D-sub connector. Damage to the fixture could occur.</p>
Magenta Sensor	The fixture could not detect the sensor for the magenta flag.	<ul style="list-style-type: none"> In the main menu, navigate to Diagnostics → Sensor, move the magenta flag to a position where the magnet is near the sensor, and verify that the sensor is working. Check the sensor PCB wiring and verify that wires are not broken or unplugged from the sensor or motor driver board. Confirm that the magenta flag is not obstructed and is able to move freely.

Error	Description	Remedy
Over Temp Error	A sensor detected a temperature that is higher than the allowed maximum temperature.	<ul style="list-style-type: none"> In the main menu, navigate to Diagnostics → Temperatures to determine what caused the error. Check that the dust filters are clean and fans are clean and running. Check the installation site and verify that hot air is not being pulled into the fixture's air intakes. Verify that the rated ambient temperature has not been exceeded.
Pan and Tilt PCB NR	The fixture could not detect the pan/tilt board.	<ul style="list-style-type: none"> Check the LED status on the pan/tilt board. Check the pan/tilt fuse. Check the pan/tilt board wiring and verify that wires are not broken or unplugged from the pan/tilt board or the fuse/data board.
Pan Driver Fault	The pan driver board detected a fault in the pan motor.	Check the pan motor wiring for broken or disconnected wires.
Pan Encoder Error	The pan encoder lost communication with the pan driver board.	<ul style="list-style-type: none"> In the main menu, navigate to Diagnostics → Sensors → Pan Encoder to verify operation of the encoder. Check that the pan encoder harness and verify that wires are not broken or unplugged from the encoder or pan driver board.
Pan Encoder Time Out	The fixture could not move the pan motor to its correct position and timed out.	Check that the mirror is not obstructed and can move freely.
Prism Arm Sensor	The fixture could not detect the sensor for the prism.	<ul style="list-style-type: none"> In the main menu, navigate to Diagnostics → Sensor, move the prism to a position where the magnet is near the sensor, and verify that the sensor is working. Check the sensor PCB wiring and verify that wires are not broken or unplugged from the sensor or motor driver board. Confirm that the prism is not obstructed and is able to move freely.
PSU Exhaust Fan 1 Failed	Power supply fan 1 did not spin.	<ul style="list-style-type: none"> Check that the fan is not obstructed and can move freely. Check that the fan is plugged in and all associated wire harnesses are plugged in.
PSU Exhaust Fan 2 Failed	Power supply fan 2 did not spin.	<ul style="list-style-type: none"> Check that the fan is not obstructed and can move freely. Check that the fan is plugged in and all associated wire harnesses are plugged in.
PSU Intake Fan 3 Failed	Power supply fan 3 did not spin.	<ul style="list-style-type: none"> Check that the fan is not obstructed and can move freely. Check that the fan is plugged in and all associated wire harnesses are plugged in.
PSU Intake Fan 4 Failed	Power supply fan 4 did not spin.	<ul style="list-style-type: none"> Check that the fan is not obstructed and can move freely. Check that the fan is plugged in and all associated wire harnesses are plugged in.
Tilt Driver Fault	The pan driver board detected a fault in the tilt motor.	Check the tilt motor wiring for broken or disconnected wires.
Tilt Encoder Error	The tilt encoder lost communication with the pan driver board.	<ul style="list-style-type: none"> In the main menu, navigate to Diagnostics → Sensors → Tilt Encoder to verify operation of the encoder. Check that the tilt encoder harness and verify that wires are not broken or unplugged from the encoder or pan driver board.
Tilt Encoder Time Out	The fixture could not move the tilt motor to its correct position and timed out.	Check that the mirror is not obstructed and can move freely.
R Gobo 1 Rotate Sensor	The fixture could not detect the sensor for at least one rotating gobo in gobo wheel 1.	<ul style="list-style-type: none"> In the main menu, navigate to Diagnostics → Sensor, move a gobo on rotating gobo wheel 1 to a position where the magnet is near the sensor, and verify that the sensor is working. Check the sensor PCB wiring and verify that wires are not broken or unplugged from the sensor or motor driver board. Confirm that the gobos in rotating gobo wheel 1 are not obstructed and are able to move freely.

Error	Description	Remedy
R Gobo 2 Rotate Sensor	The fixture could not detect the sensor for at least one rotating gobo in gobo wheel 2.	<ul style="list-style-type: none"> In the main menu, navigate to Diagnostics → Sensor, move a gobo on rotating gobo wheel 2 to a position where the magnet is near the sensor, and verify that the sensor is working. Check the sensor PCB wiring and verify that wires are not broken or unplugged from the sensor or motor driver board. Confirm that the gobos in rotating gobo wheel 2 are not obstructed and are able to move freely.
R Gobo 1 Wheel Sensor	The fixture could not detect the sensor for rotating gobo wheel 1.	<ul style="list-style-type: none"> In the main menu, navigate to Diagnostics → Sensor, move rotating gobo wheel 1 to a position where the magnet is near the sensor, and verify that the sensor is working. Check the sensor PCB wiring and verify that wires are not broken or unplugged from the sensor or motor driver board. Confirm that rotating gobo wheel 1 is not obstructed and is able to move freely.
R Gobo 2 Wheel Sensor	The fixture could not detect the sensor for rotating gobo wheel 2.	<ul style="list-style-type: none"> In the main menu, navigate to Diagnostics → Sensor, move rotating gobo wheel 2 to a position where the magnet is near the sensor, and verify that the sensor is working. Check the sensor PCB wiring and verify that wires are not broken or unplugged from the sensor or motor driver board. Confirm that rotating gobo wheel 2 is not obstructed and is able to move freely.
Yellow Sensor	The fixture could not detect the sensor for the yellow flag.	<ul style="list-style-type: none"> In the main menu, navigate to Diagnostics → Sensor, move the yellow flag to a position where the magnet is near the sensor, and verify that the sensor is working. Check the sensor PCB wiring and verify that wires are not broken or unplugged from the sensor or motor driver board. Confirm that the yellow flag is not obstructed and is able to move freely.
Zoom Sensor	The fixture could not detect the sensor for the zoom carriage.	<ul style="list-style-type: none"> In the main menu, navigate to Diagnostics → Sensor, move the zoom carriage to a position where the magnet is near the sensor, and verify that the sensor is working. Check the sensor PCB wiring and verify that wires are not broken or unplugged from the sensor or motor driver board. Confirm that the zoom carriage is not obstructed and is able to move freely.

Maintenance



CAUTION: RISK OF ELECTRIC SHOCK! Disconnect power before servicing.

ATTENTION : RISQUE DE CHOC ÉLECTRIQUE! Couper l'alimentation avant l'entretien.

To ensure that the fixture remains in good working condition and does not fail prematurely, ETC recommends that you perform regular maintenance on the fixture.

Keep the following in mind during regular service and inspection:

- All screws for installing the fixture or parts of the fixture must be tightly connected and must not be corroded.
- There must not be any deformations to the housing, lenses, rigging, and installation points (ceiling, suspension, trussing).
- Moving parts must not show any signs of wear and must move smoothly without issue.
- The power supply cables must not show any damage, material fatigue, or sediment.
- If spare parts are required, order only genuine parts from ETC or your authorized ETC dealer.

Clean Fans and Dust Filters

The Cyberlight LED fixture contains eight fans: four on each side of the fixture. The fans are located behind the fan doors near the rear of the fixture. Clean the fans and dust filters regularly to ensure maximum airflow and efficient cooling.

Tools required:

- #2 Phillips screwdriver
- Vacuum
- Compressed air
- Water and mild soap (optional)

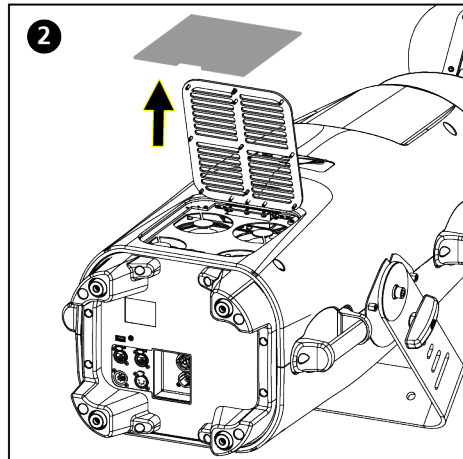
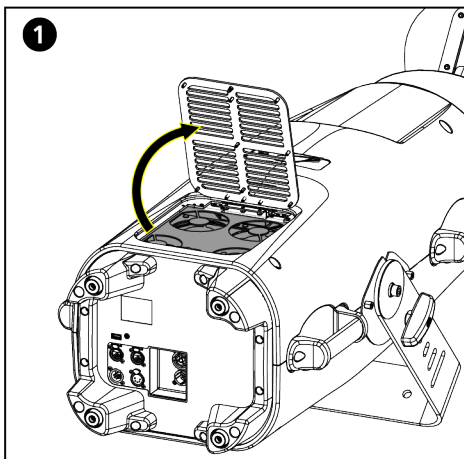

1. Use the #2 Phillips screwdriver to loosen the captured screw in the fan door, and open the door.
2. Remove the dust filter from the fixture.

3. Clean the dust filter by vacuuming, using compressed air, or washing with mild soap and water.



Note: *If you clean the dust filter with soap and water, ensure the dust filter is dry before you return it to the fixture.*

4. Clean the fans.
 - a. Use a vacuum to clean the protective screens.
 - b. Use a vacuum or compressed air to clean the fans.



Note: *If you use compressed air to clean the fans, hold the fans in place while cleaning them. Letting the fans spin while using compressed air could damage the fans.*

5. Install the dust filter in the fixture.
6. Close the fan door and tighten the captured screw.
7. Repeat this procedure to clean the fans and dust filter on the other side of the fixture.

Clean the Mirror

Clean the mirror and the output window only when necessary, and only use a Silky Microfiber Optical Cloth with purified water or an ammonia-free glass cleaner such as Miller Stevenson MS-260 Glass Cleaner.

Replace the Fuse

The fuse in this fixture is not user-replaceable. Contact ETC Technical Services for assistance. See [Help from Technical Services on page 7](#) for contact information.

Compliance

For current and complete compliance information, view the product datasheet at etconnect.com/Products/Automated-Fixtures. For complete product documentation, including compliance documentation, visit etconnect.com/products.

FCC Compliance

Cyberlight LED

(For any FCC matters):

Electronic Theatre Controls, Inc.
3031 Pleasant View Road
Middleton, WI 53562
+1 (608) 831-4116
etconnect.com

This device complies with Part 15 of the FCC Rules. Operation is subject to the following two conditions: (1) this device may not cause harmful interference, and (2) this device must accept any interference received; including interference that may cause undesired operation. Visit etconnect.com/products for current and complete compliance information including FCC compliance.



Note: *This equipment has been tested and found to comply with the limits for a Class A digital device, pursuant to Part 15 of the FCC rules. These limits are designed to provide reasonable protection against harmful interference when the equipment is operated in a commercial environment. This equipment generates, uses, and can radiate radio frequency energy and, if not installed and used in accordance with the instructions, may cause harmful interference to radio communications. Any modifications or changes to this product not expressly approved by Electronic Theatre Controls, Inc. could void the user's authority to operate the product. Operation of this equipment in a residential area is likely to cause harmful interference, in which case the user will be required to correct the interference at their own expense.*



Corporate Headquarters ■ Middleton, WI, USA | +1 608 831 4116
Global Offices ■ London, UK | Rome, IT | Holzkirchen, DE | Paris, FR | Hong Kong | Dubai, UAE | Singapore
New York, NY | Orlando, FL | Los Angeles, CA | Austin, TX | © 2025 Electronic Theatre Controls, Inc.
Web [etconnect.com](https://www.etconnect.com) | **Support** support.etconnect.com | **Contact** [etconnect.com/contactETC](https://www.etconnect.com/contactETC)
Trademark and patent info: [etconnect.com/ip](https://www.etconnect.com/ip) | Third-party license agreement info: [etconnect.com/licenses](https://www.etconnect.com/licenses)
Product information and specifications subject to change. ETC intends this document to be provided in its entirety.
2597M1200-1.0.5 Rev B Released 2025-01