

# **Model 5421**

## **Dante® Intercom Audio Engine**

### **User Guide**

Issue 4, June 2025

This User Guide is applicable for serial numbers M5421-00151 and later with Main Firmware version 2.00 and later and FPGA Firmware version 2.01 and later

**Copyright © 2025 by Studio Technologies, Inc., all rights reserved**  
studio-tech.com

This page intentionally left blank.

## Table of Contents

|                                                                                                                                            |    |
|--------------------------------------------------------------------------------------------------------------------------------------------|----|
| Revision History .....                                                                                                                     | 4  |
| Introduction .....                                                                                                                         | 5  |
| Getting Started.....                                                                                                                       | 7  |
| Dante Configuration .....                                                                                                                  | 10 |
| Model 5421 Configuration.....                                                                                                              | 12 |
| Operation .....                                                                                                                            | 22 |
| Technical Notes .....                                                                                                                      | 22 |
| Specifications.....                                                                                                                        | 26 |
| Appendix A–STcontroller Default Configuration Values .....                                                                                 | 27 |
| Appendix B–Graphical Description of the Installation Kit for Panel-Cutout or<br>Surface-Mounting Use (Order Code RMBK-10) .....            | 28 |
| Appendix C–Graphical Description of Left- or Right-Side Rack-Mount Installation Kit for<br>One “1/2- Rack” Unit (Order Code RMBK-11) ..... | 29 |
| Appendix D–Graphical Description of Rack-Mount Installation Kit for Two “1/2- Rack” Units<br>(Order Code RMBK-12) .....                    | 30 |
| Appendix E–Graphical Description of Center Rack-Mount Installation Kit for One “1/2- Rack”<br>Unit (Order Code RMBK-13).....               | 31 |
| Appendix F–Example of Model 5421 Routes (Subscriptions) made using Dante Controller....                                                    | 32 |

## Revision History

### **Issue 4, June 2025:**

- Adds notes about incompatibility between Party-Line w/Auto Mix mode and high-frequency call functions.

### **Issue 3, June 2023:**

- Documents new audio engine configuration choices.
- Updated to meet latest document format.

### **Issue 2, September 2022:**

- Updated for clarity.

### **Issue 1, March 2020:**

- Initial release of complete document.

## Introduction

The Model 5421 Dante Intercom Audio Engine is a high-performance, cost-effective, and flexible solution for creating party-line (PL) intercom circuits when used with Dante®-compatible products. It's directly compatible with the Studio Technologies' range of 1-, 2-, and 4-channel intercom beltpacks. The Model 5421 can also prove valuable in other general-audio and broadcast-related mixing and interfacing applications. The unit is suitable for use in fixed and mobile broadcast facilities, post-production studios, commercial and educational theater environments, as well as language interpretation and entertainment applications.

Only a Gigabit Ethernet network connection with Power-over-Ethernet (PoE) support is required for the Model 5421 to provide a powerful resource in a variety of Dante applications. Front- and back-panel LEDs provide operating status indications. The Studio Technologies' STcontroller software application allows personnel to view and configure key operating parameters. The unit's lightweight "1/2-rack" enclosure can be used stand-alone or mounted in one space (1U) of a standard 19-inch rack enclosure with an optional installation kit. To meet the latest interoperability standard the Model 5421's Dante implementation meets the requirements of AES67 as well as supporting the Dante Domain Manager™ (DDM) software application. Using DDM, compliance with ST 2110-30 may be possible.

The Model 5421 provides one 16-channel audio engine which can be configured to provide from one to four

"virtual" intercom circuits or other functions. The term "audio engine" was selected to describe a set of audio input, processing, routing, and output resources that can be configured to support specific intercom and audio requirements. Unlike general-purpose Dante digital matrix devices, the Model 5421 is optimized to allow direct support for theater, small broadcast, intercom, and broadcast applications.

## Configuration and Functionality

Using the STcontroller software application, a configuration choice selects how the Model 5421's 16-channel audio engine is segmented. This allows efficient use of the Dante channels to support the needs of specific applications. As all Dante intercom beltpacks are essentially 4-wire devices (having independent receiver (input) and transmitter (output) channels), "virtual" (simulated) party-line functionality must be created within the Model 5421's digital processing resources. This requires that the maximum number of participants (users) on any one "party-line" be defined and an appropriate configuration be made.

## Group Size

The 16 channels offered by the Model 5421 are configured into what are called groups. Simple configuration choices are accessed using the STcontroller software application and allow the number of groups and their sizes to be selected. Group configuration can range from one group having 16 channels (a complete audio engine being used for a single group) to four groups each having four channels. The size of a group will



**Figure 1. Model 5421 Dante Intercom Audio Engine "throw down" front view and back views**

dictate how many devices and associated users can be part of any one party-line. Five choices allow a range of group configurations to be selected with the default setting being two 8-channel groups.

## Group Labels

From the factory, the Model 5421 will assign a unique, although somewhat-generic name (Dante label) to each group. However, using the Dante Controller application the name of each group can be edited as desired. A revised label would typically reflect how the specific group is going to be utilized. Labels such as Camera PL, Lighting, Pyro, IFB Mix, or Engineering would typically be used in broadcast- or live-event-oriented intercom applications. The configured labels are automatically used by the Model 5421's Dante interface and can provide clarity when routing Dante channels using applications such as Dante Controller. Each group label can be a combination of up to 14 alpha or numeric characters. Channel numbers are automatically appended to the entered labels to provide identification of the specific channels within the Dante environment. A label of up to 12 additional characters can also be added to each specific group channel, providing further details about an application.

## Group Operating Modes

While the primary application for the Model 5421 is to create party-line (PL) intercom circuits, each group can be independently configured from among five operating modes: Party-Line w/Auto Mix, Party-Line, Summing Bus w/Auto Mix, Summing Bus, and Pass-Thru.

### Party-Line

When a group is configured for either the Party-Line w/Auto Mix or the Party-Line operating mode, the Model 5421's audio processing circuitry creates a series of independent "mix-minus" outputs, one for each channel in the group. These specialized outputs allow each intercom user assigned to that specific group (a "party-line") to hear all members of that group except for themselves. (This is the origin of the term mix-minus and indicates a mix of all sources but themselves.) By each user receiving a mix-minus signal precise control of each user's sidetone audio level and overall audio quality can be maintained. Selecting the Party-Line w/Auto Mix operating mode offers Model 5421 users a level of audio performance that is unique among intercom applications.

### Summing Bus

When a group is configured for either the Summing Bus w/Auto Mix or the Summing Bus operating mode, audio sources assigned to the group's input channels are mixed (summed or combined) at unity gain. (No gain or attenuation is applied to the input signals.) The resulting mix is routed to all the output channels associated with that group. Either summing bus operating mode can be useful for general-purpose audio mixing applications where multiple Dante channels need to be combined. However, when the Summing Bus w/Auto Mix operating mode is selected, it may allow a Model 5421 to be useful in many applications that go well beyond broadcast intercom. This mode may prove especially useful in audio applications that require combining many voice sources. Press conferences, sports interview configurations, and government meeting situations may all benefit from this capability.

### Pass-Thru

Each group can be independently configured for a unique operating mode called Pass-Thru. This implements an audio function that routes each Dante receiver (input) channel directly to an associated Dante transmitter (output) channel. This simple but sophisticated function will allow any Dante signal to utilize the Model 5421's capability to support up to 16 Dante flows. This can be useful as a "flow expander" when used in an application that includes Dante-compatible products that utilize Audinate's Ultimo™ integrated circuit. (Many products from Studio Technologies use Ultimo.) While an excellent cost-effective means of implementing Dante, using Ultimo has several limitations. The first is its ability to support only two Dante transmitter (output) and two Dante receiver (input) flows. Routing Dante signals through Model 5421 pass-thru channels can facilitate integration with applications that require additional flows. With the unit's ability to support AES67 and the Dante Domain Manager (DDM) application, many specialized interfacing tasks can be accomplished.

## Applications

The Model 5421 is compatible with many Dante-compliant devices including the extensive range of intercom belt packs from Studio Technologies. These include the single-channel/dual-listen Model 372A and Model 373A, the 2-channel Model 370A and Model 371A, and the 4-channel Model 374A. The Model 5421

will also function directly with other Dante-supporting devices such as the Model 348 Intercom Station and Model 391 Dante Alerting Unit. In addition, the Model 5421 can function with matrix intercom systems, audio consoles, and wireless intercom base stations.

## Dante Audio-over-Ethernet

Audio data associated with the Model 5421 is sent and received using the Dante audio-over-Ethernet media networking technology. Audio signals with a sample rate of 48 kHz and a bit depth of up to 16, 24, and 32 are supported. Up to 16 Dante receiver (input) and 16 transmitter (output) channels are available to implement virtual party-line (PL) intercom circuits.

## AES67 and DDM

Using the Dante Controller software application, the Model 5421's Dante interface can be configured to support, or not support, AES67 digital audio signals. The unit is also compliant with the Dante Domain Manager (DDM) software application. DDM offers an enhanced set of network control and monitoring features, making it ideal for security-conscious applications. This may also allow the Model 5421's audio channels to support ST 2110-30.

## Pro Audio Quality and Auto Mix

The Model 5421's audio circuitry was designed to meet the demands of professional audio applications, far exceeding that of "typical" intercom products. Audio processing is performed in the digital domain using a high-speed field-programmable-gate-array (FPGA) integrated circuit. The Model 5421's Auto Mix function utilizes a sophisticated FPGA-based algorithm to provide enhanced audio intelligibility. This feature is unique to party-line (PL) intercom applications and offers the opportunity for users to obtain the finest audio performance.

## Status LEDs and Configuration

Two LEDs, located on the Model 5421's front panel, provide an indication of the Dante interface's status. LEDs associated with the back-panel RJ45 jack display the real-time status of the connected Ethernet signal. No pushbutton or configuration switches are provided. The Studio Technologies' STcontroller software application is used to configure the unit's operating parameters.

## Ethernet Data and Power Source

The Model 5421 interconnects with a local-area-network (LAN) using a standard Gigabit (1000 Mb/s) twisted-pair Ethernet signal. The physical connection is made by way of a RJ45 jack. The Model 5421's operating power is provided by a Power-over-Ethernet (PoE)-compliant Ethernet signal. For network management purposes, the unit's Ethernet interface will report to the power sourcing equipment (PSE) that it's a class 2 (low power) powered device (PD).

## Simple Installation

The Model 5421 is housed in a rugged, lightweight aluminum enclosure that is designed to be "field tough." It can be used as a standalone portable unit, supporting what's known in the broadcast world as "throw-down" applications. It also can be directly placed upon on a rack-shelf or other flat surface. Optional installation kits are available to allow one or two units to be mounted in one space (1U) of a standard 19-inch rack enclosure or mounted in a panel cutout or to a flat surface. As previously mentioned, the Model 5421 uses a standard RJ45 jack to allow fast and convenient interconnection. Initial operation will commence when a Gigabit Ethernet signal with Power-over-Ethernet (PoE) capability is connected. Normal operation will take place after the unit "boots up." This process requires approximately 30 seconds.

## Future Capabilities and Firmware Updating

The Model 5421 was designed so that its performance and capabilities can be enhanced in the future. A USB type A receptacle, accessible on the unit's back panel, allows the main firmware (embedded software) to be updated using a standard USB flash drive. To implement its Dante interface, the Model 5421 uses Audinate's Broadway™ integrated circuit. The firmware in this integrated circuit can be updated via the unit's Ethernet interface, helping to ensure that the Dante performance remains up to date.

## Getting Started

In this section, a location will be selected for the Model 5421 Dante Intercom Engine. A Gigabit Ethernet (GigE or GbE) connection that supports Power-over-Ethernet (PoE) will be made using a standard RJ45 patch cable. If desired, an optional installation kit will be used to mount one or two units into a panel cutout, flat surface, or equipment rack.

## System Components

Included in the shipping carton are a Model 5421 Dante Intercom Audio Engine and instructions on how to obtain an electronic copy of this guide. If one or two Model 5421 units are going to be mounted in a 19-inch equipment rack then an optional installation kit is required. Specific kits are available for rack-mounting one or two Model 5421 units. If an installation kit was purchased, it would typically have been shipped in a separate carton.

## Locating the Model 5421

The location of the Model 5421 will primarily depend on being within the 100-meter (325-foot) twisted pair Ethernet cable limitation. But the overall length limit can be overcome by using a fiber-optic interconnection between the Model 5421-related Ethernet switch and another Ethernet switch that's part of the application's local-area-network (LAN). With fiber interconnects there's no reason why a Dante-supported LAN can't be distributed over many miles or kilometers.

## Protecting the Enclosure

The Model 5421 is shipped as a self-contained unit suitable for portable use or placement in a semi-permanent location. Installed on the bottom of the chassis are four screw-on rubber feet. These are useful if the unit is going to be placed on surfaces where scratching of either the Model 5421's enclosure or the surface material could take place. However, the feet can be removed without the use of a tool when rack- or custom-mounting the unit.

## Making an Ethernet Connection

The Model 5421 has one RJ45 jack which is located on the unit's back panel. It requires connection with a Gigabit Ethernet (GigE or GbE) signal that also supports Power-over-Ethernet (PoE). This is typically provided by a port on a standard PoE-enabled Gigabit Ethernet switch. The required Gigabit Ethernet signal must follow the 1000BASE-T standard and meet the requirements of IEEE® 802.3af for PoE. To support power management functionality on the associated PoE switch (PSE), the Model 5421 enumerates itself as a PoE class 2 (low power) powered device (PD).

The Model 5421's Ethernet interface supports auto MDI/MDI-X and, as such, using a cross-over or "reversing" cable is not required. And while "Fast

Ethernet" (100BASE-TX or 100 Mb) may also function correctly, it's not recommended for maximum reliability.

## Mounting Options

For some applications, it might be desirable to mount one or two Model 5421 units into a panel cutout, flat surface, or equipment rack. Installation kits, purchased separately, are available from Studio Technologies. The following sections provide details on how to use the kits. Refer to Appendices B, C, D, and E for graphical descriptions of how to attach the kits.

### Panel Cutout or Surface Mounting One Model 5421 Unit

Installation kit RMBK-10 allows one Model 5421 to be mounted in a panel cutout or onto a flat surface. The kit contains two standard-length brackets and four 6-32 thread-pitch Phillips-head machine screws. Refer to Appendix B for a visual explanation.

Begin installing the kit by removing the four screw-on rubber feet from the bottom of the Model 5421's chassis. They can be removed using one's fingers to rotate them counterclockwise; no tool is required. Store the feet for possible later use.

#### *Panel Cutout or other Opening Mounting*

To prepare the unit to mount in a cutout or other opening in a panel, use a #2 Phillips screwdriver and two 6-32 machine screws to attach one of the standard-length brackets onto the left side (when viewed from the front) of the Model 5421's enclosure. Orient the standard-length bracket such that its front is parallel to the Model 5421's front panel. Using two additional 6-32 machine screws, attach the other standard-length bracket onto the right side of the Model 5421's enclosure. The screws will mate with the threaded fasteners that can be seen on the sides of the Model 5421's enclosure, near the front of the unit.

Once the two standard-length brackets have been installed, the Model 5421 will be ready to be mounted into an opening. Secure the unit's left and right sides into the opening using two mounting screws per side.

#### *Flat Surface Mounting*

To prepare the unit to be mounted onto a flat surface simply requires the standard-length brackets be attached to the Model 5421 at 90 degrees from how they are mounted for use in a panel cutout. Use a #2 Phillips screwdriver and two 6-32 machine screws to

attach one of the standard-length brackets onto the left side (when viewed from the front) of the enclosure. Orient the bracket such that its front is parallel with the top surface of the Model 5421's enclosure. Following the same orientation, use two additional 6-32 machine screws to attach the other standard-length bracket onto the right side of the Model 5421's enclosure. The screws will mate with the threaded fasteners that can be seen on the sides of the Model 5421's enclosure, near the front of the unit.

Once the two standard-length brackets have been installed, the Model 5421 will be ready to be mounted onto a flat surface. Secure the unit to the surface using two mounting screws per side.

### **Left- or Right-Side Rack Mounting One Model 5421 Unit**

Installation kit RMBK-11 allows one Model 5421 to be mounted in the left or right side of one space (1U) of a standard 19-inch rack enclosure. The kit contains one standard-length bracket, one long-length bracket, and four 6-32 thread-pitch Phillips-head machine screws. Refer to Appendix C for a visual explanation.

Begin the installation by removing the four screw-on rubber feet from the bottom of the Model 5421's chassis. They can be removed using one's fingers to rotate them counterclockwise; no tool is required. Store the feet for possible later use.

With assistance from a #2 Phillips-tip screw driver, use the machine screws to attach the standard and long rack brackets to the sides of the Model 5421's enclosure. The screws will mate with the threaded fasteners that can be seen on the sides of the Model 5421's enclosure, near the front of the unit.

Mount the standard rack bracket to the left side of the Model 5421 (when viewed from the front) if the unit needs to be located on the left side of the rack enclosure. Then mount the long rack bracket to the right side of the Model 5421. Mount the brackets in the opposite orientation should the Model 5421 need to be located on the right side of the rack enclosure.

Once the standard and long rack brackets have been installed, the Model 5421 will be ready to be mounted into the designated equipment rack. One space (1U or 1.75 vertical inches) in a standard 19-inch equipment rack is required. Secure the unit into the equipment rack using two mounting screws per side.

### **Rack-Mounting Two Model 5421 Units**

Rack-mount installation kit RMBK-12 is used to allow one-space (1U) rack mounting of two Model 5421 units. The kit can also be used to mount one Model 5421 and another product that is compatible with the RMBK-12 (such as the Studio Technologies' Model 48D Dante Bridge). The kit contains two standard rack brackets, two joiner plates, eight 6-32 thread-pitch Phillips-head machine screws, and two 2-56 thread-pitch Torx T7 thread-forming machine screws. Refer to Appendix D for a visual explanation.

Begin installing the kit by removing the four screw-on rubber feet from the bottom of each chassis. They can be removed using one's fingers to rotate them counterclockwise; no tool is required. Store the feet for possible later use.

With assistance from a #2 Phillips-tip screw driver, use two of the 6-32 machine screws to attach one of the standard rack brackets to the left side (when viewed from the front) of one of the Model 5421 units. Using two more of the 6-32 machine screws, attach one of the joiner plates to the right side of that same Model 5421 unit. The screws will mate with the threaded fasteners that can be seen on the sides of the Model 5421's enclosure, near the front of the unit.

Again using two of the 6-32 machine screws, attach the second standard rack bracket to the right side of the second Model 5421 or other compatible unit. Using the final two 6-32 machine screws, attach the second joiner plate to the left side of the second Model 5421 or other compatible unit with an orientation of 180 degrees from the way in which the first plate was installed.

To complete the assembly, "join" the units together by sliding each joiner plate through the other. The grooves in each joiner plate will carefully align with each other and form a relatively tight bond. Line up the two units so that the front panels form a common plane. With the aid of a Torx T7 driver, use the two 2-56 machine screws to secure the two joiner plates together. The screws should fit snugly into the small openings formed by the mating of the two joiner plates.

Once the 2-unit assembly is created, it is ready to be mounted into the designated equipment rack. One space (1U or 1.75 vertical inches) in a standard 19-inch equipment rack is required. Secure the assembly into the equipment rack using two mounting screws per side.

## Center Rack Mounting One Model 5421 Unit

Installation kit RMBK-13 allows one Model 5421 to be mounted in the center of one space (1U) of a standard 19-inch rack enclosure. The kit contains two medium-length brackets and four 6-32 thread-pitch Phillips-head machine screws. Refer to Appendix E for a visual explanation.

Begin the installation by removing the four screw-on rubber feet from the bottom of the Model 5421's chassis. They can be removed using one's fingers to rotate them counterclockwise; no tool is required. Store the feet for possible later use.

To prepare the unit to mount in the center of a rack enclosure, use a #2 Phillips screwdriver and two 6-32 machine screws to attach one of the medium-length brackets onto the left side (when viewed from the front) of the enclosure. Using two additional 6-32 machine screws, attach the other medium-length bracket onto the right side of the Model 5421's enclosure. The screws will mate with the threaded fasteners that can be seen on the sides of the Model 5421's enclosure, near the front of the unit.

Once the two medium-length brackets have been installed, the Model 5421 will be ready to be mounted into the designated equipment rack. One space (1U or 1.75 vertical inches) in a standard 19-inch equipment rack is required. Secure the unit into the equipment rack using two mounting screws per side.

## Dante Configuration

For audio to correctly pass to and from the Model 5421 requires that, at a minimum, several Dante-related parameters be configured. These configuration settings will be stored in non-volatile memory within the Model 5421's circuitry. Configuration will typically be done with the Dante Controller software application which is available for download free of charge at [audinate.com](http://audinate.com). Versions of Dante Controller are available to support Windows® and macOS® operating systems. The Model 5421 uses the Broadway integrated circuit to implement the Dante functionality. The Model 5421 is compatible with the Dante Domain Manager (DDM) software application. This may allow ST 2110-30 routes to be established to and from the Model 5421's audio channels.

## Unit and Channel Names

The Model 5421 has a default Dante device name of **ST-M5421-** along with a unique suffix. The suffix identifies the specific Model 5421 that is being configured. The suffix's actual alpha and/or numeric characters relate to the MAC address of the unit's Broadway integrated circuit. By default, the 16 Dante receiver (input) and 16 Dante transmitter (output) audio channels are organized as two 8-channel groups. The channel default names are **A01-Group A** through **A08-Group A** and **B01-Group B** through **B08-Group B**. Using the Dante Controller application, the default device name and channel names can be revised as appropriate for the specific application.

## Sample Rate, Encoding, Clocking, and Latency

The Model 5421 only supports an audio sample rate of 48 kHz with no pull-up/pull-down values available. Encoding choices are *PCM 24*, *PCM 16*, and *PCM 32*, but in virtually all cases the default selection of PCM 24 would be appropriate. This is due to the processing within the Model 5421 being performed in 24-bit. Device Latency can be adjusted if required but the default value of 1.0 msec will typically be correct.

## Network Configuration – Addresses

By default, the Model 5421's Dante IP address and related network parameters will be determined automatically using the DHCP protocol or, if not available as a network resource, the link-local protocol. If desired, Dante Controller allows the Model 5421's IP address and related network parameters to be manually set to a fixed (static) configuration. While this is a more-involved process than simply letting DHCP or link-local “do their thing,” if fixed addressing is necessary then this capability is available. In this case, it's highly recommended that a unit be physically marked, e.g., directly using a permanent marker and “console tape,” noting its specific static IP address. If knowledge of a Model 5421's IP address has been misplaced there is no reset button or other simple method to identify and restore the unit to a default IP setting. Refer to the Technical Notes section for additional details.

## **AES67 Configuration – AES67 Mode**

Using Dante Controller, the Model 5421 can be configured for AES67 operation. This requires that the AES67 Mode configuration choice to be set for Enabled. By default, the Model 5421 has this mode configured for Disabled.

### **Clocking**

As is the case for all Dante devices, the Model 5421 can serve as a Leader clock for a Dante network. In many cases, the unit will receive “sync” from another device that’s been selected as the “primary leader” for the application. As such, the check box for Preferred Leader associated with the Model 5421 would typically not be enabled. For supporting a small- to medium-sized set of Dante devices, there’s no reason why the Model 5421 couldn’t perform admirably as a Leader clock. In this case, checking the box for Preferred Leader would be appropriate.

### **Audio Routing**

Each Model 5421 Dante transmitter (output) channel associated with a channel in an intercom group must be routed (subscribed) to the desired receiver (input) channel on an associated piece of equipment. The receiver (input) channel associated with the same channel in the same intercom group must also be routed (subscribed) to that same piece of equipment. One transmitter (output) channel and one receiver (input) channel always create a transmitter/receiver pair that is used as one channel in a party-line (PL) group. Refer to Appendix F for an example of Model 5421 routes (subscriptions) made using Dante Controller.

The most common Model 5421 configuration error occurs when the transmitter/receiver pair is not correctly routed: as a pair, to the same specific device and channel on the device. An intercom user device, such as a beltpack from Studio Technologies, must have a talk and listen channel from the same channel routed to the same channel on the same intercom group from the Model 5421.

It’s not necessary to route signals to and from all transmitter and receiver channels on a Model 5421 intercom group. There’s no problem if channels are left as “spares” for future use. It is important to remember that channels in a group always consist of a transmitter/receiver pair.

### **Flows**

The number of receiver flows associated with the Model 5421’s Broadway integrated circuit is 16. The same applies to the number of transmitter flows. Each flow can either be unicast, multicast, or a combination of the two. No receiver flow limitation will ever exist as there’s one flow available for each of the 16 receiver channels. In most cases, 16 transmitter flows should prevent an issue of insufficient transmitter from occurring. When a Model 5421 is operating in the AES67 mode, the transmitter (output) channels will always function in multicast. In AES67, unicast is not supported.

Note that within Dante Controller a “subscription” is the term used for routing a transmitter flow (a group of output channels) to a receiver flow (a group of input channels).

## Model 5421 Configuration

The Studio Technologies' STcontroller software application is used to configure the way in which the Model 5421 functions. No web pages or physical switch settings are used to configure the unit. This makes it imperative that STcontroller be available for convenient use on a personal computer that's connected to the related LAN.

### Installing STcontroller

STcontroller is required to fully support the Model 5421. It is available free of charge on the Studio Technologies' website ([studio-tech.com/stcontroller-application/](http://studio-tech.com/stcontroller-application/)) and is compatible with personal computers running Windows operating systems that are version 7 and later. If required, download and install STcontroller onto a designated personal computer. This personal computer must be on the same local area network (LAN) and subnet as the Model 5421 unit that is to be configured. Immediately after starting STcontroller, the application will locate all the Studio Technologies' devices that it can control. The one or more Model 5421 units to be configured will appear in the device list. Use the Identify command to allow easy recognition of a specific Model 5421 unit. Double-clicking on a device name will cause the associated configuration menu to appear. Review the current configuration and make any changes that are desired. The Save Configuration and Load Configuration functions allow specific profiles to be saved and then loaded into one or more units as necessary.

Using STcontroller's demo mode is an easy means of reviewing the configuration choices available for all compatible Studio Technologies' products. The demo mode also provides the ability to create and save configuration profiles without requiring the actual units to be present. These saved configuration profiles can then be loaded into actual units when they become available on the related network.

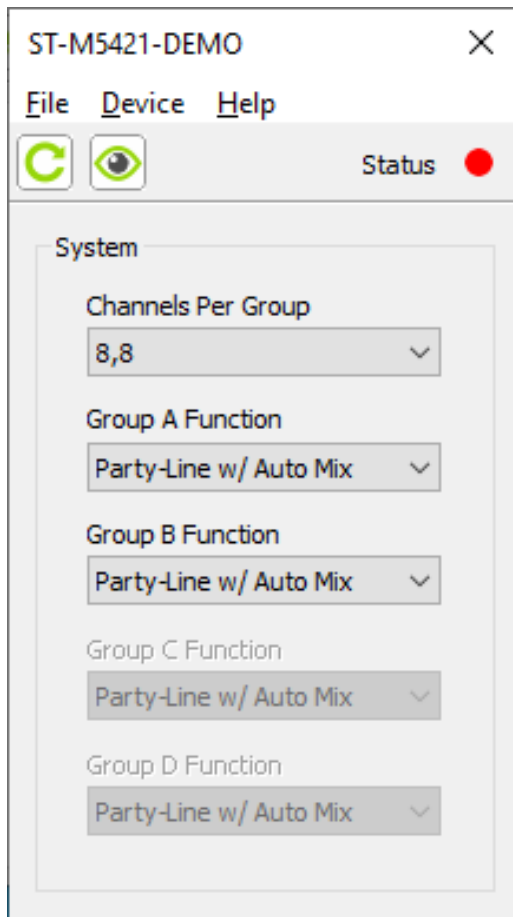

### Audio Engine Configuration

The STcontroller software application is used to configure the Model 5421's audio engines. The Model 5421's 16 Dante receiver (input) and 16 Dante transmitter (output) channels can be electronically divided to function in one of five available group arrangements. Selecting how the 16 audio engine channels are arranged into groups is crucial when working to achieve the desired Model 5421 configuration. The groups are labeled A, B, C, and D. The operating mode of each group can be individually selected. This allows the specific action of each group to be determined.

#### System – Channels per Group

The 16 channels associated with an audio engine can be configured into one of five configurations which determine the number of groups and how many channels are contained in each group.

Choices are:

- 16,
- 12, 4
- 8, 8
- 8, 4, 4
- 4, 4, 4, 4

As has been previously discussed, the Model 5421's audio engine consists of 16 Dante receiver (input) and 16 Dante transmitter (output) channels. These channel "pairs" can be configured to function in one of the five available group arrangements. As should be evident, adding together the size of each group will always equal 16. Each group will have a unique label and can be independently configured as to how it will function.

When contemplating changing the Channels per Group configuration, it's important to note two things. The first is that some or all of the Dante channel labels of each group member may automatically change to reflect the revised audio engine configuration. The second issue that could arise is that some or all of the existing Dante audio channel routes (Dante subscriptions) associated with group members will probably be deleted upon a change to the number of Channels per Group configuration. This is simply the result of Dante technology using the channel labels for identifying and establishing routes (Dante subscriptions). A route (Dante subscription) would no longer be valid if an associated channel label has been changed.

The fact that Dante transmitter (output) channel labels may automatically change when the Channels per Group configuration changes is not necessarily a bad thing. However, some editing of the channel labels (names) may be required to achieve the desired implementation. Deleting routes (Dante subscriptions) to and from group-member channels will definitely add some extra effort. Routes (Dante subscriptions) will have to be re-established once a new Channels per Group configuration has been selected and confirmed. Again, this is not a terrible thing to have occur. But it's possible that up to 32 routes (Dante subscriptions), consisting of 16 receiver/transmitter pairs, may have to be re-established.

In conclusion, a change of Channels per Group organization may be destructive as far as channel labels (names) and routes (Dante subscriptions) are concerned. Any changes made to a Channels per Group configuration is "one way" with no method to automatically return to a previous configuration. A change will require that time and effort be spent confirming and possibly revising channel labels (names) and routes (Dante subscriptions).

The identification letter used in group A of the audio engine associated with the Model 5421's will always start with the letter A. The next group will take on the next alphabetical letter. If an audio engine is configured for three groups (such as 12, 4, 4) then the group identification letters will be A, B, and C. If an audio engine is selected for four groups (4, 4, 4, 4) then the letters in the identification range will be A through D.

Within the Model 5421's logic circuitry the audio data associated with each group is fully isolated, ensuring that there will never be audio crosstalk between groups. This is to be expected since all Model 5421 Dante receiver (input) channels, Dante transmitter (output) channels, and processing is performed within the digital domain.

### **Group Label**

Associated with each group is a label (name) consisting of up to 14 alphabetic or numeric characters. The default label for each group is somewhat generic but can be revised to be more descriptive. The Dante Controller application is used to revise the labels (names). There's no reason why a human-readable label can't be used to make the function served by each group more clear. Using labels such as MainPL, ProductionComs, or Maintenance can be effectively utilized. Assigning logical, understandable labels can make long-term application maintenance much easier to perform.

## Operating Mode

Each group can be independently configured to operate from among five available operating modes. Choices are: *Party-Line w/Auto Mix*, *Party-Line*, *Summing Bus w/Auto Mix*, *Summing Bus*, and *Pass-Thru*.

A detailed explanation of each operating mode will be provided in the following paragraphs.

### Party-Line w/Auto Mix

This operating mode allows party-line (PL) channels or circuits to be created from Dante signals. An automatic mixing function helps improve voice signal intelligibility. This mode is not compatible with high-frequency call signals. (Refer to the Technical Notes section for more details.)

#### OPERATING MODE: PARTY-LINE W/AUTO MIX

EXAMPLE SHOWS GROUP A CONFIGURED FOR 4 CHANNELS PER GROUP WITH DEFAULT CHANNEL LABELS (MINIMUM 4, MAXIMUM 16 INPUT/OUTPUT PAIRS)

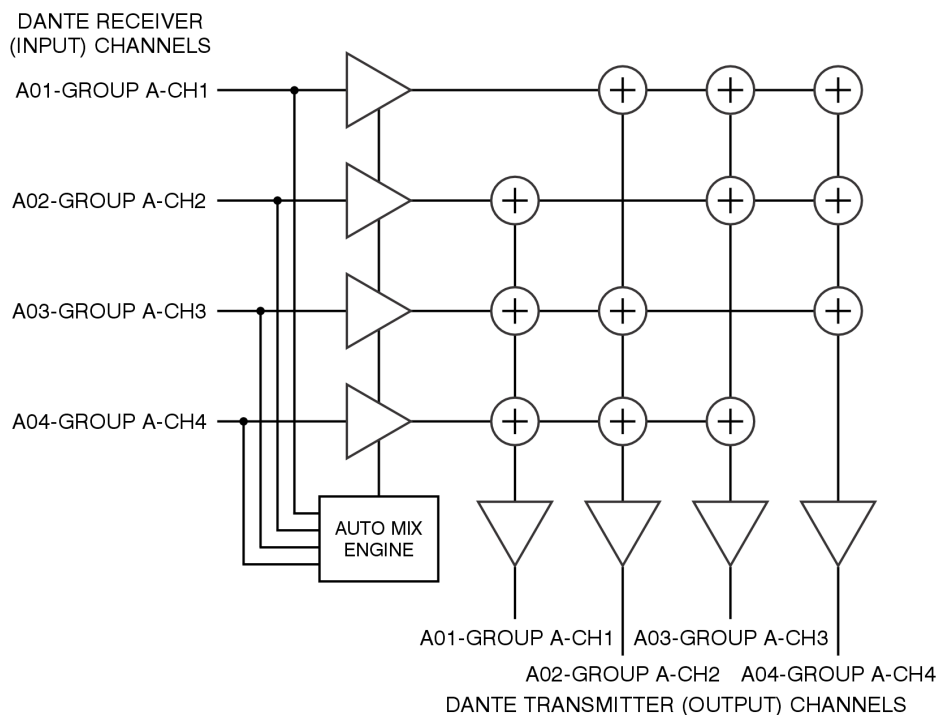

To maximize signal intelligibility, the contribution of each user's talk signal is automatically adjusted using the Auto Mix function. Unlike analog PL, Dante signals designated for intercom use can't simply be interconnected ("banged together") to form common talk/listen channels. PL functionality has to be created within digital logic to become "virtual" PL circuits. To the user the result is essentially the same; all members of a Dante PL w/Auto Mix circuit can talk and listen at the same time. How that functionality is created is quite different. As one would expect, all Dante receiver (input) and Dante transmitter (output) channels are independent. In the broadcast or legacy telephony-

world, these signals would be considered "4-wire" with separate audio paths for send and receive. As such, they need to be connected to a specialized mixer or combiner resource to allow a virtual PL function to be created. Two signal routes (Dante subscriptions) need to be established for each PL user channel. This channel "pair" must have one signal associated with an intercom device's Dante transmitter (output) channel and a second associated with the intercom device's Dante receiver (input) channel.

The Auto Mix action that applies to this operating mode uses a special audio processing algorithm that provides enhanced audio performance for party-line (PL)

applications. This algorithm, implemented in high-speed logic within the Model 5421's FPGA integrated circuit, automatically adjusts the contribution that each audio input signal makes to the party-line group. This automatic mixing action balances the relative audio level of each input that is contributing to the party-line function. Auto Mix will also significantly reduce the contribution to the overall mix from each audio input signal if its level is determined to be below a fixed threshold. This helps ensure that users who are actively talking on a PL circuit will be clearly heard, while those who are not actively talking will have their background audio minimized.

Technically, within the Model 5421's logic circuitry, multiple line-level mix-minus audio paths (buses) are created from the Dante receiver (input) audio signals; each device that is part of a Party-Line w/Auto Mix channel or circuit requires an independent mix-minus signal. The concept is simple, each user that's part of a specific PL wants to hear an audio signal created by a Party-Line w/Auto Mix operating mode function that contains everyone but themselves. They don't want to hear themselves coming back from the Model 5421 as there could be too much or too little signal level, slight audio time delays, or other audio artifacts. They'll want to hear themselves (by way of their own microphone) but through the sidetone function that is provided by their own beltpack or intercom station.

To further explain, let's use the example of four users that are part of a 4-channel virtual PL circuit created by the Model 5421. User one wants to hear talk audio from users two, three, and four. User two wants to hear talk audio from users one, three, and four. User three wants to hear talk audio from users one, two, and four. And user four wants to hear talk audio from users one, two, and three. To support these four users requires that the Model 5421 create four unique mix-minus functions. This is accomplished within the unit's digital logic circuitry. Four associated Auto Mix functions help to ensure that the audio that each user receives is uniformly excellent. And finally, for each user to hear themselves (audio associated with their own microphone) each intercom device (typically a beltpack or intercom station) will have an integrated sidetone function.

To summarize, each member of a Party-Line w/Auto Mix group is assigned its own mix-minus channel, meaning that the audio that it supplies to the group

is routed to all other members of the group but not returned to itself. A user receives confirmation audio from their own microphone by way of its local sidetone function and not from the group's mixing and distribution functions that create the multiple mix-minus buses.

The number of channels in a group that is configured for Party-Line w/Auto Mix operation defines the maximum number of Dante device talk/listen channels that can join together to form a virtual party-line (PL). The Model 5421's configuration choices range from a single 16-channel PL circuit, to four 4-channel groups. What configuration choice is optimal for an application will depend on the maximum number of independent PL "circuits" that need to be established. A simple review of an application should lead to the desired group configuration.

While the maximum number of talk/listen channels that can be assigned to a group is defined by the group size, this does not mean that all channels associated with a group have to be utilized. For example, if a Model 5421 is configured to provide two groups of eight channels each, the first group could have six talk/listen channel pairs routed to it while the second group could have just three talk/listen channel pairs routed to it. The unused channel pairs in each group, two and five respectively in our example, don't contribute any noise or audio artifacts. They are simply "spares" and available for future use, allowing additional talk/listen channel pairs to be routed to them as needed. Groups are just resources that allow talk/listen channel pairs on compatible devices to be linked together. A group size just defines the maximum number of device channel pairs that can be part of a set of users that can talk and listen among themselves.

As an example, if one group of 16 channels is selected then a maximum number of 16 talk/listen channel pairs from Dante-compatible devices can be routed (Dante subscribed) to it. This would, as an example, allow up to 16 of the Studio Technologies' Model 372A or Model 373A single-channel beltpacks to be utilized together in what for the users would be a party-line (PL) or shared communication channel or circuit. If, as another example, an application requires that eight of the 2-channel Model 370A or Model 371A beltpacks need to function together to support two independent party-line (PL) channels, then configuring a Model 5421 for two 8-channel groups would be appropriate.

When deploying a Party-Line w/Auto Mix circuit, it's important to note that two Dante channels are associated with each channel of a Model 5421 group. The Dante transmitter (output) channel of an intercom device will be routed (Dante subscribed) to a Dante receiver (input) channel on a group that has been configured for Party-Line w/Audio Mix operation. The specific Dante transmitter (output) channel associated with that group must be routed back to the listen input on that specific intercom device. For example, if Dante transmitter (output) channel one of a Studio Technologies' Model 371A beltpack is routed to input 02 of a Model 5421 Party-Line w/Auto Null group, then that group's output 02 must be routed to the receiver (input) of channel one of the Model 370A. Output 02 from the Model 5421 would be the mix-minus signal that channel one of this specific Model 371A would require for correct operation; no other device should utilize Model 5421 output 02.

For clarity, for correct Party Line w/Auto Null operation to take place one, and only one, pair of channels (one "talk" and one "listen") from an intercom user device must be routed (Dante subscribed) to one pair of channels (one "listen" and one "talk") on a channel associated with a Model 5421 Party-Line w/Auto Null group. These routes must be made to associated channel pairs on both the Dante beltpack or intercom station devices and the Model 5421 Party-Line w/Auto Mix channels.

Party-line (PL) channel routing (Dante subscribing) is the main area of confusion when users first encounter a Model 5421. After some study and experimentation the process should become clear. It's important to remember that when associating an intercom device to a PL channel on a Model 5421 Party Line w/Auto Mix group always involves routing (Dante subscribing) two channels. Two routes (Dante subscriptions) will always be made to add an intercom channel to a Model 5421 Party Line w/Auto Mix group. A Dante transmitter (output) channel that has "talk" audio from the intercom device needs to be routed to an input on a Party-Line w/Auto Mix group. The associated Dante transmitter (output) channel on the same Party Line w/Auto Mix group (the specific mix-minus output) needs to be routed to the input on that specific intercom device. Without routing both channels, PL functionality will not be achieved.

Another suggestion is that unless one is experienced with how the Model 5421 creates a party line, start by creating a small implementation. Don't try to route (Dante subscribe) a large number of channels or user devices at one time. The complexity will make it very difficult to achieve the desired result. Begin by creating the world's smallest PL intercom circuit. Just link a single channel between two user devices. Experiment with the sidetone function on each of the two user devices. Turn off sidetone in the user devices and ensure that each user device is really getting a "mix-minus" — each user should hear the other but not itself. Then set sidetone on the user devices to the desired level. Get that functioning correctly and you'll understand the basics. Only then move on to adding additional user devices. Spending an hour or two experimenting with these topics will help you to fully understand what's going on. From there you'll be ready to implement whatever your final application requires.

The Party-Line w/Auto Mix mode is not compatible with high-frequency call signals. Refer to the Technical Notes section for details.

## Party-Line

This operating mode is identical to the Party-Line w/Auto Mix operating mode with the exception that the Auto Mix function is not active. Studio Technologies recommends that in most cases the Auto Mix function be active. For special applications or test purposes, this mode might be appropriate. Refer to the previous section for details on party-line operation.

### OPERATING MODE: PARTY-LINE

EXAMPLE SHOWS GROUP A CONFIGURED FOR 4 CHANNELS PER GROUP WITH DEFAULT CHANNEL LABELS (MINIMUM 4, MAXIMUM 16 INPUT/OUTPUT PAIRS)

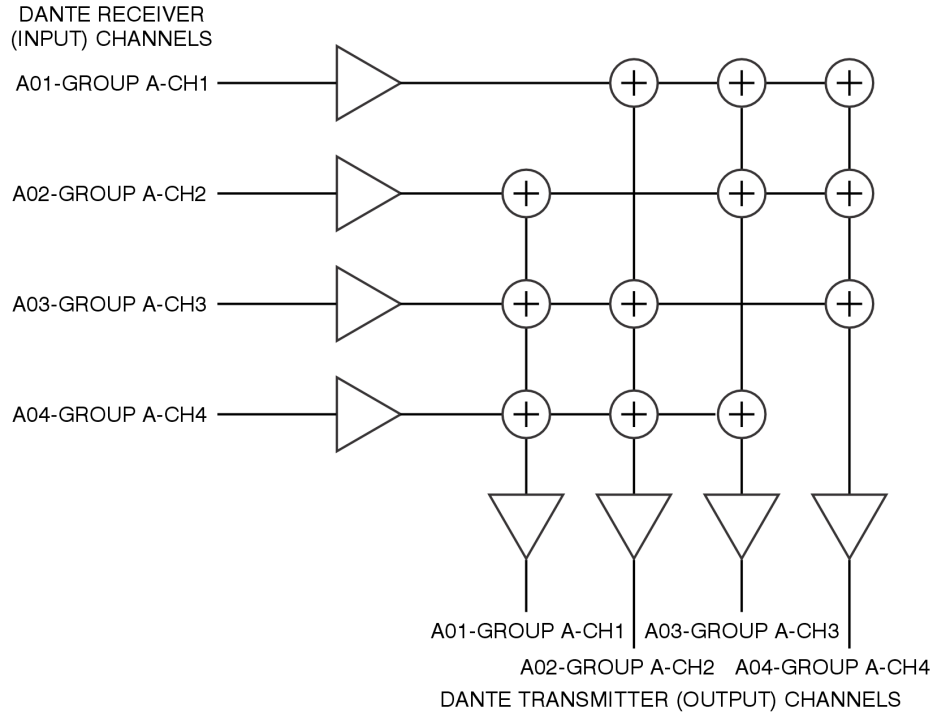

## Summing Bus w/Auto Mix

This operating mode allows two or more Dante receiver (input) audio signals to be summed (combined, mixed, or added). This mode can be considered as implementing a “unity” gain mixing amplifier or “mix bus” function; no gain adjustment of any input or output channels is provided. The resulting signal mix is output by way of multiple Dante transmitter (output) channels. To maximize signal intelligibility, the contribution (level) of each input signal is automatically adjusted using the Auto Mix function. This function is implemented within the Model 5421’s programmable logic as was discussed in previous sections.

### OPERATING MODE: SUMMING BUS W/AUTO MIX

EXAMPLE SHOWS GROUP A CONFIGURED FOR 4 CHANNELS PER GROUP WITH DEFAULT CHANNEL LABELS (MINIMUM 4, MAXIMUM 16 INPUT/OUTPUT PAIRS)

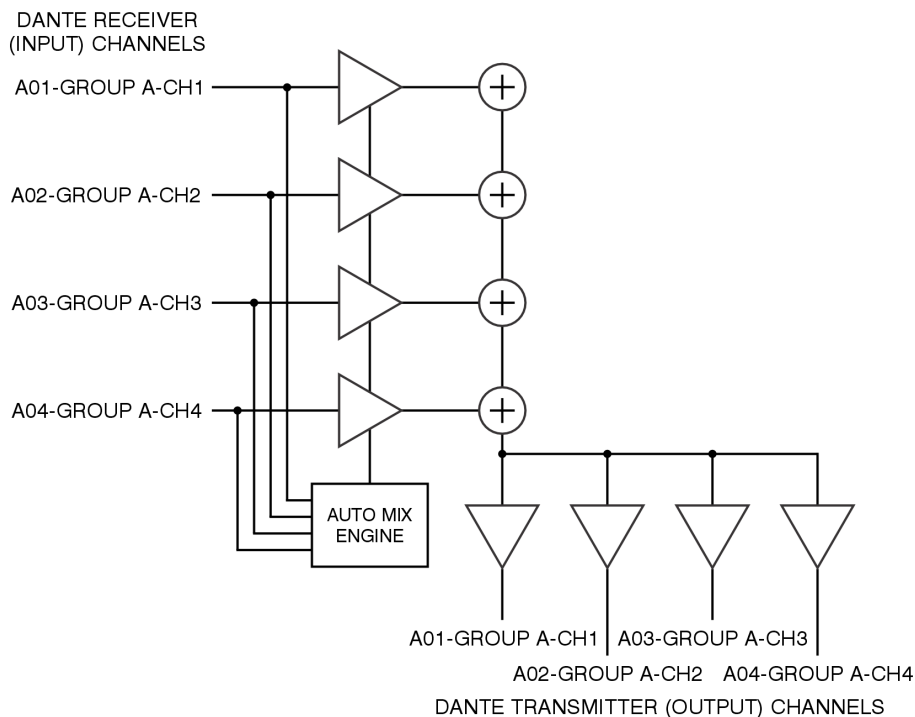

One Summing Bus w/Auto Mix section can be configured as active for each Model 5421 group. As such, the number of input and output channels depends on the selected group size. A group size of 4 would provide four Dante receiver (input) channels. These channels would be combined and output by way of four Dante transmitter (output) channels. A group size of 16 would provide 16 Dante receiver (input) channels whose signals would combine and be output on all 16 Dante transmitter (output) channels.

Any one of the group’s outputs can be routed (Dante subscribed) to multiple Dante receivers (inputs) on associated equipment. Or a group function’s multiple outputs can be routed (Dante subscribed) to the one or more Dante receivers (inputs) on multiple products.

The overall connection limitation is really the number of supported Dante flows, which in the case of the Model 5421 is 16 in each direction. (In most cases, a Dante flow will consist of a connection that supports up to four audio channels.)

The Summing Bus w/Auto Mix operating mode can be useful for a variety of on-air, IFB-related (talent cueing), production, and general-audio applications. With the inclusion of Auto Mix functionality this operating mode can make the Model 5421 an important part of an application that needs a means of combining multiple audio sources with automatic control over the overall “mix.” To achieve this has, in the past, typically required the use of a stand-alone audio processor, portable analog-supporting mixer unit, or digital plug-in.

## Summing Bus

This operating mode allows Dante receiver (input) audio signals to be summed (combined, mixed, or added). This mode can be considered as implementing a “unity” gain mixing amplifier or “mix bus” function; no signal level adjustment is possible. The resulting output signal is provided on multiple Dante transmitter (output) channels. This mode is identical to the Summing Bus w/Auto Mix operating mode with the exception that the Auto Mix function is not active.

### OPERATING MODE: SUMMING BUS

EXAMPLE SHOWS GROUP A CONFIGURED FOR 4 CHANNELS PER GROUP WITH DEFAULT CHANNEL LABELS (MINIMUM 4, MAXIMUM 16 INPUT/OUTPUT PAIRS)

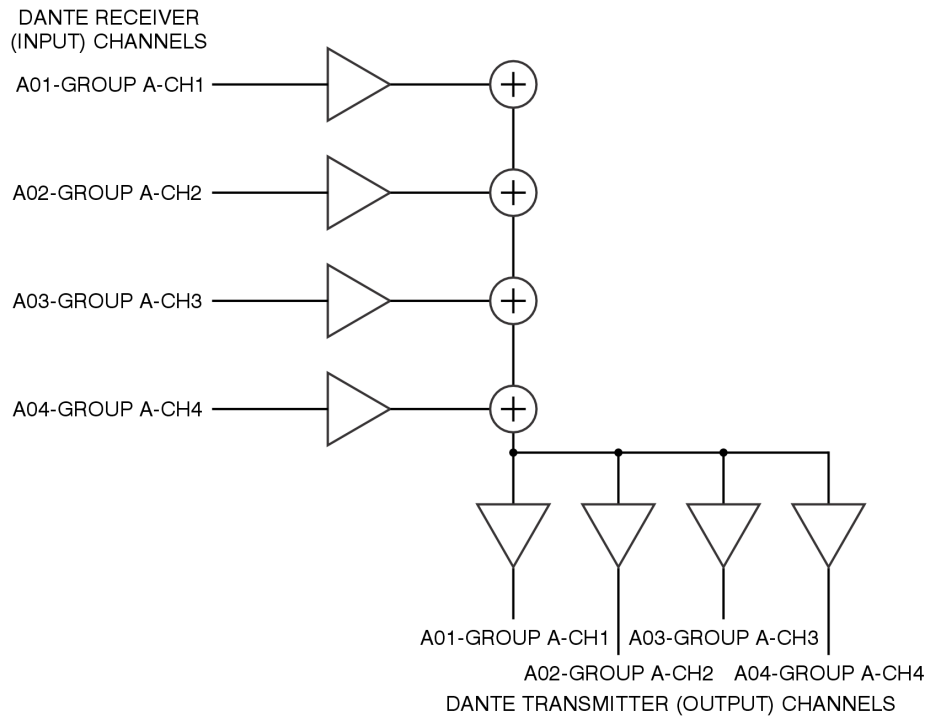

## Pass-Thru

This operating mode allows one Dante receiver (input) audio signal to be routed directly to a corresponding Dante transmitter (output) channel. The same audio data that arrives on the receiver (input) channel is sent to the transmitter (output) channel; nothing is added or removed. The Pass-Thru operating mode is primarily provided as a Dante flow “expander.” (A Dante flow is typically a group of up to four audio channels that are connected from one Dante-compatible device to another. All Dante devices support a fixed number of flows, some as low as four while others have 32 or even more.) The Pass-Thru operating mode can also be useful for interfacing Dante transmitter (output) channels that are not compatible with the Dante Domain Manager (DDM) application with Dante receiver (input) channels that do require DDM compatibility. (All Model 5421 Dante connections are DDM compatible.)

### OPERATING MODE: PASS-THRU

EXAMPLE SHOWS GROUP A CONFIGURED FOR 4 CHANNELS PER GROUP WITH  
DEFAULT CHANNEL LABELS (MINIMUM 4, MAXIMUM 32 INPUT/OUTPUT PAIRS)

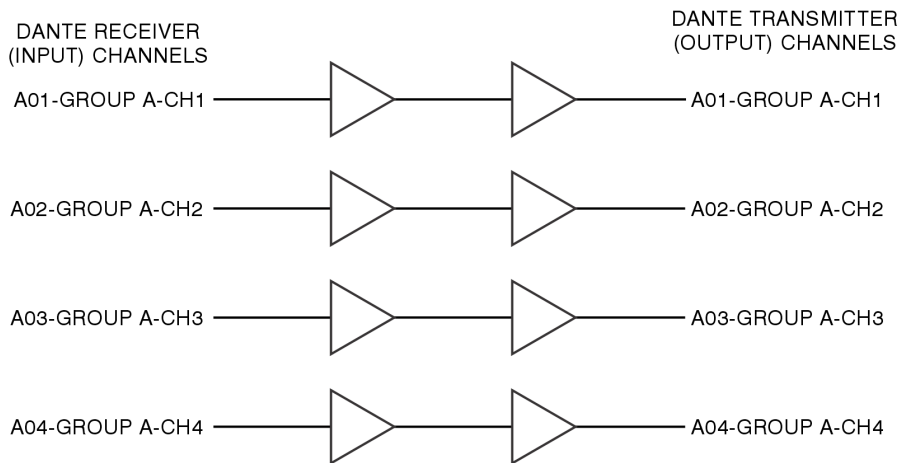

Dante interfaces, such as ones that utilize the popular 2-in/2-out or 4-in/4-out Ultimo™ integrated circuit, are limited to just four flows, two in each direction. This will restrict the number of destinations that a Dante transmitter (output) channel associated with an Ultimo-based interface that can be routed (Dante subscribed) to a maximum of two. The Model 5421 uses Audinate’s Broadway integrated circuit to implement its Dante interface. This integrated circuit supports a maximum of 32 Dante flows, 16 in each direction. As such, using the Model 5421’s Pass-Thru operating mode would allow flow-limited devices to take advantage of the Model 5421’s larger flow resources. In the broadcast world, the Pass-Thru operating mode can be considered to be a special Dante flow “distribution amplifier” function.

A practical application would be to allow the Dante transmitter (output) channels provided by Studio Technologies’ products that utilize the Ultimo integrated

circuit to interconnect with more than two devices. For example, the popular Model 204/205/206-series of announcer’s console units utilize Ultimo integrated circuits to implement their Dante interfaces. As such, Dante transmitter (output) channels associated with these announcer’s consoles can only be routed (Dante subscribed) to two unique destinations. This can be a problem for some applications, especially with the 4-channel Model 206. However, a solution to this flow limitation is quite simple to achieve. By first routing (Dante subscribing) these Dante transmitter (output) channels through sections associated with the Model 5421’s Pass-Thru operating mode the number of flows is now much greater. The flow limitation that was two has now been “expanded” to the Model 5421’s 16! The audio signals from the announcer’s consoles can now be routed (Dante subscribed) to as many destinations as is practically required.

Each Pass-Thru section uses one Dante receiver (input) channel and one Dante transmitter (output) channel. The number of Pass-Thru sections provided by a Model 5421 group depends on the selected group size. A group size of 4 would provide four independent Pass-Thru sections. A group size of 16 would provide 16 independent Pass-Thru sections.

## Operation

At this point, the Model 5421 should have a GigE PoE Ethernet connection made to the network interface jack. Using the STcontroller software application, the configuration parameters should have been reviewed and selected as desired. The Dante Controller software application allowed the network-related configuration settings to have been made. This included enabling AES67 support if needed. The Dante transmitter (output) and receiver (input) channel pairs should have been routed (subscribed) to create the desired party-line intercom virtual circuits.

### Initial Operation

Typically, a Model 5421 will begin functioning within approximately 30 seconds of its Power-over-Ethernet (PoE) power source being connected. The two status LEDs that are part of the RJ45 jack have the names LINK and ACT. The LINK LED is orange and will light when a network connection has been established. The ACT LED is green and will flash whenever Ethernet data is passing through the interface.

Upon power being connected, the Model 5421's micro-processor will start to function and initiate an LED test sequence. This will cause the green LED associated with the USB receptacle on the back panel to flash once. In addition, the two bi-color LEDs on the front panel, labeled SYS and SYNC, will first light green then red, to indicate that they are functional. After a few more seconds, they will commence normal operation, reporting on the status of the associated Dante network. Both the SYS and SYNC LEDs will light red when their associated functions are not operational.

### Dante Status LEDs

On the front panel, the user is presented with two status LEDs. These resources are simple to understand and should prove to be useful during operation and troubleshooting. The SYNC LED will light red when the Ethernet interface is not synchronized with the Dante network. It will light solid green when the Ethernet interface is fully synchronized with the connected Dante network and an external clock source (timing reference) is being received. The SYNC LED will slowly flash green if the Model 5421's Dante interface is serving as the Leader clock for the connected Dante network.

## How to Identify a Specific Model 5421

The Dante Controller and STcontroller software applications offer an Identify command that can be used to help locate a specific Model 5421 device. When the *Identify* command is selected, the SYS and SYNC LEDs on the front panel will flash green. After a few seconds, the identification patterns will cease and normal Model 5421 LED operation will resume. Audio performance will not be impacted by the use of the Identify command. As such, it's perfectly acceptable to use this command at any time.

### Normal Operation

Normal operation should find the Dante status LEDs on the front panel lit. SYS should be solid green. SYNC should be solid green if an external clock source is providing timing. It will slowly flash green if the unit is serving as Dante Leader clock. The Model 5421 is designed for continuous operation. It uses low-power circuitry, consuming about 4 watts under normal conditions. No regular maintenance is required.

The STcontroller application is used to make any required configuration changes. It can also be used to find detailed information about the Model 5421's firmware (embedded software) and Dante interface. Application firmware updates will be made using the USB receptacle on the back panel. Dante interface firmware updates will be performed using the Ethernet connection. Details regarding firmware updates are provided later in this guide.

## Technical Notes

### Using a Group for Digital Mixing Purposes

A Model 5421 group creates party-line (PL) circuits which are actually a set of mix-minus buses, one per group member. Group sizes can range from four to 16 channels. So, as an example, a group size of eight will have eight mix-minus buses. The Model 5421 can be used as a general-purpose Dante unity-gain mixing device but with one limitation. The number of input signals allowed to be routed to the mix "bus" must be one less than the size of the group. This is because the group's channel used as the mix output must not have an input signal associated with it. Otherwise, that input won't be present in the mix. (Remember, the Model

5421 creates mix-minus buses; each output has everything but its associated input!) In practice, this means that by selecting different group size configurations the Model 5421 can be used as 15-, 11-, 7-, or 3-channel digital mixers. No input signal can be assigned to a group's channel that's being used as the output.

Users who are familiar with the Studio Technologies' Model 5422A Dante Intercom Audio Engine may recall that each of the unit's groups can be independently configured for a number of modes including intercom, IFB, and summing bus. The summing bus mode allows all channels of a group to be used for a mixing function. The Model 5421, as a more modest product, offers only intercom groups. Simply using one channel of a group as an output allows a mix function to be established.

Depending on the application, the Auto Mix function may – or may not – be useful. In some situations, the Auto Mix function will be of sufficient importance to make it valid to use a Model 5421 just for this resource. Using it for general-purpose audio applications, and not just for intercom, may prove to be valuable.

## IP Address Assignment

By default, the Model 5421's Ethernet interface will attempt to automatically obtain an IP address and associated settings using DHCP (Dynamic Host Configuration Protocol). If a DHCP server is not detected, an IP address will automatically be assigned using the link-local protocol. This protocol is known in the Microsoft® world as Automatic Private IP Addressing (APIPA). It is also sometimes referred to as auto-IP (PIPPA). Link-local will randomly assign a unique IP address in the IPv4 range of 169.254.0.1 to 169.254.255.254. In this way, multiple Dante-enabled devices can be connected together and automatically function, whether or not a DHCP server is active on the LAN. Even two Dante-enabled devices that are directly interconnected using an RJ45 patch cord should correctly acquire IP addresses and be able to communicate with each other.

As previously discussed, the Model 5421's Dante IP address and related network parameters can be manually set for a fixed (static) configuration using the Dante Controller software application. In the unfortunate event that a specific Model 5421's IP address is "lost," there are several techniques that may prove useful. It's possible that the Address Resolution Protocol (ARP) networking command can be used to "probe"

devices on a network for this information. For example, in Windows OS the **arp -a** command can be used to display a list of LAN information that includes MAC addresses and corresponding IP addresses. (Within this list should be the Model 5421's statically assigned Dante IP address.) This method is most effective with a LAN that uses unmanaged Ethernet switches. Contemporary LANs that utilize managed switches may limit the ARP command's effectiveness.

In general, the simplest means of identifying an unknown IP address is to create a "mini" LAN with an unmanaged PoE-enabled Ethernet switch. Then by using the appropriate ARP command the required "clues" can be obtained. It's also possible to make an almost-direct connection between a personal computer and a Model 5421. The only additional piece of equipment required would be a PoE mid-span power supply for providing power to the Model 5421. From a data standpoint, this implementation would provide a direct connection between the two Ethernet ports.

## Optimizing Network Performance

For best Dante audio-over-Ethernet performance, a network that supports VoIP QoS (Voice-over-Internet-Protocol quality of service) capability is recommended. This can typically be implemented on virtually all contemporary managed Ethernet switches. There are even specialized switches that are optimized for entertainment-associated applications. Refer to the Audinate website ([audinate.com](http://audinate.com)) for details on how to optimize a network for Dante applications.

## Application Firmware Version Display

The STcontroller software application is used to display the version numbers of the Model 5421's two firmware (embedded software) components. These are the application firmware and the FPGA firmware. The application firmware is used by the unit's microcontroller integrated circuit to implement the Model 5421's general operating actions. The FPGA firmware is used by the field-programmable-gate-array integrated circuit which performs all audio processing functions.

To observe the firmware version numbers, begin by connecting the Model 5421's Ethernet port to a network. The unit will begin to function approximately 30 seconds after power is supplied. Start STcontroller, review the list of identified devices, and select the

specific Model 5421 from which you want to determine its firmware versions. Then select **Version** under the **Device** tab. A dialog will display that will provide a host of useful information. This will include the firmware versions as well as details on the Dante interface firmware.

## Application Firmware Update Procedure

It's possible that updated versions of the two firmware (embedded software) files that are utilized by the Model 5421's microcontroller and FPGA (field-programmable-gate-array) integrated circuit will be released to add features or correct issues. Refer to the Studio Technologies' website for the latest firmware files. The unit has the ability to load revised files into non-volatile memory by way of a standard USB flash drive. The Model 5421 implements a USB host function and provides access by way of a type A receptacle located on the unit's back panel. The Model 5421 updates its firmware using files named **M5421.bin** for the main firmware and **BWYA.bit** for the FPGA firmware.

The update process begins by preparing a USB flash drive. The flash drive doesn't have to be empty (blank) but must be in the personal-computer-standard FAT32 format. One or both of the firmware files can be automatically loaded and will be done sequentially. In the root directory, save the desired new firmware file(s), ensuring that the required name or names are specified. For the application firmware the file name must be **M5421.bin** and for the FPGA firmware the file name must be **BWYA.bit**. Studio Technologies will supply each firmware file inside a .zip archive file. While the firmware file inside of the zip file will adhere to the naming convention required by the Model 5421, the name of the zip file itself will include the file's version number. For example, a file named **M5421v2r00MCU.zip** would indicate that version 2.00 of the application firmware (**M5421.bin**) is contained within this zip file.

Once the USB flash drive is inserted into the USB type A receptacle, located on the back panel, the unit must be powered off and powered on again. At this point, the file(s) will automatically load. The precise steps required will be highlighted in the next paragraphs.

To install either or both of the firmware files follow these steps:

1. Remove power from the Model 5421 by disconnecting the Ethernet connection from the RJ45 jack on the back panel.
2. Locate the USB type A receptacle on the Model 5421's back panel, labeled Firmware Update. Directly to the right of the USB receptacle is a small hole that provides visual access to a green LED indicator.
3. Insert the prepared USB flash drive into the USB receptacle.
4. Apply power to the Model 5421 by reconnecting the Ethernet signal to the RJ45 jack.
5. After a few seconds, the Model 5421 will run a "boot loader" program that will automatically read and then save the new firmware file(s) that are present on the USB flash drive. The update process can range from approximately 15 seconds to approximately 45 seconds, depending on which files are going to be updated. While the files are being loaded the green LED, located to the right of the USB receptacle, will flash slowly. Once the loading process has completed the Model 5421 will restart using the newly saved main firmware.
6. At this time, the Model 5421 is functioning with the newly loaded firmware and the USB flash drive can be removed. To be conservative, remove the power source first and then remove the USB flash drive.
7. If necessary, restart the Model 5421 by connecting the Ethernet with PoE signal to the RJ45 jack. Confirm that the desired firmware has been loaded and that the Model 5421's two firmware files are as desired. This is accomplished using the STcontroller software application. (Use the **Version** selection under the **Device** tab.)

Note that upon power being applied to the Model 5421, if the USB flash drive doesn't have the correct file(s) in its root folder no harm will occur. Upon power up, the green LED, located below the USB receptacle, will flash on and off rapidly for a few seconds to indicate that a valid file has not been found. After this indicating sequence has completed, normal operation using the unit's existing application and FPGA firmware will begin.

## Broadway Firmware Update

As previously discussed, the Model 5421 implements Dante connectivity using the Broadway integrated circuit from Audinate. The STcontroller software application can be used to identify the Dante firmware version. (Use the **Version** selection under the **Device** tab.)

The firmware (embedded software) residing in Broadway can be updated using the Model 5421's Ethernet port. Performing the update process is easily accomplished using an automated method called Dante Updater that's included as part of the Dante Controller application. This application is available, free of charge, from the Audinate website (audinate.com). The latest Model 5421 firmware file, with a name in the form of **M5421vXrXrX.dnt**, is always available on the Studio Technologies' website as well as being part of Audinate's product library database. The latter allows the Dante Updater software application that is included with Dante Controller to automatically query and, if required, update the Model 5421's Dante interface.

## Restoring Factory Defaults

A command in the STcontroller software application allows the Model 5421's configuration selections to be reset to the factory values. From STcontroller, select the Model 5421 for which you want to restore its defaults. Select the **Device** tab and then select the **Factory Defaults** feature. Then click on the **OK** box. Refer to Appendix A for a list of the Model 5421's factory defaults.

## Call Signals and Party-Line w/Auto Mix Mode

The Party-Line w/Auto Mix mode is not compatible with applications that need to utilize high-frequency call signals. The level of these call signals, typically sine waves at a frequency of 20 kHz, will be impacted by the automatic mixing action. Technically, a party-line (PL) channel that is not actively selected as the "talker" by the Auto Mix firmware will have its broadband audio level attenuated. This is the normal action of the Auto Mix function but, of course, will impact both voice band and high-frequency call signals. Attenuation of the voice band signals is desired but attenuation of the call signals will prevent devices from receiving the call signals at a sufficient level to cause call activation. If compatibility with high-frequency call signals is desired then the Party-Line mode should be selected.

## Specifications

**Applications:** Designed to create multiple party-line (PL) circuits in Dante audio-over-IP environments. Also provides functions for use in Remote Integration (REMI) and At-Home production applications. Includes summing (mixing) of audio channels for general-purpose applications. Special Dante pass-thru mode allows flow-limited and non-AES67-compliant Dante devices to participate in more-advanced applications. Auto Mix capability is available for use in party-line and summing operating modes.

**Engine Group Options:** the following group sizes can be selected:

- 16 (one group)
- 12, 4 (two groups)
- 8, 8 (two groups)
- 8, 4, 4 (three groups)
- 4, 4, 4, 4 (four groups)

### **Audio Performance:**

**Internal Digital Audio Processing:** 24-bit, fixed

**Input-to-Output Audio Processing Latency:**  
<100 uSec

**Auto Mix:** sophisticated FPGA-based algorithm provides enhanced party-line (PL) audio intelligibility (selectable on or off)

### **Network Audio Technology:**

**Type:** Dante audio-over-Ethernet (also known as Dante audio-over-IP)

**AES67-2018 Support:** yes

**Dante Domain Manager (DDM) Support:** yes

**Clock Source:** Dante network or internal (can serve as Leader clock)

**Bit Depth:** 16, 24, or 32

**Sample Rate:** 48 kHz

**Number of Dante Receiver (Input) Channels:** 16

**Number of Dante Transmitter (Output) Channels:** 16

**Number of Dante Flows:** 16 receiver, 16 transmitter

### **Network Interface:**

**Type:** 1000BASE-T (Gigabit, GigE, or GbE) per IEEE 802.3ab, twisted-pair Ethernet, Power-over-Ethernet (PoE) supported

**Data Rate:** 1000 Mb/s (10 Mb/s not supported; 100 Mb/s supported but not optimal)

**Auto MDI/MDI-X Support:** yes

**NIC Status LEDs:** one link and one activity

### **Power Source:**

**Power-over-Ethernet (PoE):** class 2 (low power, ≤6.49 watts) per IEEE® 802.3af

**Configuration:** requires Studio Technologies' STcontroller software application

### **Connectors:**

**Ethernet:** 1, RJ45

**USB:** type A receptacle (used only for updating application and FPGA firmware)

**Software Updating:** USB flash drive used for updating application and FPGA firmware; Dante Controller or Dante Firmware Update Manager applications can be used for updating Dante interface firmware

**Front Panel LEDs:** 2, dual-color

**Function:** provides indication of status of Dante connectivity

### **Environmental:**

**Operating Temperature:** 0 to 50 degrees C (32 to 122 degrees F)

**Storage Temperature:** –40 to 70 degrees C (–40 to 158 degrees F)

**Humidity:** 5 to 95%, non-condensing

**Altitude:** not characterized

### **Dimensions – Overall:**

8.7 inches wide (22.1 cm)

1.72 inches high (4.4 cm)

8.3 inches deep (21.1 cm)

**Deployment:** intended for tabletop applications. Four optional mounting kits are also available:

RMBK-10 allows one unit to be mounted in a panel cutout or on a flat surface

RMBK-11 allows one unit to be mounted in the left- or right-side of one space (1U) of a standard 19-inch rack

RMBK-12 allows two units to be mounted in one space (1U) of a standard 19-inch rack

RMBK-13 allows one unit to be mounted in the center of one space (1U) of a standard 19-inch rack

**Weight:** 1.3 pounds (0.59 kg); rack-mount installation kits add 0.2 pounds (0.09 kg)

Specifications and information contained in this User Guide subject to change without notice.

## **Appendix A–STcontroller Default Configuration Values**

System – Channels per Group: 8,8

System – Group A Function: Party-Line w/ Auto Mix

System – Group B Function: Party-Line w/ Auto Mix

System – Group C Function: Party-Line w/ Auto Mix

System – Group D Function: Party-Line w/ Auto Mix

## Appendix B—Graphical Description of the Installation Kit for Panel Cutout or Surface-Mounting Use (Order Code: *RMBK-10*)

This installation kit is used for mounting one Model 5421 unit into a panel cutout or flat surface.

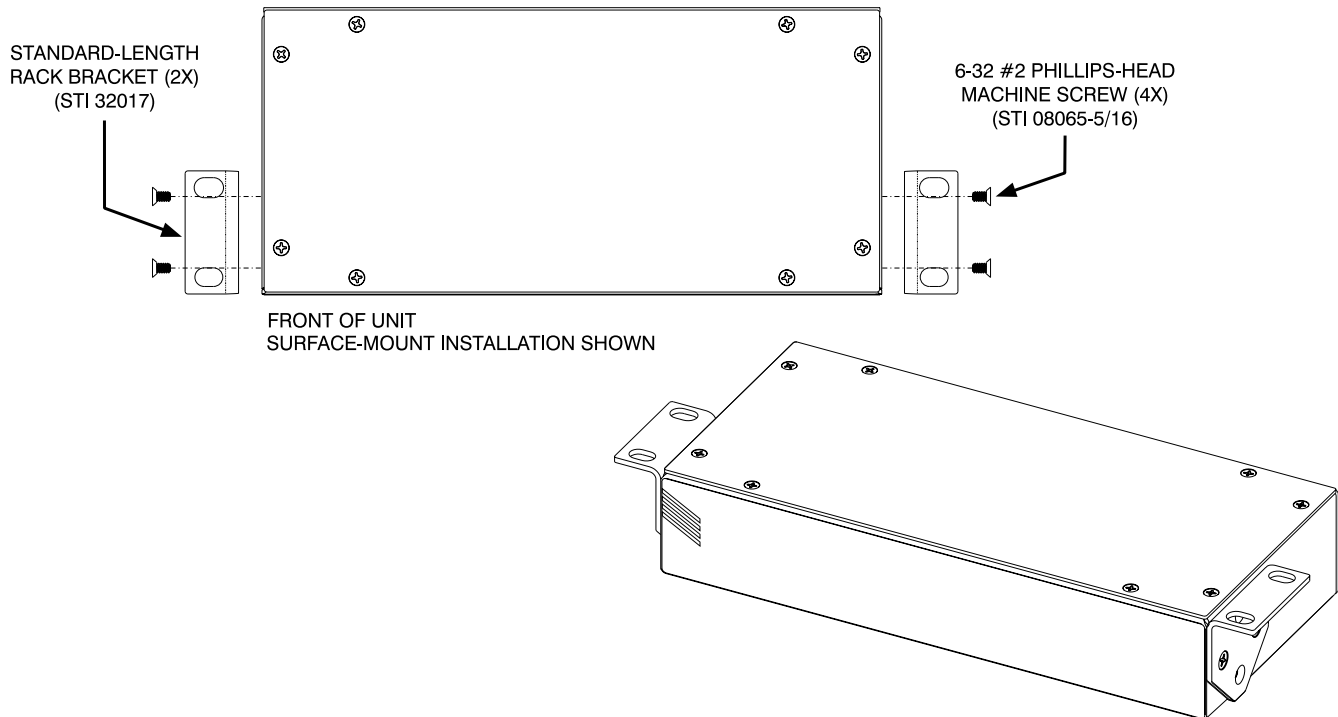
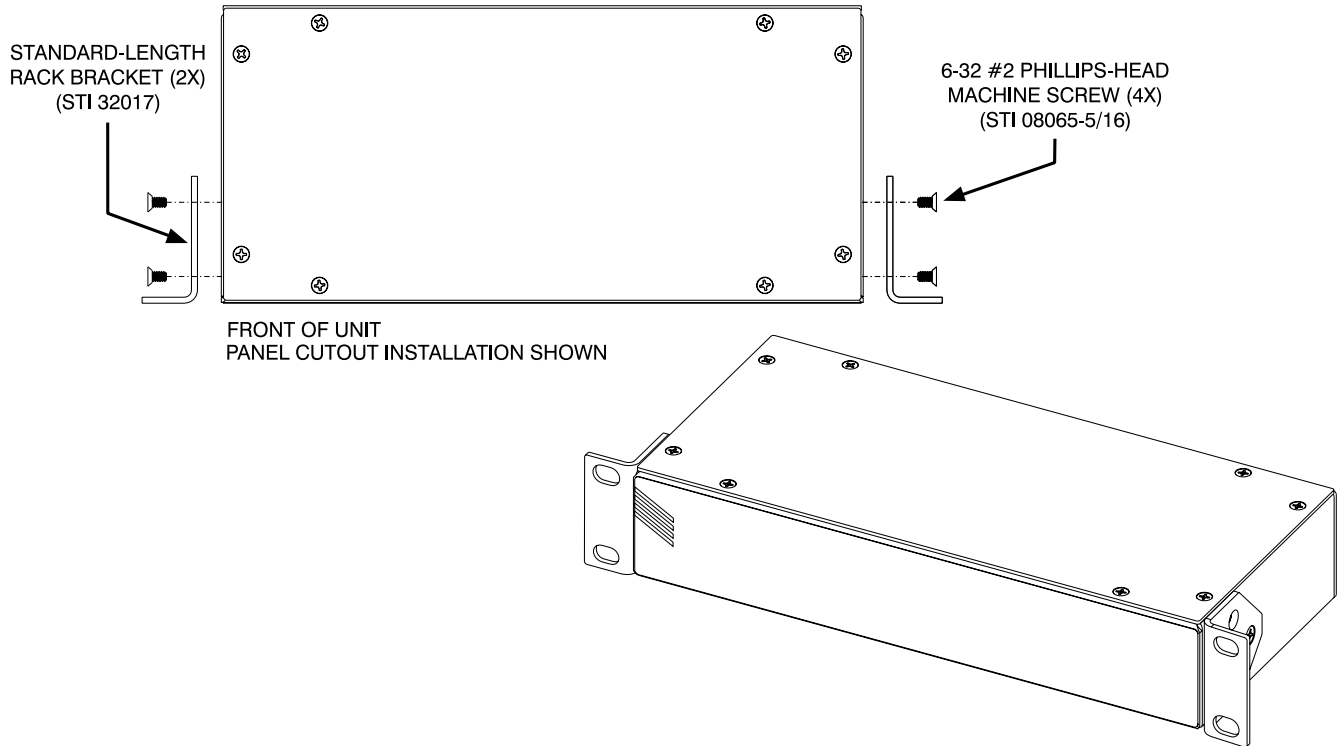

## Appendix C—Graphical Description of Left- or Right-Side Rack-Mount Installation Kit for One “1/2-Rack” Unit (Order Code: *RMBK-11*)

This installation kit is used for mounting one Model 5421 unit into one space (1U) of a 19-inch equipment rack. Unit will be located on the left- or right-side of the 1U opening.

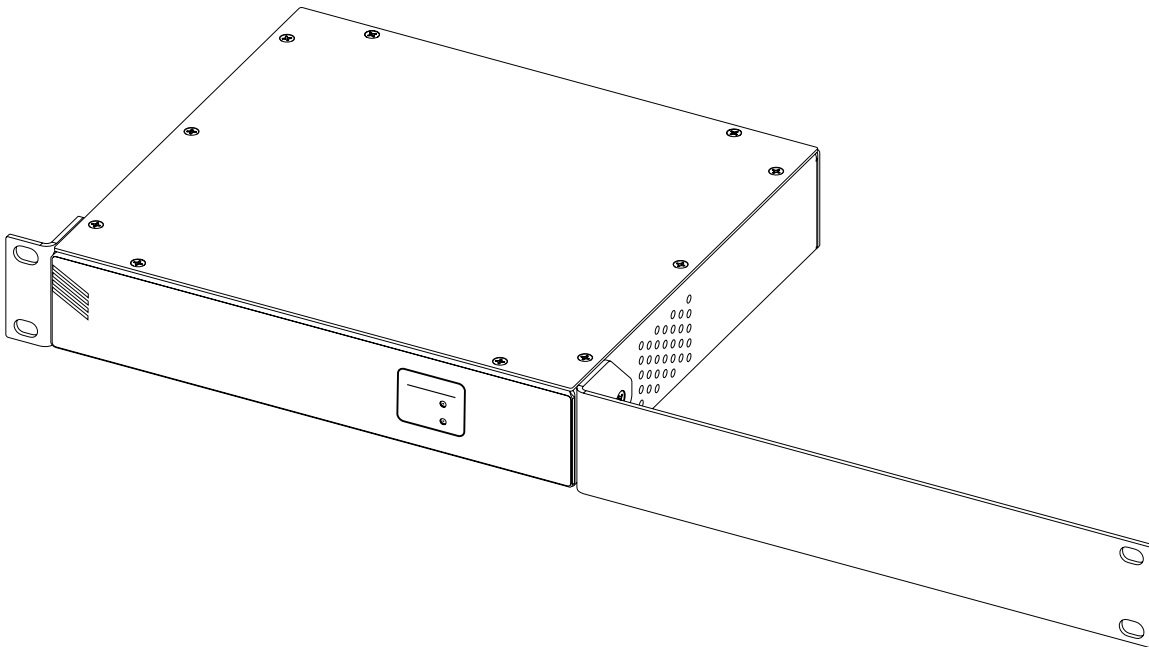
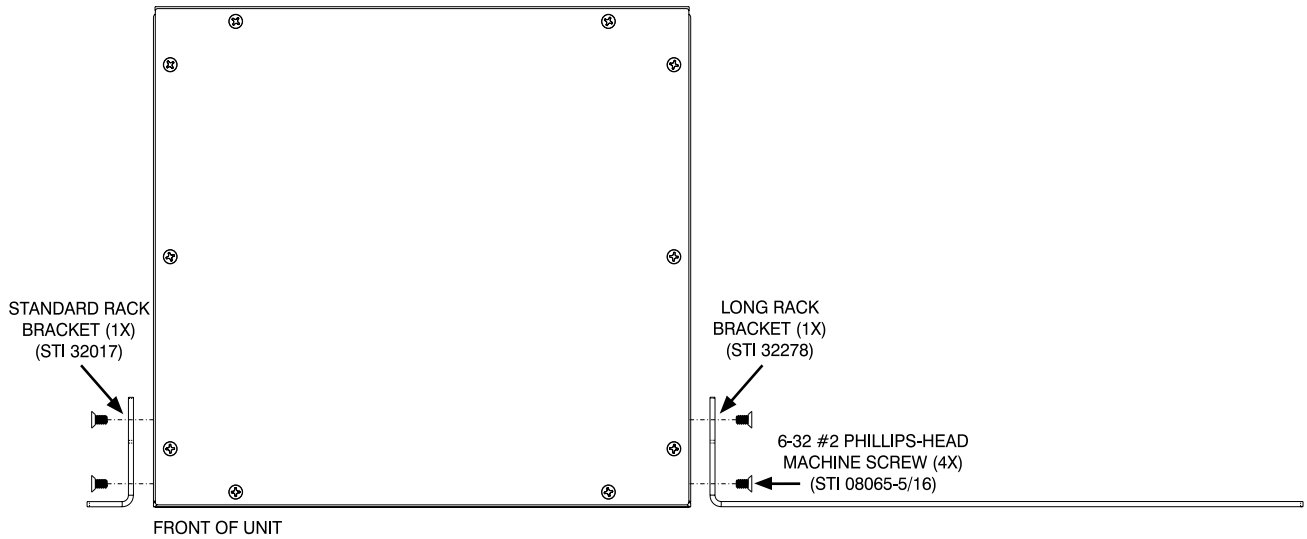

## Appendix D—Graphical Description of Rack-Mount Installation Kit for Two Model 5421 Units (Order Code: *RMBK-12*)

This installation kit can be used to mount two Model 5421 units or one Model 5421 unit and another product that is compatible with the RMBK-12 (such as the Studio Technologies' Model 544D Interface) into one space (1U) of a 19-inch equipment rack.

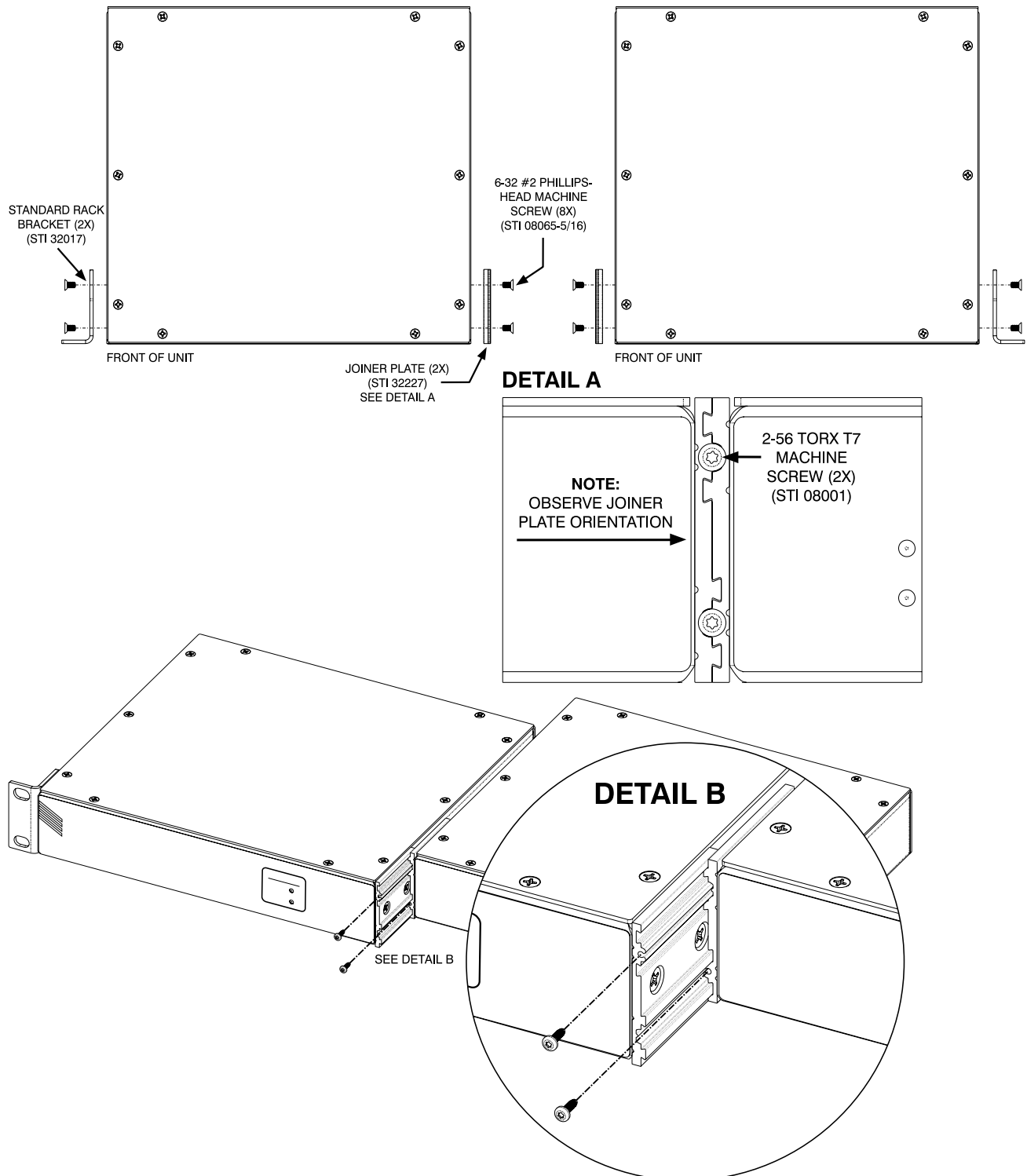

## Appendix E—Graphical Description of Center Rack-Mount Installation Kit for One “1/2-Rack” Unit (Order Code: *RMBK-13*)

This installation kit is used for mounting one Model 5421 unit into one space (1U) of a 19-inch equipment rack. Unit will be located in the center of the 1U opening.

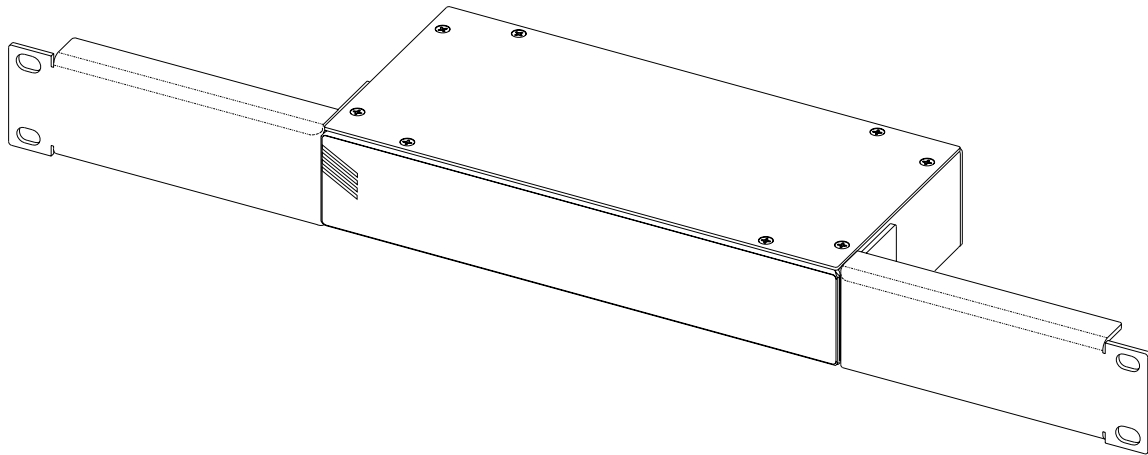
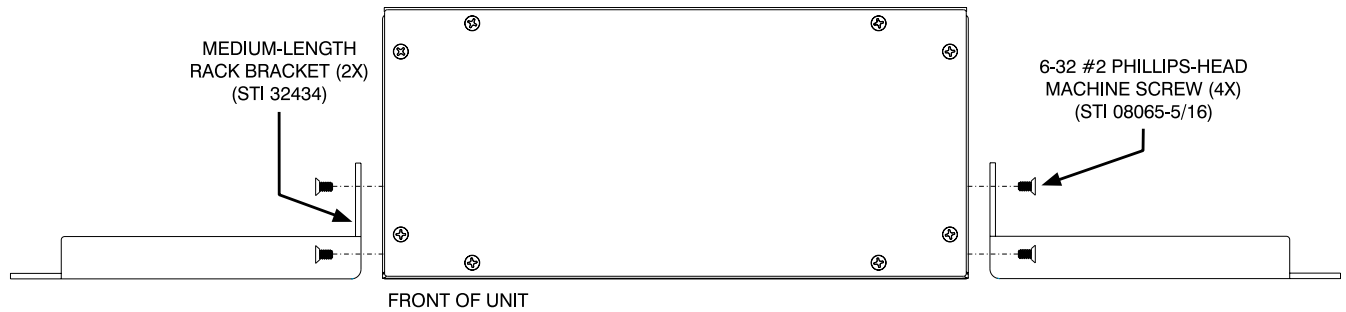

## Appendix F—Example of Model 5421 Routes (Subscriptions) made using Dante Controller

The screenshot displays the Dante Controller Network View interface. At the top, the title bar reads "Dante Controller - Network View" and the status bar shows "Grand Master Clock: ST-M5421-d00062". The main window is divided into several sections:

- Routing:** The central table shows routing connections. The columns represent source devices and the rows represent destination devices.
 

| Source                 | Destination | Routing |
|------------------------|-------------|---------|
| ST-M372A-81d7d0 (Talk) | A01-Group A | ✓       |
| ST-M372A-81d7d7 (Talk) | A02-Group A | ✓       |
| ST-M372A-81d7e0 (Talk) | A03-Group A | ✓       |
| ST-M372A-81d7e3 (Talk) | A04-Group A | ✓       |
| ST-M5421-d00062 (Talk) | A05-Group A | ✓       |
| ST-M5421-d00062 (Talk) | A06-Group A | ✓       |
| ST-M5421-d00062 (Talk) | A07-Group A | ✓       |
| ST-M5421-d00062 (Talk) | A08-Group A | ✓       |
| ST-M5421-d00062 (Talk) | B01-Group B | ✓       |
| ST-M5421-d00062 (Talk) | B02-Group B | ✓       |
| ST-M5421-d00062 (Talk) | B03-Group B | ✓       |
| ST-M5421-d00062 (Talk) | B04-Group B | ✓       |
| ST-M5421-d00062 (Talk) | B05-Group B | ✓       |
| ST-M5421-d00062 (Talk) | B06-Group B | ✓       |
| ST-M5421-d00062 (Talk) | B07-Group B | ✓       |
| ST-M5421-d00062 (Talk) | B08-Group B | ✓       |
- Dante Receivers:** Lists receiver devices with their channels and status.
  - ST-M372A-81d7d0: Headphone Ch1, Headphone Ch2 (Status: ✓)
  - ST-M372A-81d7d7: Headphone Ch1, Headphone Ch2 (Status: ✓)
  - ST-M372A-81d7e0: Headphone Ch1, Headphone Ch2 (Status: ✓)
  - ST-M372A-81d7e3: Headphone Ch1, Headphone Ch2 (Status: ✓)
  - ST-M5421-d00062: A01-Group A through A07-Group A (Status: ✓)
- Dante Transmitters:** Shows a list of transmitters for the selected route.
  - ST-M5421-d00446: A01-Group A through A08-Group A, B01-Group B through B08-Group B (Status: 1)
- Receivers (1):** Shows a list of receivers for the selected route.
  - ST-M5421-d00446: A01-Group A through A08-Group A, B01-Group B through B08-Group B (Status: 1)

