

Encore3

Event Master



User guide

Product revision

Software Revision: Event Master Toolset 10.0

Barco NV
Beneluxpark 21, 8500 Kortrijk, Belgium
www.barco.com

Manufacturer: Barco Inc., Image Processing
11080 White Rock Rd. Suite 100, Rancho Cordova, CA 95670, USA

Copyright ©

All rights reserved. No part of this document may be copied, reproduced or translated. It shall not otherwise be recorded, transmitted or stored in a retrieval system without the prior written consent of Barco.

Trademarks

Brand and product names mentioned in this manual may be trademarks, registered trademarks or copyrights of their respective holders. All brand and product names mentioned in this manual serve as comments or examples and are not to be understood as advertising for the products or their manufacturers.

Patent protection

Please refer to <https://www.barco.com/about-barco/legal/patents>.

Changes

Barco provides this manual 'as is' without warranty of any kind, either expressed or implied, including but not limited to the implied warranties or merchantability and fitness for a particular purpose. Barco may make improvements and/or changes to the product(s) and/or the program(s) described in this publication at any time without notice.

This publication could contain technical inaccuracies or typographical errors. Changes are periodically made to the information in this publication; these changes are incorporated in new editions of this publication.

The latest edition of Barco manuals can be downloaded from the Barco website <https://www.barco.com>.

Product Security Incident Response

As a global technology leader, Barco is committed to deliver secure solutions and services to our customers, while protecting Barco's intellectual property. When product security concerns are received, the product security incident response process will be triggered immediately. To address specific security concerns or to report security issues with Barco products, please inform us via contact details mentioned on <https://www.barco.com/psirt>. To protect our customers, Barco does not publicly disclose or confirm security vulnerabilities until Barco has conducted an analysis of the product and issued fixes and/or mitigations.

Guarantee and Compensation

Barco provides a guarantee relating to perfect manufacturing as part of the legally stipulated terms of guarantee. On receipt, the purchaser must immediately inspect all delivered goods for damage incurred during transport, as well as for material and manufacturing faults Barco must be informed immediately in writing of any complaints.

The period of guarantee begins on the date of transfer of risks, in the case of special systems and software on the date of commissioning, at latest 30 days after the transfer of risks. In the event of justified notice of complaint, Barco can repair the fault or provide a replacement at its own discretion within an appropriate period. If this measure proves to be impossible or unsuccessful, the purchaser can demand a reduction in the purchase price or cancellation of the contract. All other claims, in particular those relating to compensation for direct or indirect damage, and also damage attributed to the operation of software as well as to other services provided by Barco, being a component of the system or independent service, will be deemed invalid provided the damage is not proven to be attributed to the absence of properties guaranteed in writing or due to the intent or gross negligence or part of Barco.

If the purchaser or a third party carries out modifications or repairs on goods delivered by Barco, or if the goods are handled incorrectly, in particular if the systems are operated incorrectly or if, after the transfer of risks, the goods are subject to influences not agreed upon in the contract, all guarantee claims of the purchaser will be rendered invalid. Not included in the guarantee coverage are system failures which are attributed to programs or special electronic circuitry provided by the purchaser, e.g. interfaces. Normal wear as well as normal maintenance are not subject to the guarantee provided by Barco either.

The environmental conditions as well as the servicing and maintenance regulations specified in this manual must be complied with by the customer.

Disclaimer on screenshot images used in this manual

The screenshot images used in this manual are example illustrations and should be treated as such. While the name of the product displayed in the images may be different from the product model currently used, the menu lay-out and functionality is identical.

Software License Agreement

Carefully read the following terms and conditions before using this software. Any use of this software indicates the acceptance of this license agreement and warranty.

Terms and Conditions:

1. No redistribution of the software is allowed.
2. Reverse-Engineering. This software product may not be reverse engineered, decompiled, disassembled or altered.

Disclaimer of Warranty:

This software and the accompanying files are sold "as is" and without warranties as to performance or merchantability or any other warranties whether expressed or implied. In no event shall Barco be liable for damage of any kind, loss of data, loss of profits, business interruption or other pecuniary loss arising directly or indirectly. Any liability of the seller will be exclusively limited to replacement of the product or refund of purchase price.

Table of contents

1	Safety	11
1.1	General considerations	12
1.2	Important safety instructions	12
2	Introduction	15
2.1	About Event Master devices	16
2.2	Conventions	16
2.3	Encore3	16
2.3.1	Introduction	16
2.3.2	Dante audio and LTC	17
2.3.3	Air flow	18
2.3.4	Card slot designations	18
2.4	Event Master cards	19
2.4.1	Introduction	19
2.4.2	H2.0 quad input card	19
2.4.3	DisplayPort1.2 quad input card	19
2.4.4	Tri-combo input card	20
2.4.5	H2.0 quad output card	21
2.4.6	DisplayPort1.2 quad output card	21
2.4.7	Tri-combo output card	22
2.4.8	100G high speed expansion quad link card	23
2.5	Event Master controllers	23
2.5.1	Introduction	24
2.5.2	EC-30	24
2.5.3	EC-50	25
2.6	Resources	25
2.6.1	Definitions	25
2.6.2	Overview	26
2.6.3	Single screen resource allocation	27
2.6.4	Wide screen resource allocation	27
2.6.5	Linked resources	28
3	Process overview	29
3.1	General process	30
3.2	ShowFile process	30
3.3	Installation process	31

4	Installation	33
4.1	Installation requirements	34
4.2	Removing an Event Master card	35
4.3	Installing an Event Master card	36
4.4	Rack mounting	37
4.5	Linking two Encore3s	39
4.6	Control connection	40
4.7	Genlock connection	41
4.8	Powering the Encore3	42
4.9	Waking the Encore3	43
4.10	Connecting an EC-30	43
4.11	Connecting an EC-50	44
5	Encore3 front panel	47
5.1	Introduction	48
5.2	System	48
5.2.1	Unit ID, IP address	49
5.2.2	Front panel	50
5.2.3	Firmware upgrade	51
5.2.4	Diagnostics	52
5.2.4.1	About diagnostics	52
5.2.4.2	Hardware diagnostics	53
5.2.4.3	Temperature diagnostics	54
5.2.4.4	Log files	55
5.2.5	Security	55
5.2.6	Save	56
5.3	Test pattern	57
5.4	ShowFile management	58
5.4.1	Backup	58
5.4.2	Restore	59
5.4.3	Import stills	61
5.4.4	Export stills	62
5.5	Widget panel	63
5.6	Reset	64
5.6.1	Soft reset	64
5.6.2	Factory reset and keep	64
5.6.3	Factory reset	65
5.6.4	Shut down	65
6	Encore3 web page	67
6.1	Introduction	68
6.2	Accessing the web page	68
6.3	Widget panel	69
6.4	Tools	70
6.4.1	Manage software	70
6.4.2	Backup	71
6.4.3	Restore	72
6.4.4	Diagnostics/system logs	74
6.4.5	Security	75
6.5	Help	76
6.5.1	Use JSON	76
6.5.2	Contact us	78
6.6	About	78

7	Event Master Toolset	81
7.1	Introduction	82
7.2	Setup requirement	82
7.3	Event Master Toolset installation	83
7.4	About the user interface	84
7.5	The simulator	86
7.6	Multi-operator mode	88
7.7	Multi-systems	89
7.8	Configuration	90
7.8.1	System creation	90
7.8.2	Linked units	92
7.8.3	Disconnect a system	93
7.8.4	Managing unit(s).....	93
7.8.4.1	System settings	93
7.8.4.2	Genlock	94
7.8.4.3	Unit information	95
7.8.4.4	Reset unit	96
7.8.4.5	Temperature	97
7.8.4.6	Setup	97
7.8.4.7	TCI mode	99
7.8.4.8	Time setting	99
7.8.5	Managing destinations	100
7.8.5.1	Deleting destinations	100
7.8.5.2	Creating destinations	101
7.8.5.3	Editing screen destinations	102
7.8.6	Managing inputs	103
7.8.6.1	Creating inputs	104
7.8.6.2	Deleting inputs	105
7.8.6.3	Editing inputs	105
7.8.7	MVR configuration	107
7.8.8	Custom files	109
7.8.9	System view	110
7.8.10	Link resources	111
7.9	MVR	112
7.9.1	Getting started	112
7.9.2	Editing an MVR layout	112
7.9.3	MVR presets	114
7.10	Programming	115
7.10.1	Manage layout(s)	115
7.10.1.1	Creating a layout	115
7.10.1.2	Removing a destination from a layout	116
7.10.2	Destination group	117
7.10.3	Layers	118
7.10.3.1	Mixing or splitting layers	118
7.10.3.2	Screen and output layers	119
7.10.4	Organizing lists	119
7.10.5	Adding stills	121
7.10.6	Capturing stills	121
7.10.7	Source thumbnail	122
7.10.8	Adding backup input	123
7.10.9	Multiple sources	123
7.10.10	Scene creation	124
7.10.10.1	Adding a layer	125
7.10.10.2	Adding a source	125

7.10.10.3	Mix background layer	126
7.10.10.4	Removing a layer	127
7.10.10.5	Positioning a layer	128
7.10.10.6	Layer Z-order	129
7.10.10.7	Editing a layer	130
7.10.10.8	Editing a source	131
7.10.10.9	Applying a move animation	131
7.10.11	User keys	133
7.10.12	Presets	134
7.10.12.1	Creating a preset	134
7.10.12.2	Recalling a preset	135
7.10.13	Transitioning a scene	136
7.10.14	Playing cues	137
7.11	External devices & cues	138
7.11.1	External devices	138
7.11.2	Creating commands	139
7.11.3	Creating a cue	140
7.11.4	Managing actions	141
7.11.5	Scheduling a cue	143
7.12	Tally	144
7.12.1	Configuring a tally	144
7.12.2	Tally assignment	145
7.13	Controller	146
7.13.1	Getting started	146
7.13.2	Assign mapping	147
7.13.3	Deleting mapping	148
7.13.4	Using the controller	149
7.14	ShowFile	149
7.14.1	Backup	149
7.14.2	Restore	150
7.14.3	ShowFile editor	150
7.15	Network	151
7.15.1	Managing network settings	151
7.16	Widget	152
7.16.1	Creating a widget	152
7.16.2	Editing a widget	153
7.16.3	Using a widget	155
7.17	Settings	156
7.17.1	Unit web page	156
7.17.2	Event Master Toolset options	156
7.17.3	Controller settings	157

8 Using Event Master controllers 159

8.1	Color	160
8.2	Destination buttons	160
8.3	Layer buttons	161
8.4	Assign buttons	162
8.5	Transition buttons	164
8.6	User assigned buttons	164
8.7	T-bar	165
8.8	Built-in touch screen	165

9 Service 167

9.1	Replacing the power supply	168
-----	----------------------------------	-----

10 Preventative maintenance	169
10.1 One-year maintenance actions	170
10.2 Four-year maintenance actions	170
11 Troubleshooting	171
11.1 Troubleshooting abnormal Encore3 behavior	172
A Specifications	175
A.1 Event Master processor specifications	176
A.2 Input cards specifications	177
A.3 Output cards specifications	179
A.4 Link cards specifications	180
A.5 Event Master controllers specifications	180
B Regulatory	183
B.1 Product and contact references	184
B.2 Product compliance EU	184
B.3 Product compliance UK	185
B.4 Product compliance US	185
B.5 Product compliance Turkey	185
B.6 Product compliance China	185
B.7 Product compliance Taiwan	187
B.8 Product compliance Korea	188
B.9 Trademark notice	188
B.10 Product privacy statement	188
C License info	191
C.1 Open source software	192
Glossary	193
List of tools	197
Index	199

Safety

1

1.1	General considerations	12
1.2	Important safety instructions	12

Clarification of the term “Encore3” used in this document

References in this document to the term “Encore3” means that the content is applicable for following Barco products:

- NGS-4U-V3

Model certification name

- NGS-4U-V3



Barco provides a guarantee relating to perfect manufacturing as part of the legally stipulated terms of guarantee. Observing the specification mentioned in this chapter is critical for optimal performance. Neglecting this can result in loss of warranty.

1.1 General considerations

General safety instructions

- Before operating this equipment please read this manual thoroughly and retain it for future reference.
- All warnings on the unit and in its documentation manuals must be adhered to.
- Installation and preliminary adjustments must be performed by qualified Barco personnel or by authorized Barco service dealers.
- This product contains no user serviceable parts. Attempts to modify/replace mechanics or electronics inside the housing or compartments will violate any warranties and may be hazardous.
- All instructions for operating and use of this equipment must be followed precisely.
- All local installation codes must be adhered to.

Notice on safety

This equipment is built in accordance with the requirements of the applicable international safety standards. These safety standards impose important requirements on the use of safety critical components, materials and insulation, in order to protect the user or operator against risk of electric shock and energy hazard and having access to live parts. Safety standards also impose limits to the internal and external temperature rises, radiation levels, mechanical stability and strength, enclosure construction and protection against the risk of fire. Simulated single fault condition testing ensures the safety of the equipment to the user even when the equipment's normal operation fails.

1.2 Important safety instructions

To prevent risk, personal injury and Encore3 damage

Please read this chapter carefully. It contains important information to prevent personal injury while installing the Encore3. Furthermore, it includes several cautions to prevent damage to the Encore3. Ensure that you understand and follow all safety guidelines, safety instructions and warnings mentioned in this chapter before installing the Encore3. After this chapter, additional “warnings” and “cautions” are given depending on the installation procedure. Read and follow these “warnings” and “cautions” as well.

- Read these instructions.
- Keep these instructions.
- Heed all warnings.
- Follow all instructions.
- Only trained technicians may install the Encore3.
- Installation of the Encore3 must be done in a dust free area.
- Only use attachments/accessories specified by the manufacturer.
- CAUTION: Troubleshooting must be performed by a trained technician. To reduce the risk of electrical shock, do not attempt to service this equipment unless you are qualified to do so.
- Refer all servicing to qualified service personnel. Servicing is required when the system has been damaged in any way, such as liquid has been spilled or objects have fallen into the system, or the system has been exposed to rain or moisture, does not operate normally, or has been dropped.
- FRAGILE: The Encore3 is fragile. Handle the Encore3 with care at all times.
- To prevent injury, take note: by law, minimum 2 persons are required to carry the Encore3.
- Do not remove covers or panels during normal operation. Removal of the top cover will expose dangerous voltages. To avoid personal injury, do not remove the top cover. Do not operate the unit without the cover installed.
- During maintenance operations, always switch off the Encore3 and unplug power cords before removing one of the covers, unless otherwise stated.
- Always wear a wrist band which is connected to the ground while handling the ESD sensitive parts.
- Wear insulating gloves during the execution of the installation and maintenance actions to avoid short-circuit.
- Be careful never to drop anything into the Encore3 assembly during the procedure. The fall of a tool or a spare part in the Encore3 could have catastrophic consequences when you will restart the system.
- Be careful to always follow strict procedures during maintenance operations (spare parts replacement).

- This product is intended to operate from a power source that will not apply more than 230 volts rms between the supply conductors or between both supply conductor and ground. A protective ground connection by way of grounding conductor in the power cord is essential for safe operation.
- This product is grounded through the grounding conductor of the power cord. To avoid electrical shock, plug the power cord into a properly wired receptacle before connecting to the product input or output terminals. A protective-ground connection by way of the grounding conductor in the power cord is essential for safe operation.
- Use only the power cord and connector specified for your product. Use only a power cord that is in good condition. Refer cord and connector changes to qualified service personnel.
- To avoid fire hazard, use only the fuse having identical type, voltage rating, and current rating characteristics. Refer fuse replacement to qualified service personnel.
- Replace spare parts only with the same or equivalent type recommended by the manufacturer.
- Save the original shipping carton and packing material. They will come in handy if you ever have to ship your equipment. For maximum protection, repack your set as it was originally packed at the factory.
- Rated maximum ambient operating temperature, $t_a = 40^\circ\text{C}$ (104°F).
- To avoid explosion, do not operate this product in an explosive atmosphere.

On servicing

- Do not attempt to service this product yourself, as opening or removing covers may expose you to dangerous voltage potentials and risk of electric shock.
- Refer all servicing to qualified service personnel.
- Attempts to alter the factory-set internal controls or to change other control settings not specially discussed in this manual can lead to permanent damage to the unit and cancellation of the warranty.
- Replacement parts: When replacement parts are required, be sure the service technician has used original Barco replacement parts or authorized replacement parts which have the same characteristics as the Barco original part. Unauthorized substitutions may result in degraded performance and reliability, fire, electric shock or other hazards. Unauthorized substitutions may void warranty.
- Safety check: Upon completion of any service or repairs to this unit, ask the service technician to perform safety checks to determine that the product is in proper operating condition.

Malfunction unit

Remove all power from the product and refer servicing to qualified service technicians under the following conditions:

- When the power cord or plug is damaged or frayed.
- If liquid has been spilled into the equipment.
- If the product has been exposed to rain or water.
- If the product does not operate normally when the operating instructions are followed. Adjust only those controls that are covered by the operating instructions since improper adjustment of the other controls may result in damage and will often require extensive work by a qualified technician to restore the product to normal operation.
- If the product has been dropped or the cabinet has been damaged.
- If the product exhibits a distinct change in performance, indicating a need for service.

Introduction

2

2.1	About Event Master devices	16
2.2	Conventions	16
2.3	Encore3	16
2.4	Event Master cards	19
2.5	Event Master controllers	23
2.6	Resources	25

About this document

This user guide explains how to install and make use of the Event Master system with an Encore3 at its core.

About introduction

Details about the Event Master processor, the Encore3, and its controllers, the EC-30 and the EC-50, will be explored in the following chapters.

2.1 About Event Master devices

Overview

An Event Master setup typically consists of a video processing component optionally controlled by an Event Master controller.

The full Event Master Encore3 hardware offering consists of the following devices:

Video processing	Event Master controller (optional)
Encore3	EC-30
	EC-50

2.2 Conventions

Encore3 orientation

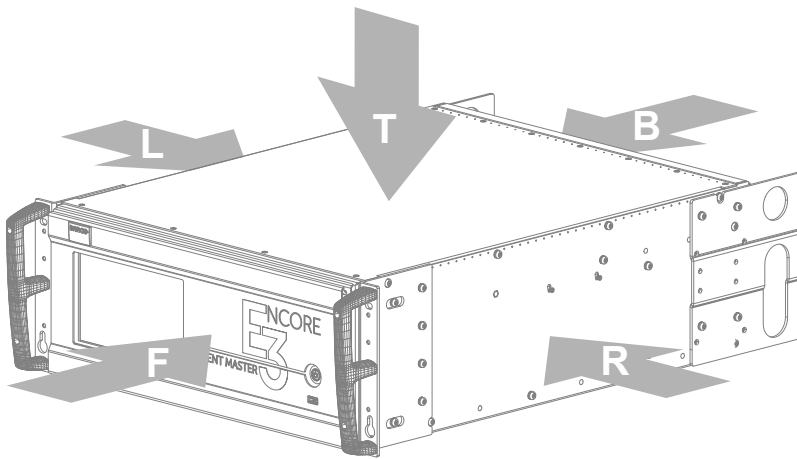

Image 2-1

T Top side
L Left side
F Front side

R Right side
B Back side

2.3 Encore3

About this chapter

A full overview of the components and design of the Encore3 will be explored in the following chapters.

2.3.1 Introduction

About Encore3

The Encore3 is a modular video processor allowing for multiple configurations. These configurations can be scaled or consist out of different combinations depending on the need, size and nature of the event or application.



Image 2–2

Encore3 components

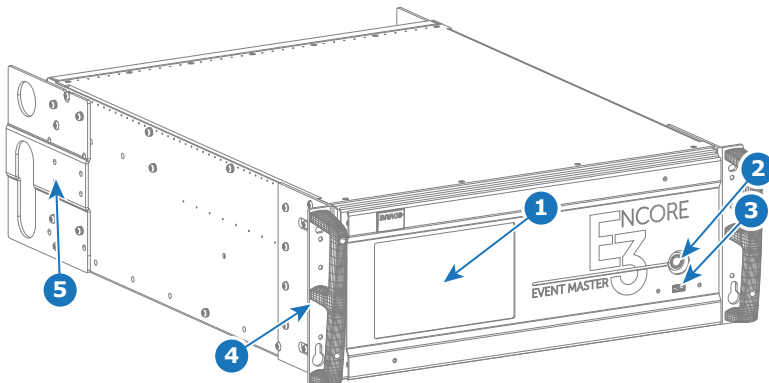

Image 2–3

- | | |
|-------------------------|------------------------------------|
| 1 Touch panel | 4 Rack handles |
| 2 Power button | 5 Rear connector protectors |
| 3 Front USB port | |

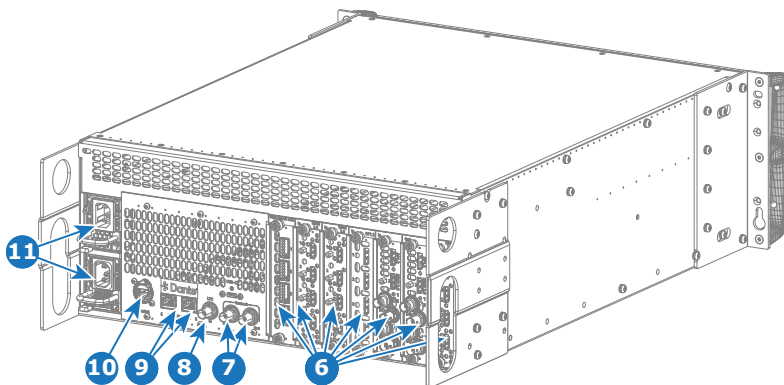

Image 2–4

- | | |
|----------------------------------|---------------------------------|
| 6 Event Master card slots | 9 Dante audio connectors |
| 7 Genlock connectors | 10 Control connector |
| 8 LTC connector | 11 Power supplies |

2.3.2 Dante audio and LTC

About Dante audio and LTC

Dante audio and LTC functionality are currently not available.

2.3.3 Air flow

About air flow

The Encore3 is air cooled. Cold air gets sucked in at the air inlets on the front and used to cool the internal electronics. This heated up air then gets blown out the back and away from the Encore3.

For more information on required clearance, see [“Installation requirements”](#), page 34.

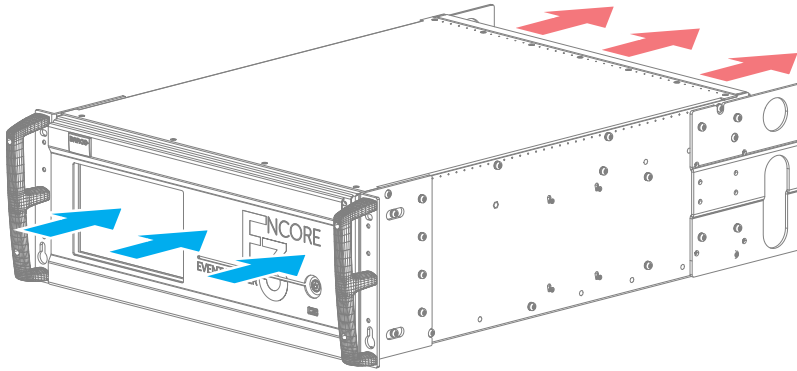

Image 2-5

2.3.4 Card slot designations

About slot designations

Each slot is configured to take certain type of cards. Some of these slots can support two different types of cards. Each slot is colored according to the type of card it can support:

- **Blue:** input slots.
- **Green:** output slots.
- **Yellow:** link slots.

It is not possible to use a type of card in a card slot which does not support that type.

Encore3 slot layout

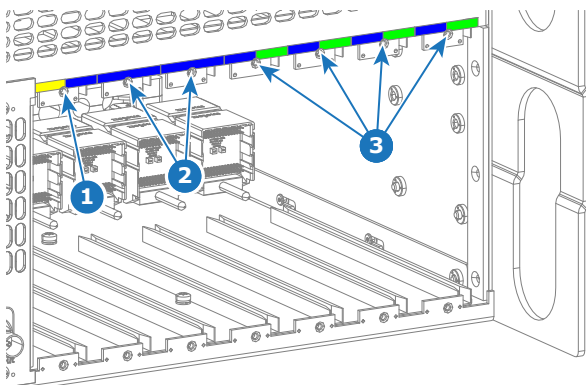

Image 2-6

- 1 Link or input slot
- 2 Input only slot
- 3 Input or output slot

2.4 Event Master cards

About this chapter

A full overview of all Event Master cards supported by the Encore3 will be explored in the following chapters.

2.4.1 Introduction

About Event Master cards

Event Master cards can be one of three types. The color of the card defines the type of card it is:

- **Blue:** input cards.
- **Green:** output cards.
- **Yellow:** link cards.

It is not possible to use an input card as an output card or vice versa, even if they look physically identical.

2.4.2 H2.0 quad input card



HDMI

High-Definition Multimedia Interface (HDMI) is a compact audio / video interface for transferring uncompressed video data and compressed / uncompressed digital audio data from an HDMI-compliant device, the source device, to a compatible computer monitor, video projector, digital television, or digital audio device. HDMI is a digital replacement for existing analog video standards.

Overview

The quad HDMI™ 2.0 (gen 2) input card allows up to four independent HDMI signals to be connected. When a valid HDMI signal is connected, then the nearest indicator light will turn green.

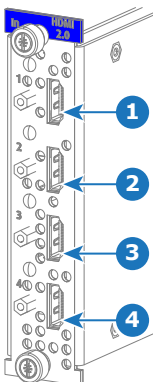

Image 2-7

- 1 HDMI2.0 connector with indicator LED
- 2 HDMI2.0 connector with indicator LED
- 3 HDMI2.0 connector with indicator LED
- 4 HDMI2.0 connector with indicator LED

2.4.3 DisplayPort1.2 quad input card



DisplayPort

Digital display interface developed by the Video Electronics Standards Association (VESA). This interface is primarily used to connect a video source to a display device such as a computer monitor, though it can also be used to transmit audio, USB, and other forms of data.

Overview

The quad DisplayPort 1.2 (gen 2) input card allows up to four independent DP signals to be connected. When a valid DP signal is connected, then the nearest indicator light will turn green.

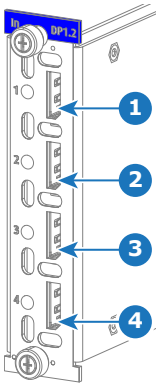

Image 2–8

- 1 DisplayPort1.2 connector with indicator LED
- 2 DisplayPort1.2 connector with indicator LED
- 3 DisplayPort1.2 connector with indicator LED
- 4 DisplayPort1.2 connector with indicator LED

2.4.4 Tri-combo input card



DisplayPort

Digital display interface developed by the Video Electronics Standards Association (VESA). This interface is primarily used to connect a video source to a display device such as a computer monitor, though it can also be used to transmit audio, USB, and other forms of data.



HDMI

High-Definition Multimedia Interface (HDMI) is a compact audio / video interface for transferring uncompressed video data and compressed / uncompressed digital audio data from an HDMI-compliant device, the source device, to a compatible computer monitor, video projector, digital television, or digital audio device. HDMI is a digital replacement for existing analog video standards.



SDI

Serial Digital Interface (SDI) is a serial link standardized by the Society of Motion Picture and Television Engineers (SMPTE). SDI transmits uncompressed digital video over a 75-ohm coaxial cable, typically within studios, and is seen as the most professional video infrastructure equipment.



BNC

Bayonet Neill-Concelman (BNC) is a method of connecting coaxial cables to a BNC connector using a twist lock design. This twist lock ensures that the cable and the connector are in optimal contact and are hard to dislodge by accident. It enables the transmission of serial digital video, timing signals or audio signals.

Overview

The Tri-combo (gen 2) input card allows up to four independent signals to be active. Which four connectors accept a signal can be configured in the Event Master Toolset. For more information, see [“TCI mode”, page 99](#). When a valid signal is connected, then the nearest indicator light will turn green.



By default the top four connectors are active.

A mix of different signals can be used to make up the four possible connections:

- **DP 1.2** connection, using the DisplayPort connector.
- **HDMI 2.0** connection, using the HDMI connector.
- **SD SDI** connection, using any of the BNC connectors.
- **HD SDI** connection, using any of the BNC connectors.
- **3G SDI** connection, using any of the BNC connectors.
- **6G SDI** connection, using any of the BNC connectors.

- **12G SDI (single link)** connection, using any of the BNC connectors.
- **12G SDI (quad link)** connection, using all four BNC connectors.

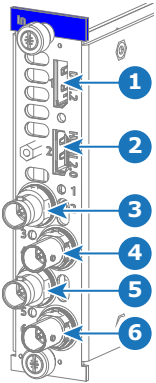

Image 2-9

- | | | | |
|----------|---------------------------------------------|----------|---------------------------------------|
| 1 | DisplayPort1.2 connector with indicator LED | 4 | SDI2 BNC connector with indicator LED |
| 2 | HDMI2.0 connector with indicator LED | 5 | SDI3 BNC connector with indicator LED |
| 3 | SDI1 BNC connector with indicator LED | 6 | SDI4 BNC connector with indicator LED |

2.4.5 H2.0 quad output card



HDMI

High-Definition Multimedia Interface (HDMI) is a compact audio / video interface for transferring uncompressed video data and compressed / uncompressed digital audio data from an HDMI-compliant device, the source device, to a compatible computer monitor, video projector, digital television, or digital audio device. HDMI is a digital replacement for existing analog video standards.

Overview

The quad HDMI™ 2.0 (gen 2) output card can process up to four independent HDMI signals. When a valid HDMI signal is being transmitted, then the nearest indicator light will turn green.

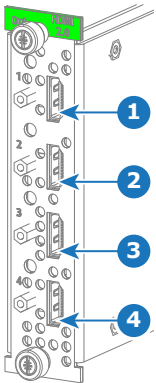

Image 2-10

- | | |
|----------|--------------------------------------|
| 1 | HDMI2.0 connector with indicator LED |
| 2 | HDMI2.0 connector with indicator LED |
| 3 | HDMI2.0 connector with indicator LED |
| 4 | HDMI2.0 connector with indicator LED |

2.4.6 DisplayPort1.2 quad output card



DisplayPort

Digital display interface developed by the Video Electronics Standards Association (VESA). This interface is primarily used to connect a video source to a display device such as a computer monitor, though it can also be used to transmit audio, USB, and other forms of data.

Overview

The quad DisplayPort 1.2 (gen 2) output card can process up to four independent DP signals. When a valid DP signal is being transmitted, then the nearest indicator light will turn green.

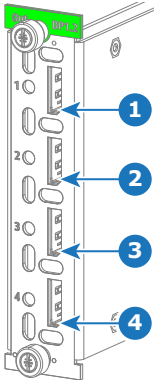

Image 2–11

- 1 DisplayPort1.2 connector with indicator LED
- 2 DisplayPort1.2 connector with indicator LED
- 3 DisplayPort1.2 connector with indicator LED
- 4 DisplayPort1.2 connector with indicator LED

2.4.7 Tri-combo output card



DisplayPort

Digital display interface developed by the Video Electronics Standards Association (VESA). This interface is primarily used to connect a video source to a display device such as a computer monitor, though it can also be used to transmit audio, USB, and other forms of data.



HDMI

High-Definition Multimedia Interface (HDMI) is a compact audio / video interface for transferring uncompressed video data and compressed / uncompressed digital audio data from an HDMI-compliant device, the source device, to a compatible computer monitor, video projector, digital television, or digital audio device. HDMI is a digital replacement for existing analog video standards.



SDI

Serial Digital Interface (SDI) is a serial link standardized by the Society of Motion Picture and Television Engineers (SMPTE). SDI transmits uncompressed digital video over a 75-ohm coaxial cable, typically within studios, and is seen as the most professional video infrastructure equipment.



BNC

Bayonet Neill-Concelman (BNC) is a method of connecting coaxial cables to a BNC connector using a twist lock design. This twist lock ensures that the cable and the connector are in optimal contact and are hard to dislodge by accident. It enables the transmission of serial digital video, timing signals or audio signals.

Overview

The Tri-combo (gen 2) output card allows for the processing of up to four independent signals. When a valid signal is being transmitted, then the nearest indicator light will turn green.

A mix of different signals can be used to make up the four possible connections:

- **DP 1.2** signal, using the DisplayPort connector.
- **HDMI 2.0** signal, using the HDMI connector.
- **SD SDI** signal, using any of the BNC connectors.
- **HD SDI** signal, using any of the BNC connectors.
- **3G SDI** signal, using any of the BNC connectors.
- **6G SDI** signal, using any of the BNC connectors.

- **12G SDI (single link)** signal, using any of the BNC connectors.
- **12G SDI (quad link)** signal, using all four BNC connectors.

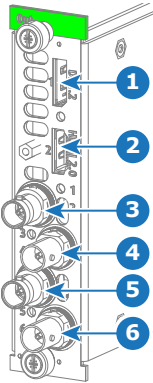

Image 2–12

- | | | | |
|----------|---------------------------------------------|----------|---------------------------------------|
| 1 | DisplayPort1.2 connector with indicator LED | 4 | SDI2 BNC connector with indicator LED |
| 2 | HDMI2.0 connector with indicator LED | 5 | SDI3 BNC connector with indicator LED |
| 3 | SDI1 BNC connector with indicator LED | 6 | SDI4 BNC connector with indicator LED |

2.4.8 100G high speed expansion quad link card



QSFP28

Quad Small Form-Factor Pluggable 28 is a copper or fiber optical connection that provides up to 100Gbps connectivity in parallel. It uses four hot-pluggable fiber or copper cables to ensure high speed transmission of data for high performance devices like the Encore3.

Overview

The link card allows for two Encore3s to share their inputs and outputs slots and their resources. These connections are made with QSFP28™ fiber or copper connections.

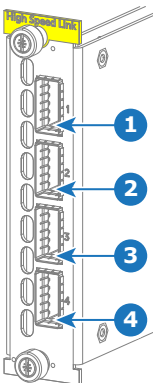

Image 2–13

- | | |
|----------|-----------------|
| 1 | QSFP28 module 1 |
| 2 | QSFP28 module 2 |
| 3 | QSFP28 module 3 |
| 4 | QSFP28 module 4 |

2.5 Event Master controllers

About this chapter

An overview of all Event Master controllers supported by Encore3 will be explored in the following chapters.

2.5.1 Introduction

About Event Master controllers

An Event Master controller helps with managing presets, controlling inputs, controlling destinations and transitions of scenes in real-time. How the controller buttons function, depends on the Event Master Toolset configuration of the Encore3. For more information on how to configure the Encore3 using Event Master Toolset, see [“Event Master Toolset”, page 81](#).

There are two types of Event Master controllers available:

- EC-30.
- EC-50, with a touch enabled display.

2.5.2 EC-30

Overview

The EC-30 controller is a compact controller providing programmable buttons and a T-bar.



Image 2–14

Button layout



For more information about the functionality of each button, see [“Using Event Master controllers”, page 159](#).



Image 2–15

- | | |
|---------------------------------------------------------------------------------------------------------|-----------------------------------------------------------------------------------------------------|
| <p>1 Screen destination buttons</p> <p>2 Layer buttons</p> <p>3 Custom buttons</p> | <p>4 T-bar</p> <p>5 Transition buttons</p> <p>6 Two rows of assign buttons</p> |
|---------------------------------------------------------------------------------------------------------|-----------------------------------------------------------------------------------------------------|

2.5.3 EC-50

Overview

The EC-50 controller is a controller providing programmable buttons, a T-bar and a built-in touch display.



Image 2-16

Button layout



For more information about the functionality of each button, see “Using Event Master controllers”, page 159.



Image 2-17

- | | |
|-----------------------------------------------------------------------------------------------------------------------------------|---------------------------------------------------------------------------------------------------------------------------------|
| <ul style="list-style-type: none"> 1 Screen destination buttons 2 Layer buttons 3 Custom buttons | <ul style="list-style-type: none"> 4 T-bar 5 Transition buttons 6 Three rows of assign buttons |
|-----------------------------------------------------------------------------------------------------------------------------------|---------------------------------------------------------------------------------------------------------------------------------|

2.6 Resources

About this chapter

How the Encore3 can use its image processing power will be explored in the following chapters.

2.6.1 Definitions



Single screen destination

A single screen destination is a display or a projector with a maximum 4K resolution. This single composition is then processed by the Event Master processor and displayed using one output.

**Mix layer**

Mix layers consist out of two customisable layers. An 'A' single layer and a 'B' single layer that are linked together. Each of these layers can have their own different layout. This makes it possible to seamlessly transition between desired layouts. For example, if layer 'A' is currently in program, a new layout can be prepared in preview using layer 'B'. Transitioning between the two layers causes layer 'B' to go to program and layer 'A' becomes ready to be prepared with a new layout in preview.

**Split layer**

The two layers making up a mix layer can be split to work independently. When split, the layers will fade out and fade back in during transition between layouts. Any modifications to the layer while it is in program will be seen on the output in realtime.

**Mix background layer**

Each screen destination comes with a mix background layer that spans the entire output or wide screen. It is not possible to split the mix background layer. Content within this mix background layer can partially fill or move within this canvas. All other layers are always positioned on top of the background layer.

**Wide screen destination**

Wide screens are made up out of multiple single outputs with the same resolution connected using the same connector type. These larger connections allow for the creation of a continuous canvas. Content can be displayed anywhere within this continuous canvas without needing to be mindful of the hardware boundaries.

**Screen layer**

Screen layers allow all content to be placed anywhere on the canvas without needing to be mindful of the output boundaries. Content that spans multiple outputs will be displayed without any seams or gaps between the content. Meaning, outputs that are placed side by side, without any bezels, will look continuous. Gaps can still be created by physically separating the outputs. These layers can work in mix or split mode.

**Output layer**

Output layers allow content to be restricted within one or some of the outputs making up the wide screen canvas. This content cannot be displayed on any outputs that are not part of the output layer. If any content is partially in the output layer and partially in the rest of the canvas, then only the part within the output layer will be displayed, with the rest being cut off. These layers can work in mix or split mode.

**Scaled aux destination**

Scaled aux destinations bypass the processor on the Event Master processor. The content is sent directly from the input card to the output card without going through the internal processors. Each output card has its own scalar, allowing for 4K scaling capabilities.

**MVR (multiviewer)**

The MVR can combine all inputs and screen destinations into a customizable layout. Creating an overview of the incoming content and the content that is being displayed on outputs. These layouts are intended for internal personnel, but can be used for other reasons. MVRs can be viewed using Event Master Toolset or by sending the MVR to any desired screen destination.

2.6.2 Overview

About resources

The Encore3's processing power can be assigned differently depending on the project needs. Some unused resources can be modified or allocated differently. The following table depicts the maximum possible resource distribution:



Linking two Encore3s together does not mean that all resources are doubled. Some resources will be used to facilitate the sharing of content between the two units.

Resource type		Encore3	Linked Encore3s
Screen destinations		8	16
Single screen layers	Mix	<ul style="list-style-type: none"> • 4x mix layer¹ • 1x mix background layer¹ 	<ul style="list-style-type: none"> • 4x mix layer¹ • 1x mix background layer¹
	Split	<ul style="list-style-type: none"> • 8x split layer¹ • 1x mix background layer¹ 	<ul style="list-style-type: none"> • 8x split layer¹ • 1x mix background layer¹
Wide screen layers	Mix	<ul style="list-style-type: none"> • 4x mix screen layer¹ • 1x mix background layer¹ 	<ul style="list-style-type: none"> • 4x mix screen layer¹ • 1x mix background layer¹
		<ul style="list-style-type: none"> • 4x mix output layer² • 1x mix background layer¹ 	<ul style="list-style-type: none"> • 4x mix output layer² • 1x mix background layer¹
	Split	<ul style="list-style-type: none"> • 8x split screen layer¹ • 1x mix background layer¹ 	<ul style="list-style-type: none"> • 8x split screen layer¹ • 1x mix background layer¹
		<ul style="list-style-type: none"> • 8x split output layer² • 1x mix background layer¹ 	<ul style="list-style-type: none"> • 8x split output layer² • 1x mix background layer¹
Scaled aux destinations		2x 4K60 ³	2x 4K60 ³
MVRs		2	4
Link resources		N/A	<ul style="list-style-type: none"> • 15x transmitter • 15x receiver

2.6.3 Single screen resource allocation

Increasing the amount of mix layers

Each screen destination is equivalent to four mix layers. Meaning, any unassigned screen destinations can be used to increase the amount of mix layers.

For example, there are two assigned screen destinations with four mix layers each. By using the resources of the two unassigned screen destinations, the total available mix layers of the assigned screen destinations will be eight each.

Switching mix layers and split layers

Each mix layer can be separated into two split layers. It is also possible to merge two split layers back into a mix layer.

2.6.4 Wide screen resource allocation

Increasing the amount of layers

By default, each wide screen has four screen layers available. These four screen layers can be placed anywhere on the canvas. When this free movement is not needed, then any screen layer can be turned into output layers for each output or output group. When the free movement is needed again, then the output layers of each output or output group can be merged back into a screen layer. Switching between screen and output layers can be done at any time and as often as needed.

1. Per screen destination
 2. Per output
 3. Per Event Master output card

For example, the wide screen is made up out of three outputs. Each output will be displaying its own content that must not be visible on the other outputs. By using the resources of the four mix screen layers, each individual output can have four mix output layers. Bringing the total available mix layers to 12.

Grouping output layers

Two or more output layers can be merged to break up the continuous canvas in smaller sub regions. These sub regions will behave as a separate canvas. Mix and match output layers and sub regions to get the maximum amount of usable canvases with the maximum amount of flexibility on placement of the content.



The sub regions do not have to be continuous and can skip over outputs.

Switching mix layers and split layers

Each mix screen layer or mix output layer can be separated into two split screen layers or two split output layers. It is also possible to merge two split screen layers or two split output layers back into a single mix screen layer or a single mix output layer.

2.6.5 Linked resources

About linked resources

When two Encore3s are linked, inputs can be sent from one unit to the other. These inputs are sent over the link cables and occupy a send resource on the original unit and a receive resource on the receiving unit. Each created link will persist even if the source is no longer being sent. It is possible to manually release this link by editing the link resources. This is considered an advanced action and requires understanding of how the links are being used.

For example, An input on the host Encore3 is part of a scene on a destination of the client Encore3. Event Master Toolset will reserve a transmitter resource (TX) of the host and the corresponding receiver resource (RX) from the client. After a transition, this input is removed from the scene on a destination of the client. The link resource will become unused. However, the TX and RX on both the host and client remain occupied by that input. Ensuring the scene can be recalled at any moment.

Each **link** uses one **link resource** on **both** Encore3s.

Process overview

3

3.1	General process	30
3.2	ShowFile process	30
3.3	Installation process	31

About process overview

Best practices and a general step by step overview on how to install and use an Encore3 will be explored in the following chapters.

3.1 General process

1. **Ensure** the Encore3 can meet the input, output and image processing **needs** of the event. For more information, see:
 - “Resources”, page 25
 - “Event Master cards”, page 19.
 - “Installation requirements”, page 34.
2. **Recommended:** prepare a ShowFile using the Event Master Toolset simulator. For more information, see:
 1. “Event Master Toolset installation”, page 83.
 2. “The simulator”, page 86.
 3. “ShowFile process”, page 30.
3. **Install** the Encore3(s) at the desired location at the event. For more information, see “Installation process”, page 31.
4. **Recommended:** restore the created ShowFile to the installed Encore3(s) using any of the following methods:
 - Using the **front panel**: “Restore”, page 59.
 - Using the **web page**: “Restore”, page 72.
 - Using **Event Master Toolset**: “Restore”, page 150 or “ShowFile editor”, page 150.
5. **Setup** a local method for controlling the event:
 - Using **Event Master Toolset** software:
 1. Ensure the device meets the installation requirements. For more information, see “Setup requirement”, page 82.
 2. Install Event Master Toolset on the device. For more information, see “Event Master Toolset installation”, page 83.
 - Using an **Event Master controller**:
 - With an EC-30. For more information, see “Connecting an EC-30”, page 43.
 - With an EC-50. For more information, see “Connecting an EC-50”, page 44.
 - Using the **widget panel**. For more information, see “Creating a widget”, page 152.
 - Using a **third party controller**. For more information, see the documentation of the manufacturer.
6. **Manage** the connected sources and screen destinations with presets and/or cues in the designed views. For more information, see:
 - Using **Event Master Toolset**. For more information, see:
 - “Programming”, page 115.
 - “External devices & cues”, page 138.
 - Using an **Event Master controller**. For more information, see “Using Event Master controllers”, page 159.
 - Using the **widget panel**:
 - With the **front panel**. For more information, see “Widget panel”, page 63.
 - With the **web page**. For more information, see “Widget panel”, page 69.
 - With any **browser capable network device**. For more information, see “Using a widget”, page 155.
 - Using a **third party controller**. For more information, see the documentation of the manufacturer.

3.2 ShowFile process

1. **Optional:** restore a ShowFile⁴ using any of the following methods:
 - Using the **front panel**: “Restore”, page 59.
 - Using the **web page**: “Restore”, page 72.
 - Using **Event Master Toolset**: “Restore”, page 150 or “ShowFile editor”, page 150.
2. Assign inputs and outputs. For more information, see “Managing destinations”, page 100 and “Managing inputs”, page 103.

4. If there is no pre existing ShowFile, skip this stage.

3. Modify and/or create MVR layouts. For more information, see [“MVR”, page 112](#).
4. Create and manage scenes and/or presets. For more information, see [“Programming”, page 115](#).
5. **Optional:** create and manage cues. For more information, see [“External devices & cues”, page 138](#).
6. **Optional:** setup the Event Master controller layouts. For more information, see [“Controller”, page 146](#).
7. **Optional:** create and manage the widget layouts. For more information, see [“Widget”, page 152](#).
8. **Optional:** define the different operators that will use the setup. For more information, see [“Multi-operator mode”, page 88](#).
9. Create a sharable ShowFile as a backup using any of the following methods:
 - Using the **front panel**: [“Backup”, page 58](#).
 - Using the **web page**: [“Backup”, page 71](#).
 - Using **Event Master Toolset**: [“Backup”, page 149](#).

3.3 Installation process

1. Ensure the install location adheres to the requirements. For more information, see [“Installation requirements”, page 34](#).
2. **Optional:** install the desired Event Master cards in the Encore3(s). For more information, see [“Installing an Event Master card”, page 36](#).
3. **Optional:** mount the Encore3(s) in a rack. For more information, see [“Rack mounting”, page 37](#).
4. Connect the cables to the Encore3(s). For more information, see:
 - **Optional:** [“Control connection”, page 40](#).
 - **Optional:** [“Linking two Encore3s”, page 39](#).
 - **Optional:** [“Genlock connection”, page 41](#).
 - Connect the required inputs and outputs to the installed Event Master cards.
5. Provide power to the Encore3(s). For more information, see [“Powering the Encore3”, page 42](#).

Installation

4

4.1	Installation requirements	34
4.2	Removing an Event Master card	35
4.3	Installing an Event Master card	36
4.4	Rack mounting	37
4.5	Linking two Encore3s	39
4.6	Control connection	40
4.7	Genlock connection	41
4.8	Powering the Encore3	42
4.9	Waking the Encore3	43
4.10	Connecting an EC-30	43
4.11	Connecting an EC-50	44

About installations

Methods of installing or connecting the Encore3 will be explored in the following chapters.

4.1 Installation requirements



WARNING: Ensure that the physical environment in which the unit is installed, complies at all times with the environmental requirements summarized in this chapter. Never use the unit in case not all requirements are fulfilled. Neglecting these will damage the unit and void the warranty.

Main power requirements

- Mono phase power net with a separate earth ground.
- Maximum power input: 100-240 VAC 50/60Hz 1100W.
- The Encore3 or the rack it is mounted in must be grounded.
- One of the following types of power cords must be used.

AC Power cord with NEMA 5/15 plug up to 13 A

The wires of the power cord are colored in accordance with the following code:

- Green or yellow + green: Earth (Ground)
- Blue or white: Neutral
- Brown or black: Line (Live)

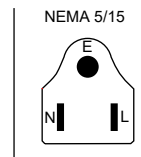

Power cord with GB 2099 plug up to 10 A

The wires of the power cord are colored in accordance with the following code:

- Green + yellow: Earth (Ground)
- Blue: Neutral
- Brown: Line (Live)

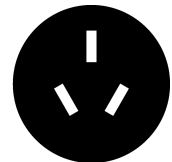

AC Power cord (mains lead) with CEE 7 plug up to 10 A

The wires of the power cord are colored in accordance with the following code:

- Green + yellow: Earth (Ground)
- Blue: Neutral
- Brown: Line (Live)

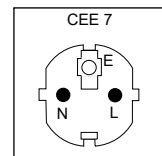

Environment conditions

Table below summarizes the physical environment in which the Encore3 may be safely operated or stored.

Environment	Operating	Non-Operating
Ambient Temperature	0°C (32°F) to 40°C (104°F)	-10°C (14°F) to 60°C (140°F)
Humidity	5% to 85% RH Non-condensed	0% to 95% RH Non-Condensed
Altitude	-60 (-197Ft) to 3000m (9843Ft)	-60 m (-197Ft) to 10000m (32810Ft)
Air cleanliness	Clean office environment ⁵	N/A
Air clearance	Air outlets: minimum 60mm (2.36in) Air inlets: minimum 60mm (2.36in)	N/A

5. Equivalent with cleanroom standard ISO 14644-1 ISO Class 9.

Rack requirements

The Encore3 weighs 31-33 kg (68-72 lbs) when fully populated with Event Master cards and is 4 rack units tall. Distribute the devices in the rack evenly to avoid hazardous situations.

Ensure at least 1,27cm (1/2 inch) of clearance between Encore3 and other devices in the rack.

4.2 Removing an Event Master card

About Event Master card removal

Unused slots will have a metal blank plate installed. The removal procedure is the same as for an Event Master card.

Prerequisites



WARNING: The Encore3 **must** be disconnected from power to avoid damaging the equipment.

Required tools

Phillips screwdriver PH2

How to remove

1. Loosen the two thumb screws (reference 1) of the desired Event Master card. Use a PH2 Philips screwdriver.

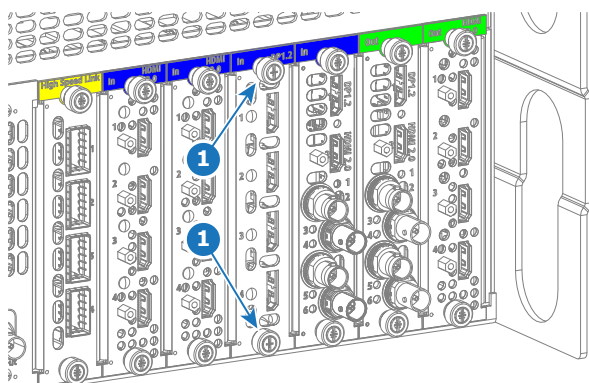

Image 4-1

2. Remove the Event Master card from the slot as illustrated.

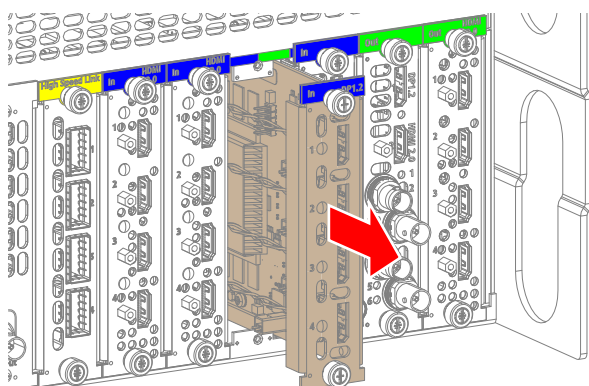

Image 4-2

3. Install an Event Master card or blank plate in the slot. For more information, see [“Installing an Event Master card”](#), page 36.

4.3 Installing an Event Master card

About Event Master card installation

The installation procedure is the same for each Event Master card. All cards can physically be installed into any of the slots, but will only work if they match the slot type. Ensure the type of card is supported by the slot before installing.



The Encore3 will ensure all installed cards have the latest compatible software version.

If a slot will not be used by any card, then installing a metal blank plate is recommended. This blank plate prevents dust or other particles from entering the Encore3 and causing damage. The installation procedure is the same as for an Event Master card.

Prerequisites



WARNING: The Encore3 **must** be disconnected from power to avoid damaging the equipment.

The desired slot can not have an Event Master card nor dust cover installed. For more information, see [“Removing an Event Master card”](#), page 35.

Required tools

Phillips screwdriver PH2

Required parts

Event Master card or blank plate

How to install

1. Insert the Event Master card in the desired slot.



Note: Verify that the slot supports the type of Event Master card being installed.

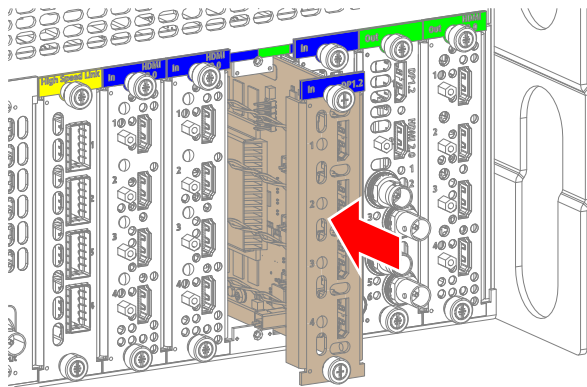

Image 4-3

2. Tighten the two thumb screws (reference 1) of the Event Master card. Use a PH2 Philips screwdriver.

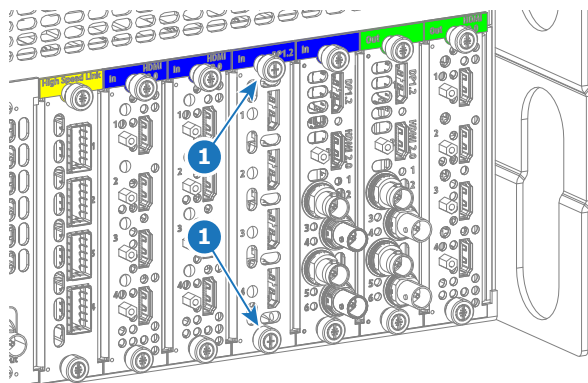

Image 4-4

4.4 Rack mounting



CAUTION: Two people are required to properly support the Encore3 while rack mounting.

About rack mounting

The Encore3 is designed to be secured to the rack from both the back side and front side. This helps keep the integrity of the unit in tact.

Required tools

- Phillips screwdriver PH2
- Torx screwdriver T20

Required parts

- Rack
- Side brackets
- Side rails
- Screws

How to mount

1. Slide the side rails into the protrusions of each rear connector protector as illustrated.

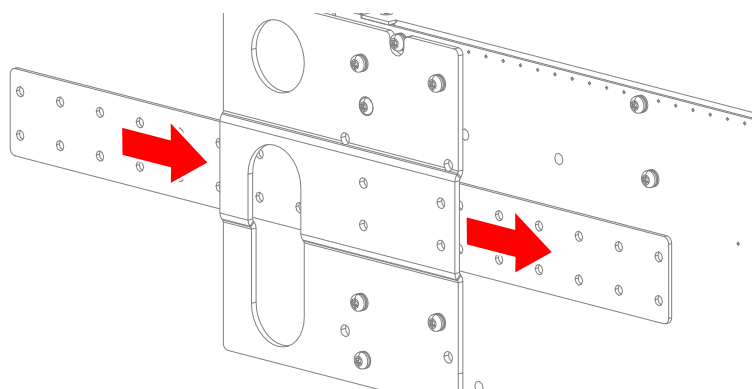

Image 4-5

2. Secure the side rails to the Encore3 as illustrated. Use a T20 Torx screwdriver.



Note: Ensure enough of the side rails sticks out. These will need to go through the side brackets.

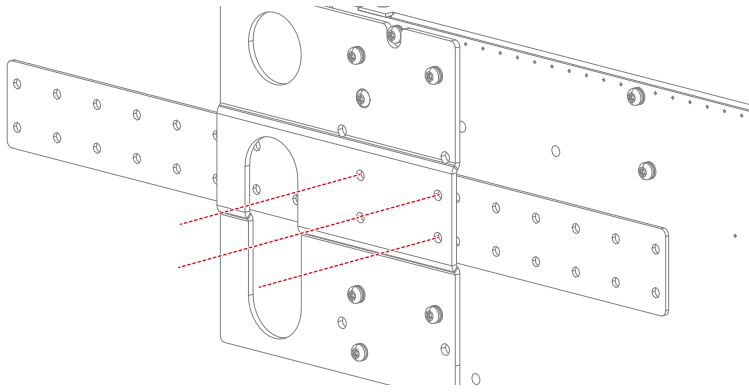

Image 4-6

3. Secure two side brackets with four screws on the desired height at the **back** of the rack. Use a PH2 Philips screwdriver.

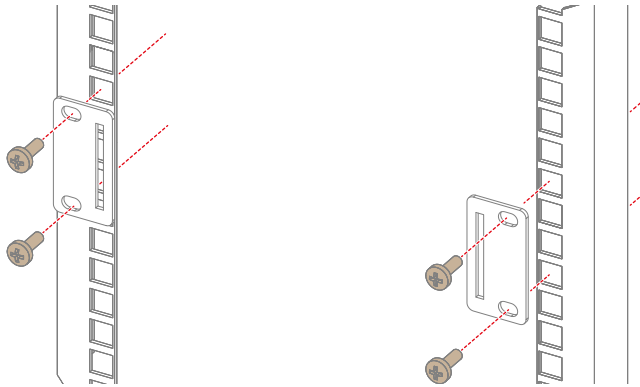

Image 4-7

4. Partially insert two screws on the lowest desired height at the **front** of the rack. Use a PH2 Philips screwdriver.



Image 4-8

5. Guide the attached side rails through the prepared side brackets at the **back** of the rack.



Caution: Lift the unit with two people, one at the front and one at the back. The unit must remain level during the entire mounting procedure to avoid damaging the frame or the rack.

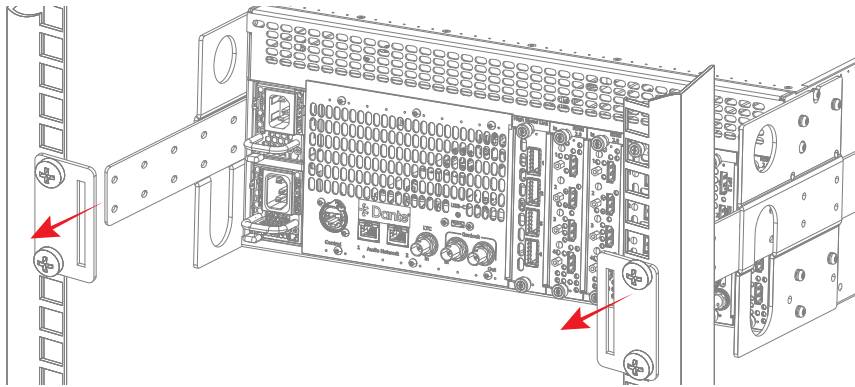

Image 4-9

- Hook the Encore3 keyholes over the two screws at the **front** of the rack and push downwards to lock the keys.

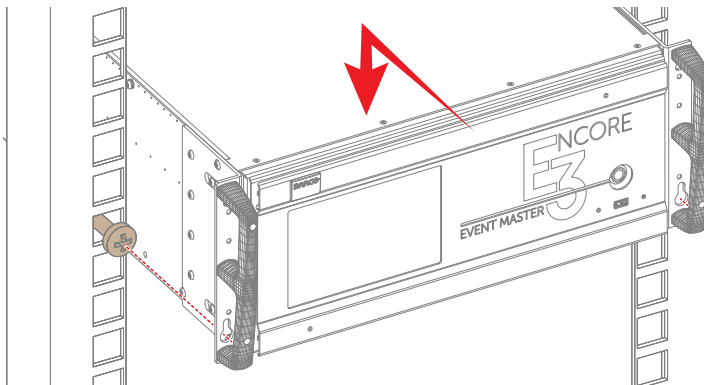

Image 4-10

The second person can let go of the backside.

- Secure the Encore3 to the rack with four screws. Use a PH2 Philips screwdriver.



Tip: Guide the screw driver through the cutouts in the handles for easy access.

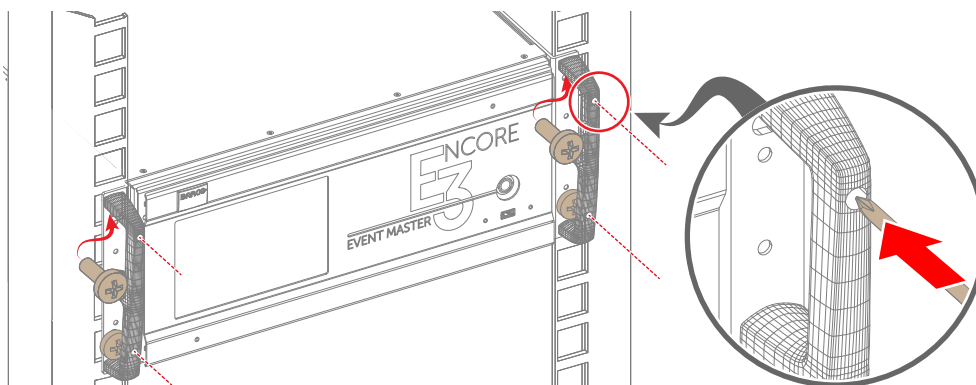

Image 4-11

4.5 Linking two Encore3s

Prerequisites

Both Encore3s must be installed in their final location or in a rack. For more information on rack mounting, see [“Rack mounting”, page 37](#).



CAUTION: Ensure the Encore3s are installed near each other. Do not tension the QSFP28 link cables.

How to link

1. Connect the two Encore3s using a QSFP28 link cable as illustrated.
 - a) Connect port '1' of the top Encore3 to port '4' of the bottom Encore3 (reference 1).
 - b) Connect port '2' of the top Encore3 to port '3' of the bottom Encore3 (reference 2).
 - c) Connect port '3' of the top Encore3 to port '2' of the bottom Encore3 (reference 3).
 - d) Connect port '4' of the top Encore3 to port '1' of the bottom Encore3 (reference 4).

 *Tip:* For a diagram of the connection, see [“System view”](#), page 110.

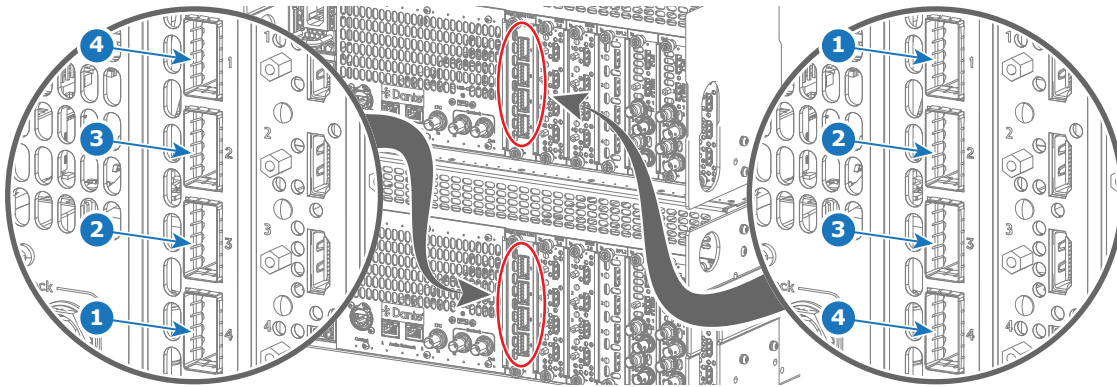



Image 4–12

2. Assign a different IP address and ID for each Encore3. For more information, see:

 *Tip:* It is recommended to set the ID of the host to '0'.

- ▶ Using the **front panel**: [“Unit ID, IP address”](#), page 49.
- ▶ Using **Event Master Toolset**: [“Configuration”](#), page 90.

4.6 Control connection



P2P

Peer-to-peer is a network connection method that links two or more devices, known as “peers”, with each other. In a peer-to-peer network all devices can function as host or client depending on the situation.



Local network

A local network is a network made up out of a combination of network switches and/or routers on site within the same IP address range.

About control connection

All control and communication with the Encore3 is done over an ethernet connection. This connection can either be P2P with a connected computer or over the local network.

Prerequisites

Power must be provided to the Encore3 before a connection can be established. For more information, see [“Powering the Encore3”](#), page 42.

How to connect

1. Plug an ethernet cable into the ‘Control’ port (reference 1).

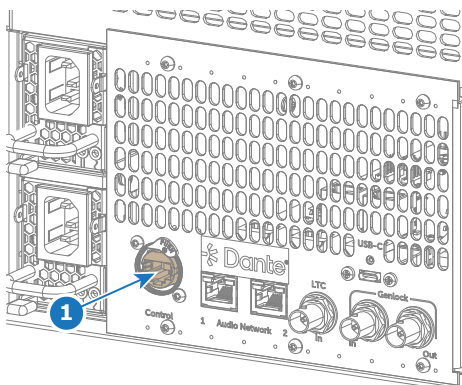

Image 4–13

An audible “click” will be heard when the ethernet cable is fully inserted.

2. Connect the ethernet cable to the local network or the computer directly.
3. Configure the Encore3 IP address using one of the following methods:
 - ▶ Through the **front panel**. For more information, see “Unit ID, IP address”, page 49.
 - ▶ Through the **web page**. For more information, see “About”, page 78.

4.7 Genlock connection



genlock

Genlock syncs the first frame of each output and locks the frames to the same clock speed. This ensures that all signals are updated together.

About genlock connection

The Encore3 can both receive or transmit a genlock signal. The ‘IN’ connection must come from a device that generates a genlock signal. The ‘OUT’ connection must go to a device that requires a genlock signal. Both connections follow the same procedure for Encore3.

How to connect

1. Connect the cable to the desired genlock connector.
 - ▶ For **receiving** the genlock signal, use the ‘IN’ connector (reference 1).
 - ▶ For **transmitting** the genlock signal, use the ‘OUT’ connector (reference 2).

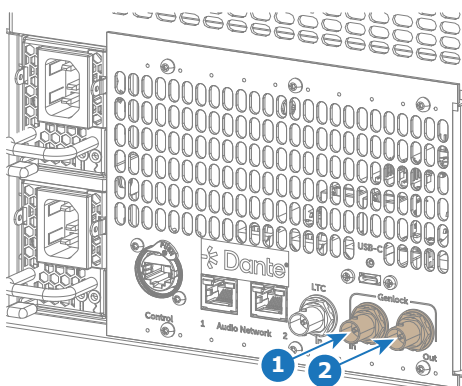

Image 4–14

2. Configure the genlock settings using Event Master Toolset. For more information, see “Genlock”, page 94.

4.8 Powering the Encore3

About powering an Encore3

The Encore3 has two redundant power supplies. Both power supplies can divide the power needs of the Encore3 equally. When one power supply fails, the other will provide the full power to keep the Encore3 running. For this reason, it is strongly advised to always connect both power supplies.

Each power supply has two indicator lights to signal its status:

- **AC input:** (reference 1)
 - **Green:** working as intended and receiving power.
 - **Amber:** a power supply error has occurred.
 - **Off:** No power is being received.
- **DC output:** (reference 2)
 - **Green:** working as intended and powering the Encore3.
 - **Amber:** a power supply error has occurred.
 - **Off:** No power is being supplied to the Encore3.

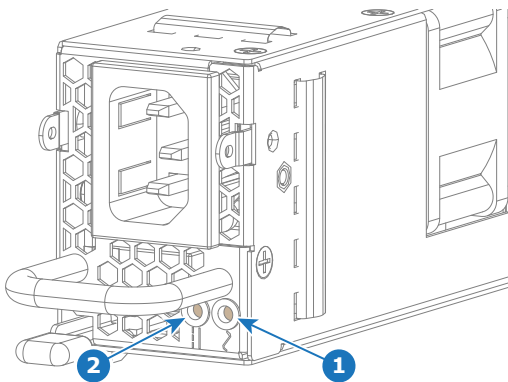



Image 4–15

- 1 AC input
- 2 DC output

How to power

1. Plug a power cable in the socket (reference 3) of each power supply.

 *Tip:* Only one connection is required.

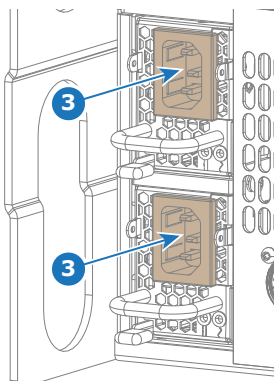

Image 4–16

2. Plug each connected power cable into a wall socket.
The Encore3 will start up. This can take several minutes.

4.9 Waking the Encore3

About waking

The Encore3 can be put in standby mode with either the front panel or Event Master Toolset. When the unit is standby mode, the indicator LED will be solid red.

For more information on how to put the Encore3 in standby, see [“Shut down”, page 65](#) or [“Reset unit”, page 96](#).

How to wake

1. Press the power button (reference 1) at the front of the Encore3.

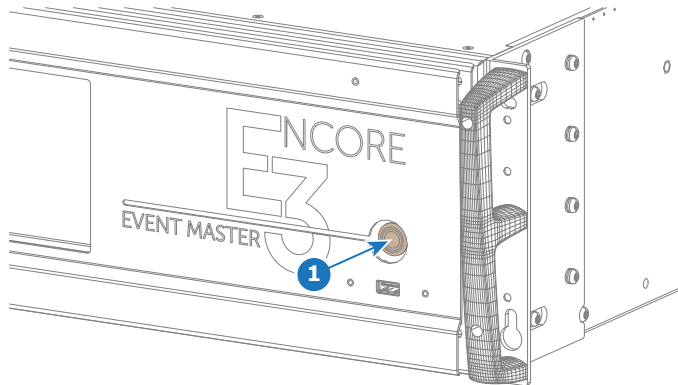

Image 4–17

The Encore3 will wake up. This can take several minutes.

4.10 Connecting an EC-30

Prerequisites

A computer with Event Master Toolset installed and a free 'USB-A' port is required to use the controller. For more information on how to install the Event Master Toolset, see [“Event Master Toolset installation”, page 83](#).

EC-30 overview

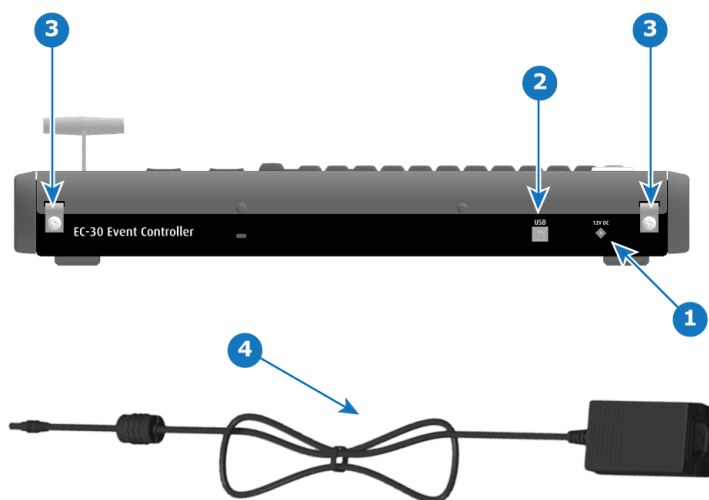

Image 4–18

- 1 Power port
- 2 USB-B port
- 3 Strain relief tabs
- 4 Power adapter

How to connect

1. Connect the power adapter (reference 4, [Image 4–18](#)) to the EC-30 power port (reference 1, [Image 4–18](#)).
2. Plug the power adapter (reference 4, [Image 4–18](#)) into a wall socket.
A light will go bounce back and forth among the 'Destination' buttons.
3. Connect a 'USB-B to USB-A' cable from the 'USB-B' port of the EC-30 (reference 2, [Image 4–18](#)) to a free 'USB-A' port of the computer.
The bouncing light will stop.
4. Run the Event Master Toolset application on the connected computer.
5. Is there a prompt to install the controller driver?
 - ▶ If **yes**, install the driver.
 - ▶ If **no**, no further actions required.

4.11 Connecting an EC-50

Prerequisites

A computer with Event Master Toolset installed and a free 'USB-A' port is required to use the controller. For more information on how to install the Event Master Toolset, see "[Event Master Toolset installation](#)", page 83.

EC-50 overview

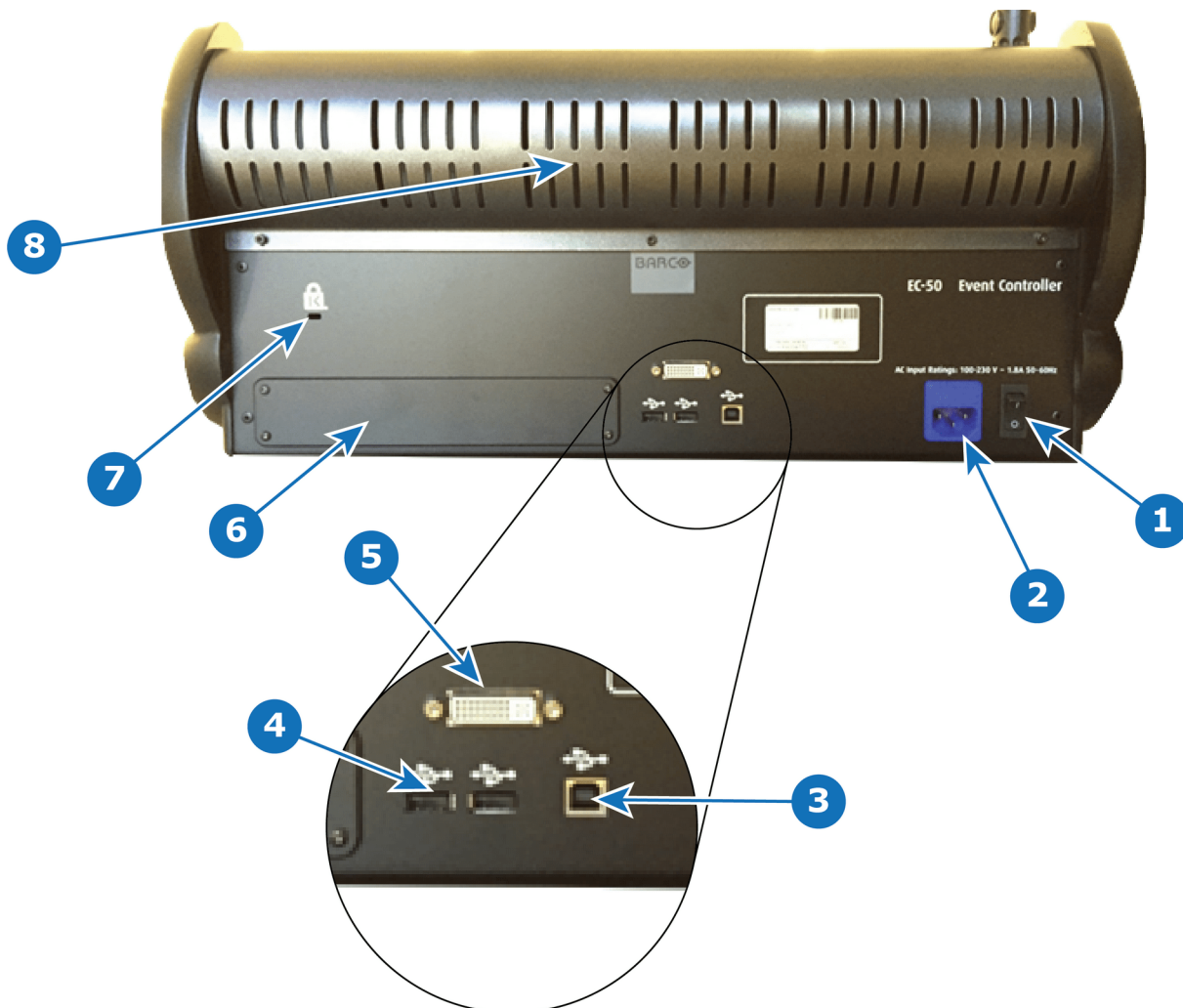

Image 4–19

- | | | | |
|---|--------------|---|-------------------|
| 1 | Power switch | 5 | DVI in port |
| 2 | Power port | 6 | Accessory slot |
| 3 | USB-B port | 7 | kensington lock |
| 4 | USB-A ports | 8 | Red effect lights |

How to connect

1. Will the controller be powered by a 250V socket?
 - ▶ If **no**, go to step 3.
 - ▶ If **yes**, go to next step.
2. Remove the plastic cover from the power port (reference 2, [Image 4–19](#)).
3. Connect the power cable to the power port (reference 2, [Image 4–19](#)).
4. Plug the power cable into the wall socket.

A light will go bounce back and forth among the *'Destination'* buttons.
5. Connect a *'USB-B to USB-A'* cable from the *'USB-B'* port of the EC-50 (reference 3, [Image 4–19](#)) to a free *'USB-A'* port of the computer.

The bouncing light will stop.
6. Connect a DVI cable from the *'DVI out'* port of the computer to the *'DVI in'* port of the EC-50 (reference 5, [Image 4–19](#)).
7. Connect a keyboard and or mouse to the *'USB-A'* port(s) of the EC-50 (reference 4, [Image 4–19](#)).
(optional)
8. Run the Event Master Toolset application on the computer.
9. Is there a prompt to install the controller driver?
 - ▶ If **yes**, install the driver.
 - ▶ If **no**, no further actions required.

Encore3 front panel

5

5.1	Introduction	48
5.2	System	48
5.3	Test pattern	57
5.4	ShowFile management	58
5.5	Widget panel	63
5.6	Reset.....	64

About this chapter

The user interface of the front panel will be explored in the following chapters.

5.1 Introduction

About the front panel

The front panel can be accessed by tapping on the touch display of the Encore3. In most cases, the home screen or the last active screen will be shown. If the front panel is locked, a warning will be displayed instead. The front panel must be unlocked before access to the settings is possible. There are two methods to unlock the front panel:

- With the Event Master Toolset. For more information, see [“Setup”, page 97](#).
- By disconnecting and reconnecting the power.

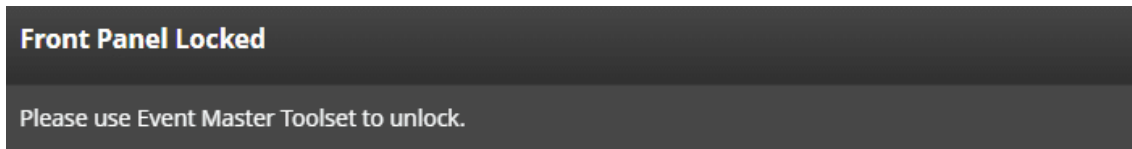

Image 5-1

About the home screen

The home screen of the front panel consists of two sections:

- **Right side:** provides general information about the Encore3 and the network configuration.
- **Left side:** tapping on the panels opens the sub menus of that category. For more information, see:
 - [“System”, page 48](#).
 - [“Test pattern”, page 57](#).
 - [“ShowFile management”, page 58](#).
 - [“Widget panel”, page 63](#).
 - [“Reset”, page 64](#).

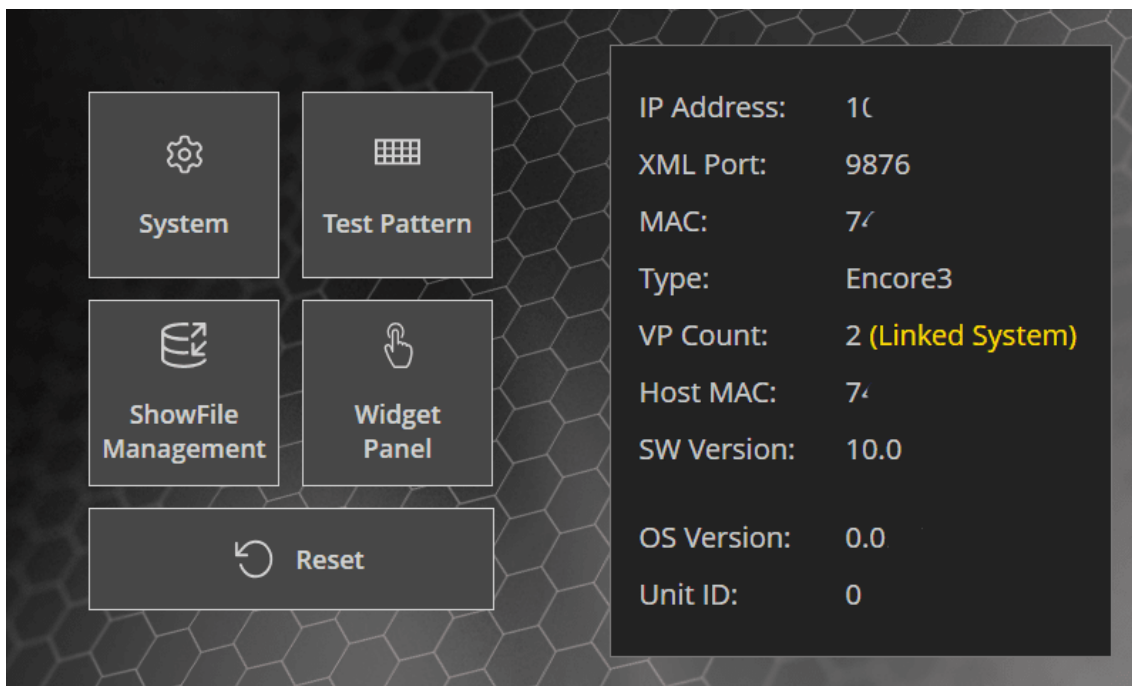

Image 5-2

5.2 System

About System

The system panel contains menus to configure the Encore3 hardware.



Image 5-3

5.2.1 Unit ID, IP address



DHCP

Dynamic Host Configuration Protocol is a protocol that manages IP addresses. When a device is connected to a DHCP network, the DHCP server will assign an unused IP address to the connected device automatically. This ensures all connected devices have unique IP addresses within the same range.

Location

System > Unit ID, IP address

About unit ID

The Unit ID is used during linking and allows software to differentiate each Encore3 with a designated number. This number can either be a '0' or a '1'. It is recommended to assign '0' to the host unit.

Tap the input field by *Unit ID* and enter the desired number using the number pad pop up.

About IP address

Two main methods for IP configuration are possible:

- **Static mode**, sets the Encore3 to a fixed IP address that is user defined.
- **DHCP mode**, means the Encore3 will request an IP address from the DHCP server of the network it is connected to.

Connection indicator

The Encore3 will automatically test the signal validity and speed of any cable connected to the 'Control' port. Results of this test will be shown in the indicator with the following states:



The indicator only signals the quality of the connected cable. Other issues can prevent the Encore3 from connecting to the network. For more information, see "[Troubleshooting abnormal Encore3 behavior](#)", page 172.

Indicator	Speed (Mbps)	Description
Red	0	No connection detected
Green	0 - 1000	Slower connection detected
Green	1000+	Faster connection detected

How to configure

1. Select the desired mode from the drop down box below *IP Mode*.
 - ▶ In case of **DHCP**, go to step 3.
 - ▶ In case of **Static**, go to next step.

The screenshot shows a network configuration screen with the following fields and values:

- Current Mode: Static
- Speed: 1000 Mbps (indicated by a green dot)
- IP Mode: Static (selected in a dropdown menu)
- Unit ID: 0
- IP Address: 10.3
- Current IP: 10.3 (greyed out)
- Static Subnet: 255.255.252.000
- DNS Server: 8.8.8.8
- Static Gateway: 10.3

Image 5-4

2. Fill out the required network information using the number pad pop up. For more information, contact the local IT department.
3. Tap on *Apply* to confirm the settings.

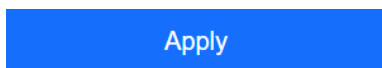

Image 5-5

The changes will be successfully applied when the IP address in the greyed out field below *Current IP* is updated.

5.2.2 Front panel

Location

System > Front Panel

About flash front panel

Flash front panel will sequentially increase the brightness of the front panel. This changing brightness can assist in locating a desired Encore3.

Toggle the flashing behavior by tapping the slider next to *Flash Front Panel*.



Image 5-6

About locking the front panel

The front panel can be locked to prevent accidental touches, unwanted modifications to the Encore3 and prevent remote access to the front panel.

Lock the front panel by tapping the slider next to *Lock Front Panel*.



Image 5-7

To unlock the front panel, use one of the following two methods:

- With the Event Master Toolset. For more information, see [“Setup”, page 97](#).
- By disconnecting and reconnecting the power.

About brightness

There are three ways to change the brightness of the front panel:

- **Using the slider:** drag the white ball over the slider until the desired brightness is reached.
- **Entering a value:** tap on the number field to enter any desired value between 10- 100.
- **Using the + and - buttons:** tap on the + to **increase** the brightness with one point and on the - to **decrease** the brightness with one point.

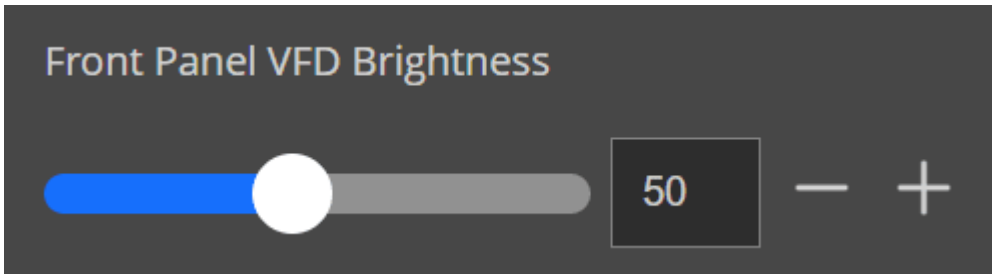

Image 5-8

5.2.3 Firmware upgrade

Location

System > Firmware Upgrade

About software upgrade

Multiple different software versions are allowed to be present on the USB stick. It is possible to install an older version of the software. Be mindful that this may cause issues.



It is recommended to create a backup before updating. For more information, see [“Backup”, page 58](#).

Required parts

8GB+ USB stick formatted in FAT32.

How to update

1. Insert the USB stick in the desired port:
 - ▶ ‘USB-A’ port (reference 1) at the front.
 - ▶ ‘USB-C’ port (reference 2) at the back.

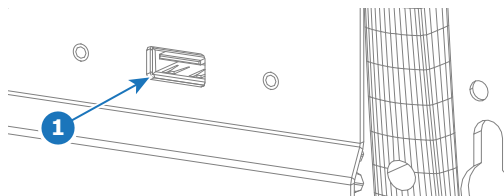

Image 5-9

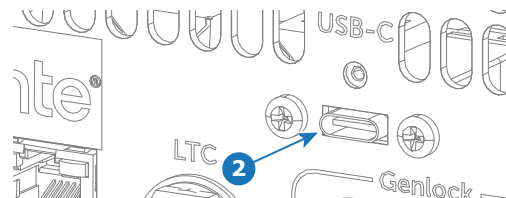

Image 5-10

A list of detected software versions will be given.

2. Select the desired software version from the list.

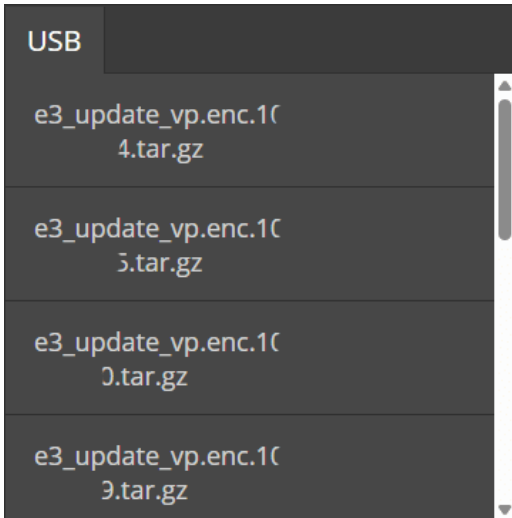

Image 5–11

3. Verify the correct software file was chosen.



Tip: An unwanted selection can be removed by tapping the x after the name

4. Is the system linked to another Encore3?
 - ▶ If **yes** and **both** units must be **updated**, tap on *Upgrade Host and Client* to upload the software to both Encore3s.
 - ▶ If **yes** and **one** unit must be **updated**, tap on *Upgrade Unit* to upload the software to the Encore3.
 - ▶ If **no**, tap on *Upgrade Unit* to upload the software to the Encore3.



Note: It is strongly advised to have both host and client on the same software version.

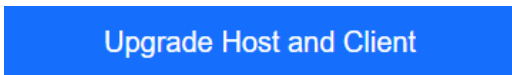

Image 5–12

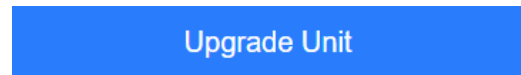

Image 5–13

The unit(s) will install the new firmware and reboot. This may take several minutes.

5. Remove the USB stick.

5.2.4 Diagnostics

Location

System > Diagnostics

5.2.4.1 About diagnostics

About diagnostics

There are three types of diagnostics available:

- **Hardware**, tests the hardware for errors and abnormalities.
- **Temperature**, tests and shows the state of the internal temperature and the fans.
- **Log file**, allows for logs and diagnostics to be saved.

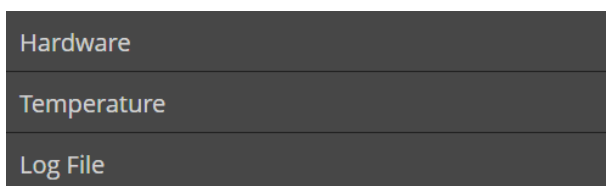

Image 5–14

5.2.4.2 Hardware diagnostics

Location

System > Diagnostics > Hardware

About diagnostics

Hardware diagnostics can be run on the entire system or on individual components of the system. These tests will use the entire capacity of the selected option. During the test the involved components will not be usable. An overview of all results and possible issues will be generated after the diagnostics have been completed. These can be stored in a log file.

Prerequisites

The Encore3 must be idle before the diagnostics can be run.

Required parts

8GB+ USB stick formatted in FAT32.

How to run

1. Must the entire Encore3 be tested?
 - ▶ If **no**, tap on *Run Diagnostics* in the same row as the desired component.
 - ▶ If **yes**, tap on *Run Full Diagnostics* in the header.

 *Note:* Do not run diagnostics during live production. Doing so will disrupt the video output.

 *Tip:* Status of the component must be *Ready* for it to be included in the diagnostics.

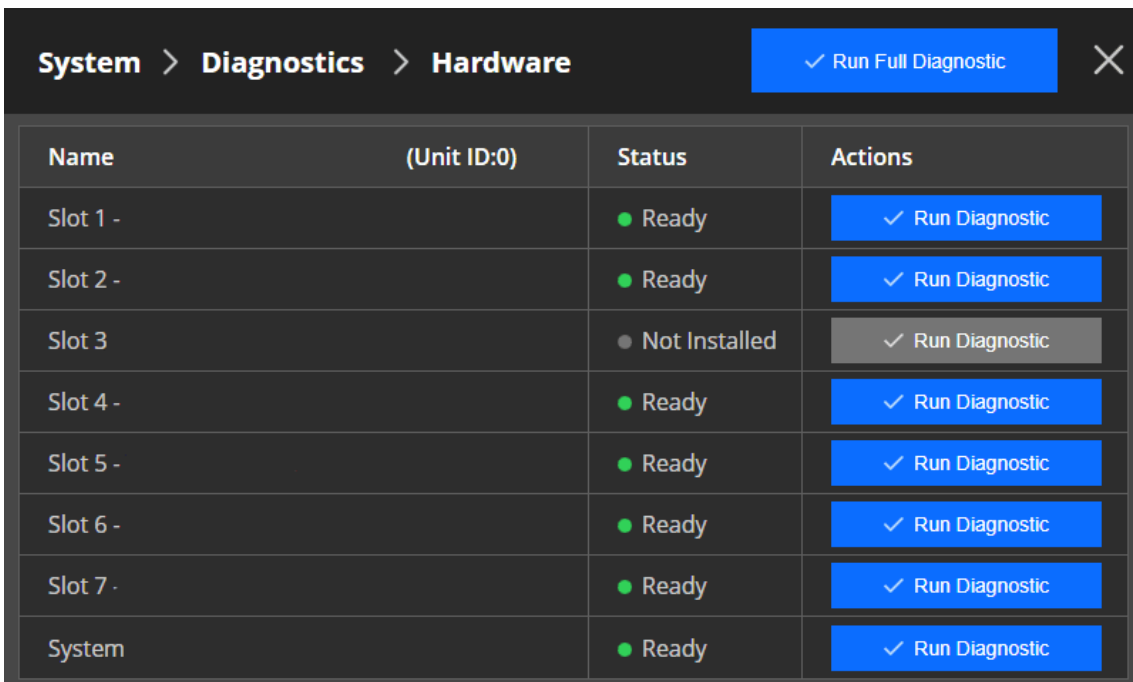

Name	(Unit ID:0)	Status	Actions
Slot 1 -		● Ready	✓ Run Diagnostic
Slot 2 -		● Ready	✓ Run Diagnostic
Slot 3		● Not Installed	✓ Run Diagnostic
Slot 4 -		● Ready	✓ Run Diagnostic
Slot 5 -		● Ready	✓ Run Diagnostic
Slot 6 -		● Ready	✓ Run Diagnostic
Slot 7 -		● Ready	✓ Run Diagnostic
System		● Ready	✓ Run Diagnostic

Image 5–15

The selected parts will be tested. This may take several minutes depending on the chosen option.

2. Go over the data in the pop up by scrolling.
3. Insert the USB stick in the desired port: (**optional**)
 - ▶ 'USB-A' port (reference 1) at the front.
 - ▶ 'USB-C' port (reference 2) at the back.

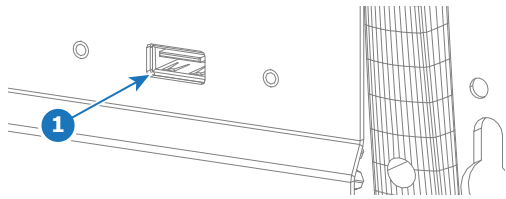

Image 5-16

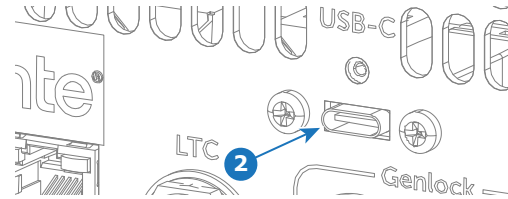

Image 5-17

4. Tap on *Save to USB* to store a copy of the diagnostics. (**optional**)

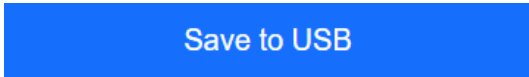

Image 5-18

5. Remove the USB stick. (**optional**)
6. Tap on *Cancel* to dismiss the pop-up



Image 5-19

5.2.4.3 Temperature diagnostics

Location

System > Diagnostics > Temperature

About temperature

The temperature diagnostics reads out the temperature and fan sensors. When no problem is found *OK* will be shown. If problems are detected *NOK* will be shown and the affected board must be replaced. For more information, see “[Removing an Event Master card](#)”, page 35.



CAUTION: If there are any temperature or fan problems with the motherboard (*MBoard*), contact Barco customer service support for further assistance. For more information, see <https://www.barco.com/en/support>.

System > Diagnostics > Temperature			
Name	(Unit ID:0)	Temperature	Fan
Slot 1 - High Speed Link		OK	OK
Slot 2 - HDMI 2.0 Input		OK	OK
Slot 3 - TriCombo Input		OK	OK
Slot 4 - DP 1.2 Input		OK	OK
Slot 5 - HDMI 2.0 Input		OK	OK
Slot 6 - HDMI 2.0 Output		OK	OK
Slot 7 - HDMI 2.0 Output		OK	OK
MBoard		OK	OK

Image 5-20

5.2.4.4 Log files

Location

System > Diagnostics > Log File

About logs

Logs only contain system information.

Required parts

8GB+ USB stick formatted in FAT32.

How to save

1. Insert the USB stick in the desired port:
 - ▶ 'USB-A' port (reference 1) at the front.
 - ▶ 'USB-C' port (reference 2) at the back.

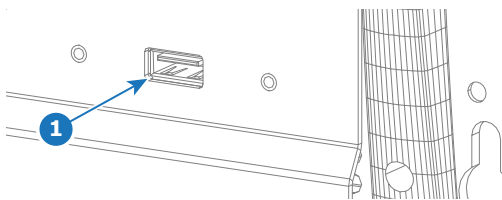

Image 5-21

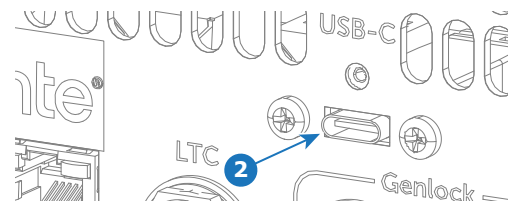



Image 5-22

2. Must stills be included in the logs?

 *Note:* Including stills will increase the size of the file.

- ▶ If **yes**, check the check box in front of *Include all stills*.
- ▶ If **no**, uncheck the check box in front of *Include all stills*.

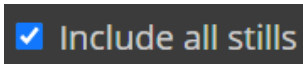

Image 5-23

3. Tap on *Save to USB* to store a copy of the log files.

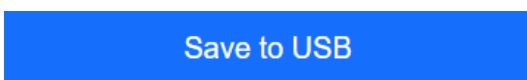

Image 5-24

The log files will be stored under the folder '*EMVlogs*' with the extension *.tar.gz*.

4. Remove the USB stick.

5.2.5 Security

Location

System > Security

Password management

Toggles whether the web page must be protected by a password.

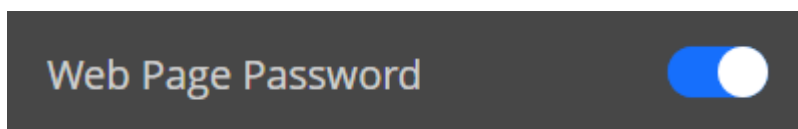

Image 5-25

When the password is enabled, a desired password can be entered in the input field under *Password* using the keyboard pop up. Tap *Apply* to confirm the entered password.



To see the entered password, click or tap on the eye icon (👁) in the input field.

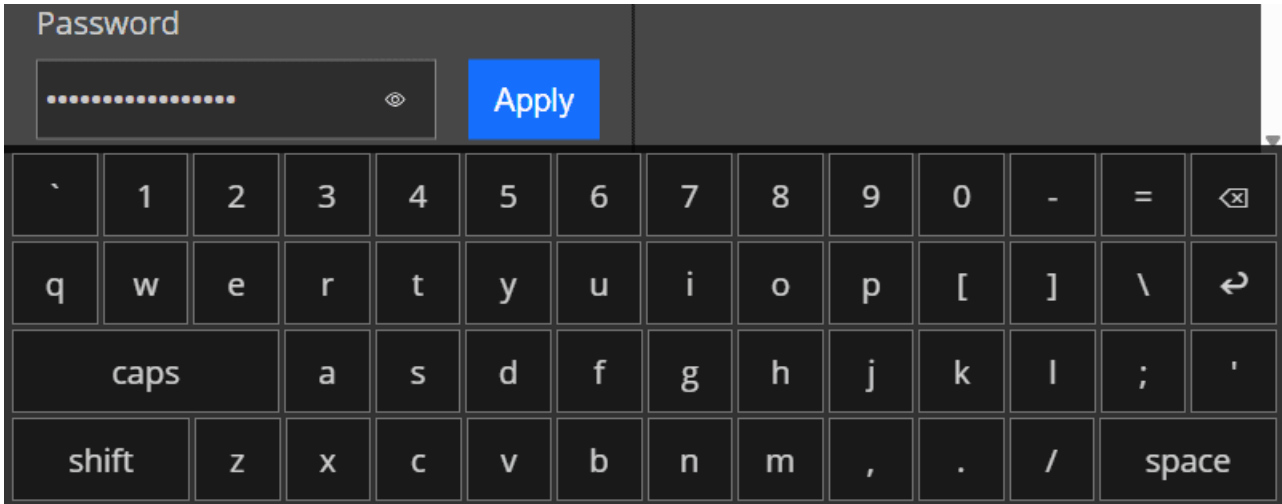

Image 5–26

API control

Toggle whether API commands must be accepted or ignored by Encore3 by tapping the slider after *External Control*.

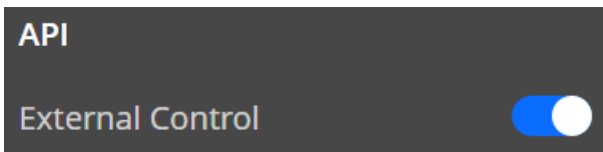

Image 5–27

Front panel lock

The front panel can be locked to prevent accidental touches, unwanted modifications to the Encore3 and prevent remote access to the front panel.

Lock the front panel by tapping the lock icon next to *Front Panel Lock*.



Image 5–28

To unlock the front panel, use one of the following two methods:

- With the Event Master Toolset. For more information, see [“Setup”, page 97](#).
- By disconnecting and reconnecting the power. For more information, see [“Powering the Encore3”, page 42](#).

5.2.6 Save

Location

System

About save

Changes to the Encore3 are applied in memory. These changes are committed to the hardware in one of two situations:

- After tapping the **Save** button.
- When the Encore3 is idle for more than one minute.

To avoid losing any modifications, it is strongly advised to save after every change.



5.3 Test pattern

About test pattern

Test pattern shows a static image that is useful for testing outputs, resolution of outputs and image quality. They can also be used to calibrate certain devices or ensure uniformity of the image across devices.

How to enable

1. Select or deselect the desired output(s) from the drop down menu below *Test Pattern*.

 *Tip:* Clicking or pressing the red x () after *Destination(s) Selected* will clear all selected outputs. Choosing the option *All Outputs* will set all outputs to selected.

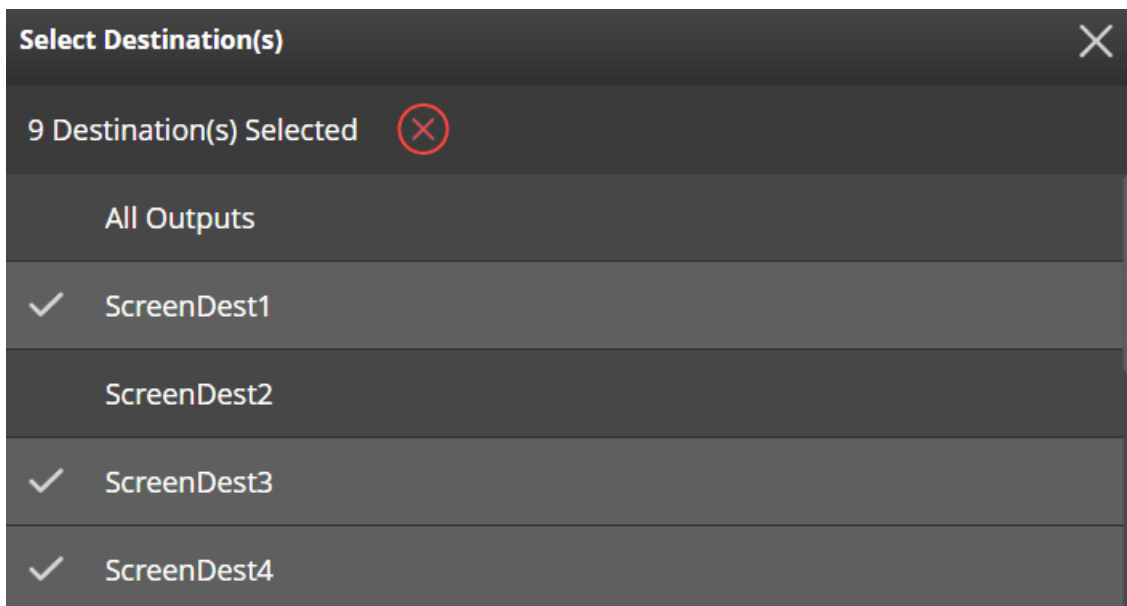

Image 5-29

2. Select a desired test pattern from the drop down menu below *Test Pattern*.

 *Note:* Test pattern *Off* will remove the test pattern.

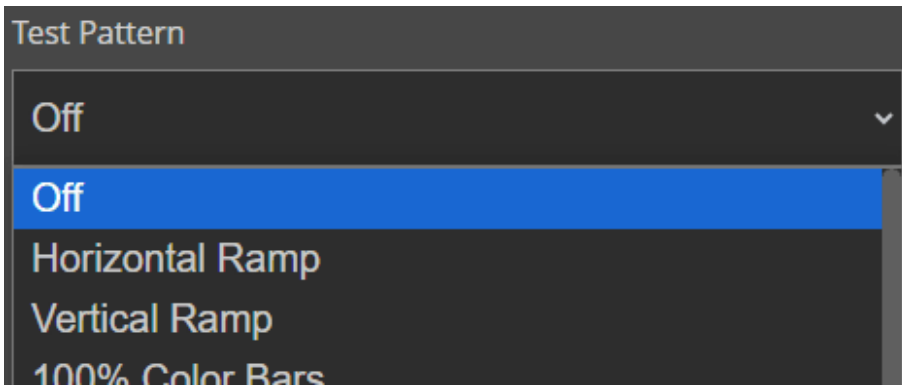

Image 5-30

3. Add additional effects on top of the test pattern by toggling the slider after the desired effect. (**optional**)

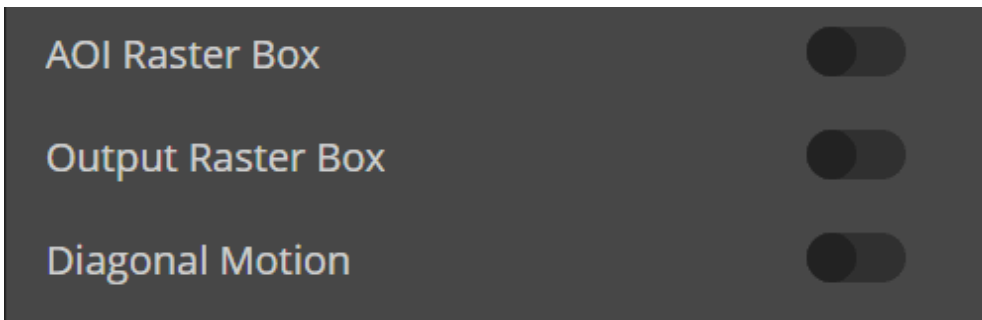

Image 5-31

4. Is the image on all outputs as desired?
 - ▶ If **no**, repeat step 2 and step 3 until the image is as desired.
 - ▶ If **yes**, go to next step.
5. Disable the test pattern using one of the following methods.
 - ▶ Select test pattern *Off* from the drop down menu below *Test Pattern*.
 - ▶ Deselect all outputs by tapping the *All Off* push button.

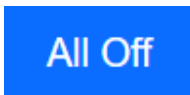

Image 5-32

5.4 ShowFile management



ShowFile

A ShowFile is a custom file format, with extension *.tar.gz*, designed to store a configuration of an Event Master system. The ShowFile can include presets, input settings, destination screens, armed destinations, custom layouts and more. The ShowFile format allows for a partial import, to mix different settings with already existing configurations.



Still images

Static graphics that are stored on the Event Masters local storage. Meaning, they will always be available once they are captured or transferred onto the unit.

5.4.1 Backup

Location

ShowFile Management > Backup

Required parts

8GB+ USB stick formatted in FAT32.

How to create

1. Insert the USB stick in the desired port:
 - ▶ 'USB-A' port (reference 1) at the front.
 - ▶ 'USB-C' port (reference 2) at the back.

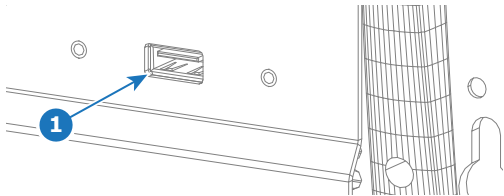

Image 5-33

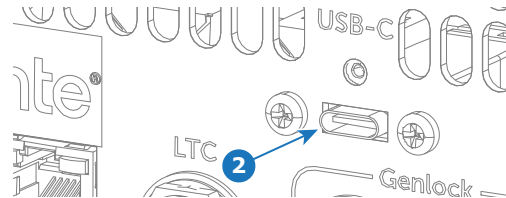

Image 5-34

2. Ensure enough free memory is available.

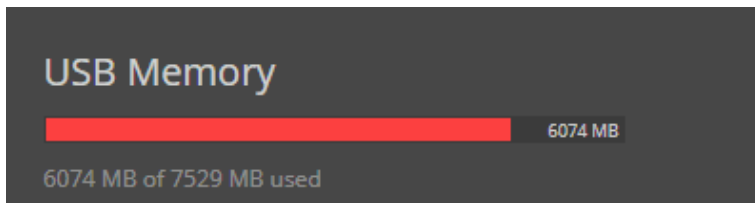

Image 5-35

3. Tap on *Backup* to create a ShowFile.



Tip: All detected ShowFiles are shown in a list on the left side.

Backup

Image 5-36

A confirmation pop-up is shown.

4. Tap on *Save* to store the ShowFile.

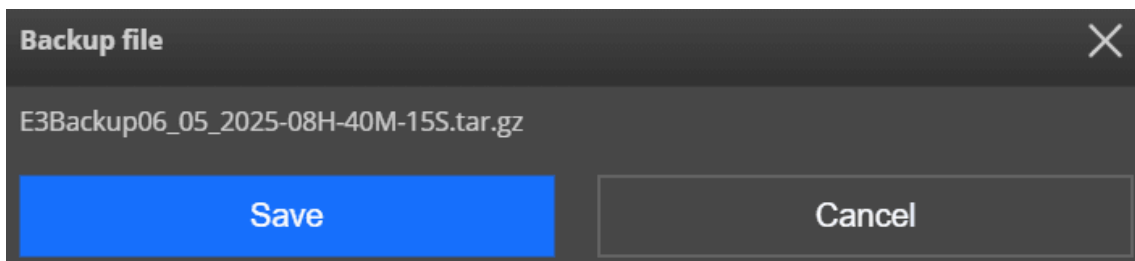

Image 5-37

The ShowFile will be stored under the folder '*EM\backup\sys*' with the extension *.tar.gz*.

5. Remove the USB stick.

5.4.2 Restore

Location

ShowFile Management > Restore

Required parts

8GB+ USB stick formatted in FAT32.

How to restore

1. Insert the USB stick in the desired port:
 - ▶ 'USB-A' port (reference 1) at the front.
 - ▶ 'USB-C' port (reference 2) at the back.

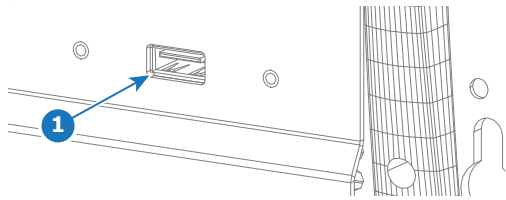

Image 5-38

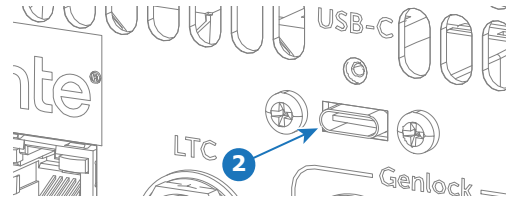

Image 5-39

2. Select the desired ShowFile from the list



Tip: ShowFiles must be in an 'EM\backup\sys' folder to be detected.

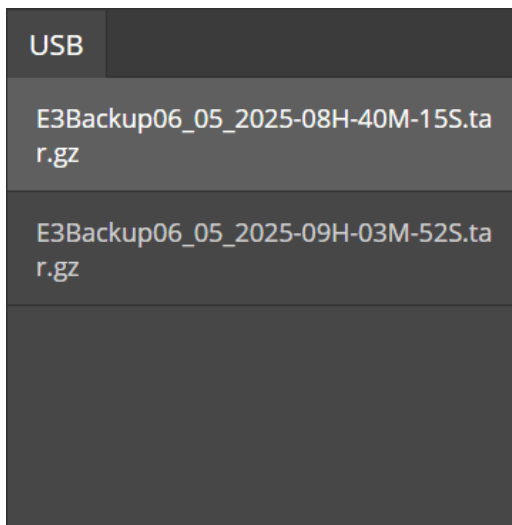

Image 5-40

3. Tap on *Restore*.



Tip: An unwanted selection can be removed by tapping the x after the name

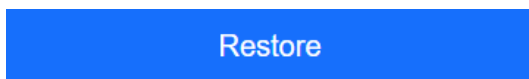

Image 5-41

A confirmation pop-up is shown.

4. Tap on *Restore & Reboot* to recall the settings from the ShowFile.



Note: All the current settings will be overwritten. This action cannot be undone.

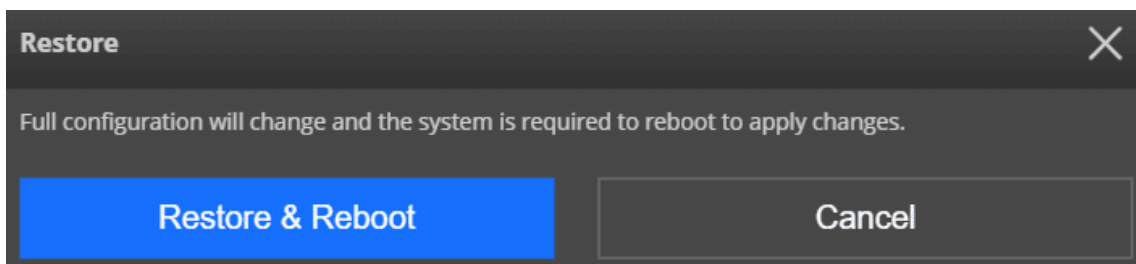

Image 5-42

The reboot may take several minutes.

5. Remove the USB stick.

5.4.3 Import stills

Location

ShowFile Management > Import All Still Images

Required parts

8GB+ USB stick formatted in FAT32.

How to import

1. Store all desired stills in a folder 'em\stills\import' on the USB stick.
2. Insert the USB stick in the desired port:
 - ▶ 'USB-A' port (reference 1) at the front.
 - ▶ 'USB-C' port (reference 2) at the back.

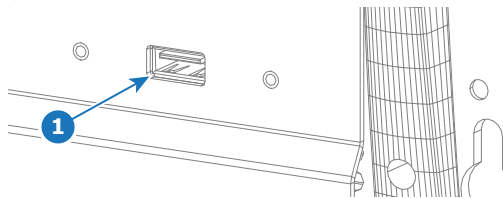

Image 5-43

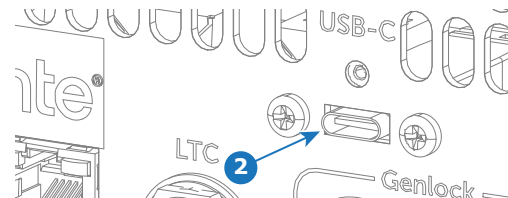

Image 5-44

3. Ensure all the desired stills are present in the list on the left.

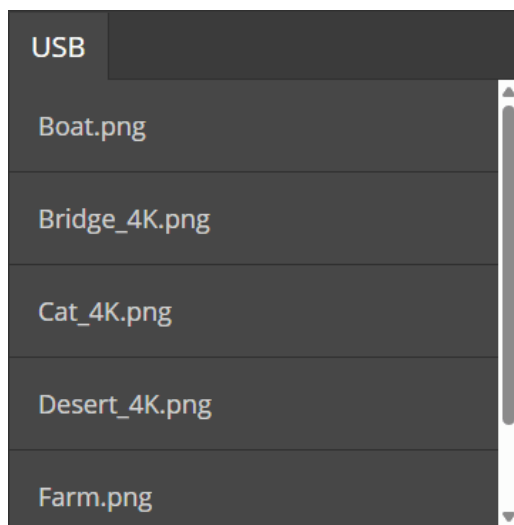

Image 5-45

4. Tap on *Import All Files* to copy the stills to the Encore3 memory.



Tip: An unwanted selection can be removed by tapping the x after the name

Import All Files

Image 5-46

Importing may take several minutes, depending on the amount and size of the stills.

5. Wait until the confirmation text is displayed.



Image 5-47

6. Remove the USB stick.

5.4.4 Export stills

Location

ShowFile Management > Export All Still Images

Required parts

8GB+ USB stick formatted in FAT32.

How to export

1. Insert the USB stick in the desired port:
 - ▶ 'USB-A' port (reference 1) at the front.
 - ▶ 'USB-C' port (reference 2) at the back.

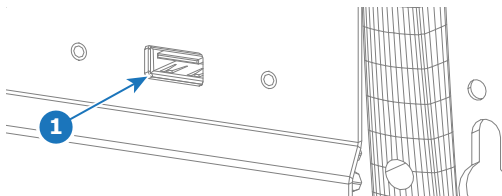

Image 5-48

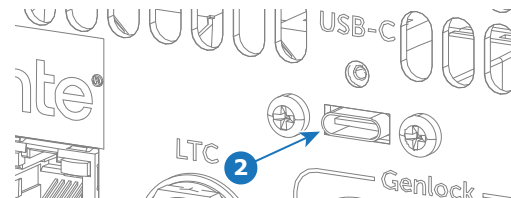

Image 5-49

2. Ensure enough free memory is available to store all stills in the list on the left side.

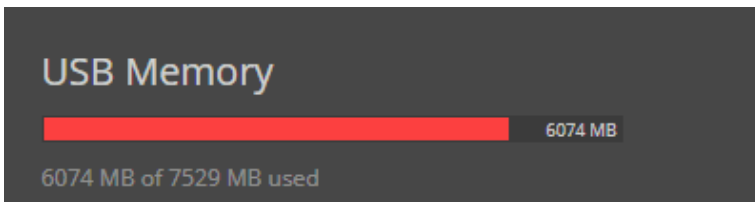

Image 5-50

3. Tap on *Export All Files* to store all stills on the USB stick.



Tip: The stills are copied to the USB stick. All stills will remain available in the Encore3 memory.

Export All Files

Image 5-51

Exporting may take several minutes, depending on the amount and size of the stills.

4. Wait until the confirmation text is displayed.



Image 5-52

The stills will be stored under the folder 'EM\stills\export'.

5. Remove the USB stick.

5.5 Widget panel



Widgets

It is possible to create custom buttons in a custom web page layout. These buttons can be given predefined functionality. Making the Event Master processor controllable from any device within the same network as the unit. These layouts are called widgets in Event Master.

About widget panel

The widget panel of the Encore3 will automatically detect any created layouts. Layouts created in the front panel resolution (800x480) can be displayed on the front panel. For more information on how to create widgets, see [“Creating a widget”, page 152](#).

How to use

1. Select the compatible widget from the list.



Note: Widgets that are not compatible with the front panel will have a notice *resolution does not match*.

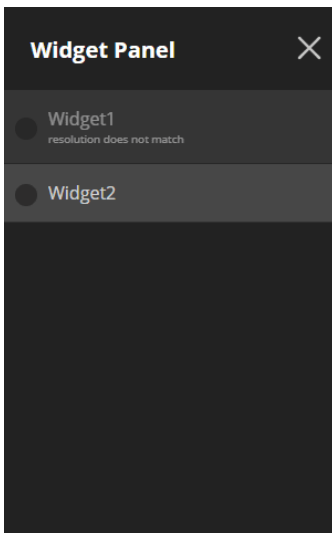

Image 5–53

A preview of the widget will be shown.

2. Tap on *Apply to full screen* to activate the widget.

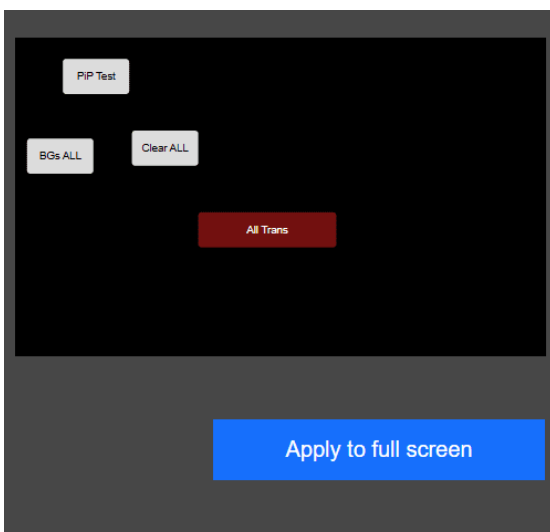

Image 5–54

3. Tap on any desired button to execute its effect.
4. Close the widget panel by tapping the x (✕).

5.6 Reset

About reset

There are various ways of resetting the Encore3. Any data or configuration lost by resetting cannot be recovered. To minimise the loss of settings, create a backup using any of the following methods:

- Using the front panel, [“Backup”, page 58](#).
- Using the web page, [“Backup”, page 71](#).
- Using the Event Master Toolset, [“Backup”, page 149](#).

5.6.1 Soft reset

Location

Reset > Soft Reset

About soft reset

Soft reset will restart the Encore3 without losing any configuration.

Tap on *Apply* to start the soft reset.

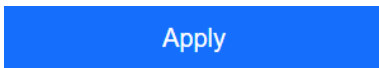

Image 5–55

5.6.2 Factory reset and keep

Location

Reset > Factory Reset and Keep

About factory reset and keep

Restores settings to their default values, except for the checked configuration related settings.

How to reset

1. Check all settings that must be kept.

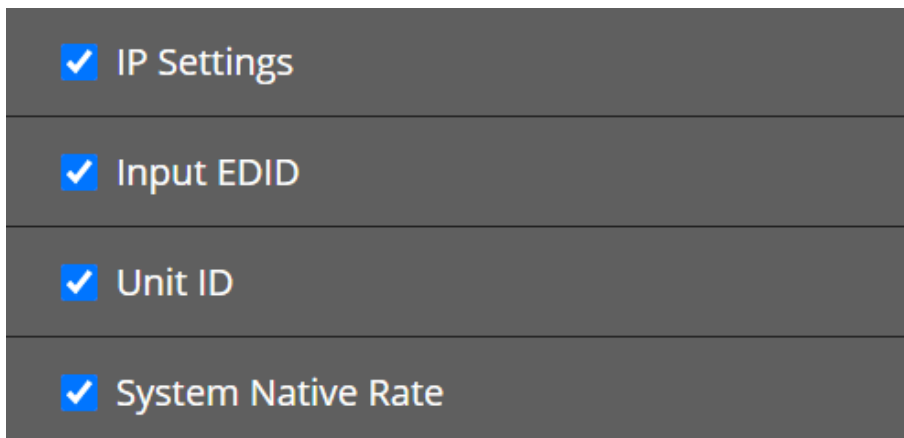

Image 5–56

2. Tap on *Apply* to start the reset.



Image 5-57

All settings, except for the selected settings, will be reset to their factory default state.

5.6.3 Factory reset

Location

Reset > Factory Reset

About factory reset

All Encore3 settings, including the IP address, will be reverted to the factory default. A full configuration of the Encore3 is required after this reset.



If any modification to the IP address was made, then remote access to the unit will be lost after the reset.

Tap on *Apply* to start the full reset.



Image 5-58

5.6.4 Shut down

Location

Reset > Shut Down

About shut down

Shut down will set the Encore3 in standby mode. While in standby the power usage of the Encore3 will decrease to 13.5W and the power button LED will turn solid red.

Tap on *Apply* to shut down the Encore3.



Image 5-59

Encore3 web page

6

6.1	Introduction	68
6.2	Accessing the web page	68
6.3	Widget panel	69
6.4	Tools.....	70
6.5	Help	76
6.6	About.....	78

About this chapter

The available settings and options of the Encore3 web page will be explored in the following chapters.

6.1 Introduction

About the web page

The web page is a website run locally on the Encore3. Any simulated instance of the Encore3 will not generate a web page.

The user interface consists out of the following sections:

- **Header:** shows the unit information and the current page.
- **Navigation side panel:** allows for navigation between different categories. The side panel can be collapsed or expanded by clicking the '<' or '>' icon on the left of the header.
- **Main window:** shows information and options related to the current page.

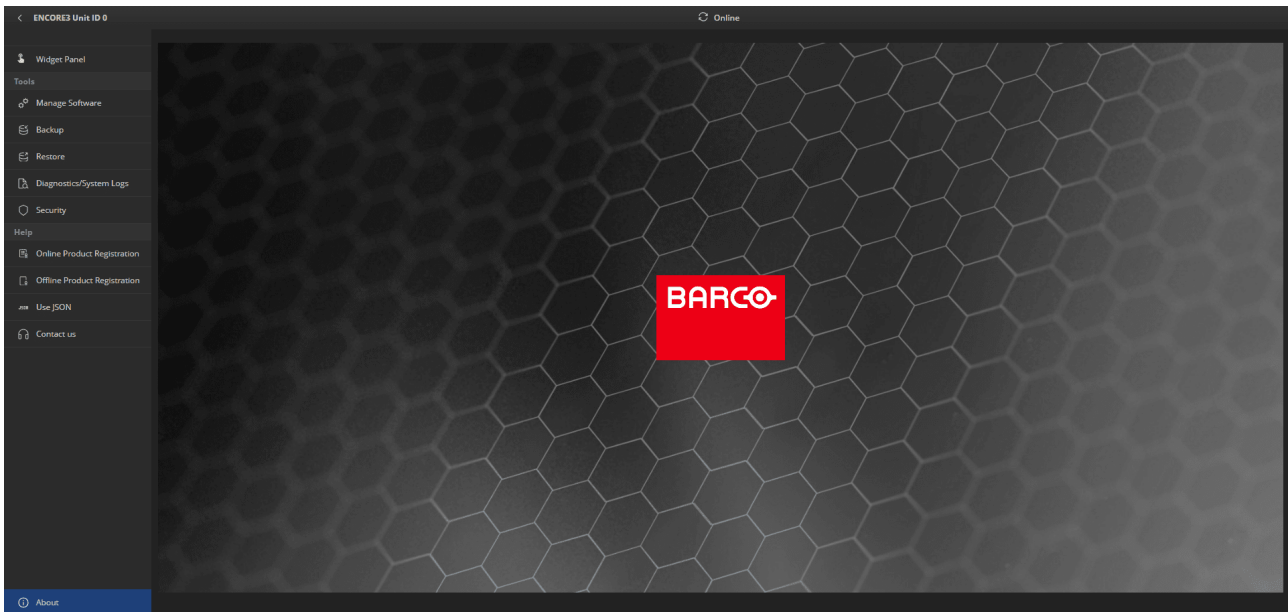

Image 6–1

6.2 Accessing the web page

Prerequisites

Connection with the control port of the unit is required. For more information, see [“Control connection”, page 40](#).



Methods of accessing the web page

The web page can be accessed using one of the following methods:

- With Event Master Toolset. For more information, see [“Unit web page”, page 156](#).
- Using a device in the same network as the Encore3.
- Using a device connected directly to the Encore3. For more information, see [“Control connection”, page 40](#).

How to access with a browser

1. Open a browser of choice.
2. Navigate to the IP address of the Encore3. For more information about the IP address, see:
 - ▶ For the front panel, [“Unit ID, IP address”, page 49](#).
 - ▶ For Event Master Toolset, [“Network”, page 151](#).
3. Fill in the password and click *Enter*. (**optional**)

 **Tip:** To see the entered password, click or tap on the eye icon () in the input field.

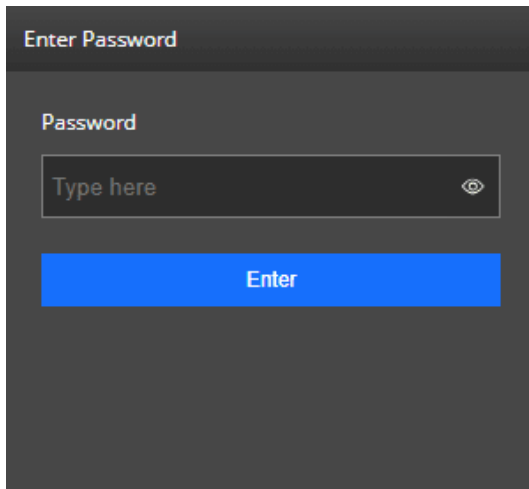

Image 6–2

6.3 Widget panel

About widget panel

The widget panel of the Encore3 will automatically load any present layouts. These layouts can then be displayed within the browser. For more information on how to create widgets, see [“Creating a widget”, page 152.](#)

How to use

1. Select the desired widget from the tiles.

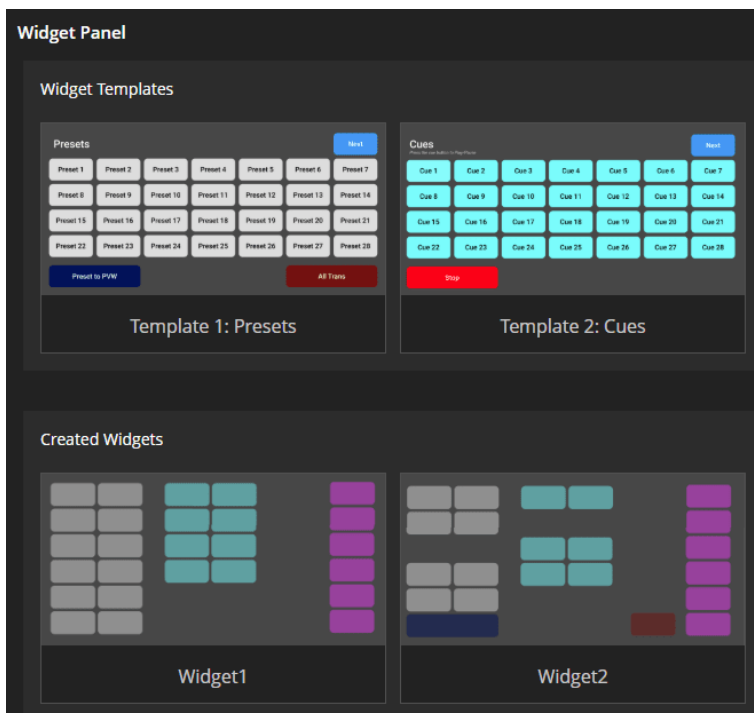



Image 6–3

2. Fill in the password of the widget panel and click on *Enter*. (optional)

 *Tip:* To see the entered password, click or tap on the eye icon () in the input field.

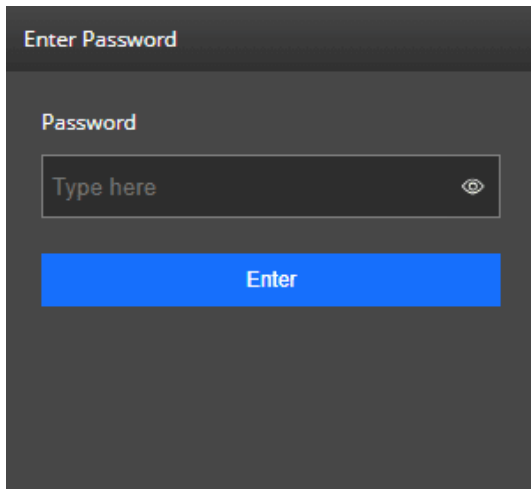

Image 6-4

The widget will be shown in its full resolution. Depending on the screen resolution of the device, scrolling may be required to see all buttons.

3. Click on any desired button to execute its effect.

6.4 Tools

About tools

The following chapters describe every menu and option under the *Tools* category.

6.4.1 Manage software

About software update

Updating the software of the Encore3 with the web page can be done in two methods:

- Using **local storage** on a connected computer.
- Using a **USB stick** plugged into the Encore3.

Multiple different software versions are allowed to be present on the USB stick. It is possible to install an older version of the software. Be mindful that this can cause issues.



It is recommended to create a backup before updating. For more information, see [“Backup”, page 71](#).

Required parts

8GB+ USB stick formatted in FAT32.

How to update from the local computer

1. Select the *Computer* tab from the table.

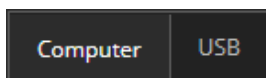

Image 6-5

2. Select the desired update file using one of the following methods:
 - ▶ Drag and drop the file in the designated area.
 - ▶ Click on the drag and drop area and navigate to the desired file.

- ▶ Navigate to the file by clicking the *Browse* button.

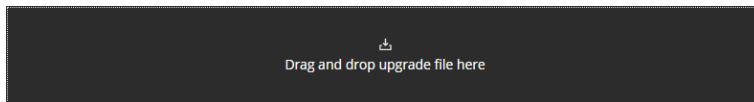

Image 6-6

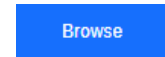

Image 6-7

The chosen file name will be written above the *Upload* button.

3. Click on *Upload* to install the software.

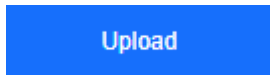

Image 6-8

The Encore3 will reboot.

How to update from a USB stick

1. Insert the USB stick in the desired port:
 - ▶ 'USB-A' port (reference 1) at the front.
 - ▶ 'USB-C' port (reference 2) at the back.

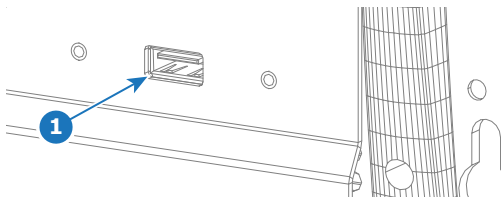

Image 6-9

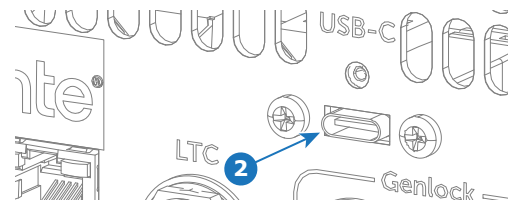

Image 6-10

2. Select the *USB* tab from the table.

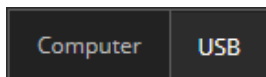

Image 6-11

3. Select the desired software version from the list.

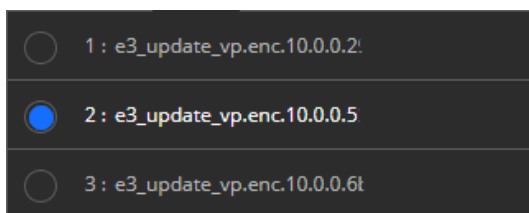

Image 6-12

4. Click on *Import* to install the software.

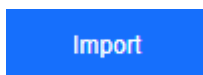

Image 6-13

The Encore3 will reboot. This may take several minutes.

6.4.2 Backup

About backup

Creates a ShowFile of the current active show. This ShowFile file can be stored on a USB connected to the front USB port or on the connected computer.

How to backup to the local computer

1. Select the *Computer* tab from the table.

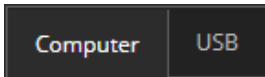

Image 6-14

2. Click on *Save*.

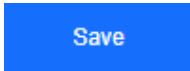

Image 6-15

A progress bar will appear at the bottom of the table.

3. Store the ShowFile in the desired location using the pop-up.
The ShowFile will be saved with the extension *.tar.gz*.

How to backup to a USB stick

1. Select the *USB* tab from the table.

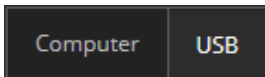

Image 6-16

2. Ensure enough free memory is available.

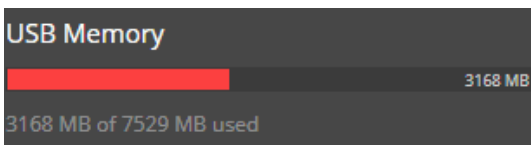

Image 6-17

3. Click on *Backup* to create a ShowFile.

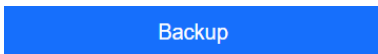

Image 6-18

A confirmation pop-up is shown.

4. Click on *Save* to store the ShowFile.

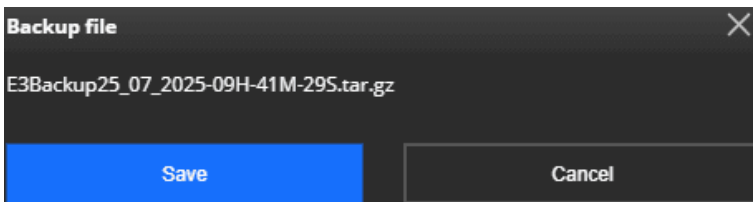

Image 6-19

The ShowFile will be stored under the folder '*EM\backup\sys*' with the extension *.tar.gz*.

6.4.3 Restore

How to restore from the local computer

1. Select the *Computer* tab from the table.

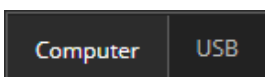

Image 6-20

2. Navigate to the ShowFile by clicking the *Browse* button.

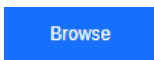

Image 6–21

The chosen file name will be shown on the right side.

3. Click on *Restore*.

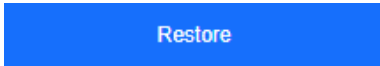



Image 6–22

A confirmation pop-up is shown.

4. Click on *Restore & Reboot* to recall all settings from the ShowFile.

 *Note:* All the current settings will be overwritten. This action cannot be undone.

 *Tip:* If only certain settings must be restored, then see [“ShowFile editor”, page 150](#).

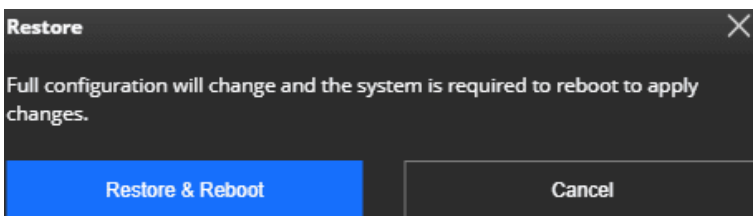

Image 6–23

The reboot may take several minutes.

How to restore from a USB stick

1. Select the *USB* tab from the table.

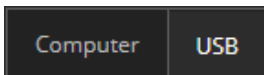

Image 6–24

2. Select the desired ShowFile version from the list.

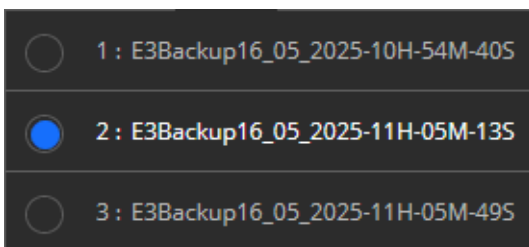

Image 6–25

3. Click on *Import* to load the ShowFile.

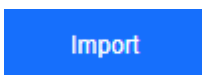

Image 6–26

The selected ShowFile will be displayed on the right panel.

4. Click on *Restore*.

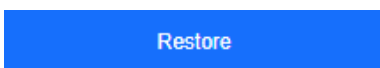



Image 6–27

A confirmation pop-up is shown.

5. Click on *Restore & Reboot* to recall the settings from the ShowFile.

 *Note:* All the current settings will be overwritten. This action cannot be undone.

 *Tip:* If only certain settings must be restored, then see “[ShowFile editor](#)”, page 150.

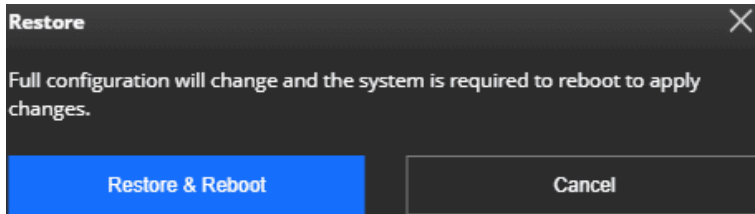

Image 6–28

The reboot may take several minutes.

6.4.4 Diagnostics/system logs

About diagnostics

Hardware diagnostics can be run on the entire system or on individual components of the system. These tests will use the entire capacity of the selected option. During the test the involved components will not be usable. An overview of all results and possible issues will be generated after the diagnostics have been completed. These can be stored in a log file.

About logs

Logs only contain system information.

Prerequisites

The Encore3 must be idle before the diagnostics can be run.

How to save logs

1. Insert the USB stick in the desired port: (**optional**)
 - ▶ ‘USB-A’ port (reference 1) at the front.
 - ▶ ‘USB-C’ port (reference 2) at the back.

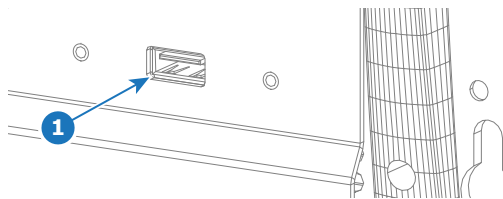

Image 6–29

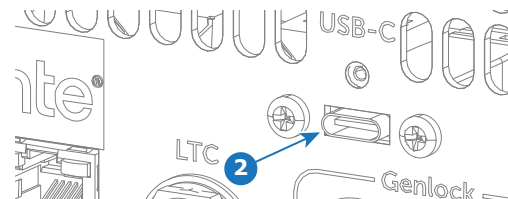



Image 6–30

2. Are the logs from the previous diagnostic needed?
 - ▶ If **yes**, go to step 4.
 - ▶ If **no**, go to next step.
3. Must the entire Encore3 be tested?
 - ▶ If **yes**, click on *Run Full Diagnostics*.
 - ▶ If **no**, click on *Run Diagnostics* in the same row as the desired component.

 *Note:* Do not run diagnostics during live production. Doing so will disrupt the video output.

 *Tip:* Status of the component must be *Ready* for it to be included in the diagnostics.

			▶ Run Full Diagnostics
Name	(Unit ID:0)	Status	Action
Slot 1 -		● Ready	▶ Run Diagnostics
Slot 2 -		● Ready	▶ Run Diagnostics
Slot 3 -		● Ready	▶ Run Diagnostics
Slot 4 -		● Ready	▶ Run Diagnostics
Slot 5 -		● Ready	▶ Run Diagnostics
Slot 6 -		● Ready	▶ Run Diagnostics
Slot 7 -		● Ready	▶ Run Diagnostics
MBoard		● Ready	▶ Run Diagnostics

Image 6–31

The selected parts will be tested. This may take several minutes depending on the chosen option.

- Must all stills be included in the log file?
 - ▶ If **yes**, check the check box in front of *Include all stills*.
 - ▶ If **no**, uncheck the check box in front of *Include all stills*.

 *Note:* Including stills will increase the size of the file.

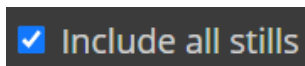

Image 6–32

- Click on *Export System Logs*.

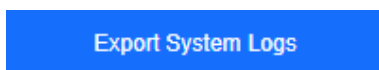

Image 6–33

- Is a USB stick connected to the Encore3?
 - ▶ If **yes**, click *Save to USB*.
 - ▶ If **no**, click *Save to computer*.



Image 6–34

A progress bar will appear at the bottom of the page.

6.4.5 Security

About password management

Passwords can be added to the following parts of the Encore3:

- The web page.
- The widget page.

To add a password prompt to the desired function, click on the slider after the password label of the desired feature.

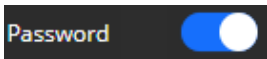

Image 6–35

When the password is enabled, a desired password can be entered in the input field under *Password*. Click on *Apply* to confirm the entered password.



To see the entered password, click or tap on the eye icon (👁️) in the input field.

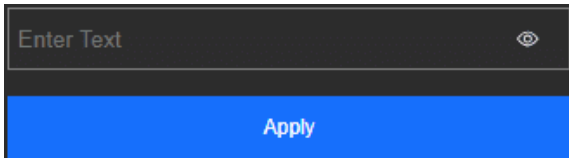

Image 6–36

Front panel lock indicator

The lock icon will indicate whether the front panel is currently locked or accessible. To lock the front panel, see [“Security”, page 55](#).

To unlock the front panel, use one of the following two methods:

- With the Event Master Toolset. For more information, see [“Setup”, page 97](#).
- By disconnecting and reconnecting the power. For more information, see [“Powering the Encore3”, page 42](#).



Image 6–37

API control

Toggle whether API commands must be accepted or ignored by Encore3 by clicking the slider after *External Control*.

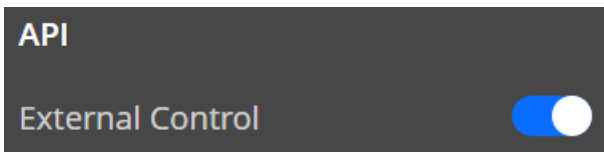

Image 6–38

6.5 Help

About help

The following chapters describe every menu and option under the *Help* category.

6.5.1 Use JSON



JSON

JavaScript Object Notation is a standardised way of writing commands or small programs to and from devices.

**REST API**

REpresentational State Transfer Application programming interface is a protocol that allows other devices to be controlled by the Encore3 or control the Encore3 with other devices.

About JSON

The Encore3 allows for remote interaction with the software through API calls in the form of JSON requests. These requests can be sent by automated systems to control or gather info about the Encore3. It is possible to test these commands one by one to get a better understanding of what they do.



These tests must actually be executed by the desired device to get a proper response. Be mindful of the state of the device and the command that is being tested.

API calls can be blocked by the security settings of the Encore3. For more information, see:

- Using the **front panel**: “Security”, page 55.
- Using the **web page**: “Security”, page 75.

About command documentation

All Barco developed devices will communicate to Event Master Toolset using the REST API. For more information, see the reference guide on the Barco website:

- For Event Master devices, see <https://www.barco.com/en/support/docs/R5919184>.
- For all other Barco devices, see <https://www.barco.com/en/support>

For commands of devices that were not made by Barco, see the documentation of the manufacturer.

How to test

1. Select a desired command from the desired category in the menu on the left.

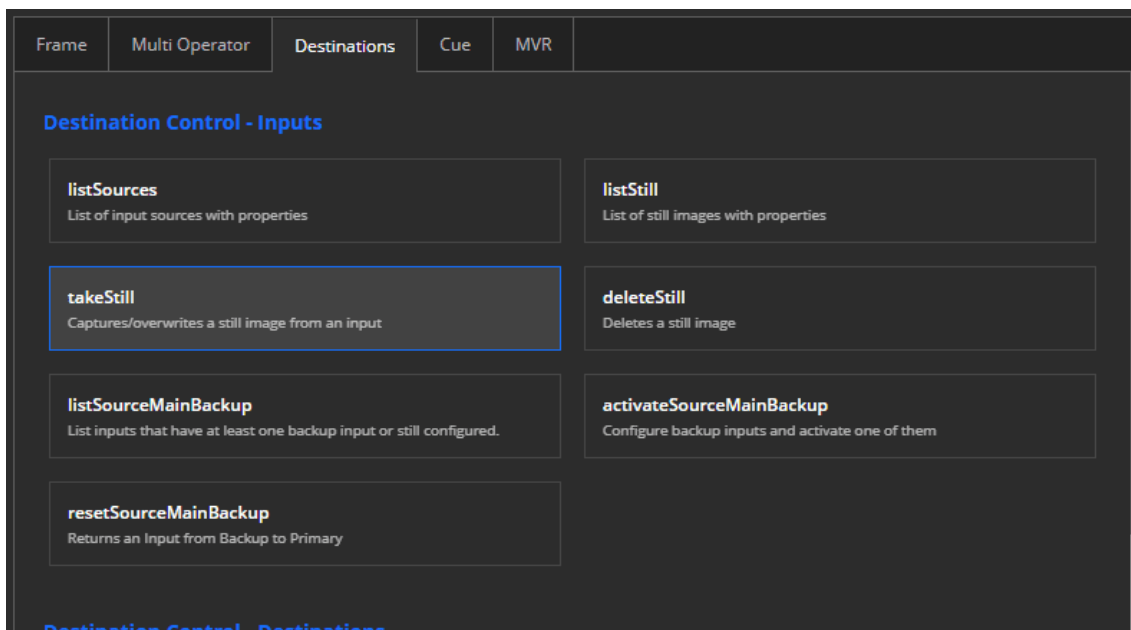

Image 6–39

The command will be entered on the right of the menu.

2. Is the IP address correct?
 - ▶ If **no**, clear the IP address by clicking the button *Clear IP Address* and enter the desired IP address. For more information on how to find the IP address, see “Unit ID, IP address”, page 49 or “About”, page 78.
 - ▶ If **yes**, go to next step.

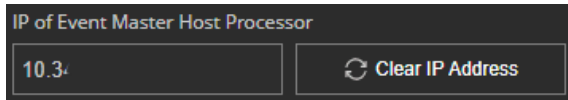

Image 6–40

3. Modify the generated command if required. **(optional)**



Tip: The command window size can be changed by dragging the bottom right corner of the window.

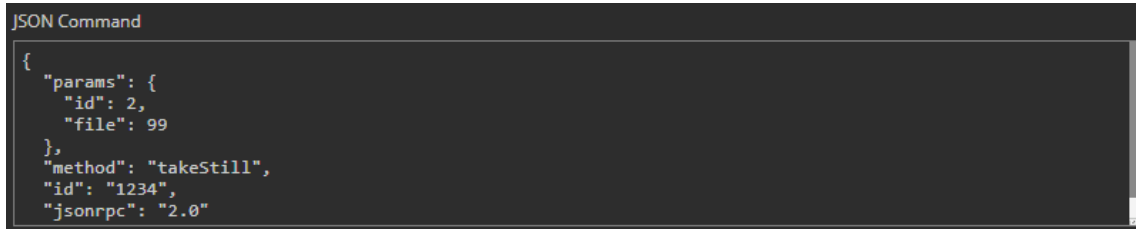

Image 6–41

4. Click on *Send Command* to run the chosen command.

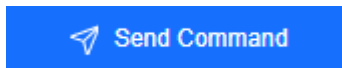

Image 6–42

The results of the command are printed in the corresponding field:

- **Error**, details what went wrong with the command.
- **Response**, shows what the command returns.
- **Success value**, shows '0' if the command was successful and no return value.

5. Must other commands be tested?

- ▶ If **no**, no further actions are required.
- ▶ If **yes**, click on *Clear Command* and go to step 1.

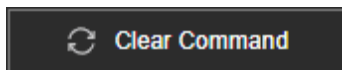

Image 6–43

6.5.2 Contact us

About contact us

Various ways of contacting and following Barco can be found here.

6.6 About

Contact info

Contact info is a text field where any text can be added. This field is intended to for the contact information of the local support responsible or technician that must be contacted in case of issues.

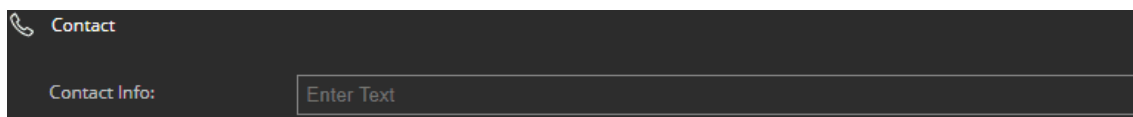

Image 6–44

System info

General information about the connected unit(s) can be found here. It is also possible to name the Encore3 or, in case of linked units, name the entire system.

Enter the desired name of the system in the input field after *System Name:* and the name of the unit in the input field after *Unit Name:*.



The name fields cannot be empty, a red outline will appear around the input field when it is empty.

Field	Value
System Name:	DOCU units
Unit Name:	Documentation Encore3
MAC Address:	74:f
IP Address:	10.2
SW Version:	0.1.0
OS Version:	0.0
Web Version:	1.0

Image 6–45

Product info

General information about the product and the privacy statement can be found here.

About IP address

Two main methods for IP configuration are possible:

- **Static mode**, sets the Encore3 to a fixed IP address that is user defined.
- **DHCP mode**, means the Encore3 will request an IP address from the DHCP server of the network it is connected to.

Network configuration

1. Select the desired mode from the drop down box after *IP Mode*.
 - ▶ In case of **DHCP**, go to step 3.
 - ▶ In case of **Static**, go to next step.
2. Fill out the required network information. For more information, contact the local IT department.

Current Mode:	Static
IP Mode:	Static
Static IP:	10.3
Static Subnet:	255.2
Static Gateway:	10.3
DNS Server:	8.1

Image 6–46

3. Click on *Apply* to confirm the settings.



Note: Changing the IP address will cause the web page to loose connection.

Encore3 web page



Apply

Image 6-47

4. Access the web page with the new IP address. For more information, see [“Accessing the web page”](#), page 68.

Event Master Toolset

7

7.1	Introduction	82
7.2	Setup requirement	82
7.3	Event Master Toolset installation	83
7.4	About the user interface	84
7.5	The simulator	86
7.6	Multi-operator mode.....	88
7.7	Multi-systems	89
7.8	Configuration	90
7.9	MVR.....	112
7.10	Programming	115
7.11	External devices & cues	138
7.12	Tally.....	144
7.13	Controller.....	146
7.14	ShowFile.....	149
7.15	Network	151
7.16	Widget.....	152
7.17	Settings	156

About this chapter

In this chapter the complementary Event Master Toolset software will be explored. A complete guide about how to navigate the software and its capabilities will also be provided

7.1 Introduction

About Event Master Toolset

Event Master Toolset is a configuration software that manages sources, outputs, presets, interactions with optional controllers and provides information about the connected Encore3. It allows the user to prepare scenes for events and execute them at desired moments.



Image 7-1

About versions

Encore3 and the products supported by

7.2 Setup requirement

About Event Master Toolset versions

Event Master Toolset has two main versions:

- Event Master Toolset 9.x and older for all legacy Event Master units.
- Event Master Toolset 10.x and higher for Encore3 units.

Event Master Toolset 10 is not able to detect any legacy units. Likewise Event Master Toolset 9 is not able to detect the Encore3 units. However, both units can be controlled as an external device with API calls from their unsupported version. For more information on API calls, see:

- For legacy units, see the user guide of the Event Master devices: <https://www.barco.com/en/support>.
- For Encore3, “External devices & cues”, page 138.

About requirements

The Event Master Toolset software must be installed on a local computer with the following requirements:

Component	Minimum	Recommended
CPU	i5 or equivalent	i7 or equivalent
Memory	8GB	16 GB
OS	<ul style="list-style-type: none"> • Windows 20H2 • MacOS 12 (Monterey) 	

7.3 Event Master Toolset installation



The Encore3 requires Event Master Toolset 10 or higher. Any lower version will not be able to detect the Encore3.

About the installation

The following instructions use a Windows 10 installation as example. The installer flow is the same for every supported operating system.

How to install

1. Download the Event Master Toolset package for the desired OS from the Barco website: <https://www.barco.com/en/support>.
 - ▶ Windows
 - ▶ Mac
2. Start the installer.
3. Read the displayed notice. Click *Next* to continue.

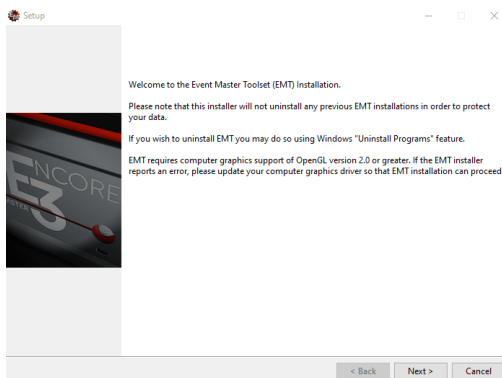

Image 7–2

4. Read and accept the Barco license. Click *Next* to continue.

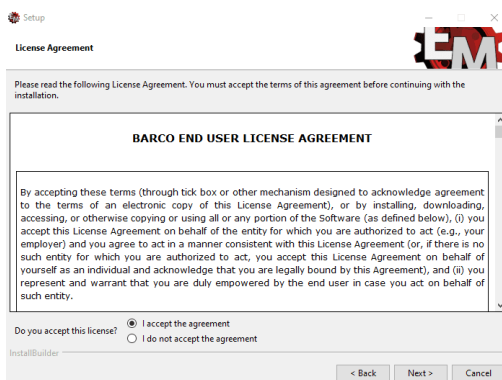

Image 7–3

5. If desired, edit the default install location and program group on the following windows. Click *Next* to continue.

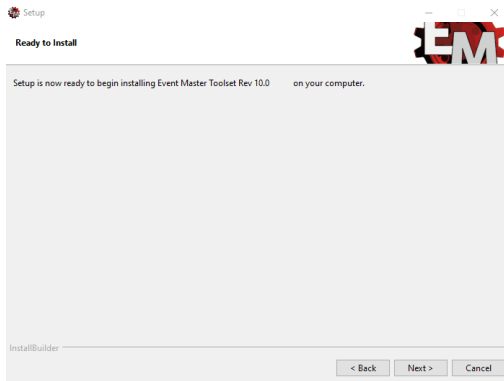

Image 7-4

The Event Master Toolset software will be installed with the desired settings.

6. Click *Finish* to complete the installation.



Tip: It is strongly advised to read the *Readme* file.

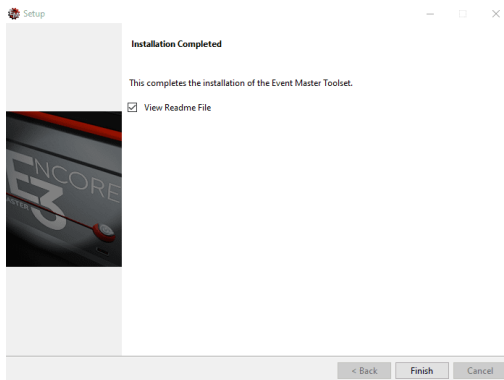

Image 7-5

7.4 About the user interface

Layout

The user interface (UI) is built up in the following sections:

- **Navigation side bar:** navigating between categories of functionality.
- **Header bar:** manages users, systems and saving.
- **Central work window:** gives a visual real time overview of the current settings.
- **Four panels:** category dependant information and options.
 - **Left panel:** list of available or detected sources or units.
 - **Top panel:** toggles between sub components or views.
 - **Right panel:** selection dependant settings.
 - **Bottom panel:** settings or information relating to the system.
- **Footer bar:** gives application related monitoring or settings.

Each of these elements purpose and functionality depends on the active category or selection. Not all elements are available in every category. Each topic will specify which menus are relevant with their '*Location*' chapter.

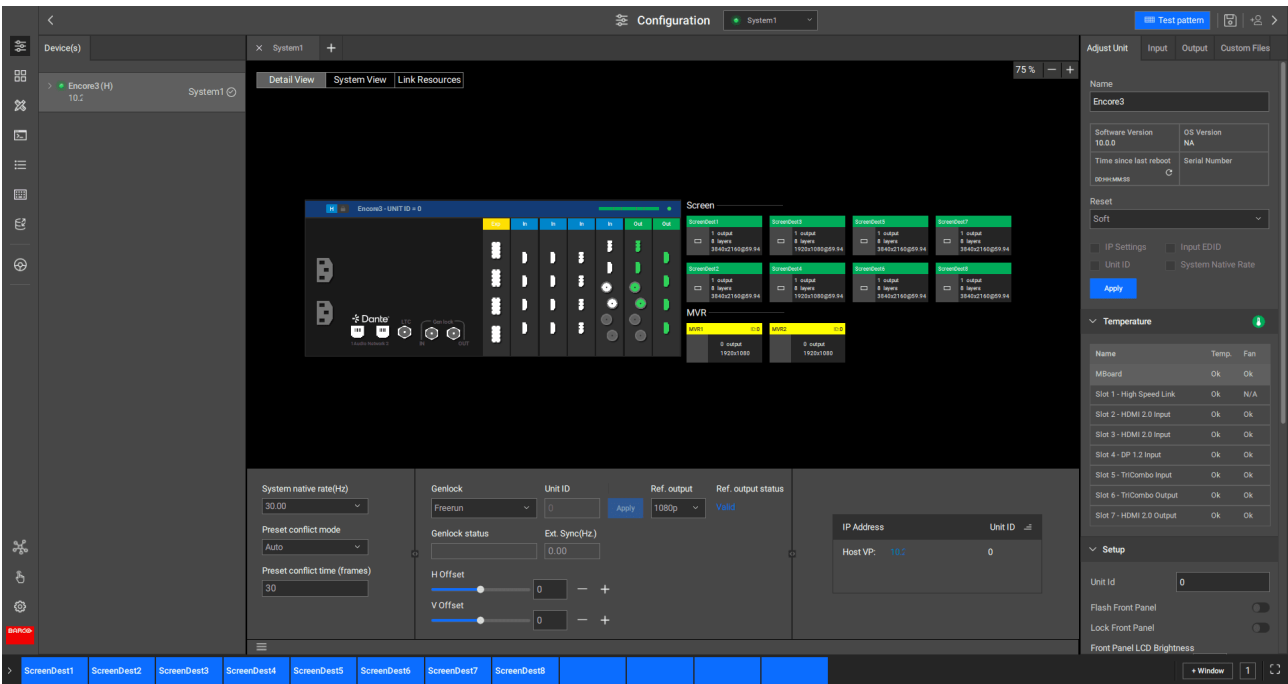

Image 7-6

Mapped destinations

The mapped destination menu shows in what order the destinations are mapped to the destination buttons of controllers. Each blue segment represents a button on the controller. Pressing the corresponding button on the controller will select the destination. For more information, see “Destination buttons”, page 160.

If the mapped destinations are not visible, click the arrow (⏪) at the left of the footer.

Notices

Modifications, errors and events will be shown and logged on the footer bar. Every modification committed to the unit will be summarised in the center of the footer bar.

The following icons can appear on the right of the footer bar:

- **Red triangle** (⚠️): there are unresolved errors or problems with the configurations or settings of the unit.
- **Grey circle** (ℹ️): a log of activities and events is available.

Clicking on the icon will open a detail window explaining the notice. It is possible to clear the list of all its entries.

It is strongly recommended to resolve all errors and warnings before clearing the list.

Multiple windows

Event Master Toolset can run a maximum of **two** windows at the same time. These menus will each get a different ID number. When any of the two windows is closed, then the remaining window will get the ID ‘1’.

Click on the + Window push button in the footer bar to open an additional window.

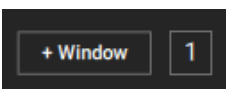

Image 7-7

Full screen

Click the full screen icon () to have Event Master Toolset take up the full screen. To exit full screen, click on the exit full screen icon ()

Zoom



Some categories allow for zooming of the content in the central work window. The zoom can either be a + () or - () icon or a drop down with percentages.



Image 7-8

7.5 The simulator



Terminal



The terminal is a command line interface that allows for direct communication between an application and the operating system. This is required to run automated scripts or commands. It is possible to follow along with what the application is doing. The information displayed can be used to identify possible problems or use as a temporary logging.

About the simulator

The simulator allows users to virtually “connect” to any Encore3 configuration. These virtual units will act like a real physical unit connected to the software. Allowing for trials of the software, creating ShowFiles, testing configurations and giving demos.

These virtual Encore3s will be running through a terminal window. Closing this terminal window will force the simulator to shut down.

How to configure

1. Navigate to the simulator using one of the follow methods:
 - ▶ In the **navigation side bar**, click on the *Simulator* icon ()
 - ▶ In the **central work panel** of *Configuration* () , click on the *Configure Simulator* push button (reference [Image 7-9](#)).

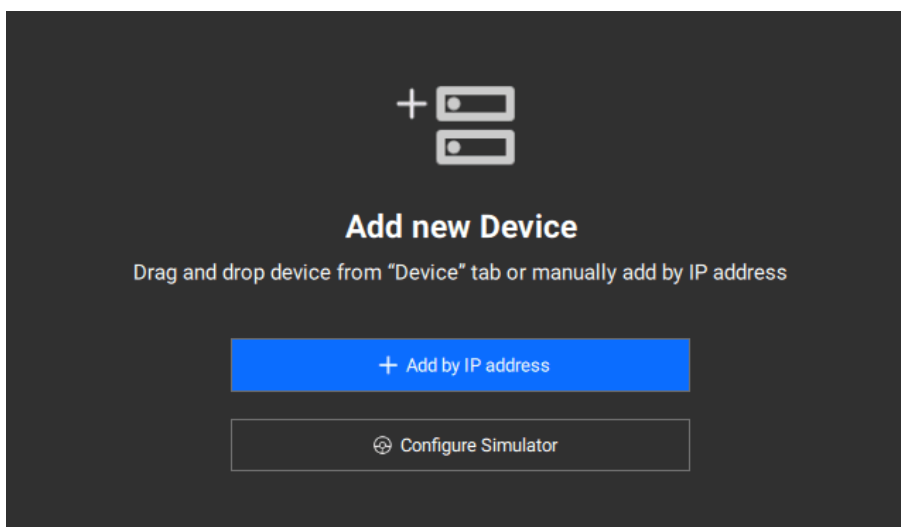



Image 7-9

2. Setup the desired starting configuration in the left panel.

- a) Add additional unit(s) by clicking the plus icon (+). (**optional**)
- b) Select the default configuration for each unit by clicking the drop down menu after *Frame*.

 *Tip:* Any unwanted frames can be removed by selecting the entry and click the trash icon (🗑️).

 *Tip:* If the left panel is not visible, click the arrow (➡) at the top left.

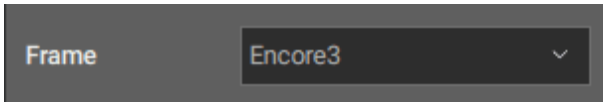



Image 7–10

3. Is the desired configuration different from the chosen default configuration(s)?
 - ▶ If **no**, go to step 5.
 - ▶ If **yes**, go to next step.
4. Create a custom configuration using one of the following methods:
 - ▶ Select the slots that must use the same card type and click *Assign* on the desired card.
 - ▶ Drag the desired card from the bottom panel onto the desired slot in the preview.

 *Note:* At least one input and output card are required.

 *Tip:* If a specific card has more than one variant, switch between the variants by selecting the radio button in front of the desired type.

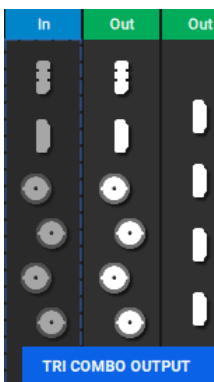

Image 7–11

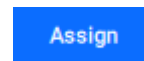



Image 7–12

5. Must the configurations of the previous simulator be loaded?
 - ▶ If **yes**, click on *Launch Simulator* to load the previous configuration.
 - ▶ If **no**, click *Reset & Launch Simulator* in the left panel to start using a new simulator.

 *Tip:* Any open simulator can be closed at any time by clicking the *Close Simulator* button.

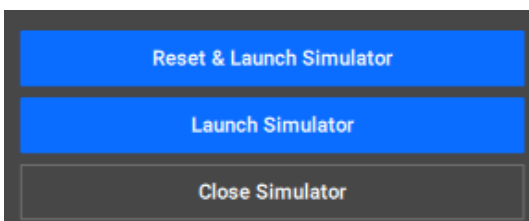

Image 7–13

A terminal will be opened in the background.

6. Start using the Event Master Toolset as usual. For more information, see the following chapters. From here on the manual will refer to the simulated unit(s) as if it is a real unit.

7.6 Multi-operator mode

About multi-operator

Event Master Toolset allows for multiple operators to work on the same system at the same time from different computers. Each operator is assigned to an account with the relevant presets and screen destinations available. These operator accounts are managed from a password protected super operator. This super operator has access to all presets and screen destinations.

How to configure

1. Click on the *Configure Multi-Operator* icon () in the header.
the *Multi-Operator* window will be shown.
2. Configure the desired operators in the multi-operator window.
 - a) Click on the slider before *Enable/Disable* to toggle the active operator accounts.
 - b) Enter a unique name for each operator under the *Operator* label.
 - c) Enter a minimum preset number on the left input field and a maximum preset number on the right input field under *PresetRange(max. 1000)*.
 - d) Select all the desired destinations using the drop down under *Assign Screen Destination(s)*.



Tip: It is possible for multiple operators to share access of screen destinations or have an overlap of available presets.



Tip: Provide clear names that reflect the intended purpose.

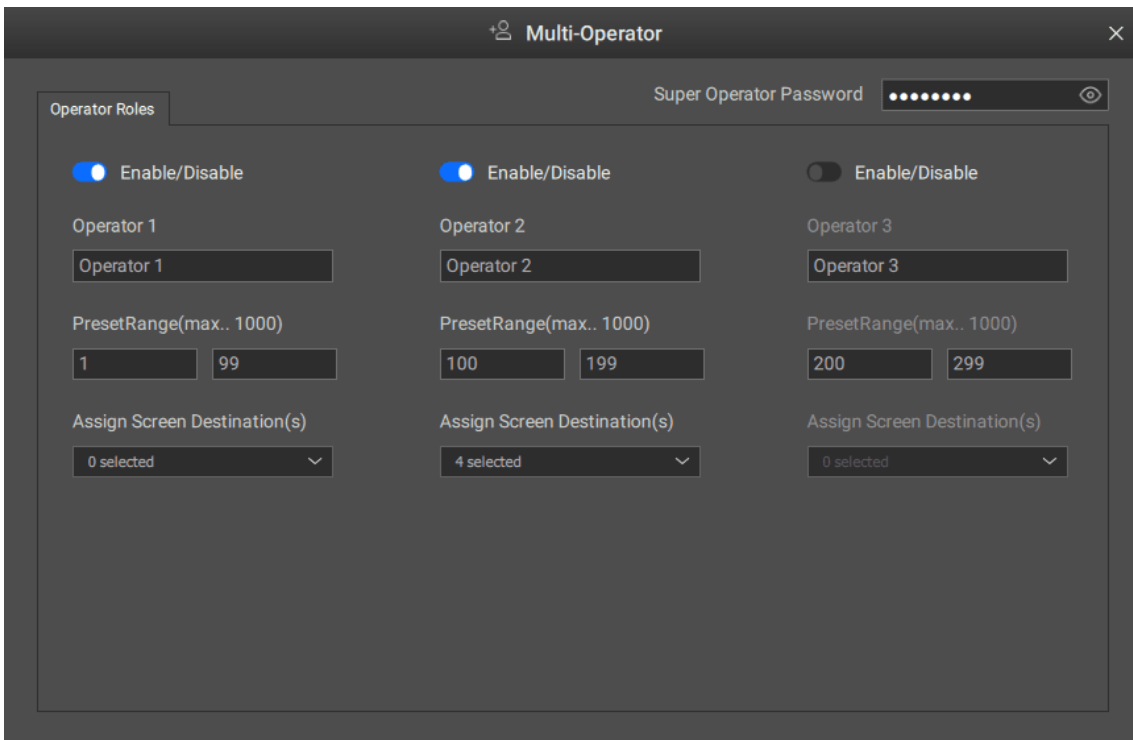

Image 7–14

3. Change the default super operator password in the input field after *Super Operator Password*.



Tip: To see the entered password, click or tap on the eye icon () in the input field.



Image 7–15

4. Close the *Multi-Operator* window.

The name of the currently active operator will be shown in the header.

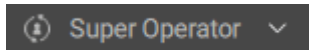

Image 7-16

5. Select the desired operator from the drop down in the header on each Event Master Toolset client.



Note: The super operator requires a password when selected. Enter the password in the input field and click *Login*.

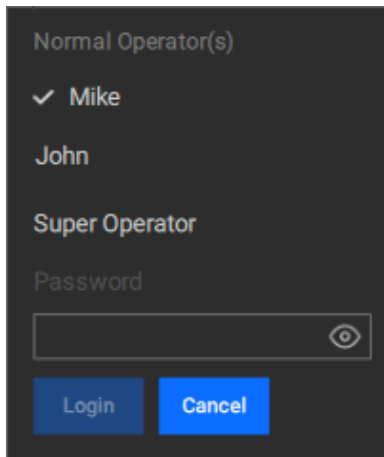

Image 7-17

Event Master Toolset will grey out all menus, destinations and presets that cannot be used by the selected operator.

7.7 Multi-systems



System

Event Master Toolset uses systems to define which hardware is being used for a certain configuration. When creating a system, hardware is being added and linked to the system name. This allows the software to remember which hardware belongs to which configuration, even when the hardware is no longer present.

About multi-systems

Event Master Toolset can seamlessly switch between multiple systems. Up to four different systems can be connected to Event Master Toolset at the same time.

How to switch

1. Select the desired system from the drop down in the header after the current menu name.



Tip: Active systems will have an active icon (🟢) before the name. If there is a version mismatch in the active system, then the icon will become amber (🟡).

Offline systems or systems that cannot be reached will have an inactive icon (🔴) before the name.

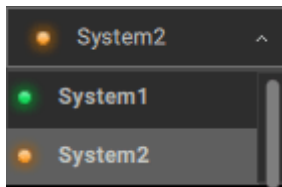



Image 7–18

The current open category will refresh with info from the selected system.

7.8 Configuration

About this chapter

The configuration tab () lets the user configure the system's general connections by allocating resources, modifying settings and more.

The possible configuration settings and features will be explored in the following chapters.

7.8.1 System creation

Location

Navigation side bar: *Configuration*

About system creation

Each created system is added to the multi-system list in the header. For more information on how to switch between systems, see [“Multi-systems”, page 89](#).

If a unit is already connected to a system then the left panel will show a label with the name of that system. A checkmark in a circle will be added for systems that are currently connected to Event Master Toolset.

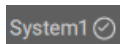



Image 7–19

About unit(s)

When starting up, Event Master Toolset scans the connected network for compatible units. Previous connections and IP addresses are also recalled. These two are combined into a list in the left panel, where the following identifying information is displayed:

- Connection indicator.
 - **Green indicator** (): the unit can be reached and is ready to be added.
 - **Red indicator** (): the unit is offline or not connected.
 - Name of the detected unit followed by the host-client relationship in brackets.
 - **Host unit** (H): the unit is configured as a host.
 - **Client unit** (C): the unit is configured as a client.
 - Last known or current IP address of the unit.
 - Name and connection status of the system the unit is a part of, if applicable.
- Note:** It is not possible to add the same unit to multiple systems.

Clicking on the expansion arrow () will show the full details of the unit.

How to create

1. Must a new system be created?
 - ▶ If **yes**, click on the + in the top panel and go to next step.
 - ▶ If **no**, go to next step.

-  **Note:** It is not possible to add the same entry to multiple systems. The overview shows what units are already connected to a system.

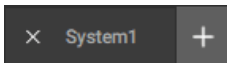

Image 7-20

2. Are the desired unit(s) visible in the left panel?
 - ▶ If **yes**, drag the desired entry from the left panel and drop it in the central work window. Go to step 5.
 - ▶ If **no**, go to next step.
3. Which type of system must be added?
 - ▶ For a **simulator**, click on *Configure Simulator*. For more information on how to configure the simulator, see [“The simulator”](#), page 86.
 - ▶ For **working hardware**, click on *+ Add by IP address* and go to next step.

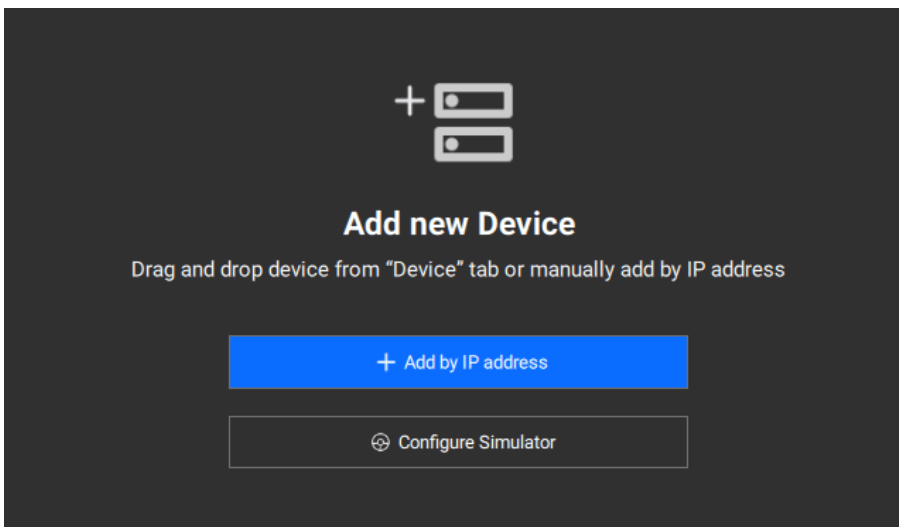

Image 7-21

4. Enter the IP address into the input field and click *Connect*.

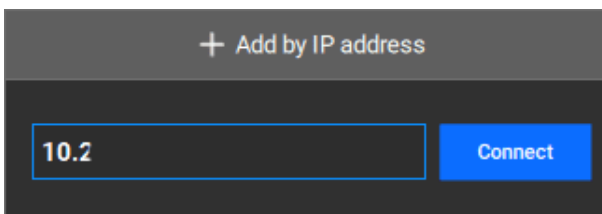



Image 7-22

Connection with the unit will be established.

5. Is this unit part of a linked system?
 - ▶ If **yes**, add additional unit(s) to the system and go to next step. For more information, see [“Linked units”](#), page 92.
 - ▶ If **no**, wait until the central work window has been populated with the added unit and go to next step.
6. Rename the system by double clicking on the current name in the top panel.

-  **Tip:** Provide clear names that reflect the intended purpose.

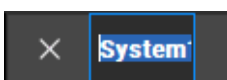

Image 7-23

7.8.2 Linked units

Location

1. **Navigation side bar:** *Configuration*
2. **Central work window:** *Detail View* or *System View*

About linked units

Event Master Toolset will detect when a link card is physically connected to another unit. A dummy outline of a unit will be created below the connected unit in the central work area. When the physical connections are made, then the software can detect the IP address of the linked unit.

If the unit will be used without the linked unit, then the dummy outline can be ignored.

Host and client

Event Master Toolset expects the host to have the unit ID set to '0'. The unit ID of the client must be different than the host. It is not possible to change the unit ID of any unit after the linked system has been created. A unit must be removed and added back to change the unit ID.

Removing a unit

Removing a unit from the link will cause the remaining unit to become a stand-alone host. This allows for another unit to be swapped in or to change the client - host relationship of the units.

Click on the x at the top of the desired unit to remove it.

Synchronizing the linked units

Synchronizing units will refresh the client unit(s). Any modifications to the outputs or card layout will be refreshed and visible in Event Master Toolset after refreshing.

Click the reset icon () at the top of the host unit to synchronize the client.

Prerequisites

One of the units, preferably the host, must be added to the central work window and the units must be physically linked with link cables. For more information, see:

- ["System creation", page 90.](#)
- ["Linking two Encore3s", page 39.](#)

How to create

1. Enter the unit ID of the unit by clicking the edit icon () after *UNIT ID*:



Image 7-24

2. Must the unit be added as a host or a client?
 - ▶ If **host**, click the *Add as Host* button.
 - ▶ If **client**, click the *Add as Client* button.



Tip: This can not be changed while the units are linked in Event Master Toolset.

Add as Host

Image 7-25

Add as Client

Image 7-26

The configuration will be created and the units will be synced to each other. This may take several minutes.

7.8.3 Disconnect a system

Location

Navigation side bar: *Configuration*

About disconnecting

Disconnecting from a system in Event Master Toolset will remove it from the multi-system list. The unit(s) will remain as a system. To remove a unit from a system, see [“Linked units”, page 92](#).

How to disconnect

1. Click on the x in front of the desired system in the top panel.

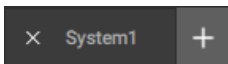

Image 7-27

A confirmation pop-up will be shown.

2. Click *Ok* to disconnect.

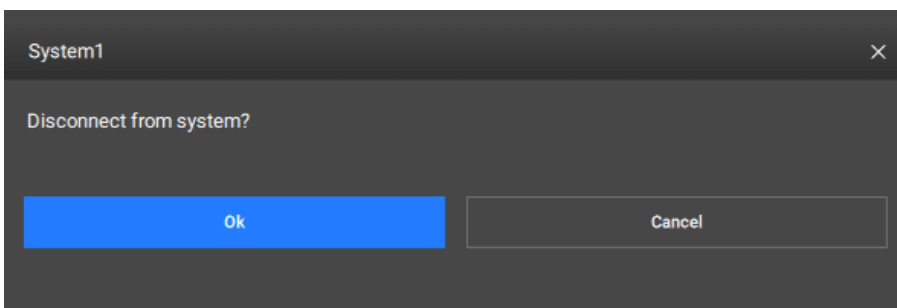

Image 7-28

7.8.4 Managing unit(s)

About managing unit(s)

Basic settings, configurations or features built into the unit can be adjusted from Event Master Toolset. Some of these settings are shared with the front panel or the web page of the unit. Where the setting is adjusted, is up to the preference of the end user.

7.8.4.1 System settings

Location

1. **Navigation side bar:** *Configuration*
2. **Central work window:** *Detail View* or *System View* or *Link Resources*
3. **Bottom panel:** If the bottom panel is hidden, click the burger menu (.

System native rate

The system native rate determines at what clock pulse, in Hz, the unit(s) run. It is advised to set the native rate of all devices to the same Hz. This ensures minimum frames or gaps are present when communicating or dealing with signals. Therefore, the genlock out signal is also tied to the system native rate.



Genlock can only be locked to external when the referenced rate is half, the same or double the system native rate.

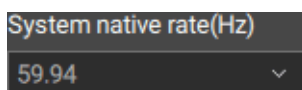



Image 7-29

If changes were made, click the save icon () in the header.

Preset conflict

Recalling presets can lead to conflicts between content that is currently in program with the content that is being loaded in preview. If program is locked, then *preset conflict mode* will decide how those conflicts are resolved:

- *Force Recall*, forces the conflicted content in program to match the content that is being recalled to preview.
- *Auto*, conflicted content will be removed from program and preset is recalled to preview. (**default**)
- *User Confirm*, a pop-up alerts the user about the conflict and lets the user manually decide how the conflict must be resolved.
- *Off*, an error message will show and the preset recall will be cancelled.



Preset conflict time (frames) will decide the maximum amount of frames that can be spent to execute the chosen conflict resolution.

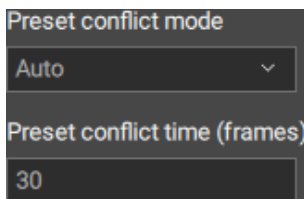



Image 7–30

If changes were made, click the save icon () in the header.

Auto save

When turned on, the unit(s) will automatically save any changes to memory after **one minute** of being idle.



If changes were made, click the save icon () in the header.



Image 7–31

7.8.4.2 Genlock

Location

1. **Navigation side bar:** *Configuration*
2. **Central work window:** *Detail View* or *System View* or *Link Resources*
3. **Bottom panel:** If the bottom panel is hidden, click the burger menu ()



genlock

Genlock syncs the first frame of each output and locks the frames to the same clock speed. This ensures that all signals are updated together.

Genlock out

The genlock out signal is always tied to the system native rate of the system. Different system native rates are valid depending on the chosen reference output resolution:

- For **SD**, 50Hz, 59.94Hz or 60Hz system native rate is valid.
- For **1080i**, 50Hz, 59.94Hz or 60Hz system native rate is valid.
- For **1080p**, all system native rates are valid.

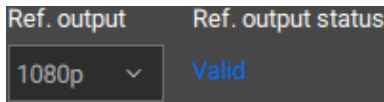

Image 7-32

A valid genlock out signal is always actively being sent on the out port, regardless of connections.

About freerun

When *Freerun* is selected from the drop down after *Genlock*, then any incoming genlock signal will be ignored by the system.



Image 7-33

How to lock to external

1. Is the system native rate half, the same or double that of the incoming signal?
 - ▶ If **yes**, go to next step.
 - ▶ If **no**, select the desired genlock rate from the drop down after *System native rate(Hz)* and go to next step.

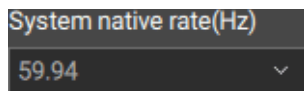

Image 7-34

2. Select *Lock to External* from the drop down after *Genlock*.



Image 7-35

The text after *Genlock status* will change to 'locked'.

3. Is an offset needed?
 - ▶ If **no**, go to next step.
 - ▶ If **yes**, adjust the offset using one of the following methods:

There are multiple ways to change the offset:

- **Using the slider:** drag the white ball over the slider until the desired amount is reached.
- **Entering a value:** enter any desired value between -100 and 100 in the input field.
- **Using the + and - buttons:** click on the + to **increase** the value with one point and on the - to **decrease** the value with one point.

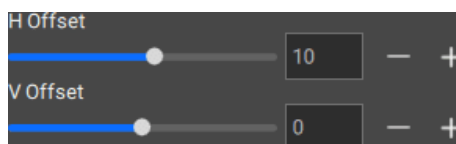

Image 7-36

4. Click the save icon (📁) in the header.

7.8.4.3 Unit information

Location

1. **Navigation side bar:** *Configuration*
2. **Central work window:** *Detail View* or *System View*
3. **Right panel:** *Adjust unit*

About unit information

Unit information shows details about the unit selected in the central work area. Changing the selection to another unit will update the information in the right panel.

It is recommended to rename each unit with a clear name. For more information on how to rename, see the following procedure.

How to rename

1. Is there more than one unit in the system?
 - ▶ If **no**, go to next step.
 - ▶ If **yes**, click on the top area of the desired unit in the central work window and go to next step.



Image 7-37

The top area of the unit will turn blue and the unit information will be changed to the selected unit.

2. Enter a desired name in the input field after *Name*.



Image 7-38

3. Click the save icon () in the header.

7.8.4.4 Reset unit

Location

1. **Navigation side bar:** *Configuration*
2. **Central work window:** *Detail View* or *System View*
3. **Right panel:** *Adjust unit*

About reset

There are four types of resets available:

- *Soft*, reboots the unit.
- *Factory*, returns all settings to their factory default value.
- *Factory and Keep*, returns settings to their factory default value. The selected settings will remain unchanged.
- *ShutDown*, puts the unit in standby mode. The power usage of the unit will decrease to 13.5W and the power button LED will turn solid red.

How to reset

1. Is there more than one unit in the system?
 - ▶ If **no**, go to next step.
 - ▶ If **yes**, click on the top area of the desired unit in the central work window and go to next step.



Image 7-39

The top area of the unit will turn blue and the unit information will be changed to the selected unit.

2. Select the desired reset method from the drop down after *Reset* in the right panel.



Image 7-40

3. Is *Factory and Keep* selected?
 - ▶ If **yes**, check all settings that must be kept. and go to next step.

▶ If **no**, go to next step.

4. Click Apply to confirm.



Tip: If any modification to the IP address was made, then remote access to the unit will be lost after the reset.

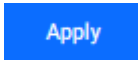

Image 7–41

7.8.4.5 Temperature

Location and unit selection

1. **Navigation side bar:** *Configuration*
2. **Central work window:** *Detail View* or *System View*
3. Click on the top area of the desired unit in the central work window.



Image 7–42

4. **Right panel:** *Adjust unit*

About temperature

The temperature category reads out the temperature and fan sensors of the selected unit.

Temperature diagnostics

A general thermal indicator () is shown after the category name. This indicator can have the following states:

- **Green:** all temperature diagnostics are *OK* or *N/A* (no problem found).
- **Red:** one temperature diagnostic is *NOK* (thermal issue on one or more components).

If there is a red icon take one of the following actions depending on where the problem is detected:

- For any **Event Master card**, replace the affected card. For more information, see “[Removing an Event Master card](#)”, page 35.
- For the **motherboard (MBoard)**, contact Barco customer service support for further assistance. For more information, see <https://www.barco.com/en/support>.
- For both **Event Master card** and **motherboard (MBoard)**, contact Barco customer service support for further assistance. For more information, see <https://www.barco.com/en/support>.

Name	Temp.	Fan
MBoard	Ok	Ok
Slot 1 - High Speed Link	Ok	N/A
Slot 2 - HDMI 2.0 Input	Ok	Ok
Slot 3 - HDMI 2.0 Input	Ok	Ok
Slot 4 - DP 1.2 Input	Ok	Ok
Slot 5 - TriCombo Input	Ok	Ok
Slot 6 - TriCombo Output	Ok	Ok
Slot 7 - HDMI 2.0 Output	Ok	Ok

Image 7–43

7.8.4.6 Setup

Location and unit selection

1. **Navigation side bar:** *Configuration*
2. **Central work window:** *Detail View* or *System View*
3. Click on the top area of the desired unit in the central work window.



Image 7-44

4. **Right panel:** *Adjust unit*

Lock/unlock the front panel

The front panel can be locked to prevent accidental touches or unwanted modifications to the Encore3.

Lock or unlock the front panel by clicking the slider after *Lock Front Panel*.



Image 7-45

If changes were made, click the save icon () in the header.

Unit ID

The unit ID is used during linking and allows the software to differentiate each Encore3 with a designated number. This number can either be a '0' or a '1'. It is recommended to assign '0' to the host unit.

Enter a desired ID ('0' or '1') in the input field after *Unit ID [0 - 1]*. If two units are linked, see ["Linked units", page 92](#) for more information.

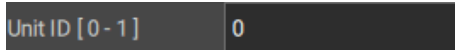



Image 7-46

If changes were made, click the save icon () in the header.

Flash front panel

Flash front panel will gradually increase and then decrease the brightness of the front panel. This changing brightness can assist in locating a desired Encore3.

Toggle the flashing behavior by clicking the slider after *Flash Front Panel*.



Image 7-47

If changes were made, click the save icon () in the header.

Front panel brightness

There are multiple ways to change the brightness:

- **Using the slider:** drag the white ball over the slider until the desired amount is reached.
- **Entering a value:** enter any desired value between 10 and 100 in the input field.
- **Using the + and - buttons:** click on the + to **increase** the value with one point and on the - to **decrease** the value with one point.

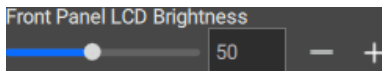



Image 7-48

If changes were made, click the save icon () in the header.

Invalid video behavior

Invalid video signals can create glitching or low quality images. These signals can be replaced with a solid black signal, thus preventing technical difficulties to be visible on screens during events.

Toggle whether the invalid signal must be shown or not by clicking the slider after *Black on Invalid Video*.

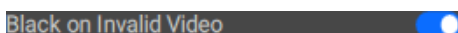



Image 7-49

If changes were made, click the save icon () in the header.

7.8.4.7 TCI mode

Location and unit selection

1. **Navigation side bar:** *Configuration*
2. **Central work window:** *Detail View* or *System View*
3. Click on the top area of the desired unit in the central work window.



Image 7-50

4. **Right panel:** *Adjust unit*

About TCI mode

Tri-combo input cards have six possible connectors. Due to limited card resources, only four of these input connectors can be active at a time. It is possible to select which group of connectors are active, by using TCI mode.

TCI mode has three different options:



The disabled connectors will not lose their configuration in the software. Any signal that is sent to them will not be processed. To reactivate the connector, change the TCI mode and the same configuration will be active again.



Each TCI card can have its own mode independent of the other cards.

- **Top 4**, disables the bottom two connectors.
- **Middle 4**, disables the top and bottom connectors.
- **Bottom 4**, disables the top two connectors.

Select the desired TCI mode from the drop down after the desired *TCI Mode Slot #*.



Image 7-51

If changes were made, click the save icon () in the header.

7.8.4.8 Time setting

Location and unit selection

1. **Navigation side bar:** *Configuration*
2. **Central work window:** *Detail View* or *System View*
3. Click on the top bar of the desired unit in the central work window.



Image 7-52

4. **Right panel:** *Adjust unit*

About time setting

The internal time of the unit can either be set manually or synced to a local or network NTP time server. Fill out the time information in the right panel.

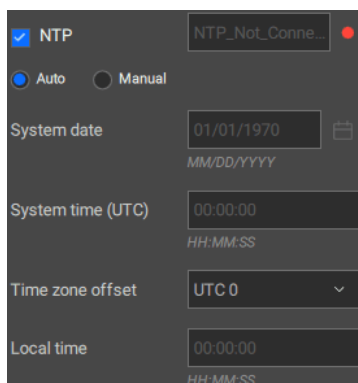

Image 7-53

To verify if the entered time information is correct, click the refresh icon (🔄) after the category name *Time Settings*.

7.8.5 Managing destinations

About managing destinations

The following chapters will explain how to create, edit or remove destination configurations for output connectors.

User assisted workflow

All available resources will be used to create the maximum number of screen destinations possible. These will fill the output cards from left to right. Any of these default connections can be removed or modified as desired.

Screen resource indicator

Event Master Toolset will keep track of how many screen destination resources are available per unit. Each possible screen destination is a section within the screen resource indicator. Sections colored in green are in use and clear sections are available screen resources.

No additional screen destinations can be added if the meter is full. Remove or edit some screen destinations to free up resources. For more information about resources, see [“Resources”, page 25](#).



Image 7-54

7.8.5.1 Deleting destinations

Location

1. **Navigation side bar:** *Configuration*
2. **Central work window:** *Detail View*
3. **Right panel:** *Output > Screen or Auxiliary*

How to delete

1. Select the desired destination(s) using one of the following methods:
 - ▶ Click on the desired output connector(s) in the card layout.
 - ▶ Click on the desired destination(s) in the mapped section next to the unit(s).
 - ▶ Select the desired output(s) from the right panel under *Screen* or *Auxiliary*.

Tip: Clicking a connector selects that connector, clicking the connector a second time deselects it.

Tip: Hold **CTRL** or **⌘** to select multiple entries at once. If this does not work, enable the keyboard shortcuts in the settings. For more information, see [“Event Master Toolset options”, page 156](#).

Tip: Selections from one method are automatically reflected in the other methods as well.



Image 7-55

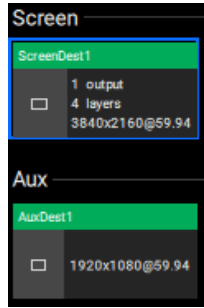

Image 7-56

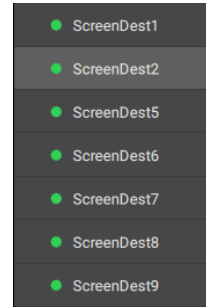

Image 7-57

2. Click *Delete Screen Destination* or *Delete Aux Destination* at the bottom of the right panel.

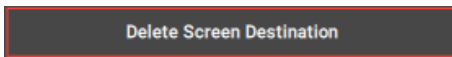

Image 7-58



Image 7-59

Confirmation is requested.

3. Verify the correct output(s) were selected and click *Delete*.

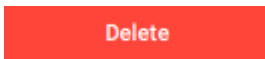

Image 7-60

The selected destinations will be removed and their resources made available.

4. Click the save icon (📁) in the header.

7.8.5.2 Creating destinations

Location

1. **Navigation side bar:** *Configuration*
2. **Central work window:** *Detail View*
3. **Right panel:** *Output > Screen or Auxiliary*

How to create

1. What destination must be added?
 - ▶ For **screen destination**, select *Screen* in the right panel.
 - ▶ For **aux destination**, select *Auxiliary* in the right panel.

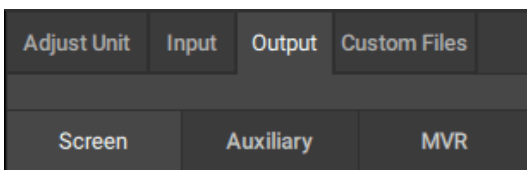

Image 7-61

2. Fill out the information about the screen in the *New* section of the chosen destination.



- 👉 *Tip:* Event Master Toolset will automatically calculate how many output connections are needed to support the entered resolution.
- 👉 *Tip:* In case of a projection screen destination, the required blend area will be calculated depending on the entered resolution .
- 👉 *Tip:* Provide clear names that reflect the intended purpose.

Output field(s) will be created in the *Outputs* section.

3. Assign a connector to the generated output field using one of the following methods:

- ▶ Click on the output field , then click on the desired connector in the central work area.
- ▶ Drag the desired output connector from the central work onto the output field in the right panel.

 *Note:* Each created field must have a connector assigned.

 *Note:* Clicking on the + icon () to add output(s) will also increase the total resolution. Clicking the trash icon () to remove output(s) will also decrease the total resolution.

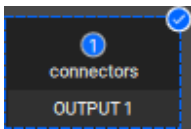

Image 7-62



Image 7-63

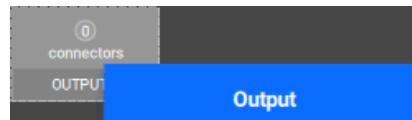

Image 7-64

The name of the connector will be added below the output field.

4. Are there more than one output fields in the *Outputs* section? (**only for screen destinations**)
 - ▶ If **yes**, repeat previous step until all outputs have a connector and go to next step.
 - ▶ If **no**, go to next step.
5. Click *Create Screen Destination* or *Create Aux Destination* to configure the outputs.

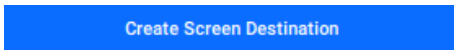

Image 7-65



Image 7-66

The selected connectors will turn green, the available resources will update, the destination will show up in the mapped overview and the name will be added to the list at the bottom of the right panel.

6. Click the save icon () in the header.

7.8.5.3 Editing screen destinations

Location

1. **Navigation side bar:** *Configuration*
2. **Central work window:** *Detail View*
3. **Right panel:** *Output > Screen or Auxiliary*

How to edit

1. Select the desired destination using one of the following methods:
 - ▶ Click on the desired output connector in the card layout.
 - ▶ Click on the desired destination in the mapped section next to the unit(s).
 - ▶ Select the desired output from the right panel under *Screen* or *Auxiliary*.

 *Note:* Only one option can be selected at a time.

 *Tip:* Selections from one method are automatically reflected in the other methods as well.



Image 7-67

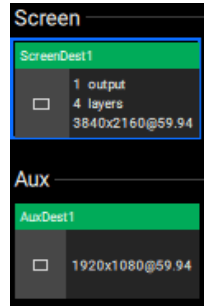

Image 7-68

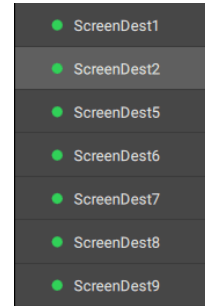

Image 7-69

A detail window will pop-up in the central work area.

2. Edit any desired settings in the pop-up window.



Note: Some settings require advanced knowledge. Ensure enough training and understanding of the setting before editing.



Tip: This pop-up window can be moved anywhere within the central work area.



Tip: If there are enough screen destination resources available, then the amount of mix layers can be increased. For more information, see [“Resources”, page 25](#).

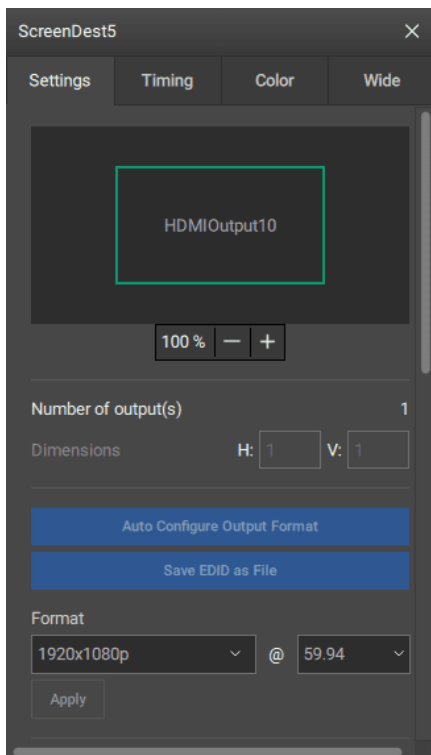

Image 7-70

3. Click the save icon () in the header.

7.8.6 Managing inputs

About managing inputs

The following chapters will explain how to create, edit or remove input configurations.

User assisted workflow

Input connectors that receive a signal will automatically create a single input in the software. This single input will adopt the configuration of the incoming signal. If the signal does not transmit a configuration or if a wrong signal is connected to the connector, then the input signal can be corrupted or look differently than expected. To prevent these issues, a connector can be configured to only accept a predefined signal.

Grouped inputs

Connectors of the same type that need to share the same configuration can be grouped. This reduces the amount of repetitive work that must be done to change the configuration of a large number of connectors.

7.8.6.1 Creating inputs

Location

1. **Navigation side bar:** *Configuration*
2. **Central work window:** *Detail View*
3. **Right panel:** *Input*

How to create

1. Must all available inputs be created?
 - ▶ If **no**, go to next step.
 - ▶ If **yes**, click *Add Multiple* and go to step 4.

Add Multiple

Image 7-71

The created inputs will be added in the input list categorised under connector type.

2. Select the desired input(s) in the card layout.



Tip: Clicking a connector selects that connector, clicking the connector a second time deselects it.

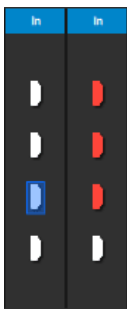

Image 7-72

3. Which of the following selections was made?
 - ▶ In case of **one** connector, click *Add Single* or *Add Multiple*.
 - ▶ In case of **multiple** connectors of the **same** type that must be **grouped**, click *Add Single*.
 - ▶ In case of **multiple** connectors of the **same** type that must be **separate**, click *Add Multiple*.
 - ▶ In case of **multiple** connectors of a **different** type, click *Add Multiple*.

Add Single

Image 7-73

Add Multiple

Image 7-74

The created inputs will be added in the input list categorised under connector type.

4. Click the save icon () in the header.

7.8.6.2 Deleting inputs

Location



1. **Navigation side bar:** *Configuration*
2. **Central work window:** *Detail View*
3. **Right panel:** *Input*

How to delete

1. Select the desired input(s) using one of the following methods:
 - ▶ Click on the desired input connector in the card layout.
 - ▶ Select the desired input(s) or group(s) from the right panel.

 *Tip:* Clicking a connector selects that connector, clicking the connector a second time deselects it.

 *Tip:* Hold **CTRL** or **⌘** to select multiple entries at once. If this does not work, enable the keyboard shortcuts in the settings. For more information, see “[Event Master Toolset options](#)”, page 156.

 *Tip:* Collapse all categories and groups in the panel by clicking on the collapse icon ().
Expand all categories and groups in the panel by clicking on the expand icon (.

 *Tip:* Selections from one method are automatically reflected in the other methods as well.

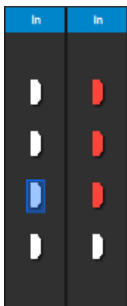

Image 7-75

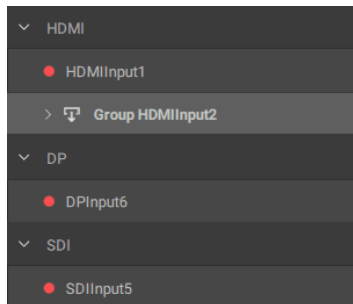

Image 7-76

2. Click *Delete* at the bottom of the right panel.

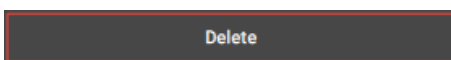

Image 7-77

Confirmation is requested.

3. Verify the correct output(s) were selected and click *Delete*.

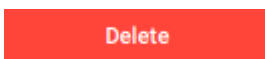

Image 7-78

The selected inputs will be removed and their connectors made available.

4. Click the save icon () in the header.

7.8.6.3 Editing inputs

Location

1. **Navigation side bar:** *Configuration*
2. **Central work window:** *Detail View*
3. **Right panel:** *Input*

How to edit

1. Select the desired input using one of the following methods:

- ▶ Click on the desired input connector in the card layout.
- ▶ Select the desired input or group from the right panel.

 *Note:* Only one option can be selected at a time.

 *Tip:* Selections from one method are automatically reflected in the other methods as well.

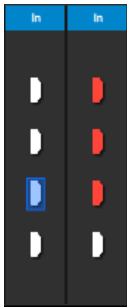

Image 7-79

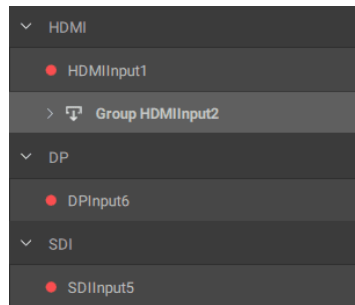



Image 7-80

A detail window will pop-up in the central work area.

2. Edit any desired settings in the pop-up window.

 *Note:* Some settings require advanced knowledge. Ensure enough training and understanding of the setting before editing.

 *Tip:* This pop-up window can be moved anywhere within the central work area.

 *Tip:* Provide clear names that reflect the intended purpose.

 *Tip:* If these custom HDR metadata or formats will be needed in the future, then it is possible to save them using the custom files feature. For more information, see [“Custom files”](#), page 109.

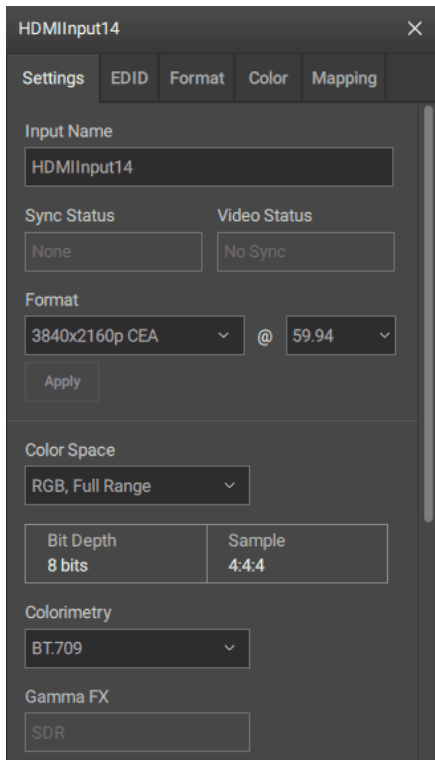

Image 7-81

3. Click the save icon () in the header.

7.8.7 MVR configuration

Location

1. **Navigation side bar:** *Configuration*
2. **Central work window:** *Detail View*
3. **Right panel:** *Output > MVR*

About MVR

MVRs are automatically created by the unit. These MVRs cannot be deleted. It is also not possible to create additional MVRs.

When an MVR is assigned directly to an output, then the entire MVR layout is streamed on that output without the need for additional configurations. For more information on how to manage the MVR layouts, see [“MVR”, page 112](#).

How to configure

1. Select the desired MVR using one of the following methods:
 - ▶ Click on the desired destination in the mapped section next to the unit(s).
 - ▶ Click on the name of the desired MVR in the right panel.

 *Note:* Only one option can be selected at a time.

 *Note:* If more than one unit is part of the system, then the MVRs in the right panel will be separated alongside unit IDs. To switch between units, click the radio button before the unit ID number.

 *Tip:* Selections from one method are automatically reflected in the other methods as well.



Image 7–82

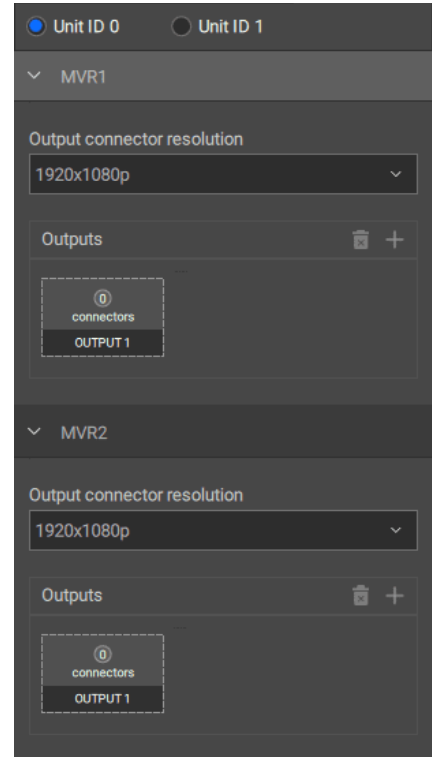

Image 7–83

A detail window will pop-up in the central work area.

2. Select the desired resolution from the drop down under *Output connector resolution* in the right panel.

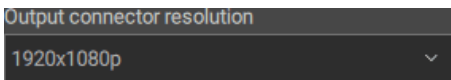

Image 7–84

3. Click on the output field in the *Outputs* section to assign the MVR to the output.

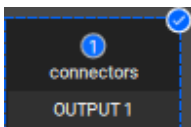

Image 7–85

4. Click on the desired connector to map the output.



 *Note:* Only output connectors from the same unit can be selected.



Image 7–86

The name of the connector will be added below the output field.

5. Edit any desired settings in the pop-up window.

-  **Note:** Some settings require advanced knowledge. Ensure enough training and understanding of the setting before editing.
-  **Tip:** This pop-up window can be moved anywhere within the central work area.

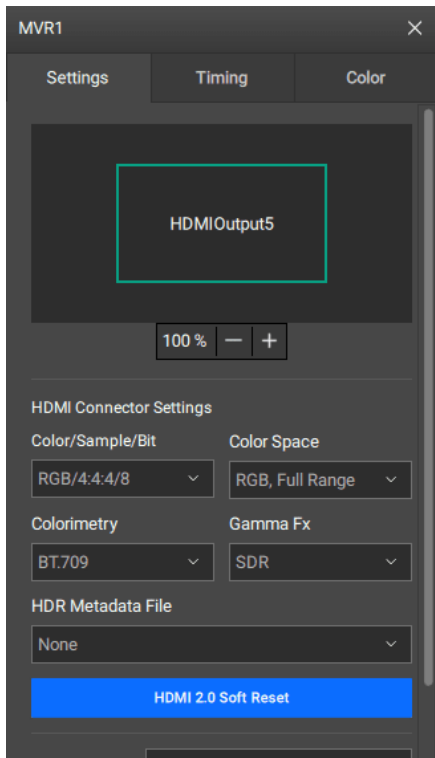



Image 7–87

6. Double click on the name in the right panel to rename the MVR.

-  **Tip:** Provide clear names that reflect the intended purpose.

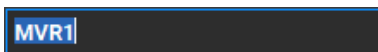

Image 7–88

7. Click the save icon () in the header.

7.8.8 Custom files

Location

1. **Navigation side bar:** *Configuration*
2. **Central work window:** *Detail View*
3. **Right panel:** *Custom Files*

About custom files

Some events need input and destination configurations that are not industry standard. These configurations can be saved as sharable custom files. There are three types of custom files:

- Formats (input and destination)
- HDR metadata (input)
- EDID (destination)

Each of these files can be used to simplify modifying inputs or destinations that must have the same custom

configuration. These files are stored in the memory of the unit and can be shared using a ShowFile. For more information, see:

- For the **front panel**, “Backup”, page 58.
- For the **web page**, “Backup”, page 71.
- For **Event Master Toolset**, “Backup”, page 149.

How to create HDR metadata and EDID files

These files can be created by editing inputs (for HDR metadata) and by editing destinations (EDID). For more information, see “Editing inputs”, page 105 and “Editing screen destinations”, page 102.



If the list is hidden, then click the arrow (➤).

How to create custom formats

1. Must a new format file be created?

- ▶ If **yes**, click on the + (+) after *Formats*.
- ▶ If **no**, go to next step.

2. Click on the desired format in the list.



Tip: If the list is hidden, then click the arrow (➤).

A pop-up will be shown in the central work area.

3. Edit the settings using the pop-up.



Tip: This pop-up window can be moved anywhere within the central work area.

4. Double click the name to rename the custom format.



Tip: Provide clear names that reflect the intended purpose.

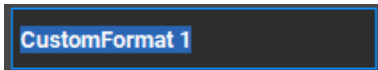

Image 7–89

5. Click the save icon (💾) in the header.

7.8.9 System view

Location

1. **Navigation side bar:** *Configuration*
2. **Central work window:** *System View*

About system view

System view will visualise how the physical link connection must be made between two Encore3s. It also highlights which unit is the host and which one is the client. For more information, see “Linking two Encore3s”, page 39.

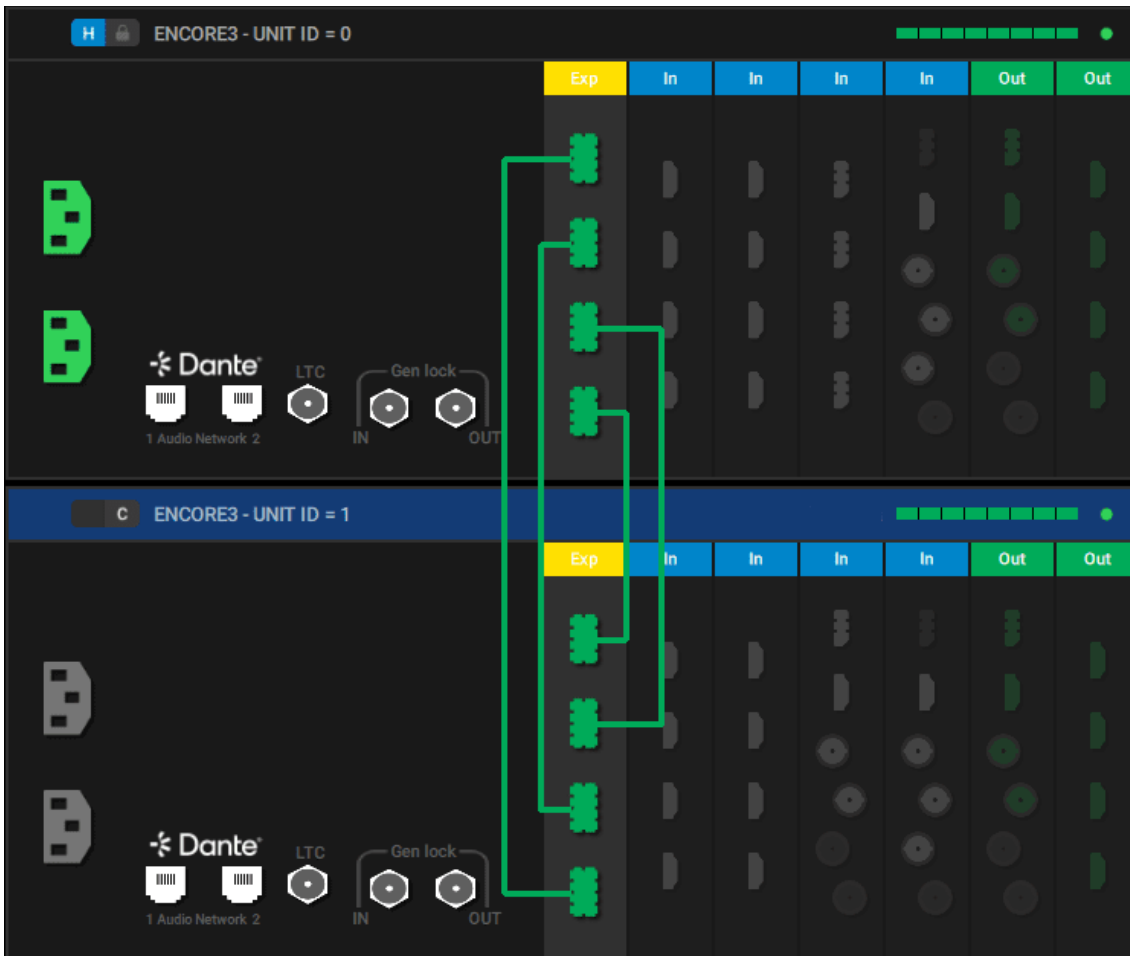

Image 7-90

7.8.10 Link resources

Location

1. **Navigation side bar:** *Configuration*
2. **Central work window:** *Link Resources*

About link resources

Link resources shows the mapping of how the bandwidth over the connecting fibres is distributed. Whenever a resource is being sent from one unit to the other, it will reserve a transmitting block (TX) and receiving block (RX) in both directions. These blocks are then reserved for this traffic alone. They will even remain locked when no transfer is happening or the resource is no longer used or active.

Advanced users can customise or release all reserved blocks. Meaning they can define which transmitter sends what resource and which receiver accepts what resource. This provides more flexibility as the user can specify only one direction and free up blocks that are reserved for things that are no longer relevant.

However, mistakes in mapping linked resources will result in unexpected behavior and images being lost. Editing is reserved for advanced users only for this reason.



Request additional training from Barco before attempting to edit linked resources.

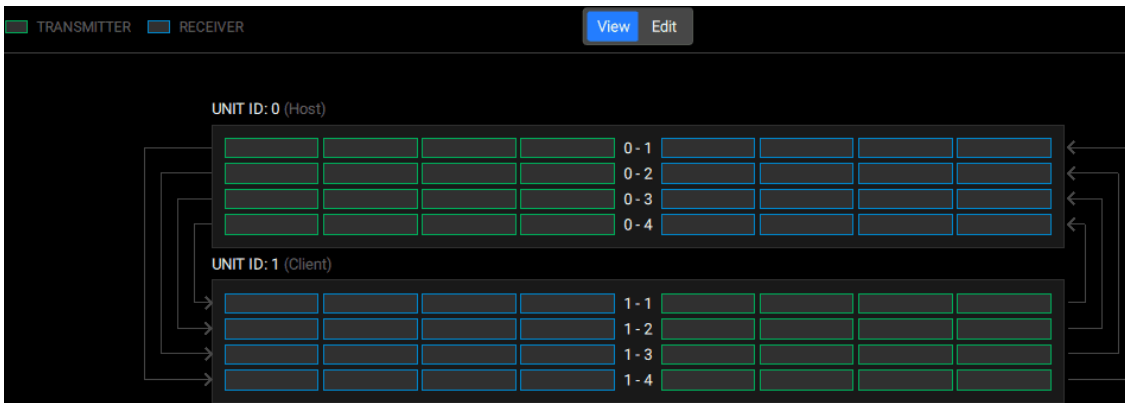



Image 7–91

7.9 MVR

About this chapter

The MVR tab () allows a user to create an overview of all inputs and screen destinations. This MVR view can then also be used as a source in the programming page. For more information, see [“Adding a source”, page 125](#). It can also be sent directly through an output with the configuration page. For more information, see [“MVR configuration”, page 107](#).

The possible MVR settings and features will be explored in the following chapters.

7.9.1 Getting started

Location

Navigation side bar: *MVR*

About the user interface

By default all available MVRs will be visible and populated with all possible destinations and inputs. Each MVR has its own tab in the top panel. This tab contains the name of the MVR and a checkbox.

View vs selection

There are two main ways of interacting with the fields in the top panel:

- Toggling the check box.
- Clicking on the field itself.

Changes will be done on all options that have the check mark in the check box () at the top panel. These changes happen independently of what is visible in the central work area. Meaning it is possible that changes are done on MVRs that are not visible currently.

What is currently visible in the central work area can be changed by clicking on the field itself. The view is independent of the check box. Meaning, options that are currently not selected can be set as the current view.

7.9.2 Editing an MVR layout



UMD

Under Monitor Display (UMD) is a user interface element for Event Master Toolset. It holds the name of the window it is attached to and a background color. The UMD is layered on top of the window and helps with identifying what that window is supposed to be. UMDs are typically only displayed within the software and not on the image. However, MVRs send the UMD with the image by default. This helps with providing context of each content window.

Location

1. **Navigation side bar:** *MVR*
2. **Left panel:** *All Sources*
3. **Right panel:** *MVR Setup* or *Adjust window* or *MVR Templates* or *MVR Presets*

Template layouts

Some MVR layout suggestions have been added as templates. These templates will create grids of windows in the shape specified by its name. These templates can be modified further or used as final layout.

How to edit

1. Select the desired MVRs at the top of the central work area.
2. Select the layout that must be edited at the top of the central work area.

 *Tip:* Each MVR can have up to 10 different layouts prepared.

 *Tip:* By default *layout1* gets auto populated depending on the configuration. If *layout1* is ever overwritten, then the auto population will no longer happen.

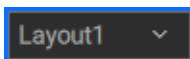



Image 7-92

3. Must a template layout be used?

 *Note:* These templates will overwrite any existing layout.

- ▶ If **yes**, select the desired grid layout from the right panel *MVR Templates* and go to next step.
- ▶ If **no**, go to next step.



4. Add windows to the central work area using one or multiple of the following methods:

- ▶ Recall a preset from the right panel *MVR Presets*. For more information, see “[MVR presets](#)”, page 114.
- ▶ Auto add all inputs with the button *Auto Layout Input* in the bottom panel.
- ▶ Auto add all destinations with the button *Auto Layout Dest* in the bottom panel.
- ▶ Drag and drop any desired source from the left panel *All Sources* to the central work panel.

 *Note:* Windows are not allowed to overlap. The UMD is not considered part of the window.

 *Tip:* If a source from the left panel is dropped on a window that already has a source, then the source will be overwritten with the dragged source from the left panel.

 *Tip:* If a window must be removed, click the *Clear* button in the bottom panel while the desired window(s) are selected.

 *Tip:* If the list is hidden, then click the arrow ().

5. Adjust the position, the size and the name of the window(s) using one or multiple of the following methods:

- ▶ Click and drag the window in the central work area to the desired position.
- ▶ Click and drag the edge of the window in the central work area to adjust the size.
- ▶ Align the selected window(s) with the icons in the bottom panel.
- ▶ Adjust the window with the *Adjust window* from the right panel.
- ▶ Enter a custom name for the window after the *UMD Text* in the *Adjust window tab* from the right panel. (optional)

 *Note:* Windows are not allowed to overlap. The UMD is not considered part of the window.

 *Tip:* Provide clear names that reflect the intended purpose.

 *Tip:* The border, AOI (Area Of Interest) marker and UMD (Under Monitor Display) label can be hidden from the MVR using the bottom panel. They will remain visible in the software.

6. Manage the background border, MVR UMD and background color in the *MVR Setup* tab of the right panel. **(optional)**

 *Tip:* The border, AOI (Area Of Interest) marker and UMD (Under Monitor Display) label can be hidden from the MVR using the bottom panel. They will remain visible in the software.



Image 7-93 Example of a possible layout with a template layout

7. Click the save icon () in the header.

7.9.3 MVR presets

Location

1. **Navigation side bar:** *MVR*
2. **Right panel:** *MVR Presets*

About MVR presets

A preset will store which layout is active on all checked MVRs and whether or not they are selected. What is in the layout is not stored in the preset. Therefore, if a layout is changed it cannot be restored with MVR presets.

Up to 10 different presets can be created.

Prerequisites

Create the desired MVR layouts for each available MVR. For more information, see [“Editing an MVR layout”, page 112](#).

How to save

1. Select the desired layout at the top of the central work area for each MVR.

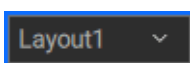



Image 7-94

2. Does a preset already exist?
 - ▶ If **no**, click on *Save* in the right panel under *MVR Presets*.

▶ If **yes** and it is **unlocked** () , click on *Overwrite* in the right panel under *MVR Presets*.

 *Tip:* Unwanted presets can be deleted by clicking the trash icon () .

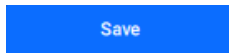

Image 7–95

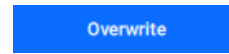



Image 7–96

3. Double click the name of the preset to rename the preset.

 *Tip:* Provide clear names that reflect the intended purpose.

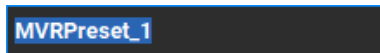



Image 7–97

4. Is it allowed to overwrite the preset in the future?

▶ If **no**, set the lock icon after the preset name to locked () .

▶ If **yes**, set the lock icon after the preset name to unlocked () .

5. Click the save icon () in the header.

7.10 Programming

About this chapter

The programming tab () is focussed on how images are displayed or prepared to be displayed. Entire shows can be controlled using the programming page.

The possible programming settings and features will be explored in the following chapters.

7.10.1 Manage layout(s)

About layout

Each destination has its own preview (PVW) and programming (PGM) field. This can fill the central work area with a lot of windows that are not always relevant to what is being done. Therefore, it is possible to create custom layouts with desired destinations. Removing destinations that are not currently relevant.

Up to 10 different layouts can be created.

7.10.1.1 Creating a layout

Location

1. **Navigation side bar:** *Programming*
2. **Bottom bar:** *Layout row*

How to create

1. Can an existing layout be used as a basis?

▶ If **yes**, duplicate an existing group by clicking the downwards arrow () after the name in the bottom panel and select *Duplicate layout*.

▶ If **no**, click the plus icon () in the *Layout row* of the bottom panel.

2. Drag and drop one desired destination from the top panel to the central work area.

 *Note:* The check box of the destination is not part of the menu that can be dragged.

 *Note:* The *View All* cannot be dragged into the central work area.

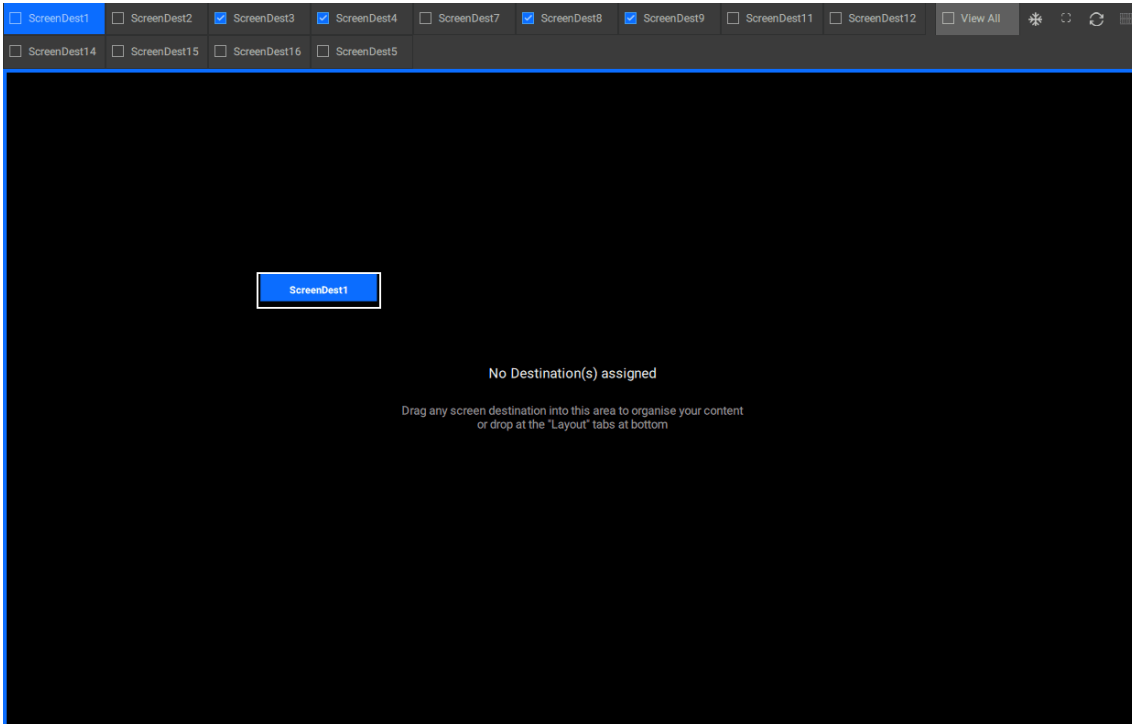





Image 7–98

3. Drag and drop the other desired destinations in the layout one by one, by using the following methods:
 - ▶ Drop the destination on the **layout entry** in the **bottom panel** to append the destination on the **right**.
 - ▶ Drop the destination on the **right side** of the **central work area** to append the destination on the **right**.
 - ▶ Drop the destination on the **left side** of the **central work area** to append the destination on the **left**.
 - ▶ Drop the destination **in between two other destinations** in the **central work area** to put it **between** them.
4. Adjust the size of each destination by clicking and dragging the line in between two destinations. (**optional**)

 *Note:* To go back to the default size, click the reset icon () in the top panel.

5. Adjust the size of each preview or program by clicking and dragging the line in between the *PROGRAM* section and the *PREVIEW* section. (**optional**)

 *Note:* To go back to the default size, click the reset icon () in the top panel.

6. Double click on the name to enter a name for the layout.

 *Tip:* Provide clear names that reflect the intended purpose.

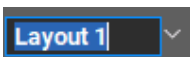

Image 7–99

7. Click the save icon () in the header.

7.10.1.2 Removing a destination from a layout

Location

1. **Navigation side bar:** *Programming*
2. **Bottom bar:** *Layout row*

How to remove

1. Click on the downwards arrow () after the layout name in the bottom panel.
2. Select *Delete destinations* from the menu.

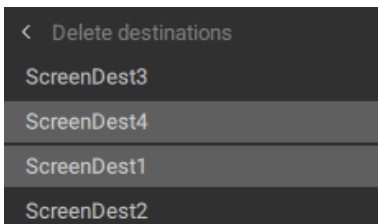

Image 7-100

3. Select the desired destination(s) from the list.



Tip: Hold **CTRL** or **⌘** to select multiple entries at once. If this does not work, enable the keyboard shortcuts in the settings. For more information, see “[Event Master Toolset options](#)”, page 156.

4. Click *Delete*.

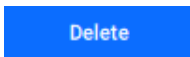

Image 7-101

The selected destinations will be removed.

5. Click the save icon () in the header.

7.10.2 Destination group

Location

1. **Navigation side bar:** *Programming*
2. **Bottom bar:** *Dest. Group* row or *Destination Group* row

About destination groups

Transitions or output freezing often affect multiple destinations at the same time in the same way. Destination groups make it possible to group these specific selections for when the actions must be applied.



How to create

1. Check () the check boxes in front of all desired destination names.



Tip: The selection is independent of the active layout in the central work area.

2. Must a new destination group be created?

- ▶ If **yes**, click the plus icon () in the *Dest. Group* or *Destination Group* row of the bottom panel.
- ▶ If **no**, overwrite an existing group by clicking the downwards arrow () after the name in the bottom panel and select *Overwrite Group*.

A new destination group will be created with the selected destinations.

3. Double click on the name to enter a name for the group.



Tip: Provide clear names that reflect the intended purpose.

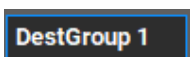

Image 7-102

4. Click the save icon () in the header.

7.10.3 Layers

About layer view

Layer view reveals a screen layer bar in between *PROGRAM* and *PREVIEW* in the central work area. This screen layer bar shows how many and which type of layers are available for the destination. For more information on layer types, see [“Resources”, page 25](#).

7.10.3.1 Mixing or splitting layers

Location

1. **Navigation side bar:** *Programming*
2. **Central work area:** *Screen layer bar*

Prerequisites

The screen layer bar is only visible when three or less destinations are being viewed in the central work area.

How to mix or split

1. Is the screen layer bar visible in the middle of the central work area?
 - ▶ If **no**, toggle the layer view in the upper right corner of the central work area and go to next step.
 - ▶ If **yes**, go to next step.

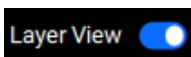

Image 7-103

2. Select either the 'A' or 'B' section of the desired layer(s) in the screen layer bar.



Tip: Hold **CTRL** or **⌘** to select multiple entries at once. If this does not work, enable the keyboard shortcuts in the settings. For more information, see [“Event Master Toolset options”, page 156](#).

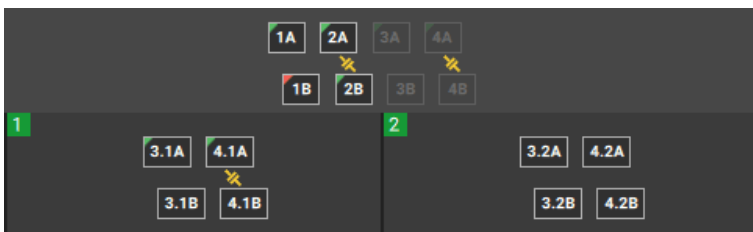

Image 7-104 Example of a wide screen destination with split, mix and output layers

3. Are the layers mixed or split?
 - ▶ If **mixed**, click *Split* in the bottom panel to separate the 'A' and 'B' layer.
 - ▶ If **split**, click *UnSplit* in the bottom panel to merge the 'A' and 'B' layer.



Note: It is not possible to mix layers with a different number. Meaning, layer '1A' can only be mixed with '1B' and no other layer.



Tip: Split layers have the split icon (⚡) between the 'A' and 'B' layer.



Tip: If the selection contains multiple layers in a different state, then the first selected layer will dictate the available behavior.

Split

Image 7-105

UnSplit

Image 7-106

4. Click the save icon (💾) in the header.

7.10.3.2 Screen and output layers

Location

1. **Navigation side bar:** *Programming*
2. **Central work area:** *Screen layer bar*

Prerequisites

Only the wide screen destination is visible in the central work area.

How to merge or unmerge

1. Is the screen layer bar visible in the middle of the central work area?
 - ▶ If **no**, toggle the layer view in the upper right corner of the central work area and go to next step.
 - ▶ If **yes**, go to next step.

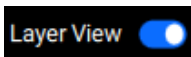



Image 7-107

2. Are the layers output layers or screen layers?
 - ▶ For **screen layer**, select either the 'A' or 'B' section of the desired layer(s) in the top row of the screen layer bar.
 - ▶ For **output layer**, select **all** 'A' or 'B' sections with the same leading number from each output in the bottom row of the screen layer bar.

 **Note:** All output layers from each output with the same leading number and letter must be selected before they can be merged. For example, a wide screen with 3 outputs must have output layer '2.1A', '2.2A' and '2.3A' selected before they can be merged into screen layer '2A'.

 **Tip:** Hold **CTRL** or **⌘** to select multiple entries at once. If this does not work, enable the keyboard shortcuts in the settings. For more information, see "[Event Master Toolset options](#)", page 156.

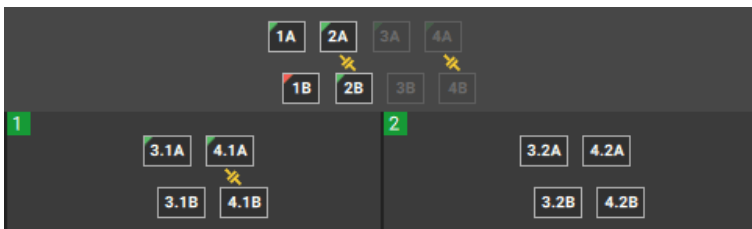



Image 7-108

3. Click *Merge* or *UnMerge* in the bottom panel.

 **Tip:** If the layers were split, then they will remain split after merging or unmerging.

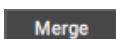

Image 7-109

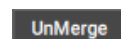

Image 7-110

4. Click the save icon () in the header.

7.10.4 Organizing lists

About organizing lists

Some lists can have a large amount of entries. Making it difficult to get an overview and time consuming to find what is needed. For this reason the following lists can be organized:

- Sources (list can only be organized in subfolders)
- Presets
- User keys

Each list follows the same general procedures to organize. The following procedure is written for source organisation, but is applicable for each type.

About folders

Folders group desired entries into one cohesive list. Removing clutter and entries that are not relevant for the current actions.

A maximum of **four** custom folders can be displayed at a time. Additional folders will be under the *Customize folder...* option of the folder menu (⋮).

How to organize

1. Is the organisation for the sources?
 - ▶ If **yes**, enable the slider in front of *Source List*.
 - ▶ If **no**, go to next step.

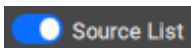

Image 7-111

2. Select the desired entries from the list.



Tip: Hold **CTRL** or ⌘ to select multiple entries at once. If this does not work, enable the keyboard shortcuts in the settings. For more information, see “[Event Master Toolset options](#)”, page 156.

3. Must the selection be added to an existing folder?

- ▶ If **yes**, click on the move icon (⇧) and select the desired folder. Go to step 5.
- ▶ If **no**, go to next step.

4. Create a new folder.

- a) Click the folder menu (⋮).
- b) select *New folder...*
- c) Enter a name for the folder in the input field after *Folder name*.



Tip: Provide clear names that reflect the intended purpose.

- d) Click *Create*.

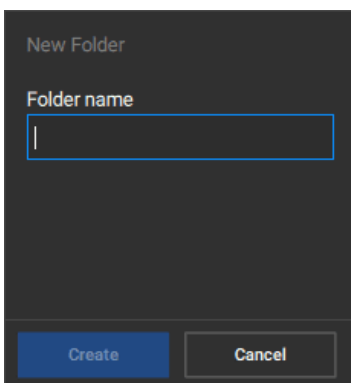

Image 7-112

If there are less than four folders visible, then the new folder gets added to the top. Else it gets added to the *Customize folder...* list.

5. Open the desired folder.

6. Click the reorder icon (⇄).



Note: Remove any selection by clicking the trash icon (🗑).

7. Drag and drop any source to its desired position in the list.

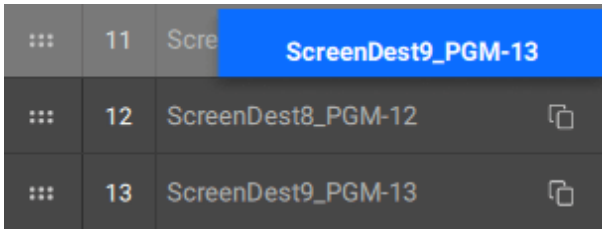

Image 7-113

8. Click the save icon () in the header.

7.10.5 Adding stills



Location

1. **Navigation side bar:** *Programming*
2. **Left panel:** *All Sources*

Prerequisites

The image must be in *.png* format to be used as a still.

How to add

1. Click the plus icon () at the bottom of the left panel.
A pop-up window will be shown.
2. Navigate to the location of the image(s) and click open.
 *Tip:* Hold **CTRL** or **⌘** to select multiple entries at once.
3. Wait until the images have been uploaded.
The image(s) will be added to the sources list under *Stills*.
4. Click the save icon () in the header.

7.10.6 Capturing stills

Location

1. **Navigation side bar:** *Programming*
2. **Left panel:** *All Sources*

About capturing

Event Master Toolset can capture a frame directly from a live input and store it as a still. The captured still will then be added as a source and stored on the video processor. For more information on how to download the still, see [“Export stills”](#), page 62.

How to capture

1. Is the slider in front of *Source List* on?
 - ▶ If **yes**, click the slider to disable *Source List* and go to next step.
 - ▶ If **no**, go to next step.

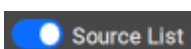



Image 7-114

2. Click the *Freeze input* icon () of the desired input to lock the frame. (**optional**)



- Click the *Capture still* icon () to capture the **current** frame as a still. The still will be added to the source list.
- Double click on the name to enter a name for the still.



Tip: Provide clear names that reflect the intended purpose.

StillStoreGroup HDMIInput1

Image 7–115

- Click the *Freeze input* icon () of the desired input to stop locking the frame. (**optional**)
- Click the save icon () in the header.

7.10.7 Source thumbnail

Location

- Navigation side bar:** *Programming*
- Left panel:** *All Sources*

About thumbnails

Thumbnails provide a visual aid on what the source displays. These thumbnails are a static snapshot of the content from the source at a random time. To update a thumbnail, click the refresh icon () of the desired source. Thumbnails are not visible outside of Event Master Toolset.

It is possible to overwrite the snapshot thumbnails to a custom image. For more information on how to set a custom thumbnail, see the following procedure.



No thumbnails will be generated when using the simulator. Custom thumbnails can help create a more realistic overview.

How to set

- Is the slider in front of *Source List* on?
 - ▶ If **yes**, click the slider to disable *Source List* and go to next step.
 - ▶ If **no**, go to next step.

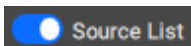







Image 7–116

- Set the view of the left panel to *Show thumbnail view* ().
 -  *Note:* Thumbnails can only be viewed in the *All Sources* tab. They are not visible in the folders.
- Click on the thumbnail location of the desired source in the left panel.
 -  *Tip:* Collapse all categories and groups in the panel by clicking on the collapse icon (). Expand all categories and groups in the panel by clicking on the expand icon (.

A pop-up window will be shown.

- Navigate to the location of the image and click open. The image will be shown in the thumbnail slot of the source and in the central work area of the source.
- Click the save icon () in the header.

7.10.8 Adding backup input

Location

1. **Navigation side bar:** *Programming*
2. **Left panel:** *All Sources*

About backup input

Inputs can lose connection or go offline during an event. When this happens, Event Master Toolset can switch the input to a backup input. This ensures that an image is restored as soon as possible. When the original input is back online, then the Event Master Toolset will show a green dot () before the name. The user can then decide whether the input must go back to the original input.

How to set

1. Is the slider in front of *Source List* on?
 - ▶ If **yes**, click the slider to disable *Source List* and go to next step.
 - ▶ If **no**, go to next step.

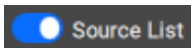









Image 7-117

2. Click on the right arrow () below the input name or thumbnail of the desired input.
3. Select a backup source from the drop down after *Backup*.

 *Note:* *Backup1* will be used first. If *Backup1* is also offline, then *Backup2* will be used. If *Backup2* is also offline then *Backup3* will be used. If *Backup3* is also offline, then there will be no image.

 *Tip:* A maximum of three backup inputs can be defined.

 *Tip:* Stills can be set as a backup input. It is recommended to have the last backup input set as a still.

 *Tip:* Active inputs will have an active icon ().
Offline inputs will have an inactive icon ().

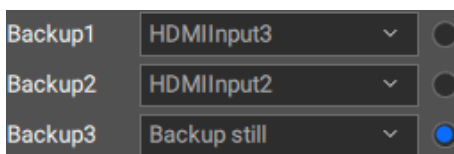

Image 7-118

4. Click on the radio button after the drop down to manually switch to the selected backup. (**optional**)
5. Click on the slider in front of *Auto Switch* to turn on the automatic backup functionality.

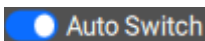

Image 7-119

The label under the thumbnail will indicate whether the *Primary* source is active or a *Backup* source is active.

6. Click the save icon () in the header.

7.10.9 Multiple sources

Location

1. **Navigation side bar:** *Programming*

2. Left panel: All Sources

About multiple sources

Multiple sources allow the user to copy the incoming signal. This copy can then be modified to apply changes to the incoming signal. Each copy can have its own sets of modifications. Making it possible to quickly switch between different modifications and the source signal. For more information on how to edit the way each source looks, see [“Editing a source”, page 131](#).

How to add

1. Is the slider in front of *Source List* on?
 - ▶ If **yes**, click the slider to disable *Source List* and go to next step.
 - ▶ If **no**, go to next step.

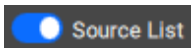

Image 7-120

2. Click the plus icon (+) of the desired source.
3. Rename the source by double clicking on the name.



Tip: If the source list is turned off, then the sources can be found by clicking on the right arrow (➤) before the thumbnail or name of the input.



Tip: Provide clear names that reflect the intended purpose.

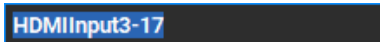

Image 7-121

4. Click on the right arrow (➤) before the thumbnail in thumbnail view or before the source name in list view. (optional)
5. Click the save icon (📁) in the header.

7.10.10 Scene creation

About scene creation

The following chapters describe how to prepare or create scenes using all the configured sources on the configured destinations. The same steps can be followed regardless of source or destination.

Preview vs program

Preview allows for scenes to be prepared without the displayed image being affected. Program is actively being displayed and changes will happen in real time.

The following chapters explain the steps for preview. The same steps can be done in program. It is recommended to avoid making changes directly in program when possible.

PIP vs key

A PIP (picture in picture) layer will position themselves according to their Z-order. Therefore, PIP layers can have borders and/or shadows to make them stand out from the mix background layer and/or other layers. For more information about Z-order, see [“Layer Z-order”, page 129](#).

A key layer can do actions on certain colors or brightness values. Based on these values the layer can have parts with those characteristics removed or replaced. Helping them blend in with the mix background layer and/or other layers. A common example of a key layer is in combination with a green screen.

7.10.10.1 Adding a layer

Location

1. **Navigation side bar:** *Programming*
2. **Central work area:** *PREVIEW* or *PROGRAM*

About creating a layer

The first time a layer is created or used, no source will be added to the layer. If a source has been added to the layer at any time, then the layer will be created with the last source automatically added. This memory is not affected by type changes.

The source of a layer can be changed by adding or overwriting the source of the layer. For more information, see [“Adding a source”, page 125](#).

How to add

1. Click on the desired destination from the top panel or desired screen destination group from the bottom panel.
2. Is the screen layer bar visible in the middle of the central work area?
 - ▶ If **no**, toggle the layer view in the upper right corner of the central work area and go to next step.
 - ▶ If **yes**, go to next step.

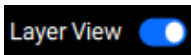

Image 7–122

3. Drag and drop the desired layer into the scene.

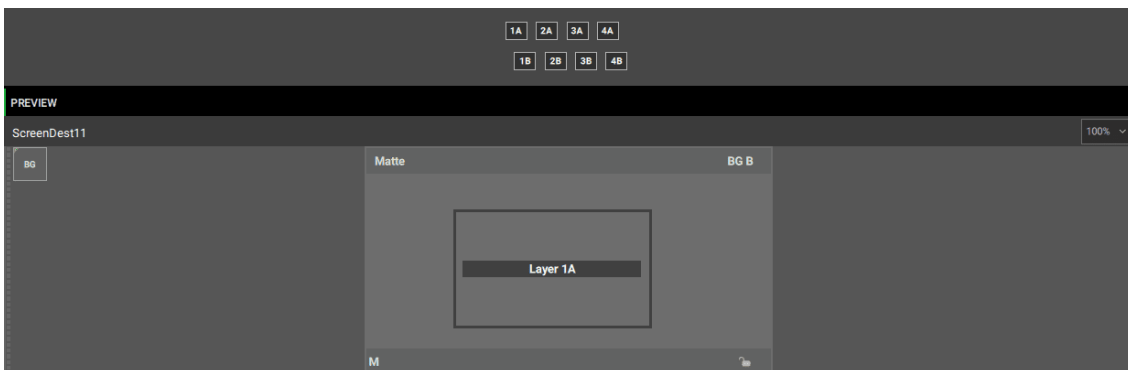

Image 7–123

A layer will be added.

4. Click the save icon () in the header.

7.10.10.2 Adding a source

Location

1. **Navigation side bar:** *Programming*
2. **Left panel:** *All Sources* or source folder
3. **Central work area:** *PREVIEW* or *PROGRAM*

About adding sources

Sources can be added to empty layers or overwrite already existing layers. If no layer is present, then Event Master Toolset will automatically use the first available layer with the source. In case of split layers, the 'B' layer comes before the 'A' layer.

Wide screen output layer prerequisites

Layers must be added from the screen layer bar before sources can be added. For more information, see [“Adding a layer”, page 125](#).

How to add

1. Click on the desired destination from the top panel or desired screen destination group from the bottom panel.
2. Is the scene or layer locked (🔒)?
 - ▶ If **yes**, click the unlock icon (🔓) in the bottom left of the scene or in the bottom panel and go to next step.
 - ▶ If **no**, go to next step.

 **Note:** If the layer is a split layer that is transitioned to program, then the layer must either be removed from program or program must be unlocked before it can be edited in preview.

3. Does the desired layer exist?
 - ▶ If **yes**, drag and drop the desired source from the left panel on the layer.
 - ▶ If **no**, drag and drop the desired source from the left panel to an empty space of the scene. (**not available for wide screens with output layers**)

 **Note:** If the source and screen destination are not from the same unit, then a link resource will be reserved.

 **Tip:** Collapse all categories and groups in the panel by clicking on the collapse icon (⌵).

Expand all categories and groups in the panel by clicking on the expand icon (⌵).

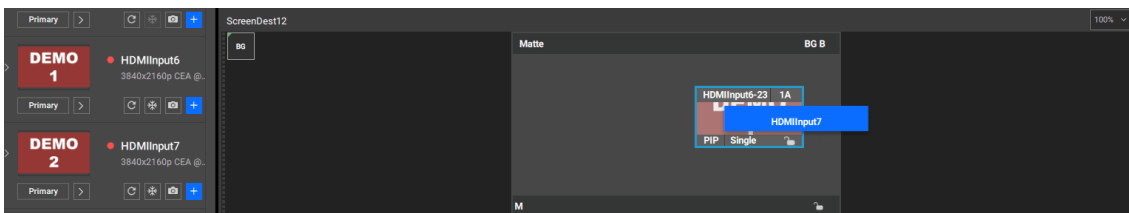

Image 7–124

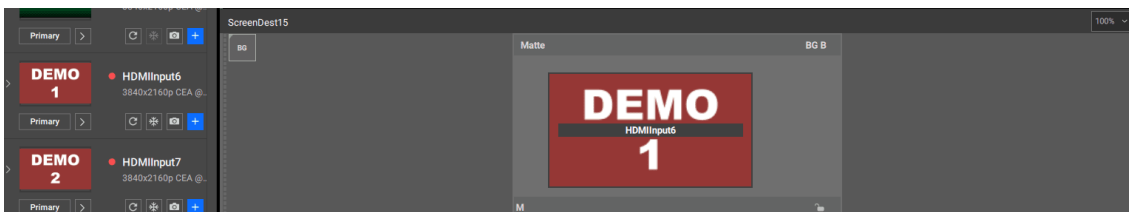

Image 7–125

The layer will get the name and thumbnail of the dropped source.

4. Click the save icon (💾) in the header.

7.10.10.3 Mix background layer



Location

1. **Navigation side bar:** *Programming*
2. **Central work area:** *PREVIEW > BG* or *PROGRAM > BG*
3. **Right panel:** *Adjust BG*

About the mix background layer

The mix background layer of a destination functions like a normal mix layer. It can have a matte color or a source applied. By default, the mix background layer is set to a matte black color.

How to edit

1. Click on the desired destination from the top panel or desired screen destination group from the bottom panel.
2. Click on the background icon () or the mix background layer.
3. Is the mix background layer in program?
 - ▶ If **yes**, click the lock icon () of *PROGRAM* to modify the mix background layer and go to next step.
 - ▶ If **no**, go to next step.
4. Must a source be applied to the mix background layer?
 - ▶ If **yes**, drag and drop the desired source from the left panel on the background icon () and go to next step.
 - ▶ If **no**, go to step 6.

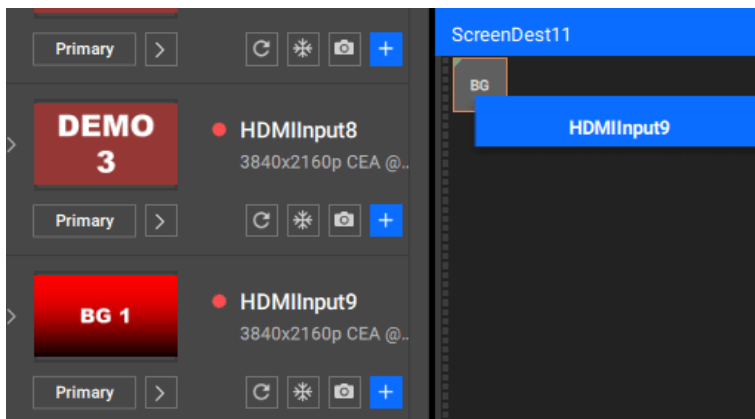



Image 7-126



5. Position the background. For more information, see [“Positioning a layer”, page 128](#). (optional)
6. Modify the background using the options from the right panel.
7. Click the save icon () in the header.

7.10.10.4 Removing a layer

Location

1. **Navigation side bar:** *Programming*
2. **Left panel:** *All Sources* or source folder
3. **Central work area:** *PREVIEW* or *PROGRAM*

How to remove

1. Click on the desired destination from the top panel or desired screen destination group from the bottom panel.
2. Select the desired layer(s) from the scene.
 -  *Tip:* Hold **CTRL** or **⌘** to select multiple entries at once. If this does not work, enable the keyboard shortcuts in the settings. For more information, see [“Event Master Toolset options”, page 156](#).
3. Is the selection locked ()?
 - ▶ If **yes**, click the unlock icon () in the bottom panel and go to next step.

► If **no**, go to next step.



Note: If the layer is a split layer that is transitioned to program, then the layer must either be removed from program or program must be unlocked before it can be edited in preview.

4. Click *Clear* in the bottom panel.

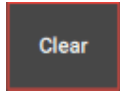



Image 7-127

The selected layer(s) will be removed from the scene.

5. Click the save icon () in the header.

7.10.10.5 Positioning a layer

Location

1. **Navigation side bar:** *Programming*
2. **Central work area:** *PREVIEW* or *PROGRAM*
3. **Right panel:** *Adjust Layer > Layer window* () or *Adjust BG*

Positioning the background source

A mix background layer with a source assigned can be moved using the same principles as the layer position. Moving the source within the mix background layer will show different parts of the image depending on the position. This can create the illusion of animation or allow for the switching of the background image without needing to change the source.

Methods to position a layer

There are three main methods to position a layer in the scene. All three methods can be used to fine tune the position of the layer within the scene.



Layers can be partially or fully outside the active area of the screen destination. The parts outside the active area will not be visible.

- Dragging and dropping the layer in the desired location within the scene.
- Modifying the layers absolute *H Position* and *V Position* with one of the following methods in the right panel:
 - **Using the slider:** drag the white ball over the slider until the desired amount is reached.
 - **Entering a value:** enter any desired value in the input field.
 - **Using the + and - buttons:** click on the + to **increase** the value with one point and on the - to **decrease** the value with one point.

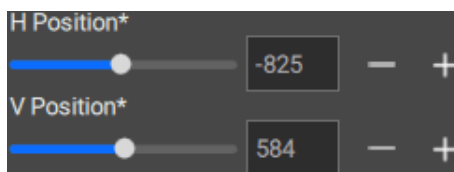





Image 7-128

- Aligning the layer to another selected layer with the bottom panel. For more information, see the following procedure.

How to align using the bottom panel

1. Click on the desired destination from the top panel or desired screen destination group from the bottom panel.
2. Is the layer locked ()?

- ▶ If **yes**, click the unlock icon () in the bottom panel and go to next step.
- ▶ If **no**, go to next step.

 **Note:** If the layer is a split layer that is transitioned to program, then the layer must either be removed from program or program must be unlocked before it can be edited in preview.

3. Select all the layers that must be aligned.

 **Tip:** Hold **CTRL** or **⌘** to select multiple entries at once. If this does not work, enable the keyboard shortcuts in the settings. For more information, see “[Event Master Toolset options](#)”, page 156.

4. Click on the desired alignments from the bottom panel.

 **Note:** Some options are only available when three or more layers are selected.

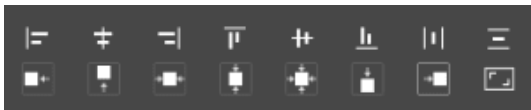

Image 7–129

5. Click the save icon () in the header.

7.10.10.6 Layer Z-order



Z-order

Z-order is an ordering method that determines whether an element appears in front or behind another element. This ordering makes it possible to position elements in a space without using additional processing power.

Location

1. **Navigation side bar:** *Programming*
2. **Central work area:** *PREVIEW* or *PROGRAM*

Z-order limitations

Z-order cannot be used for split layers nor output layers. These layers will always be arranged according to their layer number. If a layer must be behind or in front of another layer, then they must be assigned to another layer. For more information, see “[Adding a source](#)”, page 125.

How to change

1. Click on the desired destination from the top panel or desired screen destination group from the bottom panel.

2. Is the layer locked ()?

- ▶ If **yes**, click the unlock icon () in the bottom panel and go to next step.
- ▶ If **no**, go to next step.

 **Note:** If the layer is a split layer that is transitioned to program, then the layer must either be removed from program or program must be unlocked before it can be edited in preview.

3. Select the desired layer.
4. Click on the Z-order buttons from the bottom panel until the layer is in the desired Z-order position.





Image 7–130

5. Click the save icon () in the header.

7.10.10.7 Editing a layer

Location



1. **Navigation side bar:** *Programming*
2. **Central work area:** *PREVIEW* or *PROGRAM*
3. **Right panel:** *Adjust Layer > Layer settings* () or *Adjust Layer > Layer window* () or *Adjust Layer > Layer effects* () or *User Key > All User key*

About editing a layer

Event Master Toolset allows for a wide variety of modifications on a layer. These modifications do not affect the source nor other layers. Each modification is layered on top of the source to create a desired outcome.

To save time, layer edits can be saved under a user key. For more information, see “[User keys](#)”, page 133.

How to edit

1. Click on the desired destination from the top panel or desired screen destination group from the bottom panel.
2. Is the layer locked ()?
 - ▶ If **yes**, click the unlock icon () in the bottom panel and go to next step.
 - ▶ If **no**, go to next step.
3. Select all the layers that must be edited the same way.
4. Are the desired changes saved in a user key?
 - ▶ If **yes**, select the desired user key in *All User key* of the right panel and click *Apply Selected*. No further actions needed.
 - ▶ If **no**, go to next step.
5. Select the desired layer type in *Adjust Layer* of the right panel.



Note: If the layer is a split layer that is transitioned to program, then the layer must either be removed from program or program must be unlocked before it can be edited in preview.



Tip: Hold **CTRL** or **⌘** to select multiple entries at once. If this does not work, enable the keyboard shortcuts in the settings. For more information, see “[Event Master Toolset options](#)”, page 156.



Tip: Default is PIP with matte color disabled.

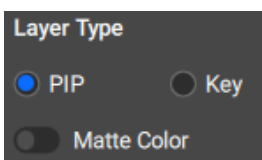





Image 7-131

6. Edit the desired parameters of the layer using one or more of the following menus:
 - ▶ Using the **layer settings** ()
 - ▶ Using the **layer window menu** ()
 - ▶ Using the **layer effects menu** ()
7. Store the changes in a user key. For more information, see “[User keys](#)”, page 133. (**optional**)



Tip: For more information on how to use *KeyFrame*, see “[Applying a move animation](#)”, page 131.

- Click the save icon () in the header.

7.10.10.8 Editing a source

Location

- Navigation side bar:** *Programming*
- Central work area:** *PREVIEW* or *PROGRAM*
- Right panel:** *Adjust source*

About editing a source





Source modifications are applied to all usages of that source in both preview and program. Locked instances will also receive the source modifications. Any layer modification is layered on top of the source modification. For more information on layer modifications, see [“Editing a layer”, page 130](#).

To save time, layer sources can be saved under a user key. For more information, see [“User keys”, page 133](#).

Prerequisites

The source must be added into a layer in the central work area before it can be edited. For more information, see [“Adding a source”, page 125](#).

How to edit

- Click on the desired destination from the top panel or desired screen destination group from the bottom panel.
- Select any layer that contains the desired source.
- Edit the source settings in the right panel.
 -  *Tip:* Clicking the refresh icon () will revert any changes back to their default value.
 -  *Tip:* Both settings and color of the source can be changed at the same time.
- Must the source edits be applied when a user key is applied?
 - ▶ If **yes**, select the desired user key from the drop down menu after *Bind to User Key* and go to next step.
 - ▶ If **no**, go to next step.
 -  *Tip:* These source edits can be bound to any user key, even if the user key is not related to the current source. When the bound user key is applied, then the source edits will also be applied to any instance of the current source across the entire system.

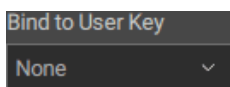

Image 7-132

- Click on *Save Source* to commit the changes.

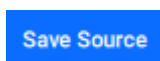

Image 7-133

- Click the save icon () in the header.

7.10.10.9 Applying a move animation

Location

- Navigation side bar:** *Programming*
- Central work area:** *PREVIEW* or *PROGRAM*
- Right panel:** *Adjust Layer > KeyFrame*

About move animations

Move animations allow motion to be played on individual layers during a transition. These movements allow a layer to move to desired positions or change size in a natural way. Animations can have part of the animation out of the active area.

How to move

1. Click on the desired destination from the top panel or desired screen destination group from the bottom panel.
2. Select the desired layer in the scene.
3. Is the selected layer locked (🔒)?
 - ▶ If **yes**, click the unlock icon (🔓) in the bottom panel and go to next step.
 - ▶ If **no**, go to next step.

 **Note:** If the layer is a split layer that is transitioned to program, then the layer must either be removed from program or program must be unlocked before it can be edited in preview.
4. Add a keyframe using one of the following methods:
 - ▶ Click the *Move* button in the bottom panel. (Only available when the layer is transitioned to program.)
 - ▶ Click *Add KF* in the right panel.

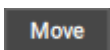

Image 7-134

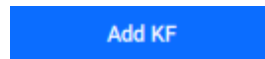

Image 7-135

An outline target keyframe is created in the scene at the same position as the layer.

5. Modify the desired number of frames the move animation must take in the right pane using one of the following methods: (**optional**)
 - ▶ **Using the slider:** drag the white ball over the slider until the desired amount is reached.
 - ▶ **Entering a value:** enter any desired value between 0 and 1999 in the input field.
 - ▶ **Using the + and - buttons:** click on the + to **increase** the value with one point and on the - to **decrease** the value with one point.

 **Tip:** By default the animation will take 30 frames.



Image 7-136

6. Position and/or change the size of the target keyframe in the scene.

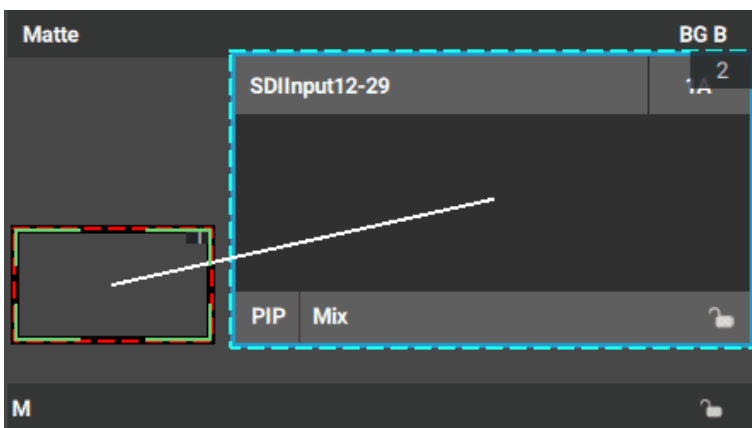

Image 7-137

7. Store the animation in a user key. For more information, see [“User keys”, page 133](#). (**optional**)
8. Click *Arm* to execute the animation with the next transition.

Arm

Image 7–138

- Transition the scene. For more information, see [“Transitioning a scene”, page 136](#).



Tip: If the layer is not in program when transitioning, then the layer will be transitioned to the start location and execute the animation in one continuous motion.

- Click the save icon () in the header.

7.10.11 User keys

Location

- Navigation side bar:** *Programming*
- Central work area:** *PREVIEW* or *PROGRAM*
- Right panel:** *User Key*

About user keys

User keys save desired changes of layers. These changes can then be applied to other layers where a similar effect or change is needed without affecting other settings of the layer.

Prerequisites

The layer must be modified with the desired changes. For more information, see the relevant topics in [“Scene creation”, page 124](#).

How to create

- Select the desired layer in the scene.
- Decide which settings must be included.
 - ▶ If **all** options must be **included**, enable the check box in front of *Enable All Type*.
 - ▶ For each option that must be **included**, check the check box in front of the settings name.
 - ▶ For each option that must be **excluded**, uncheck the check box in front of the settings name.



Tip: If the options are hidden, then click the arrow ()

- Decide how the user key must be created in *Creation Mode*. (**optional**)
 - ▶ Check the check box in front of *Rename* if the created user key will be named immediately.
 - ▶ Check the check box in front of *Lock* if the user key must be locked for editing.

Rename Lock

Image 7–139

- Must an existing user key be overwritten?
 - ▶ If **yes** and the user key is **unlocked** () , select the user key and click *Overwrite User Key*.
 - ▶ If **no**, click *Save to new User Key*.

Save to new User Key

Image 7–140

Overwrite User Key

Image 7–141

- Was the option *Rename* selected?
 - ▶ If **yes**, enter a name for the user key.
 - ▶ If **no** and the user key is **unlocked** () , double click on the name and enter a name.



Tip: Provide clear names that reflect the intended purpose.

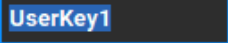

Image 7-142

6. Double click on the number in front of the user key and enter a desired number. **(optional)**



Note: Numbers must be unique.



Tip: Up to two decimal numbers are allowed.



Tip: The automatic numbering will ignore decimal numbers and add one to the highest whole number in the list.



Tip: The number decides at which position it is located in the list.



Image 7-143

7. Click the save icon () in the header.

7.10.12 Presets

About presets

Presets save the position and configurations of the layers and mix background layers from either program or preview. These scenes can be recalled from the preset at a later time to preview.

About global presets

Global presets are presets that can be accessed by other Event Master devices. These presets will be visible when adding the current system as an external device. Alternatively, global presets from other Event Master devices that have been added, can also be used on the current system. For more information on how to add external devices, see [“External devices”, page 138](#).

Complete vs relative

Complete presets will clear the entire scene and make a new scene exactly the way it was when it was stored in the preset.

Relative presets will add the parts that were saved in the preset to the current scene. Any additional layers or mix background layer hidden from the preset will remain as is.

7.10.12.1 Creating a preset

Location

1. **Navigation side bar:** *Programming*
2. **Central work area:** *PREVIEW* or *PROGRAM*
3. **Right panel:** *Preset*

Prerequisites

Create a desired scene in the central work area. For more information, see [“Scene creation”, page 124](#).

How to create

1. Select the desired destinations from the top panel or layout group from the bottom panel.
2. Decide how the preset must be created in *Preset Creation*.



Tip: If the options are hidden, then click the arrow ()

- ▶ Click the radio button in front of the desired preset type. Default is *Complete*.

- ▶ Check the check box in front of *Rename* if the created preset will be named immediately. (**optional**)
- ▶ Check the check box in front of *Lock* if the preset must be locked for editing. (**optional**)

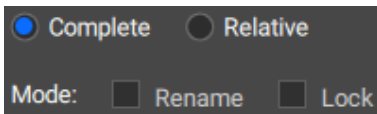

Image 7-144

3. Must the scene in preview or program be stored?
 - ▶ In case of **preview**, click *Save from PVW*.
 - ▶ In case of **program**, click *Save from PGM*.



 *Tip:* If an unlocked () entry is selected, then it can be overwritten with the overwrite button.



Image 7-145

The preset will be created and added to the list under *All Presets*.

4. Was the option *Rename* selected?
 - ▶ If **yes**, enter a name for the preset.
 - ▶ If **no** and the preset is **unlocked** () , double click on the name and enter a name.



 *Tip:* Provide clear names that reflect the intended purpose.



Image 7-146

5. Double click on the number in front of the preset and enter a desired number. (**optional**)

 *Note:* Numbers must be unique.

 *Tip:* Up to two decimal numbers are allowed.

 *Tip:* The automatic numbering will ignore decimal numbers and add one to the highest whole number in the list.



 *Tip:* The number decides at which position it is located in the list.



Image 7-147

6. Must the preset be available on other systems in the same network?

- ▶ If **yes**, click the global preset icon () .
- ▶ If **no**, go to next step.

7. Click the save icon () in the header.

7.10.12.2 Recalling a preset

Location

1. **Navigation side bar:** *Programming*
2. **Central work area:** *PREVIEW*
3. **Right panel:** *Preset*

About recalling

Presets can be recalled to any selected destination or layout group. Presets always recall to the preview section, never the program section. This allows time for conflicts to be resolved without affecting the displayed image.

How to recall

1. Must the preset be transitioned to program the moment it is recalled?
 - ▶ If **yes**, turn the slider before *Preset to PGM* on.
 - ▶ If **no**, turn the slider before *Preset to PGM* off.

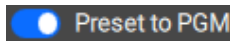

Image 7-148

2. Must the preset be recalled the moment it is selected?
 - ▶ If **yes**, turn the slider before *Auto Recall* on.
 - ▶ If **no**, turn the slider before *Auto Recall* off.

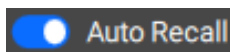

Image 7-149

3. Select a preset from the list.

If *Auto Recall* is turned on, then the preset will be applied to the preview of the destination(s).

4. Recall the desired preset.
 - ▶ For the preset one entry **above** the selection, click *Recall Previous*.
 - ▶ For the **selected** preset, click *Recall Current*.
 - ▶ For the preset one entry **below** the selection, click *Recall Next*.



Tip: The buttons will be red when *Preset to PGM* is turned on.

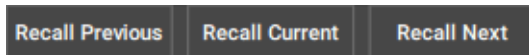

Image 7-150

The preset will be recalled.

5. Click the save icon () in the header.

7.10.13 Transitioning a scene

Location

1. **Navigation side bar:** *Programming*
2. **Right panel:** *Transition*

About transitions

Transitions move the scene from preview to program. There are two types of transitions:

- **Cut** transitions, where the transition is instant.
- **Animated** transitions, where the transition animations and layer movements are played over a defined period of time. For more information on how to configure layer movement, see [“Applying a move animation”, page 131](#).

How to cut transition

Cut transitions are executed on all selected destinations from the top panel or destination group from the bottom panel the moment the button *CUT* in the right panel ([Image 7-151](#)) or the button *Cut* in the bottom panel ([Image 7-152](#)) is clicked.



Image 7-151



Image 7-152

How to transition with crossfade

1. Select the desired destinations from the top panel or layout group from the bottom panel.
2. Enter the time interval in frames in the right panel (Image 7-153) or the bottom panel (Image 7-154) using the one of the following methods:
 - ▶ **Entering a value:** enter any desired value between 0 and 1999 in the input field.
 - ▶ **Using the + and - buttons:** click on the + to **increase** the value with one point and on the - to **decrease** the value with one point.

 **Note:** All steps must be done in the same panel. If one step is done in the right panel, then all following steps must also be done in the right panel.

 **Tip:** By default the crossfade will take 30 frames.



Image 7-153

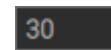

Image 7-154

3. Select the crossfade style from the drop down in the right panel (Image 7-155) or the bottom panel (Image 7-156).

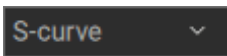

Image 7-155

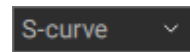

Image 7-156

4. Click the *ALL TRANS* button (Image 7-157) in the right panel or the *Trans* button (Image 7-158) in the bottom panel.

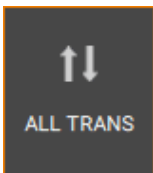

Image 7-157



Image 7-158



All armed animations and the crossfade will play and the preview scene will be shown on program.

7.10.14 Playing cues

Location

1. **Navigation side bar:** *Programming*
2. **Right panel:** *Cues*

About cues

Any selected cue can be started () , paused () and stopped () with the buttons in the right panel. To create or modify the cue, see [“External devices & cues”](#), page 138.

7.11 External devices & cues

About this chapter

The external devices & cues tab () lets a user control and use another device on the network from Event Master Toolset. These actions can be timed with actions of the Encore3 itself. Allowing for automation across different devices.

The possible external devices & cues settings and features will be explored in the following chapters.

7.11.1 External devices

Location

1. **Navigation side bar:** *External Devices & Cues*
2. **Left panel:** *Device(s)*
3. **Right panel:** *Configuration > External Device Info*

About external devices

Event Master Toolset can connect to virtually any network connected device. These devices are categorised in the following sub groups of the left panel:

- Other **Event Master devices**, including older and future Event Master solutions.
- **Barco projectors**, with standard commands automatically available.
- Other external devices.

About auto detect

Compatible network devices will automatically be detected by Event Master Toolset. These devices will be added under the category *Auto Detected* of the left panel. Barco devices will automatically have standard commands available. To add additional commands to these devices, see [“Creating commands”, page 139](#).

Copying external devices

Creating a copy of an external device will create a new entry with the exact same settings and commands. This exact copy can then be edited to refer to another unit of a similar type. Removing the need to manually add every command and configuration multiple times.

Click the copy icon () next to the name of the desired device.

Removing external devices

Select the desired device(s) in the left panel and click the delete icon () after the category name that the device is a part of. This will remove the device and **all configured commands**.



Hold **CTRL** or **⌘** to select multiple entries at once. If this does not work, enable the keyboard shortcuts in the settings. For more information, see [“Event Master Toolset options”, page 156](#).

How to add

1. Which type of device must be added?
 - ▶ In case of **Barco projector**, click *Add Barco Projector*.
 - ▶ In case of **Event Master device**, click *Add Other EM System(s)*, enter the IP address and click *Connect*.
 - ▶ In case of an **Event Master XML list**, click *Add EM XML*.
 - ▶ In all **other cases**, click *Add External Devices*.

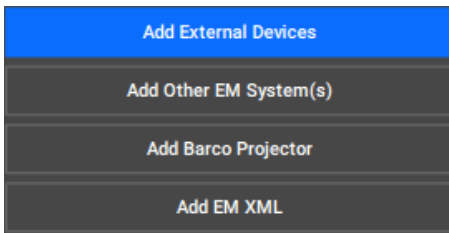



Image 7-159

An entry of the desired category is created.

2. Click on the created entry in the left panel.
3. Configure the device in the right panel.
 - a) Enter the desired number of the device after *Number*. (**optional**)
 - b) Enter the desired name of the device after *Name*.
 - c) Enter the IP address of the device after *IP Address*.
 - d) Enter the port where the commands must be sent after *Port*.
 - e) Select the protocol for the commands after *Protocol*.

 *Note:* Contact the local IT support for more information about the network fields.

 *Note:* Numbers must be unique.

 *Tip:* Up to two decimal numbers are allowed.

 *Tip:* The automatic numbering will ignore decimal numbers and add one to the highest whole number in the list.

 *Tip:* The number decides at which position it is located in the list.

 *Tip:* Provide clear names that reflect the intended purpose.

Number	2.00
Name	Barco projector2.00
IP Address	0.0.0.0
Port	9090
Number of Commands:	4
Protocol	<input checked="" type="radio"/> TCP <input type="radio"/> UDP <input type="radio"/> HTTP

Image 7-160

4. Click the save icon () in the header.

7.11.2 Creating commands

Location

1. **Navigation side bar:** *External Devices & Cues*
2. **Left panel:** *Device(s)*
3. **Right panel:** *Configuration > Command*

About command documentation

All Barco developed devices will communicate to Event Master Toolset using the REST API. For more information, see the reference guide on the Barco website:

- For Event Master devices, see <https://www.barco.com/en/support/docs/R5919184>.
- For all other Barco devices, see <https://www.barco.com/en/support>

For commands of devices that were not made by Barco, see the documentation of the manufacturer.

How to create

1. Click on a desired device in the left panel.
2. Must an existing command be overwritten?
 - ▶ If **yes**, select the desired command in the right panel and go to next step.
 - ▶ If **no**, go to next step.
3. Enter a name for the command after *Cmd Name* in the right panel.



Tip: Provide clear names that reflect the intended purpose.

4. Write the command that must be sent to the external device in the input field after *Code*.
5. Click *Test Command* to ensure the code works.

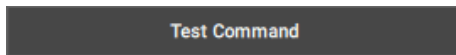

Image 7-161

6. Click *Save Cmd* or *Overwrite cmd*.

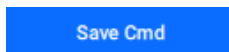

Image 7-162

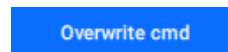

Image 7-163

7. Click the save icon () in the header.

7.11.3 Creating a cue

Location

1. **Navigation side bar:** *External Devices & Cues*
2. **Left panel:** *Device(s)*
3. **Right panel:** *Cues*

How to create

1. Decide how the cue must be created in *Creation Mode*. (**optional**)
 - ▶ Check the check box in front of *Rename* if the created cue will be named immediately.
 - ▶ Check the check box in front of *Lock* if the cue must be locked for editing.

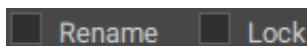



Image 7-164

2. Was the option *Rename* selected?
 - ▶ If **yes**, enter a name for the cue.
 - ▶ If **no** and the cue is **unlocked** () , double click on the name and enter a name.







Tip: Provide clear names that reflect the intended purpose.



Image 7-165

3. Double click on the number in front of the preset and enter a desired number. (**optional**)

-  *Note:* Numbers must be unique.
-  *Tip:* Up to two decimal numbers are allowed.
-  *Tip:* The automatic numbering will ignore decimal numbers and add one to the highest whole number in the list.
-  *Tip:* The number decides at which position it is located in the list.

1.15

Image 7-166

4. Click the save icon () in the header.

7.11.4 Managing actions

Location

1. **Navigation side bar:** *External Devices & Cues*
2. **Left panel:** *Device(s)*
3. **Right panel:** *Cues*

Prerequisites

The desired cue must be unlocked () and not be playing () nor paused () before edits can be made.

Removing an action

Click on the check box in the second column of the action that must be deleted and click *Delete Action* at the top.

Delete Action

Image 7-167

How to manage

1. Set the default wait time in frames after *Wait Time* at the top of the table in the central work area. (optional)

 *Note:* The wait time can take a maximum of 60000 frames.

 *Note:* By default the wait time is 29 frames.

29

Image 7-168

2. Click *Add Action* at the top of the table.

Add Action

Image 7-169

An additional row will be added to the bottom of the table.

3. Decide the command that must be executed using one of the following methods:
 - ▶ **Select** a device from the drop down in the column *Device List* and **select** the command from the drop down in the column *Commands*.

- ▶ **Drag** a device from the *Device(s)* in the left panel and **drop** them in the column *Device List* and **select** the command from the drop down in the column *Commands*.
- ▶ **Drag** a command from the *Device(s)* in the left panel and **drop** them in the *Commands* of the central work area.

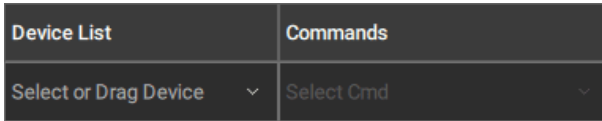

Image 7–170

4. Is the text in the variable column *N/A*?
 - ▶ If **yes**, Select the target variable from the drop down in *Select Var*.
 - ▶ If **no**, go to next step.

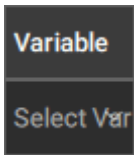

Image 7–171

5. Double click on the field in the *Name* column and enter a desired name.



Tip: Provide clear names that reflect the intended purpose.

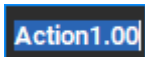

Image 7–172

6. Double click on the field in the *Wait Time* column and enter a desired time in frames.



Note: The default wait time specified at the top of the column will be entered by default.



Image 7–173

7. Decide what must be done after the wait time in the column *Parameters*.
 - ▶ *NEXT*, starts the following row.
 - ▶ *PAUSE*, pauses the cue until it is resumed.
 - ▶ *DELAY*, waits an additional specified frames before continuing. (by default, the specified wait time is entered)
 - ▶ *GOTO*, jumps to the specified action from a specified cue.
8. Are all desired actions added?
 - ▶ If **yes**, go to next step.
 - ▶ If **no**, repeat from step 2.



Note: Maximum of 12 actions can be added per cue.



Tip: If more than 12 actions are needed, set the last action to the start of a second cue.

9. Reorder the cue using one of the following methods:
 - ▶ Drag the field in the first column of the desired row and drop it on the desired location.
 - ▶ Double click on the number in the *#* column and enter the desired placement of the row.



Note: Numbers must be unique.



Note: Moving a column will change its number to reflect its new position. If that number is already in use, then the move cannot be done with drag and drop.

 *Tip:* Up to two decimal numbers are allowed.

 *Tip:* The rows are always sorted from lowest to highest number in the # column.



Image 7-174



Image 7-175

10. Use the play () , pause () and stop () buttons at the bottom of the right panel to test the cue.
11. Click the save icon () in the header.

7.11.5 Scheduling a cue

Location

1. **Navigation side bar:** *External Devices & Cues*
2. **Right panel:** *Cues* or *Time*

About scheduling a cue

Scheduling automatically starts cues that need to be played on a regular predictable time frame. Time frames depend on a configured time source that is either on the network or configured in the unit. For more information on time settings of a unit, see [“Time setting”, page 99](#).

About startup cue

A startup cue is automatically run once the Encore3 is powered on. This cue is intended to wake up any connected devices and prepare everything to start operations automatically. However, any user created cue can be set as a startup cue.

Select any desired cue from the drop down after *Startup Cue*.

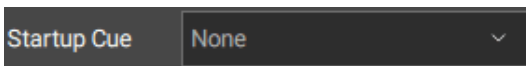

Image 7-176

How to schedule

1. Select the source of the time from the drop down after *Time Source* in the *Time* tab of the right panel.

 *Note:* If the *Time Source* is 'Off', then scheduling cannot be used.



Image 7-177

2. Click on the calendar icon () of the desired cue in the *Cues* tab of the right panel.
A schedule menu will be shown.
3. Set the desired time frame using the schedule menu.

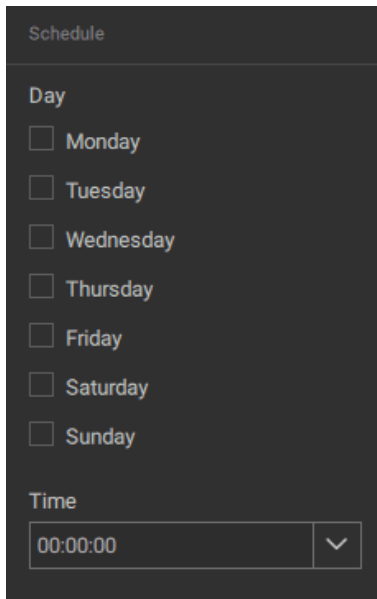

Image 7-178

- Click **Save** in the schedule menu.

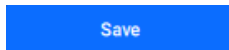



Image 7-179

The selected time will be added under the name of the cue.

- Check () the check box in front of the desired schedule or in front of *Schedule All* to activate the cue. The cue will play all checked time entries at the chosen intervals each week.
- Click the save icon () in the header.

7.12 Tally

About this chapter

The tally tab () allows for the management of external tally lights over the network. The possible tally settings and features will be explored in the following chapters.

7.12.1 Configuring a tally

Location

Navigation side bar: *Tally*

About tally

Up to 64 tally lights can be automatically managed through Event Master Toolset. These tally lights must be connected to a single network connected hub.

How to configure

- Select the desired command protocol from the drop down after *Tally IP Protocol*.



Tip: Selecting *OFF* will disable the tally protocol.

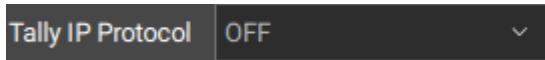

Image 7-180

2. Enter the IP address of the tally hub in the input field after *Tally IP Address*.

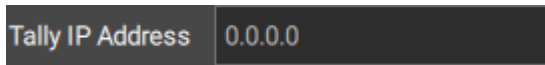

Image 7-181

3. Enter the desired port number after *Port*.



Image 7-182

4. Click the save icon () in the header.

7.12.2 Tally assignment

About tally assignment

Each input can be assigned to a tally. This tally can have different functionality for each possible destination. The following functionalities are possible:

- *None*, the tally light will always be **off**.
- *PGM*, the tally light will turn **red** when the input is in **program** of the **destination**.
- *PVW*, the tally light will turn **green** when the input is in **preview** of the **destination**.
- *PGM-PVW*, the tally light will turn **red** when the input is in **program** and **green** when the input is in **preview** of the **destination**.

Clearing all assignments

If all assignments in the table must be reset to *None*, then click the *Clear All Tally Data* at the top of the *Tally Protocol Assignment* table.

Image 7-183

How to assign

1. Select the desired input for each tally in the drop down of column *Resources*.



Tip: Selecting *None* as input will disable the tally protocol for that tally number.

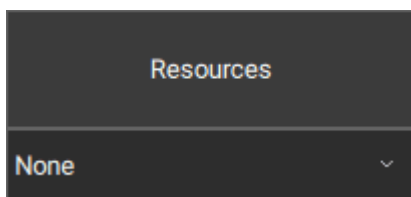

Image 7-184

2. Set the desired functionality using one or multiple of the following methods:
 - ▶ **Single assignment**, select the desired functionality from the drop down menu shared between the desired destination and desired tally. Go to step 6.
 - ▶ **Bulk destination assignment**, select the desired functionality from the drop down below the destination name. Go to step 6.
 - ▶ **Bulk tally assignment**, go to next step.
3. Select the desired functionality from *Set bus combo* in the right panel.

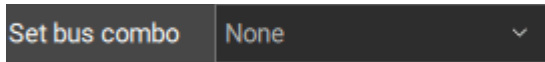

Image 7-185

4. Enter the start and end number of the desired range in the fields after *From Tally Start#* and *End#* using one of the following methods:
 - ▶ **Entering a value:** enter any desired value between 1 and 64 in the input field.
 - ▶ **Using the + and - buttons:** click on the + to **increase** the value with one point and on the - to **decrease** the value with one point.

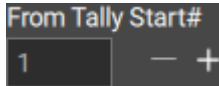

Image 7-186

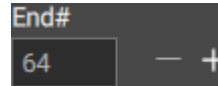

Image 7-187

5. Click *Apply*.

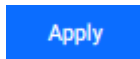

Image 7-188

All entries in each row of the range will have the selected functionality.

6. Test the tally configuration. (**optional**)
 - a) Select *All ON* from the drop down after *Test Tallies*.
The light on each assigned tally resource will be turned on.
 - b) Verify the tally lights are working as intended.
 - c) Select *OFF* from the drop down after *Test Tallies*.

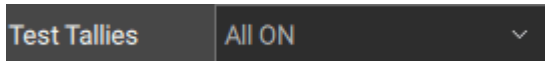

Image 7-189

7. Click the save icon () in the header.

7.13 Controller

About this chapter

The controller tab () allows a user to manage the layout and custom functions of a connected controller. For general controller settings, see [“Controller settings”, page 157](#).

The possible controller mappings and features will be explored in the following chapters.

7.13.1 Getting started

About mapping

Not all buttons on a controller can be mapped by the user. These fixed buttons will always derive their functionality from the general configuration in Event Master Toolset.

For more information on how each button functions, see [“Using Event Master controllers”, page 159](#).

About virtual console

The virtual console simulates an Event Master controller. Which controller is being simulated can be selected next to the layout drop down. Layouts and button mappings can be customised to this virtual controller. Clicking any button will execute the functionality as if it was being pressed on a real controller.

For more information on how to use the controller, see the following chapters.

About auto mapping

Auto mapping will automatically assign the first available button when new functionality is created in Event Master Toolset. Auto mapping only works for assign buttons. For more information about assign buttons, see [“Assign buttons”, page 162](#).

This setting can be toggled by clicking the *Auto Mapping Assign Bus* slider in the left panel.



Image 7–190

About color

Each button dedicated display uses background color to convey its current functionality. It is possible to put this color as the font color with a black background as opposed to the default colored background with a black font color. For more information about color, see [“Color”, page 160](#).

This setting can be toggled by clicking the *Swap LCD Text/BG color* slider in the left panel.

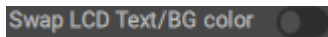

Image 7–191

7.13.2 Assign mapping

Location

Navigation side bar: *Controller*

Methods of assigning

There are two ways functionalities can be assigned to the controller:

- **Automatic**, will assign all available entries of a category in the corresponding category of the assign buttons. Each entry will be added in order. For more information about the assign buttons, see [“Assign buttons”, page 162](#).
- **Manual**, allows the user to decide which options are available and where.

How to automatically assign

1. Select the desired console at the top of the central work area.



Tip: In case of a virtual console, select the desired Event Master controller.

2. Select the desired category in the left panel.



Tip: Some categories have sub categories as well.

3. Enter the start and end number of the desired range in the fields after *Start #* and *End #*.

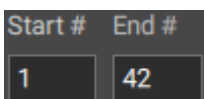

Image 7–192

4. Enter the desired page where the assigning must start using one of the following methods:
 - ▶ **Entering a value:** enter any desired value in the input field.
 - ▶ **Using the + and - buttons:** click on the + to **increase** the value with one point and on the - to **decrease** the value with one point.



Tip: If the range contains more entries than available buttons on the page, then the additional entries will be added to the next page.

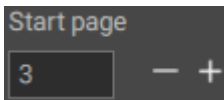

Image 7-193

5. Click the blue *Assign* button.
6. Click the save icon (📁) in the header.

How to manually assign

1. Select the desired console at the top of the central work area.
 - 👉 *Tip:* In case of a virtual console, select the desired Event Master controller.
2. Select the desired category in the left panel.
 - 👉 *Tip:* Some categories have sub categories as well.
3. Must the mapping be done to an assign button?
 - ▶ If **yes**, click on the functionality button of the desired row until the desired category is shown on the dedicated display and go to next step.
 - ▶ If **no**, go to step 5.
4. Must the mapping be done on a specific page?
 - ▶ If **yes**, navigate to the desired page using the navigation arrows in the desired row and go to next step.
 - ▶ If **no**, go to next step.
5. Drag the desired functionality from the left panel to the desired button in the central work area.
 - 👉 *Tip:* If the button supports the functionality, then it will flash while hovering over it.

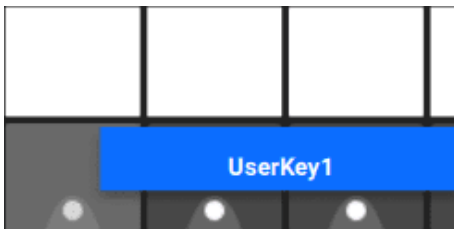

Image 7-194

The button dedicated display will show the name and color of the dropped functionality.

6. Click the save icon (📁) in the header.

7.13.3 Deleting mapping

Location

Navigation side bar: *Controller*

How to delete

1. Click *Delete Mapping*.

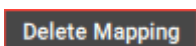





Image 7-195

Select Row buttons will appear next to each row that can be deleted.

2. Click on all buttons that must be deleted.

 *Tip:* If all assigned buttons must be deleted, then click the *Select Row* button before the desired row.

 *Tip:* Selections can be made across multiple pages.

 *Tip:* Clicking a button a second time, will stop the mapping from being deleted.

A trash icon () will be shown over each selection.

3. Click *Delete Selected* in the left panel.

 *Note:* This action cannot be undone.

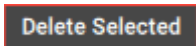

Image 7–196

7.13.4 Using the controller

Location

Navigation side bar: *Controller*

About using the controller

The controller can be used from Event Master Toolset as if it is a physical unit. This means that the virtual console can act as the controller. Keep in mind that no other version of Event Master Toolset can be opened at the same time. Therefore, any actions will be done blind. To prevent the actions being done blind, open a second window of Event Master Toolset. For more information, see [“About the user interface”, page 84](#).

For more information on how each button functions, see [“Using Event Master controllers”, page 159](#).

7.14 ShowFile

About this chapter

The ShowFile tab () allows for the creation and restoration of backups. These backups can be restored partially, using the ShowFile editor, or fully depending on the settings and information required.

The possible ShowFile settings and features will be explored in the following chapters.

7.14.1 Backup

Location

1. Navigation side bar: *ShowFile*
2. *Backup*

How to backup

1. Click on *Save*.

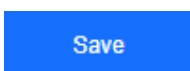

Image 7–197

A progress bar will appear at the bottom of the table.

2. Store the ShowFile in the desired location using the pop-up.

7.14.2 Restore

Location

1. **Navigation side bar:** *ShowFile*
2. *Restore*

How to restore

1. Navigate to the ShowFile by clicking the *Browse* button.

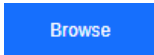

Image 7-198

The chosen ShowFiles name will be shown.

2. Click on *Restore*.

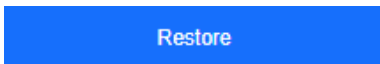

Image 7-199

A confirmation pop-up is shown.

3. Click on *Restore & Reboot* to recall all settings from the ShowFile.



Note: All the current settings will be overwritten. This action cannot be undone.



Tip: If only certain settings must be restored, then see [“ShowFile editor”, page 150](#).

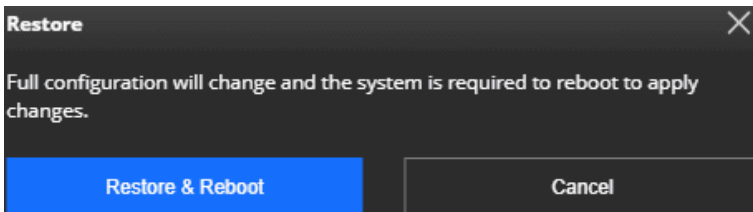

Image 7-200

The reboot may take several minutes.

7.14.3 ShowFile editor

Location

1. **Navigation side bar:** *ShowFile*
2. *ShowFile Editor*

About ShowFile editor

Sometimes not all settings must be restored from a backup file. With ShowFile editor it is possible to select specific user created content from a backup. Any selected content will be combined with any current configuration.

The following content can be selectively imported:

- Custom formats
- EDID files
- HDR files
- External devices and their commands
- Presets
- User keys
- Cues

How to import

1. Navigate to the ShowFile by clicking the *Browse* button.

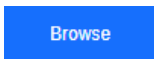

Image 7–201

The chosen ShowFiles name will be shown.

2. Click on the name of the ShowFile to show the available categories.
3. Must an entire category be imported?
 - ▶ If **yes**, click the check box after the name of the category and go to step 5.
 - ▶ If **no**, click on the name of the category and go to next step.
4. Click the check box in front of each desired content.
5. Must another category be fully or partially imported?
 - ▶ If **yes**, go to step 3.
 - ▶ If **no**, click *Import*.

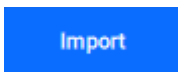



Image 7–202

The selected entries will be added.

6. Click the save icon () in the header.

7.15 Network

About this chapter

The network tab () provides an overview of the IP addresses and status of all compatible devices detected on the network.

The possible network settings and features will be explored in the following chapters.

7.15.1 Managing network settings

Location

Navigation side bar: *Network Settings*

About IP address

Two main methods for IP configuration are possible:

- **Static mode**, sets the Encore3 to a fixed IP address that is user defined.
- **DHCP mode**, means the Encore3 will request an IP address from the DHCP server of the network it is connected to.

Connection indicator

The Encore3 will automatically test the signal validity and speed of any cable connected to the 'Control' port. Results of this test will be shown in the indicator with the following states:



The indicator only signals the quality of the connected cable. Other issues can prevent the Encore3 from connecting to the network. For more information, see "[Troubleshooting abnormal Encore3 behavior](#)", page 172.

Indicator	Speed (Mbps)	Description
Red	0	No connection detected
Green	0 - 1000	Slower connection detected
Green	1000+	Faster connection detected

How to configure

1. Select the desired unit from the list.
2. Select the desired mode from the drop down box below *IP Mode* in the *Adjust Settings* tab.
 - ▶ In case of **DHCP**, go to step 4.
 - ▶ In case of **Static**, go to next step.

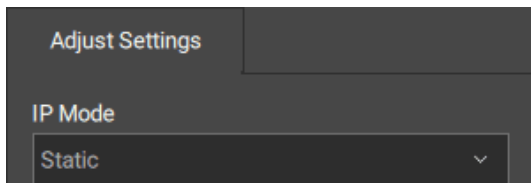

Image 7–203

3. Fill out the required network information. For more information, contact the local IT department.
4. Click *Apply Changes*.



Note: If the new IP settings are incorrect or no longer part of the same network, then Event Master Toolset will no longer be able to detect and modify the unit. Any other IP modifications will need to be done through the web page or the front panel of the unit itself.

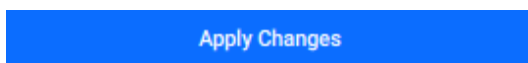

Image 7–204

The row of the unit will be updated with the new IP information.

7.16 Widget

About this chapter

The widget tab (🖱️) lets the user configure the available widgets. Widgets can be used on the web page, front panel or any other device that can access a website.

The possible widget settings and features will be explored in the following chapters.

7.16.1 Creating a widget

Location

1. **Navigation side bar:** *Widget*
2. **Left panel:** *Widget Settings*

How to create

1. Click the + *Create New Widget* button in the central work area.

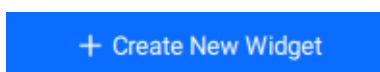

Image 7–205

2. Enter a name for the widget after *Widget Name*.



 *Tip:* Provide clear names that reflect the intended purpose.



Image 7–206

3. Select the desired size for the widget.
 - ▶ *HD* (1920x1080)
 - ▶ *UHD* (3840x2160)
 - ▶ *Front Panel* (800x480)

 *Note:* If the widget will be used on the front panel, then the 800x480 size of the widget will be required. Larger sizes cannot be displayed on the front panel.

4. Click the *Save Widget* button.





Image 7–207

5. Select the desired page to point the widget link to that page.

 *Note:* The widget link will be required to use the widget with a desired device.

6. Click the save icon () in the header.
7. Customise the created widget. For more information, see [“Editing a widget”, page 153](#).

7.16.2 Editing a widget

Location

1. **Navigation side bar:** *Widget*
2. **Right panel:** *Functions*
3. **Left panel:** *UI Components*

Template widgets

Event Master Toolset generates two template widgets that have standard layouts with some buttons. These templates can be used as a start point to create a custom widget, or they can be used as widgets.

How to edit

1. Click *Open* on the desired widget or template.

 *Tip:* The *Open* button will only be visible once the mouse hovers over the widget.

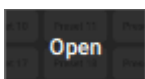

Image 7–208

The widget page will open.

2. Must a label or function be added to the widget?
 - ▶ In case of a **label**, drag the *T* from the top of the widget in the central work area and drop it in the widget window in the central work area.
 - ▶ In case of a **function**, drag the desired function from the left panel and drop it in the widget window in the central work area.

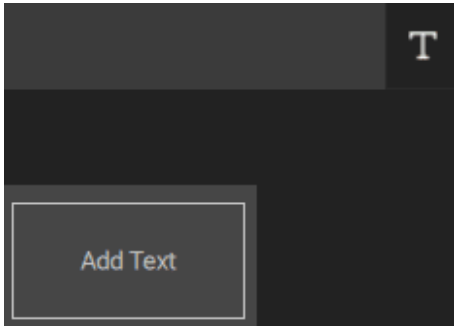



Image 7-209



Image 7-210

3. Adjust the position of the dropped element using one or both of the following methods:
 - ▶ Drag and drop the label or function in the desired location within the widget.
 - ▶ Modify the elements absolute *H Position* and *V Position* with the right panel using one of the following methods:
 - **Using the slider:** drag the white ball over the slider until the desired amount is reached.
 - **Entering a value:** enter any desired value in the input field.
 - **Using the + and - buttons:** click on the + to **increase** the value with one point and on the - to **decrease** the value with one point.

 *Note:* Widget elements are not allowed to overlap.

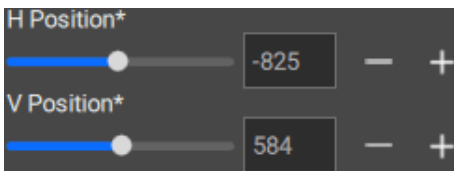





Image 7-211

4. Change the size of the element using one or both of the following methods:
 - ▶ Drag the edge of the element within the widget.
 - ▶ Modify the elements absolute *H Size* and *V Size* with the right panel using one of the following methods:
 - **Using the slider:** drag the white ball over the slider until the desired amount is reached.
 - **Entering a value:** enter any desired value in the input field.
 - **Using the + and - buttons:** click on the + to **increase** the value with one point and on the - to **decrease** the value with one point.

 *Tip:* The link icon () will ensure the aspect ratio of the element remains the same. The unlink icon () means the aspect ratio can change.

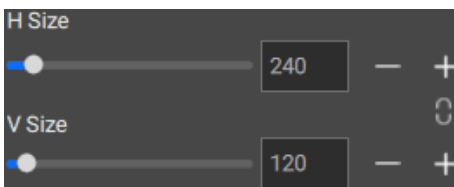

Image 7-212

5. Modify the appearance of the element using the following three settings:
 - ▶ *Color*, only available for **function** elements.
 - ▶ *Border*, only available for **function** elements.
 - ▶ *Text*, available for **all** elements.

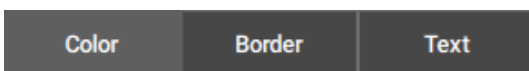

Image 7-213

6. Must additional functions be added?

- ▶ If **yes**, repeat from step 2.
- ▶ If **no**, go to next step.

7. Select multiple entries in the widget window that must be aligned. (**optional**)



Tip: Hold **CTRL** or ⌘ to select multiple entries at once. If this does not work, enable the keyboard shortcuts in the settings. For more information, see “[Event Master Toolset options](#)”, page 156.

8. Align the selections with each other using the right *Button Position*. (**optional**)



Note: Some options are only available when three or more layers are selected.



Image 7-214

9. Must another page be modified?

- ▶ If **yes**, click on the desired page at the bottom of the central work area and go to step 2.
- ▶ If **no**, go to next step.

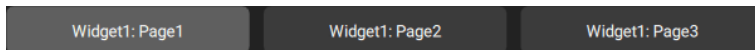

Image 7-215

10. Click the save icon () in the header.

11. Click on the blue text *Widget Panel* at the top of the central work area to return to the widget panel homepage.



Image 7-216

Any unsaved changes will be lost.

7.16.3 Using a widget

Location

1. **Navigation side bar:** *Widget*
2. **Right panel:** *Widget Settings*

About using a widget

Widgets can be used on any network device with a browser, on the front panel or using the web page. For more information, see “[Widget panel](#)”, page 63 of the front panel or “[Widget panel](#)”, page 69 of the web page. To use the widgets with Event Master Toolset, open the settings category and use the widgets through the web page. For more information, see “[Unit web page](#)”, page 156.

How to use on a device

1. Click *Open* of the desired widget or template.



Tip: The *Open* button will only be visible once the mouse hovers over the widget.

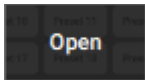

Image 7–217

2. Select desired page from the list under *Pages*.

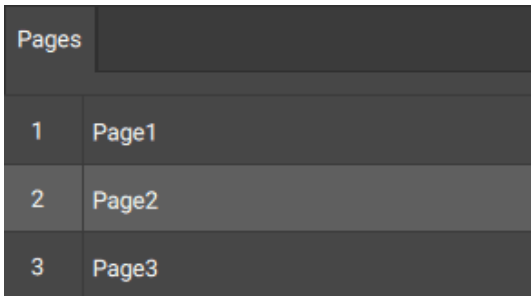



Image 7–218

3. Copy the link to the widget from *Link to Widget* by clicking the copy icon ()
4. Enter the link in a browser of choice on the desired device.
5. Click or tap on any button to activate its function.

7.17 Settings

About this chapter

The settings tab () contains general settings for Event Master Toolset, any connected device or controller. The possible settings and options will be explored in the following chapters.

7.17.1 Unit web page

Location

Navigation side bar: *Settings*

About unit web page

Opening the setting page will load the web page of the current system host unit in the central work area. For more information on how to use the web page, see [“Encore3 web page”, page 67](#).

There are two ways to see the web page of any other system or units connected to Event Master Toolset:

- Change the system or unit with the drop downs in the header.
- Select the desired system in the *Devices* tab of the right panel.

7.17.2 Event Master Toolset options

Location

1. **Navigation side bar:** *Settings*
2. **Left panel:** *Options*

About Event Master Toolset options

Settings that affect the entire Event Master Toolset application can be found here. Enable any desired setting by turning the slider on. Disable any unwanted settings by turning the slider off.

Language selection

Event Master Toolset can be displayed in various languages. By default, every installation comes with the following languages:

- English
- French
- Chinese

Selecting the desired language from the drop down, will change the menu text across the entire interface to that selected language. Any names or user created text will not be translated.

If another language or regional variation is needed, then request a custom language file from Barco support. This language file can then be loaded into Event Master Toolset by selecting the *Custom* language from the drop down.

Keyboard shortcuts

Event Master Toolset has shortcuts that can be used to simplify certain actions. If shortcuts are enabled, then all shortcuts mentioned in the list will execute once their assigned button is pressed on a keyboard. These shortcut buttons cannot be remapped.



If the list is hidden, then click the arrow (▶).

Reset

Click the *Reset Event Master Toolset* button to restore all settings to their default state.



 A blue rectangular button with a white circular arrow icon on the left and the text "Reset Event Master Toolset" in white.

Image 7-219

7.17.3 Controller settings

Location

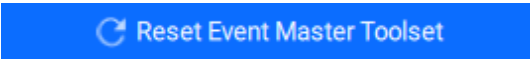
1. **Navigation side bar:** *Settings*
2. **Right panel:** *Controller*

About controller settings

General information and settings for the connected controller can be found here. Different user preferences (for example: brightness levels), menus, diagnostics (for example: pixel tests) and informations (for example: firmware version) will be available depending on which controller is connected.

Using Event Master controllers

8

8.1	Color	160
8.2	Destination buttons	160
8.3	Layer buttons	161
8.4	Assign buttons	162
8.5	Transition buttons	164
8.6	User assigned buttons	164
8.7	T-bar	165
8.8	Built-in touch screen	165

About this chapter

How to best use a connected Event Master controller will be explored in the following chapters.

About Event Master controllers

The controllers are intended to work alongside the Event Master Toolset. With Event Master Toolset, buttons can be configured to have different functionalities or be synced with the scenes that have been prepared.

8.1 Color

About button color

Color is used to convey a state or function of a button. The color can be present on the keycap or with an LED shining through a cutout of the keycap. There are two main types of buttons:

- **Solid colored buttons**, predefined buttons that have a **fixed** functionality.
- **Black buttons**, flexible buttons that have **changing** functionalities.

Overview button color

Color	Button meaning (keycap)	Button state (cutout LED)
Blue	Layer freeze	Selected destinations
Green	Button affects preview	<ul style="list-style-type: none"> • Preview select • Function inverted
Red	Button affects program	Selection on program
Black	Not predefined	N/A

About button dedicated display color

Some buttons have accompanying displays. These dedicated displays use a background color to signal the current assigned functionality. This background color can be set as the text color using Event Master Toolset. For more information, see ["Getting started", page 146](#).

Overview button dedicated display color

Color	Functionality
Green	Background source
Cyan	Cue
White	Preset
Yellow	Source
Magenta	User key
Red	Loss of signal

8.2 Destination buttons

Availability

- **Models:** All
- **Count:** 12 with 8 virtual pages

Elements

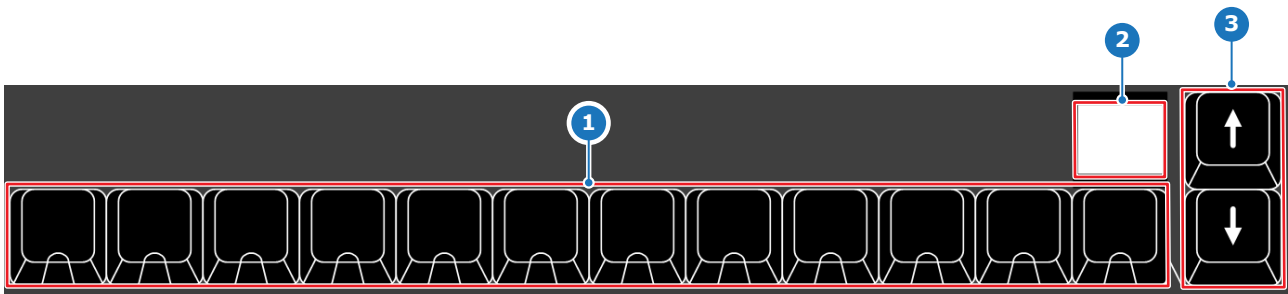

Image 8-1

- 1 Destination buttons with cutout LEDs
- 2 Page display
- 3 Page up and page down buttons

Navigating virtual pages

There are two main methods of navigating pages:

- For **individual navigation**:
 - Press the page up button to go to the **next** page.
 - Press the page down button to go to the **previous** page.
- For **specific navigation**, while pressing and holding the page down button, press the destination button that corresponds with the desired page.

The current page is shown on the page display.



Changing pages on the controller will also update the contents of the destination name bar in Event Master Toolset.

Functionality destinations

Destination layers work on a toggle basis. Clicking the button will either set the destination as target for actions or remove it as target for actions. Multiple destinations can be selected at the same time. Target destinations will have the LED in the cutout turned on.

Which destination corresponds to which button on the controller can be seen with the destination name bar in the footer of the Event Master Toolset software. For more information, see [“About the user interface”, page 84..](#)

8.3 Layer buttons

Availability

- **Models:** All
- **Count:** 8 with 2 virtual pages

Elements

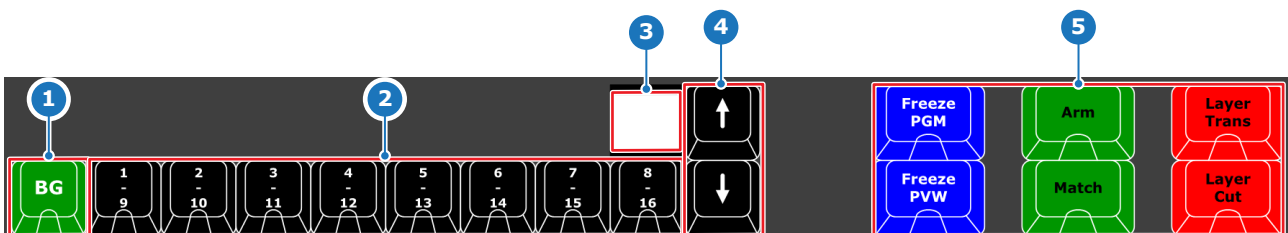

Image 8-2

- 1 Background button with cutout LED
- 2 Layer buttons with cutout LEDs
- 3 Page display
- 4 Page up and page down buttons
- 5 Layer command buttons

Virtual pages



Virtual pages are available when some or all layers are split.

Layers 1A - 8A are available on page one. Layers 1B- 8B are available on page two.

Navigating virtual pages

There are two methods of navigating pages:

- Press the page up button to go to the **next** page.
- Press the page down button to go to the **previous** page.

The current layers are shown on the page display.

Functionality mix background layer and layer buttons

Clicking any layer button will set the mix background layer or selected layer as target for modifications on the selected destination(s). This will remove any previous selection of layer(s).



Selecting multiple layers at once can be done using the custom layer mapping on either a flex button or user assigned button. For more information, see [“Assign buttons”, page 162](#) or [“User assigned buttons”, page 164](#).

Functionality layer command buttons

The layer command buttons contain frequently used functions that affect entire layers:

- *‘Freeze PGM’*, freezes the displayed signal of the selected layer(s) on the selected destination(s) in **program**.
- *‘Freeze PVW’*, freezes the signal of the selected layer(s) on the selected destination(s) in **preview**. The layers will remain frozen when sent to program.
- *‘Arm’*, causes the selected layer(s) on the selected destination(s) to use the predefined movement animation when transitioning from preview to program. Arming will do nothing if no move animation was defined. For more information, see [“Applying a move animation”, page 131](#).
- *‘Match’*, exactly copies the current layers of the selected destination(s) in program to preview.
- *‘Layer Trans’*, transitions the selected layer(s) on the selected destination(s) from preview to program. If *‘Arm’* was selected, the layers will preform the animation.
- *‘Layer Cut’*, cuts the selected layer(s) on the selected destination(s) from preview to program without any animation. *‘Arm’* status is ignored when using cut.

8.4 Assign buttons

Availability

- **Models:** All
- **Count:**
 - EC-30: 2 rows of 12
 - EC-50: 3 rows of 12

Elements

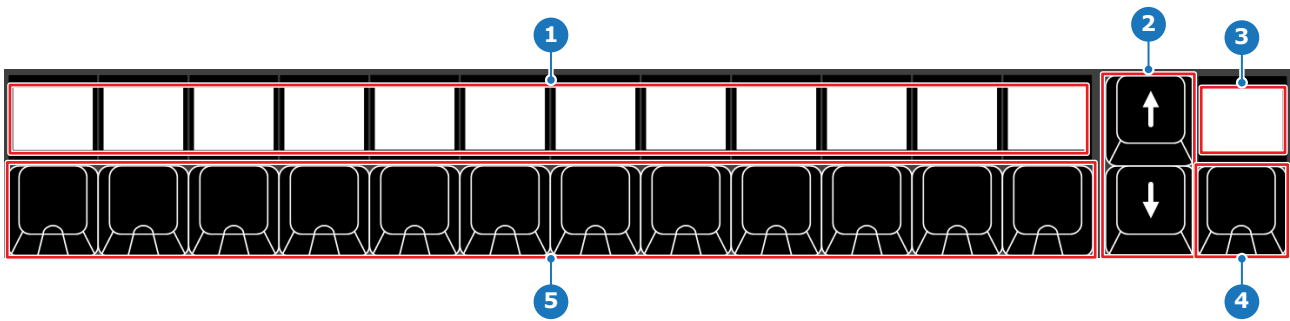

Image 8–3

- | | |
|------------------------------------------------------------------------------------------------------------------------------------------------|--------------------------------------------------------------------------------------|
| <p>1 Assign buttons dedicated displays</p> <p>2 Page up and page down buttons</p> <p>3 Functionality and page display</p> | <p>4 Functionality button</p> <p>5 Assign buttons with cutout LEDs</p> |
|------------------------------------------------------------------------------------------------------------------------------------------------|--------------------------------------------------------------------------------------|

Virtual pages

Different amount of virtual pages are available depending on the active category:

- ‘Source’ or ‘Preview Source’, 75 pages
- ‘Program Source’, 75 pages (**hidden by default**)
- ‘Preset’, 84 pages
- ‘Cue’, 10 pages
- ‘Flex’, 84 pages
- ‘UserKey’, 25 pages

Switching between the pages within a category can be done with the page up and page down buttons. The current virtual page will be shown under the current active category on the functionality and page display.

Navigating virtual pages

There are two main methods of navigating pages:

- For **individual navigation**:
 - Press the page up button to go to the **next** page.
 - Press the page down button to go to the **previous** page.
- For **specific navigation**:
 - To **jump to a multiple of ten**, while pressing and holding the page up button, press the assign button that corresponds with the tens digit of the desired page.
 - To **jump to one of the first 12 pages**, while pressing and holding the page down button, press the assign button that corresponds with the desired page.

The current page is shown under the current category on the functionality and page display.

Functionality selection

Each row can be assigned a predefined category. This category defines which settings or options can be assigned to the individual assign buttons. Click the functionality button to change the category of the entire row. When switching to a category, the last active virtual page will be recalled. If there is no last active virtual page, then the category will start on page one.

The available functionalities are:

- ‘Source’ or ‘Preview Source’: changes the source of the selected layer(s) on the selected destination(s) in preview. ‘Preview Source’ will be the name of the category when *Show program preview source bus* is enabled in the Event Master Toolset settings. For more information, see [“Event Master Toolset options”, page 156](#).
- ‘Program Source’ (**hidden by default**): changes the source of the selected layer(s) on the selected destination(s) in program. The option *Show program preview source bus* must be enabled in the Event Master Toolset settings. For more information, see [“Event Master Toolset options”, page 156](#).
- ‘Preset’: recalls a preset to the selected destination(s) in preview.
- ‘Cue’: starts a cue from the first defined action.

- 'Flex': can be any functionality.
- 'UserKey': recalls a user key to the selected layer(s) of the selected destination(s) in preview.

Functionality assign buttons

Clicking on an assign button will execute the action shown on the assign button dedicated display. This action will be executed on each selected layer of each selected destination.

By default Event Master Toolset will auto add all possible functions per category after each other. These layouts can be changed using Event Master Toolset. For more information, see ["Assign mapping", page 147](#).

8.5 Transition buttons

Availability

- **Models:** All
- **Count:** 2

Elements

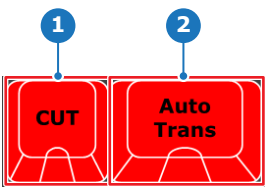

Image 8-4

- 1 Cut button
- 2 Transition button

Functionality

Transition buttons ignore selections of the layer buttons and affect all layers on the selected destination(s). Using 'CUT' will ignore the arm status while cutting the layers from preview to program. 'Auto Trans' will transition the layers from preview to program while playing any armed layers animations.

8.6 User assigned buttons

Availability

- **Models:** All
- **Count:**
 - EC-30: 1 row of 2
 - EC-50: 2 rows of 2

Elements

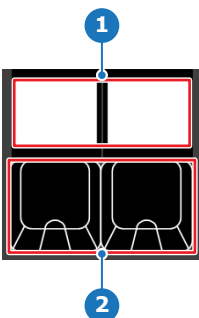

Image 8-5

- 1 Custom buttons dedicated displays
- 2 Custom buttons with cutout LEDs

Functionality

Custom buttons are additional flex buttons and can be assigned any functionality available. For more information on how to set the function of these buttons, see [“Assign mapping”, page 147](#)

8.7 T-bar

Availability

- **Models:** all
- **Count:** 1

Functionality

The transition bar or T-bar allows for the manual transition of content from preview to program. To transition, move the handle from the starting position, which can be either fully at the top (reference T) or fully at the bottom (reference B), to the opposite ending position. This will gradually fade out the content from program while the content from preview fades in. It is possible to go back to the starting position as long as the end position has not been reached. This will gradually fade out the preview content and fade in the program content. Once the end position has been reached, it becomes the starting position for the next transition.

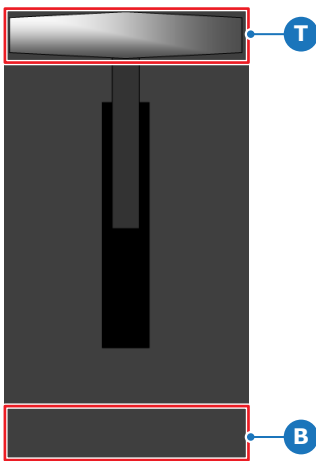

Image 8-6

- T** Top position
- B** Bottom position

8.8 Built-in touch screen

Availability

- **Models:** EC-50
- **Count:** 1

Functionality

The built-in touch screen display works as an extended display for the connected computer. This display is mainly intended to display either the Event Master Toolset software or a widget for additional buttons. However, it can function as any other computer monitor.

Service

9

9.1 Replacing the power supply

About the power supply

There are two power supplies present in the Encore3. Both are identical and follow the same procedure.

Required parts

Power supply

How to replace

1. Lift the lever (reference 1) and pull on the handle to remove the desired power supply.

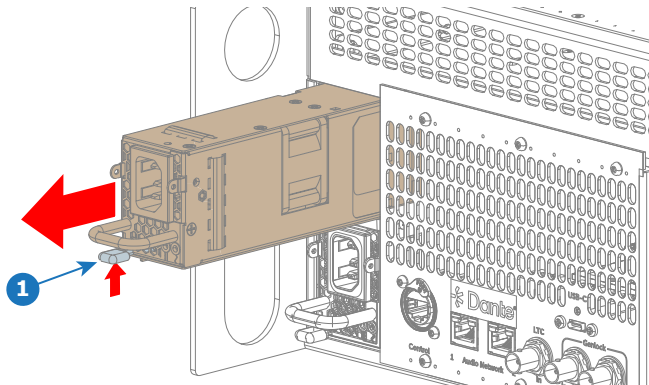

Image 9-1

2. Slide the new power supply into the desired slot as illustrated.



Note: Ensure the power supply is inserted all the way. An audible click can be heard when the power supply locks in place.



Caution: Do not use excessive force while inserting to avoid damaging the connectors.

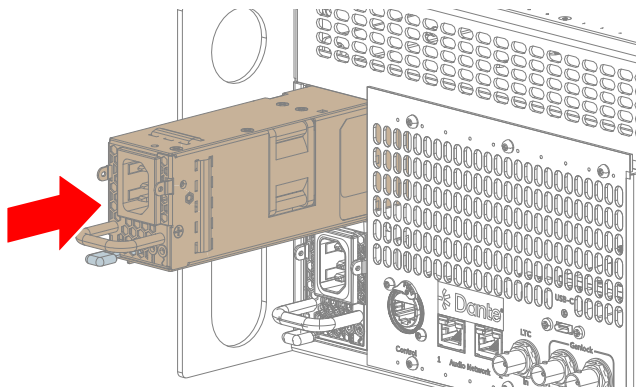

Image 9-2

Preventative maintenance

10

10.1 One-year maintenance actions	170
10.2 Four-year maintenance actions.....	170

About this chapter

Best practices on how to maintain and maximize the lifetime of the Event Master devices. It is strongly recommended to read the topics in this chapter attentively and preform the described actions regularly.

10.1 One-year maintenance actions

Perform every year

No.	Maintenance action	Remarks
1	Reseat all Event Master cards in the video processor.	Check the cards for possible damage. Replace any defective cards if necessary. For more information, see “ Removing an Event Master card ”, page 35.
2	Blow off dust from every Event Master device.	Avoid blowing the dust into the device.

10.2 Four-year maintenance actions



All following actions must be done by certified service personnel. Contact Barco customer service support for further assistance. For more information, see <https://www.barco.com/en/support>.

Perform every four years

No.	Maintenance action	Remarks
1	Reseat all Event Master cards in the video processor.	Check the cards for possible damage. Replace any defective cards if necessary. For more information, see “ Removing an Event Master card ”, page 35.
2	Perform a thorough cleaning both internal and external of the Event Master devices.	Check for any possible damage on internal components while cleaning. Replace damaged components if necessary.
3	Replace the internal battery.	The battery loses efficiency after four years and must be replaced.

Troubleshooting

11

11.1 Troubleshooting abnormal Encore3 behavior	172
------------------------------------------------------	-----

11.1 Troubleshooting abnormal Encore3 behavior

Unit does not start

Situation	Solution
Unit in standby.	Press the power button at the front of the Encore3. For more information, see "Waking the Encore3" , page 43.
Temperature problem.	Ensure the ambient temperature is within specifications. For more information, see "Installation requirements" , page 34.
Insufficient power delivery to the unit.	<ol style="list-style-type: none"> 1. Reseat the power cable. 2. Ensure the power cable is plugged into the wall socket. 3. Ensure integrity of the power cable. 4. Reseat the power supply.
Corrupt configuration of the software.	Factory reset the unit. For more information, see "Reset" , page 64.
Malfunction power supply.	Replace the power supply. For more information, see "Replacing the power supply" , page 168.
Malfunction power interposer.	Replace the power interposer. Contact Barco customer service support for further assistance. For more information, see https://www.barco.com/en/support .

Power supply not turning on

Situation	Solution
AC indicator LED is off: insufficient power delivery to the power supply.	<ol style="list-style-type: none"> 1. Reseat the power cable. 2. Ensure the power cable is plugged into the wall socket. 3. Ensure integrity of the power cable. 4. Reseat the power supply.
AC indicator LED is green, DC indicator LED is off or amber: malfunction power supply.	Replace the power supply. For more information, see "Replacing the power supply" , page 168.
Both indicators green: malfunction power interposer.	Replace the power interposer. Contact Barco customer service support for further assistance. For more information, see https://www.barco.com/en/support .

Unstable or noisy image

Situation	Solution
Temperature problem.	<ol style="list-style-type: none"> 1. Ensure the ambient temperature is within specifications. For more information, see "Installation requirements", page 34. 2. Run the temperature diagnostics and replace any card that fails. For more information, see "Temperature diagnostics", page 54.
Specific image is unstable or noisy: bad connection.	<ol style="list-style-type: none"> 1. Check and reseat the connections to the card with unstable or noisy image. 2. Reseat the card with unstable or noisy image. 3. Check and ensure the functionality of the attached peripheral on another device.

Situation	Solution
Specific image is unstable or noisy: malfunction card.	Replace the card with unstable or noisy image. For more information, see “ Removing an Event Master card ”, page 35.
Specific or all images are unstable or noisy: malfunction motherboard.	Replace the motherboard. Contact Barco customer service support for further assistance. For more information, see https://www.barco.com/en/support .

No communication between Event Master Toolset and unit over network

Situation	Solution
Wrong IP address.	Ensure the IP address of the unit and the entered IP address are the same.
Bad connection.	<ol style="list-style-type: none"> 1. Check and reseal the ethernet connection to the unit. For more information, see “Control connection”, page 40. 2. Ensure the connector indicator is green and speed is detected. For more information, see “Unit ID, IP address”, page 49.
Malfunction ethernet cable.	Replace the ethernet cable. For more information, see “ Control connection ”, page 40.
Network issue.	<ol style="list-style-type: none"> 1. Connect the unit to another port on the network. 2. Resolve the network issue. Contact the local IT department for network support.
Malfunction input board.	Replace the input board. Contact Barco customer service support for further assistance. For more information, see https://www.barco.com/en/support .

No communication between Event Master Toolset and unit directly

Situation	Solution
DHCP is enabled on the computer.	Disable DHCP and use a static network to connect to the unit. For more information, see “ Unit ID, IP address ”, page 49 or “ About ”, page 78.
Bad connection.	<ol style="list-style-type: none"> 1. Check and reseal the ethernet connection to the unit. For more information, see “Control connection”, page 40. 2. Ensure the connector indicator is green and speed is detected. For more information, see “Unit ID, IP address”, page 49.
Malfunction ethernet cable.	Replace the ethernet cable. For more information, see “ Control connection ”, page 40.
Network issue.	Resolve the network issue. Contact the local IT department for network support.
Malfunction input board.	Replace the input board. Contact Barco customer service support for further assistance. For more information, see https://www.barco.com/en/support .

Unit continuously reboots

Situation	Solution
Corrupt software.	<ol style="list-style-type: none"> 1. Factory reset the unit. For more information, see “Reset”, page 64. 2. Reload or upgrade the software. For more information, see “Firmware upgrade”, page 51.
Malfunction motherboard.	Replace the motherboard. Contact Barco customer service support for further assistance. For more information, see https://www.barco.com/en/support .

No read or write functionality with external USB drive

Situation	Solution
External USB drive issues.	<ol style="list-style-type: none"> 1. Reseat the external USB drive 2. Ensure the external USB drive is formatted in FAT32. Contact the local IT department for additional support on formatting. 3. Swap external USB drive.
Malfunction internal USB connection.	Replace the internal USB cable. Contact Barco customer service support for further assistance. For more information, see https://www.barco.com/en/support .

Internal display too dark

Situation	Solution
Brightness setting incorrect.	Ensure the brightness setting of the display is correct. For more information, see “Front panel”, page 50.
Internal display backlight degradation.	Replace the internal display. Contact Barco customer service support for further assistance. For more information, see https://www.barco.com/en/support .

Unresponsive front panel

Situation	Solution
Front panel is locked.	<ol style="list-style-type: none"> 1. Unlock the front panel using Event Master Toolset. For more information, see “Setup”, page 97. 2. Power cycle the unit.
Malfunction front panel.	Replace the front panel. Contact Barco customer service support for further assistance. For more information, see https://www.barco.com/en/support .

IP address lost after factory reset

Situation	Solution
Factory reset, save IP was not used.	Reconfigure the IP address of the unit. For more information, see “Unit ID, IP address”, page 49 or “About”, page 78.

Unable to perform web upgrade

Situation	Solution
No internet access.	Ensure internet access is available on the connected computer. Contact the local IT department for additional support.

Specifications

A

A.1	Event Master processor specifications	176
A.2	Input cards specifications	177
A.3	Output cards specifications	179
A.4	Link cards specifications	180
A.5	Event Master controllers specifications	180

A.1 Event Master processor specifications

Encore3 specifications:

Live effects canvas	Boundless canvas with 8x 4K60 PGM outputs
Video inputs	Up to 7 input capable card slots to occupy with Event Master Gen2 cards <ul style="list-style-type: none"> Each input card supports up to 4x 4K @60p inputs Standard Encore3 Configuration <ul style="list-style-type: none"> 16x 4K @60p inputs Up to 4x HD/3G/6G/12G SDI connectors Up to 9x HDMI™ 2.0 (up to 4096x2160 @60Hz) Up to 5x DisplayPort 1.2 (up to 4096x2160 @60Hz)
Video outputs	Up to 4 output capable card slots to occupy with Event Master Gen2 cards <ul style="list-style-type: none"> Each output card supports up to 4x 4K @60p outputs Standard Encore3 Configuration <ul style="list-style-type: none"> 8x 4K@60p outputs Up to 4x HD/3G/6G/12G SDI connectors Up to 5x HDMI™ 2.0 (up to 4096x2160 @60Hz) Up to 1x DisplayPort (up to 4096x2160 @60Hz)
Genlock	Analog reference input/Output on BNC connectors; bi-level and blackburst at SD and tri-level at HD
Program output	Up to 8 program outputs configurable as single screens or tiled/blended widescreens Configurable for up to 8x 4096 X 2160 @60p Independent edge blending/feathering control for all four sides
Scaled AUX outputs	User definable for up to 8x 4096 x 2160 @60p <ul style="list-style-type: none"> Each output card supports up to 2x AUX outputs
Mixers	<ul style="list-style-type: none"> Positionable non-scaled background mixer per output screen Independent layer transitions or full Preview/Program transitions Pre-assigned 4 mixable / 8 single (up to 16 mixable / 32 single) scalable PIP/key layers per output screen
Still stores	Store up to 2160MB (~60 4K60) of still images, supporting stills up to a staggering 160,000px in either horizontal or vertical dimensions
Layer effects	<ul style="list-style-type: none"> Borders (hard, soft, halo) and drop shadows Color effects Luma, chroma and Cut/Fill keys PIP moves via Keyframes
Multiviewer	<ul style="list-style-type: none"> 2x 4K @60p MultiViewer as source that be sent to any output or layer. Flexible user-definable layouts Monitor all Inputs and screens PVW & PGM
Expandability	Standard Encore3 Configuration includes: <ul style="list-style-type: none"> 1x Quad 100 G High Speed Expansion Link Card for system expansion; each link card supports 15* x 4K60 in & out per card 2x 100G QSFP28 2 meter DAC cables Encore3 ships with the ability to link 2 chassis for expansion at first release Link units to increase available Inputs and Outputs for larger tiled/blended widescreen applications Easily expandable for larger display applications via 4x QSFP28 link connection; quad 100G High Speed Expansion Link Card required.

HDCP	HDCP compliance determined by installed cards
Control	<ul style="list-style-type: none"> • Event Master Toolset (V10.x or later) for PC or MAC • Event Master controllers • WebUI • Ethernet RJ-45, 1000/100/10 Mbps autosense
Serviceability	<ul style="list-style-type: none"> • Field-Serviceable I/O cards (not hot-swappable) • Hot-swappable dual-redundant power supplies
Dimensions	<p>Height: 175.5 mm (6.9 in) - 4 RU rackmount</p> <p>Width: 431.8 mm (17.0 in) without chassis handles, 485.3 mm (19.1 in) with chassis handles attached</p> <p>Depth: 590.54 mm (23.3 in) from front panel to rear panel without handles or connector protectors, 672.29 mm (26.5 in) overall</p>
Weight	Standard config.: 29 kg / 64 lb Standard config shipped with flight case: 48.5 kg / 107 lb Empty chassis: 26.3 kg / 58 lb
Power	Input power: 100-240Vac, 50/60Hz, 12-5A (x2), 1,100 W Dual-redundant, hot-swappable power supplies
Environmental temperature	0-40° C / 32-104 F
Environmental humidity	0-95% non-condensing (non-operating) 0-85% non-condensing (operational)
Warranty	3 years parts and labor

A.2 Input cards specifications

H2.0 quad input card specifications:

Connectors	4x full sized HDMI™ connectors
Resolution	up to 2x 4096x2160@60p in (8L) slot
Color depth	8-bit; 10-bit; 12-bit (DL or lower)
Color sampling	up to UHD@60p 8-bit 4:4:4 or 10-bit 4:2:2
HDCP	HDCP 2.2 compliant
Signal capacity	600 MHz
Connectors*	4x full sized HDMI™ 2.0 connectors
Resolution*	Support up to 4x 4096x2160 @60Hz
Color depth*	8-bit; 10-bit; 12-bit
Color sampling*	up to UHD@60p 8-bit 4:4:4 or 10-bit 4:2:2
HDCP*	HDCP 2.2 compliant
Signal capacity*	up to 4096x2160 @60Hz
*	Specification when used with Encore3

DisplayPort1.2 quad input card specifications:

Connectors	4x full sized DisplayPort connectors
Resolution	up to 2x 4096x2160@60p in (8L) slot
Color depth	8-bit; 10-bit; 12-bit (DL or lower)
Color sampling	up to UHD@60p 4:4:4 10-bit
HDCP	HDCP 1.x compliant
Signal capacity	660 MHz
Connectors*	4x full sized DisplayPort connectors
Resolution*	Support up to 4x 4096x2160 @60Hz
Color depth*	8-bit; 10-bit; 12-bit
Color sampling*	up to UHD@60p 4:4:4 10-bit
HDCP*	HDCP 1.x compliant
Signal capacity*	up to 4096x2160 @60Hz
*	Specification when used with Encore3

Tri-combo input card specifications:

Connectors	1x DP 1.2; 1x HDMI™ 2.0; 4x 12G-SDI (BNC)
Resolution	Up to 2x 4096x2160@60p in (8L) slot
Color depth	8-bit; 10-bit; 12-bit (DL or lower)
Color sampling	HDMI™ 2.0: up to UHD@60p 4:4:4 8-bit DP1.2: up to UHD@60p 4:4:4 10-bit 12G-SDI: up to UHD@60p 4:2:2 10-bit
HDCP	HDCP 2.2 compliant on HDMI™ HDCP 1.x compliant on DisplayPort
Signal capacity	HDMI™: 600 MHz DisplayPort: 660 MHz
Connectors*	1x DP 1.2; 1x HDMI™ 2.0; 4x 12G-SDI (BNC)
Resolution*	Support up to 4x 4096x2160 @60Hz
Color depth*	8-bit; 10-bit; 12-bit
Color sampling*	HDMI™ 2.0: up to UHD@60p 4:4:4 8-bit DP1.2: up to UHD@60p 4:4:4 10-bit 12G-SDI: up to UHD@60p 4:2:2 10-bit
HDCP*	HDCP 2.2 compliant on HDMI™ 2.0 HDCP 1.x compliant on DisplayPort
Signal capacity*	up to 4096x2160 @60Hz
*	Specification when used with Encore3

A.3 Output cards specifications

H2.0 quad output card specifications:

Connectors	4x full sized HDMI™ connectors
Resolution	up to 2x 4096x2160@60p
Color depth	8-bit; 10-bit; 12-bit (DL or lower)
Features	Rotation and splitter mode
Color sampling	up to UHD@60p 4:4:4 8-bit, or 4:2:2 10-bit
HDCP	HDCP 2.2 compliant
Signal capacity	600 MHz
Connectors*	4x full sized HDMI™ 2.0 connectors
Resolution*	Support up to 4x 4096x2160 @60Hz
Color depth*	8-bit; 10-bit; 12-bit
Color sampling*	up to UHD@60p 8-bit 4:4:4 or 10-bit 4:2:2
HDCP*	HDCP 2.2 compliant
Signal capacity*	up to 4096x2160 @60Hz
*	Specification when used with Encore3

DisplayPort1.2 quad output card specifications:

Connectors	4x full sized DisplayPort connectors
Resolution	up to 2x 4096x2160@60p
Color depth	8-bit; 10-bit; 12-bit (DL or lower)
Features	Rotation and splitter mode
Color sampling	up to UHD@60p 4:4:4 10-bit
HDCP	HDCP 1.x compliant
Signal capacity	660 MHz
Connectors*	4x full sized DisplayPort connectors
Resolution*	Support up to 4x 4096x2160 @60Hz
Color depth*	8-bit; 10-bit; 12-bit
Color sampling*	up to UHD@60p 4:4:4 10-bit
HDCP*	HDCP 1.x compliant (top two connectors)
Signal capacity*	up to 4096x2160 @60Hz
*	Specification when used with Encore3

Tri-combo output card specifications:

Connectors	1x DP 1.2; 1x HDMI™ 2.0; 4x 12G-SDI (BNC)
Resolution	up to 2x 4096x2160@60p
Color depth	8-bit; 10-bit; 12-bit (DL or lower)
Features	Rotation and splitter mode
Color sampling	HDMI™ 2.0: up to UHD@60p 4:4:4 8-bit DP1.2: up to UHD@60p 4:4:4 10-bit 12G-SDI: up to UHD@60p 4:2:2 10-bit
HDCP	HDCP 2.2 compliant on HDMI™ HDCP 1.x compliant on DisplayPort
Signal capacity	HDMI™: 600 MHz DisplayPort: 660MHz
Connectors*	1x DP 1.2; 1x HDMI™ 2.0; 4x 12G-SDI (BNC)
Resolution*	Support up to 4x 4096x2160 @60Hz
Color depth*	8-bit; 10-bit; 12-bit
Color sampling*	HDMI™ 2.0: up to UHD@60p 4:4:4 8-bit DP1.2: up to UHD@60p 4:4:4 10-bit 12G-SDI: up to UHD@60p 4:2:2 10-bit
HDCP*	HDCP 2.2 compliant on HDMI™ 2.0 HDCP 1.x compliant on DisplayPort
Signal capacity*	up to 4096x2160 @60Hz
*	Specification when used with Encore3

A.4 Link cards specifications

Link card specifications:

Connectors	4x 100G QSFP28
-------------------	----------------

A.5 Event Master controllers specifications

EC-30 specifications:

Connectivity	USB connection from Event Master Toolset host computer (OSX or Windows 7 and higher)
Dimensions (HxWxD)	105.4 x 465.6 x 321 mm (4.15 x 18.33 x 12.63 inches)
Weight	3.18 kg (7 lbs)

EC-50 specifications:

Connectivity	USB connection from Event Master Toolset, from a control computer DVI input for touchscreen monitor
Dimensions (HxWxD)	244.34 x 511.56 x 610.05 mm / 9.62 x 20.14 x 24.02 inches
Weight	12.33 kg (27.2 lbs)

Regulatory

B

B.1	Product and contact references	184
B.2	Product compliance EU	184
B.3	Product compliance UK	185
B.4	Product compliance US	185
B.5	Product compliance Turkey	185
B.6	Product compliance China	185
B.7	Product compliance Taiwan	187
B.8	Product compliance Korea	188
B.9	Trademark notice	188
B.10	Product privacy statement	188

B.1 Product and contact references

Made in information

The made in country is indicated on the product ID label on the product itself.

Production date

The month and year of production is indicated on the product ID label on the product itself.

Manufacturer address

Refer to the cover page of this manual for the manufacturer address.

Factory address

Factory: Barco NV
President Kennedypark 35, 8500 Kortrijk, Belgium

Importers contact information

To find your local importer, contact Barco directly or one of Barco's regional offices via the contact information given on Barco's web site, <https://www.barco.com>.

B.2 Product compliance EU

Disposal Information



Waste Electrical and Electronic Equipment (WEEE)

This symbol on the product indicates that, under the European Directive 2012/19/EU governing waste from electrical and electronic equipment, this product must not be disposed of with other municipal waste. Please dispose of your waste equipment by handing it over to a designated collection point for the recycling of waste electrical and electronic equipment. To prevent possible harm to the environment or human health from uncontrolled waste disposal, please separate these items from other types of waste and recycle them responsibly to promote the sustainable reuse of material resources.

For more information about recycling of this product, please contact your local city office or your municipal waste disposal service. For details, please visit the Barco website at: <https://www.barco.com/about/sustainability/waste-of-electronic-equipment-customers>

Disposal of batteries in the product



This product contains batteries covered by the Directive 2006/66/EC which must be collected and disposed of separately from municipal waste.

If the battery contains more than the specified values of lead (Pb), mercury (Hg) or cadmium (Cd), these chemical symbols will appear below the crossed-out wheeled bin symbol.

By participating in separate collection of batteries, you will help to ensure proper disposal and to prevent potential negative effects on the environment and human health.

EN55032/CISPR32 Class A MME (MultiMedia Equipment)

Warning: this equipment is compliant with Class A of CISPR 32. In a residential environment this equipment may cause radio interference.

B.3 Product compliance UK

UK Compliance



This product is fit for use in the UK.

Authorised Representative: Barco UK Ltd

Address: Building 329, Doncastle Road
Bracknell RG12 8PE, Berkshire, United Kingdom

B.4 Product compliance US

Federal Communications Commission (FCC Statement)

This equipment has been tested and found to comply with the limits for a class A digital device, pursuant to Part 15 of the FCC rules. These limits are designed to provide reasonable protection against harmful interference when the equipment is operated in a commercial environment. This equipment generates, uses, and can radiate radio frequency energy and, if not installed and used in accordance with the instruction manual, may cause harmful interference to radio communications. Operation of this equipment in a residential area may cause harmful interference, in which case the user will be responsible for correcting any interference at his own expense

Changes or modifications not expressly approved by the party responsible for compliance could void the user's authority to operate the equipment

FCC responsible: Barco Inc.
3059 Premiere Parkway Suite 400
30097 Duluth GA, United States
Tel: +1 678 475 8000

B.5 Product compliance Turkey

Turkey RoHS compliance



Türkiye Cumhuriyeti: AEEE Yönetmeliğine Uygundur.
[Republic of Turkey: In conformity with the WEEE Regulation]

B.6 Product compliance China

产品中有害物质的名称及含有信息表 (China RoHS compliance)

根据中华人民共和国《电器电子产品有害物质限制使用管理办法》规定，以下部分列出了Barco产品中可能包含的有毒和/或有害物质的名称和含量。

部件名称 Component name	有害物质 Hazardous Substances or Elements									
	铅 (Pb)	汞 (Hg)	镉 (Cd)	六价铬 (Cr ⁶⁺)	多溴联苯 (PBB)	多溴二苯醚 (PBDE)	邻苯二甲酸二正丁酯 (DBP)	邻苯二甲酸二异丁酯 (DIBP)	邻苯二甲酸丁基苄酯 (BBP)	邻苯二甲酸二(2-乙基)己酯 (DEHP)
印制电路配件 Printed Circuit Assemblies	X	○	○	○	○	○	○	○	○	○
外接电(线)缆 External cables	X	○	○	○	○	○	○	○	○	○
散热片(器) Heatsinks	○	○	○	○	○	○	○	○	○	○
底架 Chassis	○	○	○	○	○	○	○	○	○	○
电源供应器 Power Supply Unit	X	○	○	○	○	○	○	○	○	○
风扇 Fan	X	○	○	○	○	○	○	○	○	○
螺帽,螺钉(栓),螺旋(钉),垫圈,紧固件 Nuts, bolts, screws, washers, Fasteners	○	○	○	○	○	○	○	○	○	○

注1:
○: 表示该有害物质在该部件所有均质材料中的含量均不超出电器电子产品有害物质限制使用国家标准要求。
X: 表示该有害物质至少在该部件的某一均质材料中含量超出电器电子产品有害物质限制使用国家标准要求。

注2:
以上未列出的部件, 表明其有害物质含量均不超出电器电子产品有害物质限制使用国家标准要求。



GB/T 9254.1 A级ITE(信息技术设备)

警告: 在居住环境中, 运行此设备可能会造成无线电干扰。

B.7 Product compliance Taiwan

限用物質含有情況標示聲明書 (Declaration of the Presence Condition of the Restricted Substances Marking)

設備名稱： 螢幕管理系統， 型號 (型式)： Encore3 Equipment name: Screen Management System, Type designation: Encore3						
單元 Unit	限用物質及其化學符號 Restricted substances and its chemical symbols					
	鉛 Lead (Pb)	汞 Mercury (Hg)	鎘 Cadmium (Cd)	六價鉻 Hexavalent chromium (Cr ⁶⁺)	多溴聯苯 Polybrominated biphenyls (PBB)	多溴二苯醚 Polybrominated diphenyl ethers (PBDE)
印製電路板配件 Printed Circuit Assemblies	—	○	○	○	○	○
外接電 (線) 纜 External cables	—	○	○	○	○	○
散熱片 Heatsinks	○	○	○	○	○	○
機殼 Chassis	○	○	○	○	○	○
電源供應器 Power Supply Unit	—	○	○	○	○	○
風扇 Fan	—	○	○	○	○	○
螺帽, 螺釘 (栓), 螺旋 (釘), 墊圈, 緊固件 Nuts, bolts, screws, washers, fasteners	○	○	○	○	○	○
<p>備考1. “超出0.1 wt %” 及 “超出0.01 wt %” 係指限用物質之百分比含量超出百分比含量基準值。 Note 1: “Exceeding 0.1 wt %” and “exceeding 0.01 wt %” indicate that the percentage content of the restricted substance exceeds the reference percentage value of presence condition.</p> <p>備考2. “○” 係指該項限用物質之百分比含量未超出百分比含量基準值。 Note 2: “○” indicates that the percentage content of the restricted substance does not exceed the percentage of reference value of presence.</p> <p>備考3. “—” 係指該項限用物質為排除項目。 Note 3: The “—” indicates that the restricted substance corresponds to the exemption.</p>						

BSMI Taiwan Class A statement

警告使用者: 此為甲類資訊技術設備，於居住環境中使用，可能會造成射頻擾動，在此情況下，使用者會被要求採取某些適當的對策。

B.8 Product compliance Korea

KCC statement

기종별	사용자안내문
A급기기 (업무용방송통신기자재)	이 기기는 업무용 환경에서 사용할 목적으로 적합성평가를 받은 기기로서 가정용 환경에서 사용하는 경우 전파간섭의 우려가 있습니다.

한국용: KC 인증품을 구매하여 사용하세요 - 플러그: 250 V~, 12A; 전원 코드: 60227 IEC 53, 3G 1.0 mm² (2m 최대) / 60227 IEC 53, 3G 1.5 mm²; 커넥터: 250 V~, 12 A.

B.9 Trademark notice

HDMI™

The terms HDMI, HDMI High-Definition Multimedia Interface, HDMI trade dress and the HDMI Logos are trademarks or registered trademarks of HDMI Licensing Administrator, Inc.

DisplayPort™

DisplayPort™, the DisplayPort™ logo and DisplayPortHDR™ logo are trademarks owned by the Video Electronics Standards Association (VESA®) in the United States and other countries.

USB Type-C™

USB Type-C and USB-C are a registered trademarks of USB Implementers Forum

Dante™

Audinate®, the Audinate logo and Dante® are registered trademarks of Audinate Pty Ltd.

QSFP™

FS and FS logo are trademarks or registered trademarks of FS in the U.S. and other countries.



All other trademarks and registered trademarks are trademarks or registered trademarks of their respective holders. In this manual, ™ and ® marks are not specified.

B.10 Product privacy statement

About

Learn more about Barco's Product Privacy Statement:

<https://www.barco.com/en/about/trust-center/product-privacy-statement>.

Which data is captured and why

Following data⁶ is captured for general secure operation of the product.

- IP addresses
- User ID information
- Date and time information
- Mobile network information
- Network configuration information
- Device identification information
- Device operational conditions

6. Only if applicable for the product type and model.

- Device environmental conditions
- Device performance metric
- Device configuration information
 - Resolution
 - Brightness
- Device input configuration
 - Active inputs
 - Input resolution

Data retention mechanism

An administrator should modify or delete a user (upon user request, or when the user does not work for the company anymore), either via the Users feature, or via a factory reset executed as administrator.

Logs may contain user names and IP addresses and are subject to the retention policy, but cannot be deleted by the user. The user can send a request to dataprotection@barco.com.

License info

C

C.1 Open source software 192

C.1 Open source software

Open Source Software provisions

This product contains software components released under an Open Source license. A copy of the source code is available on request by contacting your Barco customer support representative.

EACH SEPARATE OPEN SOURCE SOFTWARE COMPONENT AND ANY RELATED DOCUMENTATION ARE PROVIDED "AS IS" WITHOUT EXPRESS OR IMPLIED WARRANTY INCLUDING, BUT NOT LIMITED TO, THE IMPLIED WARRANTIES OF MERCHANTABILITY AND FITNESS FOR A PARTICULAR PURPOSE. IN NO EVENT SHALL THE COPYRIGHT HOLDER OR ANY OTHER CONTRIBUTOR BE LIABLE FOR DIRECT, INCIDENTAL, SPECIAL, EXEMPLARY OR CONSEQUENTIAL DAMAGES, EVEN IF ADVISED OF THE POSSIBILITY OF SUCH DAMAGES, HOWEVER CAUSED AND ON ANY THEORY OF LIABILITY, WHETHER IN CONTRACT, STRICT LIABILITY, OR TORT (INCLUDING NEGLIGENCE OR OTHERWISE) ARISING IN ANY WAY OUT OF THE USE OF THIS OPEN SOURCE SOFTWARE. MORE INFORMATION/ DETAILS IS TO BE FOUND IN EACH SPECIFIC OPEN SOURCE LICENSE.

Copyright on each Open Source Software component belongs to the respective initial copyright holder, each additional contributor and/or their respective assignee (s), as may be identified in the respective documentation, source code, README file, or otherwise. You shall not remove or obscure or otherwise alter the respective copyrights.

You acknowledge living up to the conditions of each separate Open Source Software license.

The list of Open Source Software components used in the development of the Software can be downloaded from the Barco website via the following URL: <https://www.barco.com/en/support/docs/R5918104>

Glossary

BNC

Bayonet Neill-Concelman (BNC) is a method of connecting coaxial cables to a BNC connector using a twist lock design. This twist lock ensures that the cable and the connector are in optimal contact and are hard to dislodge by accident. It enables the transmission of serial digital video, timing signals or audio signals.

DHCP

Dynamic Host Configuration Protocol is a protocol that manages IP addresses. When a device is connected to a DHCP network, the DHCP server will assign an unused IP address to the connected device automatically. This ensures all connected devices have unique IP addresses within the same range.

DisplayPort

Digital display interface developed by the Video Electronics Standards Association (VESA). This interface is primarily used to connect a video source to a display device such as a computer monitor, though it can also be used to transmit audio, USB, and other forms of data.

genlock

Genlock syncs the first frame of each output and locks the frames to the same clock speed. This ensures that all signals are updated together.

HDMI

High-Definition Multimedia Interface (HDMI) is a compact audio / video interface for transferring uncompressed video data and compressed / uncompressed digital audio data from an HDMI-compliant device, the source device, to a compatible computer monitor, video projector, digital television, or digital audio device. HDMI is a digital replacement for existing analog video standards.

JSON

JavaScript Object Notation is a standardised way of writing commands or small programs to and from devices.

Local network

A local network is a network made up out of a combination of network switches and/or routers on site within the same IP address range.

Mix background layer

Each screen destination comes with a mix background layer that spans the entire output or wide screen. It is not possible to split the mix background layer. Content within this mix background layer can partially fill or move within this canvas. All other layers are always positioned on top of the background layer.

Mix layer

Mix layers consist out of two customisable layers. An 'A' single layer and a 'B' single layer that are linked together. Each of these layers can have their own different layout. This makes it possible to seamlessly transition between desired layouts. For example, if layer 'A' is currently in program, a new layout can be prepared in preview using layer 'B'. Transitioning between the two layers causes layer 'B' to go to program and layer 'A' becomes ready to be prepared with a new layout in preview.

MVR (multiviewer)

The MVR can combine all inputs and screen destinations into a customizable layout. Creating an overview of the incoming content and the content that is being displayed on outputs. These layouts are intended for internal personnel, but can be used for other reasons. MVRs can be viewed using Event Master Toolset or by sending the MVR to any desired screen destination.

Output layer

Output layers allow content to be restricted within one or some of the outputs making up the wide screen canvas. This content cannot be displayed on any outputs that are not part of the output layer. If any content is partially in the output layer and partially in the rest of the canvas, then only the part within the output layer will be displayed, with the rest being cut off. These layers can work in mix or split mode.

P2P

Peer-to-peer is a network connection method that links two or more devices, known as "peers", with each other. In a peer-to-peer network all devices can function as host or client depending on the situation.

QSFP28

Quad Small Form-Factor Pluggable 28 is a copper or fiber optical connection that provides up to 100Gbps connectivity in parallel. It uses four hot-pluggable fiber or copper cables to ensure high speed transmission of data for high performance devices like the Encore3.

REST API

REpresentational State Transfer Application programming interface is a protocol that allows other devices to be controlled by the Encore3 or control the Encore3 with other devices.

Scaled aux destination

Scaled aux destinations bypass the processor on the Event Master processor. The content is sent directly from the input card to the output card without going through the internal processors. Each output card has its own scalar, allowing for 4K scaling capabilities.

Screen layer

Screen layers allow all content to be placed anywhere on the canvas without needing to be mindful of the output boundaries. Content that spans multiple outputs will be displayed without any seams or gaps between the content. Meaning, outputs that are placed side by side, without any bezels, will look continuous. Gaps can still be created by physically separating the outputs. These layers can work in mix or split mode.

SDI

Serial Digital Interface (SDI) is a serial link standardized by the Society of Motion Picture and Television Engineers (SMPTE). SDI transmits uncompressed digital video over a 75-ohm coaxial cable, typically within studios, and is seen as the most professional video infrastructure equipment.

ShowFile

A ShowFile is a custom file format, with extension `.tar.gz`, designed to store a configuration of an Event Master system. The ShowFile can include presets, input settings, destination screens, armed destinations, custom layouts and more. The ShowFile format allows for a partial import, to mix different settings with already existing configurations.

Single screen destination

A single screen destination is a display or a projector with a maximum 4K resolution. This single composition is then processed by the Event Master processor and displayed using one output.

Split layer

The two layers making up a mix layer can be split to work independently. When split, the layers will fade out and fade back in during transition between layouts. Any modifications to the layer while it is in program will be seen on the output in realtime.

Still images

Static graphics that are stored on the Event Masters local storage. Meaning, they will always be available once they are captured or transferred onto the unit.

System

Event Master Toolset uses systems to define which hardware is being used for a certain configuration. When creating a system, hardware is being added and linked to the system name. This allows the software to remember which hardware belongs to which configuration, even when the hardware is no longer present.

Terminal

The terminal is a command line interface that allows for direct communication between an application and the operating system. This is required to run automated scripts or commands. It is possible to follow along with what the application is doing. The information displayed can be used to identify possible problems or use as a temporary logging.

UMD

Under Monitor Display (UMD) is a user interface element for Event Master Toolset. It holds the name of the window it is attached to and a background color. The UMD is layered on top of the window and helps with identifying what that window is supposed to be. UMDs are typically only displayed within the software and not on the image. However, MVRs send the UMD with the image by default. This helps with providing context of each content window.

Wide screen destination

Wide screens are made up out of multiple single outputs with the same resolution connected using the same connector type. These larger connections allow for the creation of a continuous canvas. Content can be displayed anywhere within this continuous canvas without needing to be mindful of the hardware boundaries.

Widgets

It is possible to create custom buttons in a custom web page layout. These buttons can be given predefined functionality. Making the Event Master processor controllable from any device within the same network as the unit. These layouts are called widgets in Event Master.

Z-order

Z-order is an ordering method that determines whether an element appears in front or behind another element. This ordering makes it possible to position elements in a space without using additional processing power.

List of tools

Phillips screwdriver PH2
Torx screwdriver T20

Index

A

- About
 - Event Master Toolset 82
- Address
 - Production 184
- API control
 - Front panel 55
 - Web page 75
- Audio
 - Dante 17

B

- Backup
 - Create 58, 71
 - Make 71
 - Restore 72
- Battery
 - Disposal 184

C

- Card types 19
- Compliance 183
- Configuration
 - Auto save 93
 - Aux destination 100
 - Add 101
 - Clear 100
 - Create 101
 - Delete 100
 - New 101
 - Remove 100
 - Aux output
 - Edit 102
 - Manage 102
 - Front panel
 - Brightness 97
 - Flash 97
 - Lock 97
 - Unlock 97

- Genlock 94
- Input 103
 - Add 104
 - Clear 105
 - Create 104
 - Delete 105
 - Edit 105
 - Manage 105
 - New 104
 - Remove 105
- Multiviewer
 - Configure 107
 - Edit 107
 - Manage 107
- MVR
 - Configure 107
 - Edit 107
 - Manage 107
- Native rate 93
- Preset conflict 93
- Screen destination 100
 - Add 101
 - Clear 100
 - Create 101
 - Delete 100
 - Edit 102
 - Manage 102
 - New 101
 - Remove 100
- Source 103
 - Add 104
 - Clear 105
 - Create 104
 - Delete 105
 - Edit 105
 - Manage 105
 - New 104
 - Remove 105
- Unit
 - Factory and keep 96
 - Factory reset 96
 - Heat 97
 - ID 97

- Invalid feed 97
 - Name 95
 - NTP 99
 - Reboot 96
 - Rename 95
 - Reset 96
 - Run time 95
 - Setup 97
 - Shut down 96
 - Soft reset 96
 - Software 95
 - TCI 99
 - Temperature 97
 - Time 99
 - Tri-combo 99
 - Contact 78
 - Controller
 - About 24
 - Auto mapping 146
 - Background color 146
 - EC-30 24
 - EC-50 25
 - Introduction 24
 - Mapping
 - Add 147
 - Assign 147
 - Create 147
 - Delete 148
 - New 147
 - Remove 148
 - Text color 146
 - Touch display 165
 - Touch screen 165
 - Usage 159
 - Use 159
 - Event Master Toolset 149
 - Virtual console 146
 - Controller button
 - Assign 162
 - Color 160
 - Destination 160
 - Layer 161
 - LED 160
 - Transition 164
 - Cues
 - Action
 - Create 141
 - Delete 141
 - Manage 141
 - Test 141
 - Create 140
 - New 140
 - Schedule
 - Repeat 143
 - Startup 143
 - Time 143
 - Custom
 - EDID 109
 - Formats 109
 - HDR metadata 109
 - Resolutions 109
- D**
- Dante
 - Audio 17
 - Definitions 25
 - Diagnostics
 - About 52
 - Front panel 52
 - Hardware 52–53
 - Log files 52
 - Logs 52, 55
 - Temperature 52, 54
 - Web page 74
 - Disposal 183–184
 - Battery 184
 - Disposal compliance
 - EU 184
 - Turkey 185
- E**
- EC-30
 - Connections 43
 - EC-50
 - Connections 44
 - EMC compliance
 - China 185
 - EU 184
 - Taiwan 187
 - Encore3
 - AC input 42
 - Air flow 18
 - Backplane 16
 - Card slots 18
 - Configuration 48
 - Connections 40
 - Control 40
 - DC output 42
 - Front panel 47
 - Front Panel
 - ShowFile 58
 - Genlock 41
 - GUI 48
 - Introduction 16
 - Link 39
 - Local interface 48
 - Power 42
 - Rack mounting 37
 - Slot location 18
 - Slot purpose 18
 - System menu 48
 - Save 56
 - UI 48
 - User interface 48
 - Wake 43
 - Web page 67
 - Environment conditions 34
 - Event Master 16
 - Controller 23
 - Encore3 16
 - Event Master Toolset 81
 - About 82
 - Firewall requirements 82

- Install 82
 - Installation 83
 - PC requirements 82
 - PC spec 82
 - PC specifications 82
 - Requirements 82
 - Setup 82
 - Simulator 86
 - Version
 - 10 82
 - 9 82
 - Event Master Toolset 10
 - Category
 - Configuration 90
 - Controller 146
 - Cues 138
 - External devices 138
 - Multi viewer 112
 - MVR 112
 - Network 151
 - Programming 115
 - Settings 156
 - ShowFile 149
 - Tally 144
 - Widget 152
 - External devices
 - Add 138
 - Commands 139
 - Control 139
 - Copy 138
 - Detect 138
 - Import 138
 - Remove 138
- F**
- FCC statement 185
 - Firmware
 - Front panel 51
 - Front panel
 - Brightness 50
 - Flash 50
 - Lock 50
- G**
- General
 - Process 30
 - General considerations 12
- H**
- Hardware
 - setup 33
 - Help 76
- I**
- Important safety instructions 12
 - Importer 184
 - Info
 - Contact 78
 - Product 78
 - Information 78
 - Input card 19
 - Quad DP 1.2 19
 - Quad HDMI 2.0 19
 - Tri-combo 20
 - Instal
 - Requirements 34
 - Install 33
 - Input card 36
 - Link card 36
 - Output card 36
 - Process 31
 - Installation
 - Input card 36
 - Link card 36
 - Output card 36
 - Process 31
 - Requirements 34
 - Introduction 15
 - IP address
 - Front panel 49
 - Web page 78
 - IP settings
 - Front panel 49
 - Web page 78
- J**
- JSON 76
- K**
- KCC 188
- L**
- Life extension 169
 - Link 28
 - Link card 19, 23
 - Linked Encore3
 - Connections 110
 - Mapping 111
 - Overview 110
 - Mapping 111
 - Linked resources 25
 - Overview 26
 - Table 26
 - Log files
 - Web page 74
 - Logs
 - Front panel 55
 - LTC 17
- M**
- Maintenance program
 - Every four years 170
 - Every year 170
 - Multi viewer

- Edit 112
- Interface 112
- Preset 114
- UI 112

MVR

- Edit 112
- Interface 112
- Preset 114
- UI 112

N

Name

- Encore3 78
- System 78

Network

- IP address 151
- IP settings 151
- Manage 151

Notice on safety 12

O

Open source 192

Operator

- Password
- Default 88
- Permissions 88
- Switch 88

Orientation

- EC-30 16
- EC-50 16
- Encore3 16

OSS list 191

Output card 19

- Quad DP 1.2 21
- Quad HDMI 2.0 21
- Tri-combo 22

P

Password

- Front panel 55
- Web page 75

Preventative maintenance 169

Privacy 188

Process

- General 30
- Install 31
- Installation 31
- Overview 29
- ShowFile 30

Programming 133

- Alternative input 123
- Animate layer 131
- Apply user key 130–131
- Backup input 123
- Cues 137
- Destinations 117
- Edit layer 130
- Edit source 131
- Fallback 123

Folders

- Presets 119
- Sources 119
- User keys 119

Groups 117

- Presets 119
- Sources 119
- User keys 119

Image 121

- Capture 121

Layers

- Mix 118
- Split 118

Layouts 115

- Create 115–116
- New 115–116

Mix background

- Align 128
- Location 128
- Position 128

Mix layers 118

Modify layer 130–131

Move layer 131

Organize

- Presets 119
- Sources 119
- User keys 119

Output layers 119

PIP 118

Preset 134

- Create 134
- Recall 135

Saved scene 134

- Create 134
- Recall 135

Scene 124

- Add layer 125
- Add source 125
- Align 128
- Bring to front 129
- Clear layer 127
- Create layer 125
- Create source 125
- Delete layer 127
- Drop layer 125
- Drop source 125
- Location 128
- Mix background 126
- Position 128
- Remove layer 127
- Send to back 129
- Z-order 129

Screen layers 119

Selections 117

Split layers 118

Still 121

- Capture 121

Thumbnail 122

Transition

- Animation 136
- Cut 136

Views 115

- Create 115–116
- New 115–116

R

- Reboot 64
- Regulatory 183
- Remove
 - Input card 35
 - Link card 35
 - Output card 35
- Replace
 - Power supply 168
 - PSU 168
- Requirements
 - Environment 34
 - Humidity 34
 - Power 34
 - Temperature 34
- Reset 64
 - All 65
 - Full 65
 - Keep EDID 64
 - Keep ID 64
 - Keep IP 64
 - Keep Native Rate 64
- Resources 25
 - Overview 26
 - Single screen 27
 - Table 26
 - Wide screen 27
- RESTAPI 76
- Restore
 - Configuration 59
- RoHS 183
 - China 185
 - Taiwan 187
 - Turkey 185

S

- Safety 11
 - Servicing 13
- Security
 - Front panel 55
 - Web page 75
- Service 167
- Settings
 - Application
 - Language 156
 - Reset 156
 - Controller 157
 - Event Master Toolset
 - Language 156
 - Reset 156
 - Options 156
 - Web page 156
- ShowFile
 - Backup
 - Event Master Toolset 149
 - Front panel 58
 - Edit 150
 - Front Panel 58
 - Partial
 - Backup 150
 - Restore 150

- Process 30
- Restore
 - Event Master Toolset 150
 - Front panel 59
- Shut down 65
- Software update
 - Web page
 - Local 70
 - USB 70
- Specifications 175, 180
 - EC-30 180
 - EC-50 180
 - Encore3 176
 - Input card
 - Quad DP 177
 - Quad HDMI 177
 - Tri-combo 177
 - Output card
 - Quad DP 179
 - Quad HDMI 179
 - Tri-combo 179
- Still image
 - Export
 - Front panel 62
 - Import
 - Front panel 61
- Swap
 - Power supply 168
 - PSU 168
- System
 - Add 90
 - Adjust unit 93
 - Create 90
 - Disconnect 93
 - Link 92
 - Multiple 92
 - Select 89
 - Switch 89

T

- T-bar 165
- Tally
 - Add 144
 - Assign 145
 - Configure 144
 - Define 144
 - New 144
- Terms 25
- Test API 76
- Test pattern 57
- Tools 70
- Trademarks 188
- Transition bar 165
- Transition handle 165
- Troubleshooting 171
 - Abnormal behavior 172
 - Issue 172
- Turkey RoHS 185
- Turn off 65

U

- UI
 - About 84
 - Full screen 84
 - Multi window 84
- UK Compliance 185
- UKCA 185
- Unit health 169
- Unit ID 49
- User interface
 - About 84
 - Full screen 84
 - Multi window 84
- Users
 - Password
 - Default 88
 - Permissions 88
 - Switch 88

W

- Web page
 - Access 68
 - Configuration 68
 - GUI 68
 - UI 68
 - User interface 68
- WEEE 184–185
- Widget
 - Add 152
 - Background 153
 - Buttons 153
 - Create 152
 - Edit 153
 - Fields 153
 - Layout 153
 - New 152
 - Template 152
 - Use 155
- Widgets
 - Front panel 63
 - Web page 69



R5917615 /00 | 2025-08-28

www.barco.com