

Panasonic[®]

Operating Instructions

Included Installation Instructions

AV PROCESSOR For professional use only

Model No. **WR-AV800P**



HDMI[®]
HIGH-DEFINITION MULTIMEDIA INTERFACE

Thank you for purchasing this Panasonic product.
Please read these instructions carefully before using this product, and save this manual for future use.
Please carefully read the "Safety Precautions" (P.10) of this Manual before use.

Before Use

Preface

This product is a 1RU-sized AV processor equipped with a built-in audio signal processing unit, video signal processing unit, and power supply.

It is primarily used in lecture halls and conference rooms. When connected to a PC, it allows hybrid conference between online and in-person venues.

Key features

- This product is equipped with an AV bridge feature that combines input audio and video signals and enables input/output via USB (video is only supported as an output).
- It is equipped with signal processing features that are useful when used with the ceiling array microphone (WX-AM800P) (sold separately). You can connect up to four ceiling array microphones to one unit.
- Designed for sound reinforcement use with ceiling array microphones, this unit includes a feature that suppresses feedback by adjusting the audio output to each speaker based on the beam positions.
- Allows you to perform camera preset control for Panasonic or VISCA-compatible remote cameras based on speaker position detection information from multiple ceiling array microphones. It also supports 1.9 GHz wireless receivers, allowing camera preset control for up to 48 wireless microphones.
- When using multiple cameras, you need an external video switcher (commercially available) to control the input channel selection on the external video switcher based on the audio input from the ceiling array microphones or the 1.9 GHz wireless receiver. You can control up to eight cameras.
- It supports the Dante®*1 audio network, allowing for 16-channel audio input and 16-channel audio output. The analog audio input and output also include one stereo system (unbalanced terminals) for input and output.
- Various settings for the AV processor are made using the Microphone System Configuration Center software. A single piece of software can also be used to configure the 1.9 GHz digital wireless microphone system and the ceiling array microphone system. You can also access the Web GUI interface of Panasonic remote cameras.
- The control LAN terminal allows you to operate from external touch panel controllers (commercially available) and other devices.
- It supports both rack-mounted and tabletop installation.

*1 Audinate®, the Audinate logo, and Dante® are registered trademarks of Audinate Pty Ltd.

System overview

The AV Processor WR-AV800P is designed for use in lecture halls and conference rooms. When combined with ceiling array microphones, wireless receivers, remote cameras, and other equipment, it allows hybrid conference between online and in-person venues.

Example:

A system that combines the Ceiling Array Microphone WX-AM800P with multiple remote cameras

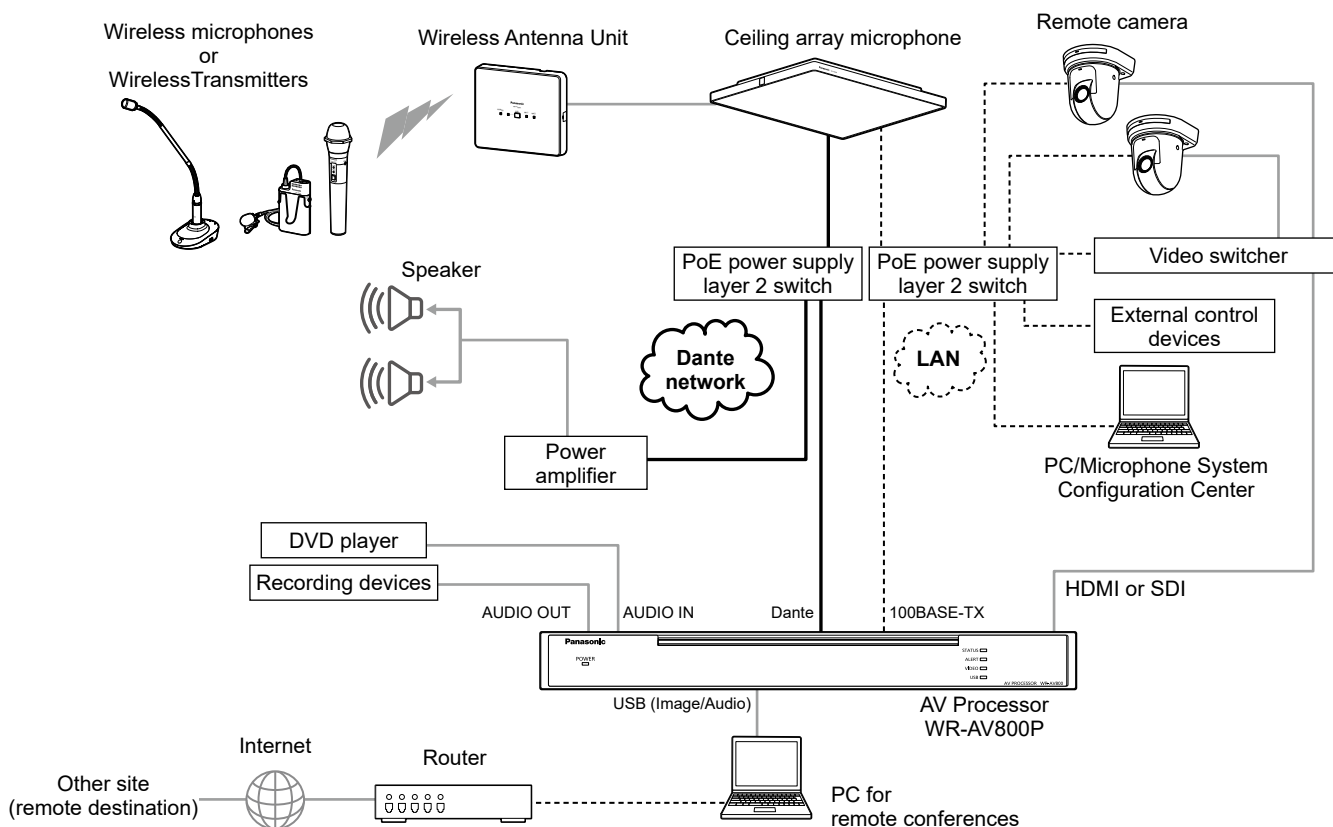

Number of ceiling array microphones that can be connected

You can connect up to four ceiling array microphones to one WR-AV800P.

Number of remote cameras that can be connected

You can connect up to eight remote cameras to one WR-AV800P.

When connecting a single remote camera, it can be connected directly to the AV processor. However, you need an external video switcher (sold separately) when using multiple remote cameras. The video switcher must be able to receive control commands through TCP/IP. For details on compatible video switchers, please visit our website.

Before Use

Example:

A system that combines a wireless receiver (WX-SR202DNP, WX-SR204DNP) and a single remote camera

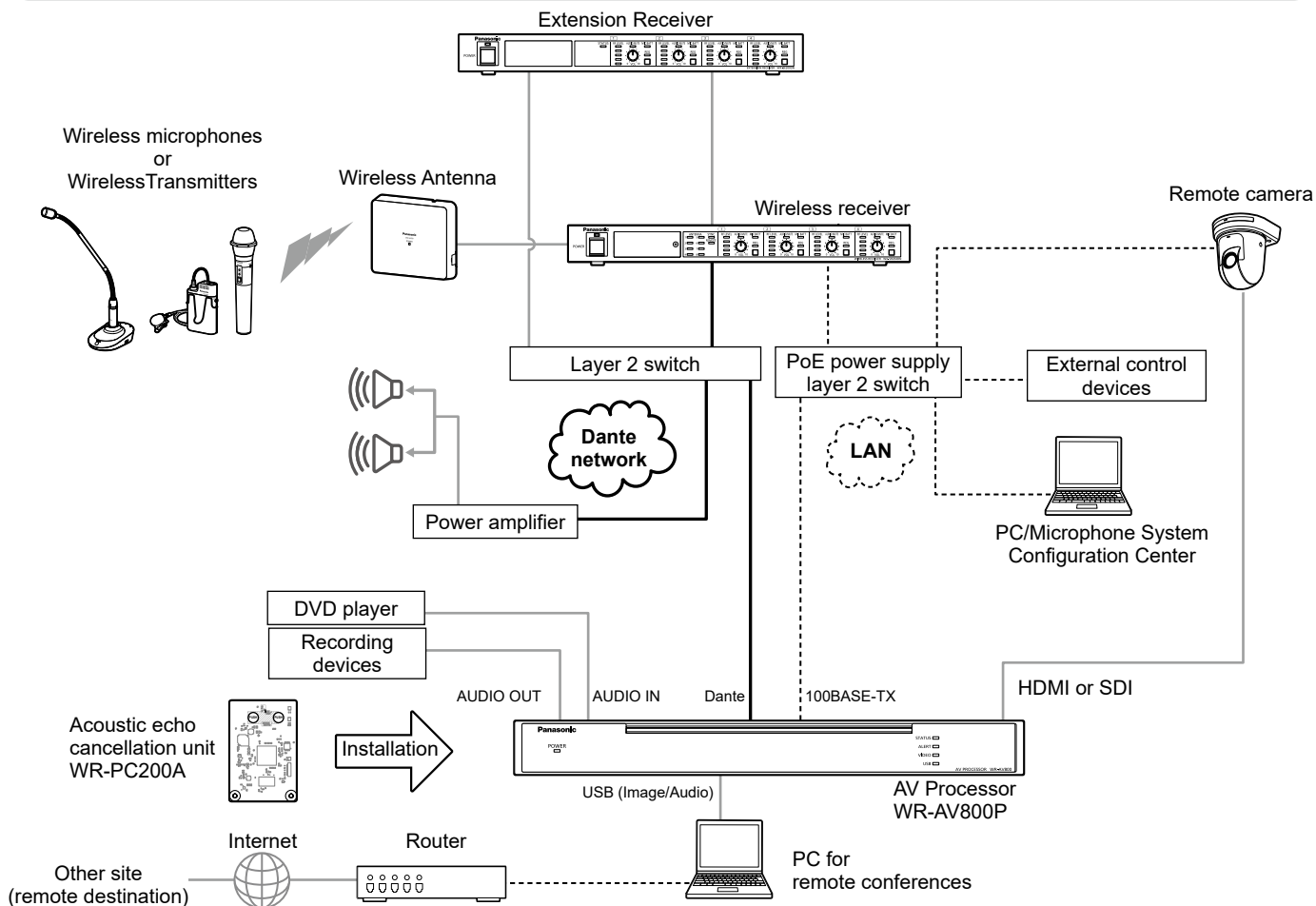

When sending audio input from a wireless receiver to a remote location, you can use the Acoustic Echo Cancellation Unit WR-PC200A to effectively suppress unwanted echoes. For details, refer to page 33 and the WR-PC200A Operating Instructions.

Note:

- For details on setting up, refer to the Microphone System Configuration Center (Room Section) Operating Instructions.
- For information on compatible remote cameras, please visit our website.

Setting tools

• About Microphone System Configuration Center

Various settings for this unit is configured from Microphone System Configuration Center. Microphone System Configuration Center must be installed on a PC in advance.

Note:

- To get Microphone System Configuration Center, please download from our website.

Standard accessories

Operating Instructions	1	Rack mount brackets.....	2
Warranty Card	1	Rack mount bracket mounting screws (M4 × 10 mm).....	4
Power cable (2 m)	1	Rubber feet.....	4
Power cable clamp	1		
Connector-type terminal block headers (3-pin)	2		

About the Operating Instructions

The operating instructions for this product are structured as shown below.

WR-AV800P Operating Instructions (Installation Guide) (Included with this product)

WR-AV800P Operating Instructions (this manual)

Microphone System Configuration Center Operating Instructions (Available for download from our website)

The operating instructions for the Microphone System Configuration Center are divided into three parts.

- Common section/1.9 GHz Digital Wireless Microphone System section
- Room section
- Conference mode

For details on installing the Microphone System Configuration Center and making the initial settings, refer to the Mic CC Operating Instructions Common section and 1.9 GHz Digital Wireless Microphone System section.

For details on performing operations from the Microphone System Configuration Center to use the AV processor, ceiling array microphone, and wireless unit, refer to the Mic CC Operating Instructions Room section.

Disclaimer of warranty

IN NO EVENT SHALL Panasonic Entertainment & Communication Co., Ltd. BE LIABLE TO ANY PARTY OR ANY PERSON, EXCEPT FOR REPLACEMENT OR REASONABLE MAINTENANCE OF THE PRODUCT, FOR THE CASES, INCLUDING BUT NOT LIMITED TO THE BELOW:

- (1) ANY LOSS OR DAMAGE, INCLUDING WITHOUT LIMITATION, DIRECT OR INDIRECT, SPECIAL, CONSEQUENTIAL OR EXEMPLARY, ARISING OUT OF OR RELATING TO THE PRODUCT;
- (2) ANY INCONVENIENCE, LOSS, OR DAMAGE CAUSED BY INAPPROPRIATE USE OR NEGLIGENT OPERATION OF THE USER;
- (3) ALL MALFUNCTIONS OR TROUBLES FROM UNAUTHORIZED DISASSEMBLE, REPAIR OR MODIFICATION OF THE PRODUCT BY THE USER, REGARDLESS OF THE CAUSE OF THE MALFUNCTION OR TROUBLE;
- (4) ANY PROBLEM CAUSING FAILED SIGNAL TRANSMISSION RESULTING IN CONSEQUENTIAL INCONVENIENCE, LOSS OR DAMAGE, ARISING OUT OF CAUSES SUCH AS SYSTEM MALFUNCTION, FAULT, SET UP OR INSTALLATION;
- (5) ANY PROBLEM, CONSEQUENTIAL INCONVENIENCE, OR LOSS OR DAMAGE, ARISING OUT OF THE SYSTEM COMBINED BY THE DEVICES OF THIRD PARTY;
- (6) INCONVENIENCE OR DAMAGE CAUSED BY FALLS DUE TO REASONS OTHER THAN PRODUCT DEFECTS OR MALFUNCTION (INCLUDING IMPROPER INSTALLATION WORK AND DEFECTS IN THE MOUNTING SURFACE OF THE BUILDING);
- (7) LOSS OF REGISTERED DATA CAUSED BY ANY FAILURE (INCLUDING INITIALIZATION OF THE PRODUCT DUE TO FORGOTTEN AUTHENTICATION INFORMATION SUCH AS A USER NAME AND PASSWORD).

Panasonic Entertainment & Communication Co., Ltd. is not responsible for accidents or damage caused by installation methods not described in the Operating Instructions or by methods that do not use the specified parts. In addition, failures occurred due to such installation will not be covered by the product warranty.

Copyright

Except for open source software licensed under GPL/LGPL and so on, distributing, copying, disassembling, reverse compiling, and reverse engineering of the software provided with this product are all expressly prohibited. In addition, exporting any software provided with this product violating export laws is prohibited.

Trademarks and registered trademarks

- Audinate®, the Audinate logo, and Dante® are registered trademarks of Audinate Pty Ltd.
- The terms HDMI, HDMI High-Definition Multimedia Interface, HDMI Trade dress and the HDMI Logos are trademarks or registered trademarks of HDMI Licensing Administrator, Inc.
- Other company names and product names in this text are trademarks or registered trademarks of their respective companies.

Open source software

Third-party software licenses included with this product

This product contains GPL/LGPL third-party software. For at least 3 years from the date of purchase, we will provide, at customer's expense, complete machine-readable source code for software licensed under GPL V2.0, LGPL V2.1, LGPL V3.0, or a license based on other conditions that meet source code disclosure requirements, along with information on the respective copyright holders, to customers who contact us at the following e-mail address.

Contact: oss-cd-request@gg.jp.panasonic.com

Alternatively, please contact us from the following website.

<https://connect.na.panasonic.com/av/audio>

The manufacturer asks users to refrain from directing inquiries concerning the source codes they have obtained and other details to its representatives.

Copyrights, etc.

Excluding the parts mentioned above, the rights to this software and other pieces of intellectual property belong to the Panasonic Entertainment & Communication Co., Ltd. or to third parties, and are not transferred to the customer.

Panasonic Entertainment & Communication Co., Ltd. does not take any responsibility for damages, losses, etc. caused by the use of this software.

Notes about networks

This product is only intended for a connection to an ethernet or PoE network without routing to the outside.

As this product works under the network connection, there is a possibility of the following occurring:

- (1) Personal information leaks through this product
- (2) Unauthorized operation of this product by ill-intentioned third parties
- (3) Disturbance or obstruction of the operation of this product by ill-intentioned third parties

In order to prevent problems such as these, it is your responsibility to take preventive security measures such as these:

- Only use the product on a safe network which is protected by a firewall, etc.
- When using this product on a system connected to a computer, regularly check said computer for, and deal with, infections from computer viruses and unauthorized programs.
- To protect against unauthorized attacks, be sure to set a password for this product with Microphone System Configuration Center.
- Apply measures, such as restricting access through authentication settings, to prevent configuration information in the product from being leaked over the network.
- Do not install the product, cables, etc., in locations where they could be easily damaged.

Abbreviations

The following abbreviations are used in this manual.

- The AV processor (WR-AV800P) is referred to as this unit.
- Microphone System Configuration Center is referred to as Mic CC.
- Personal computer is referred to as PC.
- Dante® is referred to as Dante.
- The Ceiling Array Microphone (WX-AM800P) is referred to ceiling array microphone.
- Power over Ethernet is referred to as PoE.
- A layer 2 switch that supports PoE power supply is referred to as a PoE power supply layer 2 switch.

The information about accessories described in the text is current as of June 2025. For the latest information, please contact the dealer where you purchased the product.

About this product

- This product is for professional use only.
- Descriptions of graphic symbol

 This symbol indicates an alternating current (AC).

Contents

Before Use

Installing, Connecting,
and Setting

Others

Before Use

Before Use	2
Preface	2
Key features	2
System overview	3
Setting tools	4
Standard accessories	5
About the Operating Instructions	5
Disclaimer of warranty	5
Copyright	5
Trademarks and registered trademarks	6
Open source software	6
Notes about networks	6
Abbreviations	7
About this product	7
Precautions	9
Safety precautions	10
Operating precautions	11
Part names and functions	12
Front panel	12
Rear panel	13

Installing, Connecting, and Setting

Installing and making settings	14
Installing	15
Notes on installation	15
Installing the acoustic echo cancellation unit	17
Installing the unit in a rack	19
Attaching the rubber feet	20
Attaching the power cable	21
Connecting	22
Connecting Dante®	22
About Dante®	22
About Dante Controller	22
Connecting to USB	23
Connecting to LAN	23
Connecting to remote cameras and video switchers	24
Connecting to analog audio devices	24
Wire stripping length	24
Compatible wires	25
Wiring procedure	25

Turning the power on/off	26
Turning the power on/off for this unit	26
Audio settings	27
Adding and positioning ceiling array microphones and ceiling speakers	27
Matrix assignment settings	27
Audio signal processing	28
Fine tuning for speaker output	30
Speaker operation control	30
Frequency shift	30
Camera link settings	31
Remote camera placement and settings	31
Video switcher settings	32
Camera area positioning and settings	32
Acoustic Echo canceller function	33

Others

Settings list	34
Dimensions	39
Audio block diagram	40
Troubleshooting	41
Specifications	42

Precautions

Panasonic Entertainment & Communication Co., Ltd. assumes no responsibility for injuries or property damage resulting from failures arising out of improper installation, operation inconsistent with this documentation or through use of parts other than this product, such as locally procured parts.

- Entrust building operations to a retailer.
The building operations needed to install this product require skill and experience. There is a risk of fires, electric shocks, injuries, and damage to property. Always ask a retailer to do this.
- For information about screws and other parts required for installation, refer to the corresponding section of this document.
- Tighten screws and bolts with the specified tools.
Failing to do so may cause parts to fall leading to accidents and injuries.
- Do not insert or pull the power plug with wet hands.
Failing to do so may cause electric shocks.
- Plug the power plug all the way in.
An improperly plugged power plug may lead to electric shocks, overheating, and fires.
Do not use damaged power plugs or loose power sockets.
- Avoid damaging the power cord and power plug. (by breaking them, tampering with them, bringing them near heat sources, bending them excessively, twisting them, pulling on them, placing heavy objects on them, tying them, etc.)
Using a damaged power cord or power plug may cause electric shocks, short circuits, or fires.
Entrust the repair of the power cord and power plug to a retailer.
- Regularly remove dust from the electric plug.
The insulation on a dusty plug may fail when it is subject to elements such as humidity, thus leading to fire or electric shocks.
Remove the power cord and clean it with a dry cloth.
- Do not use where there is a risk of exceeding the maximum recommended wattage for the socket or the wiring, and only use AC 120 V.
Overloading multi-outlet extension cords could result in overheating and fires.
- During a thunderstorm, do not touch the equipment or the cable.
Electric shocks can result.
- Do not perform the installation and wiring work during a thunderstorm.
It may lead to fire or electric shock.
- Directly grab the plug to remove the power cable from the socket.
Failing to do so may damage the cord and lead to fire or electric shocks.
- Do not install at places exposed to large amount of humidity and/or dust.
It may lead to fire or electric shock.
- Do not place on unstable surfaces.
Failing to do so may cause the product to fall leading to accidents and injuries.
- Do not attempt to repair or wire the product while it is turned ON.
It may lead to fire or electric shock.
- Connect the wiring correctly.
- Do not place containers full of water or other liquids on or near the product.
If wet, the product may lead to fire or electric shocks.
Immediately remove the power cord and contact the retailer.
- Do not pour liquid such as water or get it wet.
It may lead to fire or electric shock.
Immediately remove the power cord and contact the retailer.
- If the product shows any abnormality, immediately stop using it.
If the product shows abnormalities such as smoke or an unusual smell coming out of the product, or damage to its outer shell, continuing to use it may pose hazards such as the product catching on fire or falling, leading to injuries to the users or to further damage to the product itself.
Immediately remove the power cord and contact the retailer.
- Do not let foreign substances into the product.
Water or metals entering the product may lead to fires or electric shocks.
Immediately remove the power cord and contact the retailer.
- Do not attempt to disassemble or remodel the product.
It may lead to fire or electric shock.
- Unplug this apparatus when unused for long periods of time or maintenance.
It may lead to fire or electric shock.
- Unplug all cables when transporting the unit.
Failure to do so will create a tripping hazard and may lead to injury. It may also damage the cable and cause fire or electric shock.
- Do not cover the intake/exhaust vents or place anything.
Do not use the equipment on its side or upside down.
Doing so will cause the equipment to overheat, which can cause fire or damage to the equipment.
- Only use attachments/accessories specified by the manufacturer.

Safety precautions

WARNING:

- To prevent fire or electric shock hazard, do not expose this apparatus to rain or moisture.
- The apparatus should not be exposed to dripping or splashing and no objects filled with liquids, such as vases, should be placed on the apparatus.
- Apparatus shall be connected to a mains socket outlet with a protective earthing connection.

- This device complies with Part 15 of the FCC Rules. Operation is subject to the following two conditions: (1) This device may not cause harmful interference, and (2) this device must accept any interference received, including interference that may cause undesired operation.

FCC Caution:

Changes or modifications not expressly approved by the party responsible for compliance could void the user's authority to operate the equipment.

Supplier's Declaration of conformity

Trade Name: Panasonic

Model No.: WR-AV800P

Responsible Party:

Panasonic Corporation of North America

Two Riverfront Plaza, Newark, NJ 07102-5490

Support Contact: 1-800-491-9986

wirelessmicsupport@us.panasonic.com



NOTE: This equipment has been tested and found to comply with the limits for a Class A digital device, pursuant to part 15 of the FCC Rules. These limits are designed to provide reasonable protection against harmful interference when the equipment is operated in a commercial environment. This equipment generates, uses, and can radiate radio frequency energy and, if not installed and used in accordance with the instruction manual, may cause harmful interference to radio communications. Operation of this equipment in a residential area is likely to cause harmful interference in which case the user will be required to correct the interference at his own expense.

The model number and serial number of this product may be found on the surface of the unit.

You should note the model number and serial number of this unit in the space provided and retain this book as a permanent record of your purchase to aid identification in the event of theft.

Model No. _____

Serial No. _____

IMPORTANT SAFETY INSTRUCTIONS

- 1) Read these instructions.
- 2) Keep these instructions.
- 3) Heed all warnings.
- 4) Follow all instructions.
- 5) Do not use this apparatus near water.
- 6) Clean only with dry cloth.
- 7) Do not install near any heat sources such as radiators, heat registers, stoves, or other apparatus (including amplifiers) that produce heat.
- 8) Protect the power cord from being walked on or pinched particularly at plugs, convenience receptacles, and the point where they exit from the apparatus.
- 9) Only use attachments/accessories specified by the manufacturer.
- 10) Use only with the cart, stand, tripod, bracket, or table specified by the manufacturer, or sold with the apparatus. When a cart is used, use caution when moving the cart/apparatus combination to avoid injury from tip-over.
- 11) Unplug this apparatus during lightning storms or when unused for long periods of time.
- 12) Refer all servicing to qualified service personnel. Servicing is required when the apparatus has been damaged in any way, such as power-supply cord or plug is damaged, liquid has been spilled or objects have fallen into the apparatus, the apparatus has been exposed to rain or moisture, does not operate normally, or has been dropped.



Operating precautions

Other than the aforementioned "Precautions", make sure to follow the points below.

This product is a Professional equipment.

This product is designed to be used indoors.

- This product is not operable outdoors.
Do not expose this product to direct sunlight for hours and do not install the product near a heater or an air conditioner.
Otherwise, it may cause deformation, discoloration and malfunction.
Keep this product away from water and moisture.

Handle the unit carefully.

- This product uses parts that may be damaged by improper handling or storage.
- If parts are defective, please repair or replace them.

Operating temperature range

- The operating temperature range is 0 °C to 35 °C (32 °F to 95 °F). Use outside of this range may lead to failure or malfunction.

The power cable supplied is for use with this unit only.

- Do not use it with other devices. Additionally, do not use the power cable from other devices with this unit.

This unit does not have a power switch.

- To turn off the power, unplug the unit from the outlet.

When turning the power on or off.

- Be sure to turn off the power to the power amplifier and other peripheral devices that will be used for audio output before turning the unit on/off. Clicking noises may occur which may damage the speakers or peripheral devices.

When not using for long periods of time

- Unplug the power plug from the outlet.

About condensation

- Note that condensation may result in malfunction.
Condensation is more likely to occur in the following conditions.
 - When the humidity is high
 - When moving from a cold place to a hot or humid place
- If condensation occurs, leave it for about 1 to 2 hours, and then check that the condensation is gone before turning on the unit.

When connecting or disconnecting the connector

- Always lower the volume to its minimum level of this unit and enable the mute button or turn off the power amplifier's output before connecting or disconnecting the connector. Clicking noises may occur which may damage the speakers.

When using the unit

- Keep it as far away as possible from transceivers, transformers, dimmers, CRT monitors, etc. There is a risk that it will be subjected to induced noise.

Maintenance

- Turn off the power first. Failure to do so will lead to injury.
- Be sure to use a dry, soft cloth for cleaning.
- Avoid using benzene, paint thinners and other volatile substances.
- When using a chemical cloth for cleaning, read the caution provided with the chemical cloth product.

Usage precautions

- When mixing the same input signal through different paths, the phase differences introduced during signal processing may affect the sound quality.
- When adjusting or changing various parameters or switches while the signal is being input, discontinuity in the audio data may occur, which could result in audible noise.
- When setting or changing the output terminal, turn off the power to the power amplifier first.

Regarding network security

Important:

- Change your password regularly on Mic CC for added security.
-

Cooling fan

Important:

- The cooling fan inside the unit is a consumable part.
 - Replace it after approximately 50,000 hours of use. (However, this time is only a guideline for replacement and does not guarantee the lifespan of the part.)
 - Contact your dealer to request replacement.
-

Part names and functions

Front panel

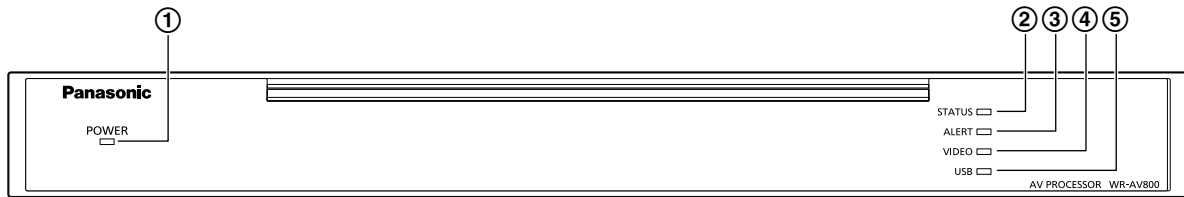

① Power indicator [POWER]

Turns on when the unit is turned on.

② Status indicator [STATUS] (green)

Displays the operation status of this unit.

Lit : Operating normally

Blinking slowly (approx. 1 second intervals)
: Starting up

Blinking quickly (approx. 0.5 second intervals)
: Performing a verification operation from
Mic CC to the specified AV processor

③ Alert indicator [ALERT] (red)

Displays the error status of this unit. If the light is on or flashing, contact your dealer.

④ Video input status indicator [VIDEO]

Displays the video signal input status of this unit.

Lit (green) : When inputting video in a supported format

Blinking slowly (approx. 1 second intervals, red)
: When inputting video in an unsupported format
In this situation, check the settings of the connected video output device.

Blinking quickly (approx. 0.5 second intervals, red)
: When there is an issue with the SDI video input signal
Check the connection status of the SDI video output device.

Off : When there is no video being input or when there is an issue with the video input signal

⑤ USB communication status indicator [USB] (green)

Displays the USB communication status of this unit.

Lit : When communication with the PC is possible

Off : When the PC is not connected or communication with the PC is not possible

Rear panel

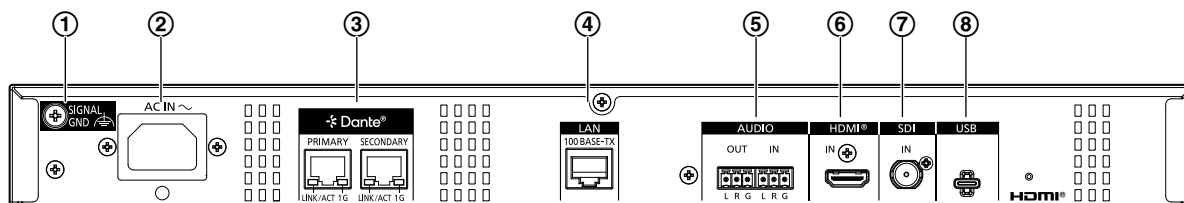

① Signal ground terminal [SIGNAL GND]

To eliminate potential differences between units, connect the SIGNAL GND for each unit.

② AC inlet [AC IN]

Connect the power cable supplied.

③ Digital audio input/output terminals [PRIMARY] [SECONDARY] (RJ45)

These terminals (RJ45) are used to connect to Dante devices using LAN cables.

④ LAN connector [100BASE-TX] (RJ45)

This terminal is used to connect to control devices such as a PC.

⑤ Stereo audio input/output terminals [AUDIO OUT, IN]

These terminals are used for unbalanced audio signal input and output. They are used to connect to the stereo output of playback devices or the stereo input of recording devices.

They can also be used as two mono input and output terminal channels for both input and output.

⑥ HDMI input terminal [HDMI IN]

This is the HDMI signal input terminal. It supports HDMI 1.4b. This unit does not support HDCP.

The HDMI IN and SDI IN terminals cannot be used simultaneously. You can select either of them from Mic CC.

⑦ SDI input terminal [SDI IN]

This is the SDI signal input terminal.

⑧ USB terminal (Type-C connector) [USB]

Connecting the unit to a PC using USB Video Class and USB Audio Class allows you to capture the unit's video/ audio output or input audio to the unit.

Installing and making settings

After installing this unit and any connected devices on-site, connect Mic CC to the network. The basic procedure for adjusting settings and installing the system, including the unit, is as follows.

Important:

- Mic CC is required for various settings of this unit, the ceiling array microphones, and the wireless receiver. Please visit our website to download Mic CC for free.
-

Note:

- Before installing this unit, you can also configure various settings for it offline. For details, refer to the Mic CC Operating Instructions (Room section).
 - For detailed instructions on setting up the ceiling array microphones and wireless receiver, refer to the operating instructions for each device, as well as the Mic CC Operating Instructions (Common section and Room section).
-

- 1** Check the audio coverage area with the ceiling array microphones, the operating range with the wireless microphone, and the area captured by the remote camera.
- 2** Determine the installation positions for the ceiling array microphones, remote camera, and ceiling speakers.
- 3** Perform the necessary wiring for power cables, LAN cables, video signal cables, audio cables, and any other necessary connections.
- 4** Turn on the power for each device and start up the necessary devices.
- 5** Start Mic CC and Dante Controller to make the various settings.
For details on Dante Controller, refer to page 22.
For details on setup procedures and making settings from Mic CC, refer to the Mic CC Operating Instructions (Common section and Room section).
 - 5.1** Create a room.
 - Set the room size and load the floor plan.
 - 5.2** Register the unit, ceiling array microphones, and wireless receiver.
 - Register the IP address and password of the unit to be set in Mic CC.
 - 5.3** Place the unit, ceiling array microphones, and wireless receiver in the room.
 - Place the unit that was registered in 5.2 in the room.
 - 5.4** Check and set the matrix settings between the input and output.
 - 5.5** Set up the routing between Dante devices using the Dante Controller.
 - 5.6** Make the audio settings for the unit.
 - You can make audio settings from Mic CC.
 - You can also make settings necessary for voice lift, such as speaker placement and registration, pre-notch settings, speaker operation settings, and frequency shift settings. For details, refer to the Mic CC Operating Instructions (Room section).
 - 5.7** Make settings for linking with remote cameras.
 - By setting the unit and remote camera in Mic CC, you can point cameras in the direction of the speaker.
 - Place, register, and make settings for remote cameras, make video switcher settings, and make camera area settings.
 - For details, refer to the Mic CC Operating Instructions (Room section).
- 6** Use the meter function and speaker output to check the input and output audio levels.
- 7** Check that the remote camera is controlled according to the position of the speaker.

Installing

Notes on installation

WARNING:

- Ask your dealer to carry out the installation work.
- Before starting the installation work, power off the devices to be connected.
- Read the “Safety precautions” section carefully and follow its instructions. Be sure to also read the instructions that came with the devices to be connected.

Ensure that the installation work complies with the technical standards governing electrical equipment.

- Before starting the installation and connection of the unit, check and prepare the necessary peripheral devices and cables. Before making connections, turn off the power to the unit, the PC, and any other connected devices.

This product is for professional use only

This unit is intended for indoor use only

- It cannot be used outdoors.
Avoid exposing the product to direct sunlight for extended periods of time, and do not install it near air conditioners or heaters. Failing to do so may lead to damage to the shape and color of the product, and may cause it to malfunction. Also avoid exposure to water droplets and bubbles.

Turn off the power when carrying out the work

- Make sure that power is not supplied to this unit before starting work. Also turn off the power to mixers and amplifiers connected to this system.
- Loud noise may be output from the speaker when connected, which may damage the device.

Concerning the installation location

- This unit generates a significant amount of heat and features a front intake fan and rear exhaust vents for cooling. Therefore, the front and rear of the unit must never be blocked.
- When installing product near a wall or ceiling, make sure it has at least 10 cm (3-15/16 inches) of clearance on all sides (see figure below).

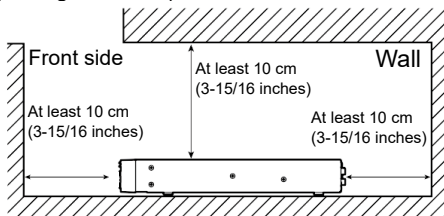

- Place the product on a flat surface. Do not place it upright with the rear surface facing downward.
- When using the unit on a table, ensure all four rubber feet are attached to the bottom to prevent scratches on the table surface.
Leave a space that is equivalent to at least the width of this unit between the unit and any heat-generating devices, such as power amplifiers or power control units.

Avoid installing in the following locations

- Locations subject to direct sunlight or near hot air outlets
- Locations where there is moisture, dust, or vibration
- Locations where a chemical agent is used such as a swimming pool
- Locations subject to significant temperature fluctuations that are prone to condensation
- Locations such as kitchens where there are high concentrations of steam and grease
- Locations near magnetic field sources such as a television or speakers
- Locations where radiation, x-rays, or strong radio waves and magnetic fields are produced
- Locations subject to salt damage or corrosive gases
- Locations exposed to water droplets or splashes
- Locations where the cables etc. could easily be damaged

Regarding the power source

- Apparatus shall be connected to a mains socket outlet with a protective earthing connection.
- The product does not have a power switch. Connect the power cord through a power breaking device in one of the following ways in order to be able to easily switch it OFF.
 - (1) Install the product near the electric outlet or breaker, and connect by the power plug.
 - (2) Connect the product to a breaker panel with at least 3.0 mm (1/8 inches) of space between contacts. Use a breaker which can cut off power from all poles except the protective ground connection.

Regarding static electricity

- To prevent damage due to static electricity, discharge any static electricity on your body by touching a metal grounding source before the installation work.

Avoid sources of noise

- Keep it as far away as possible from transceivers, transformers, dimmers, CRT monitors, etc. There is a risk that it will be subjected to induced noise.
Noise interference may occur if the cables are close to noise sources, such as power lines. In such cases, route the cables as far away as possible from the noise sources or change the location of the unit.

Regarding tightening the screws

- Make sure the screws follow the specified torque and remain straight as you tighten them. After tightening the screws, inspect them visually to make sure they are securely in place with no rattling.
- Impact screwdrivers and electric screwdrivers should not

Installing

be used because their torque is hard to control, even on models with a clutch, and they may cause damage to the mounting.

Severe impact

- Do not subject this unit to severe impact or force. There is a possibility that this unit may be damaged.

Connecting to networks

Caution:

This product is only intended for a connection to an ethernet or PoE network without routing to the outside.

Grounding

- The power cable supplied with this unit is a 3-pin type with a grounding terminal. When installing the unit, use the power cable supplied and ensure it is grounded at the outlet.
- To install this unit and perform protective grounding work, contact your dealer.

Power specifications

- The product uses AC 120 V (60 Hz) power. Connect the product to an enough capacity power source.

For unbalanced connections

- Since unbalanced connections are more susceptible to induced noise caused by differences in chassis potential, ensure that the chassis potential is the same between all devices.
- Match the power supply phase between all devices.
- Use a unified power supply system for all devices.
- Connect the ground terminals or chassis for all devices.

Equipment classification and power source indication label

Refer to the indication label on the side of this unit for the equipment classification, power supply, and other information.

For information about screws and other parts required for installation, refer to the corresponding section of this document.

Installing the acoustic echo cancellation unit

By incorporating the Acoustic Echo Cancellation Unit WR-PC200A into this unit, you can use the acoustic echo canceller function to suppress echoes that occur during web conferences and similar activities. The WR-PC200A also has a digital noise reduction function to eliminate constant noise and an auto-gain controller function to automatically correct volume fluctuations caused by acoustic echo cancellation processing.

For details, refer to page 33 in this manual and the Mic CC Operating Instructions.

Important:

- Installation requires technical skills and experience. Contact your dealer to install the acoustic echo cancellation unit.

Note:

- Always unplug the power cable from the outlet before performing any work.
- Static electricity can accumulate on clothing and the human body, so before starting work, discharge any static by touching a metal object (such as a rack).
- When removing the acoustic echo cancellation unit from the bag, hold both ends of the printed circuit board without touching the electronic components.
- Also, read the Operating Instructions for the Acoustic Echo Cancellation Unit WR-PC200A carefully.

1 Remove the top cover.

Remove the six screws from the top cover, and then remove the top cover.

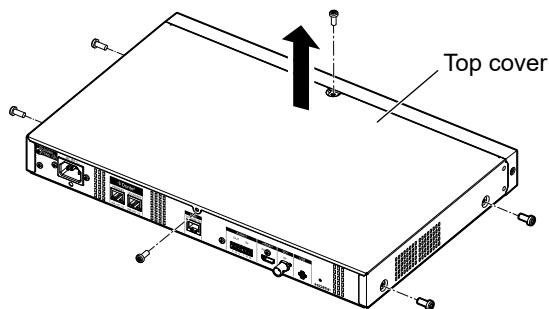

2 Remove the screws.

Remove the two screws at the point where the acoustic echo cancellation unit will be installed.

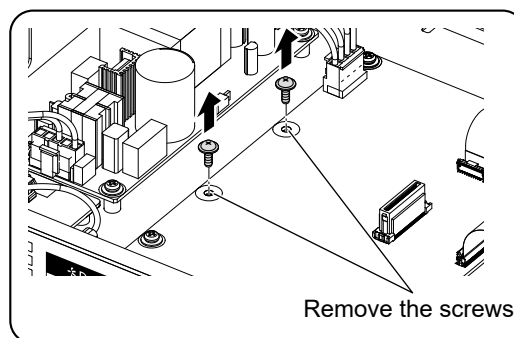

3 Install the studs.

Install the two studs (included with the WR-PC200A) at the points where the screws were removed to install the acoustic echo cancellation unit.

- Use a 5.5 mm hex screwdriver
- Screw tightening torque: 0.78 N·m {8.0 kgf·cm}

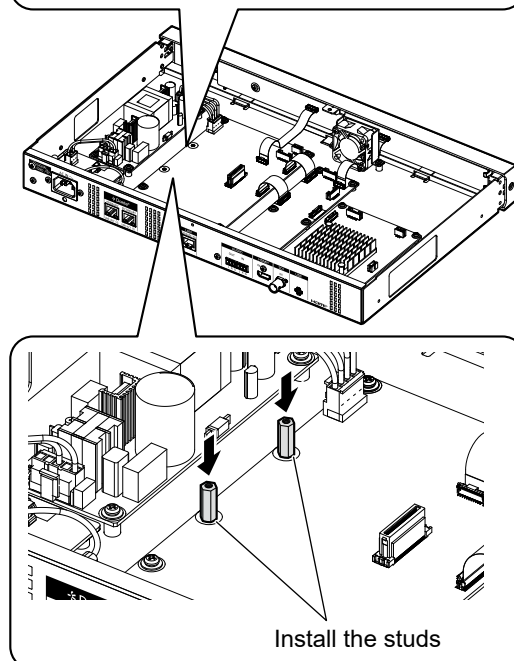

Installing

4 Mount the circuit board.

Align the circuit board horizontally with the white line indicating the acoustic echo cancellation unit's position on this unit, and then push it straight in so that the multi-pin connectors on this unit and the acoustic echo cancellation unit are connected.

- Do not push the circuit board in at an angle; ensure it is inserted straight. If the connector connections are not fully inserted and are tilted or raised, the connector may be damaged.
- Press the two points labeled "PUSH" on the acoustic echo cancellation unit to firmly push the circuit board all the way in.

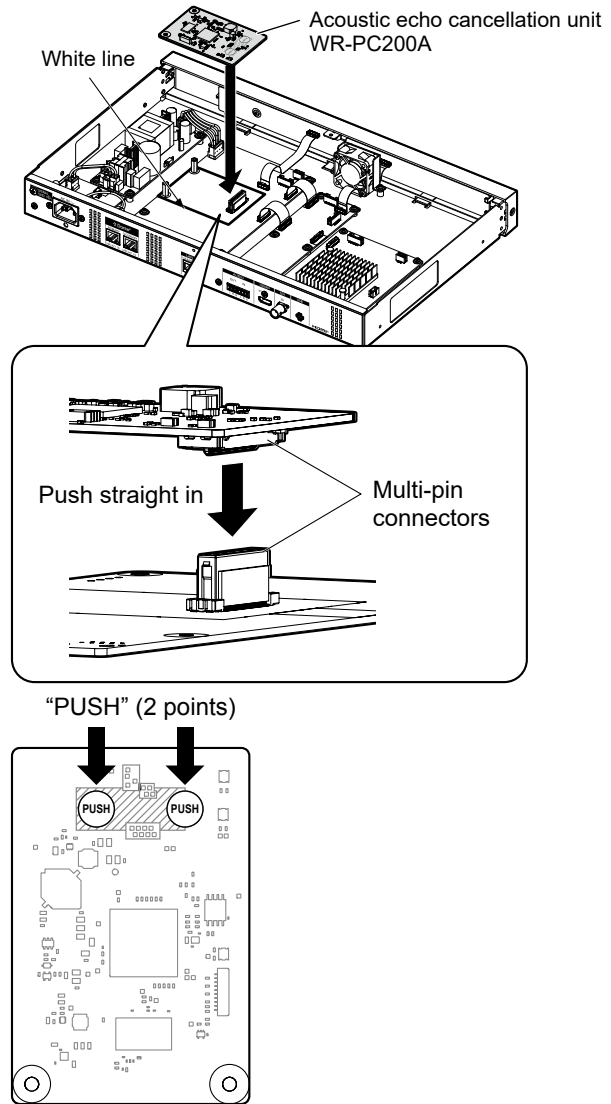

5 Secure with screws.

Using the screws removed in step 2, secure the acoustic echo cancellation unit to the studs. Hold the circuit board in place with your hand to prevent it from rotating while tightening the screws.

- Screw tightening torque: 0.69 N·m to 0.88 N·m {7.0 kgf·cm to 9.0 kgf·cm}

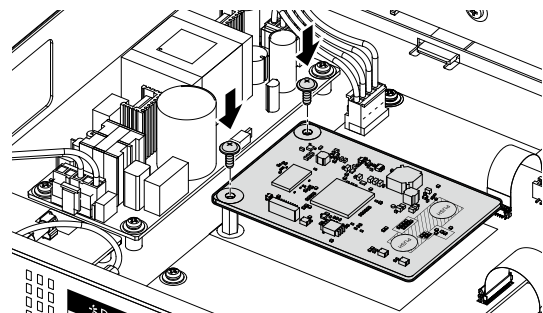

6 Reattach the top cover.

Reattach the top cover using the screws removed in step 1.

- Screw tightening torque: 0.69 N·m to 0.88 N·m {7.0 kgf·cm to 9.0 kgf·cm}

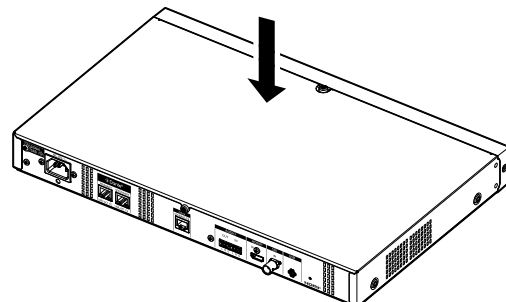

Installing the unit in a rack

Use the following racks (sold separately) to mount the unit.

EIA standard equivalent: EIA 19-inch type, with a depth of 450 mm (17-5/8 inches) or more

1 Attach the rack mounting brackets supplied to both sides of the unit using the four rack mounting bracket screws supplied (M4 x 10 mm).

- Rack mounting bracket screws tightening torque: 0.88 N·m to 1.08 N·m {9.0 kgf·cm to 11.0 kgf·cm}

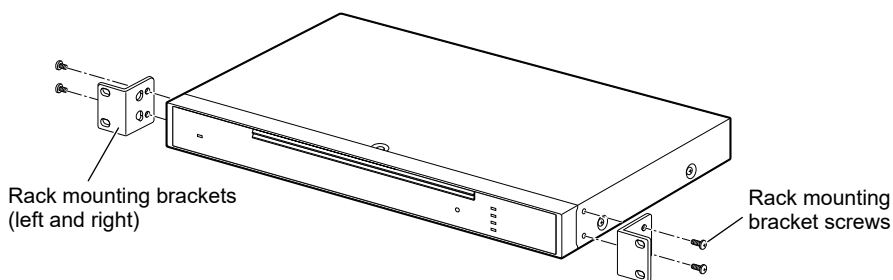

2 Install the unit in the rack.

Secure the unit to the rack using the two rack mounting screws.

- Rack mounting screw tightening torque: 2.0 N·m to 2.4 N·m {20.5 kgf·cm to 24.5 kgf·cm}

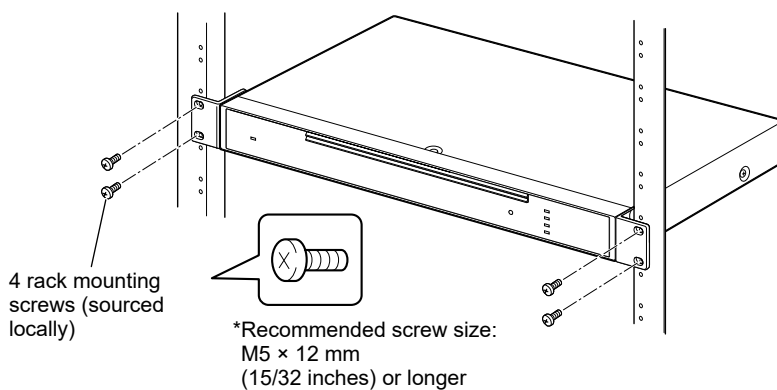

Important:

- We shall not be liable for any accidents that occur if the unit falls or tips over due to improper installation methods, other than those caused by defects in the unit itself. Exercise caution when designing the installation location and method. If the rack is not strong enough, reinforce the installation area and ensure safety before proceeding with the installation.
- For safety, ensure sufficient measures are taken to prevent falling or tipping over, and perform regular maintenance and inspections.
- For embedded installation, ensure that the internal temperature does not exceed 35 °C.
- During installation, do not block the vents on the rear panel.

Installing

Attaching the rubber feet

When using the unit on a table, attach the four rubber feet supplied (accessories) to the bottom of the unit, aligning them with the placement marks, to prevent scratches on the table surface.

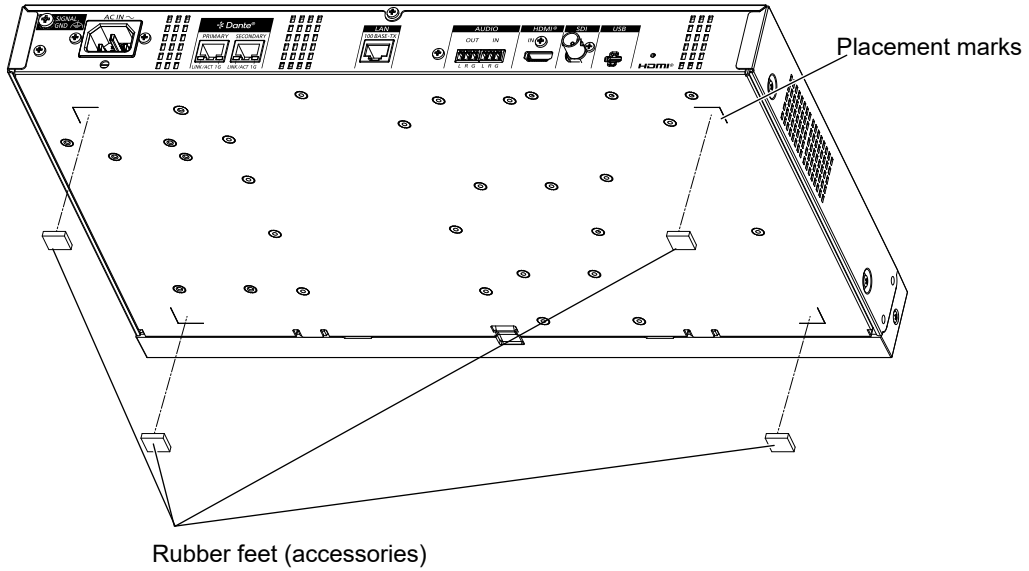

Attaching the power cable

Connect the power cable supplied to the power input terminal [AC IN] on the rear panel of the unit, and then secure the cable using the power cable clamp supplied.

Insert the power cable in the direction of the arrow as shown in the diagram below, and then secure the cable at point **(A)**.

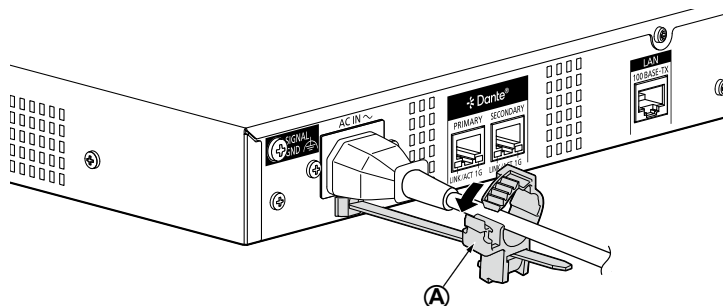

Note:

Clamping the power cable

- (1) Secure the power cable with the clamp. Tighten the belt of the power cable clamp all the way.
- (2) Slide the "Clamp" of the power cable clamp in the direction of the arrow shown in the diagram to secure the power cable's socket.
- (3) To remove the power cable clamp, operate the knob on the clamp as shown in the diagram to release it.

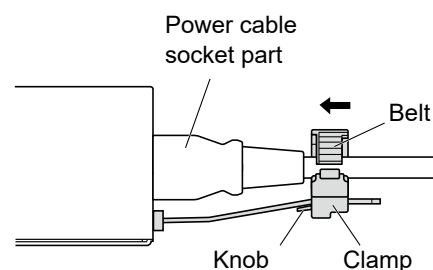

Connecting

Connecting Dante®

The unit is equipped with digital audio input and output terminals that support 16-channel input and 16-channel output audio communication using the Dante® protocol.

■ About Dante®

Dante® is a protocol developed by Audinate Pty Ltd and is designed for use in gigabit Ethernet-enabled network environments. It can simultaneously handle multiple audio signals with different sampling frequencies and bit rates, as well as control signals for devices.

For more details about Dante®, refer to the Audinate Pty Ltd website.

<http://www.audinate.com/>

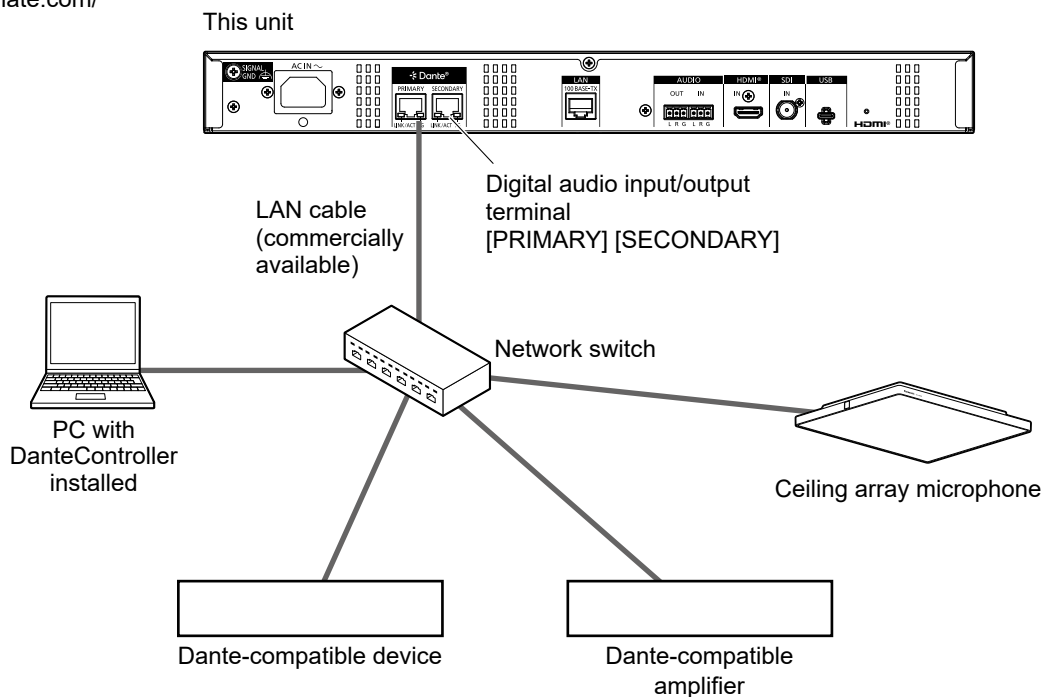

Important:

- You need a PC equipped with the Dante Controller to enable Dante connections.
- For Dante, use a separate network from the network connected to the LAN connector [100BASE-TX].
- Use a layer 2 switch with the following functions for the network switch.
 - ① Gigabit packet forwarding function
 - ② Diffserv (DSCP) QoS function with four strict priority queues
 - ③ Management functions that allow monitoring of switch settings and status
 - ④ Function to turn off EEE (Energy Efficient Ethernet) and power saving modeFor information on how to set up and operate the switch, refer to the manual for the switch.
- Use a LAN cable (commercially available) with a category rating of 5e or higher.
- The maximum length of the LAN cable (commercially available) is 100 m (328 ft).

■ About Dante Controller

Dante Controller is an application used to configure Dante® networks and routing audio. Dante Controller is used to configure complex signal paths on Dante® networks. For more details, refer to the Audinate website.

- After updating the Dante firmware or making settings in Dante Domain Manager, restart the unit.

Connecting to USB

- Connecting the unit's USB terminal to the USB terminal on an external PC allows you to perform video output and audio input/output for web conferences.
- No driver installation is required. By simply connecting to a PC, you can output video and input/output audio by USB.
- Do not use an un-powered USB extension cable.
- The maximum length of the USB cable is 4 m (13 ft). When connecting the USB cable through a converter connector, ensure that the total length is within 4 m (13 ft).

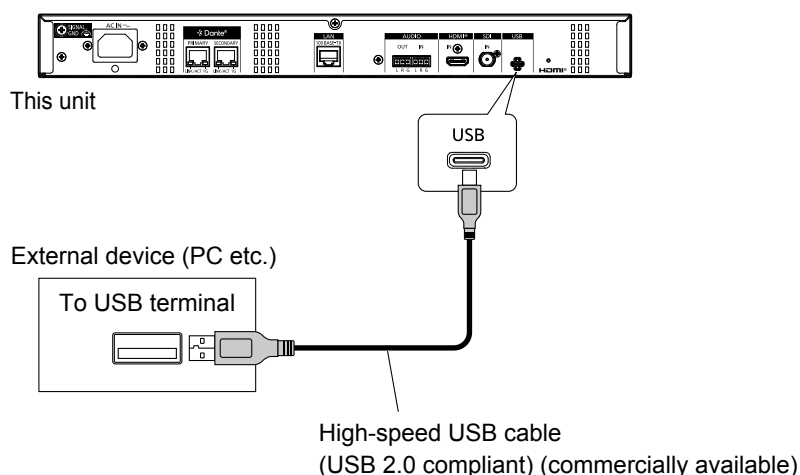

Connecting to LAN

- Connecting a PC with Mic CC installed to the unit's LAN connector [100BASE-TX] allows you to make settings for the unit, display settings, and save/load system-wide data.

This terminal can also be connected to devices such as ceiling array microphones, remote cameras and video switcher, which are used for linked control.

The following is a connection example.

- Use a LAN cable (commercially available) with a category rating of 5e or higher.
- The maximum length of the LAN cable (commercially available) is 100 m (328 ft).
- You can use straight cables or cross cables.

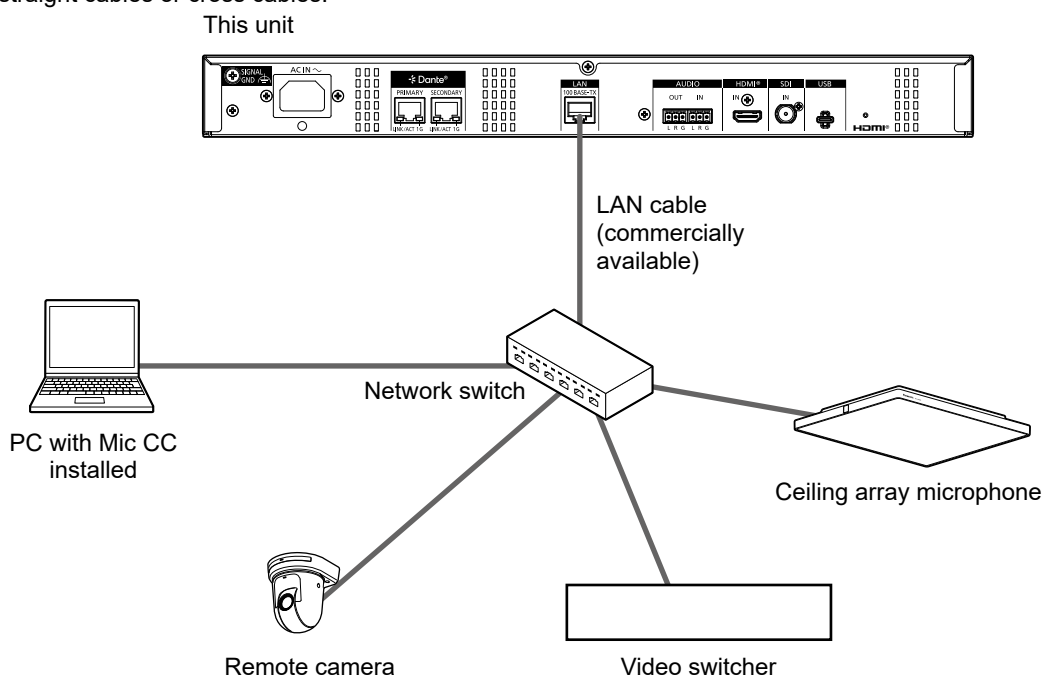

After connecting, you need to make the network settings. For details, refer to the Mic CC Operating Instructions (Room section).

Connecting

Connecting to remote cameras and video switchers

- You can input video signals to the unit by connecting the video output from a remote camera or video switcher to the HDMI or SDI input terminal.
- For the HDMI cable (sold separately), use a triple-shielded cable that supports Full HD/60P.
- Use a double-shielded cable equivalent to 5C-FB to connect the BNC cable (sold separately) to the SDI input terminal. The maximum length of the cable is 100 m (328 ft).

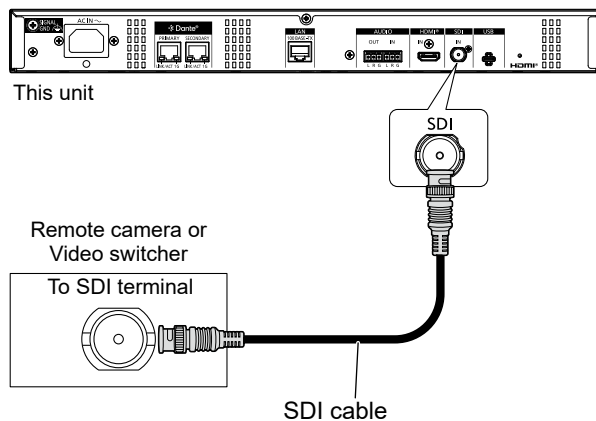
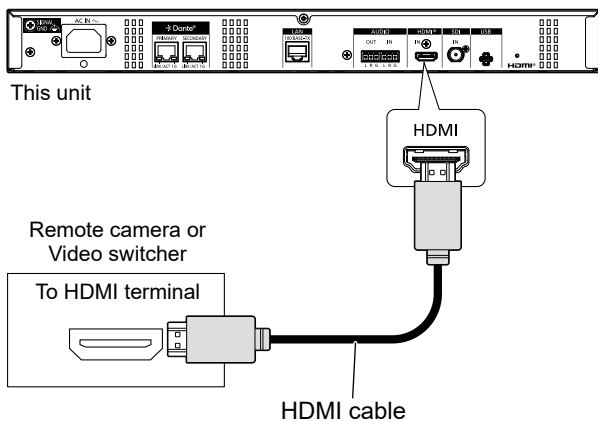

Note:

- Only one of the HDMI or SDI inputs can be used simultaneously (to be selected during installation). Switching between inputs cannot be performed during operation.

Connecting to analog audio devices

- You can connect analog audio devices to the stereo audio input/output terminals.
- The transmission method is unbalanced transmission. Unbalanced transmission is susceptible to induced noise, so the wiring distance should be within 10 m (32 ft).
- The diagram on the right shows an example of connecting to a stereo input/output device. Since two shielded wires are connected together to the header, use a dual-wire ferrule for insertion if necessary.
- The stereo audio input/output terminals use a connector-type terminal block. After connecting the wires to the included pin header, you can then connect them to the unit.
- Refer to the following for details on connecting wires to the header.

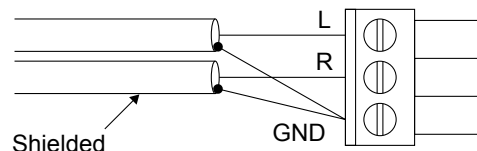

Example of cable used: Canare Electric L-2B2AT

Wire stripping length

[Solid wire, stranded wire]



[Shielded wire]

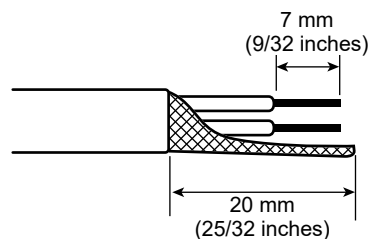

Important:

- When using stranded wire or shielded wire, do not apply solder to the stripped section. Contact failure may occur due to aging or other factors.
- When using shielded wire, if the core wire is exposed for too long from the shield, it becomes more susceptible to external noise. Use the above strip length as a guide.

Compatible wires

Stranded wire: AWG 25-16, 0.14 mm² to 1.5 mm²

Stranded wire of the same wire gauge (2): AWG 28-19, 0.08 mm² to 0.75 mm²

Wiring procedure

1. Prepare the headers (supplied with this unit).
2. Loosen the header screws and spread open the metal fittings that cover the cable insertion ports.
3. Insert the head of the striped wire into the header.
4. Tighten the screws and check that the wires are securely attached.

Screw tightening torque: 0.22 N·cm to 0.25 N·cm
{2.2 kgf·cm to 2.5 kgf·cm}

Use a flathead screwdriver with a 2.5 mm (3/32 inches) blade tip.

5. Install the header with the connected wiring into the connector.

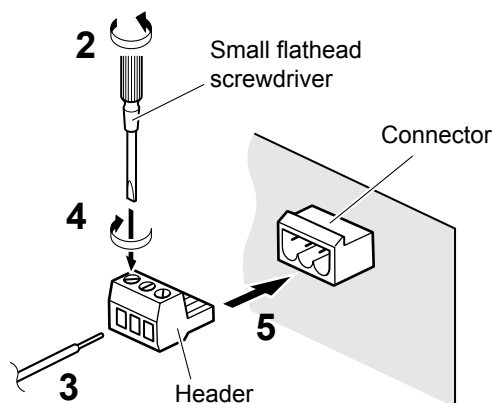

When connecting two wires to a single terminal, use a dual-wire ferrule terminal.

Model No.	Dimensions (mm)			
	d1	d2	ℓ1	ℓ2
AI-TWIN ×0.5-8WH (Manufactured by Phoenix Contact)	1.5	2.5/4.7	15.0	8.0
NFW 0.5-8 (NICHIFU)	1.5	2.4/4.6	15.0	8.0

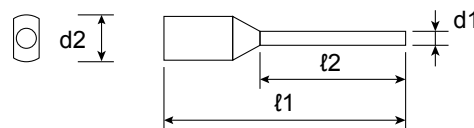

*When connecting three or more wires, bundle them together using a closed-end terminal or similar connector before connecting to the terminal block.

Turning the power on/off

Turning the power on/off for this unit

Important:

- Follow the steps below to prevent speaker damage from excessive output and injury, such as hearing damage, from sudden loud sounds.

When turning on the power, follow this sequence: Input devices → This unit → Amplifier

When turning off the power, follow this sequence: Amplifier → This unit → Input devices

- Since this unit does not have a power switch, we recommend connecting the power plug to a power control unit and operating the power control unit to turn the power on/off.
- This unit takes approximately 30 seconds from when power is supplied until startup is complete.

Audio settings

Make the audio input/output settings for the AV processor. Also, make the settings required for voice lift. Make the settings using Mic CC. For details on making settings, refer to the Mic CC Operating Instructions (Room Section).

Adding and positioning ceiling array microphones and ceiling speakers

Click the [Add unit] button in the Room window to add and position ceiling array microphones and ceiling speakers in the room. The settings for the ceiling array microphones and ceiling speakers placed here will be used later in the speaker operation control function.

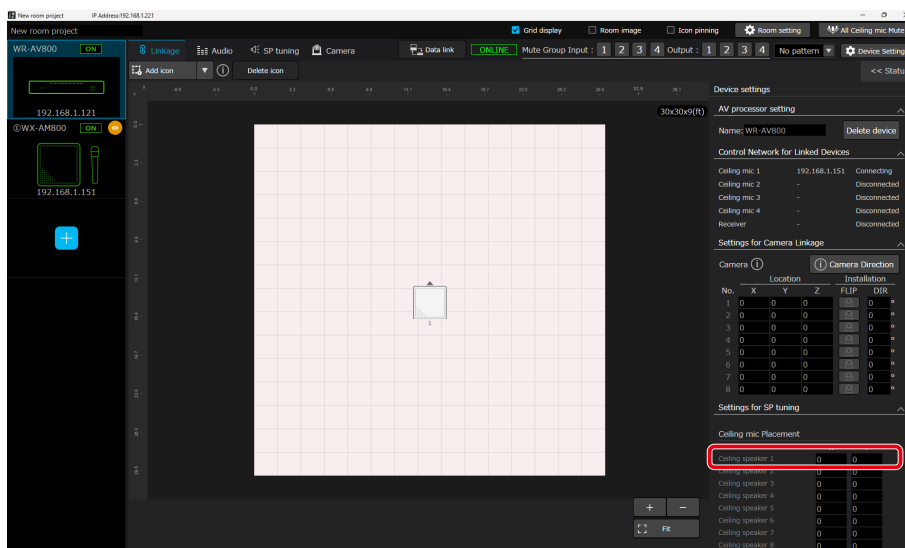

Installing, Connecting, and Setting

Matrix assignment settings

Set the Matrix assignments from the [Matrix] tab on the [Audio] tab. For each input channel, set the output channel that will send the audio. Also, set the output levels when sending the audio.

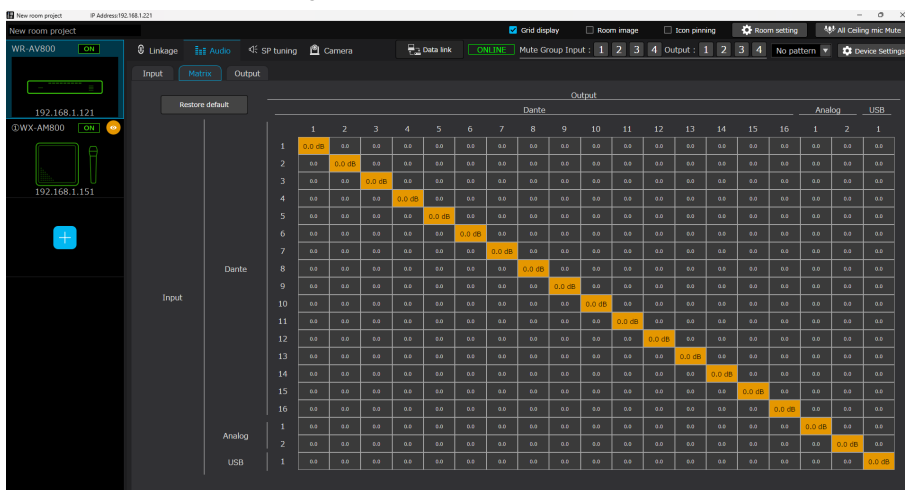

Audio settings

Audio signal processing

Set the signal processing functions built into this unit for the input and output channels.

<Input Screen (select the [Input] tab on the [Audio] tab)>

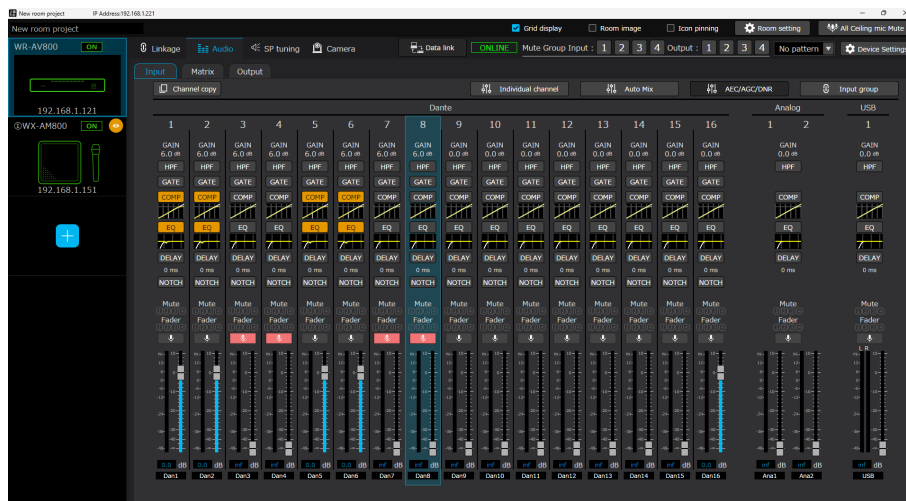

Installing, Connecting,
and Setting

<Individual Channel Screen (displayed by clicking the [Individual channel] button on the Input or Output screen)>



Level adjustment

You can adjust the levels of the audio input and output signals for this unit.

The input digital gain function allows you to adjust input audio to an appropriate volume level before performing other audio processing.

Meter function

This function displays the signal levels for the input and output signals. You can check this on the Mic CC screen.

AEC (Acoustic Echo Canceller)

This function prevents echoes by canceling audio from remote devices when the microphone picks up audio from remote locations. To use this function, WR-PC200A must be installed on this unit. Refer to page 17 for installation instructions. You can use up to 8 channels for Dante input. You can also set the reference signal.

For details about the AEC function, refer to page 33.

HPF (High Pass Filter)

By enabling this function, low-frequency noise is cut, improving clarity and making the audio easier to hear.

GATE

This function cuts audio signals when the signal level falls below a specified value, helping to suppress unwanted noise output.

COMP (Compressor)

This function makes audio signals with large volume differences easier to listen to by reducing the volume of audio signals louder than a specified level at a constant ratio.

PEQ (Parametric Equalizer)

This function adjusts the frequency characteristics of the audio. This function adjusts feedback suppression and makes audio easier to listen to.

DELAY

This function delays audio signals to adjust output timing between speakers and to synchronize audio signals with video signals.

MUTE

This function allows you to stop audio output for individual channels.

AUTO MIXER

This function automatically reduces the gain of channels with low input levels to reduce noise output by treating them as unused channels. Two systems are provided, which can be used for voice lift and remote transmission purposes.

D-NOTCH (Dynamic feedback suppressor)

This function automatically detects the frequency values of feedback that occurs during operation and automatically generates filters to suppress this feedback.

P-NOTCH (Pre-setting feedback suppressor)

This function automatically detects the frequency values of feedback that occur during installation and automatically generates filters to cut those frequencies, thereby reducing the likelihood of feedback. The generated filters are set to the PEQ of the Dante Out channels.

Mute group

This function allows you to set multiple input channels or multiple output channels as a group to mute them all together. You can set up to four groups.

Fader group

This function allows you to set multiple input channels or multiple output channels as a group to adjust their levels all together. You can set up to four groups.

Audio settings

Fine tuning for speaker output

[SP tuning] is a function for the process of picking up a speaker's voice through ceiling array microphones and outputting it from speakers to deliver uniform audio throughout the room. (This process is commonly known as "voice lift".) This enables clear audibility of speakers' voices even when they are far away.

Make the following settings to perform this.

Speaker operation control

The speaker operation control function automatically adjusts the speaker output balance based on the speaker's position to suppress feedback. The speaker output balance is adjusted by the attenuator between the Input and Output groups. The attenuation levels of the attenuator are adjusted automatically or manually, and during operation, the appropriate attenuation levels are selected based on the speaker's position information. Make the settings on the Output Tuning tab on the [SP tuning] screen.

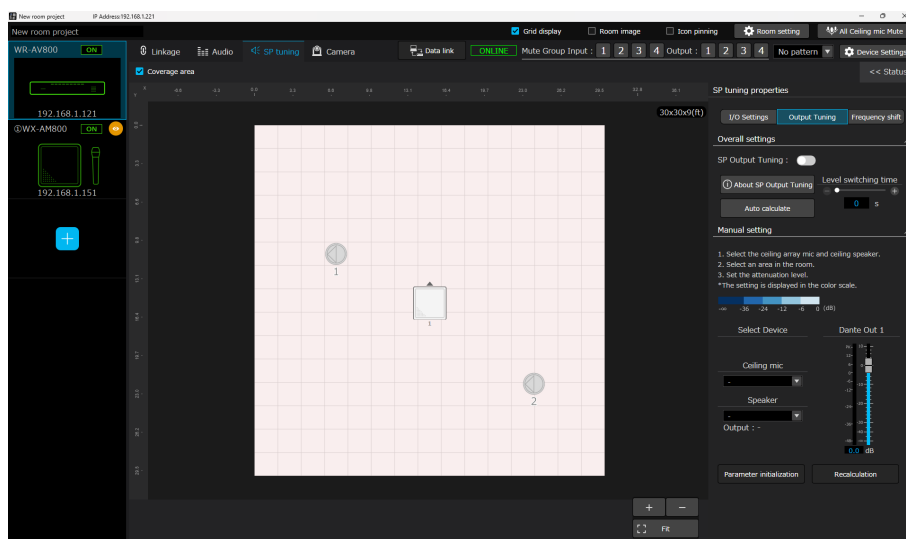

Frequency shift

This function slightly shifts the frequency of input audio when outputting to suppress feedback. This function cannot be used if the Ceiling Array Microphone WX-AM800P is not connected. Make the settings on the Frequency shift tab on the [SP tuning] screen.

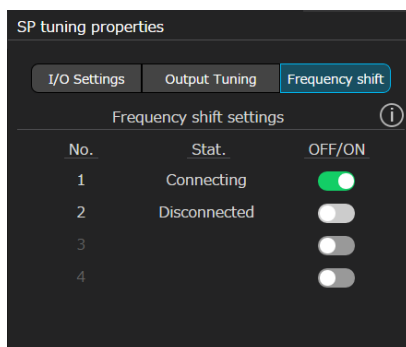

Camera link settings

- When using one or more remote cameras, you can control the pan, tilt, and zoom based on the speaker's position detected by ceiling array microphones or wireless microphones.
- When using multiple remote cameras, you can use a video switcher (sold separately) to switch between video feeds sent to remote locations. The video switcher must be able to receive control commands through TCP/IP. For details on compatible video switchers, please visit our website.
- The following two modes are available for remote camera control.
 - Preset Mode: During installation, camera presets are configured in advance for each camera area. When speech is detected within a camera area, the remote cameras are controlled according to the preset settings.
 - Beam Focus Mode: Using the detected speaker's position information, the system calculates the necessary pan, tilt, and zoom control and applies them accordingly. Therefore, you do not need to configure the presets in advance. This function is only compatible with Panasonic remote cameras.
- The number of devices that can be linked with one AV processor is as follows.
 - Ceiling array microphones: up to four
 - Remote cameras: up to eight
 - 1.9 GHz wireless microphones: up to 48** When using the Conference mode for a Panasonic 1.9 GHz digital wireless microphone system.
- When using remote cameras not provided by Panasonic, they must be compatible with VISCA over IP. For details about compatible remote cameras, please visit our website.
- For details about camera link settings, refer to the Mic CC Operating Instructions (Room Section).

Remote camera placement and settings

Position the remote cameras in the room and then make settings.

To make settings for remote cameras, launch a browser from Mic CC to display the remote camera settings screen. For details about the remote camera settings screen, refer to the operating instructions of your remote camera.

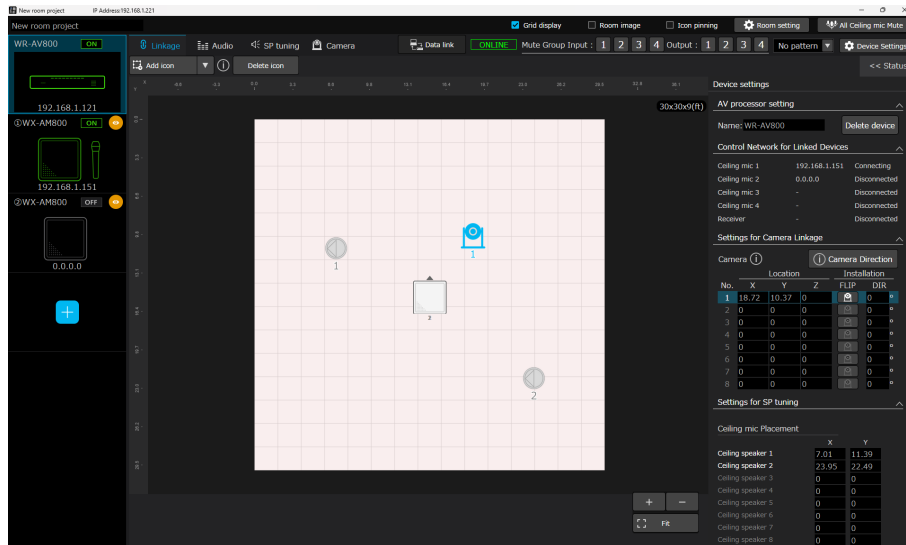

Camera link settings

Video switcher settings

Click the [Switcher settings] button on the [Camera] tab to display the Switcher settings dialog, and make video switcher settings for switching between remote camera video feeds. Make the network settings for the video switcher to be used and register the commands for calling up the video feed from each camera.

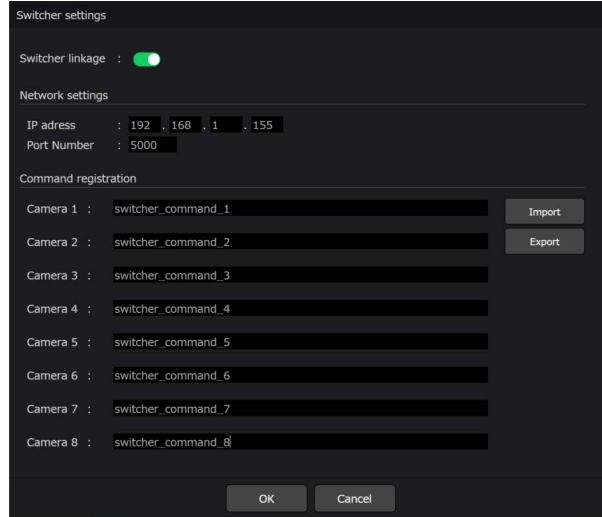

Installing, Connecting,
and Setting

Camera area positioning and settings

Select the [Camera] tab, then position and set the camera coverage areas for speaker position tracking. Set whether to use Preset Mode or Beam Focus Mode for each positioned camera area. For preset mode settings, when using Panasonic remote cameras such as AW-UE40, AW-UE50, AW-UE80 or AW-UE150A, you can enable or disable the camera's auto-tracking function for each preset. Please visit our website for details about Panasonic PTZ cameras that support this function.

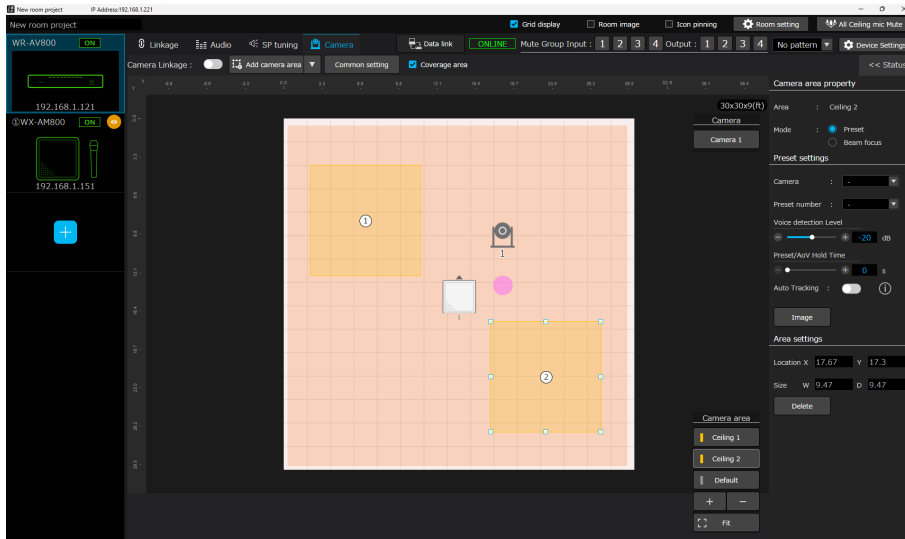

Acoustic Echo canceller function

- The AEC function is available when the Acoustic Echo Cancellation Unit (WR-PC200A: sold separately) is installed in this unit.
(AEC: Acoustic Echo Canceller)
- During two-way audio transmission between remote locations, when using microphones and speakers for sound amplification, audio from the remote location that is output through the speakers can be picked up by the microphones and returned to the remote location (as an echo). This makes it difficult for remote participants to speak because they hear their voices returning with a delay, hindering smooth communication.

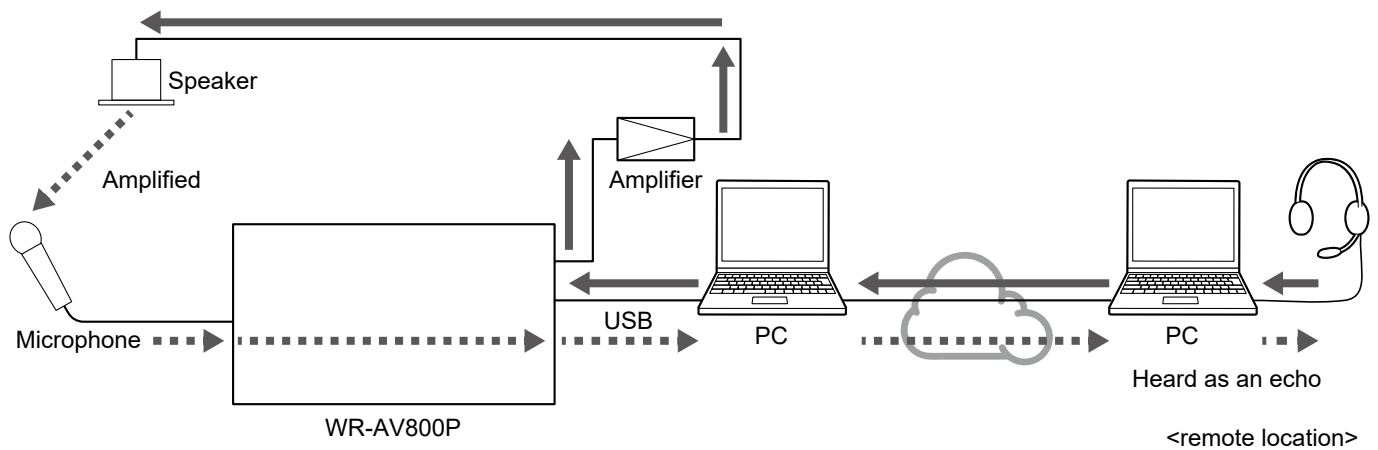

- The acoustic echo canceller function suppresses echoes by using the audio from the remote location as a reference signal and removing it from the audio sent back to the remote location. The AEC function is available when the acoustic echo cancellation unit is installed in this unit.

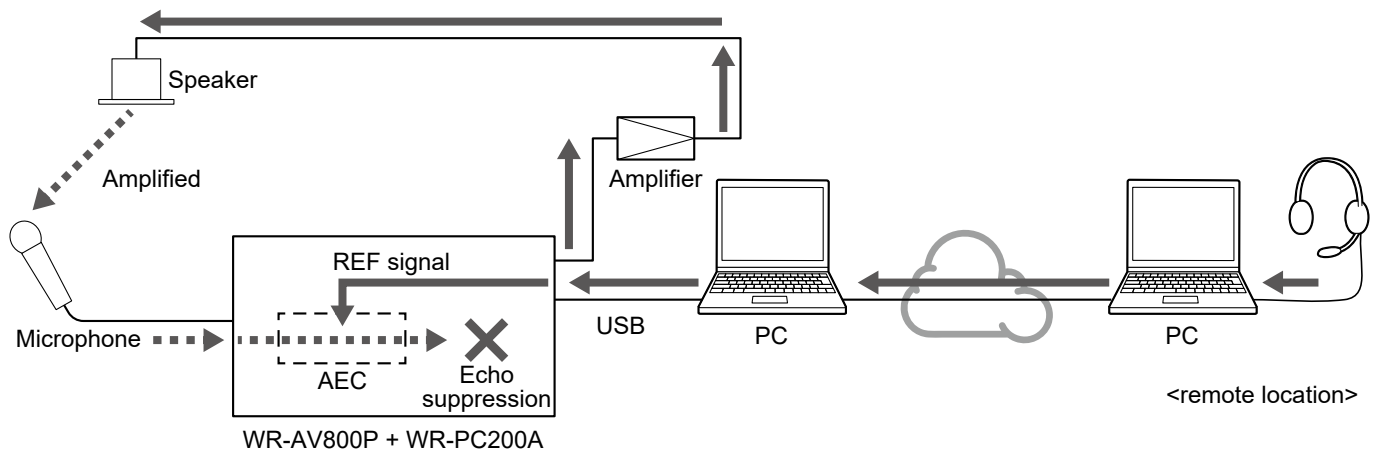

- The WR-PC200A contains eight AEC modules, as shown in the diagram on the right.
- AEC modules can be inserted into any Dante input.
- You can select up to two reference (REF) signal lines.
- It also has a digital noise reduction (DNR) function to eliminate constant noise and an auto-gain controller function to automatically correct volume fluctuations caused by acoustic echo cancellation processing, etc.
- For details about parameter settings, refer to the Mic CC Operating Instructions.

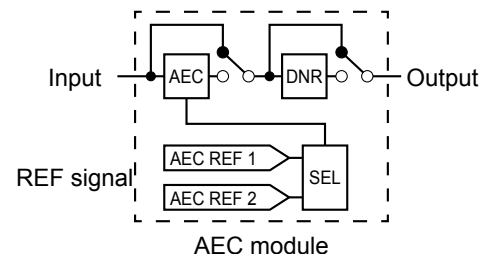

Settings list

Input channels

Item	Target Channel	Default Setting	Setting Range
Digital gain	All channels	0.0 dB	-36.0 dB to +24.0 dB (0.5 dB steps)
High pass filter	All channels	ON/OFF switch: OFF	OFF, ON
		HPF FREQ: 80 Hz	20 Hz to 1,800 Hz
Gate	Dante 1 to 16	ON/OFF switch: OFF	OFF, ON
		TH LEVEL: OFF	OFF, -70 dB to 0 dB
		ATTACK: 1 ms	0 ms to 250 ms
		RELEASE: 450 ms	5 ms to 2,000 ms
Compressor	All channels	ON/OFF switch: OFF	OFF, ON
		TH LEVEL: -8 dB	-40 dB to +20 dB
		RATIO: 4.17:1	1:1 to ∞: 1
		ATTACK: 100 ms	0 ms to 250 ms
		RELEASE: 1,000 ms	5 ms to 2,000 ms
		OUTPUT GAIN: +3.0 dB	0.0 dB to 12.0 dB
Equalizer	All channels	ON/OFF switch: ON	OFF, ON
		EQ1: FREQ: 63 Hz GAIN: 0 dB Q: 3.0	20 Hz to 20 kHz -15 dB to +15 dB (0.1 dB steps) Low-shelf, 0.3 to 30
		EQ2: FREQ: 315 Hz GAIN: 0 dB Q: 3.0	20 Hz to 20 kHz -15 dB to +15 dB (0.1 dB steps) 0.3 to 30
		EQ3: FREQ: 1.25 kHz GAIN: 0 dB Q: 3.0	20 Hz to 20 kHz -15 dB to +15 dB (0.1 dB steps) 0.3 to 30
		EQ4: FREQ: 4.00 kHz GAIN: 0 dB Q: 3.0	20 Hz to 20 kHz -15 dB to +15 dB (0.1 dB steps) High-shelf, 0.3 to 30
DELAY	All channels	ON/OFF switch: OFF	OFF, ON
		Delay time: 0 ms	0 ms to 300 ms
D-NOTCH (Dynamic feedback suppressor)	Dante 1 to 16	OFF	OFF, ON
Mute	All channels	OFF	OFF, ON
Level	All channels	-∞	-∞, -117 dB to +10 dB
Channel pair mode	Analog audio input	Stereo	Stereo, mono
Send	All channels	ON/OFF switch: OFF	OFF, ON
		Level: 0 dB	-∞, -117 dB to +10 dB

Output channels

Item	Target Channel	Default Setting	Setting Range
Equalizer	All channels	ON/OFF switch: ON	OFF, ON
	Dante 1 to 16, analog audio output	EQ1: FREQ: 63 Hz GAIN: 0 dB Q: 3.0	20 Hz to 20 kHz -15 dB to +15 dB (0.1 dB steps) Low-shelf, 0.3 to 30
		EQ2: FREQ: 125 Hz GAIN: 0 dB Q: 3.0	20 Hz to 20 kHz -15 dB to +15 dB (0.1 dB steps) 0.3 to 30
		EQ3: FREQ: 250 Hz GAIN: 0 dB Q: 3.0	20 Hz to 20 kHz -15 dB to +15 dB (0.1 dB steps) 0.3 to 30
		EQ4: FREQ: 500 Hz GAIN: 0 dB Q: 3.0	20 Hz to 20 kHz -15 dB to +15 dB (0.1 dB steps) 0.3 to 30
		EQ5: FREQ: 630 Hz GAIN: 0 dB Q: 3.0	20 Hz to 20 kHz -15 dB to +15 dB (0.1 dB steps) 0.3 to 30
		EQ6: FREQ: 2.0 kHz GAIN: 0 dB Q: 3.0	20 Hz to 20 kHz -15 dB to +15 dB (0.1 dB steps) 0.3 to 30
		EQ7: FREQ: 2.0 kHz GAIN: 0 dB Q: 3.0	20 Hz to 20 kHz -15 dB to +15 dB (0.1 dB steps) 0.3 to 30
		EQ8: FREQ: 2.0 kHz GAIN: 0 dB Q: 3.0	20 Hz to 20 kHz -15 dB to +15 dB (0.1 dB steps) 0.3 to 30
		EQ9: FREQ: 2.0 kHz GAIN: 0 dB Q: 3.0	20 Hz to 20 kHz -15 dB to +15 dB (0.1 dB steps) 0.3 to 30
		EQ10: FREQ: 2.0 kHz GAIN: 0 dB Q: 3.0	20 Hz to 20 kHz -15 dB to +15 dB (0.1 dB steps) 0.3 to 30
		EQ11: FREQ: 2.0 kHz GAIN: 0 dB Q: 3.0	20 Hz to 20 kHz -15 dB to +15 dB (0.1 dB steps) 0.3 to 30
		EQ12: FREQ: 2.0 kHz GAIN: 0 dB Q: 3.0	20 Hz to 20 kHz -15 dB to +15 dB (0.1 dB steps) High-shelf, 0.3 to 30
	USB output	EQ1: FREQ: 125 Hz GAIN: 0 dB Q: 3.0	20 Hz to 20 kHz -15 dB to +15 dB (0.1 dB steps) Low-shelf, 0.3 to 30
		EQ2: FREQ: 315 Hz GAIN: 0 dB Q: 3.0	20 Hz to 20 kHz -15 dB to +15 dB (0.1 dB steps) 0.3 to 30
		EQ3: FREQ: 1.25 kHz GAIN: 0 dB Q: 3.0	20 Hz to 20 kHz -15 dB to +15 dB (0.1 dB steps) 0.3 to 30
EQ4: FREQ: 4.00 kHz GAIN: 0 dB Q: 3.0		20 Hz to 20 kHz -15 dB to +15 dB (0.1 dB steps) High-shelf, 0.3 to 30	

Settings list

Item	Target Channel	Default Setting	Setting Range
Compressor	Dante 1 to 16, analog audio output	ON/OFF switch: OFF	OFF, ON
		TH LEVEL: -8 dB	-40 dB to +20 dB
		RATIO: 4.17:1	1:1 to ∞: 1
		ATTACK: 100 ms	0 ms to 250 ms
		RELEASE: 1,000 ms	5 ms to 2,000 ms
		OUTPUT GAIN: +3.0 dB	0.0 dB to 12.0 dB
	USB output	ON/OFF switch: ON	OFF, ON
		TH LEVEL: +2 dB	-40 dB to +20 dB
		RATIO: ∞:1	1:1 to ∞: 1
		ATTACK: 0.25 ms	0 ms to 250 ms
		RELEASE: 180 ms	5 ms to 2,000 ms
		OUTPUT GAIN: +12.0 dB	0.0 dB to 12.0 dB
DELAY	All channels	ON/OFF switch: OFF	OFF, ON
		Delay time: 0	0 ms to 300 ms 0 m to 102 m 0 feet to 334.64568 feet
Mute	All channels	OFF	OFF, ON
Level	All channels	0 dB	-∞, -117 dB to +10 dB
Channel pair mode	Analog audio output	Stereo	Stereo, mono

General audio

Item	Default Setting	Setting Range
Input channels Mute group Assign	Groups 1 to 4: Not registered	All input channels However, the same channel cannot be registered in multiple groups.
Output channels Mute group Assign	Groups 1 to 4: Not registered	All output channels However, the same channel cannot be registered in multiple groups.
Mute group ON/OFF switch	OFF	OFF, ON
Input channels Fader group Assign	Groups 1 to 4: Not registered	All input channels However, the same channel cannot be registered in multiple groups.
Output channels Fader group Assign	Groups 1 to 4: Not registered	All output channels However, the same channel cannot be registered in multiple groups.
AutoMix assign	AutoMix 1, 2: Not registered	All Dante input channels However, the same channel cannot be registered in both systems.
AutoMix ON/OFF switch	OFF	OFF, ON
SP Output Tuning ON/OFF switch	OFF	OFF, ON
SP Output Tuning Level switching time	0.0 s	0.0 to 10.0 s (0.1 s steps)

Item	Default Setting	Setting Range
Acoustic Echo Canceller (When WR-PC200A is installed)	Assign channel: OFF	OFF, Dante input 1 to 16
	REF channel number: 1	1, 2
	REF DELAY: 0 ms	0 to 135 ms (20.8 μ s steps)
	IN LEVEL: 0.0 dB	-36.0 dB to +24.0 dB (0.5 dB steps)
	REF LEVEL: 0.0 dB	-36.0 dB to +24.0 dB (0.5 dB steps)
	AUTO REF LEVEL: ON	OFF, ON
	NLP: MID	LOW, MID, HIGH
	THRU SW: OFF	OFF, ON
	AEC SW: ON	OFF, ON
	REDUCTION: -10.0 dB	-6 dB to -20 dB (0.5 dB steps)
	DNR SW: ON	OFF, ON
	AGC SW: ON	OFF, ON
REF channel selection: OFF	OFF, Dante input 1 to 16, USB input, Analog audio input 1, Analog audio input 2	
Frequency shift control for WX-AM800	ON/OFF switch: OFF	OFF, ON

General video

Item	Default Setting	Setting Range
Video input channel	HDMI	HDMI, SDI

Camera linking

Item	Default Setting	Setting Range
Voice detect start time	0.5 s	0.3 to 10.0 s Can be set separately for ceiling array microphones and wireless microphones
Voice detect stop time	1.0 s	1.0 to 10.0 s Can be set separately for ceiling array microphones and wireless microphones
Ceiling mic camera area mode	Preset mode	Preset mode, Beam Focus mode
Auto tracking ON/OFF switch	OFF	OFF, ON
Voice detection level	-10 dB	-60 dB to 60 dB (1 dB steps)
Preset/AoV Hold Time	2.0 s	0.0 to 10.0 s
Speaker Tracking Minimum Distance	0.5 m	0.00 to 10.05 m
Zoom control	DEFAULT	OFF, WIDE, DEFAULT, TELE
Switching Delay	0.0 s	0.0 to 10.0 s

Network

Item	Default Setting	Setting Range
IP mode	AUTO IP	STATIC, DHCP, AUTO IP
IP address	169.254.1.120	–
Subnet mask	255.255.0.0	–
Default gateway	0.0.0.0	–
TCP receiving port number	50003	0 to 65535
UDP transmission port number	50004	0 to 65535

Settings list

Dante (settings can only be changed using the Dante Controller)

Item	Default Setting	Setting Range
IP mode	DHCP	DHCP, STATIC
Device name	WR-AV800-"last 6 digits of Primary MAC address"	–
Channel name	Dante In 1 to 16 Dante Out 1 to 16	–

Others

Item	Default Setting	Setting Range
Pattern call at startup	Settings at Last Power-Off	Settings at Last Power-Off, Pattern Numbers 1 to 32

Audio block diagram

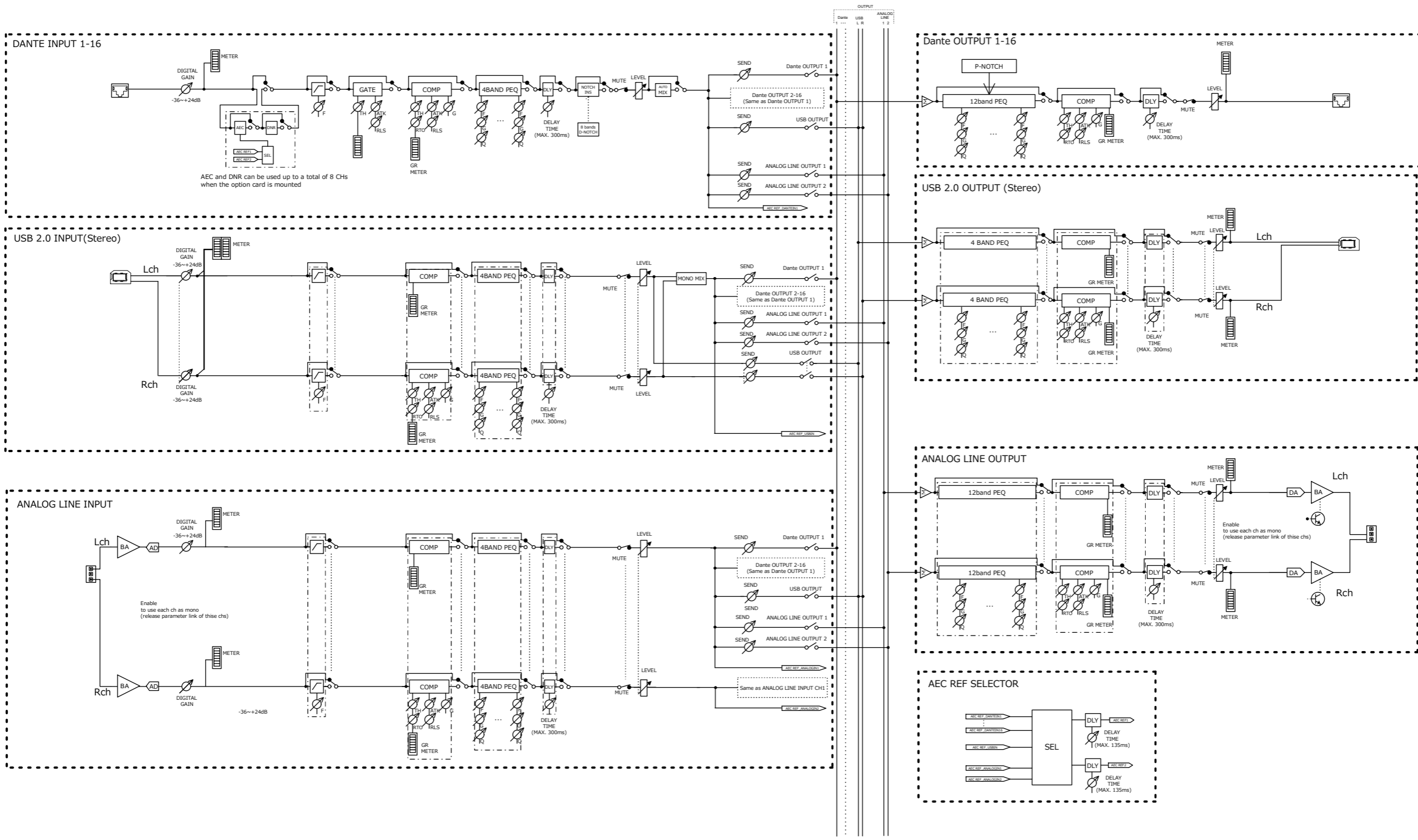

Others

Troubleshooting

Check the following before requesting repairs.

Consult your dealer if these measures do not resolve the problem, or if symptoms not listed here occur.

Symptom	Cause/Solution	Reference Pages
No audio or audio is low	<ul style="list-style-type: none"> Is the level set to the minimum? → Adjust it to an appropriate level. 	Mic CC Operating Instructions
	<ul style="list-style-type: none"> Is this unit connected to the input devices (microphones, playback devices, etc.) correctly? Is audio being output from the input device? → Connect this unit and the input devices correctly. Also, check that audio is being output from the input device. 	P.22 to 25
	<ul style="list-style-type: none"> Are the unit, amplifier, and speakers all connected correctly? → Connect them correctly. 	P.22, 24
	<ul style="list-style-type: none"> Is the amplifier volume set to minimum? → Adjust it to an appropriate level. 	—
	<ul style="list-style-type: none"> Is the signal being sent to the correct output channel? → Send the signal to the correct channel. 	Mic CC Operating Instructions
Cannot operate from Mic CC	<ul style="list-style-type: none"> Is the PC on which Mic CC is installed connected correctly? → Connect it correctly. 	P.23
	<ul style="list-style-type: none"> Is Mic CC set up correctly? → Check the Mic CC settings. 	Mic CC Operating Instructions
Power does not turn on	<ul style="list-style-type: none"> Is the power plug disconnected from the outlet? Or is the power cable disconnected from the unit? → Connect the power cable correctly. 	P.21
No video signal is output	<ul style="list-style-type: none"> Is an HDCP-protected signal being input to the HDMI input? → This unit cannot output HDCP-protected signals. 	—
If no video signal is output and the message “Input Format Error” is displayed on the USB video output, or if the video input status indicator is slowly flashing red	<ul style="list-style-type: none"> Is the video input format set to something that is not supported by the unit’s specifications? → Check the settings of the connected remote cameras and video switchers. 	—
The video input status indicator is blinking quickly red	<ul style="list-style-type: none"> When using SDI input, is the cable connected correctly, or is it damaged? → Check the SDI input connections and the condition of the cable. 	P. 24
If no video signal is output and the message “NO SIGNAL” is displayed on the USB video output, or if the video input status indicator is off	<ul style="list-style-type: none"> Is a video signal being input? → Check the cable connections and the settings of the connected remote cameras and video switchers. 	P.24
When switching input video formats, the USB output video is not displayed correctly	<ul style="list-style-type: none"> When switching input video formats, the USB output video stops briefly and then resumes output. → Depending on the software on the USB-connected PC, the connection with the AV processor may not be restored automatically. In this situation, select the output video again from the AV processor in the software. 	—
The alert indicator is lit or blinking red	<ul style="list-style-type: none"> An internal error has occurred in the unit. Immediately turn off the power and contact your dealer to request repairs. 	—

Specifications

General

Power	AC 100 to 120 V 50 Hz/60 Hz	
Power consumption	Max. 20 W	
Frequency characteristics	20 Hz to 20 kHz	
Bit depth	AD/DA 24 bit Internal signal processing resolution: 32-bit/40-bit floating point processing	
Sampling frequency	48 kHz	
Audio signal latency	Less than 1.8 ms (analog input to analog output)	
Configuration	Digital audio input	Dante input: 16 channels USB audio input: 1 stereo channel
	Digital audio output	Dante Out: 16 channels USB audio output: 1 stereo channel
	Analog audio input	Line level input: 1 stereo channel (can also be used as 2 mono channels)
	Analog audio output	Line level output: 1 stereo channel (can also be used as 2 mono channels)
	Video input	HDMI 1 channel, SDI 1 channel (selected during installation, cannot be switched during operation)
	Video output	USB 1 channel
Number of user memory slots	32	
Weight	Approx. 2.6 kg (5.7 lb)	
Operating temperature range	0° C to 35 °C (32 °F to 95 °F)	
Dimensions	420 mm (W) x 44 mm (H) x 264 mm (D) (16-9/16 inches x 1-3/4 inches x 10-3/8 inches) (excluding protruding parts such as rubber feet and knobs)	
Finish	Front panel: Black ABS resin, approximate color Munsell N1 Top cover: Black paint, approximate color Munsell N1	

Input/output specifications

Dante input/output (16 ch input, 16 ch output)	
Connector	RJ45 (Primary, Secondary)
Format	Dante
Number of flows	32
USB 2.0 terminal (audio input/output 1 stereo channel, video output 1 channel)	
Connector	Type C
USB class	USB audio class 1.0 USB video class 1.1
Video format	Format: MJPEG Video format: 1080/29.97p (for 1080/59.94p, 29.97p input), 720/59.94p (for 720/59.94p input) Signal processing: Y:Cb:Cr 4:2:2 8 bit
Audio signal bit depth	16 bit
Analog audio input (1 stereo channel)	
Connector	Connector-type terminal block (3.81 mm pitch) 3 pin
Format	Unbalanced
Input impedance	10 kΩ
Rated input level	-10 dBV
Analog audio output (1 stereo channel)	
Connector	Connector-type terminal block (3.81 mm pitch) 3 pin
Format	Unbalanced
Compatible load impedance	10 kΩ or more
Rated output level	-10 dBV
HDMI video input (1 channel)	
Connector	HDMI
Supported versions	1.4
Video format	1080/59.94p, 1080/29.97p, 720/59.94p
Others	HDCP not supported

SDI video input (1 channel)		
Connector	BNC	
Supported formats	Level A/Level B	
Signal level	0.8 V[p-p] $\pm 10\%$ (75 Ω)	
Video format	1080/59.94p, 1080/29.97p, 720/59.94p	
Others	Automatic equalizer: 100 m (when using a cable)	
Control LAN		
Connector	RJ45	
Format	100BASE-TX	

Analog audio performance

Channel-to-channel crosstalk	-70 dB or lower (@1 kHz)
Dynamic range	Analog audio input to Dante Out: 98 dB typ. (IHF-A WTD) Dante input to analog audio output: 105 dB typ. (IHF-A WTD)

Signal processing function

PEQ	PKG	Q=0.3 to 30, F=20 Hz to 20 kHz (1/48 oct steps), G= ± 15 dB (0.1 dB steps)
	Low-shelf / High-shelf	F=20 Hz to 20 kHz (1/48 oct steps), G= ± 15 dB (0.1 dB steps)
HPF	Cutoff frequency	20 Hz to 1,800 Hz (1/12 oct steps)
	Filter type	Butterworth 12 dB/oct
Gate	Threshold	-70 dB to 0 dB (0 dB= -20 dBFS, 1 dB steps)
	Attack time	0 ms to 250 ms
	Release time	5 ms to 2,000 ms
Compressor	Threshold	-40 dB to 20 dB (0 dB= -20 dBFS, 1 dB steps)
	Ratio	1:1 to ∞ : 1
	Attack time	0 ms to 250 ms
	Release time	5 ms to 2,000 ms
	Gain	0 dB to +12 dB (0.5 dB steps)
DELAY	0 ms to 300 ms (20.8 μ s steps)	
D-NOTCH (Dynamic feedback suppressor)	Equipped with Dante input 1 to 16 ch Number of notch filters per channel: 8 Notch filter characteristics: Frequency bandwidth: 40 Hz to 18 kHz (1/48 oct steps) Attenuation: 0 dB to -15 dB (3 dB steps) Q: 30, 60	
P-NOTCH (pre-setting feedback suppressor)	Can be set to Dante Out 1 to 16 ch Sets the detection results to PEQ Band 1 to 12 of the target channel Notch filter characteristics Frequency bandwidth: 40 Hz to 18 kHz (1/48 oct steps) Attenuation: 0 dB to -15 dB (3 dB steps) Q: 30, 60	
Auto mixer	Target channel: Dante input Configuration: 16 ch \times 2 groups However, the same channel cannot be set in two systems at the same time Gain sharing method	

Panasonic Entertainment & Communication Co., Ltd. assumes no responsibility for injuries or property damage resulting from failures arising out of improper installation, operation inconsistent with this documentation.

Panasonic Corporation of North America

Two Riverfront Plaza, Newark, NJ 07102-5490
<https://na.panasonic.com/us/>