

合格证
QC PASS

Godox



Godox Audio
Wechat
Official Account
神牛影音微信公众号



Overseas Official
Accounts & Updates
海外社媒平台及资讯

深圳市神牛摄影器材有限公司

地址：深圳市宝安区福海街道塘尾社区耀川工业区厂房2栋
电话：0755-29609320 (8062) 传真：0755-25723423 邮箱：godox@godox.com

GODOX Photo Equipment Co., Ltd.

Add.: Building 2, Yaochuan Industrial Zone, Tangwei Community, Fuhai Street, Bao'an District, Shenzhen 518103, China Tel: +86-755-29609320 (8062)

Fax: +86-755-25723423 Email: godox@godox.com

www.godox.com

Made in China | 705-STA000-00



SkyTalk Air

头戴式无线通话系统

Full-Duplex Wireless Intercom System

使用手册

Instruction Manual

Foreword

Thank you for purchasing!

Please read this manual carefully before using to make sure the correct operation and exert the optimum function.

Main Features

- Max. wireless transmission sight distance up to 500m.
- Environmental noise cancellation for clear intercom.
- Provides 20h long-lasting battery life.
- Adaptive expansion system enables 2 to 5-user intercom.
- Detachable lithium battery supports charging via USB-C port/charging case.
- Lightweight and comfortable wearing and flexibly adjustable head circumference.

Warning

- ▲ This product is high-precision instrument, please avoid falling, collision or pounding.
- ▲ Keep out of reach of children.
- ▲ Do not disassemble. Should repairs become necessary, this product must be sent to our Company or an authorized maintenance center.
- ▲ Always keep this product dry. Do not use in rain or damp conditions.
- ▲ Do not leave or store this product in the environment of direct sunlight, near heating devices, or in hot, humid or dusty.
- ▲ Do not leave or store the product if the ambient temperature reads over 60°C.
- ▲ Do not use in flammable and explosive environments. Pay attention to the relevant warning signs.
- ▲ Please read carefully and follow the warnings or instructions provided by the manufacturer.
- ▲ Keep small batteries that could be swallowed by children out of their reach.
- ▲ Never swallow batteries, as swallowing may cause burns. If swallowed accidentally, seek medical attention immediately.

Name of Parts

Headset

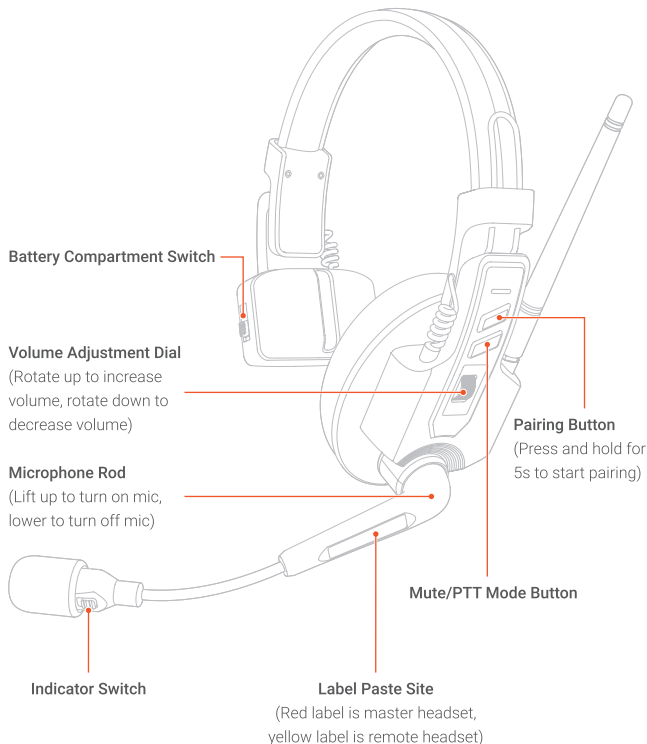

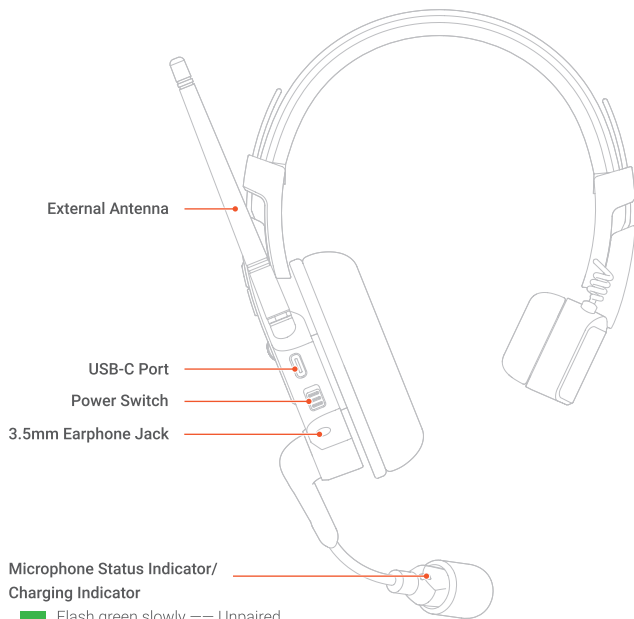

- Flash green slowly --- Unpaired
- Constant on green --- Paired
- Flash green rapidly --- Pairing
- Breathe red --- Low battery level
- Flash red and green quickly and alternately --- Searching headset within group
- Constant on red --- Mic off
- Flash blue slowly in power off status --- Charging
- Constant on blue for 5min then light off in power off status --- Fully charged
- Power it on and insert the charging cord, the indicator flashes blue slowly for 5s then enter working status.

What's Inside

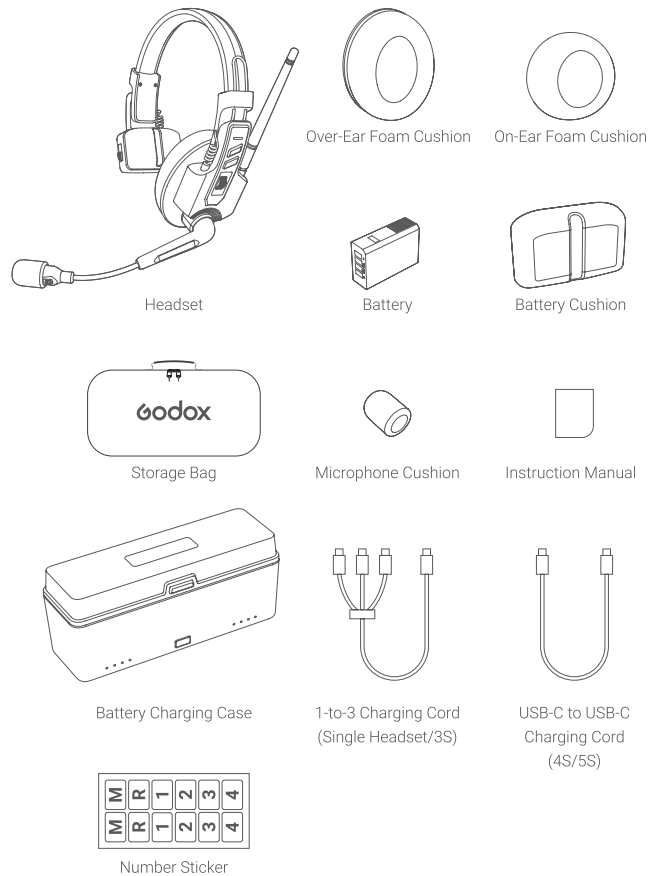

Product Name	Model	Item List		
Charging Case	STA-CH08	Charging Case x1	Charging Cord x1	Instruction Manual x1
Headset	SkyTalk Air	Headset x1 Microphone Cushion x1 Over-Ear Foam Cushion x1	Battery x1 On-Ear Foam Cushion x1 Instruction Manual x1	Charging Cord x1 Battery Cushion x1 Number Sticker x1
Full-Duplex Wireless Intercom System	SkyTalk Air 3S	Headset x3 Microphone Cushion x3 Over-Ear Foam Cushion x3 Number Sticker x1	Battery x3 On-Ear Foam Cushion x3 Storage Bag x1	Charging Cord x1 Battery Cushion x3 Instruction Manual x1
	SkyTalk Air 4S	Headset x4 Charging Case x1 Battery Cushion x4 Instruction Manual x1	Battery x4 Microphone Cushion x4 Over-Ear Foam Cushion x4 Number Sticker x1	Charging Cord x1 On-Ear Foam Cushion x4 Storage Bag x1
	SkyTalk Air 5S	Headset x5 Charging Case x1 Battery Cushion x5 Instruction Manual x1	Battery x5 Microphone Cushion x5 Over-Ear Foam Cushion x5 Number Sticker x1	Charging Cord x1 On-Ear Foam Cushion x5 Storage Bag x1

Note: Due to continuous updates and upgrades of the products, there may be differences between the actual products and the pictures. Therefore, the pictures are for reference only, products to prevail in kind.

Installing/Disassembling the Battery

Installation

Slide down the battery compartment switch and open the cover. Insert the battery into the battery compartment with the contacts facing inwards and close the cover.

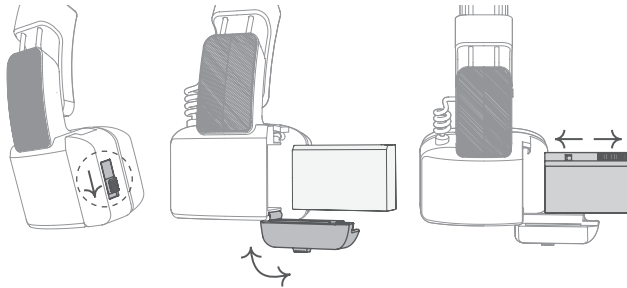

15

Disassembly

Slide up the battery compartment switch and open the cover, then you can take out the battery.

Pairing

The headsets are out-of-the-box since they have been paired in factory. Pairing is required only when a new headset needs to be connected to the existing system. During the pairing process, please make sure that the master headset and other headsets in the system are powered on and connected, and start pairing by referring to the following operation steps.

1. Set a headset as the master headset, the other 1~4 headsets as the remote headset.

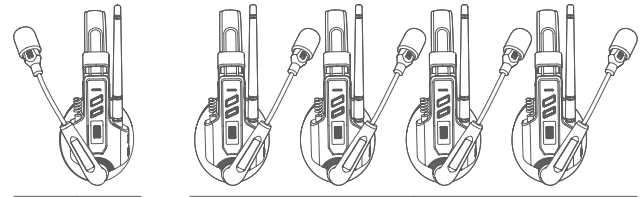

Master Headset

Remote Headset

2. Press and hold the pairing buttons of all headsets for 5s to start pairing, the voice announcement "to be connected" means they are connected. Then press the pairing button of a certain headset, the voice announcement will indicate it's master headset or remote headset.

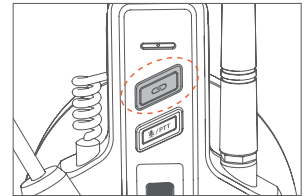

3. Reboot all headsets then they are ready for use.

Note:

1. One master headset can be connected to four remote headsets at most.
2. The master headset and remote headsets are out-of-the-box since they have been paired in factory.

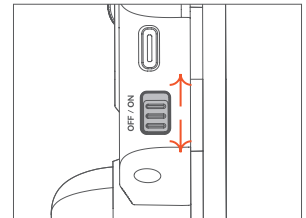

16

Searching

Press the searching button twice quickly to start searching, indicators of all the headsets will flash red and green quickly and alternately for 15s. This function is aimed at quickly distinguishing the headsets within the same group.

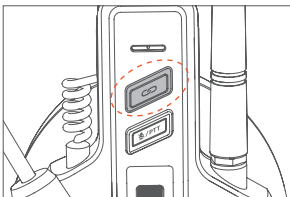

Mute Mode/PTT Mode (Mic On Status)

Press and hold --- PTT mode

Release --- Mute

Press once --- Resume to duplex intercom mode

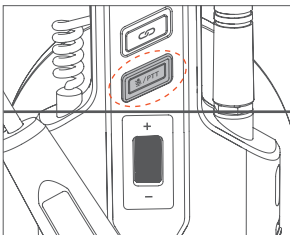

Volume Adjustment

Rotate up --- Increase volume

Rotate down --- Decrease volume



Turn On/Off the Microphone

The microphone can be worn in both left and right directions, adjusted up and down by 270 degrees. It is able to monitor and pick up sound after lowering down, with a voice announcement of "Microphone on". But it can only monitor after lifting up in a range of 90 degrees, pick up sound is unavailable, with a voice announcement of "Microphone off".

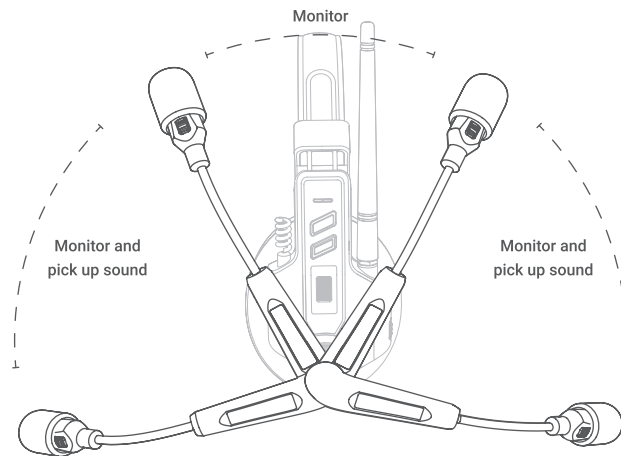

Monitoring through the External Earphone

Earphone jack can be connected to external earphone to monitor the intercom.

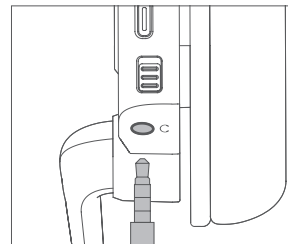

Battery Charging Case

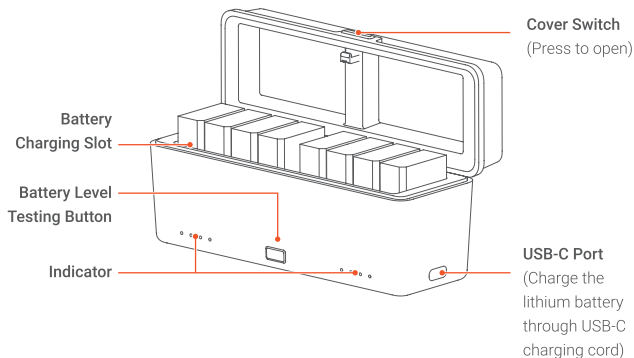

Indicators Instructions

There are eight indicators on the charging case, corresponding to eight charging slots respectively. The corresponding indicator will light up after the charging case is powered on and the lithium battery is inserted, and the indicator will turn off if the lithium battery is pulled out.

Indicators after Inserting the Battery in Power on Status

Flash green --- Charging

Constant on green --- Fully charged

Red fast flash for 10s --- Low temperature protection

Indicators after Inserting the Battery in Power off Status

Insert the lithium battery when the charging case is powered off, press the battery level testing button, the indicators will display the corresponding battery levels.

Constant on red	Battery level: 0%~40%
Constant on yellow	Battery level: 40%~80%
Constant on green	Battery level: 80%~100%

Indicators Instructions

Product Name	Headset	Battery Charging Case
Model	SkyTalk Air	STA-CH08
Wireless Band	2.4GHz	/
Max. Transmission Distance	500m	
Frequency Response	150Hz-7KHz	
Signal to Noise Ratio	≥71dB @94dBSPL,1KHz	
Max. SPL	>115dBSPL	
Lithium Battery Parameters	DC3.8V, 760mAh, 2.888Wh	
USB-C Input	5V --- 0.6A	5V --- 2A, 9V --- 2A
USB-C Output	/	4.35V --- 0.2A
Charging Time (USB-C Charging)	Approx. 2h	/
Battery Life	Approx. 20h	
Adjustable Head Circumference Range	Approx. 54-58cm	
Working Environment Temperature	0°C ~40°C	
Net Weight (With Battery)	Approx. 207g	Approx. 156g

Specifications and data may subject to changes without notice.

Warning

Operating Frequency: 2404MHz-2424MHz, 2428MHz-2478MHz

SkyTalk Air Maximum EIRP Power: -11.08dBm

Declaration of Conformity

GODOX Photo Equipment Co.,Ltd. hereby declares that this equipment are in compliance with the essential requirements and other relevant provisions of Directive 2014/53/EU. In accordance with Article 10(2) and Article 10(10), this product is allowed to be used in all EU member states. For more information of DoC, Please click this web link:

<https://www.godox.com/eu-declaration-of-conformity/>

The device complies with RF specifications when the device used at 0mm from your body.

FCC Caution

This device complies with part 15 of the FCC Rules. Operation is subject to the following two conditions:

- (1) This device may not cause harmful interference, and
- (2) this device must accept any interference received, including interference that may cause undesired operation.

Any Changes or modifications not expressly approved by the party responsible for compliance could void the user's authority to operate the equipment.

Note: This equipment has been tested and found to comply with the limits for a Class B digital device, pursuant to part 15 of the FCC Rules. These limits are designed to provide reasonable protection against harmful interference in a residential installation. This equipment generates uses and can radiate radio frequency energy and, if not installed and used in accordance with the instructions, may cause harmful interference to radio communications. However, there is no guarantee that interference will not occur in a particular installation. If this equipment does cause harmful interference to radio or television reception, which can be determined by turning the equipment off and on, the user is encouraged to try to correct the interference by one or more of the following measures:

- Reorient or relocate the receiving antenna.
- Increase the separation between the equipment and receiver.
- Connect the equipment into an outlet on a circuit different from that to which the receiver is connected.
- Consult the dealer or an experienced radio/TV technician for help.

The device has been evaluated to meet general RF exposure requirement.
The device can be used in portable exposure condition without restriction.

IC Warning

This device contains licence-exempt transmitter(s)/receiver(s) that comply with Innovation, Science and Economic Development Canada's licence-exempt RSS(s). Operation is subject to the following two conditions:

- (1) This device may not cause interference, and
- (2) This device must accept any interference, including interference that may cause undesired operation of the device.

L'émetteur/récepteur exempt de licence contenu dans le présent appareil est conforme aux CNR d'Innovation, Sciences et Développement économique Canada applicables aux appareils radio exempts de licence. L'exploitation est autorisée aux deux conditions suivantes:

- (1) Cet appareil ne peut pas causer d'interférences, et

(2) Cet appareil doit accepter toute interférence, y compris celles qui pourraient entraîner un fonctionnement accidentel de l'appareil.

Any Changes or modifications not expressly approved by the party responsible for compliance could void the user's authority to operate the equipment.

Tout changement ou modification non expressément approuvé par la partie responsable de la conformité pourrait annuler l'autorité de l'utilisateur à faire fonctionner l'équipement.

Note: This equipment has been tested and found to comply with the limits for a Class B digital device, pursuant to part 15 of the FCC Rules. These limits are designed to provide reasonable protection against harmful interference in a residential installation. This equipment generates uses and can radiate radio frequency energy and, if not installed and used in accordance with the instructions, may cause harmful interference to radio communications. However, there is no guarantee that interference will not occur in a particular installation. If this equipment does cause harmful interference to radio or television reception, which can be determined by turning the equipment off and on, the user is encouraged to try to correct the interference by one or more of the following measures:

- Reorient or relocate the receiving antenna.
- Increase the separation between the equipment and receiver.
- Connect the equipment into an outlet on a circuit different from that to which the receiver is connected.
- Consult the dealer or an experienced radio/TV technician for help.

Remarque: Cet équipement a été testé et déclaré conforme aux limites imposées aux appareils numériques de classe B, conformément à la partie 15 des règles de la FCC. Ces limites sont conçues pour fournir une protection raisonnable contre les interférences nuisibles dans une installation résidentielle. Cet équipement génère, utilise et peut émettre de l'énergie de fréquence radio et, s'il n'est pas installé et utilisé conformément aux instructions, peut causer des interférences nuisibles aux communications radio. Cependant, il n'y a aucune garantie que des interférences ne se produiront pas dans une installation particulière. Si cet équipement provoque des interférences nuisibles à la réception radio ou télévision, ce qui peut être déterminé en éteignant et en rallumant l'équipement, l'utilisateur est invité à essayer de corriger les interférences par une ou plusieurs des mesures suivantes :

- Réorienter ou déplacer l'antenne de réception.
- Augmenter la distance entre l'équipement et le récepteur.
- Connecter l'équipement à une prise sur un circuit différent de celui auquel le récepteur est connecté.
- Consulter le revendeur ou un technicien radio/TV expérimenté pour obtenir de l'aide.

RF warning for Portable device:

The device has been evaluated to meet general RF exposure requirement. The device can be used in portable exposure condition without restriction.

Avertissement RF pour les appareils portables:

L'appareil a été évalué pour répondre aux exigences générales d'exposition aux radiofréquences (RF). L'appareil peut être utilisé dans des conditions d'exposition portable sans restriction.

产品保修

尊敬的用户,本保修卡是申请保修服务的重要凭证,请您配合销售商填写并妥善保管,谢谢!

产品信息	型号	产品条码
用户信息	姓名	联系电话
	通讯地址	
销售商信息	名称	
	联系电话	
	通讯地址	
	销售日期	
备注		

注:此表应由销售商盖章确认。

产品信息

产品及部件的相应保修期按相关的《产品保修信息》执行。保修期自产品首次购买日起算,购买日以购买产品时保修卡登记日期为准。

保修期

本文件适用于相关《产品保修信息》(见后面说明)所列产品,其他非属此范围的产品或部件(如促销品、赠品及其他出厂后附加的部件等)不在此保修承诺内。

如何获得保修服务

要保修服务,您可直接与产品销售商或授权服务机构联系,也可拨打神牛产品售后服务电话,与我们联系,由我们的服务人员为您安排服务。申请保修时,您应提供有效的保修卡作为保修凭证,方可获得保修。如您不能提供有效的保修卡,则在我们可确认产品或部件属于保修范围的情况下,也可以为您提供保修,但这不作为我们的义务。

不适用保修的情况

如产品存在下列情况,本文件项下的保证和服务将不适用①产品或部件超过相应保修期;②错误或不适当使用、维护或保管导致的故障或损坏,如:不当搬运;非按产品合理预期用途使用;不当插拔外接设备;跌落或外力挤压;接触或暴露于不适当温度、溶剂、酸碱、水浸或潮湿环境;③由非神牛授权机构或人员安装、修理、更改、添加或拆卸造成的故障或损坏;④产品或部件原有识别信息被修改变更或删除;⑤无有效保修卡;⑥使用非合法授权、非标准或非公开发行的软件造成的故障或损坏;⑦因不可抗力或意外事件造成的故障或损坏;⑧其他非因产品本身质量问题导致的故障或损坏。遇上述情况,您应向相关责任方寻求解决,神牛对此不承担任何责任。因非在保修期或保修范围内的部件、附件或软件导致产品不能正常使用的,不是保修范围内的故障。产品使用过程中正常的脱色、磨损和消耗,不是保修范围内的故障。

产品保修和服务支持信息

产品的保修期和服务类型按以下《产品保修信息》执行:

产品类型	选件名称	保修期(月)	保修服务类型
部件	主机	12	客户送修
	电池	3	
	充电器等带电性能的部件	12	
其他	如电源线、同步线、电池盒、防风棉、防风毛罩、锁紧装置、手提绳、扎带、魔术贴、领夹、便携袋、包装等	无	无保修

神牛产品售后服务电话 0755-29609320-8062

Warranty

Dear customers, as this warranty card is an important certificate to apply for our maintenance service, please fill in the following form in coordination with the seller and safe-keep it. Thank you!

Product Information	Model	Product Code Number
Customer Information	Name	Contact Number
	Address	
Seller Information	Name	
	Contact Number	
	Address	
	Date of Sale	
Note		

Note: This form shall be sealed by the seller.

Applicable Products

The document applies to the products listed on the Product Maintenance information (see below for further information). Other products or accessories (e.g. promotional items, giveaways and additional accessories attached, etc.) are not included in this warranty scope.

Warranty Period

The warranty period of products and accessories is implemented according to the relevant Product Maintenance Information. The warranty period is calculated from the day (purchase date) when the product is bought for the first time, and the purchase date is considered as the date registered on the warranty card when buying the product.

How to Get the Maintenance Service

If maintenance service is needed, you can directly contact the product distributor or authorized service institutions. You can also contact the Godox after-sale service call and we will offer you service. When applying for maintenance service, you should provide valid warranty card. If you cannot provide valid warranty card, we may offer you maintenance service once confirmed that the product or accessory is involved in the maintenance scope, but that shall not be considered as our obligation.

Inapplicable Cases

The guarantee and service offered by this document are not applicable in the following cases: ①. **The product or accessory has expired its warranty period;** ②. **Breakage or damage caused by inappropriate usage, maintenance or preservation, such as improper packing, improper usage, improper plugging in/out external equipment, falling off or squeezing by external force, contacting or exposing to the improper temperature, solvent, acid, base, flooding and damp environments, etc;** ③. **Breakage or damage caused by non-authorized institution or staff in the process of installation, maintenance, alternation, addition and detachment;** ④. **The original identifying information of product or accessory is modified, alternated, or removed;** ⑤. **No valid warranty card;** ⑥. **Breakage or damage caused by using illegally authorized, nonstandard or non-public released software;** ⑦. **Breakage or damage caused by force majeure or accident;** ⑧. **Breakage or damage that could not be attributed to the product itself.** Once met these situations above, you should seek solutions from the related responsible parties and Godox assumes no responsibility. The damage caused by parts, accessories and software that beyond the warranty period or scope is not included in our maintenance scope. The normal discoloration, abrasion and consumption are not the breakage within the maintenance scope.

Maintenance and Service Support Information

The warranty period and service types of products are implemented according to the following Product Maintenance Information:

Product Type	Name	Maintenance Period(month)	Warranty Service Type
Parts	Product Main Body	12	Customer sends the product to designated site
	Battery	3	
	Charger, Electrical Parts etc.	12	
Other Items	Power Cable, Sync Cable, Battery Case, Windscreen Foam, Wind Cap, Locking Device, Lanyard, Tie, Velcro Tape, Clip, Bag, Package etc.	No	Without warranty

Godox After-sale Service Call 0755-29609320-8062