

KERNOM

ELIPSE
USER MANUAL

V 1 - 13.02.2025

KERNOM

ENJOY YOUR NEW MODULATION PLAYGROUND

The ELIPSE has been designed to offer you a unique experience with modulation effects, giving you access to all the main analog modulation tones in one device. The ELIPSE lets you explore these tones in an exciting way, allowing you to craft any modulation sound you've ever heard — or even those you haven't yet imagined — while also surprising you with unexpected tones and creative possibilities.

At the heart of the ELIPSE is its patented **Analog Morphing Core**® circuit, based on an analog audio path controlled by digital technologies, combining the warmth and clarity of analog tones, with the unique ability to continuously morph from one effect to another and the possibility to save your favorite setting into a preset.

Thanks to advanced MIDI features, you can save and recall presets, manage Tap Tempo and MIDI Clock, and even connect an expression pedal to seamlessly morph between two presets, making sound exploration dynamic and playful.

With the ELIPSE, we wish you an incredible journey into the fascinating world of modulation effects. We hope you will enjoy it as much as we did while designing and imagining it — whether you're performing live, working in the studio, or experimenting at home !

The Kernom Team



HOW THE ANALOG MORPHING CORE WORKS ?

The idea behind our product is to combine the sonic benefits of analog circuits with the advanced control and flexibility enabled by digital technology. The Analog Morphing Core is specifically designed to achieve this synergy.

Our pedal features analog audio processing, meaning that all key sound characteristics are shaped entirely by analog circuits.

In the ELIPSE, the modulated delay used for all pitch-shifting effects is a blend of digital memory delay and a proprietary analog nonlinear circuit, which provides the tonal characteristics of a BBD (Bucket Brigade Device) while offering a higher dynamic range.

Using the MOOD and SWIRL knobs simultaneously adjusts the bias points of the analog nonlinear circuit and the delay parameters, allowing you to morph seamlessly between different effects.

Note : Due to the digital control and processing involved in the Analog Morphing Core, the signal path is converted to the digital domain at some point. However, this is done without compromising the warmth and character of the analog circuitry. This process introduces a latency of approximately 1.2 ms.

WHAT ARE MODULATION EFFECTS ?

Modulation effects are fundamental in music, both in the studio and on stage. They first emerged in the 1950s with the introduction of tremolo effects built into amplifiers, and later evolved into vibrato, chorus, phaser, and flanger pedals in the 1960s and 1970s.

The term “modulation effect” comes from the fact that one core aspect of the sound is cyclically modulated by a low-frequency oscillator (LFO).

In a **tremolo** effect, the volume of the sound is modulated by the LFO, creating rhythmic variations in the playing.

In **vibrato**, the pitch of the sound is modulated, resulting in a similar effect to bending the strings of a guitar.

In **chorus**, the pitch is also modulated, but here, the direct signal blends with the modulated signal, producing a fuller, richer sound, similar to a vocal choir.

A **flanger** uses delay, with the delay time modulated by the LFO. The delayed signal is then mixed with the direct signal, creating a comb-filter effect that cycles, evoking the sound of a jet plane flying by.

It's worth noticing that in analog effects, chorus and flanger are created the same way, with the only difference being a longer delay time for the chorus.

Phaser effects are generated by all-pass filters, which modulate the phase of the signal. The direct and modulated signals are blended together, creating an effect similar to flanger, but with its own distinctive tone. This effect can be used to create subtle, evolving textures or add a groovy, funky feel to a rhythm part.

The **Vibe** effect is a unique type of phaser circuit with distinct all-pass frequencies.

Finally, the **rotary** effect combines several of these modulations, simulating the sound of a rotating speaker to produce a rich, swirling movement.

Used across all musical genres, modulation effects bring depth, dynamics, and harmonic richness to the sound. Whether applied to guitars, synthesizers, or vocals, they create a wide range of atmospheres, from psychedelic to groovy. Their versatility makes them indispensable tools for musicians and producers alike.

- Welcome
- How does the Analog Morphing Core works ?
- The modulation effects

05 — MAIN FEATURES

- 06** — Front panel
- 07** — Rear panel
- 08** — How to start
- 09** — The MOOD knob
- 10** — MIX and DEPTH knob
- 11** — SHAPE and SWIRL
- 12** — Sounds examples

13 — ADVANCED FEATURES

- 14** — How to save and recall the internal favorite preset ?
- 15** — How to modify the internal favorite preset ?
- 16** — How to use an expression pedal ?
- 17** — How to reset the factory setting ?
- 18** — How to change the footswitches behaviour ?

19 — MIDI FEATURES

- 20** — Introduction to MIDI
- 21** — How to set the MIDI channel ?
- 22** — How to configure the MIDI OUT connector ?
- 23** — How to save a MIDI preset ?

- 24** — How to recall a MIDI preset ?
- 25** — How to modify a MIDI preset and save the modification into the same preset ?
- 26** — How save one MIDI preset into the internal favorite preset
- 27** — How to modify a MIDI preset and save the modification into the internal favorite preset ?
- 28** — How to save a MIDI preset into another MIDI preset ?
- 29** — How save the internal preset into one of the MIDI preset ?

- 30** — The expression pedal using a MIDI preset - **step 1**
- 31** — The expression pedal using a MIDI preset - **step 2**
- 32** — The expression pedal using a MIDI preset - **step 3**
- 33** — The expression pedal using a MIDI preset - **step 4**

- 34** — MIDI Control Change messages with the ELIPSE
- 35** — External MIDI footswitch as a tap tempo
- 36** — MIDI clock
- 37** — MIDI tempo subdivision

38 — TECHNICAL SPECIFICATIONS

40 — WARRANTY

E L I P S E
MAIN FEATURES

FRONT PANEL

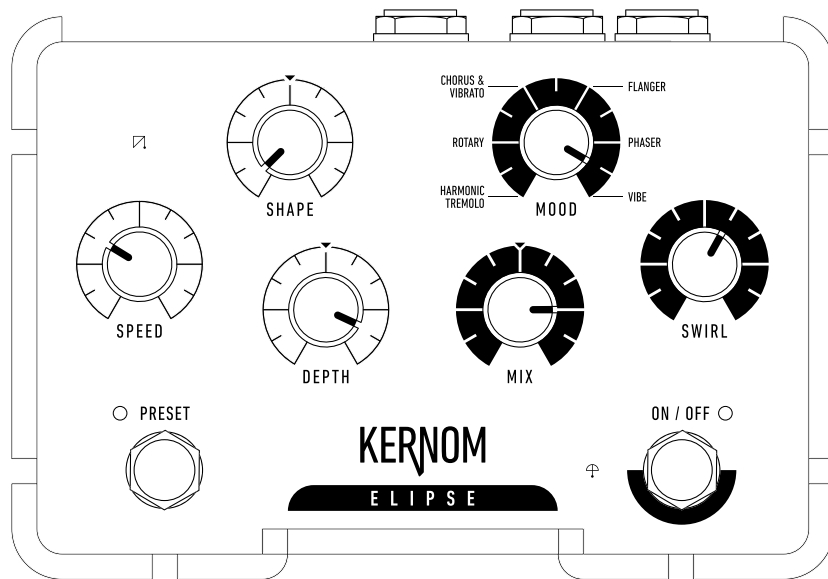
**ON/OFF FOOTSWITCH**

Engages and disengages the effect.

PRESET FOOTSWITCH

The PRESET footswitch lets you save and recall one internal favorite preset. (see page 14).

LEDS

Indicate the pedal's operational state based on its current usage.

Note : The ON/OFF Led pulses in tempo with the actual LFO speed when the effect is engaged

CONTROLS ASSOCIATED WITH THE MODULATION (LEFT SIDE)**SPEED**

The SPEED adjusts the modulation rate.

SHAPE

SHAPE modifies the modulation waveform, with a classic triangular shape at the mid-position. (see page 11)

DEPTH

DEPTH controls the intensity of the modulation effect. (see page 10)

CONTROLS ASSOCIATED WITH THE CORE EFFECTS (RIGHT SIDE)**MOOD**

Access all the classic and iconic modulation effects with a single knob.

No need to choose between a chorus or a flanger : simply turn the knob until you find the sound you love. (see page 9)

MIX

MIX controls the blend between wet and dry signals.

At the mid-position, it provides a 50/50 mix for classic effects. (see page 10)

SWIRL

SWIRL adds a secondary layer to the main effect.

The first part of the knob's sweep introduces a slow phaser, while the second part adds a drive effect. (see page 11)

REAR PANEL

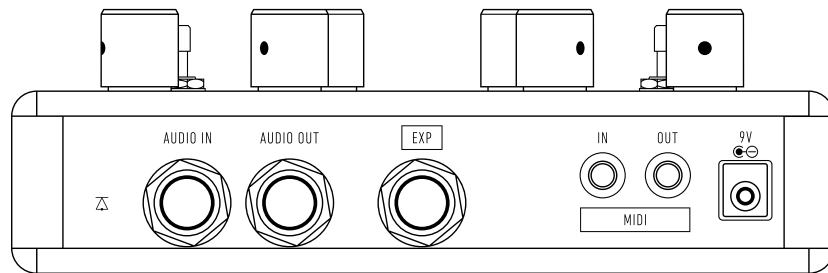

AUDIO IN

Universal mono audio input (instrument or line level).

AUDIO OUT

Mono audio output. Connect this to your next pedal or directly to your amp.

EXP

Expression pedal input. Enables continuous control of all knobs using an expression pedal. Use a stereo cable (not included) to connect.

MIDI IN

Midi input (see page 19)

MIDI OUT

Midi output

POWER

Connect a standard 9V center-negative power supply with a **minimum output of 150 mA** to power the pedal.



IMPORTANT: The ELIPSE uses TRS mini jack type A connections for its MIDI functionalities and is compatible with 5-pin DIN connectors via an external adapter (not included).



Note : There are two types of MIDI-to-TRS cables: Type A and Type B.

The ELIPSE is compatible only with Type A cables.

Be sure to purchase a MIDI-to-TRS Type A cable for use with your ELIPSE.

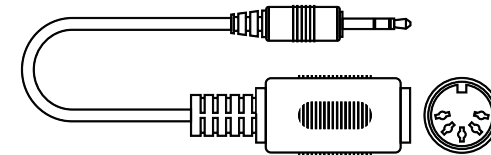

TRS mini jack type A

The ELIPSE features a low-noise input stage that can accept instrument signals, such as electric guitars or basses, and can also handle line-level signals from mixing desks or synthesizers.



Tip : Typically, a modulation pedal is placed after overdrive, distortion, or fuzz pedals in the signal chain. This setup enhances the harmonics created by the drive circuits and adds movement to the sound.

However, placing a drive pedal after the ELIPSE can yield entirely different results, creating truly unique and interesting tones.

Don't hesitate to experiment with different placements of your ELIPSE in the signal chain!

EASY STEP TO START EXPLORING

IF YOU WANT A FOOLPROOF PROCESS TO GET STARTED WITH THE PEDAL, FOLLOW THESE EASY STEPS :



1. Set all the knobs to their middle positions, except for the SWIRL knob, which should be set to minimum.
2. Begin with the MOOD knob at its minimum to start your modulation exploration.
3. Gradually turn the MOOD knob to explore the six different effects inside the ELIPSE. You'll discover the classic, warm, and smooth tones of these analog modulation effects.
4. Adjust the SPEED knob to match the tempo of your music.

 **Tip :** When using a fast speed setting, don't hesitate to lower the DEPTH knob if the effect feels too strong or experimental (try using the fast vibrato preset for this).

THE MOOD KNOB

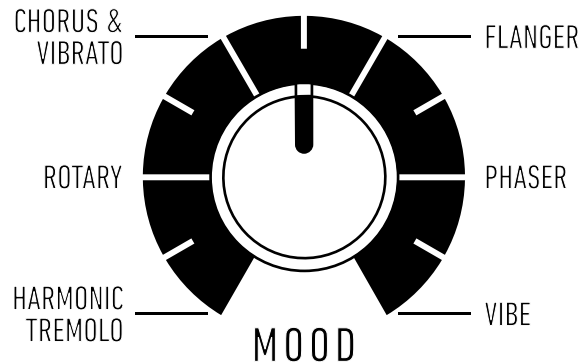

CHORUS VIBRATO
Pitch shift modulation

ROTARY
Blend amplitude, pitch shift
and phase modulation

HARMONIC TREMOLO
Amplitude modulation

FLANGER
Comb filter modulation

PHASER
Phase shift modulation

VIBE
Classic vibe phase modulation

THE MOOD KNOB IS THE CENTERPIECE OF THE ELIPSE USER EXPERIENCE, ALLOWING YOU TO EXPLORE YOUR MODULATION PLAYGROUND IN A TRULY UNIQUE WAY.

The MOOD knob is a continuous control that unlocks the ELIPSE's limitless modulation possibilities. This innovative feature lets you seamlessly morph between various modulation effects, enabling you to select classic effects at specific positions or craft entirely unique hybrid sounds in between.

With the MOOD knob, there's no need to choose between a chorus or a flanger—simply turn the dial until you discover the sound you love.



Tip : Start by selecting the labeled positions to experience the classic effects instantly. Then, experiment with the in-between positions to uncover new and unique tonal textures.

The effects order is designed to produce musical results in any position.

The rotary effect is placed between the amplitude modulation of the tremolo effect and the modulated pitch shift of a chorus/vibrato effect, as it incorporates elements of both due to the Doppler effect associated with a rotating speaker. This placement allows you to gradually select the type of modulation that best suits a specific song.

Chorus and flanger are positioned close together because they are technically variations of the same effect. This design lets you transition smoothly from a classic chorus to a full jet flanger. Similarly, you can move seamlessly from the evenly spaced comb filtering of the flanger to the smoother phase shifting of a phaser.

Finally, since vibe effects are a specific type of phaser circuit, the last portion of the MOOD knob offers a wide range of phasing variations, giving you even more creative possibilities.



Note : In MOOD "harmonic tremolo" you can access the harmonic tremolo by setting the MIX in mid position and access full range tremolo setting the MIX to the max position.



Note : In MOOD "Vibrato & Chorus" you can access chorus effect by setting the MIX in mid position, and access vibrato effect by setting the MIX to the max position.

10 GENERAL

THE MIX AND DEPTH KNOBS

EFFECT EXPLORATION :

THE MIX AND DEPTH KNOBS

EXPLORE THE TWO NEXT CONTROLS : **THE MIX KNOB AND THE DEPTH KNOB, BOTH OF WHICH AFFECT THE INTENSITY OF THE EFFECT, BUT IN DIFFERENT WAYS.**

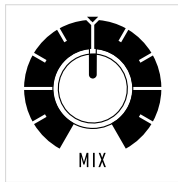

THE MIX KNOB BLENDS THE DRY AND WET SIGNALS.

At minimum, only the dry signal will be heard with no effect applied. At the mid-position, you'll experience each effect in its classic form.

Turning the knob to the right increases the effect's intensity, with results varying depending on the MOOD position.

 **Tip :** In the harmonic tremolo MOOD, setting the MIX knob to the mid-position will produce the harmonic tremolo effect. Setting it to the maximum position will create the stronger, full-amplitude modulation of a standard tremolo.



HARMONIC

FULL TREMOLO

 **Tip :** In the chorus & vibrato MOOD, setting the MIX knob to noon creates the classic analog chorus effect, with dry and wet signals blended equally. Turning the MIX knob fully to the right allows only the pitch-shifted signal to pass, resulting in a full vibrato effect.



CHORUS

VIBRATO

 **Tip :** In the flanger and phaser MOODs, turning the MIX knob from mid to maximum introduces feedback to the sound, creating a strong comb-filter effect.

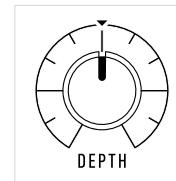

USE THE DEPTH CONTROL TO DETERMINE THE AMOUNT OR AMPLITUDE OF MODULATION APPLIED TO THE EFFECTS.

A low DEPTH setting results in subtle modulation, while a high DEPTH setting makes the effect more pronounced, creating noticeable variations in the sound (such as volume changes in a tremolo or pitch variations in a chorus).

 **Tip :** In the harmonic tremolo MOOD effect, set the MIX knob to maximum for full amplitude modulation. Then, set the DEPTH to a medium position for a classic smooth tremolo sound. Turning the DEPTH to maximum will create a sharper, stuttered effect, similar to square wave modulation at full depth.

 **Tip :** Set the MOOD knob to the phaser position, with both the DEPTH and MIX knobs at mid-position. Then, gradually move the DEPTH knob from minimum to maximum, return it to mid, and repeat the same process with the MIX knob. You'll experience how each control affects the overall intensity of the effect.

11 GENERAL THE SHAPE AND SWIRL KNOBS

ADVANCED EXPLORATION :

THE SHAPE AND SWIRL KNOBS

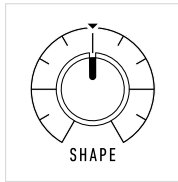

USE THE SHAPE CONTROL TO ADJUST THE WAVEFORM OF THE LOW-FREQUENCY MODULATOR.

For most effects, keeping the control at noon provides the classic waveform associated with the chosen tone : a perfect blend of triangular and sine waveforms.

Turning it to the left creates sharper transitions, while turning it to the right produces a smoother result. It's similar to adjusting the pulse width of a square wave but applied to sine waves.

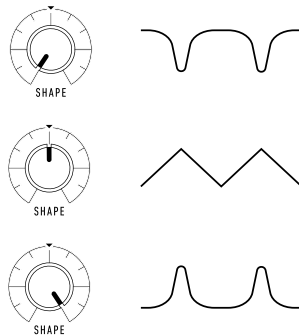

Tip : Set the MOOD knob to tremolo, with the MIX and DEPTH knobs at maximum, then turn the SHAPE knob to hear how it changes the modulation waveform.



Tip : In the Chorus/Vibrato MOOD, a hidden feature is associated with the SHAPE control. Turning this knob from mid to max adds two additional modulators in different phases, creating the classic and unique tri-chorus effect.

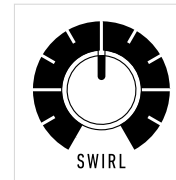

UNLEASH THE ELIPSE'S SECRET WEAPON : THE SECONDARY EFFECTS CIRCUIT !

SWIRL adds a secondary layer to the main effect.

The first part of the knob's sweep introduces a slow phaser, while the second part adds a drive effect.

SLOW PHASER

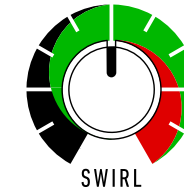

DRIVE

The ELIPSE features a second modulation circuit with a unique and specifically developed slow phaser, controlled by the SWIRL knob.

This allows you to layer the phaser onto any main effect.

The first half of the SWIRL knob's range controls the phaser's intensity: no effect at minimum, and full phasing intensity at the midpoint.



Note : The speed of this special phaser is not adjustable, but it's been carefully calibrated to blend seamlessly with any of the main modulation effects.

The second half of the SWIRL knob's range introduces a drive circuit inspired from the RIDGE.

This feature allows you to add drive after the modulation effect, complementing the classic pedalboard setup where drive pedals are placed before modulation.

As you turn the SWIRL knob beyond the midpoint, the drive intensity increases and applies to all effects.



Tip : To hear only the swirl second layer of effects:

1. Set all knobs to minimum for a clean, unaffected signal with only the direct sound.
2. Turn the SWIRL knob to the midpoint to hear just the slow phaser effect.
3. Turn the SWIRL knob to maximum to hear only the drive circuit, derived from the RIDGE

PRESET EXAMPLE FOR EACH OF THE MODULATION EFFECTS



TREMOLLO "BROKEN DREAM"



ROTARY "BLACK HOLE SUN"



CLASSIC ANALOG CHORUS



FLANGER "KRAVITZ"



SMOOTH 2 STAGE PHASER



PSYCHEDELIC VIBE

E L I P S E

ADVANCED FEATURES

HOW TO SAVE AND RECALL THE INTERNAL FAVORITE PRESET ?

The ELIPSE allow you to save internally one preset and recall it at any time with the specific footswitch.

Follow the following procedure to save all the knobs positions into the internal favorite preset.

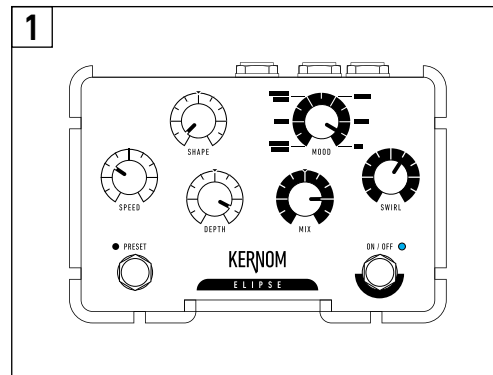

Dial in your favorite sound.

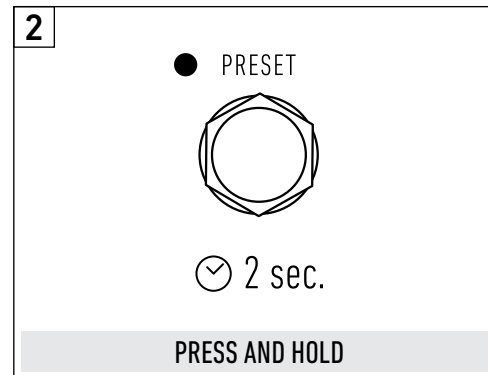

PRESS AND HOLD

Press and hold the PRESET footswitch to save your favorite settings.

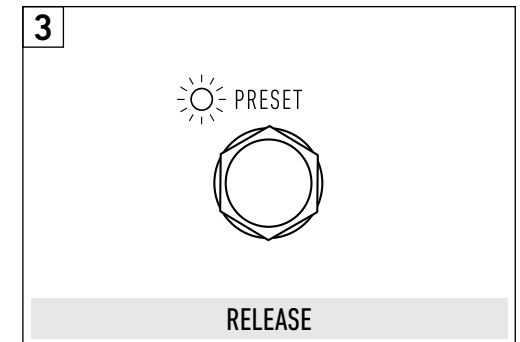

RELEASE

PRESET Led starts blinking white to confirm. Release PRESET footswitch. **Preset saved.**

For recalling the preset, just press the PRESET footswitch at any time..

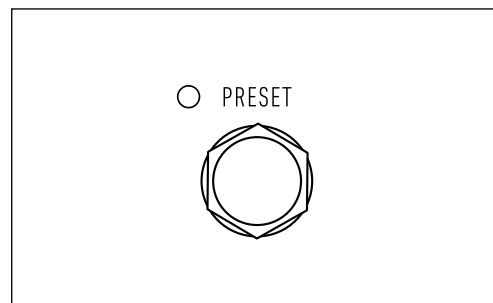

Press on the PRESET footswitch to recall your saved preset. Pressing multiple times toggles between your favorite preset and the setting defined by the knobs' current position.



Note : After recalling the favorite preset, be aware that the actual positions of the knobs are decorrelated from the parameters values used in the effect you are hearing. There is only one internal favorite preset. When you are saving a new internal preset, all the knobs settings that where saved before are erased.

HOW TO MODIFY THE INTERNAL FAVORITE PRESET AND SAVE THE MODIFICATIONS ?

You may want to recall the internal favorite preset, and modify one or more of the settings.

For example you want to keep the global tone of the preset, but only adjust the speed knob value to match a different song.

For that, just follow the next steps :

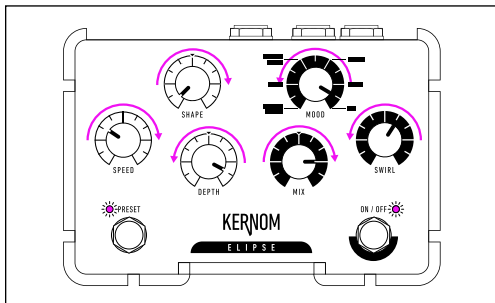

Repeat steps 2 and 3 on as many knobs as you like. If you repeat the steps on all 6 knobs, the pedal leaves the preset as all knobs are now active.

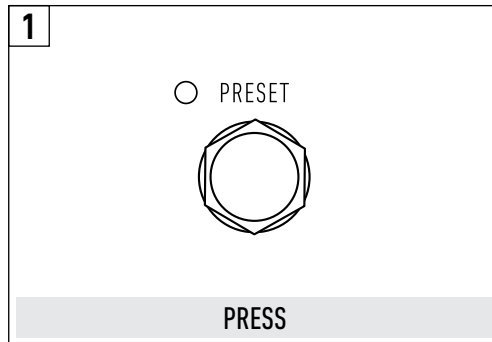

Recall your favorite preset by stepping on the Preset footswitch. The PRESET Led will turn white.

Note : The modification you have done only affect the sound you hear, but the value of knobs stored in the preset memory are unchanged at that time.

If you want to save the modifications in the preset memory, just follow the next step 4 :

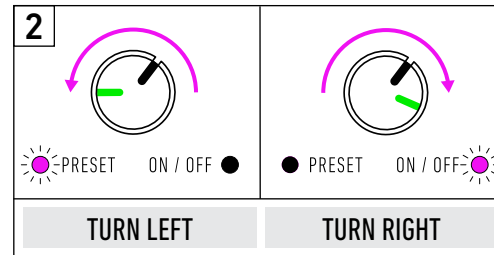

Move the knob you wish to modify. There will be no sound modification until you reach the saved value.
The Leds will help you: Turn left if the PRESET Led blink purple or turn right if the ON/OFF Led blink purple.

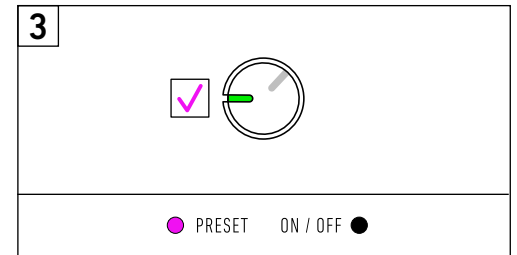

Once the saved position of the knob has been reached, the Leds stop blinking and the Preset Led stays purple, indicating the user is in a modified version of the preset. The knob is now active again and can be dialed in to a new preferred setting.

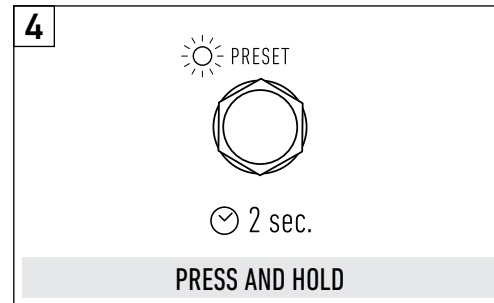

Once you are happy with the modifications, press and hold the preset footswitch until the preset Leds start blinking rapidly in white for 2 seconds to confirm that the preset is saved.

Note : The knobs that have been made active and modified are updated, if some knobs were not made active again following the procedure described in steps 1 to 3, their previous values remain unchanged.

Tip : If you only want to know the knobs position of the internal favorite preset, without modifying them, follow the procedure turning the knob really slowly, and stop turning as soon the purple Led stops to blink and remain solid on.

HOW TO USE AN EXPRESSION PEDAL WITH THE ELIPSE ?

Using an expression pedal lets you morph between two different settings, as if they had multiple hands turning all the knobs simultaneously from one position to another.

The expression pedal will morph between the settings defined by the current knob positions at the heel position and the internal favorite preset values at the toe position.

For using an expression pedal, just follow the next step :

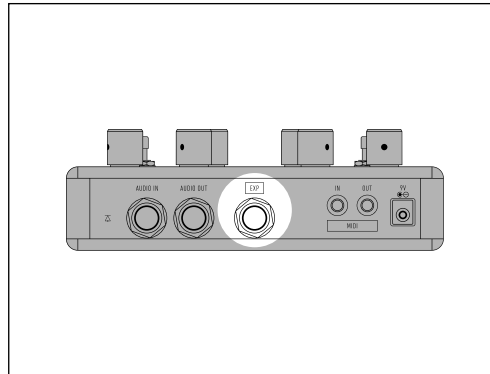

Connect an expression pedal to the EXP input.

HEEL POSITION

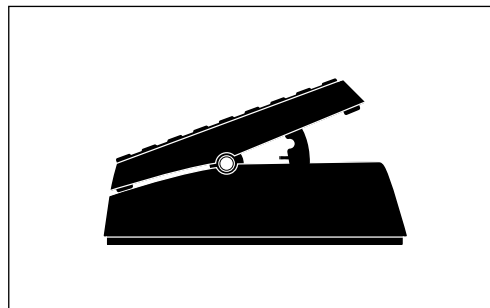

Actual knob position values

TOE POSITION

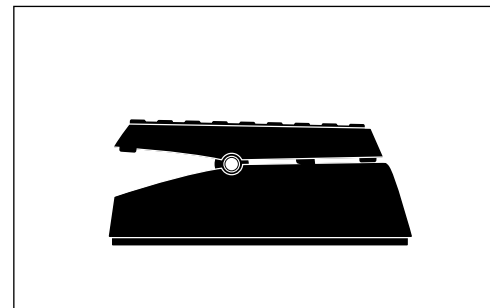



Internal favorite preset values

 **Tip :** For controlling the rotary speaker speed with an expression pedal, set the ELIPSE to the rotary MOOD position, set the knobs for the fast rotary sound you like, and save it into the internal favorite preset following the procedure on page 14.

Then move the SPEED knobs to the slow speed you like, and adjust the knobs for your taste.

Now when moving the expression pedal from heel to toe you can switch the rotary sound between the slow and the fast sound.

 **Note :** When the internal favorite preset is activated with the PRESET Led ON, the expression pedal is inactive.

 **Note :** At any time, if the knobs changes are not effective, just check if an expression pedal is connected and to the ellipse and is in the TOE position.

HOW TO RESET THE ELIPSE TO THE FACTORY SETTINGS ?

At any point, you may decide to reset the ELIPSE to its factory settings.

This will **erase all user created presets**, and toggle all functioning modes (MIDI out / thru, MIDI channels, Input level, etc.) back to their default settings.

In order to reset to factory settings, follow steps 1 to 6 :

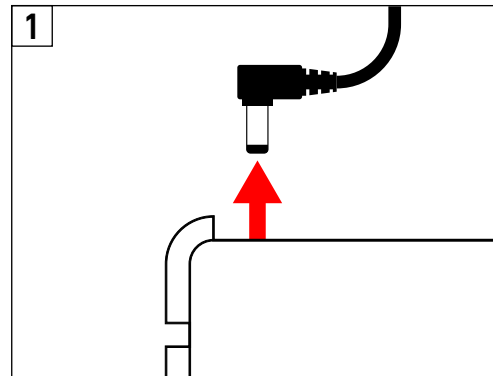

Unplug the power supply connector.

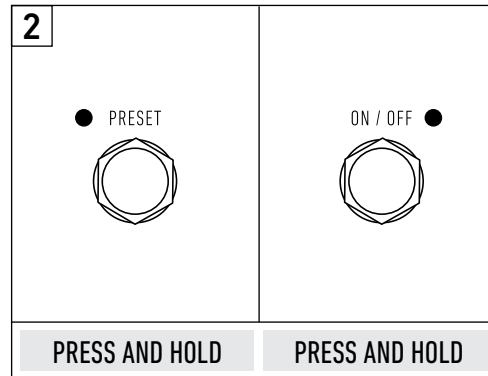

Press and hold both footswitch while replugging the power supply connector.

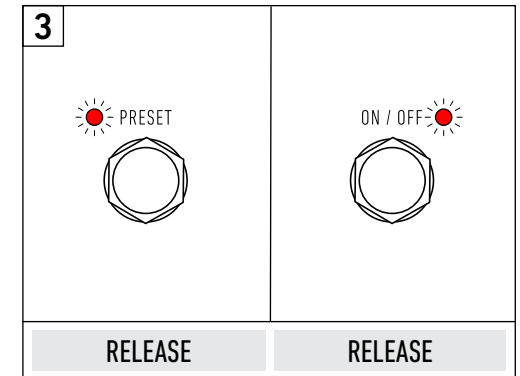

Both Leds start slowly blinking red. Release both footswitches.

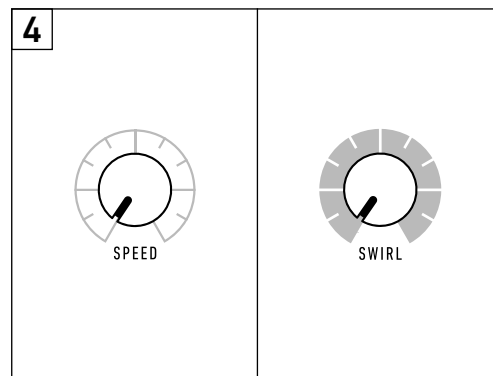

Set the SPEED and SWIRL to minimum. Both leds start blinking fast in red.

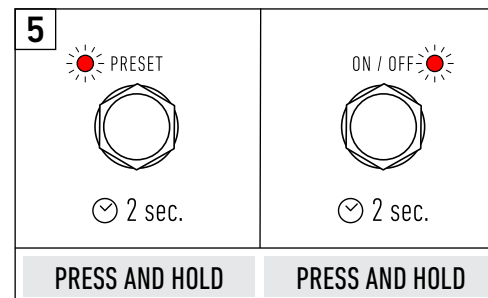

Press and hold both footswitches to validate until both Leds turn off. **The pedal just went back to the way it was out of the box.**

 **Tip :** If you has entered the reset mode by mistake and wants to exit the procedure without resetting the pedal to its factory settings, either unplug the pedal or simply set the SWIRL and SPEED knob NOT at minimum being in step 4, and finish the procedure.

HOW TO CHANGE THE ELIPSE FOOTSWITCH BEHAVIOUR MODE ?

By default, the ELIPSE footswitch triggers an action when released (not when pressed).

This behavior allows the footswitch to perform different actions based on the press duration : a short press recalls a preset, while a long press (more than 2 seconds) saves a preset.

However, in live situations, you may prefer a more responsive behavior, where the action is triggered immediately upon pressing the footswitch.

This can be enabled in a "reactive mode" but it limits the footswitch to a single action per press (in this mode, only preset recall is available).

With the ELIPSE, you can choose between the two modes for the footswitches.

In the default "standard mode", the footswitches operate with a release action, allowing preset-saving functions to be enabled.

In "reactive mode", the footswitches activate on press, but preset-saving functions are disabled.

You can switch from standard mode to reactive mode at any time by following this procedure :

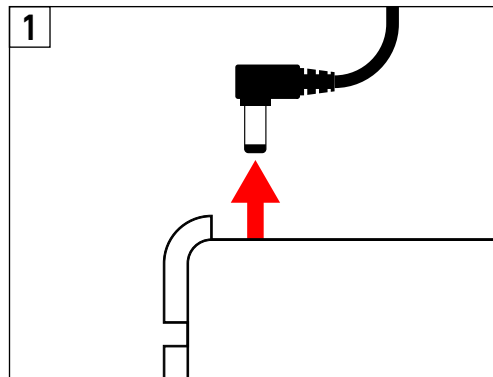

Unplug the power supply connector.

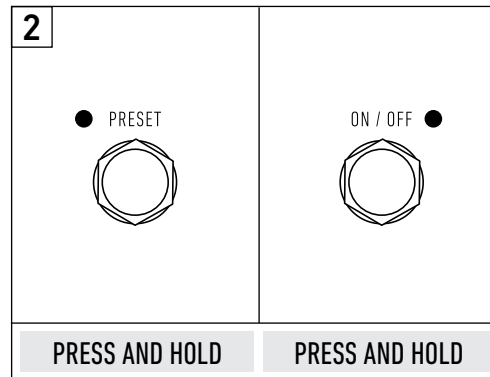

Press and hold both footswitch while replugging the power supply connector.

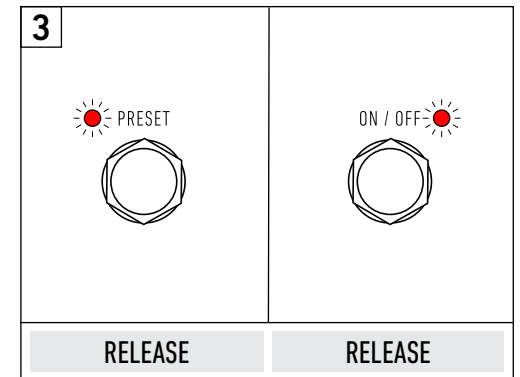

Both Leds start slowly blinking red. Release both footswitches.

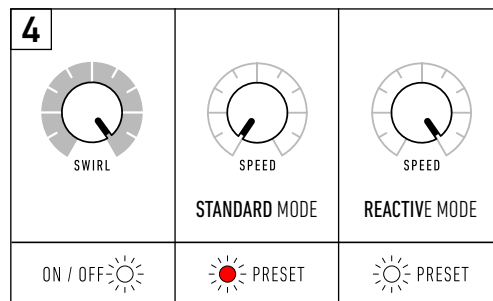

Set the SWIRL to max. The ON/OFF Led start to blink white. Then with the SPEED you can choose from standard mode at min (red Led) to reactive mode at max (white Led).

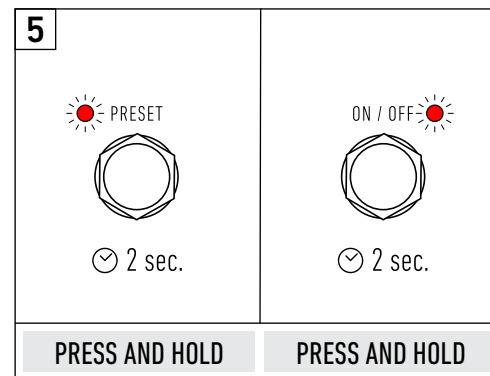

Press and hold both footswitches to validate until both Leds turn off.

E L I P S E
MIDI FEATURES

INTRODUCTION TO MIDI FEATURES

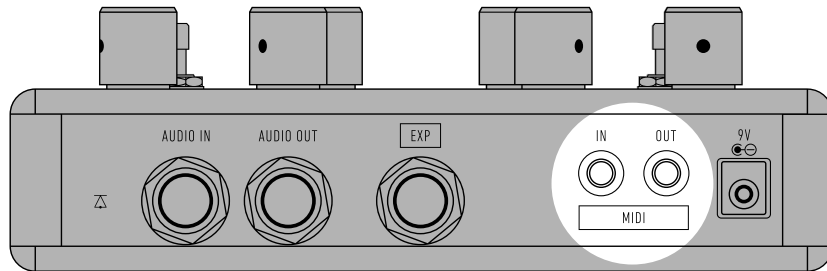

MIDI (Musical Instrument Digital Interface) is a technical standard that allows electronic musical instruments, computers, and other devices to communicate and control each other. It allows you to further take advantage of all the possibilities given by the ELIPSE internal technology :

MIDI gives you access to up to 128 presets that can be recalled with Program Changes (PC) messages at any point using an external MIDI switcher. This is more than enough to cover any kind of modulation needs. (See page 23 and 24)

The use of Control Change (CC) messages allows you to control all the ELIPSE'S internal settings with a connected MIDI controller. (See page 34)

MIDI can also be used to access tap tempo (page 35), MIDI clock (page 36) and time subdivision features (page 37).



Note : Preset number 0 is the favorite preset, which can therefore be saved either by following the procedure detailed on page 14 or the one detailed on page 23.

HOW TO SET THE MIDI CHANNEL ?

MIDI allows devices to send information to other devices and remotely change their settings and effect values. It supports 16 different channels for communication.

In a setup with multiple MIDI-enabled pedals, each pedal should be set to its own unique MIDI channel to ensure it only receives the messages intended for it, preventing interference from other devices.

Out of the box, the ELIPSE is set to function on MIDI channel 1.

Follow the next steps to change the MIDI channel assigned to the ELIPSE.



Note : You must set the same channel MIDI on the elipse and on the MIDI switcher you want to use to control the pedal.



Note : You can directly select one of the first three MIDI channels.

For channels 4 to 16, place the swirl knob in the fourth quadrant, then assign your MIDI controller to the desired MIDI channel and send any MIDI message.

The ELIPSE will recognize it and automatically set this MIDI channel as the chosen one.

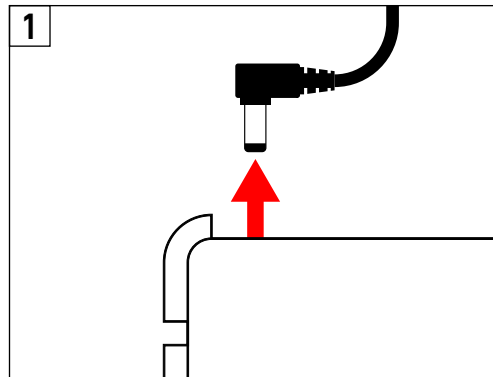

Unplug the power supply connector.

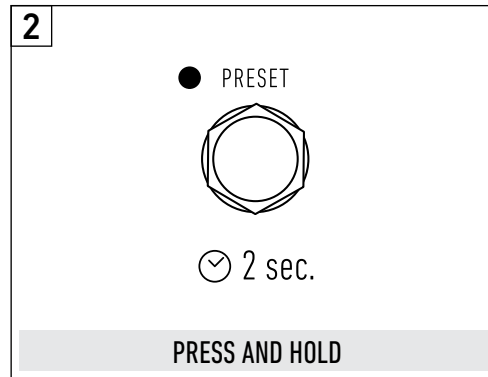

PRESS AND HOLD

Press and hold the PRESET footswitch while replugging the power supply connector

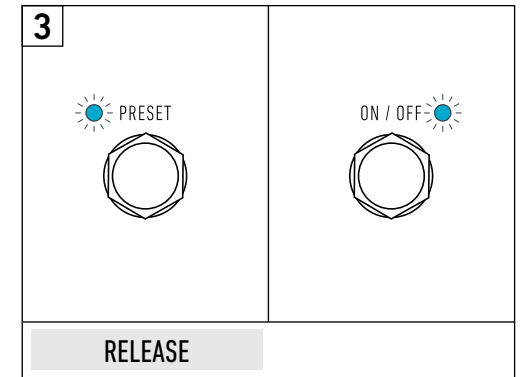

RELEASE

Both Leds start blinking blue. Release PRESET footswitch.

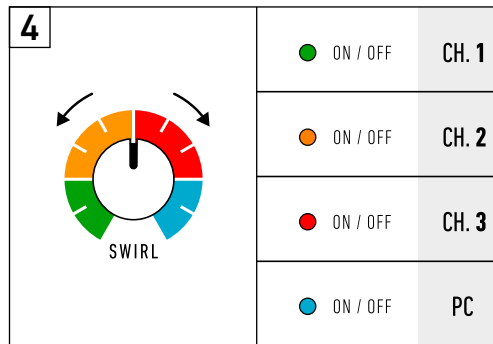

Turn the SWIRL knob to select between the first 3 channels or to match the MIDI channel of an incoming MIDI message.

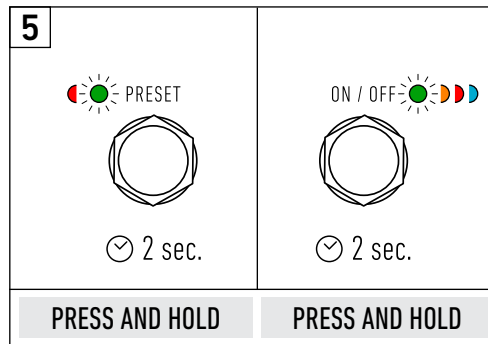

PRESS AND HOLD

PRESS AND HOLD

Press and hold both footswitches to confirm. Both Leds start blinking in the color corresponding to the channel selection.

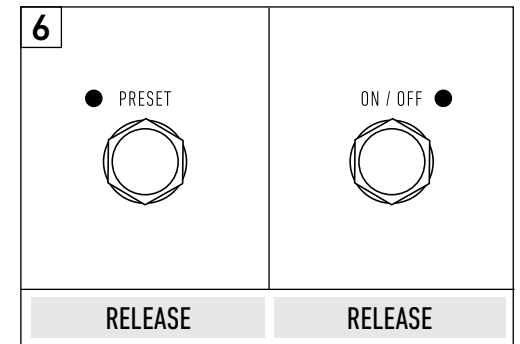

RELEASE

RELEASE

Release both footswitches. **Setting is over.** Repeat operation to change again.

HOW TO CONFIGURE THE MIDI OUTPUT CONNECTOR MODE : THRU/OUTPUT ?

Out of the box, the ELIPSE's MIDI OUT connector is set to function in MIDI THRU mode, meaning the pedal will send out the exact same MIDI messages it receives through the MIDI IN input. This enables you to daisy-chain multiple units via MIDI.

However, the ELIPSE can also output MIDI control messages by sending the actual values of each knob via MIDI to control other devices or to record knob movements in a DAW.

This can be enabled with MIDI OUT mode.

With the ELIPSE, you can choose between the following two modes :

MIDI THRU : All MIDI messages received on the MIDI IN connector are sent unmodified in real time to the MIDI OUT connector. The ELIPSE knobs don't send any MIDI messages.

MIDI OUT : Each knob movement will send the corresponding MIDI message to the MIDI OUT connector but MIDI messages received on the MIDI IN connector are not sent out.

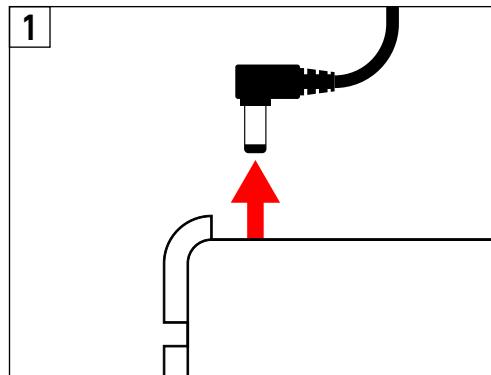

Unplug the power supply connector.

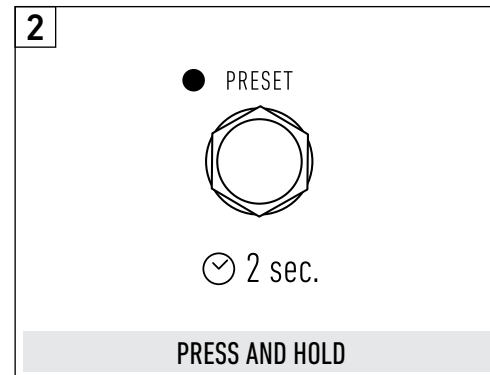

PRESS AND HOLD

Press and hold the PRESET footswitch while replugging the power supply connector

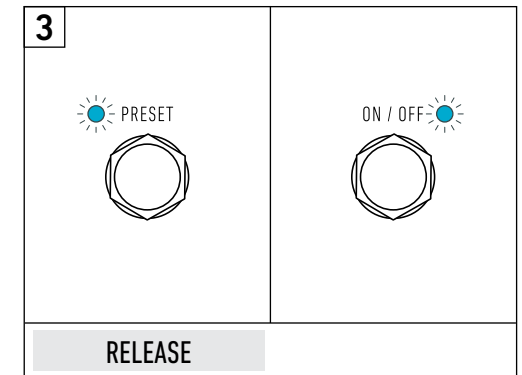

RELEASE

Both Leds start blinking blue. Release PRESET footswitch.

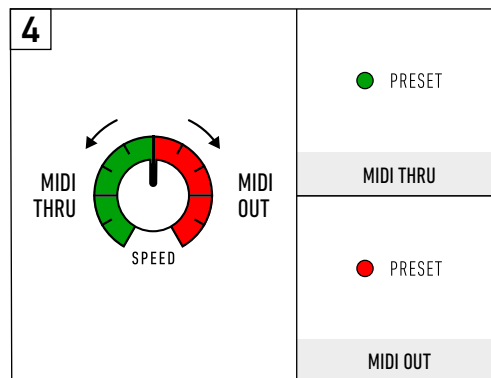

Turn the SPEED knob to select between MIDI THRU or MIDI OUT.

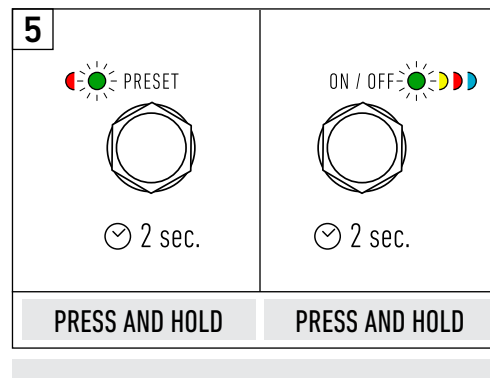

PRESS AND HOLD

PRESS AND HOLD

Press and hold both footswitches to confirm. Both Leds start blinking in the selected color (either green or red).

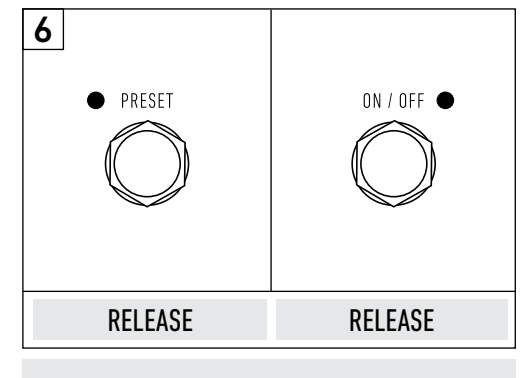

RELEASE

RELEASE

Release both footswitches. **Setting is over.** Repeat operation to change again.

HOW TO SAVE A MIDI PRESET ?

In the ELIPSE, there are 128 presets that can be accessed via MIDI. Each preset is linked to a MIDI program change message, with values ranging from 0 to 127.

For example, preset 1 is accessed through MIDI program change 1, preset 2 is accessed through MIDI program change 2 and so on.

Follow the next steps to save the knobs settings value to one of the MIDI preset slot and then recall it.



Note : Be aware that some devices or software recall presets with labeling from 0 to 127, while others use labeling from 1 to 128, even though technically they send MIDI PC messages that are always from 0 to 127. In both cases, the smallest number (0 or 1) is respectively used for the internal favorite preset.

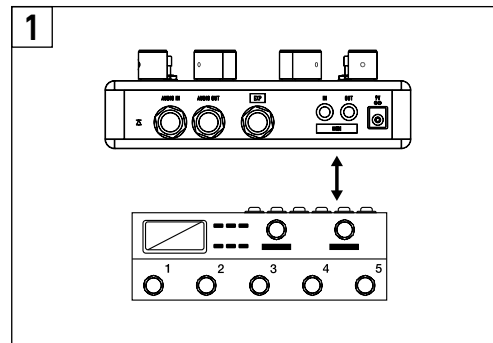

Connect the ELIPSE to an external device able to send MIDI Program Change messages via the ELIPSE's MIDI Input.

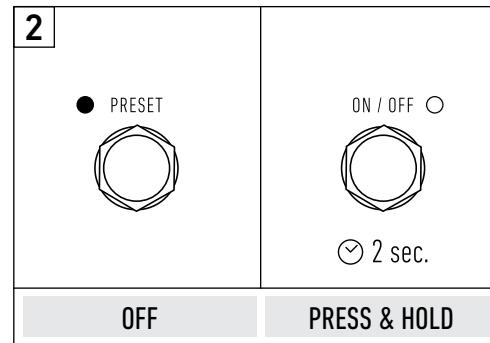

Make sure you are NOT in Preset mode, with the PRESET Led off. Press and hold the ON/OFF footswitch.

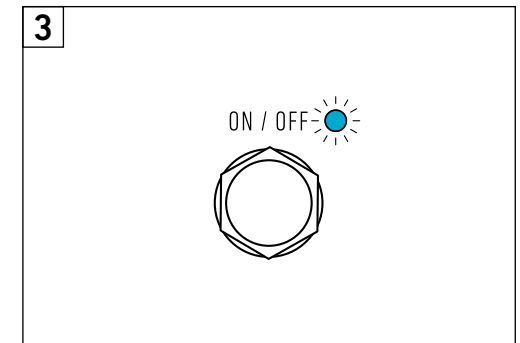

The ON/OFF Led starts slowly blinking blue, awaiting for an external MIDI Program Change message.

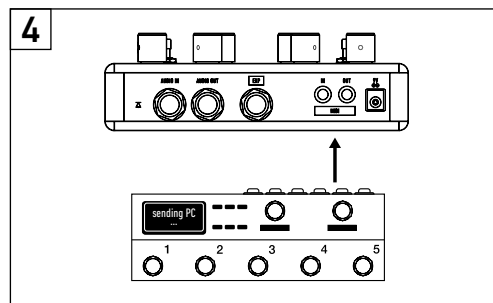

Send out the desired MIDI Program Change (PC 0 to 127) from your external device while making sure you are using the right MIDI channel. (see page 21)

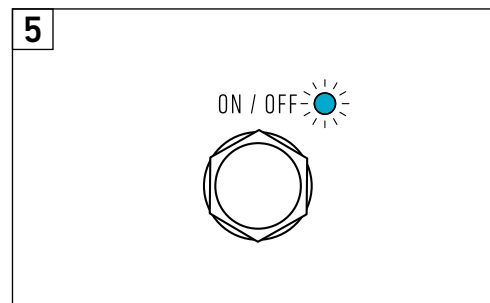

The ON/OFF Led starts quickly blinking blue to confirm the reception of the message and the saving procedure. The pedal returns to its previous state.

Tip : If you enter the procedure, being in step 3 but you want to escape the procedure without saving the preset, just press and hold the ON/OFF footswitch without sending any MIDI message. The pedal returns to its previous state.

Tip : The internal "favorite" preset is accessible thru MIDI program change n° 0. This preset can also be accessed directly using the procedure outlined on page 14.

HOW TO RECALL A MIDI PRESET ?

To recall and hear a specific MIDI preset, the user simply sends out a Program Change message to the ELIPSE from their external device, automatically turning the pedal on and recalling the desired preset (PC 0 to 127).

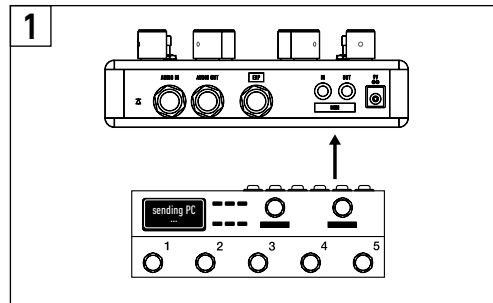

1 Send out the desired MIDI Program Change (PC 0 to 127) from your external device while making sure you are using the right MIDI channel. (see page 21)

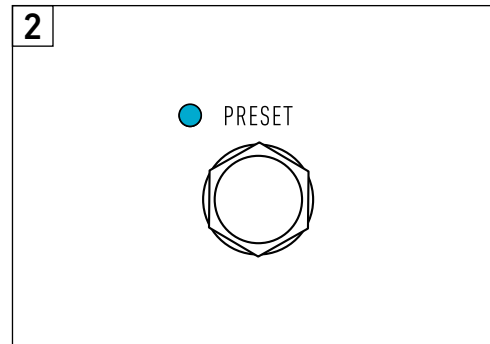

2 The PRESET Led turn blue to confirm the reception of the message and the loading of the preset.



Note : Programme Change number 0 is assigned to the internal favorite preset. In case you've send the PC 0, the PRESET led will turn white and not blue.



We have designed and included 10 specific presets in the ELIPSE to showcase the wide range of tones this pedal can achieve.

These presets can be instantly recalled via MIDI Program Changes (1 to 10).

Saving your own presets to slots 1-10 will overwrite these internal presets.

PC1 — Harmonic Tremolo

PC2 — Full Tremolo

PC3 — Fast Rotary

PC4 — Classic Analog Chorus

PC5 — Wide Tri Chorus

PC6 — Jet Flanger

PC7 — 90 Degrees Phaser

PC8 — 60's Vibe

PC9 — Phaser Madness

PC10 — Full Vibrato

HOW TO MODIFY A MIDI PRESET AND SAVE THE MODIFICATION INTO THE SAME PRESET ?

You may want to recall one of the MIDI preset, and modify one or more of the settings.

For example you want to keep the global tone of the preset, but only adjust the speed knob value to match a different song.

For that, just follow the next steps :

 **Tip :** If you only want to know the knobs position of one preset, without modifying them, follow the procedure turning the knob really slowly, and stop turning as soon the purple Led stop to blink and remain solid on.

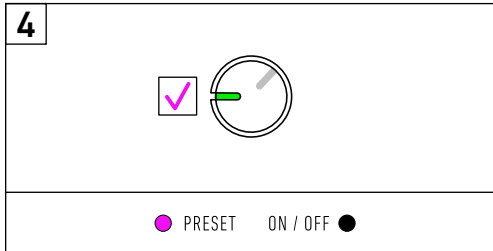

Once the saved position of the knob has been reached, the Leds stop blinking and the PRESET Led stays purple, indicating the user is in a modified version of the preset. The knob is now active again and can be dialed in to a new preferred setting.

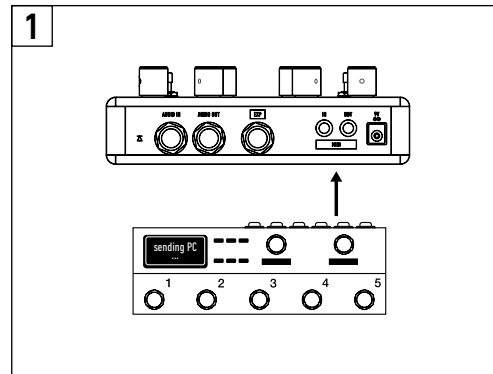

1 Recall a MIDI preset by sending the desired MIDI PC via your MIDI controller.

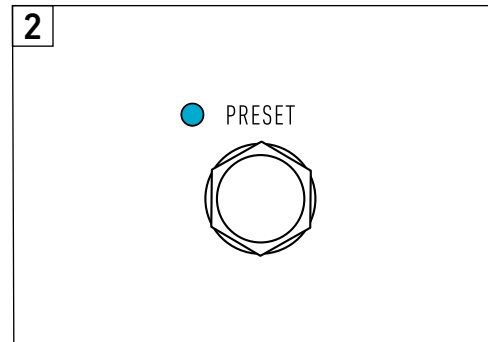

2 The PRESET Led turn blue to confirm the reception of the message and the loading of the preset.

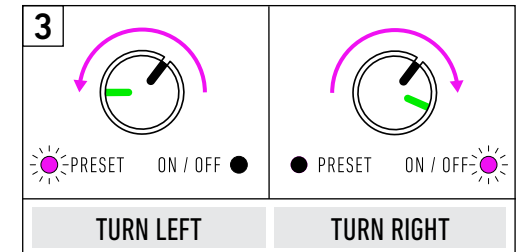

3 Move the knob you wish to modify. There will be no sound modification until you reach the saved value. **The Leds will help you:** Turn left if the PRESET Led blink purple or turn right if the ON/OFF Led blink purple.

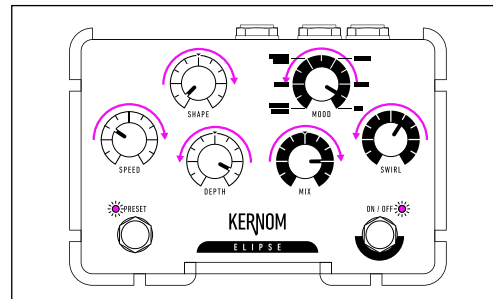

Repeat steps 2 and 3 on as many knobs as you like. If the user repeats the steps on all 6 knobs, the pedal leaves the preset as all knobs are now active.

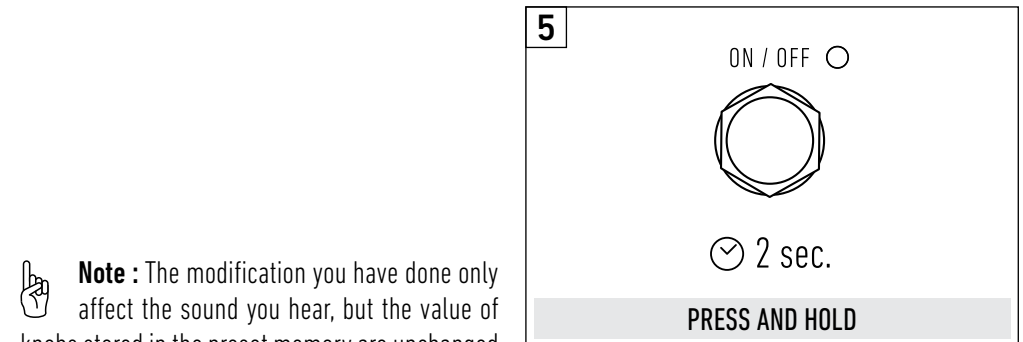

 **Note :** The modification you have done only affect the sound you hear, but the value of knobs stored in the preset memory are unchanged at that time.

If you want to save the modification into the preset memory, just follow the next step :

Once you are happy with the sound, press and hold the ON/OFF footswitch to save the new setting into the same slot.

HOW SAVE ONE MIDI PRESET INTO THE INTERNAL FAVORITE PRESET ?

You may want to recall one of the MIDI preset and store the knobs values into the internal favorite preset slot, for example if you only need 1 preset and won't have a MIDI devices for a specific gig.

Follow the next steps to save the knobs settings value of one MIDI preset into the internal favorite preset.

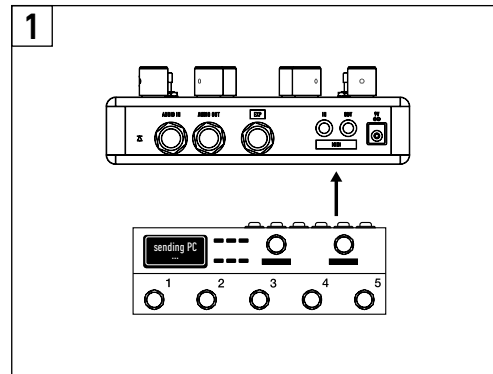

Recall a MIDI preset by sending the desired MIDI PC via your MIDI controller.

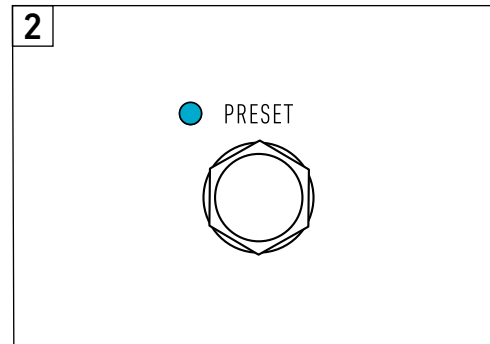

The PRESET Led turn blue to confirm the reception of the message and the loading of the preset.

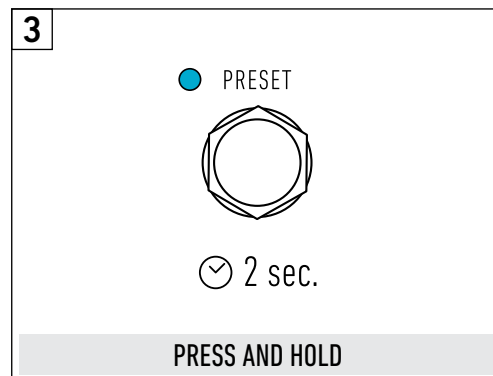

Press and hold the PRESET footswitch to save the new setting into the favorite preset slot*.

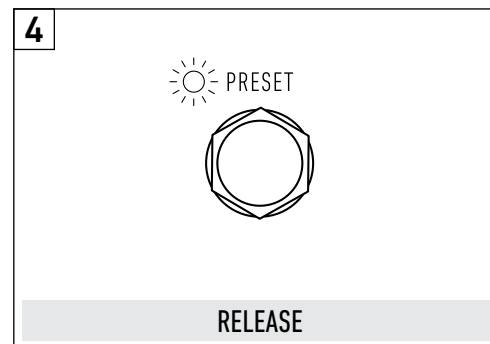

PRESET Led start blinking white to confirm. Release the PRESET footswitch. **Preset saved.**



***Note :** When a MIDI PC is received, the PRESET Led should become blue.



Tip : If you want to modify some values of the MIDI preset before saving to the internal favorite preset, just follow the procedure on the page 27.

HOW TO MODIFY A MIDI PRESET AND SAVE THE MODIFICATION INTO THE FAVORITE PRESET ?

For recalling one of the MIDI preset, modify some of the knobs values, and then save the modification into the internal favorite preset.

follow the next steps :

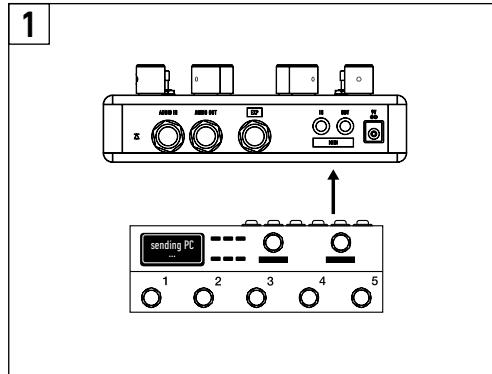

1 Recall a MIDI preset by sending the desired MIDI PC via your MIDI controller.

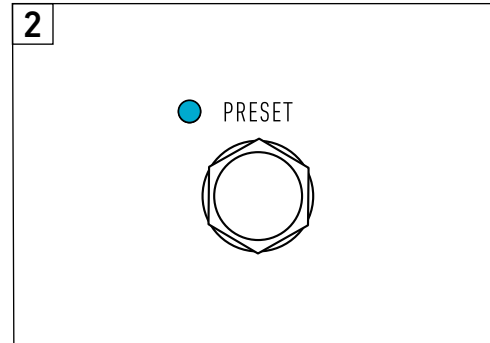

2 The PRESET Led turn blue to confirm the reception of the message and the loading of the preset.

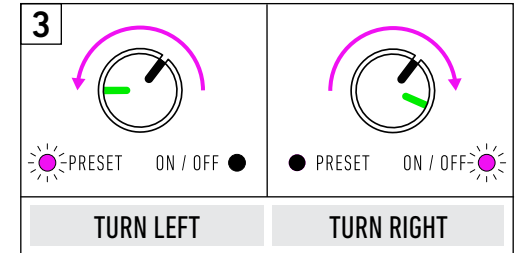

3 Move the knob you wish to modify. There will be no sound modification until you reach the saved value. **The Leds will help you:** Turn left if the PRESET Led blink purple or turn right if the ON/OFF Led blink purple.

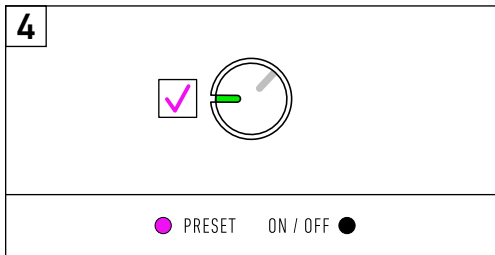

4 Once the saved position of the knob has been reached, the Leds stop blinking and the Preset Led stays purple, indicating the user is in a modified version of the preset. The knob is now active again and can be dialed in to a new preferred setting.

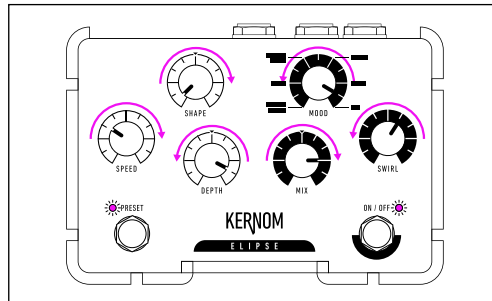

Repeat steps 2 and 3 on as many knobs as you like. If the user repeats the steps on all 6 knobs, the pedal leaves the preset as all knobs are now active.

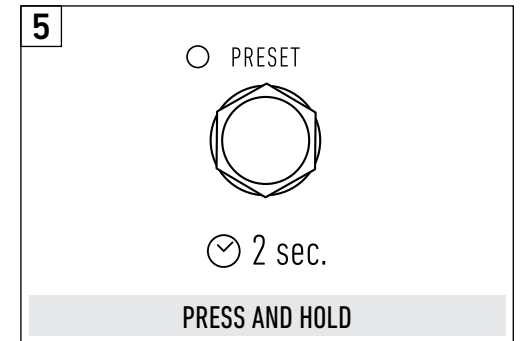

Note : The modification you have done only affect the sound you hear, but the value of knobs stored in the preset memory are unchanged at that time.

If you want to save the modification into the internal favorite preset memory, just follow the next step :

5 Once you are happy with the sound, press and hold the PRESET footswitch to save the new setting into the same slot.

HOW TO SAVE A MIDI PRESET INTO ANOTHER MIDI PRESET ?

You may want to save one preset values into another preset slots.

Follow the next procedure, making sure you are using the right MIDI channel (see page 21) :

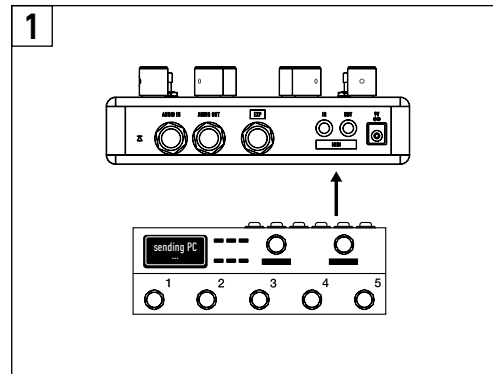

1 Recall a MIDI preset by sending the desired MIDI PC via your MIDI controller.

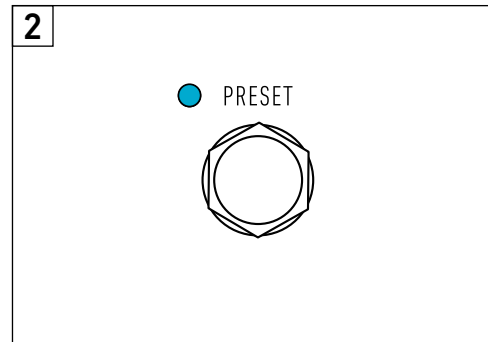

2 The PRESET Led turn blue to confirm the reception of the message and the loading of the preset.

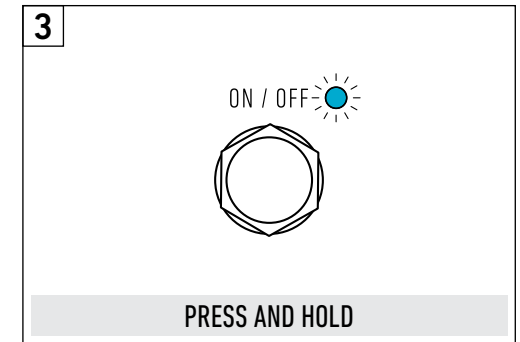

3 Press and hold the ON/OFF footswitch to enter the waiting mode for a MIDI PC message. The Led start blinking blue.

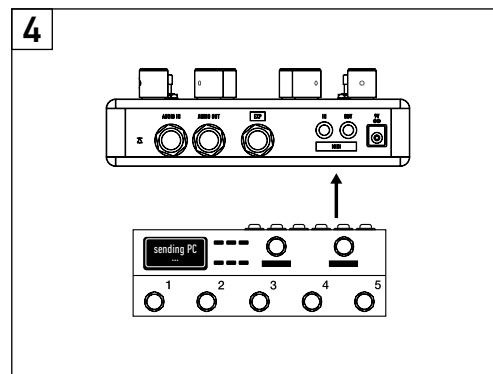

4 Send out the desired MIDI Program Change from your external device.

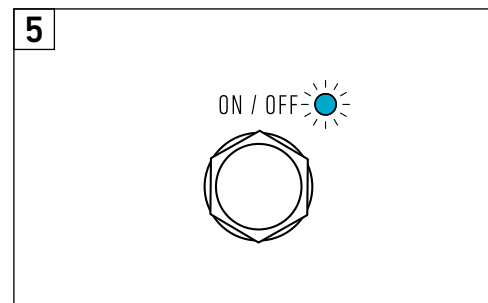

5 The ON/OFF Led starts quickly blinking blue to confirm the reception of the message and the saving procedure.
The pedal returns to its previous state.

Note : You cannot modify a MIDI preset and save the changes directly to another MIDI preset slot. To do this, first save the preset to modify to the target slot, then make your changes and save it again following the procedure on page 25.

HOW SAVE THE INTERNAL PRESET INTO ONE OF THE MIDI PRESET ?

You may want to save the internal favorite preset into one of the MIDI preset slots.

Follow the next steps to save the internal favorite preset values into one of the MIDI preset slots :

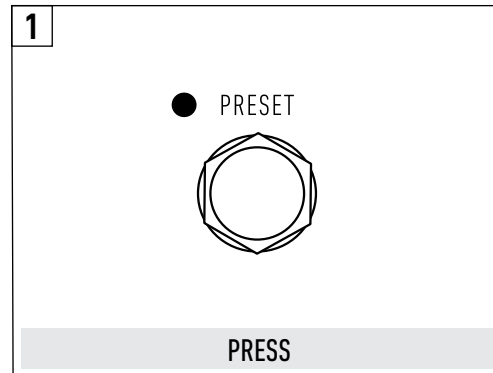

Press on the PRESET footswitch to recall your internal favorite preset.

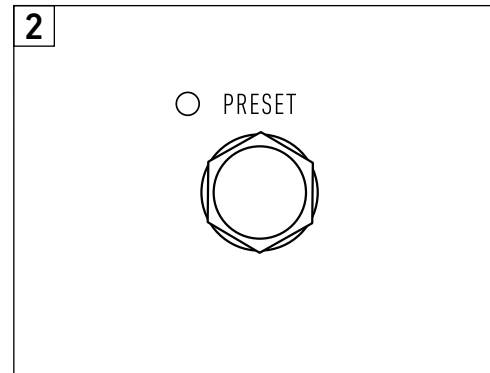

The PRESET Led should be white.

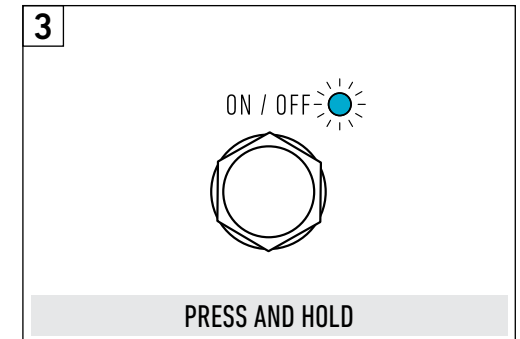

Press and hold the ON/OFF footswitch to enter the waiting mode for a MIDI PC message. The Led start blinking blue.

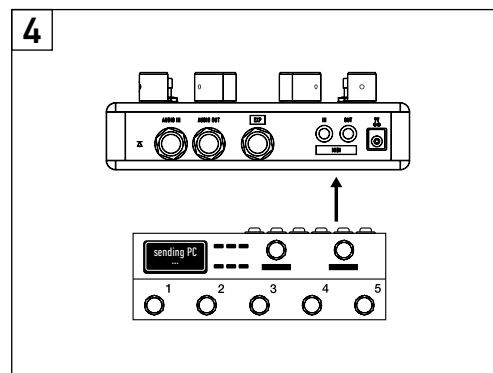

Send out the desired MIDI Program Change from your external device.

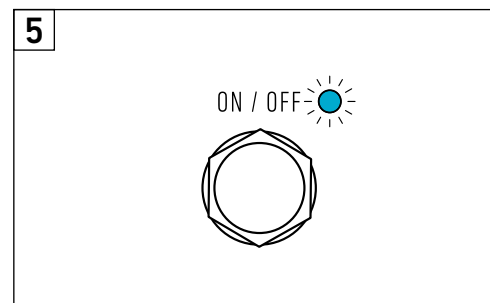

The ON/OFF Led starts quickly blinking blue to confirm the reception of the message and the saving procedure.
The pedal returns to its previous state.

HOW TO USE THE EXPRESSION PEDAL USING A MIDI PRESET ?

By default, when recalling a preset via MIDI and using an expression pedal, you can morph between the current positions of the knobs in the HEEL position and the MIDI preset settings in the TOE position.

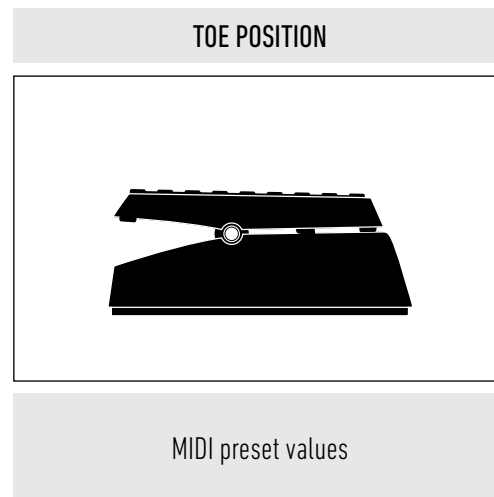
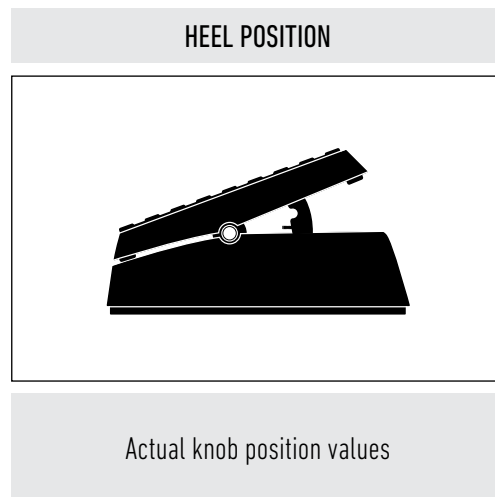

But, for each MIDI preset you have in fact the possibility to save different settings for the HEEL and TOE positions, effectively creating two sub-presets for every preset.

The following steps (1 to 4) outline the complete procedure for setting and saving the toe and heel positions for a MIDI preset.

STEP 1 ENTER THE PROCEDURE

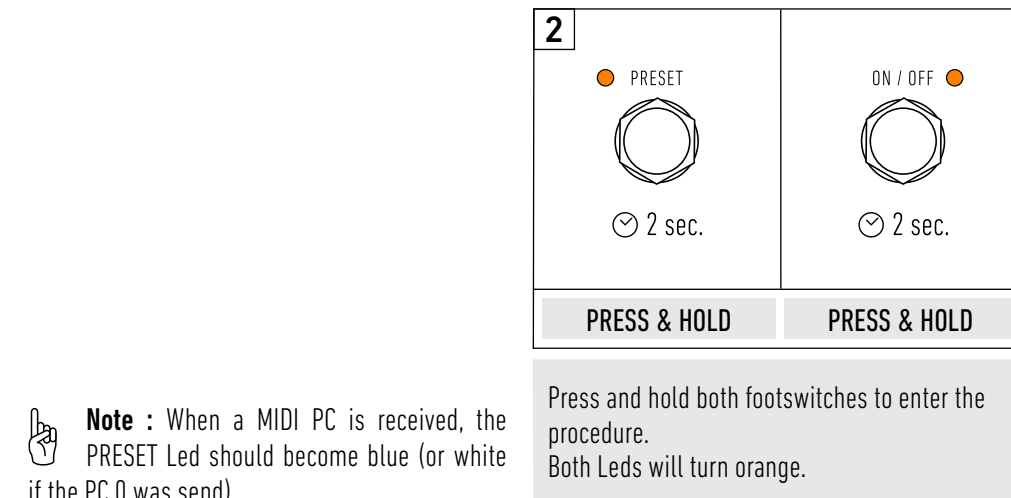
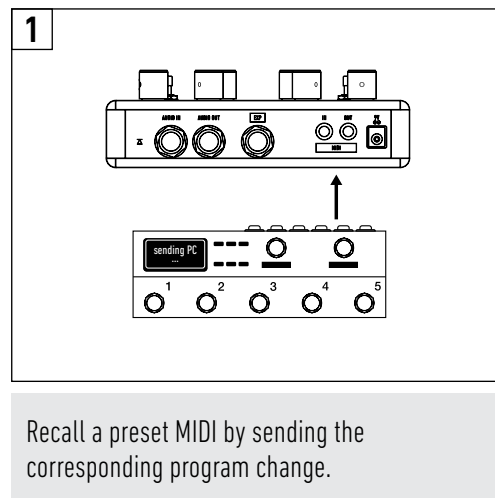

Note : When a MIDI PC is received, the PRESET Led should become blue (or white if the PC 0 was send).

HOW TO USE THE EXPRESSION PEDAL USING A MIDI PRESET ?

STEP 2

MODIFY THE HEEL POSITION

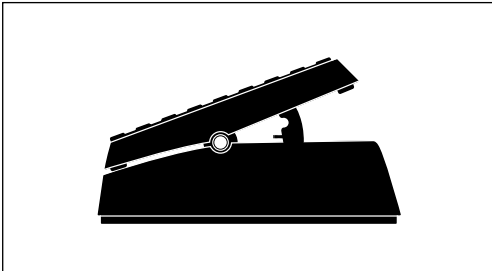

HEEL

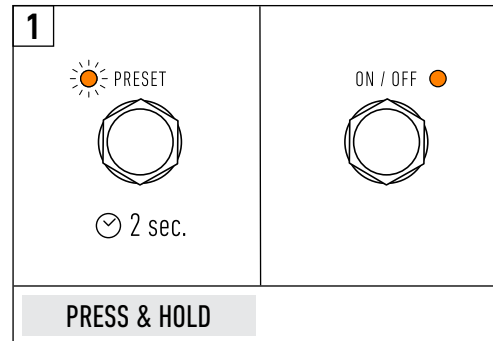

Press and hold the PRESET footswitch.
The PRESET Led starts to slowly blink while the ON/OFF Led remains lighted up in orange.

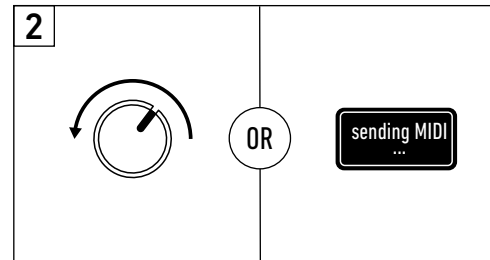

Either dial in your preferred toe position setting by turning the knobs, or send a PC message from an external controller to copy a specific preset and set it as the heel position of the preset you are creating

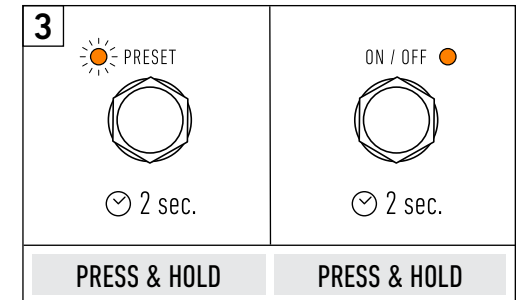

Press and hold both footswitches to save the heel position value.
The PRESET Led will blink quickly for 2 seconds to confirm, then both Leds will remain orange.

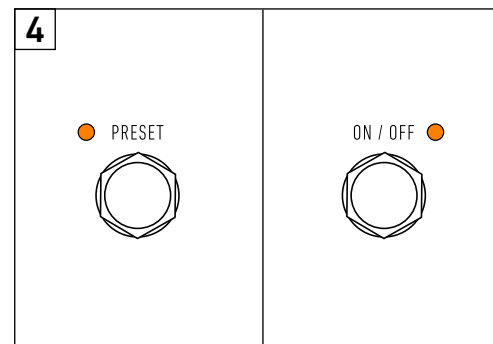

The PRESET Led stops blinking and both Leds are lighted up orange.
Heel position has been set.

 **Note :** If you would like to exit the HEEL modification without saving it just press and hold the PRESET footswitch.

HOW TO USE THE EXPRESSION PEDAL USING A MIDI PRESET ?

STEP 3 MODIFY THE TOE POSITION

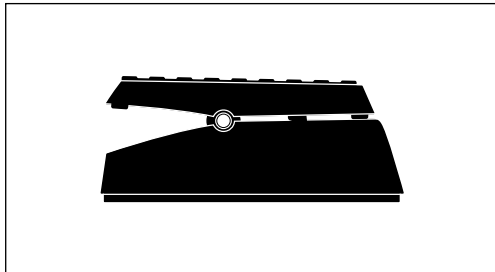

TOE

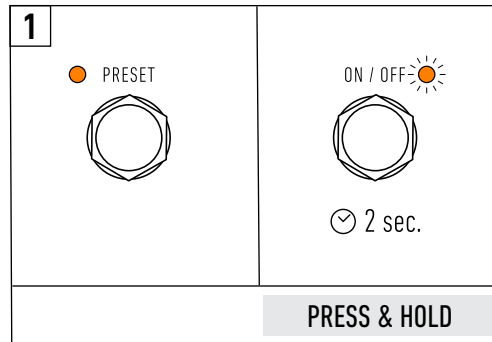

Press and hold the ON/OFF footswitch. The ON/OFF Led starts to slowly blink while the PRESET Led remains lighted up in orange.

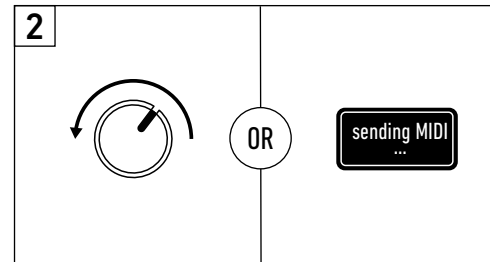

Either dial in your preferred toe position setting by turning the knobs, or send a PC message from an external controller to copy a specific preset and set it as the toe position of the preset you are creating.

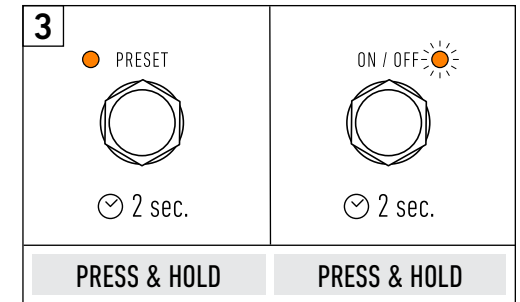

Press and hold both footswitches to save the toe position value. The ON/OFF Led will blink quickly for 2 seconds to confirm, then both Leds will remain orange.

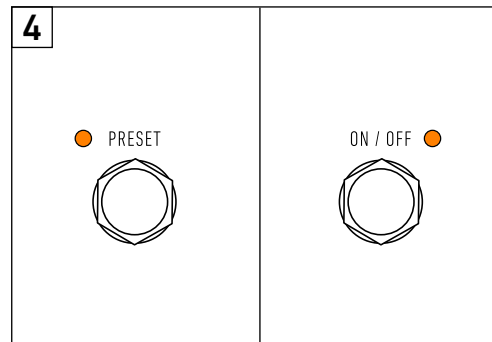

The PRESET Led stops blinking and both Leds are lighted up orange.
Toe position has been set.

Note : If you would like to exit the TOE modification without saving it just press and hold the PRESET footswitch.

HOW TO USE THE EXPRESSION PEDAL USING A MIDI PRESET ?

STEP 4

VALIDATE AND EXIT THE PROCEDURE

To exit the global position setting mode and go back to the previously active state of the pedal, just follow the next procedure :



Note : You can repeat steps 2 and 3 as many times as needed before exiting the procedure.

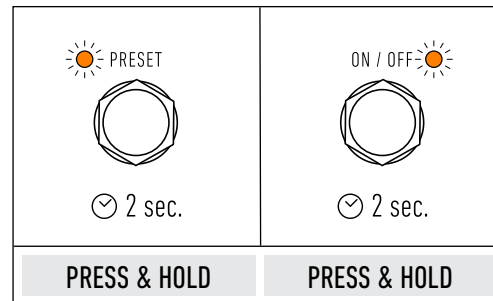

Both Leds will blink quickly for 2 seconds to confirm.
Then Leds come back to the configuration they were in before the procedure was initiated.

MIDI presets for which you do not follow the described procedure will retain the default behavior with expression pedal (current knob values at the heel position).

HEEL POSITION

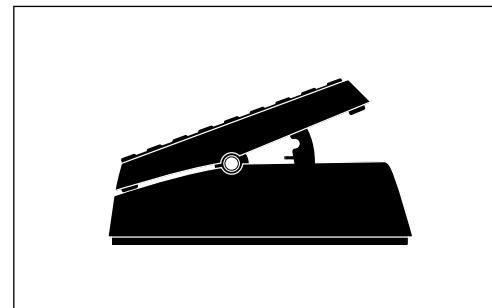

MIDI preset HEEL position value

TOE POSITION

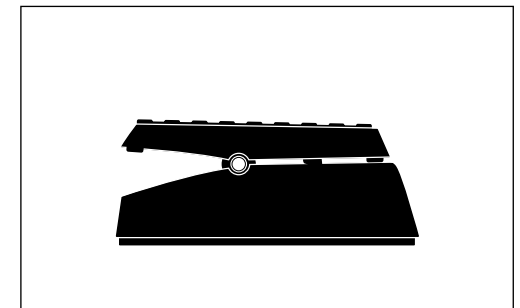

MIDI preset TOE position value

Here is how the expression pedal will behave for the MIDI preset slot you configured by completing steps 1 to 4 of the procedure :

HOW TO USE MIDI CONTROL CHANGE MESSAGES WITH THE ELIPSE ?

MIDI CONTROL CHANGE MESSAGES ARE USED TO REMOTELY MODIFY THE PARAMETERS OF ONE SOUND DEVICES FROM ANOTHER CONTROL DEVICES.

In the case of the ELIPSE, it allows you to control the parameters of the ELIPSE from another MIDI device like a MIDI switcher, or from a DAW inside a computer. It can also be used to receive Tap tempo, and set the tempo subdivisions.

The ELIPSE parameters can all be controlled remotely receiving MIDI CC, or also you can control another MIDI device by moving the knobs of the ELIPSE.

MIDI CC number	ELIPSE parameter	min value	max value
CC 20	SHAPE	1	127
CC 21	MOOD	1	127
CC 22	SPEED	1	127
CC 23	DEPTH	1	127
CC 24	MIX	1	127
CC 25	SWIRL	1	127
CC 26	EXP	1	127
CC 27	FS preset		
CC 28	FS ON/OFF		
CC 85	TAP TEMPO		
CC 86	TEMPO SUBDIVISION		

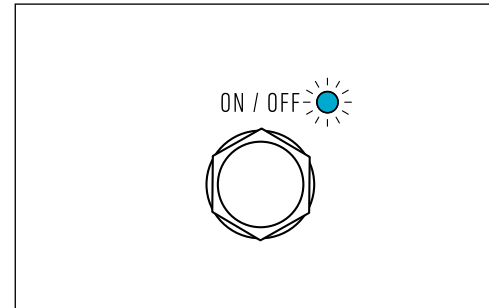

When a MIDI Control Changes (CC) is sent to the ELIPSE, the ON/OFF LED turns blue to indicate the pedal is currently using its MIDI functionalities.

The ELIPSE is also able to send out MIDI Control Changes (CC) through its MIDI output, to control an external device.

When doing so, the value of the Control Change (CC) message being sent out is always that of the current position of each potentiometer.

 **Tip :** ELIPSE parameters values are modified when receiving the associated MIDI value. If you move then again the knobs, the parameters jump again to the actual position of the knobs.

 **Tip :** ELIPSE can outputs the knobs position values as MIDI CC messages. For enabling that, follow the procedure on the page 22 to set the ELIPSE on MIDI output mode.

HOW TO USE AN EXTERNAL MIDI FOOTSWITCH AS A TAP TEMPO ?

The tap tempo feature allows you to sync the modulation speed of an effect (like delay, chorus, or tremolo) to the song's rhythm by tapping the tempo on a footswitch.

This provides real-time flexibility to match the groove of a performance.

Thanks to the MIDI input on the ELIPSE, you can use the footswitch of a MIDI switcher to control the tap tempo for the modulation effect by assigning MIDI Control Change 85 to the desired footswitch. This allows you to synchronize the speed of the main effect's LFO to the tempo set by foot.

To use this feature, follow step 1 to 3 :

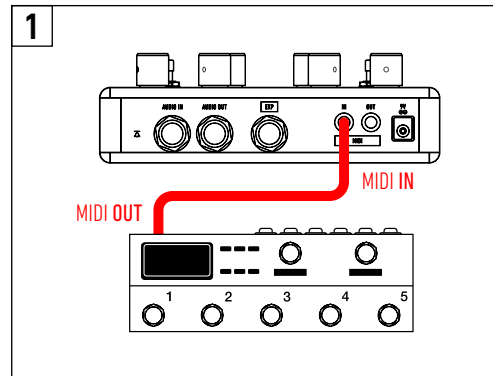

Connect a MIDI switcher with an assignable footswitch to the MIDI input of the ELIPSE.

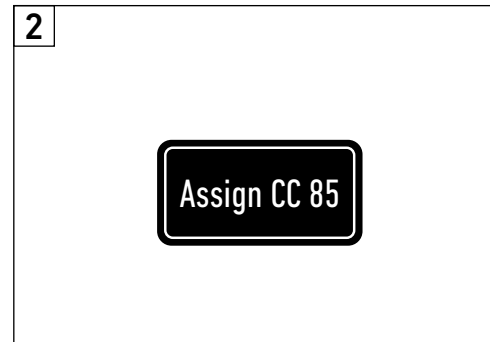

Assign MIDI Control Change (CC) 85 to the footswitch you want to use on your MIDI switcher.

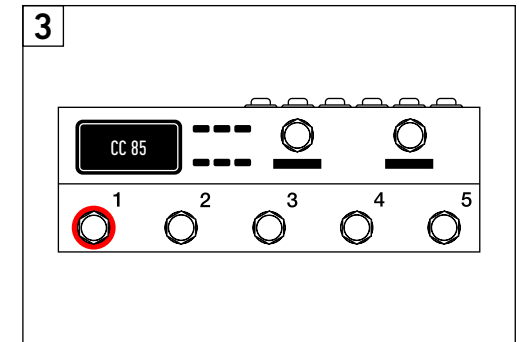

When tapping this footswitch two or more times in rhythm, the ELIPSE's LFO will automatically sync to the tempo.

 **Tip :** When the LFO speed is set by tapping the tempo on the MIDI switcher, it becomes decorrelated from the current position of the Speed knob. However, adjusting the Speed knob at any time will instantly update the LFO speed to match the knob's position.

 **Note :** If tap tempo features does not react, please follow the procedure on next page to check if the ELIPSE might be in MIDI clock sync settings.

HOW TO USE MIDI CLOCK ?

The MIDI clock is a timing signal used to synchronize multiple MIDI devices, ensuring they all follow the same tempo.

It is a standard feature of the MIDI protocol, allowing devices to communicate and stay in sync with each other. The ELIPSE is equipped with MIDI clock functionality and can be synchronized to a MIDI clock master device.

To enable this feature, follow the procedure to set the Elipse to MIDI clock mode.

Please note that for ease of use, you cannot have both tap tempo and MIDI clock enabled at the same time.

When the ELIPSE is set to tap tempo mode, MIDI clock message are ignored.

When ELIPSE is set to MIDI clock mode, MIDI tap tempo message are ignored.



Note : By default, the ELIPSE is set to tap tempo mode. At any time if you want to go back to tap tempo mode, follow the same procedure. On step 4, turn the SWIRL knob to min (the ON/OFF led turn green) to set the ELIPSE back to tap tempo mode.

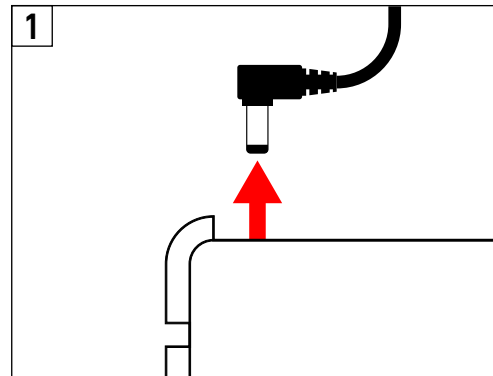

Unplug the power supply connector.

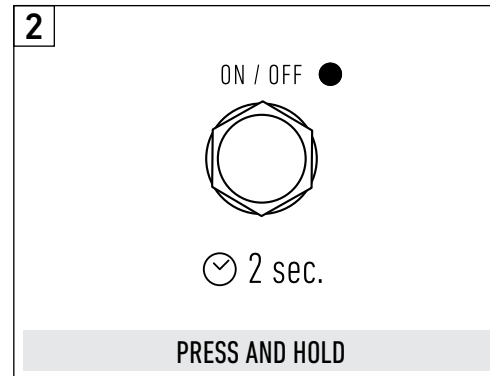

PRESS AND HOLD

Press and hold the ON/OFF footswitch.

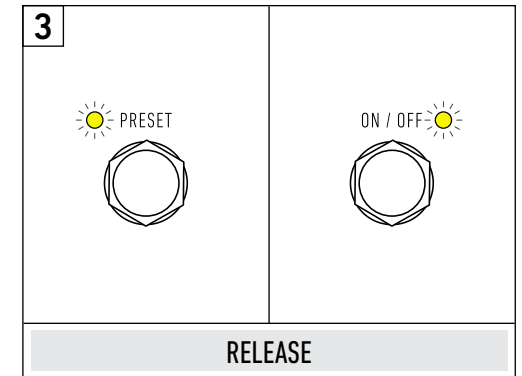

RELEASE

Led switching in red, release the footswitch.

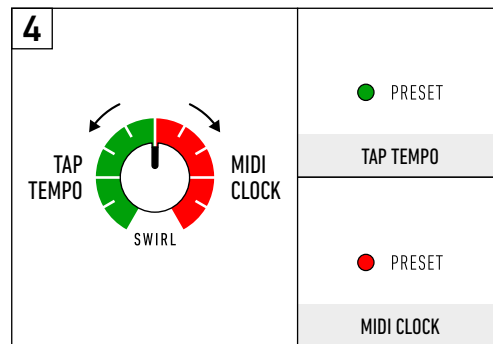

PRESET

TAP TEMPO

PRESET

MIDI CLOCK

The SWIRL knob now control the sync mode of the ELIPSE. Turn it to the max enable the MIDI clock syncro mode (ON/OFF Led turn red)

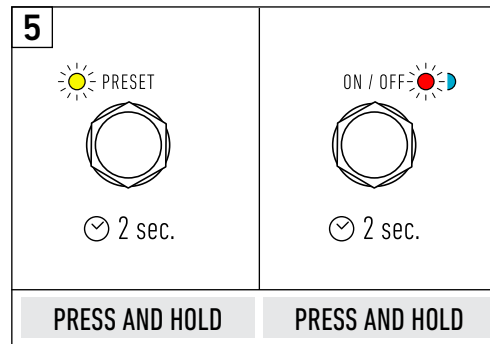

PRESS AND HOLD

PRESS AND HOLD

Press and hold both footswitches to confirm.
Both Leds start blinking.

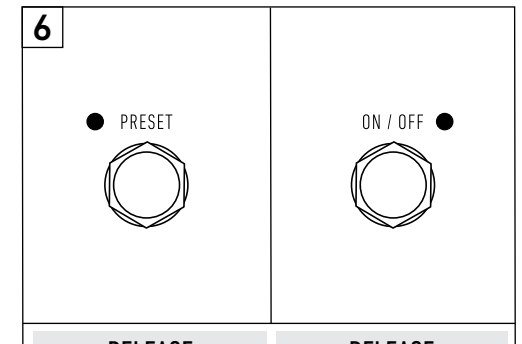

RELEASE

RELEASE

Release both footswitches.
Setting is over.

HOW TO USE MIDI TEMPO SUBDIVISION ?

A TEMPO SUBDIVISION IS WHEN YOU DIVIDE A BEAT INTO SMALLER PARTS, LIKE SPLITTING A QUARTER NOTE INTO TWO EIGHTH NOTES OR FOUR SIXTEENTH NOTES.

This is useful because it helps you match effects more precisely to the music's rhythm. If the speed of the ELIPSE is set to match a particular tempo (might be by manual speed knob, midi tap tempo, or midi clock, you can choose to modify the subdivision associated with this tempo

In the ELIPSE, subdivision value are set using a MIDI CC message number 86.

The following chart give you the value of CC 86 to send for each subdivision available inside the ELIPSE.

MIDI CC86 Value	Speed subdivision value	Name
10	1 : 4	whole note
20	1 : 2	half note
30	2 : 3	dotted quarter
50	1 : 1	quarter note
60	4 : 3	dotted eight
70	3 : 2	quarter triplets
90	2 : 1	8th note
100	3 : 1	8th triplets
110	4 : 1	16th note
120	6 : 1	16th triplets

 **Note :** Please note that the subdivision state value is not saved when saving the internal favorite preset or a MIDI preset.

Additionally, the subdivision state will remain at the last received value until a new one is received, even if the power supply is unplugged and reconnected. To reset the pedal to its standard speed range setting, send MIDI CC number 86 with a value of 50.

 **Tip :** By using subdivisions higher than 1:1, like eight notes, you can achieve faster LFO speeds than those available directly with the SPEED knob. This can lead to fun, experimental results, especially when setting the SPEED knob to maximum and selecting a high subdivision.

E L I P S E

TECHNICAL SPECIFICATIONS

TECHNICAL SPECIFICATIONS

FEATURES

Multi modulation effect - ANALOG MOPRING CORE patented technology

Effects : Tremolo, Harmonic tremolo, Rotary, Chorus, Vibrato, Flanger, Phaser, Vibe

Premium input stage and Ultra low noise output

True Bypass with relay switching

Expression pedal input

MIDI In/Out

1 Internal favorite preset

127 MIDI presets

5mm thick touring ready casing

SPECIFICATIONS

INPUT IMPEDANCE : 1Meg Ohm

OUTPUT IMPEDANCE : 100 Ohm

AD AND DA CONVERSIONS : 24 bits, 48 kHz

DIMENSIONS : 11.2 cm deep x 16.4 cm wide x 5.2 cm tall (4.4 inches deep x 6.5 inches wide x 2 inches tall).

WEIGHT : 850 g (1,8 lbs)

POWER ADAPTER REQUIREMENTS

Use an adaptor (not included) with the following rating: 9VDC center negative, 150mA minimum, 200mA or more recommended.

MIDI REQUIREMENTS

Use only type A midi to trs cable to connect the ELISPE to a midi switcher or any MIDI devices, to save and recall up to 128 preset, ad tap tempo and mici clock features, and time division variation (more on page 19).



WARRANTY

Kernom warrants the product to be free from defects in material and workmanship for a period of two (2) years from the original date of purchase when bought new from an authorized dealer in the United States of America and can be extended to (3) years after registering on Kernom's website. If the product fails within the warranty period, Kernom will repair or, at our discretion, replace the product at no cost to the original purchaser. Please contact your dealer for information on warranty and service outside of the USA.

EXCLUSIONS

This warranty covers defects in manufacturing discovered while using this product as recommended by Kernom. This warranty does not cover loss or theft, nor does the coverage extend to damage caused by misuse, abuse, unauthorized modification, improper storage, lightning, or natural disasters.

LIMITS OF LIABILITY

In the case of malfunction, the purchaser's sole recourse shall be repair or replacement, as described in the preceding paragraphs. Kernom will not be held liable to any party for damages that result from the failure of this product. Damages excluded include, but are not limited to, the following: lost profits, lost savings, damage to other equipment, and incidental or consequential damages arising from the use, or inability to use this product. In no event will Kernom be liable for more than the amount of the purchase price, not to exceed the current retail price of the product. Kernom disclaims any other warranties, expressed or implied. By using the product, the user accepts all terms herein.

HOW TO OBTAIN SERVICE UNDER THIS WARRANTY

For North American customers: Contact Algam USA through their website at www.algam.net for Return Authorization and information. Proof of original ownership may be required in the form of a purchase receipt.

For International Customers : Contact the Kernom dealer from which the product was purchased from in order to arrange warranty repair service.

SAFETY AND COMPLIANCE INFORMATION

This equipment has been tested and found to comply with the limits for a class B digital device, pursuant to part 15 of the FCC Rules.

These limits are designed to provide reasonable protection against harmful interference in a residential installation. This equipment generates, uses, and can radiate radio frequency energy and if not installed and used in accordance with the instructions, may cause harmful interference to radio communications. However, there is no guarantee that interference will not occur in a particular installation. If this equipment does cause harmful interference to radio or television reception, which can be determined by turning the equipment off and on, the user is encouraged to try to correct the interference by one or more of the following measures:

- 1) Reorient or relocate the receiving antenna
- 2) Increase the separation between the equipment and receiver
- 3) Connect the equipment into an outlet on a circuit different from that to which the receiver is connected
- 4) Consult the dealer or an experienced radio/TV technician for help



This product is imported in the US by :

ALGAM USA Inc.
4981 Park Rd., 94510 BENICIA – USA
contact@algam.net – www.algam.net

KERNOM

41 WARRANTY
EU

WARRANTY

Kernom warrants the product to be free from defects in material and workmanship for a period of two (2) years from the original date of purchase when bought new from an authorized dealer in the European Union (liste de tous les pays d'europe dans lesquels ont est distribue) and can be extended to (3) years after registering on Kernom's website.

If the product fails within the warranty period, Kernom will repair or, at our discretion, replace the product at no cost to the original purchaser. Please contact your dealer for information on warranty and service outside of Europe.

EXCLUSIONS

This warranty covers defects in manufacturing discovered while using this product as recommended by Kernom. This warranty does not cover loss or theft, nor does the coverage extend to damage caused by misuse, abuse, unauthorized modification, improper storage, lightning, or natural disasters.

LIMITS OF LIABILITY

In the case of malfunction, the purchaser's sole recourse shall be repair or replacement, as described in the preceding paragraphs. Kernom will not be held liable to any party for damages that result from the failure of this product. Damages excluded include, but are not limited to, the following: lost profits, lost savings, damage to other equipment, and incidental or consequential damages arising from the use, or inability to use this product. In no event will Kernom be liable for more than the amount of the purchase price, not to exceed the current retail price of the product Kernom disclaims any other warranties, expressed or implied. By using the product, the user accepts all terms herein.

HOW TO OBTAIN SERVICE UNDER THIS WARRANTY

For European customers: Contact Algam through their website at www.algam.net for Return Authorization and information. Proof of original ownership may be required in the form of a purchase receipt.

For International Customers : Contact the Kernom dealer from which the product was purchased from in order to arrange warranty repair service.

SAFETY AND COMPLIANCE INFORMATION

This equipment has been tested and found to comply with the essential requirements of the applicable CE directives. The full Declaration of Conformity is available upon request.

These limits are designed to provide reasonable protection against harmful interference in a residential installation.

This product also complies with the RoHS Directive, which restricts the use of hazardous substances in electrical and electronic equipment.

Lastly, this product must be disposed of in accordance with local regulations on the disposal of electrical and electronic equipment (WEEE).



This product is imported in the EU by :

ALGAM SAS

2 rue de Milan, 44470 THOUARE SUR LOIRE – FRANCE
contact@algam.net – www.algam.net

KERNOM

42 WARRANTY
JAPAN

WARRANTY

Kernom warranties the product to be free from defects in material and workmanship for a period of two (2) years from the original date of purchase when bought new from an authorized dealer in the European Union (liste de tous les pays d'europe dans lesquels ont est distribue) and can be extended to (3) years after registering on Kernom's website.

If the product fails within the warranty period, Kernom will repair or, at our discretion, replace the product at no cost to the original purchaser. Please contact your dealer for information on warranty and service outside of Europe.

EXCLUSIONS

This warranty covers defects in manufacturing discovered while using this product as recommended by Kernom. This warranty does not cover loss or theft, nor does the coverage extend to damage caused by misuse, abuse, unauthorized modification, improper storage, lightning, or natural disasters.

LIMITS OF LIABILITY

In the case of malfunction, the purchaser's sole recourse shall be repair or replacement, as described in the preceding paragraphs. Kernom will not be held liable to any party for damages that result from the failure of this product. Damages excluded include, but are not limited to, the following: lost profits, lost savings, damage to other equipment, and incidental or consequential damages arising from the use, or inability to use this product. In no event will Kernom be liable for more than the amount of the purchase price, not to exceed the current retail price of the product Kernom disclaims any other warranties, expressed or implied. By using the product, the user accepts all terms herein.

HOW TO OBTAIN SERVICE UNDER THIS WARRANTY

For European customers: Contact Algam through their website at <https://kyoritsu-group.com/en/> for Return Authorization and information. Proof of original ownership may be required in the form of a purchase receipt.

For International Customers : Contact the Kernom dealer from which the product was purchased from in order to arrange warranty repair service.

SAFETY AND COMPLIANCE INFORMATION

This equipment has been tested and found to comply with the essential requirements of the applicable CE directives. The full Declaration of Conformity is available upon request.

These limits are designed to provide reasonable protection against harmful interference in a residential installation.

This product also complies with the RoHS Directive, which restricts the use of hazardous substances in electrical and electronic equipment.

Lastly, this product must be disposed of in accordance with local regulations on the disposal of electrical and electronic equipment (WEEE).



This product is imported in Japan by :

KYORITSU CORPORATION, LTD.

Jyuichiya Minatoku 2 chome 247 Nagoya city, AICHI-KEN – JAPAN
<https://kyoritsu-group.com/en/>

KERNOM

43 WARRANTY
CHINA

WARRANTY

Kernom warranties the product to be free from defects in material and workmanship for a period of two (2) years from the original date of purchase when bought new from an authorized dealer in the European Union (liste de tous les pays d'europe dans lesquels ont est distribue) and can be extended to (3) years after registering on Kernom's website.

If the product fails within the warranty period, Kernom will repair or, at our discretion, replace the product at no cost to the original purchaser. Please contact your dealer for information on warranty and service outside of Europe.

EXCLUSIONS

This warranty covers defects in manufacturing discovered while using this product as recommended by Kernom. This warranty does not cover loss or theft, nor does the coverage extend to damage caused by misuse, abuse, unauthorized modification, improper storage, lightning, or natural disasters.

LIMITS OF LIABILITY

In the case of malfunction, the purchaser's sole recourse shall be repair or replacement, as described in the preceding paragraphs. Kernom will not be held liable to any party for damages that result from the failure of this product. Damages excluded include, but are not limited to, the following: lost profits, lost savings, damage to other equipment, and incidental or consequential damages arising from the use, or inability to use this product. In no event will Kernom be liable for more than the amount of the purchase price, not to exceed the current retail price of the product Kernom disclaims any other warranties, expressed or implied. By using the product, the user accepts all terms herein.

HOW TO OBTAIN SERVICE UNDER THIS WARRANTY

For European customers: Contact Algam through their website at marketing@tmsdistro.com for Return Authorization and information. Proof of original ownership may be required in the form of a purchase receipt.

For International Customers : Contact the Kernom dealer from which the product was purchased from in order to arrange warranty repair service.

SAFETY AND COMPLIANCE INFORMATION

This equipment has been tested and found to comply with the essential requirements of the applicable CE directives. The full Declaration of Conformity is available upon request.

These limits are designed to provide reasonable protection against harmful interference in a residential installation.

This product also complies with the RoHS Directive, which restricts the use of hazardous substances in electrical and electronic equipment.

Lastly, this product must be disposed of in accordance with local regulations on the disposal of electrical and electronic equipment (WEEE).



This product is imported in China by :

TMS

Foshan Tone Music Service Culture
Media Limited
Room406, 1 stairs of phase 1, poly canal
plaza, Denghu west Road, Guicheng,
Nanhai District
528000 Foshan City - China
marketing@tmsdistro.com
+86-13189606112